



# Railway Mechanical Engineer

---

Established 1832

---

## INDEX TO VOLUME XC 1916

5478

1  
2  
3  
4  
5  
6  
7  
8  
9  
10  
11  
12  
13  
14  
15  
16  
17  
18  
19  
20  
21  
22  
23  
24  
25  
26  
27  
28  
29  
30  
31  
32  
33  
34  
35  
36  
37  
38  
39  
40  
41  
42  
43  
44  
45  
46  
47  
48  
49  
50  
51  
52  
53  
54  
55  
56  
57  
58  
59  
60  
61  
62  
63  
64  
65  
66  
67  
68  
69  
70  
71  
72  
73  
74  
75  
76  
77  
78  
79  
80  
81  
82  
83  
84  
85  
86  
87  
88  
89  
90  
91  
92  
93  
94  
95  
96  
97  
98  
99  
100

ALSO OF THE

## DAILY RAILWAY AGE GAZETTE

ISSUED DURING THE

M. M. AND M. C. B. CONVENTIONS



# INDEX, 1916

## VOLUME XC

### A

Accounting, Storekeepers' convention.....	290
Acetylene, Corrosive effect of.....	174†
Acme Supply Company, Enclosed groove curtain fixtures.....	482°
Acme Supply Company, Folding tail gate..	324°
Adams, T. H., The operation of a large engine terminal.....	368
Address, The president's, M. M. Association	1444‡
Air brake apprentices, by C. M. Drennen, Air Brake convention.....	301
Air Brake Assn. (see Meetings).	
Air Brake Association convention.....	274‡
Air Brake Association convention report...	299°
Air Brake Association, Co-operation with the Air brake conditions, Car foreman's responsibility for, by Lawrence Wilcox.....	1423‡
134	
Air brake, Excess pressure, by M. S. Belk, Air Brake convention.....	304
Air brake hose, Metal, Dodge Metal Hose Company.....	1314°
Air brake maintenance.....	1395‡
Air brake maintenance, by John P. Kelly..	352
Air brake on French passenger equipment, combined automatic and straight, by W. G. Landon.....	442*‡
Air brake recommended practice, Air Brake convention.....	304
Air brakes and air signals, M. C. B. convention.....	1290°
Air compressor, Fuel oil driven, Chicago Pneumatic Tool Co.....	261°
Air compressors, Capacity regulation for, Chicago Pneumatic Tool Co.....	1468
Air pockets, Removing, from reservoirs, by W. H. Hauser.....	372°
Air pump bracket, adjustable, Union Pacific	631°
Air pump packing rings, Finishing, by F. R. Stewart.....	461°
Air pumps, Lubricator for.....	210°
Air reservoir support.....	628°
Air signal reducing valve stem, Drift for truing up, by F. W. Bentley, Jr.....	652°
Aisle strips, Depressed, Union Pacific.....	402°
Alexander, G. W., Material delivery at the Macon shops.....	359
American Locomotive Co., Woodard throttle	48°
American Mason Safety Tread Co., Safety tread with diamond grooving.....	1269°
American Railroad Master Tinner's, Copper-smiths' and Pipefitters' Assn. (see Meetings).	
American Railway Master Mechanics' Association (see Master Mechanics' Association).	
American Railway Master Mechanics' Association (see Meetings).	
American Railway Tool Foreman's Assn. (see Meetings).	
American Railway Tool Foremen's Assn. (see Tool Foremen's Association).	
American Society for Testing Materials (see Meetings).	
American Society of Mechanical Engineers (see Meetings).	
American Steel Foundries, Ajax third point support.....	156°
American Steel Foundries, Adjustable coupler pocket.....	1312°
Angle cocks, Repairing, by Howard W. Stall	309°
Anthony, J. T., Locomotive boiler efficiency.....	443°
505°	
Apprentice competition, The.....	57‡
Apprentice competition, The.....	165‡
Apprentice competition, Car department...	1280‡
Apprentice competition, Don't scold, by Arthur J. Merriman.....	255
Apprentice competition, first prize article, by J. C. Bowman.....	197
Apprentice competition, second prize article, by E. C. Crawford.....	197
Apprentice conference, Santa Fe.....	363°
Apprentice, Developing the.....	166‡
Apprentice, Four suggestions from an, by Carl J. Pryor.....	256
Apprentice, Help the, to help himself, by Frank J. Borer.....	92
Apprentice, How can I help the, by Walter V. Hineman.....	43
Apprentice, Practical suggestions from an, by M. R. Brockman.....	198
Apprentice problem, The car department...	551‡
Apprentice school and shop, Teamwork between, by William L. Lentz.....	255
Apprentice, A suggestion to officers from an, by A. T. Kuehner.....	198
Apprentice school, Getting results in, by Harold V. Styers.....	99

Apprentice school is necessary, An, by William Heise.....	255
Apprentice School, Why have an, by A. B. Kerr.....	651
Apprentice, Turning a boiler maker into a good mechanic, by Daniel Cleary.....	656
Apprentice, The voice of the (competition).	197
Apprentice, What can be done for the, by John C. Murdock.....	259
Apprentices, Air brake, by C. M. Drennen, Air Brake convention.....	301
Apprentices, Car department, by B. F. Patram (First prize, Car Inspectors' and Foremen's competition).....	579
Apprentices, Car department, by C. N. Swanson, Second prize, Car Inspectors' competition.....	639°
Apprentices, A competition for.....	2‡
Apprentices, Freight car.....	1395‡
Apprentices, Freight car carpenter, Santa Fe	403°
Apprentices, Help the, to help themselves, by Millard F. Cox.....	40
Apprentices; Never slight a job, by John V. Le Compte.....	142
Apprentices on the Southern Pacific, by Thomas G. Gray.....	97
Apprentices, Training boilermaker, Santa Fe	415°
Apprenticeship, A broad conception of, by V. T. Kropidowski.....	146
Apprenticeship competition, Prize winners of Car Inspectors' and Foremen's Association	578
Apprenticeship in the drawing room, by Will C. Mooney, Jr.....	276‡
Apprenticeship; Is it not time to wake up?	1444‡
Apprenticeship, The new, by William Johnston.....	256
Apprenticeship on railroads, by F. W. Thomas, M. M. convention.....	1509
Apprenticeship; The right age to start is 18, by Nielsen Pollard.....	255
Apprenticeship, The Santa Fe method of, by T. S. Tulien.....	198
Apprenticeship, Suggestions on.....	44
Apprenticeship, What the boys think of (competition).....	255
Appropriations, Periodical, for material...	167‡
Arch, A correction re Universal Arch Co.'s, by George S. Payson.....	276‡
Arch, The future of the brick.....	385‡
Arch bars, Hand mirror for inspecting the inner side of.....	452°
Arc welded cutting tools, Westinghouse Electric & Mfg. Co.....	1469°
Arc welding in boiler repairs, Boiler Makers' convention.....	312
Arc welding in railroad shops, by Gordon Fox.....	591°
Arc welding, Patch applied by, by W. J. Gillespie.....	660°
Arc welding, Progress in.....	204
Armstrong Cork Co., Corkboard insulation for tank cars.....	1393°
Armstrong, G. W., Essentials of shop efficiency.....	201°
Armstrong, G. W., The selection of machine Tools.....	89
Ash pans, Front ends, grates and, Fuel Association convention.....	282
Ash pans, Inspection of locomotive spark arresters and.....	659
Ashton Valve Co., Locomotive gage.....	1469
Ashton Valve Co., Safety valves.....	1437
Association competition announcement.....	439‡
Association, Help push your (competition).	493‡
Association of Mfrs. of Chilled Car Wheels (see Meetings).	
Association of Mfrs. of Chilled Car Wheels, Work of.....	570
Association of Railway Electrical Engineers (see Meetings).	
Association of Railway Electrical Engineers (see Railway Electrical Engineers' Association).	
Associations, Co-operating with other.....	1472‡
Associations, Co-operation with other mechanical, M. M. convention.....	1493°
Associations, Functions of the mechanical.	493‡
Atchison, Topeka & Santa Fe apprentice conference.....	363°
Atchison, Topeka & Santa Fe, Freight car carpenter apprentices.....	403°
Atchison, Topeka & Santa Fe, High speed steel tipped lathe tools.....	200°
Atchison, Topeka & Santa Fe, Training boilermaker apprentices.....	415°
Atchison, Topeka & Santa Fe, Jacking stall for car repairs.....	535°
Atchison, Topeka & Santa Fe, Refrigerator cars.....	135°

Atchison, Topeka & Santa Fe, Training young men for promotion.....	597
Atchison, Topeka & Santa Fe, 40-ton steel end box car.....	23°
Atlantic Coast Line, Bracket for safety valve test gage.....	39°
Atlantic Coast Line, Double ring tire heater	310°
Atlantic Coast Line, Hose stripping machine	259°
Atlantic Coast Line, Operation of a general flue shop.....	653°
Atlantic Coast Line, Oxy-acetylene welding in boiler repairs.....	649°
Atlantic Coast Line, Portable kerosene vaporizer.....	43°
Atlantic Coast Line, Reclaiming driving boxes.....	206°
Atlantic Coast Line, Special tool holder for broken drills.....	44°
Atlantic Coast Line, Steam gage testing stand.....	310°
Averill, E. A., Operation of radial coupled axles, Discussion at A. S. M. E.....	17
Axle, Gage for checking the location of wheels on the, by Howard W. Stull.....	514°
Axle failure, a locomotive.....	650
Axle journals, Machining locomotive.....	611‡
Axle lighting panel, Consolidated.....	1390°
Axles, Dies for reclaiming car, Blacksmith's convention.....	468°
Axles, Water vs. oil quenching in heat treatment of, by C. D. Young.....	398°

### B

Babbitt metal, Remelting causes inferiority.	179†
Babbitting, Ground asbestos, a substitute for clay in.....	362†
Bailey, E. G., Interpretation of coal analysis, Fuel Association convention.....	285
Bailey Meter Co., Boiler meter.....	375°
Bailey Meter Co., A steam flow meter.....	323°
Baldwin Locomotive Works, Arrangement of throttle and standpipe.....	429°
Ball bearings in lathe construction, Gurney	538°
Baltimore & Ohio, Mallet road locomotives.	389°
Band, The value of the shop.....	549‡
Barker, N. M., A locomotive inspection system.....	369°
Barnes, Edgar, Jig for tube cutters.....	321°
Barnum, E. S., Keeping track of service tests.....	337°
Barnum, E. S., Road tests of exhaust nozzles	67°
Barnum, M. K., Life and maintenance of steel cars.....	129°
Barrel sheets, Cracking of, Boiler Makers' convention.....	316
Bar stock, Plunger for holding, by Edw. F. Glass.....	589°
Basford, George M., Present day locomotive problems.....	509
Batchelder, A. F., Mechanical design of electric locomotives.....	558
Battery plate, New, Gould.....	1392°
Baxter, H. M., Requirements and correct treatment of headlinings.....	580
Bayliss, H. W., The need of uniform equipment on freight cars.....	405
Bearings, Anti-friction, for shop motors.....	142
Bearings, Ball, in lathe construction, Gurney	538°
Belk, M. S., Air brake excess pressure, Air Brake convention.....	304
Belt rail applied to Union Pacific all-steel automobile cars.....	513°
Belt tension device, Safety Car Lighting.....	1436°
Beltting, Removing oil from leather.....	431†
Belts, Guarding overhead.....	134†
Belts, Preparation for leather, Duntley Co.	603
Bendict, B. W., Getting the most out of tools.....	35°
Benica, C. W., Design of hollow crank pins.	66°
Bentley, F. W., Jr., Drift for truing up supply valve stem guides.....	652°
Bettendorf Co., Quick action lever hand brake.....	1394°
Bettendorf Co., Steel frame box car.....	1264°
Blacksmiths' Association convention.....	463°
Blower, Turbo, Ingersoll Rand Co.....	266°
Blower ventilator, Dining car, Mudge & Co.	1265°
Blue print paper, Protecting, Koelsch & Co.	266°
Boiler brace, Flexible, Breakless Staybolt Co.....	1441°
Boiler capacity, The fireman and.....	219‡
Boiler capacity, Saving weight to provide..	219‡
Boiler corrosion, Prevention of, by electricity.....	462
Boiler efficiency.....	440‡
Boiler efficiency, by J. T. Anthony.....	505°

Boiler expansion experiments, by D. R. MacBain .....	496*	Brake equipment, Care of modern passenger, by C. U. Joy, Air Brake convention.....	302	<b>Cars—(Continued)</b>	
Boiler for Baltimore & Ohio Mallet locomotive .....	389*	Brake equipment, Empty and load, by Walter V. Turner.....	355*	Dismantling of, by J. W. Gerber.....	306
Boiler inspection, Better locomotive.....	93*	Brake gear, The foundation.....	82	Door, National; Union Metal Products Co.....	537*
Boiler, Lake Superior & Ishpeming 2-8-0 locomotive .....	343*	Brake, Geared hand, for blind end cars, National Brake Co.....	1314*	Draft arm, Cast steel, Chicago Steel Car Co.....	1312*
Boiler maintenance, Fuel economy vs.....	439†	Brake levers, Manufacturing standard, by W. P. Hobson.....	425*	Draft gear, Friction tandem, Universal Draft Gear Attachment Co.....	1311*
Boiler, The maintenance of the locomotive, by A. R. Hodges.....	257	Brake lever, Trussed, Schaefer Equipment Co.....	1269*	Draft gear, High capacity friction, Waugh .....	1269
Boiler Makers' Association convention.....	311*	Brake, Quick action lever hand, Bettendorf.....	1394*	Draft gear, M. C. B. convention.....	1371*
Boiler plugs, Failure of fusible tin.....	10	Brake rods, Making bottom, without welds, by Walter Constance.....	37*	Draft gear, Rocker, Railway Supply & Equipment Co.....	1310*
Boiler preservative, Flexible Bolt Co.....	1438	Brake shoe and brake beam equipment, M. C. B. convention.....	1293*	Drain and double trap, Santa Fe Refrigerator, Southern Ry.....	138*
Boiler preservative, Flexible Bolt Co., a correction .....	1506	Brake shafts, Drill jig for, Tool Foremen's convention .....	475*	Express refrigerator, Nor. Pac.....	62*
Boiler repairs, Electric welding in, Boiler Makers' convention .....	312	Brake system, Moisture in locomotive, by Mark Purcell, Air Brake convention.....	303	Four-wheel truck for passenger, discussion by A. S. M. E.....	27
Boiler repairs, Oxy-acetylene process in, Boiler Makers' convention.....	311	Brakes, Clasp, for heavy passenger equipment cars, by T. L. Burton.....	581*	Freight center sills, Ratio of stress to end load for, by C. M. Faris.....	127*
Boiler repairs, Oxy-acetylene welding in.....	649*	Brakes, Maintenance of freight, Air Brake convention .....	300	Freight, construction, maintenance and abuse, by C. J. Wymer.....	139
Boiler steel, Corrosion and.....	494‡	Brakes on mountain grades, Hand.....	308	Freight, Defective .....	1396‡
Boiler steel, The microscope and.....	494‡	Braking of long passenger trains, Proper.....	495‡	Freight, Dismantling .....	1355‡
Boiler tubes, Care of, by Joseph Smith.....	321	Brass and bronze, Waste and abuse of, by Russell R. Clarke.....	361	Freight, Maintenance, by H. H. Harvey, Car Inspectors' convention.....	638
Boiler tubes, The dimensions of.....	1424‡	Brass, Effect of rolling on strength of.....	602†	Freight, Maintenance, by L. J. Justus, Car Inspectors' convention.....	637
Boiler tubes and shells, Pitting of.....	1470	Brass, Langton driving box.....	261*	Freight, The need of uniform equipment on, by H. W. Bayliss.....	405
Boiler wall coating, H. W. Johns-Manville Co.....	430*	Brasses, Fitting driving box, by V. T. Kropidowski.....	360*	Freight, Orders in 1916.....	1247‡
Boilers, Cleaning, with tubes removed, Boiler Makers' convention.....	317	Brasses, Fitting up journal.....	581	Freight, Rehabilitation of.....	1355‡
Boilers, Design and maintenance of, M. M. convention .....	1480	Brasses, Holding down wheels while changing, by W. E. Lemp.....	307*	Freight, Repairing, by F. C. Schultz, Car Inspectors' convention.....	642
Boilers, Patching .....	196*	Brasses, Tool for reclaiming car.....	452*	Freight, A suggestion for a composite construction .....	29
Boilers, Prevention of scaling in.....	536†	Brazier, F. W., Address at Car Inspectors' and Foremen's convention.....	572	Freight, The weight of steel.....	331‡
Boilers, Report of the chief inspector of locomotive .....	41*	Breakless Staybolt Co., Flexible boiler brace Brewster, E. J., Expanding mandrel for turning locomotive tires.....	37*	Gondola, 70-ton, Pennsylvania.....	406*
Bolt extractor, John A. Magnusson.....	1438*	Breyer, J. S., Enginehouse methods, (competition) .....	461	Gondola, 70-ton, Wheeling & Lake Erie Gondola, Service of 90-ton, Norfolk & Western .....	194
Bolt holes in castings, Spacing.....	376†	British goods locomotives, Modern, by E. C. Poultney.....	621*	Headlinings, The essential requirements and correct treatment of, by H. M. Baxter .....	580
Bolts and nuts, Efficient reclamation of, by E. T. Spidy.....	33*	Brockman, M. R., Practical suggestions (apprentice competition) .....	198	Headlinings, Treatment of light-colored, Painters' convention .....	518
Bonnett, Robert, Fusible crown sheet plug.....	427*	Bronze, Waste and abuse of brass and, by Russell R. Clarke.....	361	Hood construction; Can. Nor. dining car .....	79
<b>Books</b>		Brown, H. M., Chesapeake & Ohio scrap reclamation .....	149*	Hopper coiler for India.....	183*
Coal, its economical and smokeless combustion, by J. F. Cosgrove.....	551	Brown, R. E., Hose stripping machine.....	259*	Hopper, Steerer end slopes for, by F. S. Ingoldsby .....	459
Corrosion of iron, by L. C. Wilson.....	221	Brown, H. M., Rivet cutter for freight car repairs .....	419*	Hopper, 200,000-lb., Woodward Iron Co. 50 ton Hopper, Erie Railroad.....	457*
General Foremen's Association proceedings .....	59	Buda Co., Incandescent headlight.....	1441*	Letter board splice, Can. Nor.....	128*
How to build up furnace efficiency, by Joseph W. Hayes.....	613	Buell, D. C., President's address at Fuel Association convention .....	277	Lichtine system, Stone-Franklin.....	1267*
Inventions and patents, by Philip E. Edelman .....	387	Buffalo, Rochester & Pittsburgh, Rack for storing smoke box front ends.....	651*	Observation, Trap doors on.....	357
Laboratory test of a Consolidation Locomotive, by E. C. Schmidt et al.....	59	Buffers, Interlocking fenders and collision, British .....	411*	Passenger, Buffer, Waugh.....	1313
Locomotive engine running and management by Angus Sinclair.....	167	Burner, Oil, with preheating arrangement, Hauck .....	1436*	Passenger, Can. Nor.....	77*
Mechanical drawing by James D. Phillips and Herbert D. Orth.....	3	Burns, George J., Grease lubrication of locomotive driving boxes.....	234	Passenger, Cleaning .....	219‡
Mechanical engineers' handbook, by Lionel S. Marks, editor-in-chief.....	333	Burton, T. L., Clasp brakes for heavy passenger cars .....	581*	Passenger, Cleaning and sanitation, by E. P. Marsh.....	579
Mechanical engineers' pocket-book by William Kent .....	167	Buying, Do your equipment, Early.....	613‡	Passenger, Clearance diagrams for.....	439‡
National Association of Corporation Schools, Annual convention report.....	387	<b>C</b>		Passenger, Design of, by Victor W. Zilen .....	189*
Oil fuel equipment for locomotives, by Alfred H. Gibbins.....	441	Cairns, M. J., Locomotive piping and jackets Cairns, M. J., Safety valves.....	420*	Passenger, Electric ceiling fan for.....	428*
Oxy-acetylene welding and cutting, electric and thermit welding.....	113	Camera in a railroad shop, The, by C. L. Dickert .....	422*	Passenger, An enamel finish for, Pratt & Lambert, Inc.....	1313
Power transmission by leather belting, by Robert Thurston Kent.....	441	Canadian Government Railways, Sleeping cars .....	644*	Passenger, Standardizing parts.....	1279‡
Principles and practice of cost accounting, The, by Frederick H. Baugh.....	441	Canadian Government Railways, Water coolers for passenger cars.....	460*	Passenger radiators, Tests of, M. M. convention .....	1459*
Principles of locomotive operation and train control, by Arthur J. Wood.....	275	Canadian Northern, Auxiliary car for wrecking cranes .....	21*	Passenger seat, Scarritt-Comstock Furniture Corp.....	538*
Proceedings of the tenth annual convention of the Master Boiler Makers' Association .....	495	Canadian Northern, Letter board splice.....	128*	Passenger, Smoke jack for, Can. Nor.....	308*
Proceedings of the traveling Engineers' Association .....	167	Canadian Northern passenger cars.....	77*	Passenger tail gate, Acme folding.....	324*
Proceedings of the twenty-third annual convention of the International Railway Master Blacksmiths' Association.....	113	Canadian Northern, Smoke jack for passenger cars .....	308*	Passenger, Terminal cleaning of, by J. E. Ross (competition) .....	297
Scientific management and labor, by R. F. Hoxie .....	221	Canadian Northern, Vacuum cleaner.....	27*	Passenger trimmings, Removal of, Painters' convention .....	518
Tool Foremen's Proceedings.....	3	Canadian Northern, Wheel clamp and jack block .....	22*	Passenger, Water coolers for, by George E. McCoy .....	460*
Boosters, An opportunity for.....	439‡	Canadian Pacific, A reclaimed rail saw.....	359*	Passenger, Windows .....	440‡
Booth Co., L. M., Water softener.....	324*	Canadian Pacific, Efficient reclamation of bolts and nuts .....	33*	Postal skylight, Can. Nor.....	81*
Borer, Frank J., Help the apprentice to help himself .....	92	Capacity, High locomotive, and low axle weight .....	386‡	Refrigerator and heater, Automatic.....	662*
Borer, Frank J., Pneumatic clamping and holding-on devices .....	655*	Capacity, Increased locomotive .....	58‡	Refrigerator and heater, Moore type.....	208*
Boring bar (see Machine Tools).		<b>Cars</b>		Refrigerator, Brine tank valve.....	322*
Borings, Briquetting press for metal, Hydraulic Press Mfg. Co.....	539*	Aisle strips, Depressed, Union Pacific.....	402*	Refrigerator, Santa Fe .....	135*
Boston & Maine, Steel coaches.....	349*	All-steel and composite construction, Comparison of, by K. F. Nystrom.....	191*	Reinforced wooden, Settlement prices for, M. C. B. Convention.....	1302
Bottom brake rods, Making, without welds, St. L. & S. F.....	37*	Auxiliary, for wrecking cranes, Can. Nor.....	21*	Rail parts, Numbering, by W. H. Hauser .....	237*
Boutell, Hugh G., Coal counter for use in locomotive tests .....	120*	Box, Buffering stresses in, by R. N. Miller .....	409*	Repairs, Special tools for.....	456
Boutell, Hugh G., Interesting facts concerning grade resistance and car friction.....	345	Box, Door lock, Triplex Lock Co.....	540*	Roof, Steel, for box cars.....	75*
Boutell, Hugh G., A plea for the draftsman .....	60†	Box, Horizontal sheathing for, by W. E. Fowler .....	334*†	Sanitation of, by Thomas R. Crowder.....	241
Boutell, Hugh G., Triangle for use in tracing .....	568*	Box, Horizontal sheathing on.....	111‡	Seat, Double reclining, Heywood Bros. & Wakefield .....	1268*
Bowman, J. C., First prize article, apprentice competition .....	197	Box, Shrinkage of sheathing.....	408	Sheathing, Leakage of horizontal, by A. E. Heffelfinger .....	276*‡
Bowser & Co., Inc., S. F., Oil pumps with quick return stroke.....	1390	Box, Steel roof for.....	75*	Skylight for postal car roof, Can. Nor.....	81*
Bradley, Ralph, The human fireman, Fuel Association convention .....	286	Buffers, Interlocking fenders and collision, British passenger.....	411*	Sleepers, Canadian Government Railways .....	644*
Brake and signal equipment, M. C. B. convention .....	1290*	Caboose, Steel frame single sheathed, N. C. & St. L.....	511*	Steel automobile, Belt rail applied to Union Pacific .....	513*
Brake beam hanger, drop-forged, Q & C Co.....	1261*	Construction, An effect of poor.....	1396‡	Steel box, The building of, on the Pennsylvania .....	193*
Brake beam safety hangers.....	1279‡	Construction, M. C. B. convention.....	1379	Steel end box, Santa Fe.....	23*
Brake beam support, Ajax third point, American Steel Foundries Co.....	156*	Coupler centering device, Oliver Iron & Steel Co.....	1267*	Steel frame automobile, Wheeling & Lake Erie .....	401*
Brake beam support, Third point, Creco.....	1262*			Steel frame box, Bettendorf Co.....	1264*



<b>Cars—(Continued)</b>			
Steel, Life and maintenance of, by M. K. Barnum	129*	Chesapeake & Ohio, Babbitting crossheads.	462*
Steel, Maintenance of	112*	Chesapeake & Ohio, Boiler steel cylinder patch	655*
Steel ore, Duluth, Missabe & Northern	354*	Chesapeake & Ohio, Boiler washer's hose cart	260*
Steel passenger, Boston & Maine	349*	Chesapeake & Ohio, Chuck for the manufacture of flue cutter blades	88*
Steel passenger, England's idea of the	220*	Chesapeake & Ohio, Eccentric keyway cutter	596*
Steel passenger, roofs and decks, Treatment of, Painters' convention	515	Chesapeake & Ohio, Gage glass cutter	660*
Steel passenger, The weight of the	1356*	Chesapeake & Ohio, Grinding dry pipe joints	425*
Steel, Preserving the life of, by H. M. Clarence	403	Chesapeake & Ohio, Manufacturing standard brake levers	425*
Tank, M. C. B. convention	1399*	Chesapeake & Ohio, Molding gaskets for feed valves	320*
Tank, specifications modified	128	Chesapeake & Ohio, Pipe bending machine	321*
Trap and drain, Double for Santa Fe refrigerator cars	138*	Chesapeake & Ohio, Pneumatic riveting machine	656*
Underframe, Canadian Northern dining cars	78*	Chesapeake & Ohio, Portable air hoist	480*
Underframes, Boston & Maine steel coaches	349*	Chesapeake & Ohio, Portable tire heater	258*
Underframes, Reinforcing of	111*	Chesapeake & Ohio, Rivet cutter for freight car repairs	419*
Vestibule trap door, Transportation Utilities Co.	1262*	Chesapeake & Ohio scrap reclamation, by H. M. Brown	1262*
Wooden, Inadequate reinforcement of	1396*	Chicago & Eastern Illinois, Numbering repair parts of cars	237*
Car and Locomotive Painters' Association (see Painters' Association).		Chicago & Eastern Illinois, Removing air pockets from reservoirs	372*
Car department, Better men needed in the	1397*	Chicago & Eastern Illinois, Straightening press for steel car members	526*
Car department convention, An important	441*	Chicago & North Western, Carboy holder	321*
Car department, The crying need of	59*	Chicago & North Western, Expanding mandrel for turning locomotive tires	37*
Car department, General foremen and the	494*	Chicago & North Western, Powdered coal in engine service	565*
Car department, Problems of the, by E. E. Griest	453*	Chicago & North Western, Turning car journals	128*
Car department problems, General Foremen's convention	528	Chicago, Burlington & Quincy, Locomotive impact tests	288*
Car department, Special tools for the	452*	Chicago, Burlington & Quincy, Reclaiming car truck pedestals	82*
Car design, Reducing weight in	165*	Chicago, Burlington & Quincy, Steel box car roof	75*
Car design, Suggestions for improvement in (competition)	347	Chicago Pneumatic Tool Co., Boyer pedestal riveter	603*
Car designer, Co-operation with, by A. H. Lake (competition)	460	Chicago Pneumatic Tool Co., Capacity regulation for air compressors	1468
Car designer, How can the, improve?	331*	Chicago Pneumatic Tool Co., Fuel oil driven air compressor	261*
Car designer, How can the, improve? (competition)	165*	Chicago Railway Equipment Co., Third point brake beam support	1262*
Car designer, Suggestions for the, by Cyrus Hankins (competition)	456	Chicago, Rock Island & Pacific, Fuel economy on	180
Car door fasteners, Effective, Universal Car Seal & Appliance Co.	103*	Chicago Steel Car Co., Draft arm	1312*
Car Foremen's Association of Chicago (see Meetings).		Chief Interchange Car Inspectors' and Car Foremen's Association (see Car Inspectors' and Car Foremen's Association).	
Car foreman's responsibility for air brake condition, by Lawrence Wilcox	134	Chief Interchange Car Inspector's and Car Foremen's Association (see Meetings).	
Car inspector and his job, The	85	Chinnock, Fred, Better locomotive boiler inspection	93*
Car inspector and his job, The (competition)	451	Chisels, by Henry Fowler	204*
Car inspector, How to develop the (Competition Articles)	305	Christy, G. C., The importance of the round-house foreman	421
Car inspector's position, Dignifying the	1280*	Chuck for driving traps, Scully-Jones & Co.	208*
Car inspector, The work of the, by W. F. Mandrell	353	Clamping and holding-on devices, Pneumatic, by Frank J. Borer	655*
Car Inspectors' and Car Foremen's Association (see Meetings).		Clancy, J. H., Pneumatic spring shear and bender	596*
Car Inspectors' and Car Foremen's Association convention	571*	Clarence, H. M., Preserving the life of steel cars	408
Car Inspectors' and Car Foremen's Association, Relation of higher officers	549*	Clark, W. S., The car inspector and his job (competition)	451
Car Inspectors' and Car Foremen's Association, Thoughts suggested by Indianapolis convention	569	Clarke, Russell R., Efficiency in scheming	250
Car Inspectors' and Car Foremen's convention	637*	Clarke, Russell R., Waste and abuse of brass and bronze	361
Car inspectors, How to keep, by A. C. Shinnaver	298	Clay for babbitting	362†
Car inspectors, Making efficient, by H. D. Wolcomb	31	Cleaning and sanitation, Passenger car, by E. P. Marsh, Car Inspectors' convention	579
Car inspectors, Qualifications and training of, by Millard F. Cox	181	Cleaning methods, effects of water and oil on paints, Painters' convention	519
Car inspectors, The responsibility of	221*	Cleaning of passenger cars, Terminal, by J. E. Ross (competition)	297
Car repairs and billing, Foreign, by E. S. Way	185*	Cleaning passenger cars for varnishing, Use of soap in, Painters' convention	524
Car repairs, Jacking stall for steel, Santa Fe	535*	Cleary, Daniel, Turning a boiler maker apprentice into a good mechanic	656
Car repairs, Shopping for classified, passenger, Painters' convention	519	Clerk, How about your chief	1472*
Car repairs, Special tools for steel, Tool Foremen's convention	472*	Clerk, The mechanical department	168†
Car repairs, Systematic, by F. G. Lister	248	Clerk, The mechanical department, 168†, 221†, 267†	
Car replacers, Reading Specialties Co.	1469*	Cleveland, Cincinnati, Chicago & St. Louis, Injector steam pipe roller and expander	525*
Car terminal competition, The	219*	Clinboard for analyzing indicator cards, by H. K. Fox	504*
Car terminal competition, Prize article by R. S. Mounce	239*	Clouser, George S., College men in the mechanical department	334†
Car terminal yard, The passenger, by W. W. Warner	402	Central of Georgia, Material delivery at the Macon shops	359
Carbic Mfg. Co., Flare light	1436	Coal analysis, Interpretation of, by E. G. Bailey, Fuel convention	285
Carboy holder, Chicago & North Western	321*	Coal ash, Composition of	422†
Carney, J. A., Address at Tool Foremen's convention	479	Coal consumption, Locomotive	69*
Carpet stretcher, by C. C. Leech	348*	Coal counter for use in locomotive tests, by Hugh G. Boutell	120*
Cart, Boiler washer's hose, by E. A. Murray	260*	Coal, Powdered, in engine service, by C. W. Corning	565*
Case hardening, by P. F. Dugan	535	Coal, The prevention of spontaneous combustion of, by J. F. Springer	179
Castings, Preparing iron for malleable	342†	Coal, Spontaneous combustion of, by J. F. Springer	124
Catalogues	56, 110, 164, 217, 272, 330, 384, 491, 548, 610	Coal, Suggestions for team work in saving	10
Cement, Fire brick, Quigley Furnace Specialties Co.	1506	Coal, The use of pulverized, as a fuel, by Joseph Harrington	399
Cement for steam pipes	483†	College men in the mechanical department	1509*
Center Sills, Ratio of stress to end load for freight cars, by C. M. Faris	127*	College men in the mechanical department, by George S. Clouser	334†
Central Electric Co., Electric ceiling fan for passenger cars	428*	Combustion of coal, Spontaneous, by J. F. Springer	124
Central of Georgia, Enginehouse practice at Macon	319*		
Central of Georgia, Grinding rod packing cone rings	310*		
Central Railroad of New Jersey, Pneumatic clamping and holding-on devices	655*		
Central Railway Club (see Meetings).			
Chart for determining the expansion of metals, by W. F. Schaphorst	504*		
		Committees, Co-operate with the	1443*
		Committee reports, The character of	1424*
		Committee work, Obstructing	1280*
		Competition for apprentices, A	2*
		Competition, The apprentice	57*
		Competition, Car department apprentice	1280*
		Competition, The car terminal	219*
		Competition, The enginehouse	112*
		Competition, How can the car designer improve?	165*
		Competition, Passenger car terminal	57*
		Competition, Steel freight car, award	1*
		Competition: What is heat-treated steel?	165*
		Competitions, Our prize	549*
		Competitions, The Prize	611*
		Compressors, Capacity regulation for air, Chicago Pneumatic Tool Co.	1468
		Condenser, Beyer barometric, Ingersoll-Rand Co.	373*
		Connector, Robinson automatic train line	482*
		Consolidated Railway Electric Light & Equipment Co., Axle light panel	1390*
		Constance, Walter, Making bottom brake rods without welds	37*
		Convention, An important car department	441*
		Convention papers and discussion	273*
		Convention reports, Advance copies of	1423*
		Convention stories, The two	549*
		Convention, Thoughts suggested by Indianapolis	569
		Conventions: Chicago or Atlantic City?	1473*
		Conventions in August and September, Mechanical	387*
		Conventions, Railway mechanical	220*
		Conventions, The young men at	1443*
		Cook, George, Getting results from a big engine terminal (competition)	372
		Copper, Brittleness of annealed	480†
		Copper Range Railroad, A locomotive inspection system	369*
		Copyright, Notice of	1247*
		Corbett, W. H., Education of the road foreman, the engineer and the fireman, M. M. convention	1494
		Corning, C. W., Pulverized coal in engine service	565*
		Correspondence, Filing of, by W. C. Hunt, Storekeepers' convention	291
		Correspondence, Large cut in	60†
		Corrosion and boiler steel	494*
		Corrosion, Prevention of boiler, by electricity	462
		Corrosion, Prevention of, in pipe, by F. N. Speller	227
		Costkeeping for railroad shop power, M. M. convention	1494*
		Cost of small shop tools, by J. J. Sheehan, M. M. convention	1528*
		Cost versus service	58*
		Costs, Locomotive repair facilities and	273*
		Costs, Mechanical department	1507*
		Costs needed in reclamation work	166*
		Costs, Shop power	1507*
		Cotter Supply Company, G. F., Piston valve chamber for slide valve cylinders	430*
		Counterbalances, Locomotive, by W. E. Warner, General Foremen's convention	528*
		Coupler centering device, Oliver Iron & Steel Co.	1267*
		Coupler pocket, Adjustable, American Steel Foundries Co.	1312*
		Coupler, The standard M. C. B.	1355*
		Coupler yoke, Murray hinged, Keyoke Ry. Equipment Co.	47*
		Couplers and parts, Marking of, Storekeepers' convention	291
		Couplers, M. C. B. committee report	1364*
		Couplers, Truck for carrying	452*
		Couplings, Dimensions for flange and screw, for injectors, M. M. convention	1455
		Cox, Millard F., Help the apprentices to help themselves	40
		Cox, M. F., Locomotive power reverse gear	602*
		Cox, Millard F., Qualifications and training of car inspectors	181
		Cox, Millard F., Some lessons from experience with steel freight cars	26
		Cox, Millard F., Toning up an organization	95
		Crane trolley, Whiting	431*
		Crank pins, Design of hollow, by C. W. Benica	66*
		Crawford, E. C., Second prize article, apprentice competition	197
		Crosby Steam Gage & Valve Co., Locomotive safety valve	1442*
		Crossheads, Babbitting, by H. C. Gillespie	462
		Crowder, Thomas R., The sanitation of railway cars	241
		Cup plug, A simple, by John P. Risque	414*
		Curtain fixtures, Enclosed, Acme Supply Co.	482*
		Curtain roller, Spring plug, National Lock Washer Co.	1261*
		Cushion cleaning machine, Imperial Car Cleaner Co.	1394*
		Cylinder bushings, Design and materials for, M. M. convention	1496*
		Cylinder patch, Boiler steel, by W. P. Hobson	655*
		Cylinder weld, A record	199*

D

Page numbers under 1,000 refer to *Railway Mechanical Engineer*; those over 1,000 refer to the *Daily Railway Age Gosssett*. \*Illustrated article; †editorial; ‡short non-illustrated article or note; †communication.

- Delaware, Lackawanna & Western, Heavy 4-6-2 locomotive ..... 4\*
- Design and materials for pistons, valves, rings and bushings, M. M. convention..... 1496\*
- Design, Alloy steel in locomotive, by L. R. Pomeroy, M. M. convention..... 1499\*
- Design of electric locomotives, Mechanical, by A. F. Batchelder..... 558
- Design of hollow crank pins, by C. W. Benica ..... 66\*
- Design of locomotives to suit conditions... 1443§
- Design, Locomotive front end..... 1444§
- Design, maintenance and operation of electric rolling stock, M. M. convention..... 1490\*
- Design of passenger equipment, by Victor W. Zilen ..... 189\*
- Design, Reducing weight in car..... 165§
- Designer, Co-operation with the car, by A. H. Lake (competition) ..... 460
- Designer, How can the car improve? (competition announcement) ..... 165§
- "Detector," The I. C. C. .... 442†
- Detentions from a new angle, by S. E. Sellman ..... 296
- Detroit Lubricator Co., Improvement in Detroit flange oiler ..... 1440
- Detroit Valve Co., Detroit ball valve..... 155\*
- Dickert, C. L., The camera in a railroad shop ..... 422\*
- Dickert, C. L., Enginehouse practice at Macon, Ga. .... 319\*
- Dickert, C. L., Value of attractive shop grounds ..... 61\*†
- Distributing valves, Holding, in making repairs, by E. H. Wolf ..... 142\*
- Dodge Metal Hose Co., Air brake hose.... 1314\*
- Donellon, J. F., Enginehouse practice..... 595
- Door, National car, Union Metal Products Co. .... 537\*
- Doorways, Safeguarding dangerous ..... 82†
- Draft arm, Cast steel, Chicago Steel Car Co. .... 1312\*
- Draft for stationary boilers, Balanced..... 661\*
- Draft gear capacity ..... 1355§
- Draft gear, Friction tandem, Universal Draft Gear Attachment Co. .... 1311\*
- Draft gear, High capacity friction, Waugh. .... 1269
- Draft gear maintenance, Slack and..... 57§
- Draft gear, M. C. B. convention..... 1371\*
- Draft gear, Rocker, Railway Supply & Equipment Co. .... 1310\*
- Draftsman, A plea for ..... 60†
- Draper Mfg. Co., Furnace attachment for reclaiming boiler tubes ..... 1470
- Drawing room apprenticeship in the, by Will C. Mooney, Jr. .... 276†
- Drawing room tonic, by Millard F. Cox.... 95
- Drennen, C. M., Air brake apprentices, Air Brake convention ..... 301
- Drill (see Machine Tools).
- Drill, Compound-gear pneumatic, Ingersoll-Rand Co. .... 211\*
- Drill jig for brake staffs, Tool Foremen's convention ..... 475\*
- Drills, Abuse of high speed ..... 120†
- Drilling machine (see Machine Tools).
- Drilling post, Old man, by Leroy Smith..... 589\*
- Driving box brass, Langton ..... 261\*
- Driving box brasses, Fitting, by V. T. Kropidowski ..... 360\*
- Driving box repairs, by R. L. Preston..... 100\*
- Driving box shoe and wedge faces, Method of facing, Union Pacific..... 652\*
- Driving boxes, Grease lubrication of, by George J. Burns ..... 234
- Driving boxes, Grease lubrication of, by John V. Le Compte ..... 388†
- Driving boxes, Lateral motion ..... 223\*
- Driving boxes, Lateral motion, and side play ..... 333§
- Driving boxes, Reclaiming, by R. P. Peterman ..... 206\*
- Drop forging, Blacksmiths' convention..... 465
- Drop pit, Improved, Pamplin & Morton..... 154\*
- Dry pipe joints, Grinding, by H. C. Gillespie ..... 425\*
- Duff Mfg. Co., Geared automatic lowering jack ..... 1437\*
- Dugan, P. F., Case hardening ..... 535
- Dunluth, Missabe & Northern, Steel ore car ..... 354\*
- Dunn, S. O., Address at Fuel Association convention ..... 278
- Duntley Co., Preparation for leather belts..... 603
- Dynamometer car, Southern Railway..... 62\*
- Eight-hour day question, The..... 550§
- Electric furnaces for tempering tools, Illinois Central ..... 423\*
- Electric headlight (see Headlight).
- Electric rolling stock, Design, maintenance and operation of, M. M. convention..... 1490\*
- Electric Storage Co., Body-hung axle generator ..... 1393
- Electric welding, Oxy-acetylene and, Blacksmiths' convention ..... 469
- Electric welding tube safe ends..... 653\*
- Electrical department? Why the..... 1356§
- Electrification and smoke investigation in Chicago ..... 3§
- Electrification in Chicago, Smoke and..... 11\*
- Electrification, Norfolk & Western..... 121\*
- Electrode holder for electric welding and cutting, by C. W. Schane..... 659\*
- Elfe, W. W., Grinding rod packing cone rings ..... 310\*
- Elgin, Joliet & Eastern, Boiler shop devices. Elwell-Parker Electric Co., Elevating platform truck ..... 1391\*
- Enamel coach finish, Pratt & Lambert, Inc. Engineer, How best to educate the, M. M. convention ..... 1494
- Engineer Co., The, Balanced draft for stationary boilers ..... 661\*
- Engine failures, Analyzing, by A. Park (competition) ..... 366
- Enginehouse and the tool foreman, The.... 493§
- Enginehouse competition, The..... 112§
- Enginehouse, Getting results in an, by Thomas F. Ryan (competition)..... 424
- Enginehouse, Jigs and devices for the, Tool Foremen's convention ..... 478\*
- Enginehouse management, Some points in, by C. E. Kelly (competition) ..... 426
- Enginehouse methods, by J. S. Breyer (competition) ..... 461
- Enginehouse organization, by C. C. Leech (competition) ..... 469
- Enginehouse organization, Efficient, by E. W. Smith ..... 143\*
- Enginehouse practice, by J. F. Donellon (competition) ..... 595
- Enginehouse practice at Macon, Ga., by C. L. Dickert ..... 319\*
- Enginehouse work, Specializing..... 220§
- Engine terminal competition, The..... 2§
- Engine terminal, Getting results from a big, by George Cook (competition)..... 372
- Engine terminal, Handling a big, by Paul A. Schenck ..... 251
- Engine terminal, Handling a big, by Harvey de Witt Wolcomb (competition)..... 417\*
- Engine terminal, Operating a large, by F. W. Schultz (competition)..... 205
- Engine terminal, The operation of a large, by T. H. Adams (competition)..... 368
- Engine terminals, Some notes on, by George Twist ..... 252
- Equalization of long locomotives, M. M. convention ..... 1488\*
- Equipment, Design of new..... 112§
- Equipment, Do your, buying early..... 613§
- Equipment, Rails and, Report of committee on, to the National Association of Railroad Commissioners ..... 76
- Equipment, Retrenchment as affecting..... 1248§
- Eric Railroad, 50-ton hopper cars..... 457\*
- Eric Railroad, 2-10-2 type locomotive..... 223\*
- Executive, The making of an..... 611§
- Exhibit, New devices on, at Atlantic City..... 1249§
- Exhibit, Railway Supply Manufacturers' Association ..... 1270
- Exhibits, Additional ..... 1384
- Exhibits at Atlantic City described during the year ..... 1260
- Exhibits at Atlantic City described during the year ..... 1435
- Exhibits, Railway Supply Manufacturers' Association, Additional ..... 1384
- Exhibits, Visiting the, in groups..... 1279§
- Exhibitors, Tips to ..... 1248§
- Exhaust nozzle, A variable..... 400\*
- Exhaust nozzles, Road tests of, by E. S. Barnum ..... 67\*
- Exhaust pipe seats, Union Pacific extension. Expanding mandrel for turning locomotive tires, C. & N. W. .... 37\*
- Exports of railway supplies..... 614†
- Fan, Electric ceiling, for passenger cars, Central Electric Co. .... 428\*
- Faris, C. H., Ratio of stress to end load for freight cars ..... 127\*
- Faris, C. H., Suggestions for improvement in car design (competition)..... 347
- Faris, C. H., Tables for determining the moment of inertia of rectangles..... 184
- Feed water heater question..... 58†
- Felton, S. M., Address at Fuel Association convention ..... 277
- Firebox proportions, Locomotive, by Lawford H. Fry ..... 392
- Fireboxes, Removing and replacing wide, Boiler Makers' convention..... 314
- Fire doors, automatic ..... 331§
- Fire extinguisher, Iland, Johns-Manville.... 1506\*
- Fireman and boiler capacity, The..... 219†
- Fireman, How best to educate the, M. M. convention ..... 1494
- Fireman, The human, by Ralph Bradley, Fuel Association convention..... 286
- Fire Protection Association, Fuel oil installation for small shops, recommended by.... 590\*
- Flange oiler, Improvement in the Detroit automatic ..... 1440
- Flexible Bolt Co., Boiler preservative..... 1438
- Flexible Bolt Co., Boiler preservative, A correction ..... 1506
- Flue shop, Operation of a general, by R. B. Van Wormer ..... 653\*
- Flue welder attachment for reclaiming boiler tubes, Draper Mfg. Co..... 1470
- Forge, Oil rivet, Mahr..... 1438\*
- Forge shop practice, by V. T. Kropidowski. Foreman, How best to educate the, the engineer and the fireman, M. M. convention... 1494
- Foremen and the car department, General... 494§
- Foremen, Relation of, to men, by T. E. Freeman, General Foremen's convention... 533
- Forge shop, Special tools for the, Tool Foremen's convention ..... 475\*
- Forging, Drop, Blacksmiths' convention..... 465
- Formers, Tools and, Blacksmiths' convention ..... 466\*
- Formulas, The Kiesel train resistance, by A. J. Wood..... 627
- Fowler, G. L., Operation of radial coupled axles, discussion at A. S. M. E. .... 19
- Fowler, Henry, Chisels..... 204\*
- Fowler, W. E., Horizontal sheathing for box cars ..... 334\*†
- Fox, Gordon, Electric welding in railroad shops ..... 591\*
- Fox, H. K., Clipboard for analyzing indicator cards ..... 504\*
- Frame making and repairing, Blacksmiths' convention ..... 463\*
- France, Express locomotives in, by Edouard Sauvage ..... 231\*
- Franklin Railway Supply Co., Stone-Franklin lighting system ..... 1267\*
- Freeman, T. E., Relation of foremen to men, General Foremen's convention.... 533
- Freight, Loss and damage to..... 549†
- Freight, Refrigerating, in transit, by M. E. Pennington ..... 585\*
- Friction, car, Interesting facts concerning grade resistance and ..... 345
- Frogs and crossings, Blacksmiths' convention ..... 467
- Front end design..... 1444†
- Front ends, Altering locomotive..... 220†
- Front ends, grate and ash pans, Fuel Association convention ..... 282
- Fry, Lawford H., Locomotive firebox proportions ..... 392
- Fry, Lawford H., What is heat treated steel? ..... 335\*
- Fuel analysis, Interpretation of, by E. G. Bailey, Fuel Association convention..... 285
- Fuel Association convention..... 275†
- Fuel Association convention report..... 277
- Fuel hinder, French..... 92†
- Fuel cost and fuel economy..... 493†
- Fuel economy and smoke prevention, M. M. convention ..... 1475\*
- Fuel economy, by H. C. Woodbridge..... 71
- Fuel economy, Locomotive..... 1472†
- Fuel economy, Locomotive maintenance and, by A. N. Willis, Fuel Association convention ..... 281
- Fuel economy on the Rock Island..... 180
- Fuel economy vs. boiler maintenance..... 439†
- Fuel economies at stationary plants..... 57†
- Fuel inspector, Function of a railroad, by Eugene McAnliffe, Fuel Association convention ..... 286
- Fuel, Powdered, Fuel Association convention ..... 279
- Fuel, Pulverized, for locomotives..... 1508§
- Fuel, Pulverized, for locomotives, by J. E. Muhlfield ..... 114\*
- Fuel, Saving oil and wasting..... 331†
- Fuel stations, Fuel Association convention... 283
- Fuel, Suggestions for team work in saving... 10
- Fuel, The use of powdered, in locomotives, M. M. convention ..... 1511
- Fuels, Low-grade, in producers..... 362†
- Furnace, Lead pot, for heat treatment of steel, Tool Foremen's convention..... 473\*
- Furnaces for tempering tools, Electric, Illinois Central ..... 423\*
- Furnaces, Oil burning forge, Mahr..... 1391\*
- Furnaces, Types of electric..... 595†
- Fusible crown sheet plug, Robert Bonnett... 427\*
- Fusible plug, The, Boiler Makers' convention 316
- E**
- Eaton, G. M., Chattering wheel slip in electric locomotives ..... 178\*
- Eccentric keyway cutter, by E. A. Murray... 596\*
- Eccentric keyways, Laying out, by R. S. Mounce ..... 92\*
- Economy Devices Corp., Intercepting valve for Mallet locomotives..... 263\*
- Economy, Fuel, on the Rock Island..... 180
- Edison Storage Battery Co., Portable emergency lighting unit..... 1439\*
- Educational agencies, Officers should advise men concerning..... 332§
- Efficiency engineer, A word for the..... 222†
- Efficiency, Essentials of shop, by G. W. Armstrong ..... 201\*
- Efficiency of railroad operation, by S. O. Dunn, address at Fuel Association convention ..... 278
- Efficiency in scheming, by Russell R. Clarke ..... 250
- Efficiency in shop output, Real, by John V. Le Compte ..... 99
- F**
- Fan, Electric ceiling, for passenger cars, Central Electric Co. .... 428\*
- Faris, C. H., Ratio of stress to end load for freight cars ..... 127\*
- Faris, C. H., Suggestions for improvement in car design (competition)..... 347
- Faris, C. H., Tables for determining the moment of inertia of rectangles..... 184
- Feed water heater question..... 58†
- Felton, S. M., Address at Fuel Association convention ..... 277
- Firebox proportions, Locomotive, by Lawford H. Fry ..... 392
- Fireboxes, Removing and replacing wide, Boiler Makers' convention..... 314
- Fire doors, automatic ..... 331§
- Fire extinguisher, Iland, Johns-Manville.... 1506\*
- Fireman and boiler capacity, The..... 219†
- Fireman, How best to educate the, M. M. convention ..... 1494
- G**
- Gage, Ashton locomotive ..... 1469
- Gage cock, Thomas-Langley..... 367\*
- Gage cock stems, Box tool for refinishing ends of, Tool Foremen's convention.... 477\*
- Gages for sorting oil bolts and nuts, Can. Pac. .... 34\*
- Gardner, Henry, Comparative locomotive shop ratios ..... 38
- Gary, S. L., Dethreading attachment for Lassiter staybolt machines..... 481\*
- Gaskets, Applying rubber ..... 504†
- Gaskets for feed valves, Molding, by E. A. Murray ..... 320\*
- Gaskets, Proper treatment of rubber..... 534†
- Gate, Acme folding tail, Acme Supply Co. ... 324\*
- Gates, Winthrop, Kingan-Ripken valve gear device ..... 60†

General Foremen's Association (see Meetings).....

General Foremen's Association convention.. 527\*

Generator, E. S. B. body-hung axle..... 1393

Generator, U. S. I., body hung..... 1468\*

Georgia Railroad, Pneumatic spring shear and bender..... 596\*

Gerber, J. W., Dismantling of cars..... 306

Gibb Instrument Co., Pyrometer for measuring temperature of steel..... 262\*

Gibbons, J. W., Rules for the safe handling of paints and oils..... 147\*

Gibney, A. J., An office kink..... 607\*

Gillespie, H. C., Babbitting crossheads..... 462\*

Gillespie, H. C., Grinding dry pipe joints..... 425\*

Gillespie, W. J., Patch applied by electric welding..... 660\*

Glass, Edward F., Plunger for holding bar stock..... 589\*

Glass cutter, Gage, by E. A. Murray..... 660\*

Glass, Special, to prevent accident, Hires-Turner Glass Co..... 376

Glenn, Michael, The car inspector and his job (competition)..... 451

Glenn, Sr., M., The M. C. B. book of rules Gutz Co., Ko-Shovel mechanical stoker..... 442\*

Gold Car Heating & Lighting Co., Thermostatic temperature control system..... 264\*

Gould Coupler Co., Automatic slack adjuster for freight cars..... 1265\*

Gould Storage Battery Co., New battery plate..... 1263\*

1392\*

Grain door, Universal, Universal Grain door Co..... 155\*

Grand Trunk, Test of the Young valve and valve gear..... 229\*

Graphite in locomotive valve chambers and cylinders, by M. C. M. Hatch..... 118\*

Grates, Front ends and ash pans, Fuel Association convention..... 282

Gray, Thomas G., Apprentices on the Southern Pacific..... 97

Grease cup, Ratchet, by C. E. Stocker..... 426\*

Great Central of England, Eight wheel locomotive..... 395\*

Great Northern of England, Atlantic type locomotive..... 502\*

Great Northern, Finishing car journal brasses..... 31\*

Great Northern, Taper attachment for turret lathes..... 141\*

Greenfield Tap and Die Corp., The "Gun" tap..... 429\*

Greenlaw Mfg. Co., Steam pressure regulator..... 1313\*

Griest, E. E., Problems of the car department..... 453\*

Grinder, Cylinder head, by J. Lee..... 595\*

Grinder, Dumore portable, Wisconsin Electric Co..... 604\*

Grinding machine (see Machine Tools).

Grinding wheels as applied to locomotive repairs, Tool Foremen's convention..... 477

Grinding wheels, The proper tool for truing Gurney Ball Bearing Co., Ball bearings in lathe construction..... 568†

538\*

**H**

Hammer, Pneumatic post, Q. M. S. Co..... 49\*

Hanger, Drop-forged brake beam, Q. & C. Co..... 1261\*

Hankins, Cyrus, Suggestions for the car designer (competition)..... 456

Hanna Engineering Works, Large pneumatic riveter..... 45\*

Hardening in electric furnaces..... 504†

Hardening with the oxy-acetylene torch..... 643†

Harrington, Joseph, The use of pulverized coal as a fuel..... 399

Harris, H. W., Welding high speed steel to soft steel shanks..... 87\*

Hartough, E. W., Portable cut-off saw..... 636\*

Hartough, E. W., Portable scaffold for car repair tracks..... 237\*

Harvey, H. H., Freight car maintenance, Car Inspectors' convention..... 638

Hatch, M. C. M., Discussion of pulverized fuel, New York Railroad Club..... 116

Hatch, M. C. M., Graphite in locomotive valve chambers and cylinders..... 118\*

Hauk Mfg. Co., Oil burner with preheating arrangement..... 1436\*

Hauser, W. H., Numbering repair parts of cars..... 237\*

Hauser, W. H., Removing air pockets from reservoirs..... 372\*

Hauser, W. H., Straightening press for steel car members..... 526

Headlight, Buda incandescent..... 1441\*

Headlight equipment, Incandescent, Schroeder Headlight Co..... 101\*

Headlight generators, Pyle-National Co..... 1442\*

Headlight bearings..... 611§

Headlight bearings, The I. C. Co..... 629

Headlight law, Tobesura Weno on the..... 614†

Headlight order, The Interstate Commerce Commission..... 1358

Headlights, Incandescent, and headlight laws..... 119

Headlights, Locomotive, M. M. convention..... 1479

Headlinings, The essential requirements and correct treatment of, by H. M. Baxter..... 580

Headlinings, Treatment of light-colored, Painters' convention..... 518

Heating electrically operated trains..... 1471§

Heating, Value of exhaust steam for..... 203†

Heat treated steel? What is..... 273§

Heat treated steel? What is, by Lawford H. Fry..... 335\*

Heat treatment of carbon-steel locomotive axles: water vs. oil quenching, by C. D. Young..... 398\*

Heat treatment of metals, Blacksmiths' convention..... 469

Heat treatment of steel, by George Hutton (competition)..... 418

Heat treatment of steel, Tool Foremen's convention..... 470\*

Heffelfinger, A. E., Leakage of horizontal sheathing..... 276\*†

Heise, William, An apprentice school is necessary..... 255

Helms, J. E., How to develop the car inspector (competition)..... 305

Helms, J. E., The readjusting of yard inspection forces..... 460

Henderson, G. R., Four-wheel trucks for passenger cars, discussion at A. S. M. E..... 28

Henderson, G. R., Operation of radial coupled axles, discussion at A. S. M. E..... 18

Hettenbaugh, R. J., Injector steam pipe roller and expander..... 525\*

Heywood Brothers & Wakefield Co., Double reclining car seat..... 1268\*

Hickman, R. J., Radial drill chuck for locomotive cylinders..... 35\*

Hickman, R. J., Vise chuck for filing piston rings..... 146\*

High-speed steel, Carbon and, Blacksmiths' convention..... 466

Hineman, Walter V., How can I help the apprentice..... 43

Hires-Turner Glass Co., Special glass to prevent accident..... 376

Hobson, W. P., Boiler steel cylinder patch..... 655\*

Hobson, W. P., Manufacturing standard brake levers..... 425\*

Hocking Valley, Gage for steel wheels..... 648\*

Hodges, A. R., The maintenance of the locomotive boiler..... 257

Hoist, Portable air, by E. A. Murray..... 480\*

Hoist, Screw-jack, for handling Mallet locomotives, Whiting Foundry Equipment Co..... 48\*

Holder-on for riveting the boiler barrel to the wrapper sheet, Elgin, Joliet & Eastern..... 249\*

Holder-on for riveting tube sheets to the crown and side sheets, Elgin, Joliet & Eastern..... 250\*

Hopper, F., Clear vision car window..... 603\*

Hose, Metal air brake, Dodge Metal Hose Co..... 1314\*

Hose stripping machine, by R. E. Brown..... 259\*

Houston, Stanwood & Gamble Co., Heavy duty engine lathe..... 666\*

Hunt, W. C., Filing of correspondence, Storekeepers' convention..... 291

Huston, Harold A., Locomotive water and coal consumption..... 69\*

Hutton, George, Heat treatment of steel (competition)..... 418

Hydraulic Press Mfg. Co., Briquetting press for metal borings..... 529\*

Hydraulic Press Mfg. Co., Forcing press..... 374\*

**I**

Illinois Central, Electric furnaces for tempering tools..... 423\*

Imperial Car Cleaner Co., Cushion cleaning machine..... 1394\*

Indicator cards, Clipboard for analyzing, by H. K. Fox..... 504\*

Indicator, locomotive repair, St. Louis & San Francisco..... 98

Industrial Development Corp., Spring nut lock..... 601\*

Ingersoll-Rand Co., Beyer barometric condenser..... 373\*

Ingersoll-Rand Co., Compound-g geared pneumatic drill..... 211\*

Ingersoll-Rand Co. turbo-blower..... 266\*

Ingoldsby, F. S., Steeper end slopes for hopper cars..... 459

Injector steam pipe failures..... 2§

Injector steam pipe roller and expander, by R. J. Hettenbaugh..... 525\*

Injectors, Dimensions for flange and screw couplings for, M. M. convention..... 1455

Inspection, Better locomotive boiler..... 93

Inspection forces, The readjusting of yard, by J. E. Helms..... 460

Inspection of cast iron wheels under freight equipment, by J. P. Yaeger..... 30

Inspection of locomotive spark arresters and ash pans..... 659

Inspection, Regulations for locomotive, by F. A. Whitaker..... 414

Inspection rules, The locomotive, by Frank McManamy..... 175

Inspection system, A locomotive, by N. M. Barker..... 369\*

Inspection, Tobesura Weno on locomotive Inspectors, Dealing with government..... 276\*†

Inspector, I. C. C., More from Tobesura Weno..... 273§

Inspector, The I. C. C., Tobesura Weno..... 442†

Insulation for tank cars, Corkboard, Armstrong Cork Co..... 1393\*

Interchange rules, Discussion of M. C. B., Car Inspectors' and Foremen's convention..... 573

Interchange rules, uniform interpretation of International Oxygen Co., Bipolar oxygen and hydrogen generator..... 550§

International Railroad Master Blacksmiths' Association (see Blacksmiths' Association)

International Railway Fuel Association (see Fuel Association)

International Railway Fuel Assn. (see meetings)

International Railway General Foremen's Association (see General Foremen's Association)

International Railway General Foremen's Assn. (see Meetings)

Interstate Commerce Commission, Headlight hearing..... 629

Interstate Commerce Commission, Report of division of safety..... 83

Iron, Preparing, for malleable castings..... 342†

Iron production, Fig..... 666†

Iron, Weight of wrought..... 412†

**J**

Jack block, Wheel clamp and, Can. Nor..... 22\*

Jack, Geared automatic lowering, Duff..... 1437\*

Jack support for straightening steel car sills, Tool Foremen's convention..... 474\*

Jacks, Liquid for hydraulic..... 157†

Jacks, Power operation of ratchet, by Allen Raymond..... 91\*

Jesson, J. A., Straightening triple valve pistons..... 43\*

Jig for drilling holes in firebox wrapper sheets, Elgin, Joliet & Eastern..... 249\*

Johns-Manville Co., H. W., Boiler wall coating..... 430\*

Johns-Manville Co., H. W., Hand fire extinguisher..... 1506\*

Johns-Manville Co., H. W., A simple steam trap..... 1439\*

Johnston, William, The new apprenticeship..... 256

Jones & Co., Inc., B. M., Piston rod packing for superheated steam..... 1470

Journal box bolts, Device for holding, Tool Foremen's convention..... 474\*

Journal box, Lateral motion, Standard Car Truck Co..... 1268\*

Journal boxes, Method of packing..... 459

Journal boxes on freight cars, Hot..... 385§

Journal boxes on freight cars, Hot (competition)..... 440§

Journal boxes, on freight cars, Hot..... 1280§

Journal boxes, Preventing hot, on the New Haven..... 570

Journal brasses, Finishing car, G. N..... 31\*

Journal brasses, Fitting up..... 581

Journals, Brasses for worn..... 1279§

Journals, Brasses, Tool for reclaiming..... 452\*

Journals, Diameter of driving axle, by L. R. Pomeroy..... 171\*

Journals, Turning car; C. & N. W..... 128\*

Joy, C. U., Care of modern passenger brake equipment, Air Brake convention..... 302

Justus, L. J., Freight car maintenance, Car Inspectors' convention..... 637

**K**

Kelly, C. E., Some points in enginehouse management, (competition)..... 426

Kelly, John P., Air brake maintenance..... 352

Kennecott Co.; Cycloidal weir meter..... 157\*

Kerr, A. B., Why have an apprentice school Keyoke Railway Equipment Co., Murray keyoke..... 651

47\*

Kiesel, W. F., Jr., Operation of radial coupled axles, discussion at A. S. M. E..... 18

Kingan-Ripken valve gear device..... 60†

Kipp, A., President's address at Car Inspectors' convention..... 571

Koelsch & Co., Protecting blue print paper..... 266\*

Kropidowski, V. T., A broad conception of apprenticeship..... 146

Kropidowski, V. T., Fitting driving box brasses..... 360\*

Kropidowski, V. T., Forge shop practice..... 253\*

Kropidowski, V. T., Grinding dry pipes..... 87\*

Kuehner, A. T., A suggestion to officers (apprentice competition)..... 198

**L**

Labor and material, Prices for, M. C. B. convention..... 1301

Lake, A. H., Co-operation in designing cars (competition)..... 460

Lake Superior & Ishpeming, Large Consolidation locomotive..... 343\*

Lamp rating, The A. R. E. E. on..... 1397§

Landis Machine Co., Threading machine for hollow set screws..... 604\*

Landon, W. G., Combined automatic and straight air on French passenger equipment..... 442\*†

Lathe (see Machine Tools)

Lathe tools, tipped with high speed steel, by E. J. McKernan..... 200\*

Le Compte, John V., Grease lubrication of driving boxes..... 388†

Le Compte, John V., Never slight a job..... 142

Le Compte, John V., Piston valve packing rings..... 254

Le Compte, John V., Real efficiency in shop output..... 99

Page numbers under 1,000 refer to *Railway Mechanical Engineer*; those over 1,000 refer to the *Daily Railway Age Gazette*. \*Illustrated article; §editorial; †short non-illustrated article or note; ‡communication.

Le Compte, John V., Toning up an organization .....	95	<b>Locomotives—(Continued)</b>		Magnusson, John A., Bolt extractor.....	1438*
Lee, J., Cylinder head griuder .....	595*	Problems, Present day, by George M. Basford .....	509	Mahr Mfg. Co., Oil burning forge furnaces	1391*
Lee, R. S., Better locomotive boiler inspection .....	94*	Reverse gear, Brown power.....	1441*	Mahr Mfg. Co., Oil rivet forge.....	1438*
Leech, C. C., Carpet stretcher .....	348*	Reverse gear, Power, M. F. Cox, L. & N. ....	602*	Main reservoirs, Removing air pockets from, by W. H. Hauser.....	372*
Leech, C. C., Coach window raiser.....	358*	Reverse gear, Snyder.....	1440*	Maintenance, Air brake.....	1395*
Leech, C. C., Enginehouse organization (competition) .....	469	Riegel .....	339*	Maintenance, The cost of locomotive.....	332*
Leech, C. C., Supporting shafting in concrete buildings .....	40*	Shoes and wedges, fitting up, by W. E. Warner, General Foremen's convention .....	531*	Maintenance, design and operation of electric rolling stock, M. M. convention.....	1490*
Legislation and its effect on business, Railway, Painters' convention .....	519	Slide valve, Superheating .....	1472*	Maintenance of all-steel cars, Life and, by M. K. Barnum .....	129*
Legislation, the situation at Washington.....	612*	Smoke lifter, Q. & C. Co. ....	1442	Maintenance, Units for measuring equipment	1507*
Lemp, W. E., Holding down wheels while changing brasses .....	307*	Spark arresters and ash pans, Inspection of .....	659	Mallet, Anatole, Operation of radial coupled axles .....	15*
Lentz, William L., Teamwork between school and shop .....	255	Superheater, Metallic packing for, M. M. convention .....	1458	Management, A weak spot in shop.....	551*
Letter board splice, Can. Nor.....	128*	Superheater, M. M. convention.....	1483	Mandrel, Expanding for turning locomotive tires, by E. J. Brewster.....	37*
Liberty Mfg. Co., Twin oil strainers.....	1506*	Superheater performance, by S. S. Superheater, T. E. A. convention.....	615	Mandrell, W. F., The work of the car inspector .....	353
Lickey, E. F., Brake beam straightening press .....	195*	Switch, Comparisons of performance.....	1444*	Marsh, E. P., Passenger car cleaning and sanitation, Car Inspectors' convention.....	579
Light, The carbic flare .....	1436	Switching, Superheated steam in.....	332*	Master Blacksmiths' Association (see Blacksmiths' Association)	
Lighting and equipment, Report on train, M. C. B. convention.....	1380*	Tabular comparison of 0-6-0 and 0-8-0 type .....	20	Master Blacksmiths' Association (see Meetings)	
Lighting equipment, Consolidated.....	1390*	Tabular comparison of 2-10-2 and 2-8-0 types .....	235	Master Boiler Makers' Association (see Boiler Makers' Association)	
Lighting fixtures, Clean .....	253	Tabular comparison of 4-8-2, 4-6-2, 4-6-0, 2-6-0 and switching types.....	346	Master Boiler Makers' Association (see Meetings)	
Lighting generator, E. S. B. body-hung.....	1393	Tabular comparison of Mallet and 2-8-2 types .....	236	Master Car and Locomotive Painters' Association of the United States and Canada (see Painters' Association)	
Lighting generator, U. S. L. body hung.....	1468*	Tenders, interior and exterior, Treatment of, Painters' convention.....	518	Master Car and Locomotive Painters' Association (see Meetings)	
Lighting system, Stone-Franklin .....	1267*	Throttle and standpipe arrangement, Baldwin Locomotive Works.....	429*	Master Car Builders' Association (see Meetings)	
Lighting unit, Portable storage battery emergency, Edison .....	1439*	Throttle lever, Differential, D. L. & W. 4-6-2 type .....	6*	Master Car Builders' Association, Election of officers .....	1419
Linn, John H., Preparedness—The human element .....	449	Throttle, Woodard, American Locomotive Co. ....	48*	Master Car Builders' Association, Loading rules .....	1376*
Liquid for hydraulic jacks .....	157†	Tools, Caring for, by John F. Long. Triplex articulated .....	385*	Master Car Builders' Association, Proceedings .....	1283*, 1359*, 1399*
Lister, F. G., Systematic repairs to freight equipment .....	248	Types, and road conditions.....	113*	Master Car Builders' Association, Prices for labor and material .....	1301
Loading rules, M. C. B. convention.....	1376*	Types of, ordered.....	1471*	Master Car Builders' Association, Report on brakes and air signals .....	1290*
Loading rules, The use of the M. C. B.....	1395*	Locomotive inspection rules, The, by Frank McManamy .....	175	Master Car Builders' Association, Report on brake shoe and brake beam equipment.....	1293*
Lock, Box car door, Triple Lock Co.....	540*	Locomotive inspection system, by N. M. Barker .....	369*	Master Car Builders' Association, Report on car construction .....	1379
<b>Locomotives</b>		Locomotive maintenance and fuel economy, by A. N. Willis, Fuel convention .....	281	Master Car Builders' Association, Report on car trucks .....	1380
2-8-0 D. & H. pulverized fuel.....	1384*	Locomotive Painters' Association, Car and (see Painters' Association)	273*	Master Car Builders' Association, Report on car wheels .....	1359*
2-8-0, A high capacity.....	1425*	Locomotive repair facilities and costs.....	532	Master Car Builders' Association, Report on couplers .....	1364*
2-8-0 Lake Superior & Ishpeming.....	343*	Locomotive repairs, Classification of, General Foremen's convention.....	536*	Master Car Builders' Association, Report on draft gear .....	1371*
2-10-2, Erie Railroad .....	223*	Loss and damage to freight .....	549*	Master Car Builders' Association, Report on settlement prices for reinforced wooden cars .....	1302
2-10-2, New York, Ontario & Western.....	223*	Louisville & Nashville, Holding down wheels while changing brasses .....	307*	Master Car Builders' Association, Report on standards and recommended practice.....	1286*
4-4-0 British .....	395*	Louisville & Nashville, Locomotive power reverse gear .....	602*	Master Car Builders' Association, Report on train lighting .....	1380*
4-4-2 type, Great Northern of England .....	502*	Lubricants, Test of .....	148†	Master Car Builders' Association, Revision of rules of interchange report.....	1296*
4-6-2, D. L. & W. ....	4*	Lubricants, Viscosity of .....	147†	Master Car Builders' Association, Safety appliance report .....	1375
4-6-2, R. F. & P. ....	4*	Lubrication, The cost of .....	1472*	Master Car Builders' Association, Specifications and tests of materials, committee report .....	1411*
2-8-8-0 type, Baltimore & Ohio.....	389*	Lubrication of driving boxes, Grease, by John V. Le Compte .....	388†	Master Car Builders' Association, Tank car report .....	1399*
Axle failure .....	650	Lubrication of locomotive driving boxes, Grease, by George J. Burns .....	234	Master Car Builders' Association, Welding of cast-steel truck side frames and bolsters .....	1417
Axles, Operation of radial coupled, A. S. M. E. ....	15*	Lubricator, Graphic cylinder, E. H. Sweeley .....	104*	Master Mechanics' Association, Alloy steel in locomotive design, by L. R. Pomeroy.....	1499*
Boiler efficiency .....	440*	Lubricator for locomotive air pumps.....	210*	Master Mechanics' Association, Apprenticeship on railroads, by F. W. Thomas.....	1509
Boiler efficiency, by J. T. Anthony.....	443*	Lumber, Storekeepers' convention.....	295	Master Mechanics' Association, Co-operation with other associations .....	1493*
Boiler, The maintenance of, by A. R. Hodges .....	257	Lynn, Samuel, The life of a steel freight car .....	29	Master Mechanics' Association, Dimensions for flange and screw couplings for injectors .....	1455
Brake system, Moisture in, by Mark Purcell, Air Brake convention.....	303	<b>M</b>		Master Mechanics' Association, Design and maintenance of locomotive boilers.....	1480
British express, by E. C. Poultney.....	552*	MacBain, D. R., Address at Boiler Makers' convention .....	311	Master Mechanics' Association, Design and materials for pistons, valves, rings and bushings .....	1496*
British goods, Modern, by E. C. Poultney .....	621*	MacBain, D. R., Boiler expansion experiments .....	496*	Master Mechanics' Association, Design, maintenance and operation of electric rolling stock .....	1490*
Cab window, Clear vision, F. Hopper.....	603*	MacBain, D. R., President's address, M. C. B. convention.....	1283	Master Mechanics' Association, Election of officers .....	1527
Capacity, Increased .....	58*	MacCorkindale, A., Better locomotive boiler inspection .....	94*	Master Mechanics' Association, Equalization of long locomotives.....	1488*
Cleaning of .....	273*	McAuliffe, Eugene, Functions of a railroad fuel inspector, Fuel convention.....	286	Master Mechanics' Association, Fuel economy and smoke prevention.....	1475*
Coal and water consumption, by Harold A. Huston .....	69*	McConway & Torley Co., Passenger car uncoupling rigging .....	1266	Master Mechanics' Association, Locomotive headlights .....	1479
Counterbalances, by W. E. Warner, General Foremen's convention.....	528*	McCoy, George E., Water coolers for passenger cars .....	460*	Master Mechanics' Association, Metallic packing for superheater locomotives.....	1458
Coupler pocket, Adjustable, American Steel Foundries .....	1312*	McManamy, Frank, Address at Boiler Makers' convention .....	317	Master Mechanics' Association, Modernizing of existing locomotives.....	1519*
Crank pins, Design of hollow, by C. W. Benica .....	66*	McManamy, Frank, Address at General Foremen's convention .....	527	Master Mechanics' Association, Proceeding .....	1447*, 1475*, 1511*
Designing to suit conditions.....	1443*	McManamy, Frank, Address at T. E. A. convention .....	564	Master Mechanics' Association, Report of committee on subjects .....	1527
Driving box (see Driving Box)		McManamy, Frank, The locomotive inspection rules .....	175	Master Mechanics' Association, Report on mechanical stokers .....	1451
Electric, Chattering wheel slip in, by G. M. Eaton .....	178*	McQuay, Norris Mfg. Co., Closed joint piston rings .....	1437*	Master Mechanics' Association, Revision of standards and recommended practice.....	1454*
Electric, Design, maintenance and operation of, M. M. convention.....	1490*	<b>Machine Tools</b>		Master Mechanics' Association, Specifications and tests of materials.....	1514*
Electric, Mechanical design of, by A. F. Batchelder .....	558	Boring bar for cylinder and valve chamber bushings, E. J. Rooksby & Co. ....	208*		
Equalization of long, M. M. convention .....	1488*	Drilling and tapping machine, Portable, Wiener Machine Co. ....	262*		
Equipment for burning pulverized fuel .....	115*	Grinding machine; Modern Tool Co. ....	374*		
Exhaust nozzles, Road tests of, by E. S. Barnum .....	67*	Keysat milling and cottering machine, Newton .....	427*		
Exhaust pipe seats, Extension, on Union Pacific .....	525	Lathe for tool room service, Davis.....	1470*		
Express in France.....	231*	Lathe, Heavy duty engine, Houston, Stanwood & Gamble Co. ....	666*		
Frame, Cast steel rear unit, R. F. & P. 4-6-2 type.....	9*	Milling machine, Vertical, Newton.....	47*		
Front end design.....	1444*	Sawing machine, Cold metal; Vulcan Engineering Sales Co. ....	376*		
Front ends, altering locomotive.....	220*	Selection of, by G. W. Armstrong.....	89*		
Front ends, grates and ash pans, Fuel Association convention .....	282	Threading machine for hollow set screws, Landis Machine Co. ....	604*		
Garratt type, for Brazil.....	448*	Machine tool equipment, Adequate.....	1443*		
Getting the most out of .....	221*				
Headlights, M. M. convention.....	1479				
High capacity and low axle weight.....	386*				
Impact tests, by C. B. Young.....	288*				
Improvements and the stockholders.....	1471*				
Improving the American .....	1444*				
Journals, Diameter of driving axle, by L. R. Pomeroy.....	171*				
Journals, Machining .....	611*				
Maintenance, The cost of .....	332*				
Mallet, Intercepting valve for.....	263*				
Modernizing of existing, M. M. convention .....	1519*				
Operating conditions, Do yours suit? .....	385*				
Operation, Increasing length of runs.....	111*				
Orders in 1916.....	1423*				
Piping and jackets, by M. J. Cairus.....	420*				

Master Mechanics' Association, Standardization of screw threads..... 1456\*

Master Mechanics' Association, Superheater locomotives ..... 1483

Master Mechanics' Association, Train resistance and tonnage rating..... 1523\*

Master Mechanics' Association, Use of powdered fuel in locomotives..... 1511

Material, The cost of..... 1247‡

Material delivery at the Macon shops, by G. W. Alexander ..... 359

Material, Periodical appropriations for..... 167‡

Material, Prices for labor and, M. C. B. convention ..... 1301

Materials, Design and, for pistons, valves, rings and bushings, M. M. convention..... 1496\*

Materials, Specifications and tests of, M. M. convention ..... 1514\*

M. C. B. billing and repair cards, Car Inspectors' convention ..... 643

Mechanical department clerk, The..... 222‡

Mechanical department clerk, The..... 276‡

Mechanical department clerk, The..... 1509‡

Mechanical department, College men in the Mechanical department, College men in the, by George S. Clouser..... 334‡

Mechanical department costs..... 1507‡

Mechanical Specialty Co., The La Rock pipe wrench ..... 431\*

**Meetings**

Air Brake Association..... 159, 668

American Railroad Master Tinner's, Coppersmiths' and Pipefitters' Association..... 213, 268, 379

American Railway Tool Foremen's Association..... 268, 378, 433

American Society of Mechanical Engineers, The ..... 51, 542

American Society for Testing Materials Association of Manufacturers of Chilled Car Wheels ..... 606

Atlantic City Exhibits ..... 52

Car Foremen's Association of Chicago..... 606

Car Foremen's Association..... 326, 378, 486

Central Railway Club..... 159, 214

Chief Interchange Car Inspector's and General Foremen's Association..... 51

International Railway General Foremen's Association..... 213, 268, 378, 433

Master Blacksmiths' Association..... 213, 389, 433

Master Boiler Makers' Association..... 51, 268

Master Car & Locomotive Painters' Association..... 213, 379, 433, 486

M. C. B. and M. M. conventions, 326, 668, 669

Railway Fuel Associations..... 106

Railroad Section, American Society of Mechanical Engineers ..... 606

Railway Storekeepers' Association..... 213

Smoke Prevention Association..... 606

The Traveling Engineers' Association, 326, 378, 433, 486, 542

Western Railway Club ..... 51

Meetings, Efficiency, for toning up an organization, by J. A. Pack..... 95

Mellin, C. J., Operation of radial coupled axles, discussion at A. S. M. E..... 18

Men, Better, needed in the car department..... 1397

Men, College, in the mechanical department..... 1509‡

Men, Relation of foremen to, by T. E. Freeman, General Foremen's convention..... 533

Men, The selection of, by John H. Linn..... 449

Men, The training of..... 1443‡

Men, training young, for promotion, by F. W. Thomas ..... 597

Merriman, Arthur J., Don't scold..... 255

Metallic packing for saturated steam locomotives, Molding ..... 264\*

Metallic packing for superheater locomotives, M. M. convention..... 1458

Metallic packing, Specialists on, in the roundhouse ..... 536

Metal, Self Lubricating..... 648‡

Metals, Chart for determining the expansion of, by W. F. Schapborst..... 504\*

Meter, Boiler; Bailey Meter Co..... 375\*

Meter, Compressed air, New Jersey Meter Co..... 428\*

Meter, Cycloidal weir, Kennicott Co..... 157\*

Meter, A steam flow, Bailey Meter Co..... 323\*

Methods for railway shops, Standard..... 493‡

Microscope and boiler steel, The..... 494‡

Miller, R. N., Buffing stresses in box cars..... 409\*

Miller, Robert N., A double thermit weld..... 237\*

Miller, R. N., Terminal car cleaning yards (competition) ..... 357

Milling cutters with inserted piece, Tool Foremen's convention ..... 478\*

Milling machine (see Machine Tools)

Milner, B. B., Discussion of superheater performance ..... 340

Missouri, Kansas & Texas, Portable cut-off saw ..... 636\*

Missouri, Kansas & Texas, Portable scaffold for car repair tracks..... 237\*

Missouri, Kansas & Texas, Pulverized fuel for stationary boilers..... 499\*

Missouri Pacific, Water treatment on..... 393\*

Modern Tool Co., Grinding machine..... 374\*

Moment of inertia of rectangles, Tables for determining the, by C. H. Faris..... 184

Mooney, Will C., Jr., Apprenticeship in the drawing room ..... 276‡

Motor, Induction, for turntables and transfer tables, Westinghouse..... 373\*

Motors, Anti-friction bearings for shop..... 142

Motors, Heavy duty, for direct current, Reliance ..... 1437\*

Mounce, R. S., Laying out eccentric keyways ..... 92\*

Mudge & Co., Dining car blower ventilator ..... 1265\*

Mud-ring, The, and the cracking of side sheets, Boiler Makers' convention..... 317

Muhlfield, J. E., Pulverized fuel for locomotives ..... 114\*

Murdock, John C., Piston valve packing rings ..... 88

Murdock, John C., What can be done for the apprentice ..... 259

Murray, E. A., Boiler washer's hose cart... 260\*

Murray, E. A., Chuck for the manufacture of flue cutter blades..... 88\*

Murray, E. A., Eccentric keyway cutter... 596\*

Murray, E. A., Gage glass cutter..... 660\*

Murray, E. A., Molding gaskets for feed valves ..... 320\*

Murray, E. A., Pipe bending machine..... 321\*

Murray, E. A., Pneumatic riveting machine ..... 656\*

Murray, E. A., Portable air hoist..... 480\*

Murray, E. A., Portable tire heater..... 258\*

**N**

Nagle, John H., Rack for storing smoke box front ends..... 651\*

Name, Our change in..... 1‡

Nashville, Chattanooga & St. Louis, Steel frame single sheathed caboose..... 511\*

National Brake Co., Geared hand brake for blind end cars..... 1314\*

National Lock Washer Co., Spring plug curtain roller ..... 1261\*

National Refrigerator Car Co., Chicago, Automatic refrigerator and heater car... 662\*

Nell, S. E., How to develop the car inspector (competition) ..... 305

New Jersey Meter Co., Compressed air meter ..... 428\*

Newton Machine Tool Wks., Inc., Duplex keyseat milling and cottering machine... 427\*

Newton Machine Tool Wks., Inc., Vertical milling machine ..... 47\*

New York Central, Boiler expansion experiments ..... 496\*

New York Central, Power operation of ratchet jacks ..... 91\*

New York Central, West, Brake beam straightening press ..... 195\*

New York, New Haven & Hartford, Preventing hot boxes on the..... 570

New York, Ontario & Western, 2-10-2 type locomotive ..... 223\*

Norfolk and Western electrifications..... 121\*

Norfolk & Western, Service of 90-ton cars. 194

Northern Pacific, Express refrigerator cars. 243\*

Nut lock, Spring, Industrial Development Corp. .... 601\*

Nystrom, K. F., Comparison of all steel and composite coach construction..... 191\*

**O**

Oatley, H. B., Discussion of superheater performance ..... 341

Officers, attention! Higher ..... 549‡

Officers, Selection of: Are you guilty?..... 1508‡

Officers, Selection of future..... 550‡

Officers, The successful..... 440‡

Officers, A suggestion to, on apprenticeship, by A. T. Kuehner ..... 198

Oil cans of rational design, St. Louis & San Francisco ..... 91\*

Oil installation for small shops, Fuel..... 590\*

Oil, Light machine..... 660‡

Oil, Saving, and wasting fuel..... 331‡

Oil strainers, Twin, Liberty Mfg. Co..... 1506\*

Oiling the interior of steel hopper cars, Painting or, Painters' convention..... 523

Oils, Acidity of lubricating..... 560‡

Oilstones, Truing ..... 49‡

Oliver Iron & Steel Co., Coupler centering device ..... 1267\*

O'Malley-Bear Valve Co., Multiplate valve ..... 153\*

Oplinger, H. E., Portable kerosene vaporizer ..... 43\*

Oplinger, H. E., Steam gage testing stand. Orders for locomotives in 1916..... 310\*

Organization and low maintenance costs..... 1423‡

Organization, Efficient enginehouse, by E. W. Smith ..... 112‡

Organization, Toning up an..... 143\*

Organization, Toning up an..... 57‡

Output, Increasing shop, by H. D. Wolcomb ..... 99

Output, Real efficiency in shop..... 589

Overdoing things, The danger of, by Harvey De Witt Wolcomb ..... 73

Oxy-acetylene and electric welding, Blacksmiths' convention ..... 469

Oxy-acetylene, Cutting off staybolt ends with, Boiler Makers' convention ..... 315

Oxy-acetylene cylinder weld, by M. C. Whelan ..... 388‡

Oxy-acetylene process in boiler repairs, Boiler Makers' convention..... 311

Oxy-acetylene, A record, cylinder weld..... 199\*

Oxy-acetylene torch, Hardening with the..... 643‡

Oxy-acetylene welding in boiler repairs..... 649\*

Oxygen and hydrogen generator, Bipolar, International Oxygen Co..... 45\*

Oxygen tests ..... 211‡

**P**

Packing cone rings, Grinding rod, by W. W. Effe ..... 310\*

Packing for superheated steam, Jones piston rod ..... 1470

Packing, Metallic, for superheater locomotives, M. M. convention..... 1458

Packing, Metallic, Specialists on, in the roundhouse ..... 536

Packing, Molding metallic, for saturated steam engines ..... 264\*

Packing ring, Closed joint cylinder, McQuay, Norris Mfg. Co..... 1437\*

Packing rings, Design and materials for cylinder and valve, M. M. convention..... 1496\*

Packing rings, Piston valve, by John V. Le Compte ..... 254

Pack, J. A., Efficiency meetings for toning up an organization ..... 95

Paint, Effects of water and oil cleaning methods on, Painters' convention..... 512

Paint, The purchase of, on railroad specifications, Painters' convention ..... 520\*

Paint, The purchase of, on specifications... 494‡

Paint, Varnish remover for removing, Painters' convention ..... 523

Paints and oils, Rules for the safe handling of, by J. W. Gibbons..... 147\*

Painters' Association convention, Master Car and Locomotive ..... 515\*

Painters' convention test committee report.. 515

Painting of steel freight cars..... 275‡

Painting or oiling the interior of steel hopper cars, Painters' convention ..... 523

Painting to preserve the life of steel cars, by H. M. Clarence ..... 408

Pamplin, W. J., and S. C. Morton, Improved drop pit ..... 154\*

Park, A., Analyzing engine failures (competition) ..... 366

Patram, B. F., Car department apprentices, first prize, Car Inspectors' Association competition ..... 579

Patterson, W. E., How to develop the car inspector (competition) ..... 305

Payson, George S., A correction..... 276‡

Peat, Pulverized, for Swedish locomotives. 120‡

Pennington, M. E., Refrigerating freight in transit ..... 585\*

Pennsylvania Railroad, Building steel box cars ..... 193\*

Pennsylvania Railroad, Foreign car repair and billing ..... 185\*

Pennsylvania Railroad, 70-ton Gondola cars. 406

Performance, Comparisons of switch engine. 1444‡

**Personals—General**

Anders, R. E..... 52

Ayerson, A. R..... 542\*

Barrett, C. D..... 327

Biugaman, C. A..... 160

Borell, E. A..... 214

Burgman, C. P..... 106

Cameron, H. D..... 269, 327

Campbell, P. A..... 379

Conniff, P. H..... 52, 160, 214\*

Cooper, J. A..... 487

Cunningham, Dan G..... 434\*

Dickson, J..... 379\*

Durham, George ..... 543\*

Fitzmorris, James ..... 379

Flanigan, M. J..... 670

Gaines, F. F..... 106

Jackson, R. E..... 542

Jefferson, M..... 269

Jones, L. B..... 327

Kelly, William ..... 607

Kuehner, A. T..... 269

Lewis, Thomas ..... 269, 327

Lister, F. G..... 160

Macbeth, H. A..... 542

MacRae, J. A..... 106

McCarthy, M. J..... 487

McNeill, J. J..... 52

O'Neill, W. J..... 269

Malone, W. H..... 487, 542

Maxfield, H. H..... 269, 327\*

May, H. C..... 52, 106

Pearce, E. S..... 269

Pfahler, E. P..... 269

Pyne, R. A..... 542

Randolph, V. B..... 487

Reid, H. G..... 670

Risque, J. P..... 214\*

Sedwick, T. D..... 160

Silcox, L. K..... 269

Sumner, Elliott ..... 379, 434\*

Taylor, F. W..... 670

Vagar, A. J..... 434

Warner, C. W..... 487

Warthen, H. J..... 215\*

Williams, A. G..... 379

Wilson, F. W..... 434

Wood, P. O..... 487, 543

**Personals—Master Mechanics and Road Foremen of Engines**

Adams, A. C..... 160

Attridge, O. H..... 379

Baldwin, A. R..... 487\*

Basiner, J. A..... 543

Bauer, Frank J..... 379

Bennett, Robert G..... 328

Benson, J. C..... 380

Bettenburg, N. C..... 607\*

Birse, John ..... 670

Blue, B. W..... 543

Bluetge, Joseph ..... 52

Brown, A..... 215, 328

Brummel, J. L..... 215

Butler, F. A..... 670

Butler, J..... 269

Page numbers under 1,000 refer to *Railway Mechanical Engineer*; those over 1,000 refer to the *Daily Railway Age Gazette*. \*Illustrated article; ‡editorial; †short non-illustrated article or note; ‡communication.

Personals—Master Mechanics and Road Foremen of Engines—(Continued)

Chaffee, W. D. 543
Charles, M. G. 328
Clewley, H. 434, 487
Coe, T. W. 215
Cooper, F. S. 269
Corbett, B. 52
Culbreth, Oscar 269
Cuyler, G. W. 487, 543
Dales, A. E. 607
Davis, Bertron H. 607
Dowling, J. J. 487
Drake, I. H. 269\*
Drescher, P. L. 106
Duffey, G. J. 106
Dunkerley, W. E. 215
Eidson, B. B. 607\*
Elmore, William R. 487, 215
Embury, W. B. 52
English, H. A. 434
Extrand, Charles W. 607, 215
Farr, B. J. 269
Fitzgerald, W. T. 607
Flavin, J. T. 543
Fryburg, F. M. 487, 269
Galloway, A. K. 380
Galloway, G. K. 215
Gaston, J. H. 270
Gemlo, Wm. 487
Gethens, J. T. 380
Greenwood, H. E. 106
Gribbin, C. 106
Halliday, J. B. 328
Hambly, T. 380
Hamilton, T. H. 106
Hamilton, Walter 328
Hankins, Frederick W. 106
Hanna, I. H. 160
Harris, E. J. 487
Harris, W. F. 487
Hawkins, J. 215
Haylor, R. 52
Hedge, G. H. 434
Heiser, William F. 106
Howley, T. F. 670
Hussey, F. A. 215
Hyde, R. C. 487
Ingram, W. N. 487
Ironsides, A. J. 160
Johnson, B. P. 434
Keller, W. H. 607\*
Kendall, A. H. 107
Kendrick, J. P. 328
Kerwin, J. M. 670
Leat, Charles 328
Long, W. H. 215
McCarra, M. F. 487
McCarthy, T. W. 487
McOade, R. J. 434
Meeder, William R. 215, 269\*
Moshisky, P. C. 434
Mullen, John F. 487, 543
Norton, C. H. 52
Nowell, G. H. 215
Peers, A. 328
Phelan, T. F. 328
Porter, Charles D. 487
Quigley, J. E. 607
Raycroft, T. I. 107
Reagan, Frank H. 434
Reid, H. G. 328
Renix, W. J. 215
Roberts, A. J. 328
Sadtler, F. W. 380
Schule, Robert 107
Searle, J. D. 107
Shull, G. F. 160
Smith, G. F. 487, 160
Smith, Jr., John L. 670
Smith, M. R. 543
Smith, William B. 434
Snell, E. J. 434
Standiford, A. W. 434
St. Clair, D. W. 215
Stow, J. P. 107
Strang, W. H. 52
Tenney, J. W. 487
Twist, G. 328, 487
Wallace, F. C. 380
Weber, George W. 543
West, A. 434, 487, 215
West, S. 543
Wiechert, W. T. 107\*
Windle, Thomas 215
Wintersteen, John 52
Wylar, J. B. 434
Yonkers, F. J. 670

Personals—Car Department—(Continued)

McMath, C. N. 328
Mills, W. 215
Munro, C. A. 215, 434
Neary, John 107
Opie, E. 270
Ord, L. C. 53
Orman, W. H. 543
Pierce, H. E. 270
Porteous, James 670
Redmond, T. 107
Reid, H. 435
Rudd, J. 380
Saunders, H. 270
Schroeder, John H. 487
Silverwood, W. 435
Siverton, P. J. 543
Stillwell, W. S. 435
Watters, R. J. 380
Wheaton, C. 380
White, H. J. 270
Wilson, G. W. 435
Woodcock, B. 215

Personals—Shop and Enginehouse

Amy, H. A. 543
Armstrong, G. W. 215
Barber, W. J. 328
Beatt, P. S. 215
Behan, F. W. 435
Bennett, H. E. 270
Reyer, Jr., O. S. 53
Black, J. 107
Blackwell, C. S. 488
Boardman, C. 53
Brennan, E. J. 53
Canfield, G. 380
Cardell, M. A. 53, 380
Carlisle, P. 53
Carroll, F. 53
Clark, A. W. 215
Clissold, G. 215
Coleman, D. D. 488
Cook, W. 543
Corbett, N. B. 328
Cromwell, E. G. 270
Davis, A. J. 488
Dickson, R. S. 543
Doctor, C. T. 107
Dodd, J. 435
Du Pue, E. T. 488
Duncanson, J. N. 215
Edwards, A. 380
Finegan, L. 53
Fournier, A. 53
Gibson, G. C. 328
Granger, L. M. 488
Grant, O. C. 53
Gruys, William 488
Hannah, A. T. 380
Harrington, H. H. 488
Harris, E. J. 435
Hearts, G. C. 435
Herlick, H. 215
Hillman, H. A. 488
Hinerman, C. W. 543
Honan, J. 270
Houghton, Edward F. 435
Huckins, H. C. 488
Huey, R. A. 328
Illingsworth, S. 488
Irwin, J. B. 380
Jackson, J. W. 329
Kraft, H. B. 107
Langton, G. H. 160
Larson, L. B. 53
Lozo, F. J. 270
Lukes, H. N. 53
McGown, Jr., James. 329
McLean, N. 380
McPherson, R. A. 329
Mallison, A. 543
Martin, A. W. 329
Mays, A. 107
Medland, James 435
Mueller, S. E. 329
Millice, R. N. 215
Mills, E. R. 215
Moulton, C. H. 215
Muir, J. D. 329
Murphy, E. J. 53
Newmarch, J. C. 53
Patterson, B. T. 216
Pentland, A. J. 329
Perry, C. A. 329
Pettit, E. A. 216
Piper, A. R. 488
Pirie, A. G. 380
Poole, E. P. 488
Pratt, G. 329
Quinn, R. 329
Reid, J. A. 329
Rogers, John D. 670
Ryan, T. 53
Ryan, T. T. 488
Scott, M. F. 488
Shenbrot, W. 216
Smallwood, W. F. 216
Smith, D. E. 435
Summerville, R. 543
Swindell, John R. 329
Taslor, A. 107
Thompson, J. H. 53
Tolking, F. J. 544
Tracy, S. L. 107
Tracy, William J. 671
Tregaskis, J. 435

Personals—Shop and Enginehouse—(Continued)

Twist, G. 216
Vincent, S. 380
Walker, H. 270
Warner, F. D. 329
Warner, H. E. 216
Waterman, O. C. H. 544
Webb, J. 107
Wenzel, J. J. 216
Wheeler, C. A. 488
Williams, F. 380
Willis, F. L. 329
Wilson, J. H. 107
Wortman, W. H. 216
Wright, W. 380
Young, T. 107

Personals—Purchasing and Storekeeping

Adams, R. H. 435
Akin, H. B. 544
Alexander, E. J. 53
Bankson, C. L. 53
Brown, A. S. 53
Castle, W. F. 488
Caye, G. W. 107\*
Clapp, C. D. 671
Clark, H. A. 380
Conway, G. W. 160
Cotton, G. E. 435
Culver, W. R. 671
Downing, W. E. 380
Ferguson, J. D. 107
Greenfield, Hugh 544
Harrison, I. P. 671
Harsh, I. H. 270
Humphrys, E. 53
Ingold, G. T. 435
McCaughan, J. C. 435
McOade, H. J. 380\*
McQuilkin, O. V. 435
Meyers, E. 160
Motz, G. E. 107
Murphy, F. A. 380
Myers, E. W. 160
O'Connor, Francis I. 544\*
O'Fallon, William G. 435
Paul, E. A. 380
Porter, N. V. 544
Pratt, I. F. 544
Russell, George K. 488
Saye, Samuel Wilson. 329
Shanks, H. T. 671
Shea, P. J. 380
Shoemaker, H. 488
Souter, T. N. 607
Span, Harry P. 270
Spiers, H. A. 380
Sutton, C. G. 380
Thomas, Isaac B. 380, 435
Thornley, E. W. 380
Townner, M. E. 160\*
Underwood, R. L. 671
Williams, G. F. 488
Wood, O. H. 544
Woods, R. O. 329

Personals—Obituary

Angell, William Arnold. 671
Bundy, C. L. 435
Busse, F. W. 160
Clough, Colonel William P. 488
Conner, S. G. 160
Cota, A. J. 435
Crew, R. H. 107
Elliott, W. H. 216
Ely, Theodore N. 607, 671\*
Gallagher, G. A. 216
Hancock, G. A. 160
Hayes, William C. 53
Hennessey, Thomas J. 53
Hutchinson, Thomas J. 435
Kirby, John 53
Lewis, H. L. 160
Lewis, Thomas E. 435
McWood, William 607\*
Pond, R. D. 544
Roberts, C. F. 216
Shields, A. 160
Stewart, R. L. 216
Thomas, W. A. 544
Turner, C. G. 160
Walsh, J. F. 270
White, Fred H. 435
Wratten, William 488
Petermann, R. P., Reclaiming driving boxes 206\*
Piece work, Blacksmiths' convention. 468
Piece work, Storekeepers' convention. 290
Pier, Improvements on the. 1247‡
Pipe bending machine, by E. A. Murray. 321\*
Pipe connection, Flexible, McLaughlin. 49\*
Pipe, Increase in production of steel. 604†
Pipe material. 459†
Pipe union, Stavlock, Standard Union Co. 103\*
Pipes for reciprocating engines, Size of steam. 568†
Piping, Advantages of high-velocity steam. 524†
Piston rings, Vise chuck for filing. 146\*
Piston rod packing for superheated steam, Jones. 1470
Piston valve (see Valve).
Pistons, Design and materials for, M. M. convention. 1496\*
Pittsburgh & Lake Erie, Patch applied by electric welding. 660\*
Pittsburgh Locomotive Power Reverse Gear Co., Snyder reverse gear. 1440\*

Page numbers under 1,000 refer to Railway Mechanical Engineer; those over 1,000 refer to the Daily Railway Age Gazette. \*Illustrated article; †editorial; ‡short non-illustrated article or note; †communication.

Philadelphia & Reading, Gage for checking the location of wheels on the axle..... 514\*

Philadelphia & Reading, Repairing angle cocks ..... 309\*

Philadelphia & Reading, Testing pneumatic tools ..... 413\*

Phoenix Manufacturing Co., Turret toolpost for engine lathes..... 1439\*

Planer clamps, Quick adjustment, by Robert W. Rogers ..... 44\*

Pneumatic clamping and holding-on devices, by Frank J. Borer..... 655\*

Pneumatic hammers, Lubricating tank for, Tool Foremen's convention..... 477\*

Pneumatic riveting machine, by E. A. Murray ..... 656\*

Pneumatic tools, Holder-on for, Tool Foremen's convention ..... 474\*

Pneumatic tools, Testing, by J. D. Smith... 413\*

Pollard, Nielsen, The right age to start apprenticeship is 18..... 255

Pomeroy, L. R., Alloy steel in locomotive design, M. M. convention..... 1499\*

Pomeroy, L. R., Diameter of driving axle journals ..... 171\*

Pomeroy, L. R., Four-wheel truck for passenger cars, discussion at A. S. M. E..... 28

Poultney, E. C., British express locomotives Poultney, E. C., Modern British goods locomotives ..... 552\*

621\*

279

618

Power, Assignment of, T. E. A. convention

Power, Costkeeping for railroad shop, M. M. convention ..... 1494\*

Power costs, Shop..... 1507\*

Pratt & Lambert, Inc., An enamel coach finish ..... 1313

Pratt, E. W., President's address, M. M. convention ..... 1444\*

Pratt, E. W., President's address, M. M. convention ..... 1447

Preparedness and the railways..... 620

Preparedness—The human element, by John H. Lion ..... 449

Press, Brake beam straightening, by E. F. Lickey ..... 195\*

Press for metal borings, Briquetting, Hydraulic Press Mfg. Co..... 539\*

Press for steel car members, Straightening, by W. H. Hauser..... 526

Press, Hydraulic forcing, Hydraulic Press Mfg. Co..... 374\*

Preston, R. L., Driving box repairs..... 100\*

Price, Towson, Water readings in locomotive tests ..... 126\*

Promotion: Are you guilty?..... 1508‡

Promotion of men, Systematic..... 2‡

Promotion, A question of, by Gulf..... 450

Promotion, The question of, by F. A. Whitaker ..... 74

Promotion, Training young men for, by F. W. Thomas..... 597

Promotions in the mechanical department... 612‡

Pryor, Carl J., Four suggestions from an apprentice ..... 256

Pulleys, Removing ..... 459†

Pulverized coal in engine service, by C. W. Corning ..... 565\*

Pulverized fuel for locomotives..... 1508‡

Pulverized fuel, Use of, in locomotives, M. M. convention ..... 1511

Pump for testing boilers..... 499\*

147

Pumps, Oil, with quick return stroke, Bowers ..... 1390

Punch and riveter, Pneumatic, Vulcan Engineering Sales Co..... 265\*

Punch press for making washers, Southwark Foundry & Machine Co..... 601\*

Purcell, Mark, Moisture in locomotive brake system, Air Brake convention..... 303

Pyle-National Co., Headlight generator..... 1442\*

Pyrometer for measuring temperature of steer, Gibb Instrument Co..... 262\*

Q

Q & C Co., Drop-forged brake beam hanger. 1261\*

Q & C Co., Smoke lifter for locomotives... 1442

Q. M. S. Co., Post hammer..... 49\*

Quigley Furnace Specialties Co., Fire brick cement ..... 1506

R

Rack for storing smoke box front ends, by John H. Nagle..... 651\*

Radial drill chuck for locomotive cylinders, by R. J. Hickman..... 35\*

Radial stay, Notes on the button-head, by Joseph Smith ..... 96\*

Radiators, Tests of passenger car, by Prof. A. J. Wood, M. M. convention..... 1459\*

Railroad clubs falling down..... 439‡

Rail saw, A reclaimed, by E. T. Spidy..... 359\*

Railway Electrical Engineers' Association convention ..... 1398

Railway Fuel Association (see Meetings).

Railway Fuel Association (see Fuel Association).

Railway General Foremen's Association (see General Foremen's Association).

Railway Master Mechanics' Association (see Master Mechanics' Association).

Railway Storekeepers' Association (see Meetings).

Railway Storekeepers' Association (see Storekeepers' Association).

Railway Supply & Equipment Co., Rocker draft gear ..... 1310\*

1251\*

Railway Supply Manufacturers' Association exhibit ..... 1270

Railway Tool Foremen's Association (see Tool Foremen's Association).

Ratios, Comparative locomotive shop, by Henry Gardner ..... 38

Raymond, Allen, Power operation of ratchet jacks ..... 91\*

Reading Specialties Co., Car replacers..... 1469\*

Reclamation of bolts and nuts, Efficient, by E. T. Spidy ..... 33\*

Reclamation of human scrap, by Harvey De Witt Wolcomb ..... 169

Reclamation of material, Tool Foremen's convention ..... 474

Reclamation of scrap, Blacksmiths' convention ..... 468

Reclamation of scrap, Storekeepers' convention ..... 293

Reclamation work, Costs needed in..... 166‡

Records of defects in equipment..... 1‡

Refrigerating system, Automatic, National Refrigerator Car Co..... 662\*

Refrigeration of freight in transit, by M. E. Pennington ..... 585\*

Refrigerator, Heater and Ventilator Car Co., Moore type car..... 208\*

Reliance Electric & Engineering Co., Heavy duty motors for direct current..... 1437\*

Re-organization, Constructive methods in... 167‡

Repair facilities and costs, Locomotive... 273‡

Repair facilities, The expense of poor... 166‡

Repairs and billing, Foreign car, by E. S. Way ..... 185\*

Repairs, Classification of locomotive, General Foremen's convention ..... 532

Repairs, Shopping passenger cars for classified, Painters' convention ..... 519

Repairs to freight equipment, Systematic, by F. G. Lister ..... 248

Replacers, Car, Reading Specialties Co..... 1469\*

Report of the chief inspector of locomotive boilers ..... 41\*

Report of I. C. C. division of safety..... 83

Reserve gear, Power, L. & N..... 602\*

Reservoir support, Union Pacific..... 628\*

Resistance, Interesting facts concerning grade, and car friction, by Hugh G. Bou-tell ..... 345

Retrenchment as affecting equipment..... 1248‡

Reverse gear, Brown power..... 1441\*

Reverse gear, Snyder..... 1440\*

Richmond, Fredericksburg & Potomac, Heavy Pacific type locomotive ..... 4\*

Riegel, S. S., Locomotive superheater performance ..... 339\*

Rink, G. W., Four-wheel trucks for passenger cars, discussion at A. S. M. E..... 28

Risque, John P., A simple grease cup plug... 414\*

Rivet cutter for freight car repairs, by H. M. Brown ..... 419\*

1438\*

Rivet forge, Mahr..... 657\*

Rivet steel, The effect of sulphur in..... 603\*

Riveter, Boyer pedestal, Chicago Pneumatic Tool Co..... 45\*

Riveter, Large pneumatic, Hanna..... 157\*

Riveter, Pneumatic door ring, Vulcan Engineering Sales Co..... 265\*

Riveter, Pneumatic punch and, Vulcan Engineering Sales Co..... 656\*

Riveting machine, Pneumatic, by E. A. Murray ..... 482\*

Robinson Connector Co., Train line connector ..... 44\*

Rogers, Robert W., Quick adjustment planer clamps ..... 208\*

Rock-hy & Co., E. J., Boring bar for cylinder and valve chamber bushings..... 297

Ross, J. E., Terminal cleaning of passenger cars (competition) ..... 421

Roundhouse foreman, The importance of the, by G. C. Christy..... 166‡

Roundhouse, Lost motion in the..... 251

Roundhouse wheel, Spokes in the (Engine terminal competition article)..... 573

Rules, Discussion of interchange, Car Inspectors' convention ..... 147\*

Rules for the safe handling of paints and oils, by J. W. Gibbons..... 111‡

Runs, Increasing length of locomotive..... 1376\*

Rules, Loading, M. C. B. convention..... 442†

Rules, The M. C. B. book of, by M. Glenn, Sr. .... 1296\*

Rules of interchange, Revision of M. C. B. Rules, Passenger car, Discussion at Car Inspectors' convention ..... 578

Rules, Suggestions regarding M. C. B..... 1279‡

Rules, Uniform interpretation of interchange Rules, The use of the M. C. B. loading... 1395‡

Ryan, Thomas F., Getting results in an engine-house (competition) ..... 424

Ryder, G. E., Discussion of superheater performance ..... 341

Rverson, Joseph T. & Son, Pneumatic spring banding press..... 104\*

S

Saddle bolts, Old man for drilling, by H. C. Spicer ..... 318\*

Safety appliances, M. C. B. convention... 1375

Safety Car Heating & Lighting Co., Belt tension device ..... 1436\*

Safety hangers, Brake beam..... 1279‡

Safety tread, with diamond grooving, Mason ..... 1269\*

Safety valve, Ashton ..... 1437

Safety valve, Crosby ..... 1442\*

Safety valve test gage, Bracket for, by C. S. Taylor ..... 39\*

Safety valves, by M. J. Cairns..... 631\*

Sagstetter, W. H., Better locomotive boiler inspection ..... 93\*

Sanitation of railway cars, The, by Thomas R. Crowder ..... 241

Sanitation, Passenger car cleaning and, by E. P. Marsh, Car Inspectors' convention... 579

Sauvage, Edouard, Express locomotives in France ..... 231\*

Saw, Metal (see Machine Tools).

Saw, Portable cut-off, by E. W. Hartough... 636\*

Saw teeth, The Simonds inserted..... 1470\*

Scaffold for boiler work, Portable, Elgin, Joliet & Eastern ..... 249\*

Scaffold for car repair tracks, Portable, by E. W. Hartough ..... 237\*

Scaling, Mixture for preventing, of stationary boilers ..... 651†

Scarritt-Comstock Furniture Corp., Simplex coach seat ..... 538\*

Schaefer Equipment Co., Trussed brake lever Schane, C. W., Electrode holder for electric welding and cutting..... 659\*

Schane, C. W., Waste storage can..... 259\*

Schaphorst, W. F., Chart for determining the expansion of metals..... 504\*

Schenck, Paul A., Handling a big engine terminal ..... 251

Schroeder Headlight Co., Incandescent electric headlight ..... 101\*

Schultz, F. C., Handling and repairing freight cars, Car Inspectors' convention... 642

Schultz, F. W., Operating a large engine terminal ..... 205

Schultz, F. W., Piston valve packing..... 39

Scott, J. R., President's address at T. E. A. convention ..... 561

Scrap and scrap classification, Storekeepers' convention ..... 291

Scrap, human or material, which is most worth while? by Harvey De Witt Wolcomb 169\*

Scrap, Pneumatic hammer for reclaiming, Tool Foremen's convention..... 476\*

Scrap, Reclamation of, Blacksmiths' convention ..... 468

Scrap reclamation, Chesapeake & Ohio..... 149\*

Scrap reclamation, Storekeepers' convention 293

Screw threads, Standardization of, M. M. convention ..... 1456\*

Scully-Jones & Co., Chuck for driving taps. 208\*

Seat, Double reclining, Heywood Bros. & Wakefield ..... 1268\*

Seat, Simplex coach, Scarritt-Comstock.... 538\*

Sellman, F. E., Detentions from a new angle Service, Cost versus..... 58‡

Shafting, Supporting, in concrete buildings, by C. C. Leech..... 40\*

Shear and bender, Combination pneumatic, by J. H. Clancy..... 596\*

Sheathing, Leakage of horizontal, by A. E. Hefelfinger ..... 276\*‡

Sheathing on box cars, Horizontal ..... 111‡

Sheathing, Shrinkage of box car..... 408

Sheehan, J. J., Cost of small shop tools, M. M. convention..... 1528\*

Shinaver, A. C., How to keep car inspectors Shocks, The cause of, in long freight trains 21

Shoes and wedges, Fitting up, by W. E. Warner, General Foremen's convention... 531\*

Shop efficiency, Essentials of, by G. W. Armstrong ..... 201\*

Shop grounds, Value of attractive..... 61‡

Shop improvement committee ..... 165‡

Shop Kinks

Air hoist, Chesapeake & Ohio..... 480\*

Air pump packing rings, Finishing, by F. R. Stewart ..... 461\*

Arch bars, Hand mirror for inspecting the inner side of..... 452\*

Babbitting crossheads, C. & O..... 462\*

Bracket for safety valve test gage, A. C. L. .... 39\*

Brake beam straightening press, N. Y. C., West..... 195\*

Brake levers, Manufacturing standard, C. & O..... 425\*

Broaching tool for reclaiming car brasses ..... 452\*

Carboy holder, C. & N. W..... 321\*

Carpet stretcher, by C. C. Leech..... 348\*

Chuck for the manufacture of fue cutter blades, C. & O..... 88\*

Coach window raiser, by C. C. Leech. 358\*

Cut-off saw, Portable, M. K. & T..... 636\*

Cylinder head grinder, by J. Lee..... 595\*

Device for holding journal box bolts, Tool Foremen's convention..... 474\*

Dies for reclaiming car axles, Blacksmiths' convention ..... 468\*

Drift for truing up supply valve stem guides, by F. W. Bentley, Jr..... 652\*

Drill jig for brake staffs, Tool Foremen's convention ..... 475\*

Page numbers under 1,000 refer to *Railway Mechanical Engineer*; those over 1,000 refer to the *Daily Railway Age Gazette*. \*Illustrated article; ‡editorial; †short non-illustrated article or note; ‡communication.

Shop Kinks—(Continued)

Driving box brasses, Fitting..... 360  
 Driving boxes, Reclaiming, A. C. L. 206\*  
 Dry pipes, Grinding, by V. T. Kropidowski 87\*  
 Eccentric keyway cutter, C. & O. 596\*  
 Electrode holder for electric welding and cutting, by C. W. Schane..... 659\*  
 Finishing car journal brasses, G. N. 31\*  
 Flue cutter blades, Chuck for the manufacture of, by E. A. Murray..... 88\*  
 Furnace, Lead pot, for heat treatment of steel..... 473\*  
 Gage cock stems, Box tool for refinishing ends of, Tool Foremen's convention..... 477\*  
 Gage for checking the location of wheels on the axle, P. & R. 514\*  
 Gage for steel wheels, Hocking Valley..... 648\*  
 Gage glass cutter, Chesapeake & Ohio..... 660\*  
 Gages for sorting old bolts and nuts, Can. Pac. 34\*  
 Grinders for superheater header and units, Tool Foremen's convention..... 476\*  
 Grinding dry pipe joints, C. & O. 425\*  
 Grinding rod packing cone rings, C. of Ga. 310\*  
 Holder-on for pneumatic tools, Tool Foremen's convention..... 474\*  
 Holder-on for riveting the boiler barrel to the wrapper sheet, Elgin, Joliet & Eastern..... 249\*  
 Holder-on for riveting tube sheets to the crown and side sheets, Elgin, Joliet & Eastern..... 250\*  
 Holding distributing valves in making repairs, by E. H. Wolf..... 142\*  
 Hose cart, Boilerwasher's, C. & O. 260\*  
 Hose stripping machine, A. C. L. 259\*  
 Injector steam pipe roller and expander, Big Four..... 525\*  
 Jack for removing expanded tires in the roundhouse, Tool Foremen's convention..... 477\*  
 Jack support for straightening steel car sills, Tool Foremen's convention..... 474\*  
 Jacking stall for steel car repairs, Santa Fe..... 535\*  
 Jacking stall for steel car repairs, Santa Fe..... 535\*  
 Jig for drilling holes in firebox wrapper sheets, Elgin, Joliet & Eastern..... 249\*  
 Jig for tube cutters, Texas & New Orleans..... 321\*  
 Lathe tools, tipped with high speed steel, Santa Fe..... 200\*  
 Locomotive repair indicator, St. Louis & San Francisco..... 99\*  
 Main reservoirs, Removing air pockets from, C. & E. I. 372\*  
 Milling cutters with inserted piece, Tool Foremen's convention..... 478\*  
 Molding gaskets for feed valves, C. & O. 320\*  
 Old man drilling post..... 589\*  
 Old man for drilling saddle bolts, by H. C. Spicer..... 318\*  
 Pipe bending machine, C. & O. 321\*  
 Piston rings, Vise chuck for filing, by R. J. Hickman..... 146\*  
 Planer clamps, Quick adjustment, by Robert W. Rogers..... 44\*  
 Plunger for holding bar stock..... 589\*  
 Pneumatic clamping and holding-on devices, C. R. R. of N. J. 655\*  
 Pneumatic hammer for reclaiming scrap, Tool Foremen's convention..... 476\*  
 Pneumatic hammers, Lubricating tank for, Tool Foremen's convention..... 477\*  
 Pneumatic spring shear and bender..... 596\*  
 Power operation of ratchet jacks, N. Y. C. 91\*  
 Pump for testing boilers, C. & E. I. 147\*  
 Quenching tanks for heat treatment of steel, water and oil..... 473\*  
 Rack for storing smoke box front ends, B. R. & P. 651\*  
 Radial drill chuck for locomotive cylinders, by R. J. Hickman..... 35\*  
 Rail saw, A reclaimed, Can. Pac. 359\*  
 Rivet cutter for freight car repairs, C. & O. 419\*  
 Riveting machine, Pneumatic, Chesapeake & Ohio..... 656\*  
 Scaffold for boiler work, Portable, Elgin, Joliet & Eastern..... 249\*  
 Scaffold for car repair tracks, Portable, M., K. & T. 237\*  
 Special truck for movement of material in standard boxes, Can. Pac. 33\*  
 Steam gage testing stand, A. C. L. 310\*  
 Steel, Welding high speed, to soft steel shanks, by H. W. Harris..... 87\*  
 Straightening press for steel car members, C. & E. I. 526\*  
 Taper attachment for turret lathes..... 141\*  
 Testing pneumatic tools, P. & R. 413\*  
 Tire heater, Double ring, A. C. L. 310\*  
 Tire heater, Portable, C. & O. 258\*  
 Tool for boring car wheels, Tool Foremen's convention..... 475\*  
 Tool holder, Special, for broken drills, A. C. L. 44\*  
 Triple valve pistons, Straightening, by J. A. Jesson..... 43\*  
 Truck for carrying couplers..... 452\*  
 Turning car journals, C. & N. W. 128\*  
 Vacuum cleaner, Can. Nor. 27\*

Shop Kinks—(Continued)

Valve chamber boring cutters, Tool Foremen's convention..... 478\*  
 Valve, Piston, packing rings, by John C. Murdock..... 88\*  
 Vaporizer, Portable kerosene, A. C. L. 43\*  
 Supporting shafting in concrete buildings, by C. C. Leech..... 40\*  
 Waste storage can..... 259\*  
 Welding high speed steel to soft steel shanks, by H. W. Harris..... 87\*  
 Shop management, A weak spot in..... 551§  
 Shop output, Increasing, by H. D. Wolcomb..... 589\*  
 Shop practice, Forge, by V. T. Kropidowski..... 253\*  
 Shop ratios, Comparative locomotive, by Henry Gardner..... 38\*  
 Shops, Standard methods for railway..... 493§  
 Side sheets, The mud-ring and the cracking of, Boiler Makers' convention..... 317\*  
 Simonds Mfg. Co., Inserted tooth metal-cutting saw..... 1470\*  
 Slack and draft gear maintenance..... 57§  
 Slack action in long passenger trains, Air Brake convention..... 299\*  
 Slack adjuster, Automatic, for freight cars, Gould Coupler Co. 1263\*  
 Slattery, J. T., President's Address, Air Brake convention..... 299\*  
 Smith, E. W., Efficient enginehouse organization..... 143\*  
 Smith, J. D., Testing pneumatic tools..... 413\*  
 Smith, Joseph, Care of boiler tubes..... 321\*  
 Smith, Joseph, Notes on the button-head radial stay..... 96\*  
 Smith, Leroy, Old man drilling post..... 589\*  
 Smoke and electrification in Chicago..... 11\*  
 Smoke elimination, T. E. A. convention..... 564\*  
 Smoke formation, The principles of..... 72\*  
 Smoke investigations in Chicago, Electrification and..... 3§  
 Smoke jack for passenger cars, Can. Nor. 308\*  
 Smoke lifter for locomotives, O. & C. Co. 1442\*  
 Smoke Prevention Association (see Meetings).....  
 Smoke prevention, Fuel economy and, M. M. convention..... 1475\*  
 Soap, The use of, in cleaning passenger cars for varnishing, Painters' convention..... 524\*  
 Souders, J. A., How to develop the car inspector (competition)..... 306\*  
 Southern Locomotive Valve Gear Co., Brown power reverse gear..... 1441\*  
 Southern Pacific, Apprentices on..... 97\*  
 Southern Pacific, Method of weighing counterbalances..... 530\*  
 Southern Ry., Dynamometer Car..... 62\*  
 Southwark Foundry & Machine Co., Punch press for making washers..... 601\*  
 Southwark Foundry & Machine Co., Universal tube welder..... 665\*  
 Spark arresters, Inspection of locomotive, and ash pans..... 659\*  
 Specifications and tests of materials, M. C. B. convention..... 1411\*  
 Specifications and tests of materials, M. M. convention..... 1514\*  
 Specifications, The purchase of paint on..... 494§  
 Specifications, The purchase of paint on railroad, Painters' convention..... 520\*  
 Specifications, Use of M. C. B. and M. M. Association..... 1396§  
 Speed indicators on locomotives..... 495§  
 Speller, F. N., Prevention of corrosion in pipe..... 227\*  
 Spicer, H. C., Double ring tire heater..... 310\*  
 Spicer, H. C., Old man for drilling saddle bolts..... 318\*  
 Spidy, E. T., Efficient reclamation of bolts and nuts..... 33\*  
 Spidy, E. T., A reclaimed rail saw..... 359\*  
 Spontaneous combustion of coal, The prevention of, by J. F. Springer..... 179\*  
 Spring bending press, Pneumatic, Joseph T. Ryerson & Son..... 104\*  
 Spring making and repairing, Blacksmiths' convention..... 466\*  
 Spring plank for car trucks, Sullivan..... 513\*  
 Spring shear and bender, Combination pneumatic, by J. H. Clancy..... 596\*  
 Springer, J. F., The prevention of spontaneous combustion of coal..... 179\*  
 Springer, J. F., Spontaneous combustion of coal..... 124\*  
 Standard Alloys Co., Uranium in high speed steel..... 540\*  
 Standard Cax Truck Co., Lateral motion journal box..... 1268\*  
 Standard Union Co., Locking pipe union..... 103\*  
 Standards and recommended practice, M. C. B. report on..... 1286\*  
 Standards and recommended practice, Revision of M. M. convention..... 1454\*  
 Standpipe and throttle arrangement, Baldwin Locomotive Works..... 429\*  
 Staybolt ends, Cutting off, with oxy-acetylene Boiler Makers' convention..... 315\*  
 Staybolt machines, Dethreading attachment for the Lassiter, S. L. Gary..... 481\*  
 Steam gage testing stand, by H. E. Opfinger..... 310\*  
 Steam pipes for reciprocating engines, Size of..... 568†  
 Steaming with smaller sizes of coal, More rapid..... 414†  
 Steel, Alloy, in locomotive design, by L. R. Pomeroy, M. M. convention..... 1499\*

Steel, Carbon and high-speed, Blacksmiths' convention..... 466\*  
 Steel, Conservation of high speed..... 111\*  
 Steel, Corrosion and boiler..... 494†  
 Steel, The effect of sulphur in rivet, by J. S. Unger..... 657\*  
 Steel for gears..... 318†  
 Steel, Heat treatment of, by George Hut-ton (competition)..... 418\*  
 Steel, Heat treatment of, Tool Foremen's convention..... 470\*  
 Steel, High speed, tipped lathe tools, by E. J. McKernan..... 200\*  
 Steel, Uranium in High Speed, Standard Alloys Co. 540\*  
 Steel? What is heat-treated..... 111†  
 Steel? What is heat-treated (competition announcement)..... 165†  
 Steel? What is heat-treated..... 273†  
 Steel? What is heat-treated, by Lawford H. Fry..... 335\*  
 Stephenson, W. C., Special tool holder for broken drills..... 44\*  
 Stewart, F. R., Finishing air pump packing rings..... 461\*  
 St. Louis & San Francisco, Locomotive repair indicator..... 98\*  
 St. Louis & San Francisco, Making bottom brake rods without welds..... 37\*  
 St. Louis & San Francisco, Oil cans of rational design..... 91\*  
 St. Louis & San Francisco, A record cylinder weld..... 199\*  
 Stocker, C. E., Ratchet grease cup..... 426\*  
 Stoker, Ko-Shovel mechanical, Goetz Co. 264\*  
 Stoker, The mechanical, Goetz Co. 1445†  
 Stokers and fuel economy, Mechanical..... 332†  
 Stokers, Mechanical, M. M. convention..... 1451\*  
 Stoking, Advantages of mechanical, T. E. A. convention..... 561\*  
 Storekeepers' Association convention..... 274†  
 Storekeepers' Association convention report Strain, C. E., Gage for steel wheels..... 648\*  
 Strike hastens publication..... 439†  
 Strike vote, Train employees to take..... 1424†  
 Stull, Howard W., Gage for checking the location of wheels on the axle..... 514\*  
 Stull, Howard W., Repairing angle cocks..... 309\*  
 Styers, Harold, Getting results in apprentice schools..... 99\*  
 Suggestions, Encourage, from the men, by John V. Le Compte..... 95\*  
 Sullivan spring plank for car trucks..... 513\*  
 Sulphur, The effect of, in rivet steel, by J. S. Unger..... 657\*  
 Summers Steel Car Co., Rolled steel truck side frame..... 1261\*  
 Superheat, Increases in degree of..... 1423†  
 Superheat in switching locomotives..... 332†  
 Superheater flues, Cleaning and maintaining, Boiler Makers' convention..... 314\*  
 Superheater, Grinder for header and units, Tool Foremen's convention..... 476\*  
 Superheater locomotives, M. M. convention 1483\*  
 Superheater locomotives, T. E. A. convention..... 615\*  
 Superheater performance, by S. S. Riegel..... 339\*  
 Superheating slide valve locomotives..... 1472†  
 Supply manufacturer, The mechanical department..... 386†

Supply Trade Notes

Acme Ball Bearing Co..... 330\*  
 Acme Supply Co..... 271, 329, 489\*  
 Adams, J. L..... 329\*  
 A. G. A. Railway Light & Signal Co. 381\*  
 Ahrens, C. R..... 608\*  
 Allen, S. G..... 163\*  
 Alter, F..... 161\*  
 American Arch Co..... 436\*  
 American Brake Shoe & Foundry Co. 270, 382, 544\*  
 American Car & Foundry Co., 108, 161\* 163\*  
 American Car & Ship Hardware Co. 162\*  
 American Flexible Bolt Co..... 383\*  
 American International Corp..... 271, 608\*  
 American Locomotive Co..... 329, 547\*  
 American Railway Supply Co..... 608, 672\*  
 American Steel Foundries..... 54, 674\*  
 American Steel & Wire Co..... 491\*  
 American Tool Works Co..... 272\*  
 Anchor Packing Co..... 609\*  
 Anthony, J. T..... 436\*  
 Armour & Co..... 674\*  
 Armstrong Bros. Tool Co..... 544\*  
 Ashton Valve Co..... 491\*  
 Austin Engineering Associates..... 609\*  
 Austin, William A..... 609\*  
 Averill, E. A..... 162\*  
 Bailie, Frank Howard..... 54\*  
 Baker, E. H..... 216\*  
 Barba, W. P..... 610\*  
 Barney & Smith Car Co..... 382\*  
 Barrett Co..... 545\*  
 Barron, C. M..... 490\*  
 Basford, G. M..... 162\*  
 Basford Co., G. M..... 162\*  
 Bentley, W. H..... 217\*  
 Bethlehem Steel Co..... 329, 608\*  
 Binkey, L. G..... 545\*  
 Bird & Co., J. A. & W..... 673\*  
 Bonnot Co..... 381\*  
 Boss Nut Co..... 216\*  
 Breckenridge, H. L..... 329\*  
 Bright, Frederick W..... 674\*  
 Brower, R. M..... 271\*  
 Brown, A. C..... 271\*

Page numbers under 1,000 refer to *Railway Mechanical Engineer*; those over 1,000 refer to the *Daily Railway Age Gazette*. \*Illustrated article; †editorial; ‡short non-illustrated article or note; †communication.



Supply Trade Notes—(Continued)

Brown Hoisting Machinery Co.	271
Buick Automobile Co.	436
Buick, J. M.	108
Bunnell, F. O.	161
Bulker, J. E.	610
Burdett Oxygen Co.	54, 672
Burnside Steel Co.	608
Cain, D. E.	547
Cambria Steel Co.	270, 329, 330
Camel Co.	161, 673
Cameron & Co., R. W.	546
Canadian Locomotive Co., Ltd.	161*, 216
Carnegie Steel Co.	672
Carrall, P. J.	163
Carry, E. F.	56*
Casey, William	216
Caspers, W. F.	672
Caughey, Edward G.	381
Central Foundry Co.	382
Chicago Car Heating Co.	672
Chur, Walter	491
Clements, B. A.	272*
Cloos, W. D.	546
Coburn, R. G.	216
Commercial Acetylene Railway Light & Signal Co.	381, 383
Connecticut Electric Steel Co., Inc.	491*
Conwell, W. L.	56*
Cook, George T.	383*
Cook, W. G.	436
Corrugated Bar Co.	489
Crawford, D. A.	108*
Creer, H. E.	217, 673
Cross, C. W.	54
Cullen, E. S.	270
Curtz, William Cooper	672*
Curtain Supply Co.	216
Damascus Brake Beam Co.	548*
Daniels, H. E.	544*
Dauch, J. J.	490*
Dayton Manufacturing Co.	271
Delamater, G. R.	382
Denker, Henry B.	545
Derickson, Thomas M.	381*
Dick Company, Inc., R. & J.	608
Dickson, W. B.	381
Dillon, Sydney	672
Dimmick, James C.	329, 382*
Dixon, J. E.	108*
Dodge, James Mapes	54
Dow, Herbert W.	672
Dressel Railway Lamp Work	330
Dunbar, Thomas	270
Duntley Co.	546
Eastman, Wm. E.	329
Eaton, F. H.	108, 163*
Economy Devices Corp.	109*
Edgewater Steel Co.	608
Edison Storage Battery Co.	108, 161*, 330, 381
Edison Storage Battery Supply Co.	547
Electric Storage Battery Co.	217
The Elcon Co.	489
Elliott, P. M.	161
Ellis, Clifford J.	270, 330*
Ellyson, H. K.	545
Engel & Havenor	489
Equipment Improvement Co.	54
Ettinger, Charles D.	546*
Evans, G. I.	270
Evans, Harry M.	489
Evans, Mitchel A.	217
Fairbanks, Morse & Co.	163
Farley, A. J.	54
Fay, Frank L.	329, 382*
Fearon, Daniels & Co.	382*
Finnell, H. W.	608*
Fisher, Edward Cumberland	547*
Flanagan, Harry	608
Flanagan, T. F.	490*
Flint & Chester, Inc.	54, 108
Ford, P. J.	383
Ford Co., P. J.	544
Forsyth, B. H.	54, 217, 216
Fox, G. F.	270
Francy, M. D.	547
Franklin Mfg. Co.	547
Franklin Railway Supply Co.	54, 55, 163*, 216, 490, 490*
Frohman, S.	216
Galena Signal Oil Co.	436
Garlock Packing Co.	608
Gaston, Williams & Wigmore, Inc.	110*
Gayley, O. C.	382*
Gilman, Joseph Thayer	672*
Goddard, J. Sterling	436
Gold Car Heating & Lighting Co.	672*
Goldschmidt Thermit Co.	329, 270
Goodrich Co., B. F.	436
Goodyear Tire & Rubber Co.	271*
Grant, F. W.	216
Gray, H. A.	608
Greenfield Tap & Die Corp.	329, 382
Greenville Steel Car Co.	381, 546*
Greenwood, W. E.	381, 545
Grip Nut Co.	329, 544, 545
Groce, G. H.	217
Guess, J. H.	109*
Hale & Kilburn Co.	217
Hallett, Reuben C.	544
Hammack, Henry C.	329
Harlan & Hollingsworth Corp.	54
Harper, William P.	381
Harrison Railway Specialties Co.	490*, 608*
Harrison Safety Boiler Wks.	108
Haskell & Barker Car Co.	56*, 108*, 163

Supply Trade Notes—(Continued)

Hayes, W. L.	491
Hendce, Edward Thomas	674*
Henderson, George R.	54
Herrington, C. F.	381
Hess-Bright Mfg. Co.	673
Hewitt, C. M.	216
Hewitt Co.	489
Hibbard, Howard H.	545*
Hill, J. A.	109*
Hill, R. W.	271
Himmelright, R. J.	436*
Hoffstot, H. P.	56*
Holden & White	216
Hopkins, Thornton	489
Hulst, John	608
Humes, W. Sharon	489
Ilyatt Roller Bearing Co.	489
Ilydraulic Press Mfg. Co.	270, 673
Imydan, F. T.	548*
Imperial Iron & Steel Works	270
Inter-Continental Machinery Corp.	610
International Oxygen Co.	436
International Pulverized Fuel Corp.	382
Ivers, W. H.	436
Johns-Manville Co., H. W.	382, 608
Johnson Bronze Co.	162
Johnstone, Homer C.	608
Jones, B. B.	163
Jones & Laughlin Steel Co.	608
Jordan, L. E.	216
Jordan, L. F.	381*
Judd, George M.	544
Kansas City Bolt & Nut Co.	163
Kay & Ess Co.	108
Kilby Car & Foundry Co.	108
Kilpatrick, John B.	330
Kincaid Foundry & Machine Co.	545
Kincaid, R. N.	436
Kirschke, M. T.	436
Kloss, H. C.	55
Lagonda Mfg. Co.	672
Lameroux, D. P.	608, 609*
Landreth, J. P.	609*
Lee, Henry	163
Liddle, C. A.	108*, 163
Lima Locomotive Corp.	610
Linburg, W. H.	108*, 109*, 162, 329, 546, 162
Lincoln, P. M.	56*
Lockwood, C. N.	216
Locomotive Feed Water Heater Co.	162
Lonsbury, Charles	608, 672
McCallister, M. M.	383
McCord & Co.	217
McDonald, J. H.	329
McDonough, W. H.	271*
McEnulty, J. F.	55
McGinness, F. V.	161*
McKinney, Robert Cochran	609*
McVay, D. R.	545
Maitland, A. S.	381
Magor Car Corp.	544
Mason, R. L.	108
Metals Production Equipment Co.	216
Midvale Steel Co.	270, 329, 330
Midvale Steel & Ordnance Co.	381
M'Lain, J. E.	270
Modern Tool Co., The	329, 672
Monarch Steel Castings Co.	672
Morris, L. B.	272
Motley & Co., Inc., Thornton N.	608
Mudge & Co.	217*, 673*
Mudge, Burton W.	547*
National Graphite Lubricator Co.	54
National Tube Co.	544
Neale, J. C.	270
Neeland, Marvin A.	608
Nicholl, F. M.	271
Niles-Bement Pond Co.	270
Nordberg Mfg. Co.	672
Northwest Steel Company	672
O'Brian, T. P.	210
O'Malley-Bears Valve Co.	163
Osthy, Oscar F.	436*
Ott, Albert J.	329
Peabody, G. H.	545*
Pennsylvania Tank Car Co.	381
Pennsylvania Tank Line	381
Pennsylvania Steel Co.	382
Peters, Frank R.	54
Pfager, C. W.	270
Pollak Steel Co.	548
Porter, H. K.	162
Porter Co., H. K.	54
Postlethwaite, C. E.	55*
Possom, Fay E.	672*
Pratt & Letchworth Co., Ltd.	608, 673*
Pressed Steel Car Co.	55*, 56*, 110*, 270
Pullman Co.	270
Pyre-National Co.	383
Pyrene Manufacturing Co.	490*
Q. & C. Co.	490
Quigley Furnace & Foundry Co.	216
Railway Appliances Co.	217
Railway & Mine Supply Co.	545
Railway Motor Car Co. of America	547
Ralston Steel Car Co.	544
Ramsey, George T.	381
Rayburn, E. R.	547
Reeder, N. S.	55*
Refrigerator, Heater & Ventilator Car Co.	436*
Richey, E. W.	489
Rider, J. B.	55*
Robinson Connector Co.	270
Robinson, Dwight E.	608

Supply Trade Notes—(Continued)

Ross, William Barlow	673*
Roy, F. V.	163
Ryerson & Son, Jos. T.	216, 674*
Safety Car Heating & Lighting Co.	673
Safety First Mfg. Co.	547, 672
Sawyer, E. T.	330
Schafer, A. E.	108
Sears, Louis	546
Selby Safety Flag Co.	491
Sharp, W. E.	545*
Shaw, Henry M.	381
Sherritt & Stoer Co., The	216
Sherwin, Henry Alden	381, 436
Schoenheiter, H. K.	271
Schroeder, C. F.	329
Sheridan, R. B.	271
Sherritt & Stoer Co., The	329
Signal Accessories Co.	608
Sinclair, Robert D.	672*
Sinkler, Joseph	109*
S. K. F. Ball Bearing Co.	54, 270
Smith, E. B.	271*
Smith, Stanley H.	608
Smith, S. K.	54
Smith, Oliver J.	610
Smyth, W. D.	270
Snyder, Frank	162
Southern Locomotive Valve Gear Co.	329
Southern Wheel Co.	161
Sperry, C. D.	270
Standard Forgings Co.	489
Standard Heat & Ventilation Co.	329
Steinle, Leo C.	672
Stocks, W. H.	489
Stoddard, Solomon	383*
Sutcliffe, P.	108
Templeton, Kenly & Co., Ltd.	608*
Terry, Charles M., Inc.	490
Terry, J. L.	490
Terry Steam Turbine Co.	329
Tesseyman, J. E.	109*
Texas Co.	546
Thomas, Walter D.	489
Thornburgh, W. N.	490*
Titanium Alloy Mfg. Co.	608
Transportation Utilities Co.	56*
Trube, G. A.	489
Turner, H. N.	108
Union Metal Products Co.	545
Union Railway Equipment Co.	217
United States Light & Heat Corp.	491, 608
United States Steel Corp.	608
Universal Arch Co.	272, 330
Van Dorn Electric Tool Co.	544
Voelker, Herman	544
Vulcan Brake Shoe & Equipment Co.	271
Vulcan Fuel Co.	608
Vulcan Process Co., Inc.	216
Walker, H. E.	54
Wall, G. L.	162
Wallace, F. G.	216
Wampler, Wm.	489
Waynesboro Foundry & Machine Co.	491
Wegener, A. B.	161
Wenz, George W.	381
Western Electric Co., Inc.	381
Western Steel Car & Foundry Co.	55*, 270
West Disinfecting Co.	544, 545
Westinghouse Air Brake Co.	489
Westinghouse Electric & Mfg. Co.	56*
Westinghouse Traction Brake Co.	489
Wheatley, A. W.	161*
White, G. A.	608
White, W. McK.	216
Whiting, A. T.	54
Willard Storage Battery Co.	546, 609
Willcoxson, W. G.	216
Willson, Edwin L.	491*
Wilson, J. W.	108
Wilson, Willard	436*
Wolff, H. W.	108, 161*
Wood, R. H.	672
Woodard, W. E.	546*
Woodin, W. H.	161*
Worth Bros. Co.	270, 330
Wymer, C. J.	329
Yctman, William H.	381*
Youngstown Steel Car Co.	54, 109*
Swanson, C. N., Car department apprentices, second prize, Car Inspectors' competition	639*
Sweeley, E. H., Graphite cylinder lubricator	104*

T

Tanks, water and oil quenching, for heat and treatment of steel, Tool Foremen's convention	473*
Tap, The "Gun," Greenfield Tap and Die Corp.	429*
Tap, The "Gun," A correction	483
Taper attachment for turret lathes, G. N.	141*
Tapping machine (see Machine Tools)	
Taylor, C. S., Bracket for safety valve test gage	39*
Temperature control system for passenger cars, Thermostatic, Gold	1265*
Tempering tools, Electric furnaces for, Illinois Central	423*
Tenders, Treatment of the interior and exterior of, Painters' convention	518
Terminal car cleaning yards, by R. N. Miller (competition)	357
Terminal competition, Passenger car	57*
Terminal competition, Passenger car	111*
Terminal inspection, Passenger, by R. S. Mounce	239*

Page numbers under 1,000 refer to *Railway Mechanical Engineer*; those over 1,000 refer to the *Daily Railway Age Gazette*. \*Illustrated article; †editorial; ‡short non-illustrated article or note; §communication.

Terminal yard, The passenger car, by W. W. Warner (competition).....	402	Tulien, T. S., The Santa Fe method (apprentice competition).....	198	Welded joints, Allowable strength of.....	456†	
Test Committee report, Painters' convention.....	515	Turner, Walter V., Empty and load brake equipment.....	355*	Welder, Universal tube, Southwark Foundry & Machine Co.....	665°	
Test of the Young valve and valve gear.....	229*	Turret toolpost for engine lathes.....	1439*	Welding, Autogenous, in boiler repairs.....	157†	
Tests, Keeping track of service, by E. S. Barnum.....	337*	Twist, George, Some notes on engine terminals.....	252	Welding castings.....	338†	
Tests, Locomotive impact, by C. B. Young.....	288*	<b>U</b>			Welding cast steel truck frames.....	1395‡
Tests, Water reading in locomotive, by Towson Price.....	126*	Uncoupling rigging, Passenger car, McConey & Torley Co.....	1266	Welding, Electric, in railroad shops, by Gordon Fox.....	591°	
Texas & New Orleans, Jig for tube cutters.....	321*	Underframes, The reinforcing of.....	111‡	Welding in Boiler repairs, Electric, Boiler Makers' convention.....	312	
Thermit welding (see Welding).		Underwood & Co., H. B., Machine for grinding reflex water glasses.....	207*	Welding in boiler repairs, Oxy-acetylene.....	649*	
Thomas, F. W., Apprenticeship on railroads, M. M. convention.....	1509	Unzer, J. S., The effect of sulphur in rivet steel.....	657*	Welding of cast-steel truck side frames and bolsters, M. C. B. report.....	1417	
Thomas, F. W., Training young men for promotion.....	597	Union Metal Products Co., National car door.....	537*	Welding, Oxy-acetylene and electric, Blacksmiths' convention.....	469	
Thompson, W. O., Address at Car Inspectors' convention.....	572	Union Pacific, Air reservoir support.....	628*	Welding pipes.....	427†	
Thomson, S. G., Four-wheel trucks for passenger cars, discussion at A. S. M. E.....	28	Union Pacific, Belt rail applied to all-steel automobile cars.....	513*	Welding safe ends, Electric.....	653*	
Threading machine (see Machine Tools).....		Union Pacific, Depressed aisle strips.....	402*	Welding, Progress in electric.....	204	
Throttle and standpipe arrangement, Baldwin Locomotive Works.....	429*	Union Pacific, Extension exhaust pipe seats.....	525*	Welding, Tube, Blacksmiths' convention.....	463	
Throttle, Woodard, American Locomotive Co.....	48*	Union Pacific, Facing driving box shoe and wedge faces.....	652*	Welding tubes in the back tube sheet.....	274‡	
Time, Procrastination, the thief of, by F. A. Whitaker.....	414	Union Railway Equipment Co., Refrigerator car brine tank valve.....	322*	Western Railway Club (See Meetings).....		
Tinware, Standardization of, Storekeepers' convention.....	293	United Railways of Havana, A simple grease cup plug.....	414*	Westinghouse Electric & Mfg. Co., Arc welded cutting tools.....	1469*	
Tire heater, Double ring, by I. C. Spicer.....	310*	Universal Car Seal & Appliance Co., Effective car door fasteners.....	103*	Westinghouse Electric & Mfg. Co., Induction motor for turntables and transfer tables.....	373*	
Tire heater, Portable, by E. A. Murray.....	258*	Universal Draft Gear Attachment Co., Friction tandem draft gear.....	1311*	Wheel clamp and jack block, Can. Nor.....	22*	
Tires, Jack for removing, in the roundhouse, Tool Foremen's convention.....	477*	Universal Grain Door Co., Grain door.....	155*	Wheel committee report, The.....	1356‡	
Tires, Turning of, M. M. convention.....	1495	Universal Valve Co., Non-packing valve.....	207*	Wheel slip in electric locomotives, Chattering, by G. M. Eaton.....	178*	
Tollerton, W. J., Address at Blacksmiths' convention.....	463	Uranium in high speed steel, Standard Alloys Co.....	540	Wheels, The cause of slid flat.....	247*	
Tonnage rating, Train resistance and, M. M. convention.....	1523*	U. S. Light & Heat Corp., Body hung generator.....	1468*	Wheels, Flat.....	60‡	
Toohy, T. E., Better locomotive boiler inspection.....	94*	<b>V</b>			Wheels, Gage for checking the location of, on the axle, by Howard W. Stull.....	514*
Tool foreman, The engine house and the.....	493‡	Vacuum cleaner, Can. Nor.....	27*	Wheels, Gage for steel, by C. E. Strain.....	648*	
Tool Foremen's Association convention.....	470*	Valve chamber boring cutters, Tool Foremen's convention.....	478*	Wheels, Holding down, while changing brasses, by W. E. Lemp.....	307*	
Tool holder, Special, for broken drills, by W. C. Stephenson.....	44*	Valve chamber, Piston, for slide valve cylinders, G. F. Cotter Supply Co.....	430*	Wheels, Inspecting cast iron under freight equipment, by J. P. Yaeger.....	30	
Tool room equipment and tools, Tool Foremen's convention.....	478*	Valve, Detroit ball, Detroit Valve Co.....	155*	Wheels, M. C. B. convention.....	1359*	
Tools and formers, Blacksmiths' convention.....	466*	Valve gear and valve, Test of the Young.....	229*	Wheels, Tool for boring car, Tool Foremen's convention.....	475*	
Tools, Caring for locomotive, by John F. Long.....	536*	Valve gear device, Kingan-Ripken.....	601	Wheels, Works of the Association of Mrs. of Chilled Car.....	570	
Tools, Cost of small shop, by J. J. Sheehan, Master Mechanics' convention.....	1528*	Valve, Intercepting for Mallet locomotives, Economy Devices Corp.....	263*	Wheeling & Lake Erie, Steel frame automobile cars.....	401*	
Tools for steel car repairs, Special Tool Foremen's convention.....	472*	Valve, Locomotive safety, Crosby.....	1442*	Wheeling & Lake Erie, 70-ton Gondola cars.....	406*	
Tools, Getting the most out of, by B. W. Benedict.....	35*	Valve, Multiplate, O'Malley-Beare Valve Co.....	153*	Whelan, M. C., Oxy-acetylene cylinder weld.....	388†	
Tools, Standard shop.....	386‡	Valve packing, Piston, by F. W. Schultz.....	39	Whitaker, F. A., The question of promotion.....	74	
Toolpost for engine lathes, Turret, Phoenix Manufacturing Co.....	1439*	Valve packing rings, Piston, by John V. LeCompte.....	254	Whitaker, F. A., Procrastination, the thief of time.....	414	
Track facilities for electric locomotives, Norfolk and Western.....	121*	Valve, Refrigerator car brine tank, Union Railway Equipment Co.....	322*	Whiting Foundry Equipment Co., Crane trolley.....	431*	
Train lighting and equipment, M. C. B. convention.....	1380*	Valve, Steam pressure regulating, Grenlaw Valve Co.....	207*	Whiting Foundry Equipment Co., Screw-jack hoist for handling Mallet locomotives.....	48*	
Train line connector, The Robinson.....	482*	Valves and valve bushings, Design and materials for, M. M. convention.....	1496*	Wiener Machine Co., Portable drilling and tapping machine.....	262*	
Train resistance and tonnage rating, M. M. convention.....	1523*	Valves, Ashton safety.....	1437	Window, Clear vision cab, by F. Hopper.....	603*	
Train resistance formulas, The Kiesel, by A. J. Wood.....	627	Valves, Safety, by M. J. Cairns.....	631*	Window raiser, Coach, by C. C. Leech.....	358*	
Trains, Handling freight, T. E. A. convention.....	615	Van Wormer, R. B., Operation of a general flue shop.....	653*	Windows, Passenger cars.....	440‡	
Trains, Proper braking of long passenger.....	495‡	Vaporizer, Portable kerosene, by H. E. Opfinger.....	43*	Wilcox, Lawrence, Car foreman's Responsibility for air brake conditions.....	134	
Transportation Utilities Co., Universal trap door.....	1262*	Varnish remover for removing paint, Painters' convention.....	523	Willis, A. N., Locomotive maintenance and fuel economy, Fuel convention.....	281	
Trap, A simple steam, Johns-Manville.....	1439*	Varnishing, The use of soap in cleaning passenger cars for, Painters' convention.....	524	Wisconsin Electric Co., Dumore portable grinder.....	604*	
Trap door, Universal, Transportation Utilities Co.....	1262*	Ventilator, Dining car blower, Mudge & Co.....	1265*	Wolcomb, Harvey De Witt, The danger of overdoing things.....	73	
Trap doors on observation cars.....	357	Ventilator, Santa Fe refrigerator car.....	136	Wolcomb, Harvey De Witt, Handling a big engine terminal (competition).....	417*	
Traveling engineer, How best to educate the, the road foreman and the fireman, M. M. convention.....	1494	Vision, Broaden your.....	614‡	Wolcomb, H. D., Increasing shop output.....	589	
Traveling Engineers' Association convention.....	561*	Vulcan Engineering Sales Co., Cold metal sawing machine.....	376*	Wolcomb, Harvey De Witt, Making efficient car inspectors.....	31	
The Traveling Engineers' Association (see Meetings).....	561*	Vulcan Engineering Sales Co., Pneumatic door ring riveter.....	157*	Wolcomb, Harvey De Witt, Scrap, human or material.....	169*	
Traveling Engineers' Association convention.....	561*	Vulcan Engineering Sales Co., Pneumatic punch and riveter.....	265*	Wolf, E. H., Holding distributing valves in making repairs.....	142*	
Tread, safety, with diamond grooving, Mason Triangle for use in tracing, by Hugh G. Boutell.....	568*	<b>W</b>			Wood, Arthur J. The Kiesel train resistance formulas.....	627
Triple valve pistons, Straightening, by J. A. Jesson.....	43*	Warner, W. E., Fitting up shoes and wedges, General Foremen's convention.....	531*	Wood, Professor A. J., Tests of passenger car radiators, M. M. convention.....	1459*	
Triplex Lock Co., Bnx car door lock.....	540*	Warner, W. E., Locomotive counterbalances, General Foremen's convention.....	528*	Wood, Chas. E., Suggestions for improvement in car design (competition).....	347	
Truck, Elevating platform, Elwell-Parker Electric Co.....	1391*	Warner, W. E., The passenger car terminal yard (competition).....	402	Wood, Dennistoun, Suggestions for improvement in car design (competition).....	347	
Truck frames, Welding cast steel.....	1395‡	Washers, Punch press for making, Southwark Fdry. & Mach. Co.....	601*	Woodward, W. E., Operation of radial coupled axles, discussion at A. S. M. E.....	18	
Truck pedestals, Reclaiming car.....	82*	Waste storage can, by C. W. Schane.....	259*	Woodbridge, H. C., Fuel economy.....	71	
Truck safety attachment, Wright Safety Air Brake Co.....	665*	Water consumption, Locomotive.....	69*	Wrench, The La Ruck pipe, Mechanical Specialty Co.....	431*	
Truck side frame, Rolled steel, Summers.....	1261*	Water coolers for passenger cars, Canadian Government Railways.....	460*	Wright, R. V., Address at Car Inspectors' convention.....	573	
Truck side frames and bolsters, Welding of cast-steel, M. C. B. convention.....	1417	Water glasses, Machine for grinding reflex, H. B. Underwood & Co.....	207*	Wright Safety Air Brake Co., Truck Safety attachment.....	665*	
Truck, Six-wheel, Woodward Iron Co.'s 100-ton car.....	635*	Water readings, Pneumatic device for taking in locomotive tests, by Towson Price.....	126*	Wymer, C. J., Freight car construction, maintenance and abuse.....	139	
Truck Special, for movement of material in standard boxes, Can. Pac.....	33*	Water softener with increased settling space, L. M. Booth Co.....	324*	<b>Y</b>		
Trucks, Four-wheel, for passenger cars.....	333‡	Water treatment on the Missouri Pacific.....	393*	Yaeger, J. P., Inspecting cast iron wheels under freight equipment.....	30	
Trucks, Master Car Builders' convention.....	1380	Waugh Draft Gear Co., High capacity friction draft gear.....	1269	Yards, Terminal car cleaning, by R. N. Miller (competition).....	357	
Trucks, Spring plank, Sullivan.....	513*	Waugh Draft Gear Co., Passenger car buffer.....	1313	Young, C. D., Four-wheel truck for passenger cars, discussion at A. S. M. E.....	27	
Tube cutters, Jig for, by Edgar Barnes.....	321*	Way, E. S., Foreign car repairs and billing.....	185*	Young, C. D., Heat treatment of carbon-steel locomotive axles: Water vs. oil quenching.....	398*	
Tube safe ends, Electric welding.....	653*	Weight of steel passenger cars, The.....	1356‡	Young, C. D., Locomotive impact tests.....	288*	
Tube safe ends, Electric welding.....	653*	Weld, A double thermit, by Robert W. Miller.....	257*	Young, C. D., Operation of radial coupled axles, discussion at A. S. M. E.....	19	
Tube sheets, The bulging of front, Boiler Makers' convention.....	313	Weld, A record cylinder.....	199*	<b>Z</b>		
Tube welder, Universal, Southwark Foundry & Machine Co.....	665*	Weld, Oxy-acetylene cylinder, by M. C. Whelan.....	388†	Zilen, Victor W., Design of passenger equipment.....	189*	
Tube welding, Blacksmiths' convention.....	463	Welds, Properties of autogenous.....	234†			
Tubes, Blowing out stationary boiler.....	157†	Welded cutting tools, Arc, Westinghouse.....	1469*			
Tubes, Do long, vibrate? Boiler Makers' convention.....	313					
Tubes, Welding, in the back tube sheet.....	274‡					

# Railway Mechanical Engineer

Volume 90

January, 1916

No. 1

## Our Change in Name

Attention was directed at length in last month's issue to our new name—*Railway Mechanical Engineer*. As a successor to the *American Engineer*, and the *Railway Age Gazette, Mechanical Edition*, we hope it will find a warm place in your hearts. The change in name does not mean that there will be any change in editorial policy; in fact, practically the same policies will be followed in the effort to develop an even bigger, better and stronger paper.

## Steel Freight Car Competition Award

The first prize of \$35 in the competition on "Lessons to be Learned From Experience with Steel Freight Cars" has been awarded to Millard F. Cox, assistant superintendent of machinery, Louisville & Nashville, Louisville, Ky. The article appears elsewhere in this issue, as does also an important study on the life of steel freight cars which was presented at the December meeting of the Railway Club of Pittsburgh, by Samuel Lynn, master car builder of the Pittsburgh & Lake Erie. One thing which is made clear in both of these articles is that the problem of repairing and maintaining steel freight cars has proved to be not nearly as serious as was at first anticipated. This was forecast several years ago by the *American Engineer*, and was later demonstrated by studies of steel freight car maintenance which were made on the Baltimore & Ohio (May, 1907, page 157), Pittsburgh & Lake Erie (January, 1908, page 1) and Pennsylvania Railroad (March, 1909, page 81). While special facilities have had to be provided, they have proved to be simple and comparatively inexpensive. Nor has it proved a difficult task to train the men for this special work.

## Records of Defects in Equipment

The practice of having reported to the mechanical department defects found in the construction and design of the rolling stock, no matter how small or seemingly insignificant, is important. Reports from the men in the field, such as inspectors and repairmen, as to the troubles they experience with the equipment under their care and, if possible, suggestions as to how these troubles may be overcome, should always be welcomed by the designers of equipment. It may be very small items, such as bolts or rivets that continually fail because they are not large enough, or it may be a more important matter of the frame construction—all should be considered and, being properly recorded, will be of material assistance to the designers when new equipment is to be built or general repairs are to be made. The recording of defects should not necessarily be restricted to the repairmen or the inspectors; the employees all over the line should be in a position materially to assist in this matter. Roads that have followed this practice consistently have been able to so improve their cars and locomotives as to greatly reduce failure, maintenance costs and loss and damage to freight.

## Conservation of High Speed Steel

With the increase in price of high speed steel, since the supply of tungsten has been cut off from Germany, it is apparent that anything that can be done to conserve this product will be very much worth while. If the war continues much longer it will not be so much a question of price, but rather whether high speed steel can be obtained or not. Some roads have already made a careful study of the situation and find that by welding on high speed steel tips to lathe tools a considerable saving can be made. In one instance the ends of drills have been slotted out and a piece of high speed steel welded in by the electric welding process. It is of the utmost importance that serious consideration be given the use and disposal of this grade of steel. Should the supply become exhausted it is evident that where it was generally used the speed of the machines will have to be materially reduced, and in this way greatly affect the operation and output of the shop. Those of our readers who have devised special methods for using or of getting more service out of their high speed steel could perform no greater service to their fellow railway men than by publishing the methods they follow. To this end we would be very glad to receive for publication any suggestions regarding the use of this steel, which will tend toward its conservation.

## Pitting of Boiler Tubes and Shells

While the pitting of locomotive boiler tubes and shells has always been a source of trouble on a number of roads using bad water, some roads have found recently that the extent to which the pitting takes place has been increasing. Many mechanical department officers look on this trouble as a necessary evil and make the best of it. It is, however, high time that thorough investigations were made with a view of finding a preventive for it. Several roads, believing that it is caused by electrolytic action, have placed zinc plugs in the boiler at the washout plugs, only to find that they disappear in a day's time. On one road 33 lb. of zinc was placed in the boiler in the form of pigs, and it was entirely eaten away in fifteen days. While the experiment was not carried on for a sufficient length of time to ascertain whether the pitting decreased, it would appear that electrolysis had considerable to do with it.

Careful examination of various boilers indicates that the pitting takes place at points of the poorest circulation. It has been noted especially at the bottom of the shell just back of the front tube sheet. On the tubes the pitting seems to be the worst on the under side. That circulation has a good deal to do with it is evidenced by the trouble with the pre-heaters in the Mallet locomotives. In several cases these have had to be removed entirely, as it proved too expensive to maintain the shell and the tubes because of pitting.

Suggestions have come from some of those roads on which pitting is increasing to the effect that, due to the severe treatment received by the interior of the boiler, in order to completely

rid it of scale, the metal becomes more exposed to the ravages of the pitting agent than when a slight amount of scale is allowed to remain on the shell and tubes. Various methods for better protecting the metal have been advanced, such as copper-plating or galvanizing the tubes and painting both the shell and the tubes with a graphite paint, but the results so far have not shown that any of these methods are entirely practical.

Several roads are filling the pits in the tubes with the oxy-acetylene welding process and find that this can be done at a profit, the tubes being placed in service again. Some claim that the life of the tubes can thus be doubled and a material saving made. However, this does not offer any solution to the difficulty as far as it concerns the boiler shell, for it is against the law to do such welding on the shell.

It would appear that this problem is a subject for the chemist to analyze carefully, both from the standpoint of the water used and from the analysis of the steel or iron in the tubes and shells. We shall be glad to hear from anyone who has real live information on this subject.

### The Engine Terminal Competition

It has occurred to us that the announcement made on page 604 of the December, 1915, issue regarding the competition on Getting Results from a Big Engine Terminal, may have been misleading. It is not intended to confine the articles to practices in extremely large terminals only; what is meant is the average engine house at the average busy division terminal on any important road. Some of these terminals are better equipped, better manned, and produce better results than others. Our readers want to hear from the foremen of such engine houses as to just what methods they have pursued in obtaining results. There are, however, engine house foremen who have to contend with out-of-date equipment and more than ordinarily curtailed appropriations, and yet these men have their terminals so organized that there is comparatively little friction and locomotives are repaired and returned to service in a minimum time. There are many practices which foremen who are so situated can tell about to the advantage of others all over the country. Furthermore, some of these men, because of the difficulties with which they have to contend, have developed advanced ideas regarding the handling of an up-to-date terminal. We will give a prize of \$35 for the best article, judged from a practical standpoint, on the subject of The Handling of a Big Engine Terminal, which is received on or before February 1, 1916. Other articles which may be accepted for publication will be paid for at our regular space rates.

### Injector Steam Pipe Failures

In the annual report of the Chief Inspector of Locomotive Boilers to the Interstate Commerce Commission, which appears on another page, attention is called to the fact that accidents due to the failure of injector steam piping have increased during the past year. These failures usually result in injury—sometimes in death—to the occupants of the cab. Many of them occur at the brazing sleeve due to imperfect brazing. The brazing process is strongly entrenched because of its apparently successful use for many years, but it cannot be denied that the quality of the joint produced is uncertain. Two causes for this are mentioned in the report, and the worst phase of the whole matter is the inability to ascertain the condition of the joint by inspection. A remedy for these conditions has been pointed out. It is the so-called mechanical joint which may not only be made with certainty, but may readily be inspected to determine its exact condition. In his report, Mr. McManamy says that "as it is being adopted by many carriers and manufacturers as standard, we have refrained from recommending a rule requiring its use; but unless a reduction in accidents from failure of steam pipes at brazing sleeve can otherwise be brought about, some action in this direction will become

necessary." It is surprising that in matters of this kind where personal safety is so obviously at stake, and where it may be insured at a comparatively small expense, compulsion should be necessary to bring about the desired reduction in accidents. To have the matter clearly pointed out should be all that is necessary.

### A Competition for Apprentices

For many years this journal has consistently advocated the adoption of modern apprenticeship methods in the mechanical department. The fundamental principles upon which such a system should be based were enunciated by George M. Basford, when he was editor of the *American Engineer*, in a paper which he presented before the American Railway Master Mechanics' Association in 1905. A few years later that association adopted as recommended practice a code of principles to govern apprenticeship, which included the principles that had been advocated by Mr. Basford. Two or three large systems adopted these from the first and made excellent progress in developing strong and effective apprentice systems. Others have adopted them on a smaller scale, either in whole, or in part. As a result much greater opportunities have opened up before young men who wished to enter the mechanical department.

A few months ago we held a competition on "How Can I Help Apprentice Boys?" Few contests have excited more attention, or drawn forth so many contributions. What we should like to do now is to get some light on the other side of the question. From the standpoint of the apprentice what things that have been done for him have proved most inspiring and helpful? How have modern methods or improved practices appealed to the young man? What can be done to make the apprentice course of greater practical value?

We should like to receive a large number of letters on this subject from apprentices, or graduate apprentices who finished their courses after January 1, 1915. We don't expect elaborate essays; we don't care particularly as to whether the spelling and grammar are correct. We want the ideas—the rest can be easily taken care of.

For the best letter on the subject from a practical standpoint, which is not more than 500 words in length and which is received at our office in the Woolworth Building, New York, on or before March 1, 1916, we will give a prize of \$15. For the second best article we will give \$10. Others which may be accepted for publication will be paid for at our regular rates. Here is a splendid opportunity to convince your superiors that you are using your heads in sizing up the opportunities which are before you, and are thinking of future advancement. While you may be at the bottom of the tall ladder now, your comments or suggestions may be the means of stirring up some railroad officers to give more attention to this important problem and be helpful to many of your brothers throughout the land.

What two young men are going to head the list of the wide-awake, progressive apprentices who are capable of using their heads, and really have some ideas about training and developing of themselves for a big job? What road or what apprentice school will be honored by having the greatest number of entries in the competition?

### Systematic Promotion of Men

The greatest incentive for the workmen in the mechanical departments of our railways to leave the ranks of the wage-earners to become foremen is the opportunities they believe they have for advancement. In many cases they make a sacrifice in the matter of income when taking these positions. It is therefore imperative that every road so conduct its mechanical department that the opportunities of the minor officers form a real asset to their position. The foreman or any other officer who sees but little ahead of him cannot be expected to have a whole-hearted interest in his work. He

will be inefficient and the men under him will reflect his inefficiency in their work. Esprit de corps will be lacking.

There are several roads that make a practice of promoting their own men to fill vacancies as they occur. Other roads go outside of their forces for new men to fill these vacancies. A comparison will show that the roads following the former practice are much more efficient. Roads following the latter practice may claim that they have not men competent to fill the vacant positions. This excuse will in almost every case show their ignorance and lack of proper organization. Ignorance—because they do not know what good material they have. Poor organization—because they have not been training their men to fill the vacancies. Every man who holds any kind of office and who desires to progress should be constantly training an understudy. The department, division or shop that will carry on its daily routine in the same efficient manner with the boss away is a sign of good organization and an indication that the person in charge can be promoted without a falling off in the efficiency of his department.

The promotion of men is an extremely important matter. Departments are just as efficient as the men in charge. These men should be chosen with utmost care. The success of the entire organization is dependent on them. Some roads give this matter the consideration it deserves. In the mechanical department on one road in particular it is to be followed in a most scientific manner. Plans are being completed for a system similar to that in effect on the Lake Shore\* a few years ago, by which the men available for promotion are to be reported on by their immediate superiors periodically, these reports going to the superintendent of motive power. Ratings on some 20 items are to be made in these reports, each item being a characteristic necessary in a man who is to have responsible charge of men and important work. This provides an excellent record of the available material, insures the choosing of the best men and has a moral effect on the men themselves that is sure to show in the net results of output and efficiency. An organization thus built up will prosper and will have the strongest support of its subordinates.

**Electrification and Smoke Investigation in Chicago** The report of the Chicago Association of Commerce Committee of Investigation on Smoke Abatement and Electrification of Railway Terminals in Chicago brings the discussion of the locomotive smoke nuisance in that city down to a scientific basis, and shows, as was expected, that the air pollution and discomfort from locomotive smoke is of much less magnitude than popular sentiment has tried to make it. The report, parts of which are abstracted elsewhere in this issue, is of a most thorough, scientific and painstaking nature. It shows that by an expenditure of some \$275,000,000 the total smoke in the city of Chicago will be reduced by only five per cent net. Of all the smoke producing services investigated steam locomotives produce 22.06 per cent of the visible smoke in Chicago, ranking third among these services; and, further, inasmuch as it would be impractical to produce electrical energy for the operation of electric trains in Chicago from hydro-electric plants, steam plants would have to be installed, which would reduce the ultimate saving in smoke from locomotives to about five per cent. It is further shown that the electrification of the terminals of Chicago would be the largest undertaking of electrification in the world, and when accomplished Chicago would have a total electrified mileage greater than the present electrified mileage in the world.

While the committee believed that the electrification of the Chicago terminals was technically practical, it stated that from a financial standpoint it was impractical. The heavy expenditure required for electrification, together with the expenditure already required by city ordinances for track elevation, would place a burden on the railways entering Chicago of \$5,000 per mile of

line owned by these railways. Inasmuch as the laws would not permit the city of Chicago to participate in such an expenditure, it would have to be borne by the commerce of these railways, which if prorated over their entire mileage, would place a severe burden on many people not benefiting by the expenditure, and if this burden were placed on the traffic in Chicago the results would be disastrous to the city.

Regarding the production of smoke by the locomotives in the city of Chicago, the committee called particular attention to the work the railroads have been doing to reduce this to a minimum, and the excellent results that have been obtained. It also included in its report the results of several tests made to determine the amount of smoke, the solids and the gases emitted from the locomotives. Special tests were conducted at the Altoona testing plant of the Pennsylvania Railroad and on locomotives in yard and freight service in the district of Chicago, to determine the amount of solids emitted from the stacks at various rates of combustion. A thorough investigation was also made at the Altoona testing plant of the benefits to be derived from the use of the brick arch in locomotives, both from a fuel and smoke production standpoint. At the same time comparative tests were made with experienced and inexperienced firemen, with the same object in view. In both sets of tests coal from the various parts of Illinois and Indiana was used. Comparisons were also made between Pocahontas and bituminous coal, as regards the emission of solids from the locomotive stacks, and an investigation was made of the distribution of the solids and dust emitted from the locomotives along the right-of-way. The results of all these tests have been included in the abstract in this issue, and the methods of procedure are mentioned in a general way.

#### NEW BOOKS

*Tool Foremen's Proceedings.* Edited by Owen D. Kinsey, Secretary. 141 pages. 64 illustrations. 6 in. by 9½ in. Bound in paper. Published by the association, Owen D. Kinsey, secretary, 12323 Princeton avenue, Chicago, Ill.

This book is the report of the seventh annual convention of the American Railway Tool Foremen's Association, which was held in Chicago on July 19, 20 and 21. It contains a paper by B. W. Benedict, of the University of Illinois, on "Getting the Most Out of Tools;" a discussion on special jigs and devices, which is thoroughly illustrated; a discussion on the subject of safety first; the maintenance of pneumatic tools; grinding machine tools; distribution of machine tools; and a report of the Committee on the Standardization of Locomotive Frame Reamers. This subject has been carefully studied by the members of the association, and their recommendations represent standards that could be satisfactorily used to the advantage of both the railroads and the manufacturers.

*Mechanical Drawing.* By James D. Phillips, professor of drawing, and Herbert D. Orth, instructor in drawing at the University of Wisconsin, Madison, Wis. 283 pages. 295 illustrations. 6 in. by 9 in. Bound in cloth. Published by Scott, Foresman & Co., Chicago, Ill. Price \$1.75.

This book is for use in teaching mechanical drawing at universities, and has been arranged to give the student an appreciation of the best commercial drafting room practice while making complete, accurate and well-finished drawings of industrial projects. The book is written for students who may not have had previous experience in drawing. Each element in drawing is treated separately before the elements are combined. The general divisions are introduced in the order in which they would naturally occur in commercial drafting rooms, as follows: Prospective sketching, orthographic sketching, pencil mechanical drawing, tracing and blue printing. The problems in the book have been carefully chosen to illustrate principles of representations, dimensioning, etc., and are arranged in accordance with the principle that the more advanced the position of the problem in the course the more difficult its solution from the standpoint of both the theory and the technique.

\* See American Engineer & Railroad Journal, December, 1908, page 453.

# TWO POWERFUL 4-6-2 LOCOMOTIVES

One Class Burns Anthracite, the Other Bituminous Coal; Tractive Effort of Each Exceeds 47,000 Lb.

Two orders of exceptionally powerful Pacific type locomotives have recently been placed in service, one of five locomotives for the Delaware, Lackawanna & Western, built by the American Locomotive Company; the other an order of two loco-

## THE LACKAWANNA LOCOMOTIVES

The new Lackawanna locomotives are in service between Scranton and Hoboken. This division crosses the Pocono Mountains and has a constant ruling grade between Stroudsburg and

### COMPARISON OF RECENT PACIFIC TYPE LOCOMOTIVES EXERTING HIGH TRACTIVE EFFORT

	D. L. & W. A. L. Co.	R. F. & P. Baldwin	C. & O. A. L. Co.	C. C. & O. Baldwin	C. & O. Baldwin	B. & O. Baldwin	D. L. & W. Lima	Erie Baldwin	C. B. & Q. Baldwin	Penn Penn
Cylinders, dia. and stroke, in.....	27x28	26x28	27x28	25x30	27x28	24x32	25x28	25x28	27x28	27x28
Driving wheels, dia. in.....	73	68	69	69	73	74	69	69	74	85
Boiler pressure, lb. per sq. in.....	200	200	185	200	185	205	200	200	180	204
Heating surface, evaporating, sq. ft.	3,680	4,205	4,478.8	3,982	3,786	3,936	3,960	3,966	3,364	4,035.9
Heating surface, superheater, sq. ft.	760	975	991	955	879	833	740	879	751	1,133.0
Grate area, sq. ft.....	91.3	66.7	80.3	52.8	59.6	70	69	58	58.7	70
Weight on drivers, lb.....	197,300	188,000*	191,000	176,900	179,900	166,200*	184,600	184,300	169,700	200,000
Weight, total engine, lb.....	305,500	293,000*	312,600	280,300	282,000	263,500*	297,600	281,600	266,400	305,000
Tractive effort, lb.....	47,500	47,400	46,600	46,000	44,000	43,400	43,200	43,200	42,200	41,845

\*Weights estimated.

motives for the Richmond, Fredericksburg & Potomac, built by the Baldwin Locomotive Works. The Lackawanna engines have a tractive effort of 47,500 lb., which is the highest on record

Pocono Summit of 78 ft. per mile for a distance of 16 miles, with curves of five and six degrees. About three years ago seven Pacific type locomotives\* were built by the American Loco-

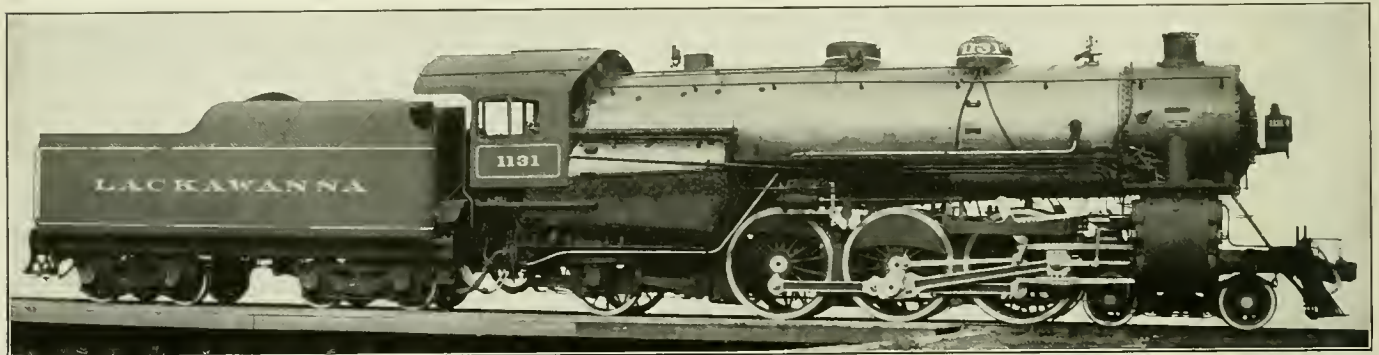

Heavy Pacific Type Locomotive for the Lackawanna

for a Pacific type locomotive. The Richmond, Fredericksburg & Potomac locomotives are but slightly less powerful, having a tractive effort of 47,400 lb. A comparison of the principal dimensions of both classes with those of several other large

motive Company, to replace a class of heavy 10-wheel locomotives than handling the through passenger service. They were designed to handle a 460-ton train over this grade at a sustained speed of 30 miles an hour and have handled trains of eight cars

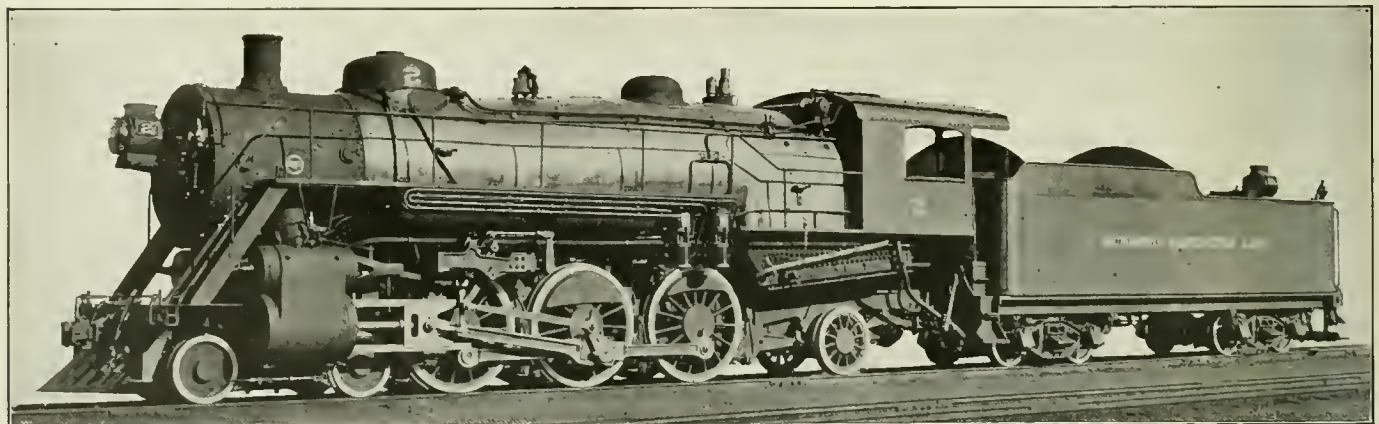

Richmond, Fredericksburg & Potomac Pacific Type Locomotive

Pacific type locomotives exerting a tractive effort of about 42,000 lb. or over, is given in the table.

weighing 530 tons at that speed. The new engines are hauling trains of nine steel cars, weighing 600 tons, under the above conditions. On other trains they are handling from one to two extra cars on schedule time on the grades, and have made it

\* For a complete description see the *American Engineer* for August, 1912, page 391.



possible to dispense with all helpers on the mountain district on trains of 10 cars or less.

The new locomotives have a total weight, engine and tender, of 471,300 lb., while the Pacifics of the older class have a total weight, engine and tender, of 449,800 lb. and a tractive effort of 40,800 lb. With an increase in weight of 4.8 per cent, an increase in tractive effort of 16.4 per cent has been obtained.

The boiler of the Lackawanna Pacific type has an outside diameter of 79½ in. at the first course, while the diameter of the largest course is 88½ in. Baffle plates are installed

The engines are equipped with the Woodard outside connected throttle\*. The throttle rod passes over the outside of the boiler jacket and in through the front of the cab. The throttle lever is arranged to provide a differential leverage. The leverage is greatest and the movement of the end of the lever is largest for a given motion of the throttle rod, when the throttle is closed. After the throttle valve is unseated the leverage increases, with a corresponding decrease in the travel of the lever handle for a given lift of the valve. In this way the travel of the lever handle in the cab may be kept within workable limits

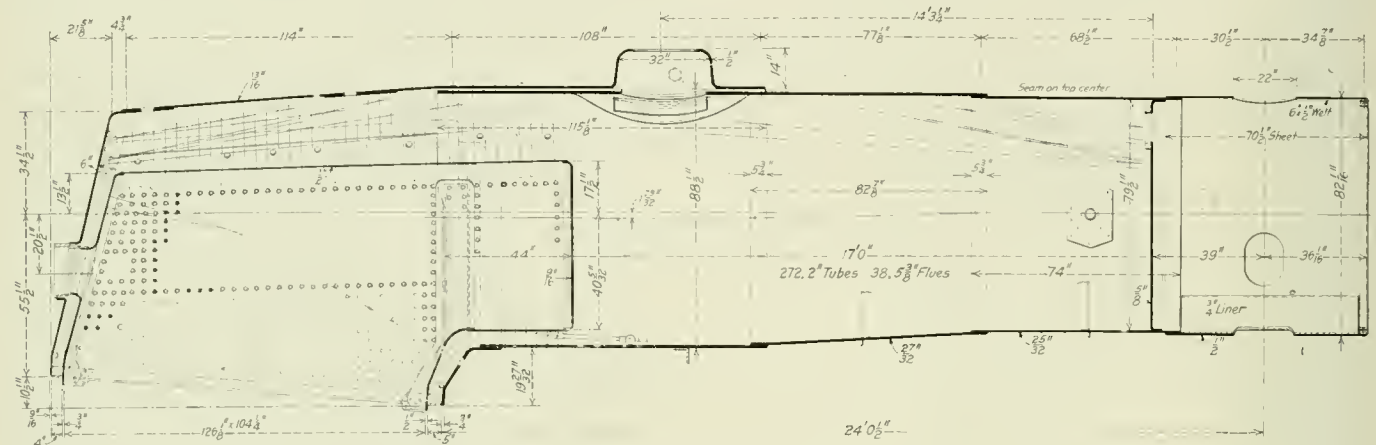

The Lackawanna Pacific Type Boiler

along both sides of the dome opening to prevent water from washing into the dome when rounding curves. All longitudinal seams are quintuple riveted. Four of the engines have a total evaporating heating surface of 3,680 sq. ft., while the other, which is provided with a Riegel boiler, has a total of 3,935 sq. ft. of evaporating heating surface.

The firebox is of the Wootten type, for burning anthracite coal, and has a grate area of 91.3 sq. ft. The general design is the same on all five engines, the Riegel firebox differing only in the application of a set of 2½-in. water tubes connecting each side water-leg with the crown. There are 38 of these tubes on each side, with a total heating surface of 260 sq. ft., which,

and a starting pull obtained sufficient to easily lift the valve.

All driving axles and main crank pins are of Cambria Coffin process steel with 3-in. holes bored the entire length after the completion of the Coffin process. The frames are of vanadium steel.

The special equipment includes Manchester-Riegel by-pass drifting valves, Walschaert direct-drive gear having the com-

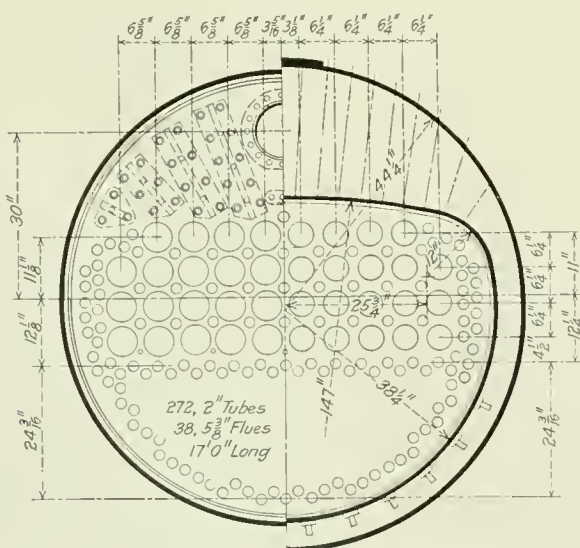

Cross Sections of the Lackawanna Boiler Showing Tube Arrangement

after deducting for the holes in the crown and side sheets, gives a net increase in heating surface of 255 sq. ft. Each firebox includes a combustion chamber 44 in. long.

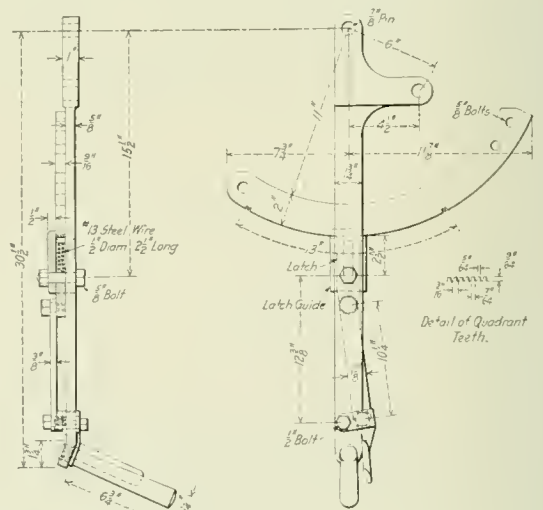

Differential Throttle Lever on the D. L. & W. Locomotives

ination link attached to the wrist pin, Schmidt superheater, Security brick arch, Ragonet power reverse gear, Fouldler solid back end main rod, Woodard inverted link, constant resistance engine truck, Cole long main driving-box, self-centering valve stem guides and radial buffer.

THE R. F. & P. LOCOMOTIVES

The Richmond, Fredericksburg & Potomac is a double-track line connecting the cities of Washington, D. C., and Richmond, Va. The distance is 116 miles, and besides local traffic, the

\*This device is described on page 48 of this issue.





road handles all the through northern connections of the Seaboard Air Line and the Atlantic Coast Line. These trains, especially during the winter tourist season, are frequently very heavy, and are hauled at an average speed, including from two to six stops, of 36 to 42 miles an hour. Including the new engines, four classes of Pacific type locomotives have been built for this service by the Baldwin Locomotive Works. Compared with the first of these, which were built in 1904, the new

The steam distribution is controlled by "Jack Wilson" piston valves, 14 in. in diameter, driven by the Baker valve gear, and the engines are equipped with the Lewis power reverse gear, furnished by the Compensating Specialties Company, Richmond, Va. Graphite lubricators are applied to the steam chests.

Special material is used quite extensively in the construction of these locomotives. The driving and engine truck axles are of heat-treated steel. Nikrome steel is used for the main and side rods, the crank pins and the cross-head pins, and Hunt-Spiller metal for the cylinder and steam chest bushings, as well as the piston and valve packing rings.

The main frames are of vanadium steel, 5 in. wide, each being cast in one piece with a single front rail, and are spaced transversely 42 in. between centers. The rear frames were furnished by the Commonwealth Steel Company, and are cast in one piece with the back foot-plate, trailing truck pedestals, radius-bar cross-tie and other projections and braces. This constitutes an elaborate casing, with an over-all length of 15 ft. 4 1/4 in. It has a slab fit in a recess formed in the main frames, and is secured to the latter on each side by 13 horizontal bolts, each 1 1/4 in. in diameter. Throughout the greater part of its length on each side this casting has a Z-section with walls 12 in. deep and 1 1/2 in. thick. A transverse brace is placed over the rear truck pedestals. The holes for the trailer truck radius-bar pin, equalizing beam pins, etc., are bushed.

The main frames are braced transversely by the guide yoke, valve motion bearer and waist-sheet cross-tie, the latter being a broad casting placed between the main and rear pairs of driving-wheels. The front and main driving pedestals are also transversely braced, the brace at the front pedestal being used as a fulcrum for the driving-brake shaft.

The rear truck is of the Rushton type, with inside journals. In this design the truck swing links are pinned to a pair of yokes which constitute part of the equalization system, the yokes being prevented from moving laterally by the truck pedestals. The pedestals on each side are fitted with renewable wearing plates 3/16 in. thick. There is no cross-connection in the driving equalization system, as the driving and truck journals are in line and the equalizers between the rear drivers and

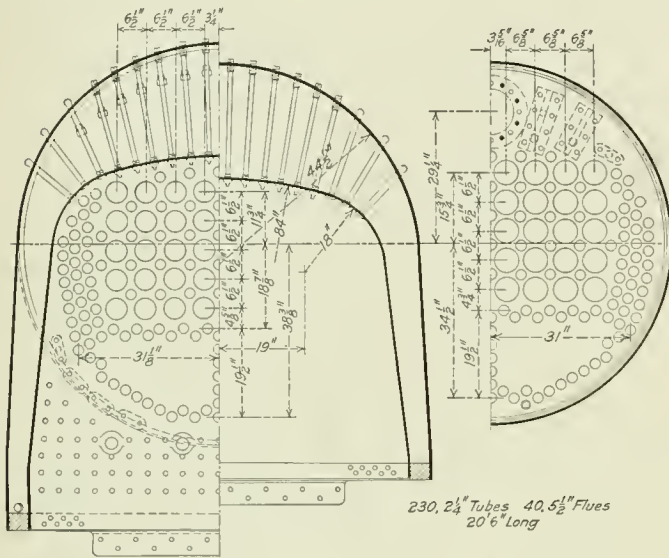

Cross Sections of the R., F. & P. Boiler

locomotives show an increase in the tractive effort of 82 per cent.

The boiler is of the extended wagon-top type, measuring 80 in. in outside diameter at the first ring and 89 in. at the dome ring. It is fitted with a one-piece pressed steel dome, measuring 33 in. in diameter by 13 in. in height. The longitudinal seams are welded at the ends and have a strength equal to 90 per cent

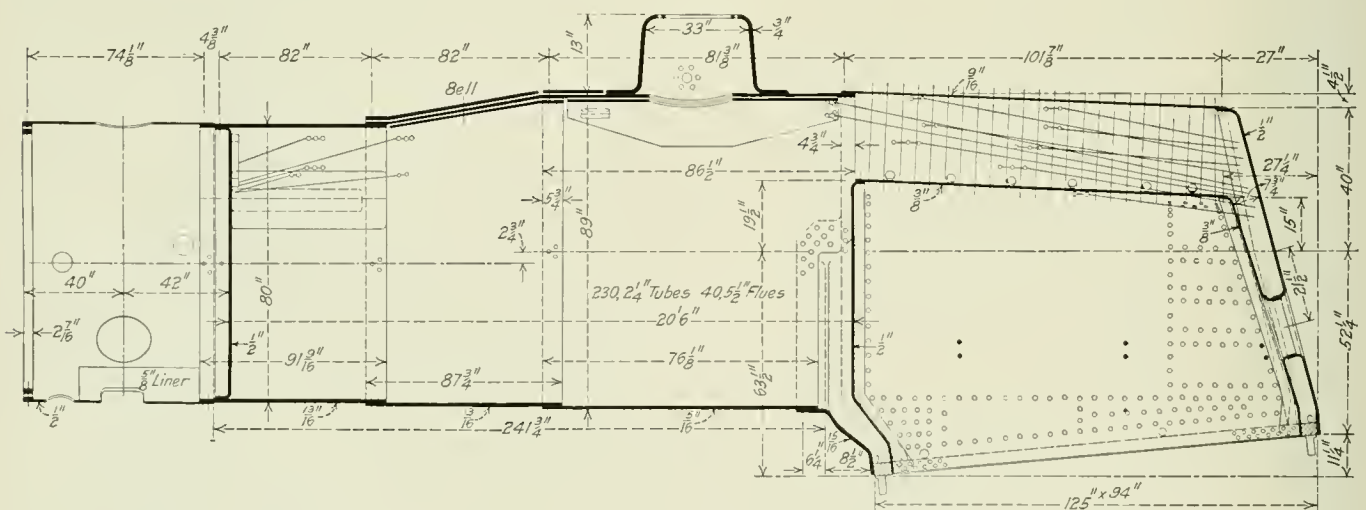

Boiler of the Richmond, Fredericksburg & Potomac Locomotive

of the solid plate. A complete installation of flexible stay bolts is used, and the front end of the firebox crown is supported by three rows of Baldwin expansion stays. The firebox is carried on expansion plates at the front and back, and the boiler barrel is supported by waist sheets at three intermediate points. A Security sectional arch, a 40-element Schmidt superheater and a Chambers throttle valve are included in the boiler equipment.

the trailer are connected directly with the spring hangers.

The arrangement of the running-boards and hand-rails is suggestive of the practice followed in certain parts of Continental Europe. The hand rails are placed outside the running-boards, the total width over the latter being 10 ft. 3 in., and a flight of steps leads from the running-boards to the front bumper.



## FAILURE OF FUSIBLE TIN BOILER PLUGS

An investigation into the failure and deterioration of fusible tin boiler plugs in service has recently been conducted by G. K. Burgess, physicist, and P. D. Mercia, assistant physicist, of the United States Bureau of Standards. In some cases such plugs have failed to melt and so give warning of dangerous boiler conditions, and investigation has shown that the tin filling in these cases had become oxidized, the tin oxide having a melting point above 2,900 deg. F.

One pronounced and dangerous type of deterioration is the oxidation of the tin along the grain boundaries, by which is formed a network of oxide throughout the tin. The plugs showing deterioration of this type all came from the same manufacturer and contained zinc in amounts varying from 0.3 per cent to 4.0 per cent. It was shown that this type of oxidation is due to the presence of the zinc. The latter metal is not soluble in the solid state in tin, and when a tin with small amounts of zinc is heated as in a boiler to about 340 deg. F. the zinc coalesces as a network enveloping the tin crystals or grains. The boiler water, particularly if it contains alkali, will attack the zinc, eating its way into the alloy along the zinc network, and finally form the oxide network described.

Lead and zinc are found to be the principal impurities in tin plug fillings, and since all failed plugs contained these or other impurities the conclusion is reached that if these impurities are eliminated by strict specifications and inspection, which will allow only admittedly superior qualities of tin, the danger of failures of these plugs will no longer exist.

## SUGGESTIONS FOR TEAM WORK IN SAVING COAL\*

*Engineers.*—The engineer can burn coal, and burn lots of it. I would ask him to pay strict attention to his fire in order to keep it bright all over the fire box, thus keeping the arch hot and keeping the flues from leaking; to work his engine as economically as he can. If you see that the fireman is getting tired, get down and shake the grates, knock over any banks and brighten up the fire to help get her hot, and if you can, dump the ash pan. And do not let the tank run over; just take enough to fill it properly. Get up on the tank and shovel over some to help get it in. I do this almost every trip. Try to get away from the water plugs as soon as the fireman is through taking water. To have the fire ready for the quick movement of a train means the saving of fuel. Drop down every time you stop and see that your sand pipes are open and working and you will save many a shovelful of coal on a hard pull. Get your engine into the yard and on the ash-pit as soon as you can, thus shortening the hours and saving coal.

*Firemen.*—I don't want to ask the firemen to do too much, but I know they can save coal if they try. First of all, keep your decks clean, as the coal falls through to the ground and many a shovelful is lost. Keep the coal back from the corners of the tank as much as you can. Fire the engine with as bright a fire as it will stand; fire light and often; keep the fire shook down, as an engine will not steam with combustion from the fire door. Watch the water in the boiler when the engineer is away. Don't let the engine pop—put in more water to help you get your fire up when the engine starts. Keep a bright fire up under the arch or under the flue sheet, for this keeps the flues from leaking and will save lots of coal.

*Brakemen.*—I want to ask the brakeman to take a wrench with him when he starts to couple up the hose. After he has gone back as far as he intends to and starts back over the train toward the engine the air will then be in the train pipe, and if he finds a small leak around a union or joint he can tighten it up, and if in a coupling, he can give it a tap and try to stop the leak,

for leaks keep the pumps running hard all the time, and it takes steam to run them and it takes coal to make steam. If he finds a brake not released, see if a retainer handle is not up, and let it down and let off all hand brakes and see that the shoes are loose. If he does this, when he gets to the engine, he will have helped to save coal.

*Conductors.*—I want to ask the conductor to help also. Every time that a train is stopped or an engine detached from a train at a coal tipple or water plug, make an effort to get over to the head end or as near as you can, and as the train pulls by bleed off any stuck brakes. If you just release one brake you will save many a shovelful of coal.

*Round House Foremen.*—I would like to see a man instructed to pay strict attention to the sanding arrangement, to see that the sand in the box is in proper condition and that the air is open from the sand-valve to the trap. I have taken pipes off and found them stopped up with rust and no air going into the trap. He should also see that the pipes are tightly clamped and in place; I have opened pipes and put them in place and the next time I stopped found them turned around out of place by the pound in side rods, the sand being blown out on the ties. If this man finds anything which causes the pipes or traps to get wet, such as branch pipes or boiler checks leaking, let him see that the leaks are stopped.

*Fire-Up Men.*—I have sat on an engine and watched the fire builder shovel coal into an engine to cover the grates, and I know that half he threw into it fell into the ash-pan and after a while was dumped over the bank. Now if he would make an effort to get down coarse coal to cover the grates and not throw in any slack until he has a fire burning, he would be the means of saving a lot of coal. I have gotten engines out with a foot and a half of unburned coal in the firebox, caused by the men crowding the fire to get the engine hot. These men could be taught to save a great deal of coal.

*Hostlers.*—I would ask them to be careful in filling tanks, to place the coal in the proper place and to take just enough to fill the tanks. The coal which falls down in the deck should be thrown back to keep coal from under the men's feet so it will not be kicked off. A machinist, fire knocker, or any other man who has to get on the engine likes to have a clean place to stand on.

*Car Inspectors.*—The car inspector comes in for his part in saving coal. If he will take a special interest in replacing any badly worn gaskets or hose and in tightening old unions, or will hold a train a few minutes while he does this work (he has the tools to do so while men out on the road have not) and put on release rods where missing, he will save many a delay on the road. I was recently on the head end of a train when a gasket in a union under the head car blew out; the union was in a bad place—probably was leaking when we started out—and the jar and working of the car caused the gasket to blow out and stopped the train. We were delayed twenty-five minutes while this was located. As nothing could be done with it, the helper held up the air from the rear until we could reach a point where the car could be set out. Please notice that two engines were burning coal during this delay.

*Operators.*—They can help by keeping a close watch on the movement of all trains and reporting to the dispatcher the approach of a train, so that orders can be gotten ready and arrangements made to keep that train in motion. I stopped at a telegraph office not long ago with orders laying on the table, and no light out, waiting on the block for fifty minutes before finding out what was delaying us. Just consider the amount of coal that was burned in that time by two engines. If only the operator had put a light out this would have been saved.

*Yard Masters.*—The yardmaster can help by having trains ready before asking for engines and having them in a place so that the crews can get to them and get out of the yard in as short a time as possible. Upon arriving at a terminal he can help us get rid of the cars and get the engines to the ash-pit without delay.

\* Part of an address by W. E. Brewer, locomotive engineer, before a Baltimore & Ohio employees' meeting.

# SMOKE AND ELECTRIFICATION IN CHICAGO

## Abstract of Report of Association of Commerce With Results of Some of the Special Investigations

The complete electrification of the Chicago railroad terminals as a means of abating smoke is technically practical, but financially impracticable. This is the finding of the Chicago Association of Commerce Committee of Investigation on Smoke-Abatement and Electrification of Railway Terminals, which has been studying the problem since early in 1911. The committee, in addition, holds that the elimination of steam locomotives alone would produce a hardly perceptible betterment of the Chicago atmosphere, and urges the appointment of a permanent Municipal Pure Air Commission which both through instruction and coercion shall reduce all sources of air pollution to a minimum.

The association committee, as a result of its painstaking investigations, reaches the following conclusions:

That the minimum cost of electrification as means in smoke-abatement would be \$178,127,230  
 That the more probable cost, due to the necessity for improvement and rearrangements, which would be precipitated by electrification, would be 274,440,630  
 That the least net annual operating deficit produced by electrification would be 14,609,743

That the Chicago electrification would equal the combined electrifications of the whole world, would involve problems never heretofore met, and would be the first ever undertaken for air betterment where terminals were adequate from an operating viewpoint.

That the steam locomotive stands third among smoke-producing services, using but 12 per cent of the fuel consumed, and that its elimination would reduce the gaseous pollution of the air only 5 per cent and the solid pollution less than 4 per cent.

That electrification, hydro-electric and other long-distance transmission being inapplicable, would add power-house smoke in quantities sufficient to offset much of the gain through elimination of locomotive smoke.

That suburban passenger services, such as those of the Illinois Central and other roads, produce but 1.54 per cent of the total visible smoke, and 1.97 per cent of all the dust and cinders.

That electrification would involve at least 3,476.4 miles of track.

That electrification would subtract only 1,291,282 tons of coal from the total of 21,208,886 tons now consumed annually in the city.

That, despite the fact that Chicago burns more coal annually than any other large city—eight tons per capita as against four for Manchester and one and one-half for Berlin—its air is better than that of most large cities.

That, in Chicago air, the products of combustion constitute only two-thirds the total pollution, the other third being due to avoidable and unavoidable dirt from the general activities of the city and from poor municipal housekeeping.

As regards the financial practicability of electrification the committee submits these findings:

"The complete electrification of the railroad terminals of Chicago as a betterment to be brought about by the railroads through the investment of free capital is, under present-day conditions, financially impracticable."

Notwithstanding the engineering difficulties that would have to be overcome in electrifying the terminals, the committee believes that these difficulties can be surmounted. Its work leads it to the conclusion that the only feasible means of electrification will be the overhead contact system or trolley. Great obstacles exist to the installation of any system, but it is believed the trolley wire more nearly meets all demands than the third rail.

### ELECTRIFICATION AND ITS COST

Thirty-eight steam railroads would be involved in the Chicago project. Twenty-five maintain passenger and freight service and 23 are classed as trunk lines, while 13 perform transfer or switching service only. It was found that the Chicago mileage would be nearly twice that of all other electrically operated mileage in America, and, exclusive of foreign light-service lines, would be about 15 per cent greater than all existing electrifications in the world. Of switching service, which constitutes 59 per cent of the total locomotive mileage and presents a grave

problem in that it has never been attempted electrically on a large scale, it has been ascertained that yard freight-switching services, on the basis of car-miles, is more than 65 times as great as that on all existing electrified steam roads in America.

In arriving at the cost of electrification, the committee based its work on 1912 operation, extended to meet conditions if electrification were to begin in 1916 and be completed in 1922. The following accounting statement shows why the committee holds that electrification is financially impossible. The deficit on the minimum outlay of \$178,127,230 would be too great:

I. ANNUAL CHARGES:	
1. Interest .....	\$8,906,362
2. Depreciation .....	7,808,278
3. Replacement of dissipated assets.....	231,796
4. Indeterminate charges .....	
Total charges .....	\$16,946,436
II. ANNUAL REVENUES:	
1. Increase in net revenues.....	\$2,336,693
2. Indeterminate benefits .....	
Total credits .....	\$2,336,693
Balance, annual deficit on investment.....	\$14,609,743

The investigations show that electrified operation for all the railroads taken together and disregarding depreciation and interest would result in a decrease in operating expenses. Under steam operation those accounts that would be affected one way or the other by electrification show a total of \$10,934,064. Under operation by the 600-volt direct-current third-rail system the total would be \$8,442,298, with the 2,400-volt direct-current system it would be \$7,355,771 and with the 11,000-volt alternating-current system it would be \$7,140,495. The installation of these three systems would result in a saving in operating expenses respectively of \$2,491,766, \$3,578,293 and \$3,793,569.

This saving, however, is in part nullified by new expenses due to the operation of stations that would have to be established at the end of electrified tracks to provide for a transfer of trains from electric to steam locomotives, and also by the waste and consequent loss due to operating over shortened steam railroad divisions, which have surrendered part of their mileage to make the new terminal electric divisions.

### AIR POLLUTION

As a result of its investigation into air pollution the committee finds that one-third comes from sources other than combustion. The air is filled with vegetable, animal and mineral matter which rises from the various activities of the city. Table I shows the standing of the various services investigated as to air pollution.

TABLE I.—RESPONSIBILITY OF EACH SERVICE FOR SMOKE POLLUTION WITHIN CHICAGO, ON PERCENTAGE BASIS

	Visible smoke per cent	Solids of smoke per cent	Total of smoke per cent	Gaseous carbon per cent	Gaseous sulphur per cent
Steam locomotives.....	22.06	7.47	10.31	10.11	18.22
Steam vessels.....	0.74	0.33	0.60	0.55	0.45
High pressure steam stationary power and heating plants.....	44.49	19.34	44.96	40.68	53.70
Low pressure steam and other stationary heating plants.....	3.93	8.60	23.00	23.06	19.73
Gas and coke plants.....	0.15				
Furnaces for metallurgical, manufacturing and other processes.....	28.63	64.26	21.13	25.60	7.90

One-third of all air pollution is due to dirt other than that of combustion. These percentages refer to the remaining two-thirds.

In its study of air pollution the committee states that even the comparatively small reduction to be expected from electrification is made less significant when it is recollected that substantial progress in recent years has been made in reducing the smoke from locomotives in Chicago. There is every reason to

believe also that the process has not yet reached its maximum. The improvement has resulted both from embellishments in locomotive design and from the exercise of greater skill in operation. The report states:

"Among the more important changes in design which have aided in smoke abatement are the enlargement of grates, which has resulted in lower rates of combustion per unit area of grate, and consequently in a reduction in the amount of solids in locomotive smoke; the adoption of the brick arch in locomotive fire-boxes, by means of which a reduction in the amount both of visible smoke and of the solid constituents of smoke has been effected; the more efficient design of draft appliances, by which the air currents stimulating the fire have been modified and smoke production diminished; the introduction of superheaters, whereby the efficiency of the locomotive as a whole has been increased, the amount of fuel required for the performance of a given service diminished and the volume of smoke diminished; and the introduction of steam jets and other appliances especially designed to diminish visible smoke.

"Meanwhile, the amount of smoke emitted within the city has been greatly reduced through the exercise of diligence and skill in the operation of locomotives. The importance given this aspect of the matter by the railroads of Chicago is to be seen

TABLE II—CONTRIBUTIONS MADE BY STEAM LOCOMOTIVES TO THE POLLUTION OF THE ATMOSPHERE OF CHICAGO

Service	Fuel consumption per cent	Visible smoking per cent	Solids in smoke per cent	Gases in smoke per cent
Yard.....	5.97	10.25	1.73	5.17
Road freight.....	0.77	2.01	1.18	0.66
Freight transfer.....	2.02	4.59	0.43	1.74
Passenger transfer.....	0.12	0.19	0.04	0.10
Through passenger.....	1.01	2.07	1.80	0.89
Suburban passenger.....	0.88	1.54	1.97	0.74
Locomotive terminals.....	1.17	1.41	0.32	1.01
All other classes of smoke producers	88.06	77.94	92.53	89.69

in the number of smoke inspectors which they have employed."

Table II gives the relative information concerning the importance of the various classes of steam locomotives as a source of smoke.

METHOD OF MEASURING SMOKE

In the committee's investigation in determining the relative density or visibility of the smoke the Ringelmann method was employed. In computing the smoke density for a number of stacks or for those of an entire service or district the observed results are reduced to unit values, the value of one stack for a period of one minute being termed a "stack minute," and the emission of No. 1 smoke for one minute, or its equivalent, being termed a "smoke unit." By employing these unit values the percentage of density as measured by the Ringelmann scale may be computed by means of the following formula:

$$\text{Percentage density} = \frac{\text{Smoke unit} \times 20}{\text{Stack minutes}}$$

In the development of the committee's investigation with reference to the visible properties of smoke a corps of from 16 to 20 trained smoke inspectors under the supervision of a chief inspector were engaged in making observations of smoke density from April 22, 1912, to March 14, 1913. Observations of smoke from locomotive smoke stacks were made at each railroad yard, at each locomotive terminal, and at various points along each line of railroad within the area of investigation. This area extends to include Evanston, Ill., on the north, to Gary, Ind., on the south, the western boundary passing through Harvey, Blue Island and La Grange, Ill. The whole area was divided into two zones, A and B, the former including the city of Chicago and the latter the territory outside the city limits. The records show that 10,653 observations were made of smoke emissions from steam locomotives in railroad yards and at points on the line, and that 1,323 observations were made of smoke emissions from locomotives at terminals, a total of 11,976 observations. It

was found that more smoke was produced, or rather, the average density of the smoke was greater, in the outer zone, Zone B, than in the inner zone, the latter including the most congested part of the area of investigation. The average density for Zone A was 15.30 and for Zone B, 23.17, making an average of 16.79. The road freight locomotives gave the greatest trouble, the average density in Zone A for this class of locomotive service being 25.32, and in Zone B, 26.91.

SOLID CONSTITUENTS OF STEAM LOCOMOTIVE SMOKE

Information concerning the solid constituents of locomotive smoke has been derived from two series of investigations made by the committee in which the solids discharged from the smoke stack were measured. These embrace service tests conducted in connection with locomotives operating in yard and transfer service within the area of investigation, and laboratory tests conducted in connection with a locomotive mounted on a testing plant and supplemented by tests on locomotives operating in through passenger, through freight and suburban services in the area of investigation, to determine rates of combustion. By means of special apparatus all or a known portion of the solid emissions from the smoke stack were caught and deposited in an arrester from which they could be collected for analysis. The samples were classified as follows:

*Coarse Cinders*—Solid particles which remain upon a coarse sieve of 20 meshes to the inch (400 apertures per square inch).

*Fine Cinders*—Solid particles which pass through the coarse sieve and remain upon a fine sieve of 200 meshes to the inch (40,000 apertures to the square inch).

*Fuel Dust*—Solid particles which pass through the fine sieve.

The road tests were conducted with suitable apparatus for obtaining a known proportion of the cinders emitted from the stack.

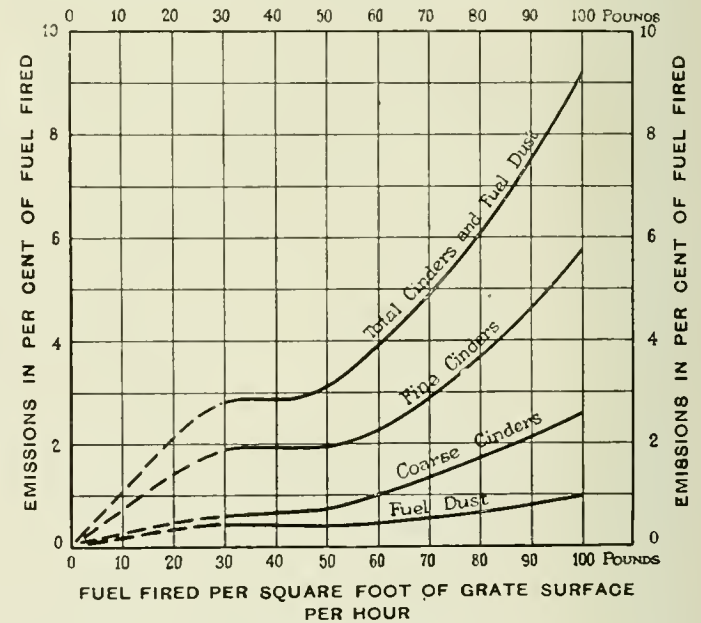

Amount of Solid Constituents of Smoke Emitted by a Locomotive on a Testing Plant

A record of the number of scoops of coal fired was taken, the average weight of a scoopful of coal being ascertained by experiment, and with this information the relation between the solid constituents of locomotive smoke and the fuel consumed was established. Forty-one tests were conducted on steam locomotives operating in yard and transfer services of Chicago terminals. Bituminous coal was used for some of these tests and Pocahontas coal for others.

Since any method which could be satisfactorily applied in service was found impracticable for determining the amount of solid matter contained in smoke arising from locomotives while operating at high speed, data relating to the amount of solids emitted in smoke at various rates of combustion was secured

by means of a series of tests conducted at the locomotive testing laboratory of the Pennsylvania Railroad at Altoona. The locomotive used in all laboratory tests was a Consolidation freight locomotive of the Pennsylvania type H-8-B, weighing 238,300 lb. The coal for the test was typical of that used by the railroad entering Chicago. The locomotive firebox was equipped with a brick arch and all tests were conducted with the throttle fully open, the speed being controlled by the load. A total of 76 tests were made. The maximum rate of combustion for each sample of fuel tested was more than 80 lb. per square foot of grate surface per hour, and in all except two cases was more than 100 lb. per square foot of grate surface per hour. The minimum rate of combustion for the several coals varied from 23 to 27 lb per square foot of grate surface per hour. The accompanying diagram shows the percentage of the fuel burned which appears as solids in the smoke as averaged from all the tests made. It is shown by this diagram that the amount of solids emitted in smoke is a function of the rate of combustion. To establish these rates of combustion attending the normal operation of locomotives in through and suburban services in Chicago a series of 298 tests was made on locomotives operating within the area of investigation. The rate of fuel consumption was found by counting the scoops of coal fired, the value of the average scoopful having been carefully determined. The grate area of each locomotive was obtained from the railroad and all the rates of combustion determined. These were found to be for the several services involved, as follows:

Service	Lb. per sq. ft. grate surface per hour	Per cent of fuel fired while running
Road freight.....	40.6	92.7
Through passenger.....	52.2	98.2
Suburban passenger.....	62.7	96.4

By combining these rates of combustion with the values for the emission of cinders as set forth in the diagram, and by multiplying the values ascertained by the percentage of fuel fired while running, the emission factors for solids emitted by locomotives operating within the area of investigation were established.

TABLE III.—EMISSION FACTORS FOR SOLID CONSTITUENTS OF STEAM LOCOMOTIVE SMOKE

Service	Kind of fuel	Solids in lb. per ton of fuel burned				Solids in per cent of fuel burned			
		Coarse	Fine	Dust	Total	Coarse	Fine	Dust	Total
Yard.....	Pocahontas.....	1.30	9.72	24.54	35.56	0.065	0.486	1.227	1.778
Yard.....	Bituminous.....	0.76	3.42	5.24	9.42	0.038	0.171	0.262	0.471
Road freight.....	Bituminous.....	11.30	34.68	6.86	52.84	0.565	1.734	0.343	2.642
Freight transfer.....	Pocahontas.....	1.84	7.92	19.64	29.40	0.082	0.396	0.982	1.470
Freight transfer.....	Bituminous.....	0.62	2.16	4.46	7.24	0.031	0.108	0.223	0.362
Passenger transfer.....	Pocahontas.....	1.30	9.72	24.54	35.56	0.065	0.486	1.227	1.778
Passenger transfer.....	Bituminous.....	0.76	3.42	5.24	9.42	0.038	0.171	0.262	0.471
Through passenger.....	Pocahontas and bituminous.....	15.08	39.40	7.84	62.32	0.754	1.970	0.392	3.116
Suburban passenger.....	Bituminous.....	20.54	47.42	9.26	77.32	1.032	2.371	0.463	3.866

The emission factors for solid constituents of locomotive smoke thus determined, and also those for yard and passenger service, as determined by use of the cinder arrester in service tests, are presented in Table III.

SPREAD OF SOLID MATERIALS IN THE SMOKE OF LOCOMOTIVES

For the purpose of ascertaining the facts concerning the physical properties of particles emitted, and the distance traversed by them, an extensive series of tests was undertaken and conducted by the committee. These tests were conducted throughout the two zones of investigation, both in the switching yards and on the main lines of the railroad. Of the total number 64 were conducted in Zone A and 36 in Zone B. A series of 10 galvanized iron pans, each 18 in. square and 6 in. deep, constituting an open receptacle with an area of 2.25 sq. ft., were placed at definite distances on the lee side of the track. The average duration of each test was 5.5 hours. The total amount of the cinders caught were computed, and further divided as coarse and fine cinders, fuel dust, inorganic matter and organic matter, the last two being deposited in the pans due to the suction created by the train and not from the locomotive. The average amount of each which were deposited in each pan is shown in Table IV.

PERFORMANCE OF ILLINOIS AND INDIANA COAL

The following is a more detailed description of the test made by the committee on the Consolidation locomotive at the testing

TABLE IV.—AVERAGE AMOUNT OF EACH CLASS OF SOLIDS DEPOSITED IN PANS, PER CENT

Pan	Dis- tance	Place	Zone	Per Cent Cinders from locomotives			Matter not from locomotives
				Coarse	Fine	Dust	
1	20 ft.	Yards.....	A	58.03	31.40	2.98	4.59
			B	19.86	22.85	12.12	45.17
		Main line...	A	57.55	24.68	4.51	13.26
			B	51.62	25.25	1.82	18.31
2	40 ft.	Yards.....	A	57.16	35.75	2.60	4.49
			B	45.66	22.25	9.99	24.10
		Main line...	A	62.63	25.91	4.35	6.11
			B	56.02	28.25	1.86	13.87
3	60 ft.	Yards.....	A	62.84	30.88	2.16	4.12
			B	51.98	22.30	6.46	16.26
		Main line...	A	58.54	28.06	5.50	7.90
			B	59.11	26.23	1.92	12.71
4	80 ft.	Yards.....	A	65.08	29.19	2.11	3.62
			B	56.86	29.01	2.95	11.15
		Main line...	A	54.24	36.27	5.08	4.41
			B	52.02	32.28	2.93	12.77
5	100 ft.	Yards.....	A	62.10	27.69	3.16	7.05
			B	51.05	28.20	2.47	18.28
		Main line...	A	47.54	36.56	7.26	8.64
			B	34.63	24.04	9.93	31.40
6	125 ft.	Yards.....	A	45.41	34.14	4.20	6.25
			B	9.81	11.65	3.91	74.63
		Main line...	A	43.00	38.71	8.32	9.97
			B	33.15	31.59	17.30	17.96
7	150 ft.	Yards.....	A	52.77	37.49	3.66	6.08
			B	21.38	23.70	7.57	17.35
		Main line...	A	42.37	36.65	8.55	12.43
			B	35.11	34.80	5.56	24.53
8	200 ft.	Yards.....	A	35.53	46.54	6.02	11.91
			B	12.29	24.81	14.78	48.12
		Main line...	A	39.90	28.61	8.28	20.11
			B	26.74	36.76	7.84	28.66
9	250 ft.	Yards.....	A	21.34	37.28	13.08	28.30
			B	19.11	22.44	7.14	51.31
		Main line...	A	30.97	33.98	9.84	25.21
			B	10.81	20.07	3.89	65.23
10	350 ft.	Yards.....	A	30.76	47.77	9.56	11.91
			B	9.82	22.73	11.15	56.30
		Main line...	A	20.92	32.66	12.40	34.02
			B	14.34	27.57	6.13	51.96

plant of the Pennsylvania Railroad at Altoona. The tests were planned for the prime purpose of establishing facts with reference to the smoke discharges of steam locomotives, and to show also the value of the brick arch in the locomotive firebox as

a factor promoting economy in the use of fuel, a reduction of cinders and fuel dust in smoke, a reduction of the density of visible smoke, reduction of loss of heat units in smoke and ash discharges, and boiler efficiency. The value of experience in locomotive firing as a factor in promoting economy of fuel consumption, a reduction of cinders and fuel dust in smoke, a reduction in the density of visible smoke and in boiler efficiency was also considered.

A total of 75 tests were made, in 56 of which the locomotive firebox was equipped with a brick arch and in 19 the arch was removed. Sixty-four tests were made with experienced firemen and 11 were made with inexperienced firemen. The coals selected for this series of tests were representative of the coals burned in locomotives operating in the Chicago terminals. Coals were obtained from the following 10 counties: Macoupin, Ill.; Marion, Ill.; Saline, Ill.; Sangamon, Ill.; Vermilion, Ill.; Williamson, Ill.; Greene, Ind.; Sullivan, Ind.; Vermilion, Ind., and Vigo, Ind. The coal from Saline, Ill., has an average heat value of 13,247 B.t.u., while the other nine varied between 11,227 and 11,919, with an average of 11,598 B.t.u. per lb. In Table V are given the general averages obtained from these tests. They are divided into three classes. The first class is an average of the ten coals,

fired with a brick arch; the second gives the results of the coal from Macoupin, Ill.; Williamson, Ill.; Sullivan, Ind., and Ver-

TABLE V.—AVERAGE RESULTS OF THE ALTOONA TESTS.

Group*	BA—10	NA—4	BA—4
Equivalent evaporation per pound dry coal (lb.)	9.3	8.6	9.2
Boiler efficiency (per cent)	67.7	63.4	67.2
Dry coal per dynamometer horsepower hour (lb.)	4.3	4.6	4.3
Smoke densities (per cent)	23.6	36.5	24.1
Cinders and fuel dust (per cent of fuel fired)	4.56	5.56	4.18
Carbon contained in the cinders and fuel dust (per cent of fuel fired)	3.11	3.79	2.88

\*BA—10 = Average of 10 different coals with the brick arch.  
 NA—4 = Average of 4 different coals without the brick arch.  
 BA—4 = Average of 4 different coals with the brick arch.

million, Ind., without the brick arch; while the third gives the results of these same coals with the brick arch.

From the results of these tests the following summary of the advantages of the brick arch in the firebox were determined:

Increases in number of pounds of water evaporated per pound of coal from 8.6 to 9.2.

Increases of boiler efficiency from 63.4 per cent to 67.8 per cent.

Decrease in the amount of coal consumed per dynamometer h.p.-hour from 4.6 lb. to 4.3 lb.

Decrease in average density of visible smoke emissions from 36.5 per cent to 24.1 per cent.

Decrease in the total average quality of cinders and fuel dust emitted in smoke from 5.56 per cent to 4.18 per cent of the fuel fired.

Decrease in the number of heat units per pound of cinders in fuel dust emitted in smoke from 9,610 B.t.u. to 9,064 B.t.u.

Decrease in the amount of carbon contained in cinders and fuel dust per ton of coal consumed, from 75.8 lb. to 57.6 lb.

Decrease in the number of heat units contained in the ash and clinker discharges per pound of fuel fired, from 6.28 to 4.98.

Decrease in volume of air intermingled with the gases of combustion, discharged through the stack, from 26.5 per cent to 22.5 per cent.

Increases of the portion of the carbon in the fuel which combines with oxygen to form carbon dioxide, from 51.1 per cent to 53.2 per cent.

Table VI gives the results obtained with experienced and with inexperienced firemen operating the locomotive at 80 revolutions

TABLE VI.—RESULTS OF TESTS WITH EXPERIENCED AND INEXPERIENCED FIREMEN.

Test Group*	BA—9—E	BA—9—I	NA—2—E	NA—2—I
Dry fuel fired per sq. ft. grate surface per hr., lb.	46.1	57.5	51.5	55.6
Equivalent evaporation per sq. ft. H. S., per hour	7.1	7.2	7.0	7.1
Equivalent evaporation per lb. dry coal	9.7	8.0	8.6	8.2
Boiler horsepower	700.4	707.7	684.7	711.0
Efficiency of boiler based on fuel per cent	73.2	59.7	65.2	62.7
Dry fuel per dynamometer h.p. hr., lb.	3.9	5.2	4.3	4.6
Thermal efficiency of locomotive based on fuel, per cent	5.0	3.9	4.7	4.5
Average smoke density, per cent	18.	36.	27.	31.
Cinders and fuel dust in per cent of fuel fired	3.44	4.00	2.37	2.98

\*BA—9—E = Average of 9 different coals with the brick arch and experienced firemen.

BA—9—I = Average of 9 different coals with the brick arch and inexperienced firemen.

NA—2—E = Average of 2 different coals without the brick arch and with experienced firemen.

NA—2—I = Average of 2 different coals without the brick arch and with inexperienced firemen.

†One boiler horsepower = 34.5 lb. equivalent evaporation per hour.

per minute and at 25.6 per cent cutoff, burning coal with and without the brick arch in the firebox. The first column is an average of the coals obtained from Marion, Saline, Sangamon, Vermilion and Williamson counties, Ill.; and Greene, Sullivan, Vermilion and Vigo counties, Ind. The last two columns in the table consider the coal from Macoupin and Williamson counties, Ill.

When burning the same kinds of coal in a locomotive firebox equipped with a brick arch, firing by inexperienced firemen, as compared with that by experienced firemen, results in the following:

An increase in fuel consumption from 46.1 lb. to 57.5 lb. of fuel fired per sq. ft. of grate surface per hour.

An increase in boiler horsepower from 700.4 to 707.7.

A decrease in boiler efficiency from 73.2 per cent to 59.7 per cent.

An increase in fuel consumed per dynamometer horsepower from 3.9 lb. to 5.2 lb.

An increase in smoke density from 18 per cent to 36 per cent.

An increase in cinders and fuel dust discharged in smoke from 3.44 per cent to 4.00 per cent of the fuel fired.

A decrease in thermal efficiency from 5.0 to 3.9 per cent.

A similar comparison of the values obtained when firing the same kinds of coal in a locomotive firebox not equipped with a brick arch shows that firing by inexperienced firemen results in the following:

An increase in fuel consumption from 51.5 lb. to 55.6 lb. of fuel fired per sq. of grate surface per hour.

An increase in boiler horsepower from 684.7 to 711.0.

A decrease in boiler efficiency from 65.2 per cent to 62.7 per cent.

An increase in fuel consumed per dynamometer horsepower from 4.3 lb. to 4.6 lb.

An increase in smoke density from 27 per cent to 31 per cent.

An increase in cinders and fuel dust discharged in smoke from 2.37 per cent to 2.98 per cent of the fuel fired.

A decrease in thermal efficiency from 4.7 per cent to 4.5 per cent.

ELIMINATION OF SMOKE AT TERMINALS

As a means of eliminating smoke at engine terminals, round-houses, etc., the committee referred to various smoke washing devices, calling particular attention to the smoke washing plant of the New York Central at its Englewood roundhouse in Chicago. This plant was described in the *Railway Age Gazette, Mechanical Edition*, for October, 1915, page 511. Referring generally to the smoke washing process, the committee said: "The possibilities of the process have long been understood. Its application has been retarded by difficulties encountered in maintaining the plant in the presence of the corrosive acids developed by the process, and by operating costs arising from the consumption of water and power." Smoke washing as a process of general application is still in an experimental stage. Enough has been accomplished to prove that by means of it practically all the objectionable elements in smoke can be suppressed.

The precipitation of suspended matter and gases may also be accelerated by electrical means. If the products of combustion are made to traverse an electrostatic field, the solid particles may be intercepted. This principle has been employed in the removal of solids from the gases of metallurgical and other industrial furnaces. A few applications have been made in connection with the furnaces of boiler plants; the approaching soot or dust particles responding to electrical influences, attach themselves to the grating as do metallic particles to a magnet. The grating is cleaned by interrupting the current. The New York Edison Company has experimented with this process as a means for the suppression of fuel dust and ash from the stack of one of its stations.

The committee was appointed in March, 1911, and consisted of four members appointed by the mayor, four appointed by the railroads and nine appointed by the Chicago Association of Commerce. The late Horace G. Burt was chief engineer for the committee until May, 1913, and was succeeded by W. F. M. Goss, dean of the Engineering Department, University of Illinois. The report was submitted to the association at a dinner on Wednesday evening, December 1.

INSULATION STRENGTH OF OIL.—The insulation strength of the oil in all transformers used on circuits operated above 6,600 volts in the system of the Georgia Railway & Power Company, Atlanta, Ga., is tested once each month. When the oil shows an insulation strength lower than 40,000 volts it is filtered and tested until this strength is secured. It is well known that a small amount of moisture in oil greatly reduces the insulation strength, and inasmuch as a small sample must be taken for test, it has been found that extreme care must be exercised to secure and deliver the sample to the test room in the same state as that in which it is found in the transformer case. To make this possible a specially prepared 4-oz. sample bottle is furnished to station operators for delivering the monthly samples for test. These bottles are prepared by washing and rinsing in petrol, then dried and the corks inserted. The cork and mouth of the bottle are then dipped in heated paraffin, which seals the bottle air-tight.—*The Engineer*.



# OPERATION OF RADIAL COUPLED AXLES\*

## Methods of Driving Articulated Systems from a Single Set of Cylinders; Future Possibilities

BY ANATOLE MALLET, Paris, France

In locomotive construction, it is often necessary to introduce, at one or both ends, carrying axles with radial play, in order to facilitate the handling of curves. Such construction reduces, however, the amount of adhesive weight. Hence, for a long time, arrangements have been sought which would make it possible to transmit power to convergent axles without increasing the number of steam cylinders. These various systems of transmission may be divided into two classes: Those which involve elements having rotary motion; and those which involve elements having reciprocating motion.

### TRANSMISSION BY ROTARY MOTION

This class includes gear transmission, transmission by endless chain and transmission by universal joints.

Gear transmissions appear to have been first utilized for operating locomotive axles having freedom of radial movement in 1838, in a locomotive built at Heath Abbey for the Rhymney

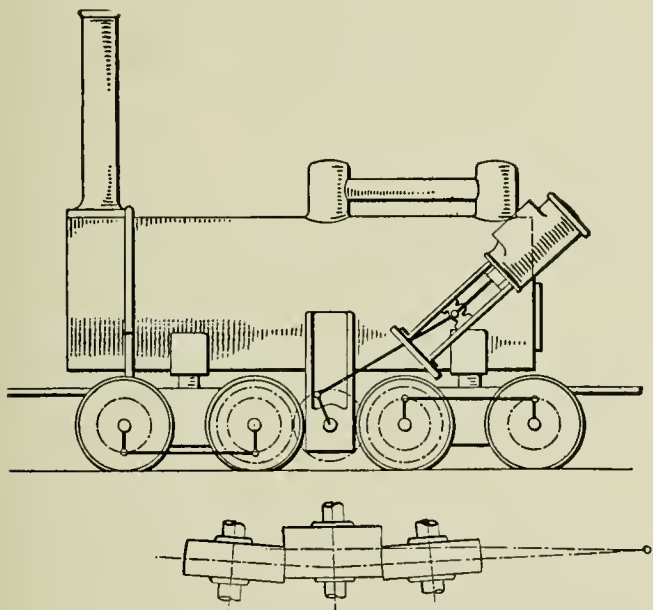

Fig. 1—Gear Transmission Locomotive

foundry in Wales. This locomotive was carried on two trucks with two axles each, as shown in Fig. 1, which is reproduced from *The Engineer*, November 15, 1867. The two trucks could turn so that they were at an angle with each other without throwing the driving gears out of mesh.

In 1841, the Baldwin Locomotive Works built a locomotive in which the rear axles were driven by means of a countershaft and connecting rods, and the axles of the front truck were operated by a gear transmission located on the longitudinal axis of the machine. This locomotive weighed 13½ tons and was designed for use on a quarry railroad. The results were satisfactory, but the type was afterwards abandoned.

The French engineer, Tourasse, presented at the Competition of Semmering in 1851 a design of locomotive with six axles similar to the Rhymney locomotive. This locomotive was to weigh 60 tons with the water carried in a saddle tank on the boiler. The power developed would have been extraordinarily large for that time, since, according to the author of

the design, the locomotive was to be able to start with a load of 250 tons over a grade of 2½ per cent. The Locomotive Works of Winterthur, Switzerland, built in 1883, for an industrial railroad in the south of France, a locomotive similar to the one just described. It appears that this type was unsuccessful.

The famous Engerth locomotive built after the Semmering Competition, from which no practical results were obtained,

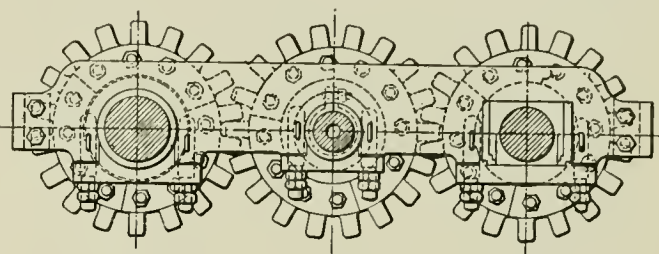

Fig. 2—Gear Arrangement in the Engerth Locomotive

was at first characterized by the use of gear transmission for connecting the last axle of the locomotive to the forward axle of the tender. The arrangement of these gears is shown in Fig. 2. The intermediate shaft, carrying the middle toothed

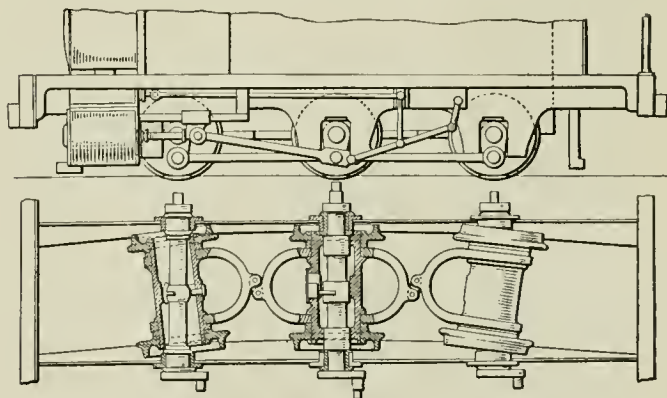

Fig. 3—Haywood's Hollow Axle Locomotive

gear is arranged to slide longitudinally in its bearings, if necessary, to cut out the connection with the wheels of the tender. Quite a large number of Engerth locomotives were built. As the gears did not give satisfactory results in actual practice,

\*Abstract of a paper presented at the annual meeting of the American Society of Mechanical Engineers in New York, December 7-10, 1915.

however, they were eliminated and the complicated gear transmission type has long since entirely disappeared from practice.

Before 1830, W. N. James, of Birmingham, proposed to connect not only the axles of the locomotive and tender but also those of the cars by means of gear wheels operated by a longitudinal shaft running the length of the train and provided with ball and socket joints to give them the flexibility necessary for making the curves. The locomotives of the Climax, Shay and Heisler systems use this principle, the Climax and Heisler locomotives having been actually built in sizes of 75 to 80 tons and the Shay locomotives, up to 135 tons.

The use of endless chain for coupling axles which may be thrown out of parallelism appears to have been adopted for

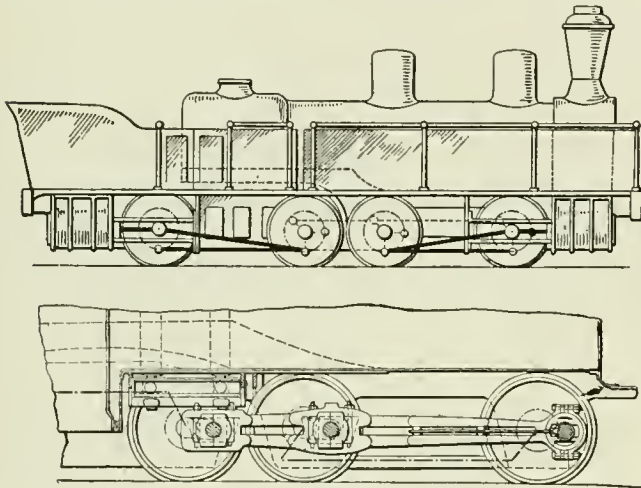

Fig. 4—Central Connecting Rod Arrangement Designed by Société John Cokerill

the first time in 1851, by S. A. Maffei, of Munich, in the construction of the locomotive Bavaria, presented by him at the Semmering Competition. This machine had seven axles, driven by two cylinders. The axles were divided into three groups and the wheels of each group were coupled by external connecting rods, while the groups were connected by endless chains made of links and studs. The engine was given the first prize at the competition. It was said that the victory was due only to the very brief duration of the tests, and that this locomotive could be maintained in good operating condition only by constant repairs to the chain transmissions. As a matter of fact, the Bavaria has never been reproduced in full or in part.

Lievesey, in 1860, devised an arrangement of chains and sprockets, not mounted directly on the axles, but carried on a spherical ball joint in such a manner that the toothed wheels and chains remain always in the same plane. In the United States a type of small locomotive designed to operate over roads made of logs placed end to end is sometimes used in lumbering operations. This locomotive is set on two trucks and its axles are driven by means of chains from a countershaft operated by the cylinder. The wheel treads are groove-shaped, fitting over the log rails on which they run.

The transmission by universal joints may be considered as including all transmissions by ball joints. The term ball joint applies here to any device involving wheels mounted on a hollow axle, in the interior of which is a shaft that receives the power from the steam cylinders and transmits it by means of a ball joint, or universal joint, to the hollow axle. On curves the hollow axles take the radial displacement while the interior shafts remain parallel. The hollow axles are coupled by external rods in such a manner as to make the converging movements of the outer axles and the movement of the transverse displacement of the central axle correspond. This ingenious device appears to have been invented by Percival Haywood, who made use of it about 1880 on a small locomotive running on a 15-in. gage

railroad having curves of 16-ft. radius. This transmission is shown in Fig. 3.

E. P. Cowles applied the same principle, but a different arrangement, to a locomotive on a quarry railroad in Kentucky. Only the central carrying axle of each truck was hollow, containing a rigid shaft acted upon by the steam cylinders. The other axles were coupled by external connecting rods, in the middle of each of which was provided a slot for the crank pin of the fixed shaft, which is carried on external supports and is connected with the hollow axle by a central universal joint. The inventor utilized the peculiar idea of operating both trucks from the same cylinders in order to simplify the general construction of the machine. To accomplish this, each piston rod was arranged to pass through both covers of its cylinder and to engage at each end with a connecting rod. Due to the obliquity of these connecting rods, however, their midpoints of stroke did not correspond to each other, and a sliding of the wheels twice in each revolution resulted.

#### TRANSMISSION BY RECIPROCATING MOTION.

The mechanisms of this class may be divided in the following manner: Coupling of convergent axles by connecting rods located in the longitudinal axis of the engine, these connecting rods being either simple or double, rectilinear or triangular; coupling by oscillating levers or equalizers; use of a free axle coupled by connecting rods to the converging axles, and coupling of axles by means of external connecting rods of which the length varies with the radial displacement of the axles.

The use of central connecting rods acting on spherical crank pins located in two contiguous axles is a very simple idea, but there is serious difficulty in passing the dead center. This can be remedied in several ways. Fig. 4 shows a design of locomotive presented by the Société John Cokerill to the Semmer-

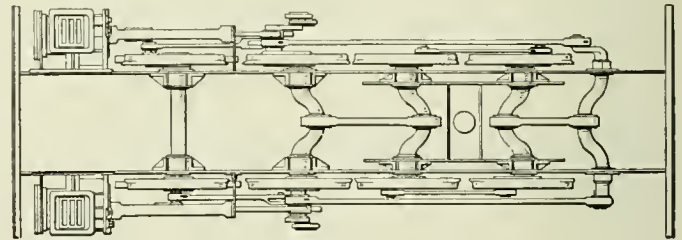

Fig. 5—Aliges' Four-Axle Locomotive

ing Competition. In this design two cylinders act on the two front axles while two other cylinders act on the two axles of the truck in the rear. The first axle of this truck is coupled to the two axles of the engine by a central connecting rod engaging with three axle cranks. This design is referred to here because of the arrangement of center coupling. It has never been put into practice.

Thouvenot took up the idea of locating rods on the axis of engine about 1860. He deflected the connecting rods so as to bring them back into the axis of the engine, the crank-axles being so designed as to bring both cranks on the longitudinal center line. This arrangement does not appear to possess sufficient strength.

C. Aliges, former engineer of the Cail factory in Paris, developed a design for a four-axle locomotive (Fig. 5), in which one of the two axles forming the truck was connected with the driving shaft by a central connecting rod and the other with the third axle by a like arrangement.

The idea of using oscillating levers for coupling convergent axles was first disclosed about 1855 in an invention by Lucien Rarchaert. There is a model of this arrangement in the gallery of the Conservatoire des Arts et Métiers in Paris, but the system itself has never been actually used.

A German engineer, Christian Hagans, invented the arrangement shown in Fig. 6. The axles of the truck were acted upon by a vertical lever *a*, oscillated through the intermediary of a

longitudinal rod by lever *a'*, oscillated by the piston rod. The upper end of the lever *a* is connected to the top of an equalizer *b*, pivoted in the middle and having its lower extremity attached by a distance rod to the rear axle *c*, of the truck. The result of this arrangement is that if, on curves, the axles of the truck are displaced, the lower part of the lever *a* has a displacement in the same direction and to the same amount, so taking care of the convergence of the axles. The Hagens system was at first considered quite a success on the Prussian State Railroads on five-axle coupled locomotives weighing 72 tons in service, but it has since been entirely abandoned because the introduction of locomotives with five axles, parallel and coupled by ordinary side rods, has made it unnecessary.

The Johnstone system, which has been applied on several large duplex locomotives built in the United States for the Central Mexican Railroads, has some resemblance to the preceding type. Fig. 7 shows one-half of this locomotive, the other half being entirely similar. The piston rod acts on the middle of a lever *a*,

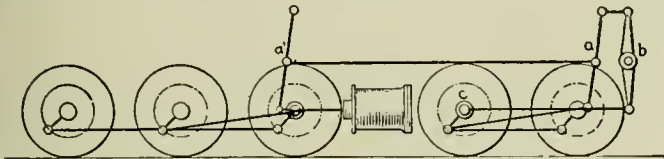

Fig. 6—Hagen's Five-Axle Locomotive

which is vertical when in its normal position. The main connecting rod is attached to the lower extremity of this lever while from the upper extremity a short coupling rod connects to the top of equalizer *b*. This equalizer oscillates about its middle and operates from its lower end a connecting rod to a crank pin set at 180 deg. from the working pin of the counter-crank. The lever *a*, to which the piston rod is attached, moves always parallel to itself, vertically on straight track and at a slight incline on curves.

The use of a free axle coupled by connecting rods with radial axles appears to date back to the Semmering Competition. Maffei there presented several designs in which the axles of locomotives and their tenders were coupled by inclined or triangular connecting rods. A similar design (Fig. 8), submitted at the same Competition by a Hannoverian engineer, Kirchweger, shows a locomotive carried on two trucks having two axles

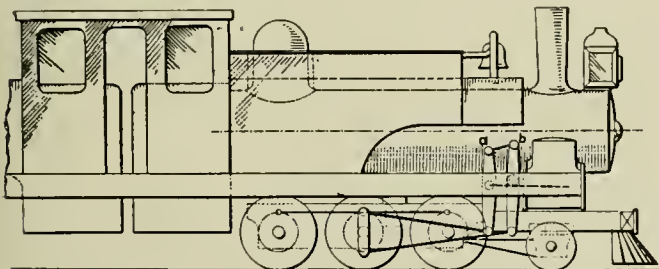

Fig. 7—Johnstone System of Equalizer Transmission

each, the coupling of the trucks being effected by an arrangement of this kind. It may be seen that there is a connection between the journal boxes of the wheel axles and of the free axle.

The Austrian engineer, Pius Fink, tried to retain in the Engerth machine its original property of total adhesive weight by substituting for the gear train an articulated device, using a free axle. These locomotives were in service for several years.

Rarchaert, after having abandoned the system of oscillating levers, designed an arrangement coming under the present category (Fig. 9). This was applied on a locomotive with two trucks having two axles each. The cylinders operated a free axle coupled with the carrying axles by a triangular central connecting rod. The pins of the cranks had spherical heads. The locomotive gave good results, but at the death of the in-

ventor experiments with it were discontinued. It is of interest to recall that the author of this ingenious system was a watchmaker.

The well-known designer, Krauss, of Munich, proposed in 1893, an arrangement permitting of the operation of the axles of a truck by steam cylinders carried on the main frame of the engine, as shown in Fig. 10. To accomplish this, the crank pins on the driving shaft carry pin blocks working in slots in the trussed connecting rods. The use of such connecting rods is subject to serious objections. Stress is exerted on the crank pin in a vertical direction only and, moreover, the pin blocks have on curves a periodic displacement in a direction transverse to the axis of the connecting rod. None of these systems appear to have been utilized practically.

Under the classification of external connecting rods, the lengths of which vary with the convergence of the axle, reference will be made first to the Klose system, which has been fairly widely applied. It may be seen from this figure that the crank pin of the working axle carries a kind of rocker lever to two points of which are connected the coupling rods of the other axles. The other two points are connected to the extreme axles by a system of connecting rods and triangles in such a

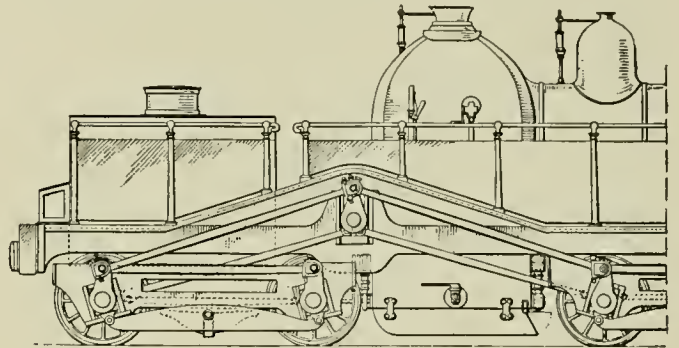

Fig. 8—Kirchweger Free-Axle Locomotive

manner that the convergence of the axles corresponds to the variation in length of the coupling rods. This system has been employed in locomotives having a gage of 5.77 ft. on the Bosnian-Herzegovinian Railroads and on large five-axle locomotives of the Wuerttemberg State Railroads.

In the Vogel system (Fig. 11), it has been proposed to couple the fixed axles of the locomotive with the axle of a pivoting truck placed under the tender. The crank pin of the wheel glides in a slot cut in the external connecting rod and the main rod connects with the spherical head of an equalizer connecting the two coupling rods. This system appeared in 1878.

CONCLUSION.

An examination of these devices gives the impression that all of them involve a serious inconvenience, and that all of them can operate in a satisfactory manner only when they are in vertical play, parallel to the longitudinal axis of the engine, *i. e.*, when the latter runs along straight sections of track. More than fifty years ago, J. J. Meyer, author of the first system of articulated locomotives which has given practically satisfactory results, wrote the following: "In the systems proposed for coupling in a rigid manner in whatsoever way it may be, the several axles belonging to two diverging trains, the addition of coupling mechanism introduces a greater complication than the addition of two extra steam cylinders, and the maintenance of these mechanisms, as well as keeping the drive wheels rigidly to the same diameter, will be of greater cost than that of the two extra cylinders and the two mechanisms, without taking into consideration the loss in efficiency."

DISCUSSION

E. A. Averill: It is possible in a two-cylinder locomotive to obtain a tractive effort around 100,000 lb. as far as the cylin-

ders are concerned. In view of the limitations of a satisfactory factor of adhesion and safe weight on each driving axle, such a tractive effort would necessitate the use of 12-coupled drivers, which means a driving wheel base of approximately 26 ft. 6 in. for drivers 60 in. in diameter. Such a rigid wheelbase would be impossible for ordinary use, with no arrangements allowing sidewise action of the driving wheel other than the setting in of the tires or the use of blind tires. We have reached a tractive effort of nearly 85,000 lb. and a wheelbase of 22 ft. It is not a very great step from that to 100,000 lb., a step that is desired and probably will be undertaken, but there is an important problem to solve in connection with this very long wheelbase.

W. F. Keisel, Jr. (Pennsylvania Railroad): Apparently few of the designs shown in Mr. Mallet's paper have reached the

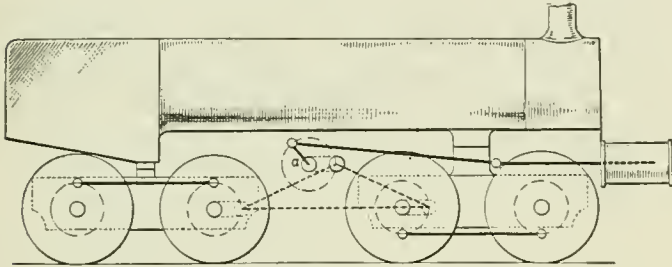

Fig. 9—Rarchaert's Free-Axle Design

experimental stage and none have come into general use. This is sufficient indication that their practicability is doubtful. The further fact that other solutions of the problem, less expensive and complicated, have been found would lead to the conclusion that such schemes will probably never be adopted, their only advantage being that all the axles can be driven from a single set of cylinders.

The weight and size of modern locomotives are so great that the cylinder diameters are now as large as road clearances will permit. If larger locomotives are built, the application of two or more sets of cylinders will probably be obligatory. If the number of sets of cylinders is increased the Mallet type is the logical type to use, as no change in the customary construction

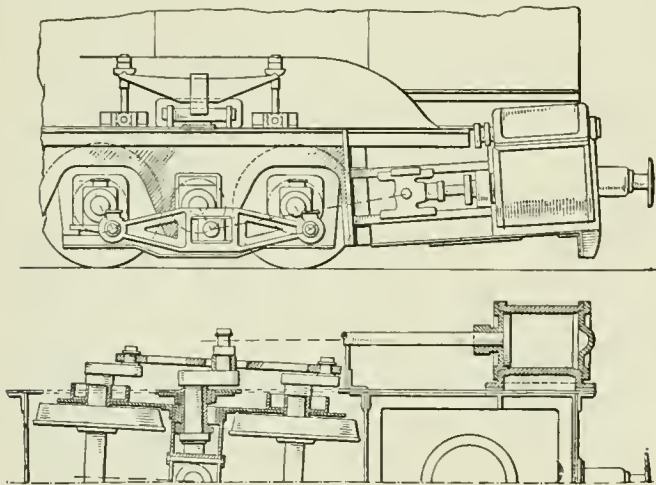

Fig. 10—Krauss' Slotted Rod Arrangement

of side rods, pins, etc., is necessary. In the Mallet type all necessary flexibility that may be required on account of track curvature can readily be obtained, making it unnecessary to consider further the flexible drive. Another reason why such types are not likely to come into practical use is that the loss in efficiency would be greater than the loss due to carrying 10 or 15 per cent of the weight of the locomotive on truck axles.

C. J. Mellin: Various forms of gearing were among the

first means sought to transmit motion from one set or group of axles to another. This has probably been the most successful principle applied for this purpose. The application of chains for the transmission of power from one axle to another was also tried at an early date, but probably owing to defective or weak chains, it was abandoned at the outset and reintroduced at a comparatively recent time on log engines. A number of such engines have been built and are reported giving satisfactory service, the chains permitting greater freedom of the axles than the coupling rods, on a rough road bed.

Theoretically the nearest correct method for self-alignment of individual axles on curves is that developed by Haywood (Fig. 3). The axles not only assume a radial position, but the entire wheelbase conforms to the curve, the middle axle being forced out against the outer rail. It does not appear, however, that it can be applied to any but light engines, due to the unfavorable carrying of the weight on the crank axles at the ball connections in the middle between the frames. It is also a question whether the wheels will run steady on a straight track, as it appears that they are liable to wobble from one rail to the other, being confined only by the single ball in the hollow axle.

G. R. Henderson: When a large number of axles are operated by one pair of cylinders, we have the following objectional features: Large and unwieldy cylinder proportions and parts; great loads on rods, crossheads, guides and main crank pins; heavy rods and reciprocating parts; increased difficulty in

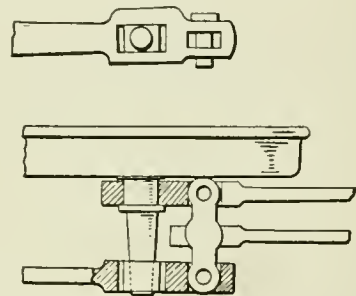

Fig. 11—Vogel System of Offset Rods

lubricating the bearings and rubbing surfaces; greater labor in making round house repairs and adjustments. When operating on the road the most objectionable feature is found in the loss of headway due to slipping of the drivers, practically stalling the train on heavy grades, whereas, in the Mallet type of locomotive, it is a well-known fact that the drivers of both high and low pressure units practically never slip at the same time. This is one of the most valuable features of the Mallet type locomotive and ordinarily is not given sufficient consideration in selecting locomotives for heavy drags.

W. E. Woodard (American Locomotive Company): From the standpoint of tracking, the problem of operating a long coupled wheelbase with a single pair of cylinders could undoubtedly best be solved by arranging certain of the wheels so that they could deflect radially. However, this involves mechanical difficulties which, so far, have appeared to be difficult to solve, at least for heavy locomotives. A practical solution would seem to be a compromise construction which permits of lateral motion of certain of the coupled wheels in a plane parallel with the other coupled axles. A comparatively simple side rod construction can be used which will readily take care of the side motion required. The Zara and other similar truck constructions, which have been used abroad, are based on this general principle. Floating coupled axles in which an abnormal amount of lateral play is allowed to accommodate the curving of the wheelbase, have also been used abroad and to a limited extent in this country. Floating axles with lateral play will certainly allow long wheelbase engines easily to pass sharp curves, but their use is open to the objection that they do not contribute any guiding effort on curves, or steadying action on tangent track, until the full lateral play is taken up. Moreover, because

such axles are free to move laterally, almost all the flange wear comes on those coupled wheels which have normal lateral play. The ruling of the Interstate Commerce Commission, lately made, covering allowable lateral play between driving wheel hubs and driving boxes, is also an objection to this construction.

It is evident that the design of lateral motion coupled axles which will best meet the conditions of the case should be capable of application to any or several pairs of the coupled wheels. Thus it may be desirable to equip the first and last coupled axle with a lateral motion device, or possibly even the first, last and middle pairs of wheels. There has recently been placed in service an arrangement of lateral motion coupled axle which meets these requirements. It provides sufficient flexibility to admit of a locomotive with a long driving wheelbase curving easily and at the same time affords a definite resistance against lateral motion. This design is in successful operation on a number of heavy 10-coupled locomotives on the New York, Ontario & Western and has also been used on a similar class of locomotives of unusual weight and power just going into service on the Erie Railroad. Briefly, the design consists of an arrangement which permits of about 2 in. total side play of the leading coupled wheels and boxes. This lateral motion is resisted and controlled by a constant side resistance which is obtained through the action of the load carried on the boxes. In this way, a positive gravity control is obtained against an initial side motion of the wheels and throughout the entire range of this motion up to its limit. The side rods connecting this pair of driving wheels with the second pair of wheels are arranged with ball knuckle-joint pins and a special design of spherical crank pin. The New York, Ontario & Western 2-10-2 type engines have 28-in. by 32-in. cylinders, 57-in. driving wheels, a rated tractive effort of 71,200 lb. and a driving wheelbase 20 ft. long. The Erie 2-10-2 type has 31-in. by 32-in. cylinders, 63-in. driving wheels, a rated tractive effort of 83,000 lb. and a driving wheelbase of 22 ft. 6 in. In both designs flanged tires are used on all the driving wheels. These engines pass readily around yard curves of 20 deg. without cramping or grinding.

The principle of applying a yielding resistance to control the motion of the driving axle having lateral play appears to be fully justified by the results of operation so far obtained. Observations of the engines in service show that there is no lateral motion of these wheels on tangent track and on ordinary line curves, even when the engine is working very hard at moderate speeds. The tire wear also appears to be about evenly divided between the first and the second driving wheels. These applications seem to justify the expectation that this construction can readily be extended to a 12-coupled locomotive having lateral motion driving axles front and back. With such a locomotive, a tractive effort of 100,000 lb. with a single pair of cylinders could be obtained within the limit of wheel loads which have been used on a number of existing locomotives. The construction is also applicable to Mallet locomotives, thus increasing the number of pairs of coupled wheels in each unit.

Geo. L. Fowler: I have made a few investigations relative to lateral wheel pressures on curves, and have gotten what were, to me, astonishing results. There is one thing that stands out very clearly and that is the fact that the leading truck has a very material effect upon the distribution of the lateral thrust. I found that in negotiating curves, the leading truck of a Consolidation locomotive has the greatest amount of pressure on the rail, then comes the second driver, followed by the first driver, the third driver and fourth driver, in the order named. Turning the engine around and running it backward, the rear wheel strikes a tremendous blow and the rest of the wheels travel around with very little pressure. The same thing was manifest in connection with Pennsylvania electric locomotives. The leading driver on the rear unit put most of the pressure on the rail. I have never investigated the Mallet type, but I believe the blow from the leading wheel of the second unit would be a pretty serious thing at high

speeds on sharp curves. As to switch engines and Consolidation locomotives running backward, I believe the speed should be limited to not more than 20 or 25 miles an hour.

The easiest riding locomotive is the old American type, followed by the Pacific type, if the weight is not considered. With the latter type the lateral pressure from the trailing wheel was invariably much higher than that from the rear driver. The pressure in the case of tenders was very light, but with a train negotiating a sharp curve at high speed, the effect of the locomotive is slight compared with that of the sleeping cars following. With a Pacific type locomotive pressures were recorded from 13,000 lb. to 14,000 lb. for a single wheel, followed by a sleeping car with 32,000 lb. to 36,000 lb.

In regard to the limitation of lateral motion in the driving boxes, I could find no difference in a large number of engines on curves, where the engine apparently bears over against the outer rail, but on tangent track side motion is an important factor. A dilapidated locomotive, with from 1½ in. to 1¾ in. side motion and just ready to go into the shop, slides over a tangent track with an ease that is surprising. With about ¾ in. lateral motion, heavy blows may be expected.

E. B. Katte (New York Central): Some experiences derived in the development of the earlier types of high-speed electric locomotives do not agree with Mr. Fowler's experience in regard to lateral motion. We found in the early type of electric locomotive, which only had a two-wheel guiding truck, that if there were considerable lateral motion, either in running into a curve, or in running off a curve, there was a tendency to throw over from one side to the other. The effect of the low center of gravity was accentuated by the lost motion, and we would gradually get such a cumulative shock at speeds of 80 or 85 miles an hour that we would break the track, which was relatively light. Taking the same locomotive with hardly any lost motion, we could run it at almost any speed without getting a knock against the rails.

W. E. Woodard: I do not see why it should not be possible to provide cylinders large enough to take care of 12-coupled drivers, although they will slightly exceed the sizes we have been using up to this time. The 12-coupled locomotive would probably take a 32-in. or 33-in. cylinder, well under the size of cylinders used on the Mallet. If any one had said anything a short time ago about building 85,000-lb. tractive effort units we would have thrown up our hands, but we have done that. I see no obstacles to prevent going up to a simple locomotive with 100,000-lb. tractive effort.

On the New York, Ontario & Western engines there are no indications whatever of the driver deflecting under the most severe working of the engines, even at seventy-five revolutions per minute, when there was the greatest tendency to nose. In fact, an indicator on the lateral motion device showed no deflection on any curve or tangent track except when going over a cross-over, or a very sharp turn-out in the yard.

C. D. Young: I can see no particular difficulty in reaching 100,000-lb. tractive efforts, but I do not believe that the use of two cylinders is the way to do it. It should be done either with two pairs of simple cylinders, or with three simple cylinders. In that way the long overhang of the main pin, which would result from the wide spread, would be overcome, as well as the trouble with cylinder clearances. If the cylinders were made large enough to limit the full gear position to a reasonable cut-off, I believe a boiler could be made which would develop the possibilities of 100,000-lb. tractive effort. I see no use, however, for such a locomotive if the boiler will not supply the steam. There should be three or four cylinders large enough to permit the valve gear to be so arranged that the maximum cut-off would not be over 65 or 70 per cent, thus making it possible to develop full tractive effort at a reasonable water rate. The water rate of the two-cylinder engine, working full gear at seven or eight miles an hour, is about 31 lb. per hp. hr. with 225 deg. of superheat. If the cut-off is reduced 50 per cent the water rate drops to 18.5 lb.

EXAMPLES OF RECENT SWITCHING LOCOMOTIVES OF THE 0-6-0 AND 0-8-0 TYPES

Type	0-6-0	0-6-0	0-6-0	0-6-0	0-6-0	0-6-0	0-6-0	0-6-0	0-6-0	0-6-0	0-8-0	0-8-0	0-8-0	0-8-0						
Name of road	S.P.&S.	K.C.S.	C.R.I.&P.	L.C.	N.Y.C.	T.R.R.A. of St.L.	Sou.	Erie	Penn. Lines	N.Y.C.	N.E. Gas & Coke Co.	N.J. Zinc Co.	L. & J. Bridge Co.	0-6-0	0-8-0	Buffalo Creek	0-8-0	Wash. Sou.	N.Y.C.	
Builder	.....	.....	.....	.....	.....	.....	.....	.....	.....	.....	.....	.....	.....	.....	.....	.....	.....	.....	.....	.....
When built	.....	.....	.....	.....	.....	.....	.....	.....	.....	.....	.....	.....	.....	.....	.....	.....	.....	.....	.....	.....
Tractive effort, lb.	31,200	34,300	32,950	34,400	33,140	45,500	32,015	29,932	36,092	33,130	38,300	37,800	37,000	43,500	45,200	45,200	49,000	49,600	49,500	49,500
Weight, total, lb.	152,000	158,000	162,000	164,000	172,000	198,000	143,200	153,100	168,100	162,300	152,400	154,450	165,000	196,000	206,000	206,000	216,000	229,000	240,000	240,000
Weight on drivers, lb.	132,000	158,000	162,000	169,000	172,000	198,000	143,200	153,100	168,100	162,300	152,400	154,450	165,000	196,000	206,000	206,000	216,000	229,000	240,000	240,000
Maximum weight on one pair of drivers, b.	51,800	51,600	53,800	57,500	60,200	67,000	53,200	51,600	57,400	57,000	51,650	54,400	56,500	51,600	52,000	52,000	55,500	59,300	60,400	60,400
Weight of tender, lb.	95,500	112,500	106,200	101,400	101,900	135,000	93,300	95,600	132,000	102,400	88,000	98,500	101,400	103,000	109,600	109,600	146,000	183,400	148,300	148,300
Wheel base, driving, ft. & in.	11-0	11-6	11-0	11-8	11-6	12-0	11-0	11-0	11-6	11-6	13-6	11-0	11-6	15-0	14-6	14-6	15-6	15-6	16-0	16-0
Wheel base, total engine, ft. & in.	11-0	11-6	11-0	11-8	11-6	12-0	11-0	11-0	11-6	11-6	13-6	11-0	11-6	15-0	14-6	14-6	15-6	15-6	16-0	16-0
Wheel base, total engine and tender, ft. & in.	41-10	44-2	42-6	44-2	42-7	47-1 1/4	43-4 3/4	42-6 1/4	48-6 3/4	42-0 1/4	43-1 1/2	43-10	42-7	41-11 1/4	47-0 1/2	47-0 1/2	50-7 1/4	57-3	53-8 1/2	53-8 1/2
Diameter of drivers, in.	51	50	52	51	57	51	51	50	56	57	51	51	51	53	51	51	57	51	51	58
Cylinders, number	2	2	2	2	2	2	2	2	2	2	2	2	2	2	2	2	2	2	2	2
Cylinders, diameter	20	20	20	21	21	22 1/2	20	20	22	21	21	22	21	22	22	22	24	24	25	25
Cylinders, stroke	26	28	28	26	26	30	26	26	24	28	26	26	28	28	28	28	30	30	30	30
Valve gear, type	.....	Wals.	Baker	Wals.	Wals.	Wals.	Steph.	Steph.	Steph.	Wals.	Steph.	Steph.	Wals.	Steph.	Wals.	Baker	Baker	Baker	Wals.	Wals.
Steam pressure, lb.	180	180	180	180	180	180	185	180	205	180	200	180	180	200	200	200	190	185	180	180
Boiler, type	.....	E.W.T.	E.W.T.	E.W.T.	.....	.....	.....	.....	.....	.....	.....	.....	.....	.....	.....	.....	.....	.....	.....	.....
Boiler, outside diameter, front end, in.	72 1/4	62	63 1/4	66 3/4	67 1/4	80	63	68 1/4	68 3/4	67 3/4	72	74	67 3/4	80	74 1/2	74 1/2	74 1/4	80	72 3/4	72 3/4
Tubes, number and diameter, in inches	192-2	152-2	151-2	163-2	165-2	230-2	300-2	302-2	323-2	165-2	325-2	335-2	163-2	440-2	221-2	221-2	214-2	214-2	184-2 1/4	214-2
Flues, number and diameter, in inches	25-5 1/2	22-5 1/2	21-5 1/2	21-5 1/2	22-5 1/2	28-5 1/2	28-5 1/2	.....	.....	.....	.....	.....	.....	.....	.....	.....	.....	.....	.....	.....
Length of tubes and flues, ft. & in.	11-0	12-6	10-0	14-9	10-0	14-6	15-1 1/2	11-6	13-11 1/4	16-0	13-6	10-6	16-0	15-0	15-0	15-0 1/2	14-9 1/2	14-9 1/2	30-5 1/2	30-5 1/2
Heating surface, tubes and flues, sq. ft.	1400	1381	1739	1695	1879	2317	2376	1805	2312	1896	2283	1826	1862	3436	2394	2394	2310	2314	179	2548
Heating surface, firebox, sq. ft.	144	145	114	139	129	175	110.5	152	152	125	137	109	126	170	167	167	191	191	179	179
Heating surface, arch tubes, sq. ft.	.....	.....	13	15	13	16	.....	20	.....	15	.....	.....	13	.....	.....	.....	.....	.....	.....	.....
Heating surface, total, sq. ft.	1634	1526	1866	1849	2021	2508	2486.5	1977	2494	2036	2120	1995	2001	3606	2583	2583	2516	2527	2752	2752
Heating surface, superheater, sq. ft.	280	310	380	360	350	460	.....	.....	.....	396	.....	.....	403	.....	.....	.....	547	720	580	580
Heating surface, equivalent, sq. ft.	2054	1901	2436	2389	2591	3198	2486.5	1977	2494	2630	2420	1995	2606	3606	3668	3668	3337	3607	3622	3622
Grate area, sq. ft.	28.0	42.0	31.7	43.0	32.6	41.1	29	52.3	41.25	32.6	40	57	32.7	48.0	47.5	50.2	55.0	55.0	53.3	53.3
Firebox, length, in.	96	84	68	86	72	84	66	114 1/4	90	72 1/2	96 1/2	113 1/4	72 1/2	96	96	120	120	120	102	102
Firebox, width, in.	42	72	67 1/4	72	65 1/4	70 1/4	66	66	66	65 1/4	60 3/4	72 1/2	65 1/4	72	71 1/4	60 1/4	60 1/4	66	75 1/4	75 1/4
Kind of fuel	.....	Oil	Bit. Coal	Bit. Coal	Bit. Coal	Bit. Coal	Bit. Coal	Bit. Coal	Bit. Coal	Bit. Coal	Coke	Ant. Coal	Bit. Coal	Bit. Coal	Bit. Coal	Bit. Coal	Bit. Coal	Bit. Coal	Bit. Coal	Bit. Coal
Tender, water capacity, gal.	4000	5600	5000	5000	5100	7000	4500	4500	5500	5100	4000	4500	5100	5000	5500	7400	10,000	10,000	7500	7500
Tender, fuel capacity, tons or gallons	1900	8	7 1/2	6 1/2	7 1/2	12	7	7	6	7 1/2	8	8	7 1/2	8	8	14	15	15	14	14
Weight on drivers ÷ tractive effort	4.87	4.61	4.92	4.91	5.19	4.35	4.47	5.11	4.65	4.89	4	4.09	4.46	4.51	4.56	4.41	4.62	4.62	4.85	4.85
Total weight ÷ tractive effort	4.87	4.61	4.92	4.91	5.19	4.35	4.47	5.11	4.65	4.89	4	4.09	4.46	4.51	4.56	4.41	4.62	4.62	4.85	4.85
Tractive effort X diam. drivers ÷ equivalent heating surface*	774.6	861.3	703.3	734.3	729.0	725.6	656.6	757.5	810.4	718.0	805	966.3	794.3	639.3	684.5	837.1	701.3	701.3	792.6	792.6
Equivalent heating surface ÷ grate area	73.35	47.4	76.84	55.55	79.47	77.81	85.74	37.7	60.46	80.67	60.5	35.0	79.66	75.12	70.89	66.45	65.58	65.58	67.95	67.95
Firebox heating surface ÷ equivalent heating surface*, per cent.	7.01	7.28	4.68	5.82	4.98	5.47	4.44	7.68	6.09	4.74	5.66	8.47	4.83	4.71	4.96	5.30	5.30	5.30	4.94	4.94
Weight on drivers ÷ equiv. heat. surface*	74.0	79.35	66.5	70.74	66.38	61.91	57.59	77.44	67.40	61.71	62.97	77.41	63.34	54.35	61.17	64.73	63.48	63.48	66.26	66.26
Total weight ÷ equiv. heat. surface*	74.0	79.35	66.5	70.74	66.38	61.91	57.59	77.44	67.40	61.71	62.97	77.41	63.34	54.35	61.17	64.73	63.48	63.48	66.26	66.26
Volume both cylinders, cu. ft.	9.45	10.18	10.18	10.42	11.22	13.8	9.45	9.45	10.56	11.22	10.42	11.44	11.22	12.31	12.31	15.71	14.66	14.66	17.01	17.01
Equip. heating surface* ÷ vol. cylinders	217.3	195.57	239.29	229.27	230.92	231.73	263.12	209.20	236.17	234.4	232.24	174.38	232.21	292.93	273.55	212.38	246.04	246.04	212.55	212.55
Grate area ÷ vol. cylinders	2.96	4.13	3.11	4.13	2.91	2.98	3.06	5.53	3.90	2.90	3.84	4.98	2.91	3.90	3.86	3.20	3.75	3.75	3.13	3.13

\*Equivalent heating surface = total evaporating heating surface + 1.5 times superheater heating surface.

# CAR DEPARTMENT

## AUXILIARY CAR FOR WRECKING CRANE

The engraving shows a well-arranged auxiliary car which has been developed on the Canadian Northern and made standard for use with wrecking cranes on that road. One end of the car is enclosed for a length of 14 ft. 3 in. This compartment is fitted with two bunks, one upper and one lower, a stove, a drop table, a clothes locker and a tool and supply locker. Along the sides of the open portion of the car are weatherproof bins about 2 ft. 6 in. wide inside, divided into sections in which are stored cables and chains of various sizes together with a supply of waste. These bins are 3 ft. high and between them is a space

tributed between the draft gear and end sill. The point of contact between the horn of the coupler and striking plate is assumed to be 2 in. above the top of the coupler shank. For a shank 5 in. deep, the distance from the center line of draft gear to the assumed point of contact of coupler horn is  $4\frac{1}{2}$  in. This is the first time, to my knowledge, that any mechanical body has ever conceded that the center line of end force is above the center line of the coupler. This is as it should be, as there is no draft gear of sufficient capacity to entirely absorb this end force. I do not think that the assumed 250,000 lb. is sufficient. The assumed end force should be not less than 400,000 lb. static, basing my opinion on what I see in the field, and the tests made by Prof.

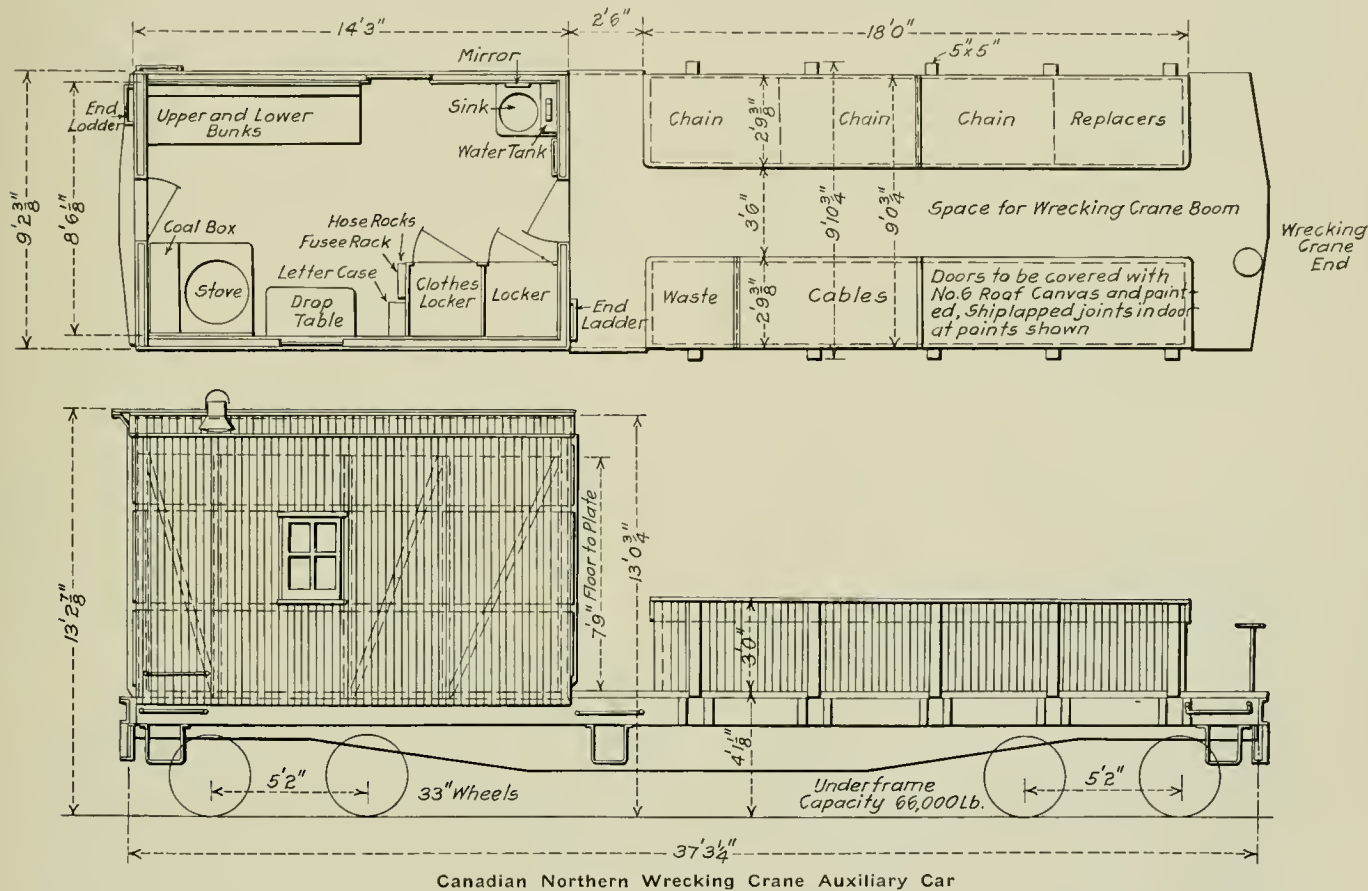

Canadian Northern Wrecking Crane Auxiliary Car

3 ft. 6 in. wide within which hang the crane hooks when the wrecking train is made up. The train consists of the crane, the auxiliary car, a tool car, a flat car for trucks, blocking, etc., and a boarding car for the crew, in the order named from the locotive. The auxiliary car was developed by A. L. Graburn, assistant superintendent rolling stock of the Canadian Northern.

## THE CAUSE OF SHOCKS IN LONG FREIGHT TRAINS\*

The Master Car Builders' Association Committee on car construction has stated that the intensity of end force on freight cars is assumed to be equivalent to 250,000 lb. static, which may be concentrated on the center line of the draft gear, or dis-

tributed between the draft gear and end sill. The statement was made by D. F. Crawford, general superintendent motive power, Pennsylvania Lines West, at Atlantic City last June, referring to the tests made in 1903 and 1904 with a dynamometer car: "At that time it was found that the shock recorded by the dynamometer car was about 100,000 lb. per mile per hour, up to six miles per hour, when the entire capacity of the dynamometer car, which was some 615,000 lb. was absorbed." Using this as a basis, let us see what we find in everyday service. First, take a level yard, where the switching is usually done by a switching crew of three men. Do you find any of them setting brakes to diminish impact with other cars? Do they switch cars at less than four miles per hour? The hump yard conditions are somewhat improved because there are usually enough men to ride all cuts of cars that go over the hump. But the worst of all are our road conditions, due to the slack in our trains.

The heavy shocks in trains are sometimes attributed to the recoil of the draft gear, but this is not the case. They are

\* From a paper by H. C. Priebe, Chicago Steel Car Company, read before the Car Foremen's Association of Chicago, December 13, 1915.

caused by the slack in the train. Many shocks occur every day and it is only when actual damage is done or passenger trains delayed that the trainmen will even report them.

The M. C. B. coupler committee has been working on a new standard coupler for some time. The only objection I have to this coupler is the size of the slot. In the present coupler we have a 5½ in. by 1¼ in. slot. In the new coupler we should have an opening for at least a 7 in. by 1¾ in. key. The bearing area in both the coupler and key is insufficient and is one of the many causes of so much slack in our trains.

Attention should also be directed to the draft gear, which is the greatest slack producer we have. The M. C. B. committee sent out a circular of inquiry early in 1915, with a number of questions for the purpose of finding out general practices. One of the questions was: "What is your recommendation for coupler travel in connection with high capacity draft gears?" Of the replies, 36 per cent. expressed a preference for more coupler travel than the present standard of 2¾ in. between coupler horn and striking plate, some of them as high as 5 in. It is strange that so many people overlook the fact that in train service there are always two draft gears between two cars, and every time the draft gear travel is increased one inch, the movement between two cars is increased four inches, and the slack two inches.

To illustrate, many modern friction draft gears have a travel of 3¼ in. This allows the coupler to move in 3¼ in. and out 3¼ in. from the normal position, allowing each coupler to move 6½ in. As there are two couplers between two cars, we have 13 in. of actual movement without considering clearance between knuckles, which will average another inch, making a total of 14 in. between each two cars in a solid steel train. Thus in a train of 100 cars, we have 116 ft. 8 in. of movement between cars, of which there is 62 ft. 6 in. of slack and 54 ft. 2 in. of resistance when new. After a year of actual service the gears will have lost another inch of resistance due to the wearing down of friction surfaces; we then have but 37 ft. 2 in. of resistance and 79 ft. 2 in. of slack, and so on. The result is the growing cost of freight car repairs. We are trying to absorb momentum with the draft gear, that should be controlled by the brakes. My experience has been that whenever an engine fails to start a train with resilience enough to equal one revolution of the drivers, it will be unable to take the train to destination. Then, why should there be 60 ft. or more of slack, in addition to the resilience?

Drawbar resistance should be increased and the travel should be reduced to produce results without depending on the engineer's judgment as to how much slack he can take with safety. The facts are that excessive drawbar travel produces excessive slack; and while the draft gear may act as a shock absorber, slack is certainly a shock producer. Trainmen can be instructed on the book of rules, bulletins may be posted, additional traveling engineers employed, but slack cannot be reduced by such methods. Emergency applications of air brakes are bound to take place; therefore the slack must be reduced to avoid collision shocks in road service.

If we must have friction to retard momentum let us have it on the brake shoes which can be properly adjusted and removed when worn out without going to the repair track, and insist that the brakes be used for this purpose, instead of the draft gear.

The best results in railroad train service were obtained when the resistance in the end of the cars exceeded the carrying capacity of the cars. Today the capacity of the cars exceeds the capacity of the draft gear. Go out in any yard when tonnage trains are pulling out and you will find 90 per cent of the draft gears stretched out absolutely dead by a locomotive with a tractive effort of less than 70,000 lb. I find that most of the friction draft gears are creepers, and will become dead under sudden jerks, thrusts, or constant load and remain so until the load is entirely removed, not having return power enough to come back under the strain of an ordinary engine. I also find this to be true in placing friction springs in car trucks; the capacity of the springs exceeding by far the capacity of the standard coil truck

springs, yet when forced down going over rough track they remain dead, absolutely worthless until the load is removed.

The greatest argument against the spring gears is a supposed recoil, but recoil we must have or we have no draft gear. If the recoil were as great as some people say it is, some of our trains would be aeroplanes, as no one hesitates to place sufficient springs in the trucks of cars to properly carry the load.

**WHEEL CLAMP AND JACK BLOCK**

A combination wheel clamp and jack block for use with journal jacks when changing brasses is shown herewith. This device was developed by H. J. White, supervisor of car work, Canadian Northern, Eastern Lines, and is extensively used on that system.

The jack block is a 2-in. by 9-in. white oak plank 3 ft. 9 in. long, to the center of which is attached an upright piece of spring steel 4-in. wide by ½-in. thick. This extends to a vertical

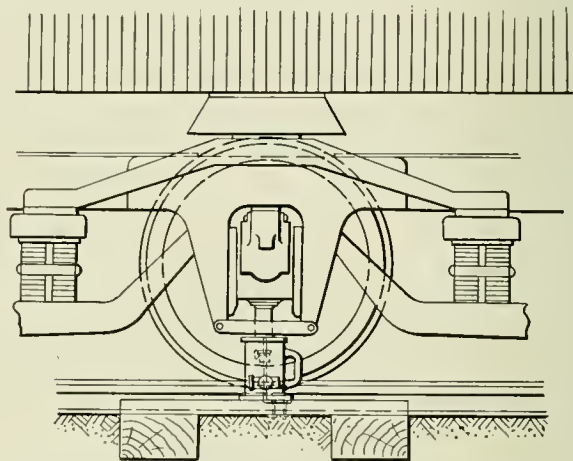

Method of Using Combined Jack Block and Wheel Clamp

height of 9¼ in. above the block and is provided with a number of 7/16-in. holes spaced ¾ in. apart on its vertical center line. A band sliding over the upright piece is provided at one end with a 1½-in. projection 1 in. in diameter.

One of the drawings indicates the method of using the jack block. It is placed under the journal box, the ends spanning

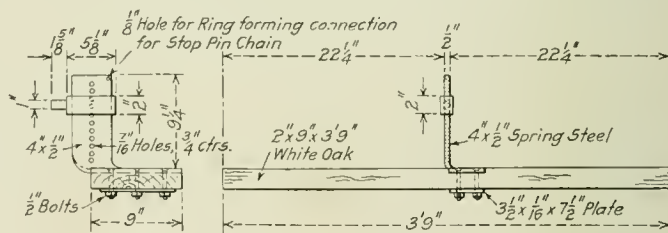

Journal Jack Block with Wheel Clamp

two adjacent ties. The projection on the sliding band is then dropped down against the inside rim of the wheel tread and held in that position by means of a pin placed through one of the 7/16-in. holes in the upright. The wheel is thus clamped against the rail and prevented from lifting as the journal box is raised.

**BRITISH LOCOMOTIVE EXPORTS.**—There was a slight improvement in British locomotive exports in September, the value of the shipments for the month having been about \$1,454,500, as compared with \$1,439,590 in September, 1914, and \$1,395,525 in September, 1913. The improvement was due to an increase in the value of the deliveries to the Argentine Republic during the month to \$118,720, as compared with \$34,855 and \$274,775. South Africa imported locomotives in September to the value of \$189,330, as compared with \$64,105 and \$133,185, but there was a great falling off in the deliveries to India and Australia.



# STEEL END BOX CARS FOR THE SANTA FE

## Box Cars of 40 Tons Capacity With Interesting Examples of Steel End and Side Door Construction

The Atchison, Topeka & Santa Fe has recently received from the Haskell & Barker Car Company, 700 36-ft. box cars of 80,000 lb. capacity, which include a number of interesting details of construction. These cars have steel ends and the truss rod type of

the ends being of especially substantial construction. The underframe is made up of 5 in. by 9 in. wooden longitudinal sills located 9 in., 2 ft. 1 $\frac{3}{4}$  in. and 4 ft. 4  $\frac{15}{16}$  in. each side of the center line of the car. The two center sills are reinforced with 8 in. ship

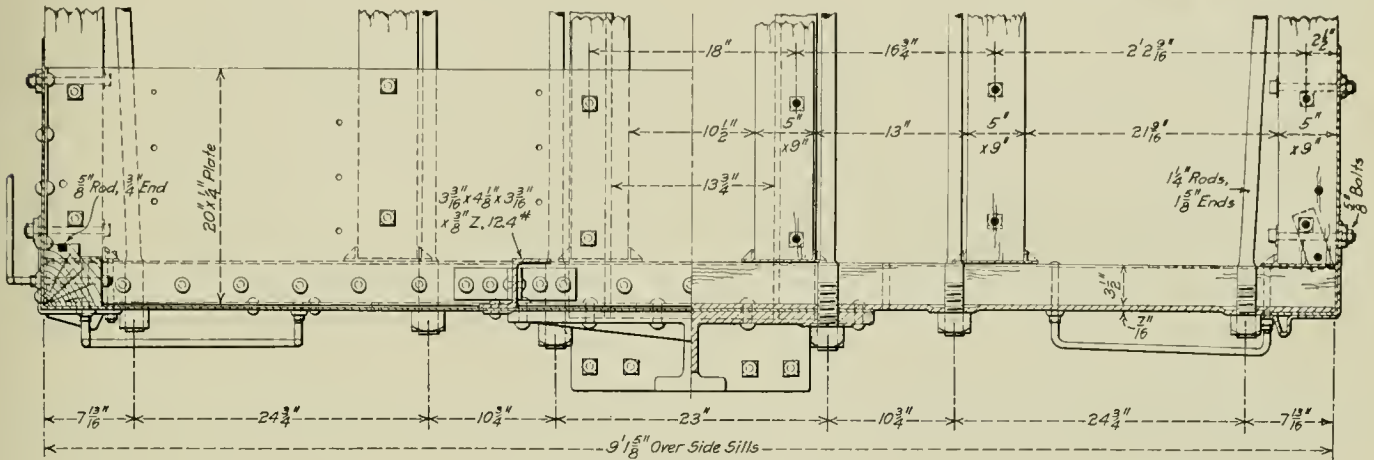

End Sill for Santa Fe Box Cars

underframe, and weigh 43,300 lb. The following is a list of the general dimensions:

Length over end sills.....	37 ft.
Length inside.....	36 ft.
Width over side sills.....	9 ft. 1 $\frac{5}{8}$ in.
Width over siding.....	9 ft. 3 $\frac{1}{4}$ in.
Width inside.....	8 ft. 6 in.

channels located directly underneath them, which form the draft members of the underframe. The bolt holes in the side sills are located to give the car body a camber of 1 in., which must be maintained with no tension on the truss rods. The truss rods are 1 $\frac{1}{4}$  in. in diameter and are located 6 in., 2 ft. 6 $\frac{1}{8}$  in., and



Atchison, Topeka & Santa Fe 40-Ton Steel End Box Car

Height inside, clear space.....	7 ft. 11 $\frac{1}{8}$ in.
Height from top of rail to top of running board.....	13 ft. 3 $\frac{1}{8}$ in.
Wheel base of car.....	32 ft. 1 $\frac{1}{4}$ in.
Wheel base of truck.....	5 ft. 4 in.

3 ft. 6 $\frac{1}{4}$  in. each side of the center line of the car. They pass over chairs on the body bolster and are anchored in the end sills. Cross beams consisting of 8-in., 18-lb. channels are located 4 ft. 3 in. each side of the transverse center line of the car. They

These cars were built for grain and heavy merchandise service,

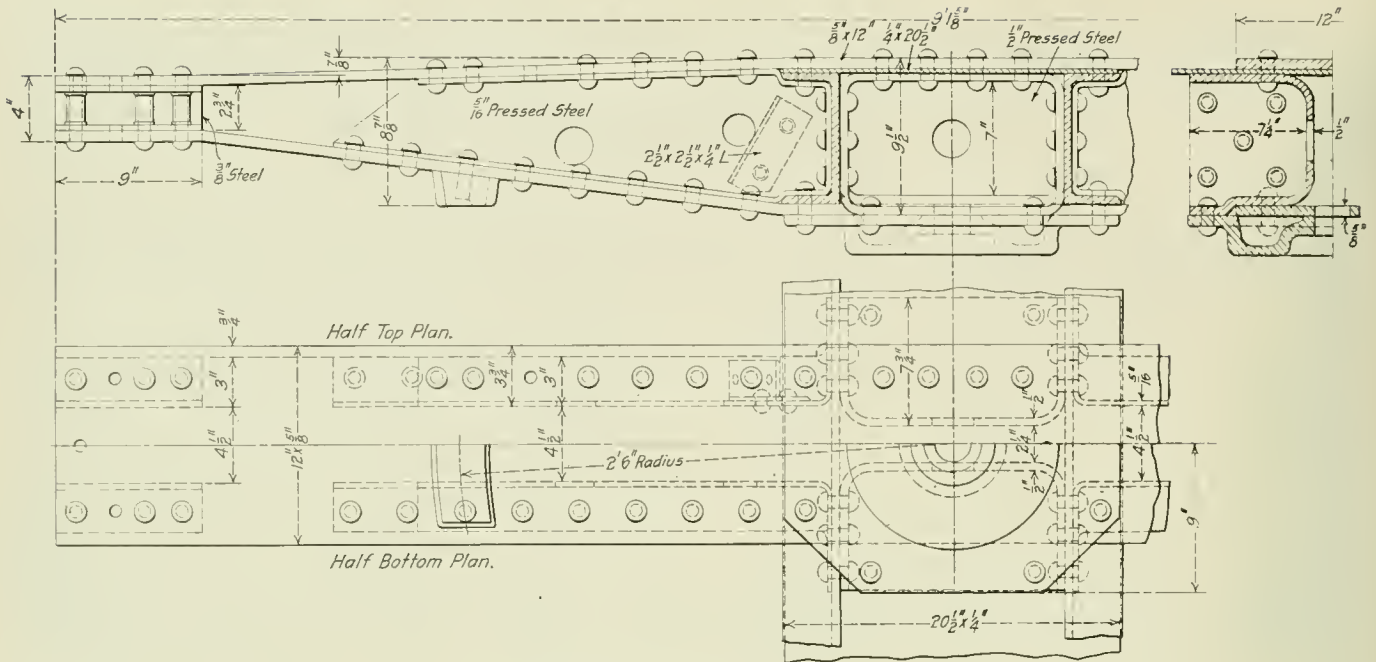

Body Bolster for Santa Fe Box Cars

are cut to fit against and between the draft sill channels and are riveted to gusset plates. They are bolted to the side and intermediate sills and support the queen posts for the truss rods. The body bolsters are located 5 ft. 2 9/16 in. back of the end

to the cover plates and center draft sills with 3/4-in. rivets. The body center plates are drop forgings and the side bearings are located 2 ft. 6 in. each side of the center line, the Standard Car Truck Company's roller truck side bearings being used. The

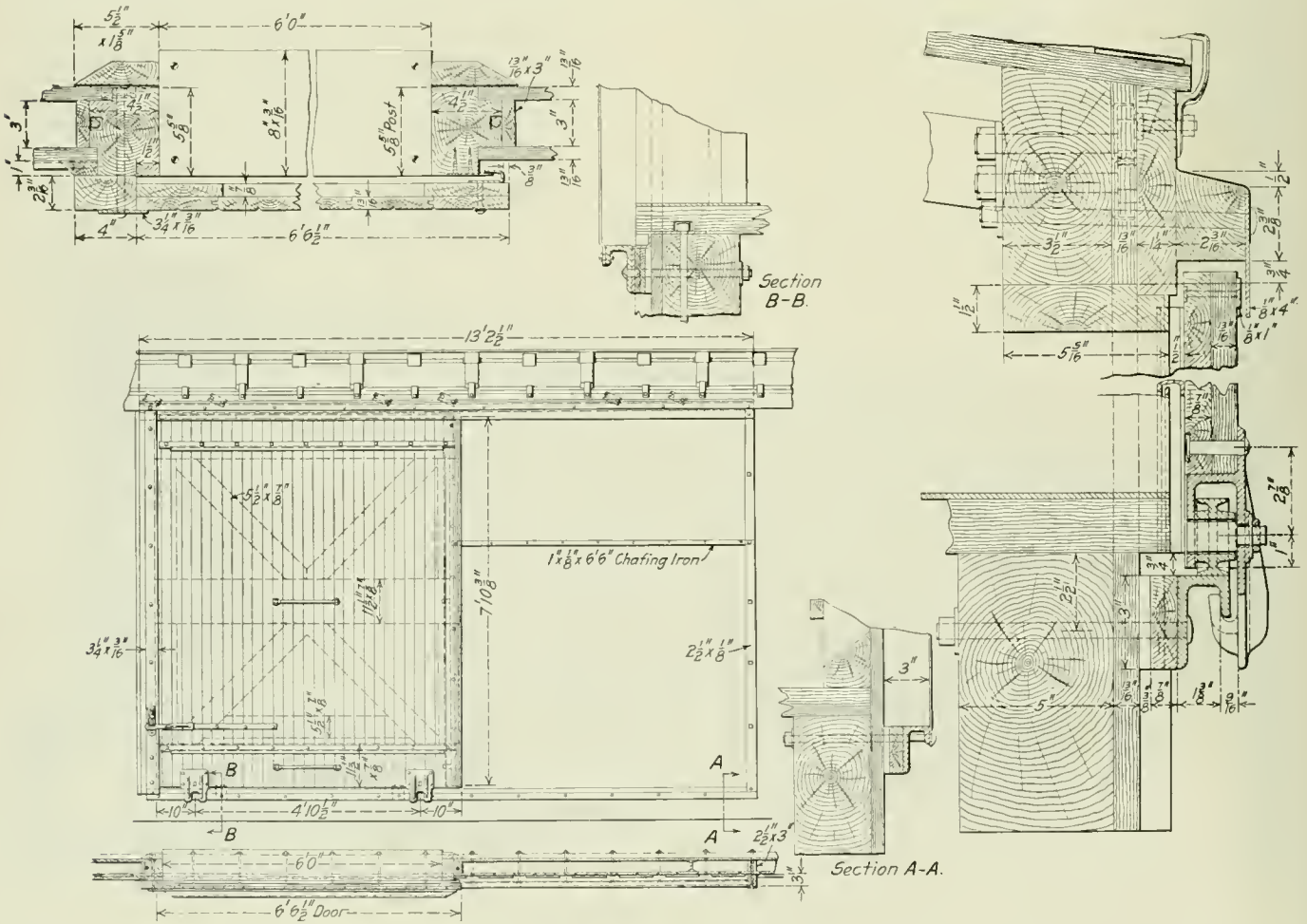

Santa Fe Box Car—Side Door Construction

sills. They are made up of 5/8-in. by 12-in. top and bottom cover plates with two 1/2-in. pressed steel center fillers, four 5/16-in. pressed steel intermediate fillers and four 3/8-in. end fillers riveted

end sills are 9-in., 286-lb. ship channels with 3 1/2-in. by 8-in. oak fillers. The channels are pressed to form a bearing for the truss rod nuts.

A unique feature in the design of these cars is the substantial end construction. It consists of two 4 1/8-in., 12.5-lb.

is 33 3/8 in. wide. It is offset at the sides to lap over the end sheets and is riveted to the end posts with the end sheets by

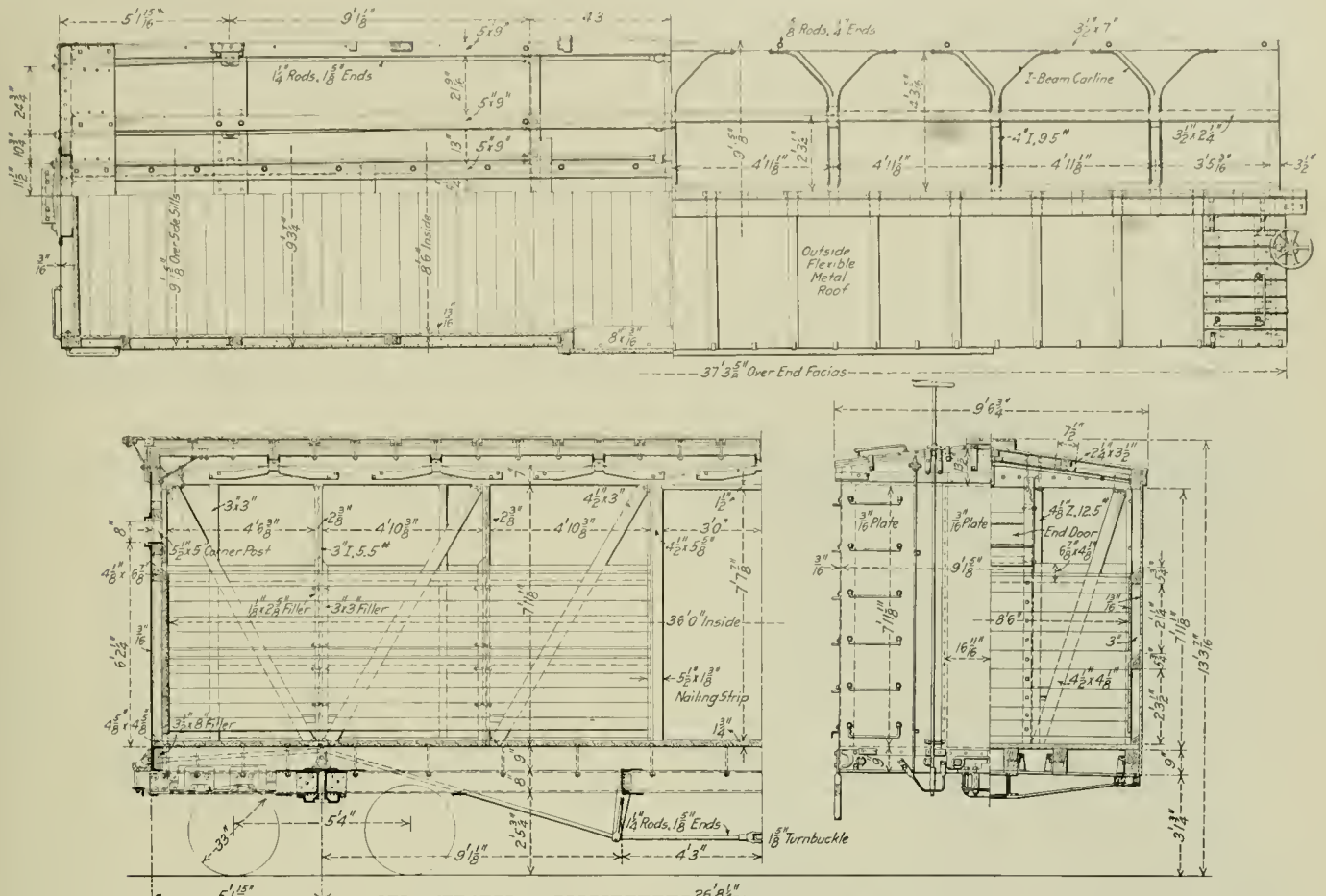

Elevation, Plan and Section, Santa Fe 36-ft. Box Cars

Z-bar end posts, 3/16-in. outside steel sheathing and a 1 3/4-in. wood lining inside. The outside steel sheathing is applied verti-

ally in three sections, the two outside plates extending around on the sides of the car for a distance of 23 in. The middle sheet

both at the ends and sides by 1/2-in. carriage bolts. The ladder irons are fastened to the car by these bolts at one end and are riveted directly to the steel sheets at the other end. The side sheathing is gained out to receive the end of the side sheets and they are both attached to a cripple post by 3/8-in. carriage bolts. At the bottom the steel plates are riveted to the end sill and bolted to the side sills and at the top are fastened to the end and side plates by 1/2-in. carriage bolts.

The side framing consists of eight 3-in., 5.5-lb. I-beams for side posts and twelve 4 1/2-in. by 3-in. wooden diagonals. The I-beams are provided with 1 1/8-in. by 2 3/8-in. wood fillers on one

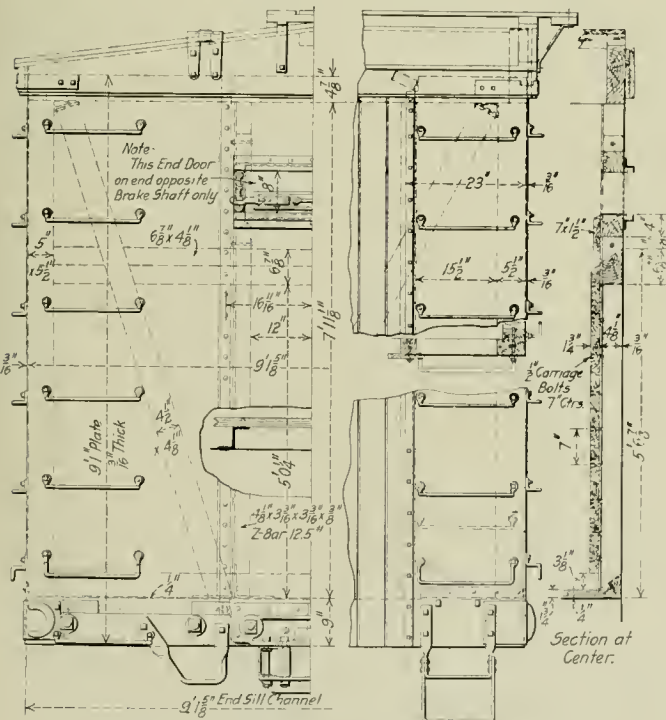

Steel End Construction, Santa Fe Box Cars

side and 3-in. by 3-in. fillers on the other to which is nailed the inside sheathing. The inside sheathing extends only 5 ft. 2 in. above the floor. It is 13/16 in. thick at the sides and 1 3/4 in. thick at the ends. As will be noted in the section through the framing, an opening is provided just above the lower belt rail and at the floor. This precludes the possibility of grain lodging between the lining and the outside sheathing. There are two

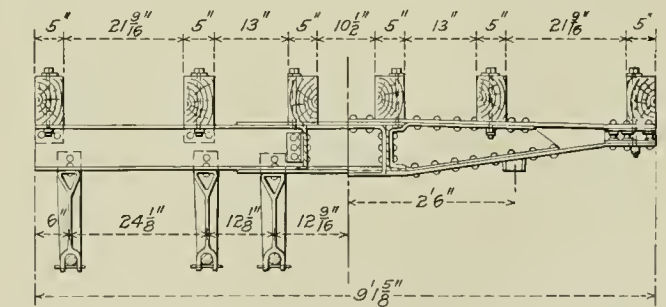

Half-Sections Through the Underframe

side and 3-in. by 3-in. fillers on the other to which is nailed the inside sheathing. The inside sheathing extends only 5 ft. 2 in. above the floor. It is 13/16 in. thick at the sides and 1 3/4 in. thick at the ends. As will be noted in the section through the framing, an opening is provided just above the lower belt rail and at the floor. This precludes the possibility of grain lodging between the lining and the outside sheathing. There are two

belt rails on the side of the car and one at the end. They are beveled on the upper face, as is the grain strip at the bottom, to prevent the grain from lodging on them. Seven 4-in., 9.5-lb. I-beams are used for the carlines. These are bent at the middle and split at the ends, the legs thus formed being spread out and bolted to the side plate as indicated in the plan view of the car. The ridge pole and purlins are bolted directly to the carlines.

The side doors are of particular interest. They operate on bottom rollers, the track being an inverted unsymmetrical U-section the long flange of which is bolted to the side sill with ½-in. carriage bolts. The roller housings have two legs which

## SOME LESSONS FROM EXPERIENCE WITH STEEL FREIGHT CARS

BY MILLARD F. COX

Assistant Superintendent, Machinery, Louisville & Nashville,  
Louisville, Ky.

### FIRST PRIZE ARTICLE\*

Since the advent of the all-steel freight car about 15 years ago, it has grown steadily in favor. It has come to stay. Beginning with the all-metal bolster, the use of steel has extended to nearly all parts of the car, including end and center sills, underframe and superstructure. Complete all-steel freight cars are now made in the following types: hoppers, gondolas, flats, box and house, and cabooses. This does not mean that there is no wood used in connection with their manufacture. In some instances, such as the house car, it is necessary and essential to have a wooden lining to protect the lading against the sweating of the steel and for general insulation purposes.

All-steel freight cars are so new that the best information as to their life is subject to modification. Like the modern steel building, it remains for time to get in its work before definite data of practical value can be obtained. There are some things, however, that we are reasonably sure of. All-steel freight cars will stand more hard service and general abuse than the best wooden car ever designed. They may be damaged in a variety of ways, just as other cars are, but seldom beyond recovery.

Steel cars should be painted occasionally, and they require some attention and repairs. All of this combined is considerably less than for the wooden cars, while the cost of maintenance is decreased correspondingly. Experience with all-steel equipment is convincing that the maintenance bugbear is not nearly so formidable as was anticipated.

The high type of hopper gondola car is costly to repair. The entire car must be dismantled in some cases, in order to straighten it properly. The cost for this is considerably more than for the composite car of the same capacity. By composite I mean the steel underframe and wooden superstructure. The steel car is seldom demolished beyond the repair point and while it requires more time and money to put it back into commission, it remains in service longer and takes extraordinary abuse without being destroyed. The design is more substantial and the material is of more lasting quality; therefore, we have a better car. For this we have paid more in the initial cost and have increased the weight somewhat, but have also added greatly to the life of the equipment. The all-steel car is the only kind that can be handled by the unloading machines in use at the Great Lakes and other points.

The deadliest enemy of the steel car is corrosion. We have watched this closely, and our observation shows a wasting of some of the members at various places on coal, refrigerator and ore cars, from 30 per cent to 60 per cent from the original dimensions. In some cases, for short distances, their strength is not only impaired, but almost destroyed. The cars on which we noticed as much as 60 per cent loss have been in service about 14 years. The side and center sills require reinforcing. We find it is cheaper to reinforce in some cases than to cut out the old member. Our engineers may do well to take this into consideration in future calculations in connection with load and buffing shocks.

If it were practicable to paint steel cars as we do bridges and other structural work, their life would be indefinite. If corrosion could be eliminated the fatigue of the metal would be its only limiting factor. Protecting the metal work by cleaning and painting is therefore highly important. Cars should be periodically sand blasted all over, as if they were new and just turned out by the manufacturers. If it were practicable to do this systematically and thoroughly, there is no telling how long a steel car would last. Sand blasting

\* Awarded the first prize of \$35 in the Steel Freight Car competition which closed December 1, 1915.



Steel End of the Santa Fe 36-ft. Box Car

hook over the short flange of track, the latter serving as the door guide. The top guide is a 4-in. by ½-in. steel plate which with a 2 3/16-in. filler block is secured to the side plate by ½-in. carriage bolts. Both the front and back door stops are reinforced with steel plates, and cripple posts are placed directly behind the back stop. The door itself is reinforced with two 1 25/32-in., 2.6-lb. Z-bars, one 7 3/8 in. from the top and the other 10 1/2. from the bottom. Security weather strips are applied at the back of the doors. Nailing strips are applied to the inside of the door posts, with hurlap between, to which are nailed the grain doors when the car is used in grain service.

These cars are equipped with the Class A-19-C Minor friction draft gear, Andrews cast steel truck side frame, Camel Company's side door fixtures, Standard Railway Equipment Company's outside flexible metal roofs and the Standard Car Truck Company's truck roller side bearings.

**AUTOGENOUS WELDING IN BOILER REPAIRS.**—Autogenous welding for effecting boiler repairs is convenient in many instances, but its advantages are apt to lead to oversight of the real causes which produce the defects the welding is intended to remedy.—*The Engineer.*

the mill scale from new steel plates is essential to obtain the best results from painting.

Theoretically, there are no weak points in a well-designed steel car, but like all equipment of this character, there is a part which will fail if it is hit hard and often enough. Some of the outside and center sills have cracked and been patched with inside and outside riveted cover strips. Some of the center sills are spreading, due to the buffing stresses. This is noticeable, also, on cars of other roads of similar design. Less important members are also showing more or less distress. We find the cutting and welding torches very handy on this class of repairs.

Steel cars may be strengthened by a liberal use of pressed steel shapes in place of rolled ones. These shapes should be kept as nearly to the standard section as possible, and the weight of these details reduced to a safe working minimum.

Rolled shapes have their advantages, but unquestionably increase the weight of the car, one of the things we are endeavoring to minimize. Holding cars awaiting the arrival of special pressed steel parts is a cause for much complaint. This, however, should diminish as the railroads become better equipped for steel repairs.

### VACUUM CLEANER

The vacuum cleaner, shown in detail in the drawing, was developed by H. J. White, supervisor of car work, Canadian Northern, Eastern lines, for use in cleaning coaches at terminals. Compressed air from the usual service line is used to produce the vacuum.

The essential features of the device are a collector, an ejector nozzle, a vacuum tip and suitable hose and pipe connections to the compressed air line and the vacuum tip. The collector is a special Y-fitting of cast iron, one branch of which is connected to the air supply, and the other to the vacuum tip through a hose of suitable length. The compressed air enters

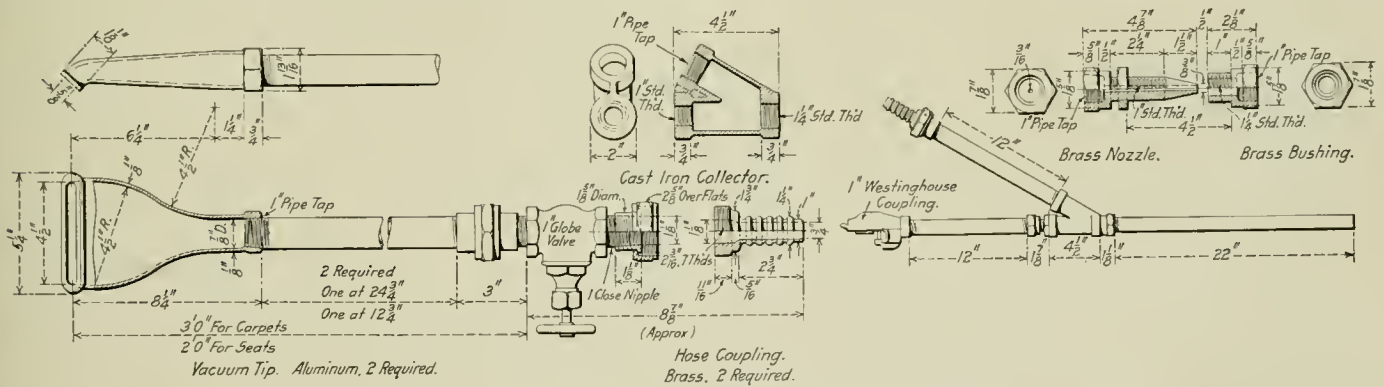

Details of Canadian Northern Vacuum Cleaner for Coaches

the collector body through a 3/16-in. opening in the special brass nozzle shown in detail in the illustration. In the outlet from the collector is placed a brass bushing with a 3/4-in. opening, the inner end of which is located about 1/2 in. in front of the end of the nozzle.

As the small stream of air issuing from the nozzle passes through the bushing it produces an induced current in the suction branch of the collector, which is connected to the vacuum tip. The air and dust which is thus drawn into the collector is blown out through the delivery pipe.

The vacuum tip is secured to a short section of one inch pipe, which is provided in two lengths, one for cleaning carpets and the other for cleaning seats. In order to facilitate changing the nozzles for the two classes of work, a coupling is placed at the upper end of this pipe. Between this coupling and the hose coupling is placed a 1-inch globe valve, by which the suction line may be closed when changing the nozzles.

### FOUR-WHEEL TRUCKS FOR PASSENGER CARS

At the annual meeting of the American Society of Mechanical Engineers, held in New York, December 7-10, 1915, was presented a paper by Roy V. Wright on four-wheel trucks for passenger cars. An abstract of the paper appeared in the November issue of the *Railway Age Gazette, Mechanical Edition*, page 569. The paper was discussed by several members, the following being extracts from the more important part of the discussion:

C. D. Young, Pennsylvania Railroad.—The railroads have been too prone in recent years to use six-wheel trucks, based upon their experience with wooden trucks. Due to the flexure in these trucks, it was necessary to go to the six-wheel truck, simply on account of the wheel load. Obviously, as far as cost, and probably maintenance, is concerned, due to the fewer parts, the four-wheel truck is preferable to the six-wheel truck, provided it gives satisfactory service. With the advent of the steel truck, I believe that the total weight of the car which will be satisfactorily carried on the four-wheel truck can be materially increased. The practicability of this is proved by the use of four-wheel trucks under, say, 98 per cent of the heavy passenger locomotive tenders in this country.

Axle loads as high as 45,000 lb. are permitted on passenger tenders, yet when we design a passenger car it is with fear and trembling that we put 31,000 lb. on the same axle.

In order to ascertain what effect on the train's resistance the two extra axles of the six-wheel truck would have we made three round trips each, with a dynamometer car on a ten-car train, using four-wheel trucks, and a ten-car train using six-wheel trucks, the car bodies being the same in both trains. The difference in total weight per car was due entirely to the difference in weight of the trucks, the cars with six-wheel trucks each weighing 66 tons and those with four-wheel trucks weighing 59 tons each. The tests indicated that the only material difference in resistance was due to the difference in weight of the vehicles. With the cars in question we would have the

same resistance in 13 cars with six-wheel trucks as would be offered by 14 cars with four-wheel trucks.

The development of the clasp brake outlined in the paper was the result of observation of the clasp brakes used on the Philadelphia & Reading. They were tested in 1912, a complete report of the tests already having been made to the American Society of Mechanical Engineers by S. W. Dudley, of the Westinghouse Air Brake Company.\* The single shoe brake had a total weight of 3,682 lb. per car, and the movable parts weighed 3,084 lb. The clasp brake had a total weight of 4,433 lb. per car, the movable parts weighing 2,852 lb., showing an increase in total weight of the clasp brakes of 24 per cent, whereas there is a decrease in the weight of the movable parts of the clasp brakes of 8 per cent. It was developed in our brake tests that it was desirable to have as low weight in the moving parts of the brake rigging

\*See *Railway Age Gazette, Mechanical Edition*, for March, 1914, page 136.

as possible, to overcome the effect of inertia, for obviously the heavier the moving parts the more inertia and the longer time it takes to get full braking pressure at the wheel with a given pressure in the cylinder. By reducing the weight of the parts of the clasp brake we therefore have the right to expect that we develop the full braking power slightly quicker than we do on the single-brake car.

At sixty miles an hour, with 125 per cent nominal braking power, the clasp brake car made a stop in the brake shoe tests in 808 feet, which I believe is the shortest stop ever made on a passenger car under that braking power. The corresponding length of stop with single shoes is about 1,250 feet, showing a distinct gain in the length of stop by the use of two shoes per wheel, with an increase in the total weight of the brake rigging of only about 24 per cent.

The use of the clasp brake is economical in brake shoe material. We have recently made a series of road tests of brake shoes, considering the wear under single and clasp brake conditions. On the five different runs on which the test was made the clasp brake shows a saving in brake shoe material of about 30 per cent as compared with the single brake.

S. G. Thomson.—The Philadelphia & Reading has had 100 cars equipped with clasp brakes in service for a number of years. The brake is very highly efficient; the stops with the clasp brake seem to be very much shorter than where the higher pressures are used to get nearly equal braking power.

G. R. Henderson.—It is well known that the Pennsylvania track is nearly perfect and it is a question whether the Pennsylvania four-wheel passenger trucks would give satisfactory service on average track with the loads which they now carry. The abandonment of the equalizers accounts for considerable saving in weight, as the equalizers and spring seats are quite massive for heavy cars. It is still the practice of many roads to use equalizers under tenders of passenger locomotives and also under high speed electric cars, and it is an interesting question as to just how far we can go in abandoning them and still not interfere with the comfort of the passengers. The condition of the track is a very important factor and should not be overlooked when considering this question.

L. R. Pomeroy.—Six-wheel trucks have been developed more generally in the West than in the East and it is only in recent years that their use has become general on ordinary passenger coaches. This refers particularly to passenger coaches, not sleeping cars or diners or heavy weight cars.

Some of the reasons why the six-wheel truck was applied

TABLE I.—WEIGHTS OF TYPICAL FOUR-WHEEL AND SIX-WHEEL TRUCKS FOR PASSENGER CARS

Road	Type	Diam. and length of journals Inches	Weight of trucks per car Lbs.
Harriman Lines.....	Four-wheel	5 x 9	26,500
Western Pacific.....	Four-wheel	5½x10	31,000
Rock Island Lines.....	Four-wheel	5 x 9	31,120
Barney & Smith built-up truck.....	Four-wheel	5 x 9	27,600
Canadian Pacific.....	Four-wheel	5 x 9	26,400
N. Y. N. H. & H.....	Four-wheel	5½x10	31,400
Harriman Lines.....	Six-wheel	5 x 9	42,000
Rock Island Lines.....	Six-wheel	5 x 9	41,220
Commonwealth Truck.....	Six-wheel	5 x 9	45,900
Pullman Standard.....	Six-wheel	5 x 9	42,720
New York Central.....	Six-wheel	5 x 9	*45,000
Barney & Smith built-up truck.....	Six-wheel	5 x 9	42,000
C. P. R. 70-ft. diners.....	Six-wheel	5 x 9	41,200
C. P. R. 72-ft. sleepers.....	Six-wheel	5 x 9	45,900

\*Equipped with clasp brakes.

to cars which would be considered quite light today were that from 60-lb. to 70-lb. rails with very light gravel ballast, in some cases nothing but gumbo ballast, were used, and further because of the use of cast-iron wheels. At one time the Chicago, Milwaukee & St. Paul was using cast-iron wheels even on parlor cars, these wheels being considered absolutely safe under six-wheel trucks, but not under four-wheel trucks.

The following data has been compiled partly from the columns of the *Railway Age Gazette, Mechanical Edition*, and partly from information furnished by the builders. In Table

I is shown the weight of typical four-wheel and six-wheel trucks. In Table II the weights of typical examples of recent passenger construction. Most of these cars are carried on six-wheel trucks. Allowing 42,000 lb. per car, where the weights of the latter are not known, and 27,000 lb. per car for four-wheel trucks a comparison is made of the actual total weight of each car with the weight had four-wheel trucks been used.

TABLE II.—WEIGHT OF TYPICAL PASSENGER CARS SHOWING SAVING IN WEIGHT BY THE USE OF FOUR-WHEEL TRUCKS

Road	Class	Construction	Weight with six-wheel trucks lb.	Weight of car body lb.	Weight with four-wheel trucks lb.
Wabash.....	60-ft. mail	Steel	124,000	82,000	109,000*
N. Y. C.....	Coach	Steel	142,000	100,000*	127,000*
N. Y. N. H. & H.....	Coach	Steel	131,000	89,000	.....
N. Y. N. H. & H.....	Coach	Steel	.....	90,000	121,400
G. T.....	74-ft. coach	Composite	137,000	97,000	124,000*
A. T. & S. F.....	Coach	Steel	134,000	91,000	118,000*
A. T. & S. F.....	Chair car	Steel	136,000	93,000	120,000*
Jersey Cent.....	Coach	Steel	.....	81,800	115,800
U. P.....	69-ft. bag.	Steel	.....	79,000*	106,000
U. P.....	60-ft. mail	Steel	.....	84,600*	111,600
Long Island.....	Parlor car	Steel	.....	.....	124,000

\*Weights estimated.

There are many cars running successfully on four-wheel trucks that weigh as high as 124,000 lb. The Long Island parlor car of this weight shown in Table II is carried on four-wheel trucks with 5-in. by 9-in. journals, and the load on the projected journal area is only 344 lb. per sq. in.

Under ordinary conditions of service there is no justification for a six-wheel truck under a suburban car, and yet there are a great number of suburban cars which are running on six-wheel trucks. I will go further. I have never yet seen a 70-ft. car of the ordinary passenger coach type where the six-wheel truck was justified with the track we have today.

The following instance is given because of its bearing upon the difficulty from hot boxes. On a certain railroad, where, from the weight point of view, the 5 in. by 9 in. journal was perfectly satisfactory, and they were maintaining their journals in good shape, they were having trouble from hot boxes. They substituted the next larger M. C. B. axle, and still had trouble from hot boxes. An analysis of the situation brought out the fact that with the new form of high-speed brake the pressure with one shoe per wheel was such that it caused the brass to tilt and prevented the proper contact on the journal. When the clasp brake was applied no trouble was experienced with the 5 in. by 9 in. journal.

S. G. Thomson.—We made some tests on the Atlantic City Railroad to determine the cause of hot boxes in very high speed service, up to 80 or 90 miles an hour on some parts of the road. We took some temperature readings of the boxes and found that the trains would come into the terminal with the boxes almost at the flashing point. In the rush season we had to turn these trains back on the reverse trip at once, and no doubt the accumulated heat in the wheels and journals had something to do with the hot boxes on the way back. We ran these trains sometimes six trips during a day and occasionally the boxes would heat up, without any apparent reason, having had careful attention at both ends of the route on all trips. The cars were all-steel, weighing about 118,000 lb., and in my judgment were about at the limit for the four-wheel truck for that speed. We took the same cars on our New York division, where we have a couple of stops, and do not run at such high speeds, and they gave us no trouble whatever. The speed seems to be a factor in the question of using the four-wheel truck, and when our last cars were designed we considered very seriously the use of six-wheel trucks. We concluded to stick to the four-wheel truck and have done so with fairly good results.

G. W. Rink (C. R. R. of N. J.).—I would like to ask Mr. Thomson whether it was with the type of truck with the springs directly over the journal boxes that the trouble with hot boxes occurred. We had a few cars built with trucks of that type, and eventually went to the one-piece Commonwealth truck, be-

cause of trouble from hot bearings. On the trucks without equalizers, having the coil springs placed directly over the journal boxes, there is a tendency for the boxes to tilt and bind in the pedestal, producing uneven distribution of bearing pressure and wearing the box flanges. These trucks weighed 15,200 lb. each and the Commonwealth trucks, which we now use, weigh 17,000 lb. each. Both types of trucks have clasp brakes, with beams across the truck.

S. G. Thomson.—The trucks tested were not the ones with the springs over the journal boxes, although that type has given more trouble than the other type.

### A SUGGESTION FOR COMPOSITE FREIGHT CAR CONSTRUCTION\*

The connection between the wood and the steel center sills is of utmost importance in the construction of wood cars with the steel underframes. Many such cars have been hit so hard that the striking castings were driven through the end sills and the underframe completely disconnected from the car body.

The manner of bolting the two together is largely responsible for this result. In all cases the bolts should pass through both flanges of the channel sills. This more than doubles the strength of the bolts and while it takes longer bolts, the difference in cost is well worth while. In the first place, when the bolts are used in the upper flange only, part of the thread is above the channel in the wood sill. Between the two sills is the point where the bolt should be strongest, but the section of the bolt is reduced by the threads, which nick it sufficiently to cause it to break easily at this point. Furthermore the inner face of the flange is rolled at an angle so that the nut bends the bolt as soon as drawn tight. If the bolt be extended through both flanges its strongest point is between the wood and the steel sills and the nut is drawn up on the lower face of the lower flange, which is perpendicular to the center line of the bolt.

### THE LIFE OF A STEEL FREIGHT CAR†

BY SAMUEL LYNN

Master Car Builder, Pittsburgh & Lake Erie, Pittsburgh, Pa.

In preparing this paper it was decided to get the opinions of some other car men regarding the life of a steel car and I wrote to several friends who have had considerable experience with such cars. Their replies showed that there is quite a diversity of opinion and that a steel car will last anywhere from eight to fifty years.

Years ago while working on the shop tracks repairing the old wooden cars, I can remember distinctly seeing an occasional train of steel cars, or "battleships" as we called them, go by; the repairmen would get together and discuss the question of where they would get their bread and butter when the old wood car finally went to the scrap pile. There are some car department officers at even this late day who apparently feel that the steel car does not require much attention. However, this theory is no longer given much consideration, as any one responsible for steel car maintenance realizes that while the steel car, with its larger carrying capacity, increases the earnings of a road, after the car reaches a certain age its maintenance cost increases over that of the old wooden car. As a consequence there are several things that must be considered when discussing this subject.

*First.*—It seems to me that the problem of most importance is the design of the car. Care must be taken to get the required strength in the underframe in order that the car may withstand the shocks incident to present-day transportation. In addition to a good solid underframe, the draft sills and draft gear must be equally strong to stand up to their work. I have seen new

cars turned out of a car plant and after the first or second loading the draft sills, or center sills extending from the end sill to the front of the body bolster, were so badly buckled that they had to be removed and replaced and reinforcement added to strengthen the weak members; and these cars, although practically new, were useless until the parts mentioned had been reinforced to take care of either oversight or poor judgment in the drafting room. Consequently, too much stress cannot be laid on proper design.

*Second.*—The commodities with which a car is loaded and the climatic conditions in the territory through which it travels are important factors in the life of a steel car. The cars in this territory used exclusively in the coal, coke and ore trade are subject to very severe service, as they are usually hauled in heavy tonnage trains, and the acids in the coal and coke eat through the floor sheets rapidly. In addition to the injurious effects of the acids on the inside of the car, the varying weather conditions—rain, snow and heavy damp atmosphere—play important parts in the deterioration of the car.

As previously stated, at one time a number of car department officers were of the opinion that the steel car required but little attention, and as a result in its early existence even the car inspectors would look over the car primarily for safety appliance defects, hot boxes, etc., and take it for granted that because the car was of steel construction it was all right. For some reason, the steel car from the time it first went into service did not seem to have a friend. At the industrial plants where the cars were unloaded the men took frequent cracks at them with sledges and as a result the side and hopper sheets soon became bent and distorted. During the winter season when ore became frozen in the cars, some of the plants used dynamite to loosen it up and in addition they frequently loosened up the floor and side sheets at the rivets. If the steel car was given reasonable treatment and repairs made when needed, and repainted when the steel became exposed to the weather, the renewing of some of the parts would not become necessary for a longer period than is now the case.

The original painting of the steel car is usually faulty. Owing to the hurry-up methods of the building the required quality of paint is liable to be dryer-sacrificed, or made to fit the building time of the car, without giving the protective qualities of the paint due consideration. I do not want to be understood as saying that paint will cure all the ills of the steel car, but do believe that if a liberal quantity of good paint was used to protect all outside exposed parts, the life of the car would be lengthened considerably. Occasionally we may hear some railway officer use the expression that "a steel car will run and earn just as much money without paint." This may be true, but the question is, how long will it run? I firmly believe that part of the expense necessary on steel equipment today is due to paint neglect. I do not favor painting the inside parts of any steel car—the first loading would cut and mar the paint so that moisture would get under it—but by keeping the outside exposed parts painted, the corrosion of the outside parts of the sheets would be counteracted to a considerable extent.

On hopper cars it has been found that after the first 10 or 12 years' service the floor and hopper sheets deteriorate from  $\frac{1}{4}$  in. in thickness to a very light gage. In fact, along the seams and sides of the cars where the floor sheets are riveted to the sides, in some cases the steel is completely eaten or rusted through, and in order to get any further service from the car it is necessary to renew the floors and hoppers. This has been done on a large number of steel hopper cars at an approximate cost of \$225 a car. After this class of repairs is completed and the cars have been in service for about four years we find that the car sides which were in fairly good condition when the new floors were applied have deteriorated to such an extent that it is necessary to renew the sides of the cars. This work can be done at an approximate cost of \$130 a car, making a total expense of \$355 a car on the car body, exclusive of various light repairs necessary at different times.

While this class of repairs are being made it is found in

\* From a paper by H. C. Priebe, read before the Car Foremen's Association of Chicago, December 13, 1915.

† Abstract of a paper presented at the December meeting of the Railway Club of Pittsburgh.

a few cases that the center sills have deteriorated to some extent from corrosion. They may also have buckled, making the application of new sills necessary. Where new sills are applied on such cars there is an additional cost of \$45, making the total amount spent on the car body approximately \$400. However, on a very large percentage of the cars on which this class of repairs is being made we do not find it necessary to renew the center sills. These sills, in most cases, have been reinforced between the body bolsters and the hopper sheets by a tie plate or channel section riveted to the sills, the cost of this application being included in the estimates already given.

From the above it would seem that the bodies of the majority of the first steel cars built, or cars that have been in service 16 or 17 years, will require repairs amounting practically to the rebuilding of the car body. This rebuilding process, however, occurs at different periods, whereas if all the parts of any unit of equipment deteriorated at the same rate, there would be no question but that the average depreciation could be fixed very closely, as every part of the unit would become worn out at the same time and the whole body of the car would therefore probably be scrapped or rebuilt as a new unit. The present policy of maintaining the steel car as different parts fail is practically the same method as was employed in the maintenance of the wooden car equipment.

It has been the custom of car department officers to estimate the life of the wooden car of either the box or gondola type at 20 years. The old wooden car, during the 20 year period, received at different times repairs such as two or more longitudinal sills, the renewal of the top side plate, new floors, and other repairs which amounted practically to the rebuilding of the car, yet for general purposes 20 years was considered the average life of the wooden car.

Allowing the same treatment for a steel car, that is, giving it general repairs when necessary and properly maintaining the car so as to get maximum service from it, the steel car is still in serviceable condition after it has run 16 or 17 years.

Some mechanical department officers take the position that it is more economical to prolong the life of the car by repairs, while others say it is better, from an economical standpoint, to run the car until it requires repairs such as have already been described as necessary for the car after it has been in service about 12 years, and then scrap the body and place a new body on the trucks. They take the position that when the floors and hoppers are worn out, the balance of the car has deteriorated to such an extent that it is cheaper to scrap the body than to try to maintain it.

The first metal car purchased by the Pittsburgh & Lake Erie has been in continuous service since June, 1897, except for short periods when it was in the shop for class repairs, and is therefore over 18 years old. It is an 80,000 lb. capacity car of the hopper type; has a cubical capacity of 1,286 cubic feet; weight new 35,700 lb.; weight last time weighed in June of this year, 35,200 lb. The car was built of wrought iron by the Youngstown Bridge Company and is in good condition today. The original sills, bolsters, end sills and draft members, as well as the sides, are still on the car. It received heavy repairs in the years 1912 and 1915 at an approximate total cost of \$450. After a close inspection of the photograph I do not believe there is any one present who will say that the appearance of this car indicates that it should go to the scrap pile.

F. W. Dickinson, master car builder of the Bessemer and Lake Erie, advises that their first steel cars, over 19 years old, are in almost as good condition as when first built. The Bessemer and Lake Erie is one of the pioneers in the steel car game, yet Mr. Dickinson advises it is practically impossible for him to make any definite statement as to the probable life of a steel car.

There is one other reason why we should refrain from placing a limit on the life of the steel car, and that is, the steel that is now being purchased and used for repair parts is inferior to the steel that went into the first cars built. While I am not a steel man and know nothing about the business, the fact re-

mains that the steel plates that are being purchased and used for repairs are deteriorating much faster than the original sheets placed on the cars. Whether this is due to the composition of the metal, or to some other cause, I do not know. If this same grade of steel is being used by car builders today on new equipment, and an estimated average life was placed on cars based on the lasting qualities of the material used when steel cars were first built, the steel in the cars that are being built and turned into service today might not last more than one-half the time of the steel in the cars first built, and it is therefore my opinion that we would be doing the steel car an injustice to say that at the end of any stated period it should be relegated to the scrap pile. I believe that the steel car can be maintained as long as the owner desires to run that particular type of car.

## INSPECTING CAST IRON WHEELS UNDER FREIGHT EQUIPMENT\*

BY J. P. YAEGER  
Wheel Inspector, Lehigh Valley

Wheels are guaranteed by the manufacturer for a certain life under fair usage. If they fail to make this guarantee, and have defects for which the manufacturer is responsible, such as worn hollow, worn through chill, seams, shelled out or cracked plates, they are preserved after being pressed off the axle, and at the expiration of the month the manufacturer is given notice; a joint inspection is then made by a representative of the foundry and the wheel inspector to determine what wheels will be replaced. The gentlemen from the foundries are usually "from Missouri;" they want to be shown, and it has sometimes been necessary to put the wheel under the hammer to convince them of the true conditions. This is said with all due respect to the foundry people and simply to emphasize the importance of holding only such wheels as have manufacturer's defects.

### YARD INSPECTION

When cars are received at an inspection point the car inspector should make a careful examination for wheel failures, confining himself to M C B Rules 68 to 83. He should also be familiar with the serious results that arise due to wheel defects if allowed to run.

*Worn Flanges.*—The flange directs the truck, and therefore one flange or the other is in almost constant contact with the rail and subject to friction or grinding under considerable pressure. This is especially true when traversing a curve; the continuous grind in the absence of lubrication results in flange wear. Worn flanges are the cause of many derailments in the yard. If the point of the switch is worn, or there is a slight opening at the point, between the two—the worn flange and switch point—a dangerous combination is formed, and the wheel, owing to its worn condition, mounts or splits the point, and the result is a costly derailment.

*Broken Flanges.*—These are mostly due to seams which develop below the surface of the metal. They cannot be detected until the surface metal is broken through. I have usually found this defect to exist on wheels under the heavier class of equipment; when striking a curve about two-thirds of the flange breaks off. It is my understanding that when the iron is poured into the mould it first fills the lower part of the hub, then travels through the bottom plate and brackets, filling up the flange. The section of the mould forming the flange is thin and the upper part is formed by the metal chiller. It will be readily seen that the metal in the flange will be cooled somewhat by passing over the cold sand of the mould and coming in contact with the chiller. The more rapid cooling and contraction of the metal in the flange, as compared with that of the tread, tends to cause a separation or seam. As previously explained, this is an inherent defect and develops much quicker on the higher capacity cars, for the reason

\* From a paper read at the August, 1915, meeting of the Niagara Frontier Car Men's Association.



that, contour and conditions being alike, the friction due to the increased load brings it about sooner.

*Wheels Slid Flat.*—It is an easy matter to distinguish this defect from worn through chill by observing the fine hair lines which are caused by the separation of the chill due to the friction between the wheel and the rail. This is a delivering company's defect and must be charged on a defect card when received from a connecting line, or the charge must be absorbed as a "no-bill" when occurring on the handling line.

*Wheels Worn Hollow.*—The amount of wheel wear on the tread to warrant its removal from service is left largely to the judgment of the inspector. A good interpretation of M C B Rule 76 should provide for wheels being removed when worn sufficiently to permit the rim to project far enough below the top of the rail to render it liable to breakage when passing over frogs or crossings, or when the flange becomes so high that the apex is likely to strike the bottom of flange-ways. It is the practice in track work to allow a minimum of  $\frac{5}{8}$  in. for flange clearance at the bottom of flange-ways in frogs, crossings and guard rails. This allows the tread to wear down  $\frac{5}{8}$  in. before the flange strikes the frog and crossing filler. The minimum amount a wheel shall be worn hollow is not specified, but is generally conceded to be  $\frac{3}{16}$  in. In the Master Car Builders' proceedings for 1905 it was recommended that wheels be allowed to wear down  $\frac{3}{8}$  in. before condemning them, unless worn through chill. Wheels of the ordinary taper can become worn  $\frac{3}{8}$  in. from the original contour at the throat before they become worn  $\frac{3}{16}$  in. hollow on the tread.

*Brake Burn.*—In brake-burnt wheels the tread is broken up into fine hair lines running parallel across the tread of the wheel, generally covering a considerable portion of the circumference; if kept in service, the continuous pounding causes the metal to drop out little by little, resulting in a comby condition of the wheel tread.

*Shelled Out.*—This refers to spots where the metal has dropped from the tread in such a way that a raised spot is left in the center with a cavity more or less circular around it.

*Broken Rims.*—These are usually due to wheel being worn hollow or having seams or hollow rims.

*Worn Through Chill.*—This is a manufacturer's defect and can often be discerned by the appearance of the tread and the manner in which it is worn. If worn irregularly, *i.e.*, deeper at some places than at others, or if worn flat, it is evident that the chill is destroyed. By breaking the flange at a point where the wheel is worn it is an easy matter to determine the amount of chill left in the wheel. If the wheel was slid it would make itself apparent by discoloration of the chill.

It must be understood that the maintenance of wheels involves a large amount of money, and an over-zealous inspector can divert to the scrap heap many wheels that have not outlived their usefulness. It therefore behooves each one of us to use his gage with discretion, so that each wheel may perform its proper duty in the mileage that is expected of it.

## FINISHING CAR JOURNAL BRASSES

In order to provide a smooth bearing on new re-babbitted car journal brasses and thereby eliminate the heating of the journals when new brasses are first applied, the Great Northern has in service at the Dale street (St. Paul) shops the belt-driven milling machine, shown in the accompanying illustration. The milling cutter finishes the face of the bearing and rounds off each end to the proper radius. The brass is held in jaws operated on the toggle joint principle and is forced into the milling cutter by the air-operated plunger shown under the machine. The method of operation is as follows: The brass is placed in the jaws of the machine and the air pressure is applied by turning the handle *A* to the left. The plunger *B* is then raised, closing the jaws tightly onto the brass and at the same time moving them with the brass upward and onto the milling cutter.

A special clutch is also provided, which throws the milling cutter into action as soon as the air is applied to the plunger. The air pipe *C* with a push button valve is used to blow away

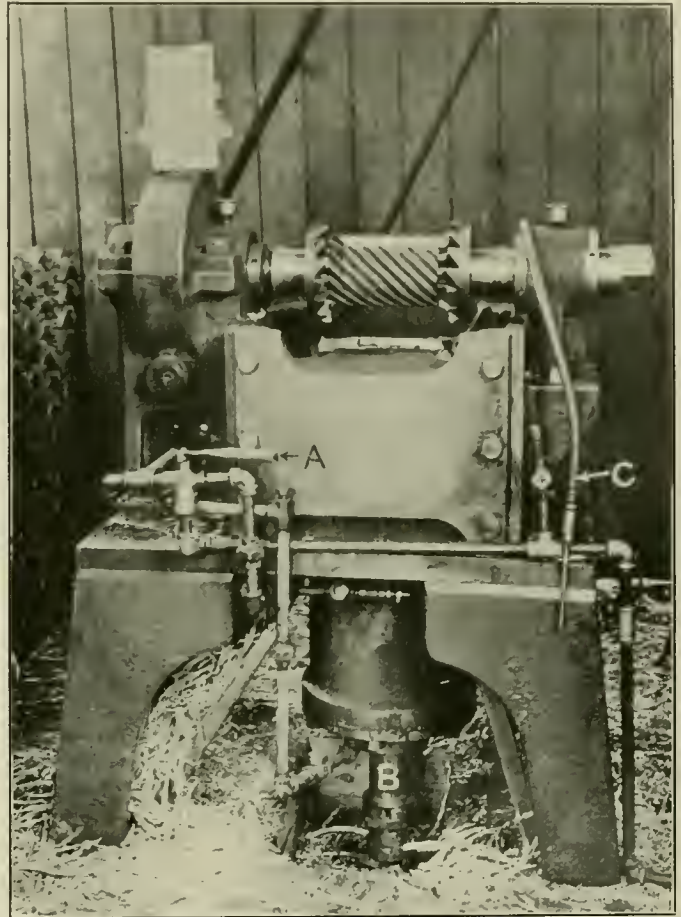

Milling Machine Used in Finishing the Bearing Surfaces of Journal Brasses

the babbitt shavings after each operation. A finished brass is shown on top of the gear box at the left. This machine was made at the company's shops from scrap material.

## MAKING EFFICIENT CAR INSPECTORS\*

BY HARVEY DE WITT WOLCOMB

The car inspector's relationship to a railroad is the same as a traffic policeman's relationship to a large city. Their duties, though widely separated, have several features in common. The car inspector works under far more dangerous conditions and his surroundings are not as pleasant as the traffic policeman's, yet he should perform his duties with the same thoughtfulness and painstaking care as if he were stationed on one of the most prominent streets of any large city.

To secure faithful and loyal service under the most trying conditions is a sure indication that the training has been along the right lines and the cost of this kind of training soon repays the investment; the first step to be considered in the selection of a future car inspector is not his training, but his qualifications, for some men receive the very best of training, yet fail when it is put up to them to properly apply the many rules and regulations they have been taught, or how to handle themselves when placed on their own resources. In order to avoid wasting time and money on this kind of a man, prospective car inspectors should be examined to see if they have the "foundation" to build on.

The very first point to be settled is whether the man is physi-

\* Entered in the Car Inspector's Competition, which closed October 1, 1915. For prize article see November issue, page 575. See also December issue, pages 624, 627 and 628.

cally perfect, or in other words, has he a constitution strong enough to stand working outdoors in all kinds of weather and to stand the sudden changes of weather without complaint, for car work must be handled in all sorts of weather and train schedules must be strictly adhered to. This question can be easily answered by an examining physician. The next question is whether the man is regular in his habits. Is he reliable, for when a man promises to come to work at 7 a. m. and does not report until near 8 a. m., he is not reliable; one of the most important requirements of a good inspector is his reliability. In fact, the railroad depends on the inspector's word in the same way as we depend upon the word of the president or cashier of a bank.

The foreman selecting a man to be trained for a car inspector should know that he is of the observing type and will not lose his head in exciting times. Observation plays an important part in the success of an inspector, and while it may not be developed to a great extent at first, it will be developed by actual experience.

The last two qualifications are easy to investigate and while they seem insignificant, if not noted before training a man, the entire training may be wasted by either one of these traits. They are the man's home life and hobbies. Several large industrial organizations have found it beneficial to investigate the home life of their employees and in the case of a car inspector, I believe it is an absolute requirement. We cannot expect much in the way of study from a man who never remains home nights, but who is out late attending "lodge" or some other social function. Such a man will not have time to study his rule book and besides his rest is broken so that he will not be physically able to concentrate his mind on his work. If a man does not have time to read the papers at home evenings, it is a safe bet that he will neglect his work the next day to get enough time to read at least the baseball news. Home life has a lot to do with the success of any job.

"Hobbies" have spoiled many a man's chances. It is only necessary to talk to a man a few minutes to find out if his mind is on one thing only, or if he is broad enough to see some good in all things. You may say that you would expect your car inspector to have one "hobby," and that is "car inspection," yet it is possible to have this overdone as an athlete sometimes over-trains. My interpretation of the word "hobby" may be peculiar; I mean, for instance, do not place a German and Englishman together inspecting cars and then wonder why they neglect their work to talk war. Try to carry on a conversation with a traffic policeman when he is in the center of a busy thoroughfare and note the answers you get. He will be civil and polite but will soon turn you away, for his mind must be on his work and, if his attention is attracted otherwise, traffic will soon become blocked. Your car inspector should be the same.

#### TRAINING

Training should start in the office work, for we demand accurate reports from our inspectors, and I do not believe any man realizes the importance of making good, neat and accurate reports until he has tried to handle office work. Very often important law suits depend on the word or record of a car inspector and unless he shows he understands what a record is or how it should be kept, his word is useless. I have known inspectors to keep a book record of the days it rained, or the date of the first snow fall, or some other such common, every day happenings. Then again, office work develops what records to keep and how to keep them as briefly as possible. Keeping note or book records can be overdone by trying to keep a record of too much, and office training is invaluable to get a man started right in this respect.

Following office training, the man should be given a careful course in observation, for on observation depends the success of good inspection. A head inspector whose duties should consist of instruction only, should get in touch with every inspector and talk with him about his work. Today we find that men who are

supposed to go over a railroad and instruct the different inspectors, imagine the success of their jobs depends on how many foremen or inspectors they can "write up" for little things that get by them. To my mind, the ideal chief inspector is a man who seldom writes letters and then of praise only, yet can point to the good inspection that is being carried out by the men on his road.

Aim to keep your inspectors satisfied, for it is well known that a satisfied man will do far more work than one who has a grievance. The lot of a car inspector is bad enough at the best and we should watch to better the conditions wherever we can. Inspectors should be sent on little trips to other points to see the conditions under which other men have to work. If the conditions at other points are better than their own, then it will act as an inducement for them to "tidy" up or make a just request to have some conditions corrected. If on the other hand, they find conditions much worse than at their own place of work, they will return with a greater appreciation for their home and be more satisfied.

The heads of the departments should keep in touch with the inspectors by getting out in the car yards and meeting them "as man to man." Imagine how pleased an inspector would be to have "the Old Man" come down to the car yard and thank him for a nice report or good inspection record. Do you know of any more profitable time spent than a little "heart-to-heart" talk by the superintendent of the car department with a number of inspectors, letting them know that by their close attention and good work the company had saved money—that the average wreck cost so much money and that as there had not been any wrecks in the past year, approximately so much money had been saved. Write a nice little article of praise and publish it in the company's magazine or in the town paper, for any man likes to see his name in print, particularly if it is the result of his good work.

Offer cash prizes for good work, or for some specified results, for as a rule the car inspector's pay is not very liberal and if he can increase his earnings by closer attention, he is bound to do so. As a grand prize, offer to take the inspector to the Master Car Builder's convention if he meets certain requirements. Every car inspector in the United States would like to attend one of these conventions and see for themselves just how the car rules are gotten up.

As to the correct use of the many rules that govern car work, it is a sure bet that the inspector cannot repeat the rules, word for word, but he should be examined occasionally to keep him from getting rusty. I know of a certain head inspector that will sometimes go to one of his inspectors and ask his advice about a certain question that has come up. The head inspector will act as if he was "floored" and needed advice. The chances are that the inspector will get so interested that he will not stop at this one case but will study his rule book from the front to the last page.

As to working conditions, the car inspector is a human being and can be coaxed better than driven. You cannot ask a man to walk three miles down through a car yard and then expect him to give you high efficiency. He has wasted a lot of energy in the walk that should be put into his work; it is a good thing to see that the inspector is taken to and from his work, when such arrangements can be made at a nominal cost. You do not expect to get the full rating from a locomotive when the steam pressure is only half of what it should be, so do not expect your inspector to use half his energy to overcome some unnecessary disadvantage and still give you perfect efficiency.

Car yards should be kept clean so that inspectors will not be liable to trip and fall. The inspector's mind should be concentrated on his work. Avoid having him climb up or on cars, for when he starts to climb his mind is taken off his work and he loses the benefit of his previous close attention. Furnish him with car construction books and good reading on his work, so that if he has any idle moments he can put in the time to good advantage.

# SHOP PRACTICE

## EFFICIENT RECLAMATION OF BOLTS AND NUTS

BY E. T. SPIDY

Assistant General Foreman, Canadian Pacific, Winnipeg, Man.

No material is more generally used in the maintenance of railway equipment than bolts, nuts and washers. The annual expenditure for these commodities is very large and the question of scrap reclamation is an important one. The Canadian Pacific has maintained a reclamation plant at the Winnipeg shops for several years, and this plant has always shown itself to be a paying proposition. In order to increase the output of the plant, however, a careful study of its operation was recently

therefore, largely devoted to the latter phase of the problem. An important factor in the cost of handling is the location of the plant. This did not enter into consideration in the present instance, however, because the plant was already located in a building adjoining the main scrap dock, a very convenient location.

The handling of material such as bolts and nuts is a matter of especial importance, because of the small size and comparatively small value of the pieces, each of which must be handled separ-

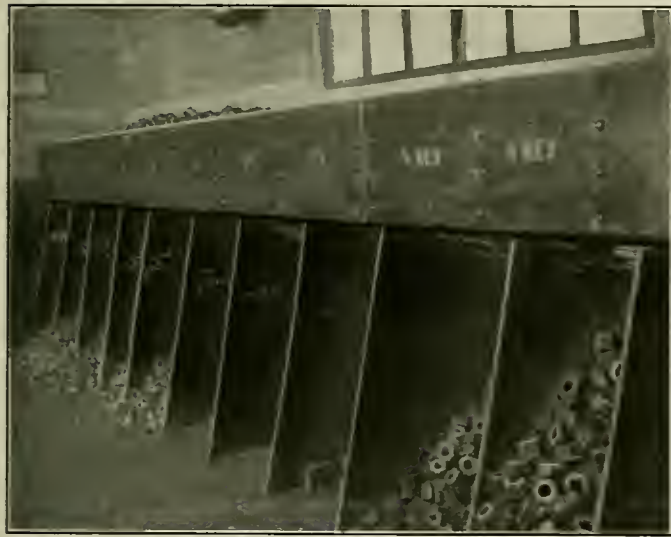

Exterior View of the Nut Storage Bins Showing Additional Storage Capacity Below the Main Bins

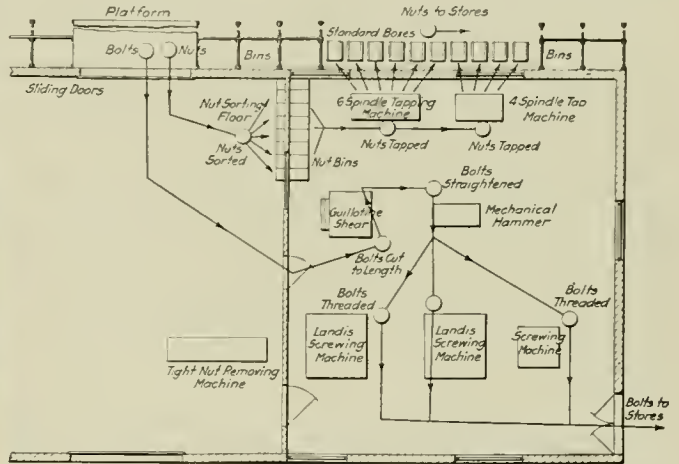

Arrangement of Canadian Pacific Bolt and Nut Reclamation Plant

ately in some of the operation. If handled more than once to complete a single operation, the total cost of reclamation may be considerably increased. The following system was developed in order to eliminate all unnecessary handling and as far as possible to handle the material in quantities. The entire system is based upon the use of a so-called standard box. This box is built up of 3/16-in. plate with 1-in. by 1-in. angle irons at the top. The box is 24 in. long by 15 in. wide by 12 in. deep, and is moved about the shop by means of a special truck shown in one of the drawings. The truck is so designed that one man can readily

made, with a view to improving conditions without a large money expenditure.

The following is a complete analysis of the essential operations in the process of reclamation:

### BOLTS

- Collected from various sources
- Sent to the reclaiming plant
- Sorted for length and size
- Cut to serviceable lengths
- Straightened
- Threaded
- Delivered to stores or shop.

### NUTS

- Collected from various sources
- Sent to the reclaiming plant
- Sorted for size
- Retapped
- Delivered to stores or shop.

### WASHERS

- Collected from various sources
- Sent to the reclaiming plant
- Cleaned
- Delivered to stores or shop.

These operations divide themselves into two groups—machine operations and handling. The machine costs are usually well known and may be determined without difficulty. The cost of handling, however, is always more or less indefinite and is much less readily determined, since there are so many variable conditions effecting the efficiency of handling. The investigation was,

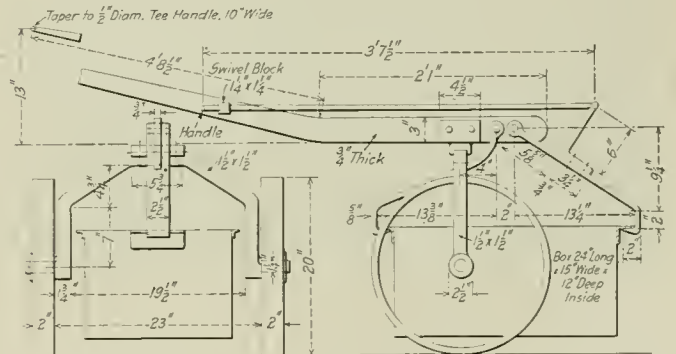

Special Truck for Movement of Material in Standard Boxes

lift and handle a load of 600 lb., which is about the average load of bolts or nuts handled. All movements of material through the plant are made in these boxes with the special truck which is so constructed that it may be wheeled over a loaded box and the hooks dropped over short angles riveted to each end of the box for that purpose. The hooks are controlled by a rod, the handle of which is placed near the handle of the truck. The box is then lifted by pulling down the handle to a position convenient for pushing the truck. In this position the weight of

the box is balanced, the bottom clearing the floor by about two inches.

The location of the machines and the routing of the material from the time it is received for sorting until it is delivered to the stores is shown on the plan of the shop. Bolts are received on the track adjacent to the platform. They are sorted in the car, or at the door of the car, each size being handled directly into a standard box, to be dumped into one of the bins shown against the outside of the building. The sorted bolts are stored in these bins until such time as they are required in the shop. The location of the bins is such that the distance to be traveled when taking bolts into the shop is reduced to a minimum. With the single handling thus required, two laborers are able to do all the sorting.

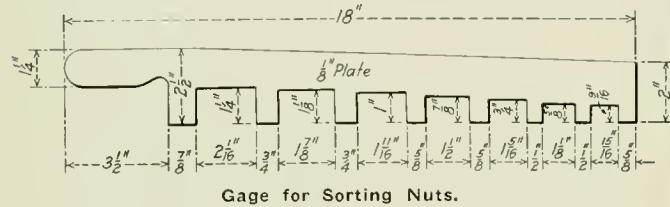

As required, bolts from the bins are taken in standard boxes to the bolt chopper in the shop. The operator of this machine takes the bolts from one box, cuts them to the lengths required, and places them in another box on the other side of the machine. When filled this box is moved by the trucker to the straightening hammer. This is a light machine capable of striking a 75-lb. blow. With this machine one man can supply three triple-head treading machines, whereas with the hand hammer method of straightening, one man was required for each machine. From the straightening hammer the boxes are moved to the threading machine where they are taken from one box directly into another, as previously described.

When threaded, the bolts are near the delivery door of the shop, through which they are moved to the storehouse. On

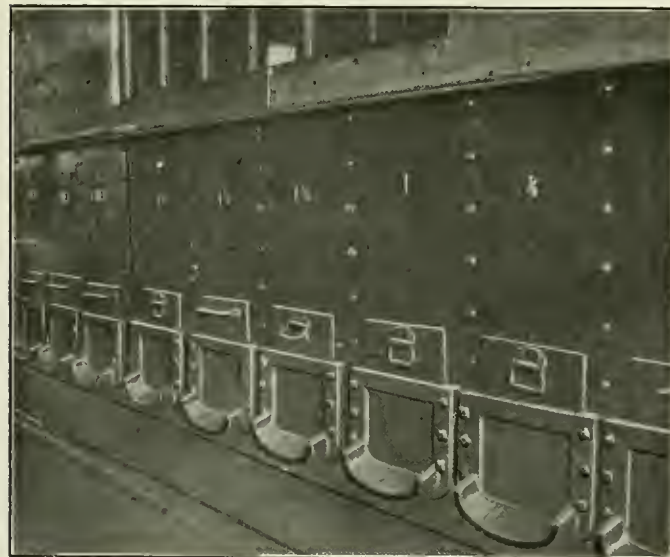

View of the Nut Storage Bins from the Interior of the Shop

reaching the storehouse the bolts remain in the boxes until they can be placed in the storehouse racks. It will be seen that the material is moved forward throughout the process of reclamation, and the only direct handling is that which is absolutely necessary in sorting, placing the bolts in the machines, and finally placing them in the store racks. All other movements are made in bulk.

The system of handling nuts is generally similar to that of handling bolts, although some of the details are necessarily different. The nuts are received in the shop building for sorting, special sorting bins being built into the wall separating the machine shop from the remainder of the building. These bins are clearly

shown in one of the photographs and are located near the tapping machines. The nuts are sorted outside the shop and thrown into the proper bins, from which they may be removed within the shop as required.

Many nuts are scrapped which cannot be removed from the bolts because of jammed thread or rust. On the scrap platform



Delivery Chutes from the Nut Tapping Machines

and at the freight car shops, the two principal sources of supply, air operated shears are maintained for the purpose of cutting off the ends of such bolts. These bolt ends, which are left as long as possible, are taken to the tight nut removing machine. This was built from an old 20-in. lathe on which a special chuck had been placed to facilitate the removal of tight nuts.

The practice of allowing a tapping machine operator to be surrounded by many boxes of nuts which he removes in handfuls to the machine table has been eliminated. Each operator is provided with a bucket holding about 100 lb. of nuts. This quantity he draws from the bins as required, emptying them into the small table bins which hold about 100 lb. per spindle. As the nuts are tapped they mount the spindle. They are removed from the spindles by the operator and allowed to slide off the tap down chutes at the back of the machine. These chutes pass through the outside of the building, each delivering into a stand-

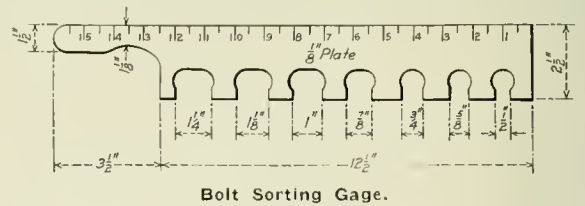

ard box. When the boxes are full a laborer replaces them with empty ones, and the full boxes are then taken to the storehouse or delivered to the shops.

Washers are received at the scrap dock in considerable quantities. They are sorted to size directly into a row of standard boxes, to be cleaned in a rattler and further sorted according to condition. New washers are made from old tubes rolled flat as well as from other scrap material, and are always cleaned in the rattler to remove rust.

The use of the special truck and standard boxes is almost unlimited. In our bolt plant all newly manufactured bolts and rivets are placed in these boxes and handled direct to a flat car by a monorail carrier, to be unloaded at the store's platform by means of the truck. This truck is also used to transport car and other brasses from the stores to the rebarbbiting plant, a special cage or open platform being substituted for the standard box in this case. While a large number of the boxes are required, they may be made from scrap material at a low cost, and the saving effected in the handling of small material very rapidly offsets the initial expense.

## RADIAL DRILL CHUCK FOR LOCOMOTIVE CYLINDERS

BY R. J. HICKMAN

A chuck for use on the base of a radial drill when drilling locomotive cylinder castings, is shown in the drawing. The device is designed for use with piston valve cylinders and the casting is swung about the axis of the valve chamber. By revolving it about this axis, any adjustment of the cylinder may be made to provide for the drilling of all holes at right angles to the axis of the bore.

The cylinder is carried on cone centers shown at *A* and *B* in the drawing, which are mounted on the head stock *C* and the tail stock *D* respectively. The head stock and tail stock are heavy iron castings which are mounted on cast iron bases *E*, the latter serving to raise the centers the required distance above the base of the radial drill. The tail stock is fitted with a lead screw and clamp of the same type used on lathes; the hand-wheel *F* operates the lead screw and serves as a means of adjusting the distance between the cones when clamping the cylinders in place.

Cone *A* may be revolved about its axis in either direction by means of the handwheel *G* and a gear train. To a flange at the base of the cone is secured a driver plate which is bolted

mounted directly upon the radial drill base, thus keeping the cylinder at about the same height as when swung about the axis of the valve chamber.

## GETTING THE MOST OUT OF TOOLS\*

BY B. W. BENEDICT  
Director Shop Laboratories, University of Illinois

The problem of getting the most out of tools\* is larger than the selection of the tool itself, as a number of factors enter into it. The function of a tool is to produce work. Obviously a tool has no power within itself to do this—it is not a force but a medium through which a force works upon some object. Consequently the elements of force and material must receive equal consideration with the tool. Production is a three-sided problem of: (a) the worker as the producing unit; (b) the material as the unit worked upon; (c) the equipment as the unit worked with.

Unless these elements have an effective working relationship the final results will not be acceptable even though the various elements possess individual merit. Good tools must go hand in hand with efficient methods.

The essential difference between well organized and unorganized industry is that in the first the management assumes the

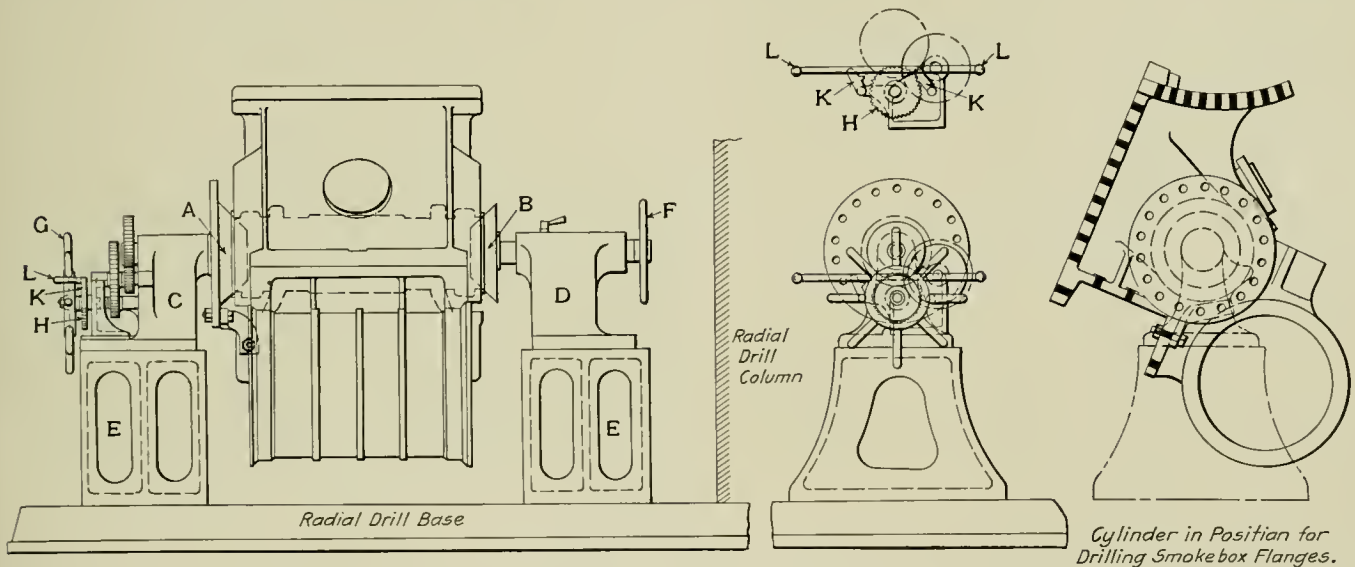

Radial Drill Chuck with Cylinder in Place

to the cylinder, causing the latter to revolve when the cone is revolved. Thus any portion of the cylinder casting may be brought into position at right angles to the drill spindle, where it is clamped by means of a ratchet and pawl device. The ratchet wheel *H* is rigidly mounted on the shaft of the operating wheel *G*. Two pawls *K*, one mounted on either side of the ratchet wheel, engage the latter and are attached to a handle *L* in such a manner that when one pawl is engaged, the other is simultaneously disengaged from the ratchet wheel. Which of the two pawls is to be used depends upon how the weight of the cylinder balances in any particular position. As the excess weight is shifted from one side of the vertical center line to the other, the position of the pawls must be changed by means of the handle *L*. The reduction gears facilitate the movement of the cylinder by hand.

By carrying the cylinder on the axis of the valve chamber bore, the weight of the casting is very well balanced, and comparatively small cones may be used. It is possible, however, by using large cones, to mount the casting on the axis of the cylinder and this practice is followed when slide valve cylinders are to be drilled. When used in this manner the head and tail stocks are removed from the castings *E* and

responsibility of operating the plant and in the second the management throws this burden upon the worker. If a job is assigned to a worker without definite operating instructions, good tools and proper materials, clearly the responsibility for getting out the job is put squarely up to the worker. Under such conditions the worker performs the work in his own way and with such tools as he is able to muster. If on the other hand the management has determined the best methods for performing the work, the worker proceeds along definite and efficient lines which are stamped with official approval. Inefficiencies in the shop, high costs of production, low quality of work done are chargeable to the management and not to the worker. Efficiency has its beginnings in the office—it does not originate in the shop and work backward, to the office. The worker follows the course mapped out for him—if it is efficient he is efficient or out of a job. On the other hand if the central ideal is low and the conceptions narrow the worker will not rise above an inferior performance. Getting the most out of tools is a problem of management.

Of the three elements of industry mentioned previously the

\*Abstract of a paper presented at the seventh annual convention of the American Railway Tool Foremen's Association, held in Chicago, July 19 to 21, 1915.

worker undoubtedly is the most important from every standpoint. Tools always will perform the functions required of them by applying the rules that govern their use. But the worker introduces an entirely different series of problems that are not susceptible to the same certain treatment. The human being cannot be standardized like materials or tools nor controlled in the same manner as inanimate things through the medium of concrete laws. But on the other hand working forces respond very readily to control based on an understand-

come from other localities and other shops where different ideals and methods prevail. The task of the manager is to harmonize the various practices and methods which are thus imparted from many quarters, with the established practices of the shop. This cannot be accomplished without the aid of definite written standards. Verbal instructions and orders are not at all sufficient. Standardized shop practice arranged in the form of instruction cards for the guidance of the worker will insure uniformity and efficiency in the performance of shop operations. A typical instruction card is shown herewith. It is in reality a written order from the foreman explaining how to perform the work. It eliminates the costly efforts of the worker who does not know and increases the efficiency of the more intelligent worker. Accurate and explicit working instructions are essential to efficient shop operation.

The worker is a human machine which does its best work only under conditions favorable to physical, mental and moral well being. Neglect these factors and loss in efficiency is sure to result. Men cannot work efficiently in an environment that lacks the essential elements required by human beings. Poor ventilation causes lassitude from excess of poisonous gases in the air. Excessive heat or cold lowers vitality. Bad water is a very active cause for ill health and disease. Filth, untidiness and accumulated rubbish make slovenly workmen. Gloomy interiors make gloomy workmen. Insufficient natural and artificial light reduce efficiency through eye strain and lack of light to work by. Poor and inadequate toilet and wash-room facilities cause disgust and disloyalty.

Materials are detained certain periods of time at machines while in the processes of production. This detention is unavoidable, but all the time materials are not being worked upon is lost time in so far as output is concerned, as no productive work is done in this interval. Unless some method is employed to direct the course of materials through the proper channels in the shop and without loss of time, production will be curtailed and shortages of finished parts develop during the assembling process. Materials must be despatched through the shops if such conditions are to be avoided. Despatching is accomplished by establishing manufacturing routes for the various parts and moving these parts on schedule over these routes as successive work operations are completed. The simplest method of despatching is from boards which show graphically the location of each part in the shop. Used in connection with the established production route the movement of parts can be definitely controlled. Maximum production is impossible without systematic despatching.

The third and last important factor in production is the equipment or the medium through which force is employed to change the form of material. Naturally the tool is the last link in the industrial chain as it is only after the worker is available and the character of the materials known that it becomes possible to determine the proper tool to use. The tool problem embodies three elements, namely: (a) selection of the proper tool for the work; (b) maintenance of tool in efficient working condition; (c) manipulation of the tool by efficient methods.

Selection entails a study of the work to be performed on each article or part for the purpose of determining the most effective tools of production. Selection eliminates the poor tool entirely without an expensive and disappointing trial period. A good tool in poor shape will not produce results. Maintenance of tools is a very important item in production. It cannot be neglected without loss in efficiency. The first requirement in an effective maintenance policy is adequate tool and tool storage rooms. In the latter suitable facilities for orderly and convenient storage of tools is of prime importance. The average workman has improper conceptions about methods of grinding and upkeep of tools. More and better work will be secured from tools by having them ground and repaired in the tool room than by the individual workman. Machine grinding is superior to hand grinding. Defective tools should be repaired before returning to storage racks to avoid possibility of re-issue

FORM 154 <b>A</b> INSTRUCTION CARD SHOP LABORATORIES MACHINE DEPT.		STOCK NO R 24	PATTERN NO 1-9
<b>24-2</b>			
CRANKSHAFT CENTER BEARING SUPPORT PATT NO 1-9 OPERATION NO 2-4 TOTAL OPERATIONS			
MACHINE DRILL PRESS MACHINE NO. 123			
TOOLS 2 MAGIC CHUCK 3/8 DRILL 7/16 DRILL "RR" SOCKETS		CH 131 DR 209 DR 2013 SO 318	
JIGS. DRILL FIXTURES		Ji 24 2	
ITEM	OPERATION ROUTINE	STANDARD TIME	
1.	Place Magic chuck in spindle of Drill press and insert 7/16" drill. Par. ...	0.01	
2.	Adjust speed. Speed No. 1. Par. ...	0.01	
3.	Clamp jig to platen of drill press. Par. ...	0.02	
4.	Place crankshaft center bearing support in position for drilling. Par. ...	0.01	
5.	Drill two 7/16" holes. Par. ...	0.04	
6.	Remove 7/16" drill from Magic chuck. Par. ... (Do not stop drill). Place 3/8" drill in chuck. Par. ...	0.01	
7.	Drill two 3/8" holes. Par. ...	0.04	
8.	Remove part from jig and place in tote box. Par. ...	0.01	
9.	Remove Magic chuck and drill from drill spindle. Par. ...	0.02	
Standard time in lots = Total pieces $\pm$ 0.11 + 0.06			
<b>TOTAL STANDARD TIME</b>		<b>0.17</b>	

Typical Instruction Card

ing of the aims, desire and nature of the human being. There are four factors that bear directly on the efficiency of the worker namely: (a) Selection; (b) Supervision; (c) Instruction; (d) Environment.

Workers have not been selected but hired. As a result a comparatively small proportion of workers are filling positions they are particularly fitted for—the large majority are misplaced and rendering indifferent service through no actual faults of their own. In the same way as science is employed in selecting the right materials it must be called upon to aid in placing each worker where he can do his best work.

Competent leadership is one of the essential factors in efficient operation of the shop that is not given the attention it deserves, although its importance is everywhere recognized. Leadership is not the exercise of driving power but of ability to incite and direct men in conduct and achievement. Every shop foreman thoroughly versed in his work, honest, fair minded, industrious and progressive, will assume natural leadership over his men. The worker will loyally support the foreman who is mentally and morally competent to assume leadership but he refuses that support to an inferior. His judgment furthermore in this matter is unerring—you cannot mislead him.

In the absence of definite instructions the worker employs methods that he has previously acquired through training and observation. Whether these methods are good or poor depends upon circumstances which hitherto surrounded the worker. Only a few workmen out of the total are home trained. Most of them

to shop when in that condition. Standard tool dimensions, cutting angles, hardness, etc., should be established and constantly maintained to secure consistent performance from tools in the shop.

Getting the most out of tools is a complicated but not a mysterious problem. Its details are many but its underlying principles few and clearly defined. The first by their multiplicity obscures the solution but the latter by their simplicity points the way to its successful conclusion.

### MAKING BOTTOM BRAKE RODS WITHOUT WELDS

BY WALTER CONSTANCE

Blacksmith Foreman, Reclamation Plant, St. Louis & San Francisco, Springfield, Mo.

At the Springfield, Missouri, reclamation plant of the St. Louis & San Francisco, there is a large accumulation of continuous draft rods 1½ in. in diameter, some of which have been used in making bolts, brake mast steps, etc. In seeking other uses for this material the manufacture of bottom brake rods was considered, and the practice herein described was developed. The entire rod is made from one piece stock, without welds, the jaws being formed on a two-inch Ajax forging machine.

Three sets of dies are used in forming the jaws. Referring to the illustration, the upsetting dies by which the stock for the jaws is gathered, are shown at *A*. In the ends of the plungers used with the upsetting dies are placed inserts of tool steel which

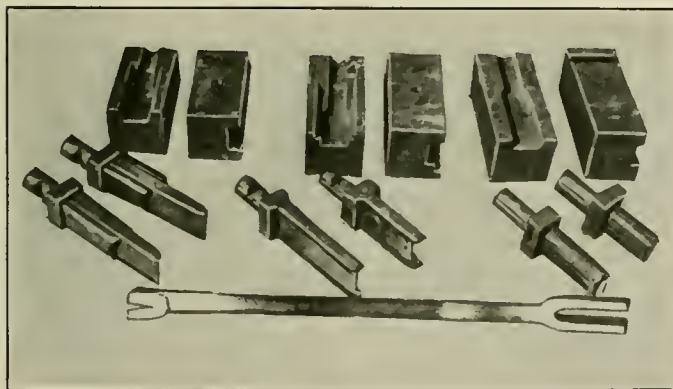

C Dies Used in Forming Brake Rod Jaws from Solid Stock

mark the end of the stock for the splitting operation. One long and one short plunger are provided for single-hole and double-hole jaws respectively. The splitting dies are shown at *B*. It will be seen that they are fitted with grooves at the sides of the opening, in which fit the guides on the plungers. The plungers are thus centered and relieved of any tendency to bend. At *C* are shown the finishing dies in which the jaws are shaped after being split. Two plungers are used, one for the single-hole jaws and the other for the double-hole jaws.

In making these brake rods the stock is first upset and at the same heat is placed in the splitting dies, the jaws being partially split with the short plunger. With the second heat the rod is again put in the splitting dies and the jaws separated to the required depth with the long plunger; the rod is then placed in the finishing dies, the jaws being shaped and the ends finished. Owing to the small size of the machine available for this work, it was found impossible to use the long plunger to start the splitting of the jaws. For this reason a short tool is used to start the split, which is finished with the full length tool. The rod shown in the illustration is finished at one end, while the other shows its appearance after the completion of the first operation.

With these tools the scrap iron rods are produced at a cost

lower than that for which they can be purchased or made by any other method. Furthermore, the rods are entirely free from welds, either in the jaws or body, a fact of considerable importance from a service standpoint.

### EXPANDING MANDREL FOR TURNING LOCOMOTIVE TIRES

BY E. J. BREWSTER

General Foreman, Chicago & North Western, Chicago, Ill.

With the rigidly enforced limits of tread and flange wear now quite generally adopted it is often necessary to turn locomotive driving tires one or more times between shoppings, and the practice of removing the tires without removing the wheels from the engine is followed on many roads. After the tires are removed it is often necessary to shrink them on wheel centers before turning them in a lathe. Several devices have been developed to eliminate the necessity of shrinking on the tires, using set screws or taper keys to hold them in place on the wheel centers. All such devices, however, have a tendency to draw a thin tire out of shape, leaving low spots at points of support after it is turned. With such devices there is also a tendency for the tire to move on the arbor under heavy cuts.

To overcome these difficulties and to facilitate the mounting

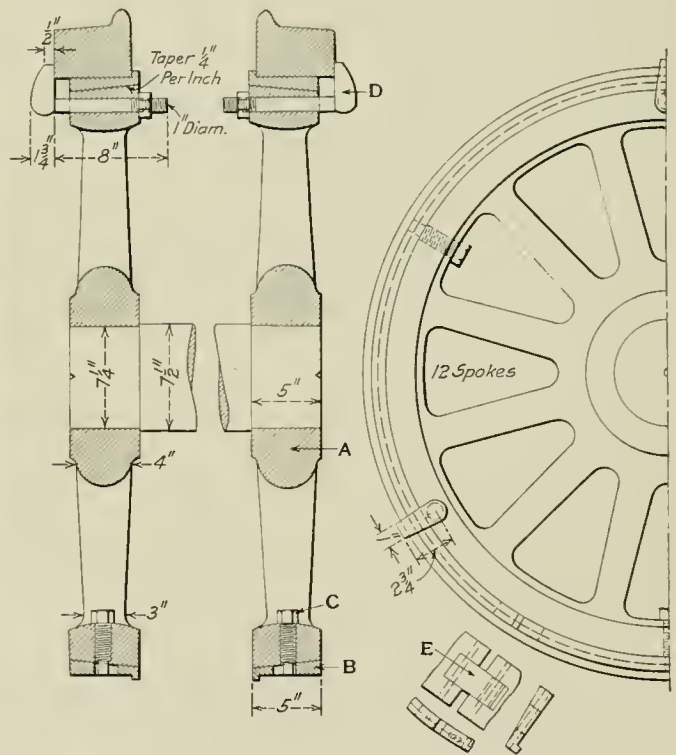

Expanding Mandrel for Mounting Tires in a Wheel Lathe

of tires of the same size which may be bored to slightly varying diameters, the expanding arbors shown in the drawing were designed. Two arbor centers *A* which are generally similar to driving wheel centers, but without counterbalances, are mounted on an axle which may be swung between the lathe centers. These arbors are turned tapering on the outside and to them are fitted the split bands *B*, which are provided with shoulders on the inside to line up the tires. These are made in sets of different thicknesses to take different size tires. The screws *C* are threaded through the rim, their outer ends working in slots in the band, and serve to hold the band in place before the tire is mounted. The ends of the band are slotted to receive a block *E*, which is held in place by pins through the ends of the band. The pin hole in one end of the block is slotted, however, to provide for the necessary expansion of the band.

When the tire is in place it is clamped at three points by the

special bolts *D*. These force the tire against the shoulder on the band, which is in turn forced on the taper center, and as it expands it provides a uniform bearing against the tire throughout its circumference. When the tires have been turned they may be very easily removed from the arbors. After the clamp bolts have been loosened all that is necessary is to strike the tires on the inside with a sledge, when they will fall off.

### COMPARATIVE LOCOMOTIVE SHOP RATIOS

BY HENRY GARDNER

There are fairly well defined ratios of men and machines to the monthly output of locomotives in railway repair shops. Although the data upon which such ratios are based in any specific case are constantly changing and the ratios only approximately correct, they serve a very useful purpose as a guide when considering important changes in organization and equipment.

In the accompanying tables are presented in detail the ratios for representative locomotive shops located at various points in

upon the layout of the shop, without correspondingly effecting the output of the shop. However, it is conceded that the smaller the number of pits in relation to the output, consistent with conservative practice, the more efficient the shop. The grouping of engines on a limited number of pits decreases the working area and centralizes the efforts of the working forces resulting in less waste of time and more effective supervision. The ratio of men to the number of locomotives turned out per month is also open to criticism as a means of direct comparison since some large shops do very little repair work requiring an expenditure of less than \$500 per engine, leaving the lighter repairs for the engine houses and division terminal shops. In determining the ratios for the various departments it is also difficult to make proper allowances for differences in organization. For example, in one shop all lagging work is done by the carpenter shop force and in another this work is handled by the tender shop. The data in Table I, however, have been compensated for all such variations in organization and in each case are directly comparable in this regard.

Notwithstanding the many conditions effecting the compara-

TABLE I.—COMPARATIVE GENERAL SHOP RATIOS.

Dept.	Total No. of men aver. for one year				Men per working pit				Average No. of Men per loco. out per month†				Power machines per working pit			Power machines per loco. out per mo.			
	A	B	C	E	D	A	B	C	E	D	A	B	C	E	A	B	C	E	
Erecting.....	263	288	141	139	99	11.0	7.0	3.0	3.4	6.6	3.6	4.0	2.6	2.0	3.3	.46	.34	.04	.29
Machine*.....	412	256	252	172	159	17.1	6.2	5.7	4.2	10.6	5.4	3.6	4.7	2.5	5.3	11.4	4.2	2.8	3.3
Smith.....	142	74†	138	56†	78	6.0	1.8	2.9	1.4	5.2	1.9	1.1	2.5	.80	2.6	2.3	.66	.73	.51
Boiler.....	360	252	186	198	87	15.0	6.1	3.9	4.8	5.8	4.7	3.5	3.5	2.8	2.9	1.4	1.1	.73	.85
Tender.....	88	64	55	40	26	3.7	1.5	1.1	.98	1.7	1.2	.89	1.0	.57	.87	.33	.29	.15	.46
Tin and pipe.....	114	66	40	29	29	4.7	1.6	.85	.71	1.9	1.5	.92	.74	.42	.97	.13	.07	.02	...
Paint.....	16	27	15	14	6	.67	.66	.31	.34	.40	.21	.24	.28	.20	.20	...	...	...	...
Labor gang.....	45	48	84	26	10	1.9	1.2	1.8	.64	.66	.60	.68	1.6	.37	.34	...	...	...	...
Totals.....	1440	1075	911	674	494	60.2	26.2	19.4	16.5	33.0	19.1	14.9	16.8	9.6	16.5	16.0	6.7	4.5	5.4

\*Includes axle shop, millwright shop and air brake department.  
†No power work done in these shops.  
‡Average taken for one year period.

the East and Middle West. These shops are designated as *A*, *B*, *C*, *D* and *E*. Shop *A* is of the longitudinal type, shops *B*, *C* and *E* of the transverse type, and shop *D* a roundhouse. Shops *A* and *D* are located on the same road, as are also *B* and *E*. Shops *A*, *B* and *E* are in the East, while *C* and *D* are in the Middle West.

Referring to Table I, the number of men per working pit in each department of the shop are shown, as well as the number

of power machines per working pit and the average number of locomotives turned out per month. In view of the variability of the ratios, they may still be of considerable value in a study of shop organization. The following instances may serve to indicate the use to which they may be put. After a careful examination of the plant, the writer was reasonably sure that shop *A* was over-burdened with machines, mostly old-fashioned and obsolete. This opinion is confirmed by reference to the table, where the number of power machines per working pit is shown to be 11.4 for shop *A* as compared with 4.2, the next

TABLE II.—COMPARATIVE SPECIAL MACHINE RATIOS.

	MACHINE SHOP.																											
	Lathes				Planers				Drilling Mach's				Shapers				Slotters				Bor'g Mills				Milling Mach's			
	A	B	C	E	A	B	C	E	A	B	C	E	A	B	C	E	A	B	C	E	A	B	C	E				
Machines per working pit...	5.4	1.3	.98	1.2	.92	.27	.32	.24	1.7	.49	.47	.32	.58	.22	.15	.19	.33	.12	.08	.13	1.0	.37	.28	.50	.54	.17	.13	.2
Machines per loco. out per month.....	1.7	.66	.85	.67	.29	.14	.28	.14	.53	.25	.41	.15	.18	.11	.13	.09	.11	.06	.07	.05	.32	.19	.24	.20	.17	.09	.11	.10

	SMITH SHOP.																							
	Shears				Punch and Shears				Power Hammers				Forging Machines				Bull Dozers							
	A	B	C	E	A	B	C	E	A	B	C	E	A	B	C	E	A	B	C	E	A	B	C	E
Machines per working pit.....	.13	.05	.06	.07	.21	.05	.04	.06	.58	.22	.21	.12	.25	.07	.13	.14	.16	.02	.04	.06	.05	.01	.03	.03
Machines per loco. out per month....	.04	.03	.05	.04	.06	.03	.03	.01	.18	.11	.18	.07	.08	.04	.11	.05	...	...	...	...	...	...	...	...

	BOILER SHOP.																							
	Shears				Punch and Shears				Punches				Drilling Machines				Bending Rolls							
	A	B	C	E	A	B	C	E	A	B	C	E	A	B	C	E	A	B	C	E	A	B	C	E
Machines per working pit.....	.04	.07	.08	.05	.04	.02	.02	.02	.13	.10	.13	.06	.08	.10	.15	.12	.08	.07	.04	.07	.02	.04	.03	.04
Machines per loco. out per month....	.01	.04	.07	.03	.01	.01	.02	.01	.04	.05	.11	.03	.02	.05	.13	.07	...	...	...	...	...	...	...	...

Note—Machine data for shop *D* is not available.

of men per locomotive repaired per month. The number of working pits and the average number of locomotives turned out each month are as follows:

Shop.	Number of pits.	Average number of locomotives out per month.
A.....	24	76
B.....	41	72
C.....	47	54
D.....	15	30
E.....	41	70

It is, of course, true that the ratios of men and machines to the number of working pits are not of great value for comparative purposes since the divisor may be large or small, depending

upon the layout of the shop, without correspondingly effecting the output of the shop. However, it is conceded that the smaller the number of pits in relation to the output, consistent with conservative practice, the more efficient the shop. The grouping of engines on a limited number of pits decreases the working area and centralizes the efforts of the working forces resulting in less waste of time and more effective supervision. The ratio of men to the number of locomotives turned out per month is also open to criticism as a means of direct comparison since some large shops do very little repair work requiring an expenditure of less than \$500 per engine, leaving the lighter repairs for the engine houses and division terminal shops. In determining the ratios for the various departments it is also difficult to make proper allowances for differences in organization. For example, in one shop all lagging work is done by the carpenter shop force and in another this work is handled by the tender shop. The data in Table I, however, have been compensated for all such variations in organization and in each case are directly comparable in this regard.



equally to this table, which may often be found useful as a check on conclusions reached after an examination of any particular shop.

On the whole the figures given in the tables show a considerable variation both in number of men and machines which would indicate that there is room for improvement in some of our railroad shop organizations and equipment. This fact is plainly shown by comparing the total number of men, number of pits and number of locomotives despatched in shops *B* and *E*, these are as follows

Shop B—1,075 men, 41 pits, 72 engines despatched per month.  
 Shop E— 674 men, 41 pits, 70 engines despatched per month.

Here we have shop *E* delivering but two less locomotives than shop *B* but with 401 less men. This wide variation may be partly accounted for by a knowledge of the class of work and power handled at these two shops, but it undoubtedly points to a much stronger organization and greater efficiency in the latter shop. It is, of course, understood that the total number of men shown in Table I does not represent all of the men employed, but simply the total number of men in the departments considered.

### BRACKET FOR SAFETY VALVE TEST GAGE

BY C. S. TAYLOR

General Foreman, Atlantic Coast Line, Wilmington, N. C.

Rule No. 35 of the Interstate Commerce Commission's rules for the inspection and testing of locomotive boilers, requires the use of two steam gages in setting safety valves. The regular locomotive steam gage answers for one, but it is necessary to have another gage in full view of the operator setting the pops. In many cases this requirement has been met by attaching the second gage to a small wooden bracket placed on top of the cab. On modern locomotives, however, the safety valves are usually located at some distance from the cab, and in

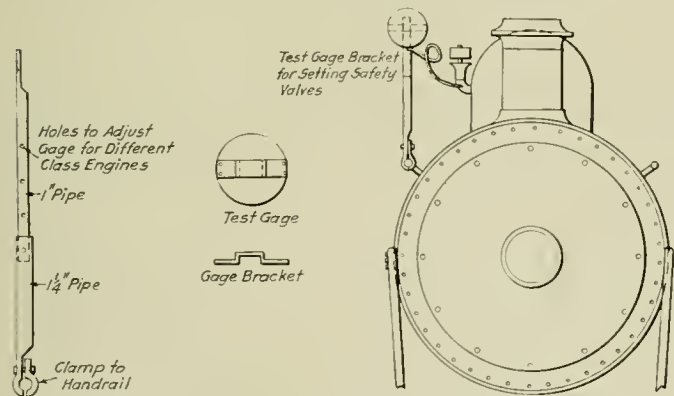

A Convenient Bracket for the Safety Valve Test Gage

roundhouses, where the light is poor, it is difficult for the operator to see a gage so located.

The sketch shows a bracket which may be clamped to the hand rail at any point convenient for the operator, on which the test gage may be placed. It consists of a piece of 1¼-in. pipe within which is telescoped a piece of 1-in. pipe. The lower end of the 1¼-in. pipe is flattened and welded to a simple pipe clamp and upper end of the 1-in. pipe is flattened to fit a socket attached to the back of the gage. Holes drilled through the telescoping portions of the two pipes permit of any desired vertical adjustment of the gage to suit boilers of different sizes. All of our locomotives are provided with an outlet closed with a small globe valve, either in the whistle elbow or in the dome cap, to which the gage syphon pipe is attached when setting the pops.

This stand can be made in any roundhouse, from scrap pipe at a very small cost; it is of light weight and very easily handled. Either copper steam gage pipe or flexible tubing may be used for the steam gage connection.

### PISTON VALVE PACKING\*

BY F. W. SCHULTZ

District Foreman, Union Pacific, Grand Island, Neb.

My experience with piston valves dates from 1898, at which time they were just coming into use on the western roads. The L-ring was used mostly at first. In about two years the rectangular ring came into use soon to disappear. The T-ring was then tried and its life in my experience was of short duration. In a short while the Z-ring was tried and has been improved until it has finally developed into almost the size and shape of a rectangular ring with the exception of a slight offset, one side being offset a little more than the other. This, from my experience, is the best ring. The L-ring is too light and is used mostly on solid valves. To apply this ring it must be sprung over the end of the valve. This so distorts it that it will not go back to its former shape. The pressure of the steam on the L-ring on the admission side of the valve usually sets the ring too tight to the valve bushing, excessively wearing both the ring and the valve bushing. This soon causes the rings to have an excessive opening which permits the carbon from the oil to be deposited under rings and thus causing a shoulder to be worn in the ring grooves. In the event one or more of these rings get a water jam from the cylinder they stick, usually being closed, which causes a blow and makes an engine lame.

The L-ring on the exhaust side of the valve is likewise too light. Its function is to hold the steam in the cylinder during expansion. The pressure of the steam in the cylinder acting on the outside diameter of this ring will close it and at the same time blow by. This is proven conclusively by the fact that, both rings having equal length of service, the admission rings are worn bright, while the exhaust rings still show tool marks. The moment of exhaust is the only time the exhaust ring will be "set out" against the valve bushing similar to the admission ring. Another objection to the L-ring is that it can not be fitted nor applied to a solid valve as well as the Z-ring can be applied to a built-up valve. The L-ring is practically as expensive to make as the Z-ring and more liable to be broken when applied, especially if there are flaws in the metal, as it is of smaller cross section. This item should not be forgotten when considering the expense of manufacturing the L-ring. The foregoing objections to the L-ring are not true of the Z-ring.

The Z-ring should be used in a built-up valve and properly doweled at the bottom, using as small a dowel as practical. The ring should be carefully faced and fitted in the valve grooves and be made as nearly steam tight as possible. The follower head should clamp the bull ring and not the valve rings. The Z-ring should be from ¾ in. high by ½ in. wide to ⅞ in. high by ¾ in. wide and possibly 1 in. wide, and bored on the inside just large enough so as not to carry the valve but if anything to compel the valve to carry the ring. Some shops have practiced grinding in valve rings. The ring should be given its required snap, then pulled together and clamped in a special chuck and turned to the exact diameter of the valve bushing. By following this practice the ring will have a perfect bearing and also the necessary snap. A heavy ring carried by the valve needs only about 1/16 in. snap, as it will not wear on account of having excessive snap and it cannot be so easily distorted by the pressure of the steam.

The Z-ring should have a proper offset to prevent its getting out of the groove and catching in the steam ports when broken. A Z-ring properly fitted and shouldered has been found broken and still in place with no blow being detected, whereas other types of rings invariably get out of the groove, causing a bad blow and engine failures. A rectangular ring is as good as a Z-ring with one exception, there is no way to secure it to the valve in event of breakage.

Many mechanics and foremen file the rings open, figuring

\*Entered in the Piston Valve Packing Ring Competition which closed October 1, 1915.

that the expansion due to the heat of the steam will close them. This is mostly guess work, as I doubt if any have ever found out what expansion takes place. A packing ring of any description filed open is certainly not steam tight. The length of time a new ring would be tight from expansion would be very short as the cylinder walls get hot very quickly. As to the cost of machining, etc., the following are very reasonable figures considering what has to be done. A 15-in. ring of the Z-type can be machined out of ordinary grey iron for 45 cents, labor and material. This depends, of course, upon the facilities, the price of labor and the quality and kind of material used. Some bronze rings of the same type are in use on superheater engines and can be manufactured for \$1 each, total cost, including the store expense.

The one important feature of economy is the fuel saving. As above mentioned, an exhaust ring the least bit open is closed by the pressure of the steam, after the steam is in the cylinder, on account of the greatest area being exposed to the steam. The old idea of doweling the rings on the bottom was to prevent blowing, however, the feature of the open exhaust ring closing has been overlooked. Each ring opened  $\frac{1}{8}$  in. is equal to one ring being open eight times  $\frac{1}{8}$  in., or one inch, as there are eight rings in two valves. Certainly no one would say a ring open one inch would not blow, especially with 200 lb. of steam. The ring with such a hole in it, possibly blowing continually for six to eight hours, or longer, would eat a big hole in the coal pile.

I have found that 95 per cent of engineers do not favor the wide throttle—Why? They say they lose water; they are correct, but it's the fault of poor packing, or poorly fitted packing. Give an engineer an engine with good, well fitted packing of the Z-type and he will readily see that a wide throttle and a short cut-off does the business. I have found in a great many cases that the cheapness of machining or the total cost of valve rings has been a matter of study and pride instead of the after effects of a cheap job and material on the coal pile. Eight well fitted 15-in. Z-rings applied ready for service would cost \$10, including labor and material. When poor rings are used the valves will blow. Any perceptible blow will waste easily a ton of coal on a freight train in 100 miles, which, the coal costing \$3 per ton put on an engine, would be a waste of about \$90 for fuel alone for one month. Therefore, would it not pay to keep the packing tight?

### HELP THE APPRENTICES TO HELP THEMSELVES\*

BY MILLARD F. COX

Assistant Superintendent Machinery, Louisville & Nashville, Louisville, Ky.

Men have imitated other men, more or less, in every generation. Boys have done the same thing, and the brightest apprentice soon, almost unconsciously, selects his ideal and proceeds to follow him, or surpass him, according to his ambitions. How necessary is it then to have men in all leading positions whom the boys can look up to and imitate. In my own case, I have in mind one man who could handle a file so skillfully that I found myself practicing at every opportunity to hold my file as he did, and shove it just as expertly. And a certain fellow who could chip faster and smoother than any of the others, I was constantly trying to imitate.

It is important to have attractive courses mapped out, a program of interest to the beginner as well as to the apprentice supervisor. It is also important to select boys who have some real ambition, entirely beyond the sordid desire to reach the journeyman's wage. Few boys realize how little value their services really are to their employers for the first six or eight months. They think more of putting in the time, pay day, and dodging the boss, than of acquiring knowledge. It is an up-hill

job to take green boys into a shop and educate them to be useful. The modern method is to have a careful, well trained mechanic to supervise and instruct them, giving his entire personal attention to this branch of the service. To him the boys should have ready access, and he should be competent to answer their inquiries and set them right on *all everyday questions*. If the apprentice supervisor is a mere figurehead the shop will be much better off without him, and you may be sure the boys will soon ignore him.

The well-known modern apprenticeship courses, now so popular in many of our large railroad shops, have done much in the right direction. The mechanical journals have also aided in many ways. The heads of our large railroad systems have encouraged the leaders in these movements to some extent. All combined, however, will never do for the boy what he must do for himself, and so I say to the young men of every branch, and in every shop, we are perfectly willing to *help you help yourself*, and it depends on you more than it does on us. Show a willingness by being in your place regularly; don't be too well satisfied with yourself; work from under the task, no matter how arduous it may seem at first, it will come lighter as the chips fly. Give your employer good measure, heaped up and running over of your time; finish the job even if the whistle has blown several minutes ago. What is a few moments compared to the satisfaction of a "Well done, my boy," from your boss? It's worth the price and more. It is the nearest equivalent to a raise of pay.

I am willing to help any boy in any way that I can that is willing to help himself some. No others need apply. This has been my attitude towards the apprentice for many years, for whom I have a very friendly feeling.

### SUPPORTING SHAFTING IN CONCRETE BUILDINGS

BY C. C. LEECH

The securing of supporting beams for line and counter shafting often presents a serious problem in buildings of concrete construction. Even where it is permissible, the drilling of holes through the concrete and the imbedded steel requires considerable labor and expansion bolts require a very accurate layout.

The writer was called upon to solve a problem of this char-

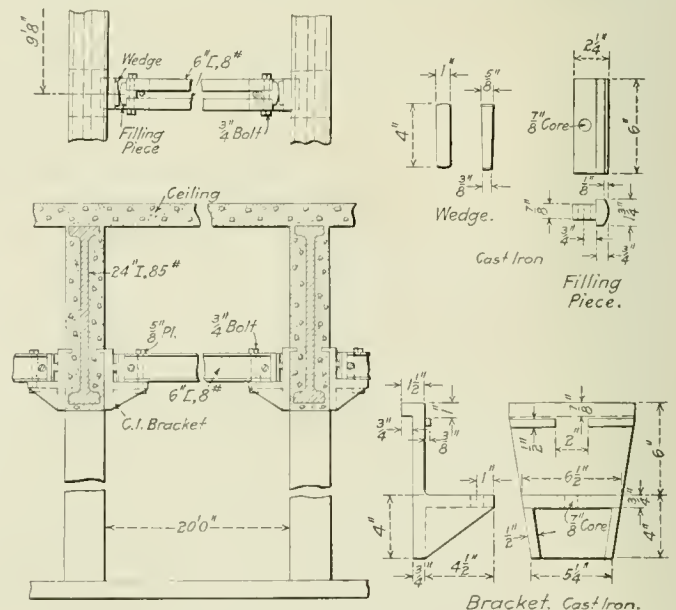

Details of Shaft Supporting Beams for a Concrete Building

acter where some thirty machines were to be installed, none of them motor-driven and all requiring the usual overhead countershafts. In the illustration is a sectional elevation of the building showing a portion of ceiling and floor and the imbedded

\*Entered in the competition on "How Can I Help the Apprentice?" which closed September 1, 1915.

I-beam construction of the frame. The distance from pillar to pillar across each bay is 20 ft., and to span this space 6-in. 8-lb. steel channels were used, bolted together in pairs.

The details of the arrangement finally adopted, by which the channels were attached to the concrete, are clearly shown. Recesses were cut in the concrete at the proper height to receive the 1-in. by 3/4-in. flanges on the top of the cast iron brackets. The channels, assembled with special cast iron filling pieces, or shoes, between the ends were then placed on the brackets and secured by 3/4-in. bolts passing through a short 5/8-in. plate and between the channels. The entire assembly was then securely locked in position by driving wedges between the backs of the brackets and the channel shoes.

After the installation had been completed and the line shafting tested a variation of but 1/8 in. was detected in a length of 125 ft.

### REPORT OF THE CHIEF INSPECTOR OF LOCOMOTIVE BOILERS

The following is taken from the fourth annual report of Chief Inspector of Locomotive Boilers McManamy to the Interstate Commerce Commission:

The work of the division of locomotive boiler inspection during the year has been substantially the same in character as the work of that division in previous years. The tables show in concrete form the number of locomotives inspected, the number and percentage found defective and the number ordered

	1915	1914	1913	1912
Number of locomotives inspected.....	73,443	92,716	90,346	74,234
Number found defective.....	32,666	49,137	54,522	48,768
Percentage found defective.....	44.4	52.9	60.3	65.7
Number ordered out of service.....	2,027	3,365	4,676	3,377

Locomotives Inspected, Number Found Defective and Number Ordered Out of Service

out of service on account of not meeting the requirements of the law during each of the four years the law has been in force. They also show the total number of accidents due to failure from any cause of locomotive boilers or their appurtenances and the number of persons killed or injured thereby,

	1915	1914	1913	1912
Number of accidents.....	424	555	820	856
Decrease from previous year.....	per cent. 23.6	32.3	4.2	
Decrease from 1912.....	50.5	23	36	91
Number killed.....	13	23	36	91
Decrease from previous year.....	per cent. 43.5	36.1	60.4	
Decrease from 1912.....	85.7	64	91	1,005
Number injured.....	467	614	911	1,005
Decrease from previous year.....	per cent. 24	32.6	9.3	
Decrease from 1912.....	53.5			

Number of Accidents and Number Killed or Injured

with the percentage of decrease each year since the law became effective; also the total decrease during that period. The data contained therein reflect the work performed and the results accomplished and further explanation or comment need not be made.

One of the tables shows the total number of persons killed and injured by failure of locomotive boilers or their appurtenances during the past four years, classified in accordance with their occupations.

All accidents reported have been carefully investigated, the cause determined, when possible, and the information thus obtained given to the carriers; and this has been an important factor in reducing the number of accidents.

Prompt reports of accidents materially assist in the work of investigation and reduce the delay to equipment, and as carriers now fully understand the requirements in this respect such reports, with rare exceptions, are properly made.

While the total number of accidents has greatly decreased, two particular types show an increase over the previous year.

These are accidents due to defective blowoff cocks and to injector steam pipe failures.

During the year there were 20 accidents due to defective condition of blowoff cocks or their operating mechanism, resulting in 1 killed and 19 injured. The fact that every one of these accidents was due to defects in the blowoff cock, or in

	Year ended June 30—							
	1915		1914		1913		1912	
	Killed.	Injured.	Killed.	Injured.	Killed.	Injured.	Killed.	Injured.
Members of train crews:								
Engineers.....	5	150	8	187	12	268	22	310
Firemen.....	7	207	8	290	12	478	19	491
Brakemen.....	1	40	1	46	4	79	8	79
Conductors.....	1	4	1	6	2	7	4	16
Switchmen.....	4	4	1	1	1	2	1	7
Roundhouse and shop employees:								
Boiler makers.....	5	1	18	10	2	2	3	3
Machinists.....	10	2	5	11	7	1	11	11
Foremen.....	2	1	6	4	1	1	2	6
Inspectors.....	3	1	3	3	3	1	2	6
Watchmen.....	1	1	7	8	1	1	1	5
Boiler washers.....	9	6	9	1	1	1	1	5
Hostlers.....	6	9	1	6				5
Other roundhouse and shop employees.....	2	1	17	1	24	14	62	62
Other employees.....	2	10	10	1	3	3	3	3
Nonemployees.....	1	1	1	2	3	6	2	2
Total.....	13	467	23	614	30	911	91	1,005

Total Number of Persons Killed and Injured, Classified by Occupations

the piping or operating mechanism, which could have been discovered by reasonable inspection, clearly indicates that these appurtenances are not receiving the same careful inspection and attention that other appurtenances are; therefore, the remedy is obvious.

Twenty-eight accidents due to failure of injector steam pipes, resulting in one killed and 30 injured, occurred during the year. These failures can be divided into two general classes, viz., failure of union nut and failure of brazing sleeve or collar, both of which are in many instances contributed to by failure to properly brace the injector.

Failure of union nut is usually due to thread stripping, nut too large, or nut broken, which in practically every instance was caused by the use of improper tools, such as hammer and chisel, or set, in tightening the nut; and our investigations have shown that the use of such tools is not confined to the engine-men on the road where proper tools are not available, but can be said to be almost a general practice of repairmen at terminals. While the failure does not always occur at the time the improper tools are used, it results in stretching or otherwise damaging the nut, ultimately resulting in failure which frequently causes injury.

Failure at brazing sleeve or collar is usually due to poor brazing, allowing the pipe to pull out of the sleeve, or failure of sleeve due to the fact that the spelter did not flow between the sleeve and pipe, resulting in the sleeve being brazed to the pipe only at its extreme end; therefore, the strain of the load and vibration, which should have been borne by the copper pipe, is thrown on the brass sleeve, which is not designed nor intended to carry it.

Investigation of all such accidents which have occurred during a period of more than four years has convinced us that failure of brazing or brazing sleeves can be practically eliminated by the adoption of what has been termed a "mechanical joint," which is made by extending the copper pipe through the sleeve, expanding it, and beading or flanging it over so that it will be firmly held in the union. This not only throws the load on the pipe, which is designed to carry it, but also makes it possible to determine by inspection before the pipes are applied whether or not the work has been properly done, which is not possible with the brazed joint.

We have been persistently recommending this form of joint, and as it is being adopted by many carriers and manufacturers as standard, we have refrained from recommending a rule requiring its use; but unless a reduction in accidents from failure of the steam pipes at the brazing sleeve can otherwise be brought

about, some action in this direction will become necessary.

The number of applications for an extension of time for removal of flues, as provided in rule 10, has increased over the previous year, and this has materially added to the work of this division, as such extensions are granted only after a special inspection of the locomotive has been made. During the year 1,099 applications for extension of time for removal of flues were filed by 284 carriers; of this number 638, or 58 per cent, were granted; 461, or 42 per cent, were refused or granted only after defects disclosed by our inspection had been properly repaired.

The rule referred to requires all flues to be removed at least once every three years and a thorough examination made of the entire interior of the boiler; that after flues are taken out the inside of the boiler must have the scale removed and be thoroughly cleaned. The rule also provides that this period

3. Date of previous removal of flues.
4. Mileage made since flues were removed and interior of boiler cleaned and inspected.
5. Period of time for which the extension is desired.
6. Approximate date when it will be convenient to have the locomotive held and dome cap and throttle standpipe removed to permit an interior inspection by a government inspector; also at what point locomotive will be held for this inspection.

It is to be presumed that carriers desire to properly maintain their locomotives; therefore, an application for an extension of time for removal of flues from a locomotive, which we find on examination to be defective, indicates that the railroad company's inspectors have not discovered the defective conditions.

In some instances it is evident that the application for extension of time has been filed without a proper attempt on the part of the carrier to determine whether the condition of the boiler would justify the application, as Federal inspectors find defects that could scarcely be overlooked if a reasonable inspection were made prior to filing the application, thus making it apparent that they are depending on us to do this work for them. When the conditions found indicate this practice exists, and that careful inspection is not being made by the carriers prior to filing application for extension of time, so they may know their request is a proper one, it becomes necessary for our inspectors to exercise extreme care in making their investigation, and to require the removal of all parts necessary to assure themselves whether or not the request for extension of time may properly be granted.

Alteration reports which are being filed, showing reinforcement of boilers which have a factor of safety below the standard fixed by the order of the Commission, dated June 9, 1914, indicate that diligent efforts are being made by the carriers to meet the requirements of that order, and with a few exceptions very satisfactory progress is being made. A standard alteration report, Form 19, containing carefully prepared instructions for filing such reports in accordance with rule 54, was issued on March 29, 1915. The use of this form in accordance with the instructions will simplify the reporting of alterations to boilers and enable the carriers to avoid considerable unnecessary work which some of them have been doing.

The act of March 4, 1915, amending the locomotive boiler inspection law by extending its provisions to include the entire locomotive and tender and all their parts has presented additional and important problems and will materially increase the work of this division. The preparation of rules fixing minimum limits for all parts of locomotives and tenders, so that the requirements might be definite, has been diligently pursued and is progressing as rapidly as accuracy will permit.

Very satisfactory progress is being made in arranging the work of the division so that the additional duties imposed by the law may be properly performed. This will probably make it necessary for our inspectors to follow more closely the requirements of Section 6 of the law, which provides that their "first duty shall be to see that the carriers make inspections in accordance with the rules and regulations established or approved by the Interstate Commerce Commission, and that carriers repair the defects which such inspections disclose," before the locomotives are again put in service, and may result in eliminating reports to railroad officials of minor defects discovered by federal inspectors, which, for the benefit of the carriers, have been directed to their attention; therefore, it will be necessary for each railroad company's inspectors to give more careful attention to such matters, as no change will be made in the method of handling violations of the law or the rules.

No formal appeal from the decision of inspectors, as provided in Section 6 of the law, has been filed during the year. In one instance, an appeal was filed from the findings of inspectors in an accident investigation. Reinvestigation by an assistant chief inspector, assisted by inspectors from other districts, not only sustained the original report but disclosed additional evidence in support thereof.

Nature of failure or defect.	Year ended June 30—											
	1915			1914			1913			1912		
	Accidents.	Killed.	Injured.	Accidents.	Killed.	Injured.	Accidents.	Killed.	Injured.	Accidents.	Killed.	Injured.
Arch-tube failures.....	7	9	12	19	20	3	27	18	23	11	11	23
Ash-pan blower defective.....	11	11	5	5	14	1	14	3	3	3	3	3
Blowers defective.....	5	5	11	11	13	13	11	11	11	11	11	11
Blow-off cocks defective.....	20	1	19	15	1	15	16	15	23	23	23	23
Boiler checks defective.....	9	10	11	11	11	11	12	11	11	11	11	11
Boiler explosions:												
A. Shell explosions.....			1	1				3	27	41		
B. Crown-sheet failures due to low water where no contributory causes were found.....	14	7	20	36	13	59	41	23	67	69	35	129
C. Crown-sheet failures due to low water where contributory causes or defects were found.....	9	1	14	12	3	18	28	6	50	23	15	38
D. Fire-box failures due to defective staybolts, crown stays, or sheets.....	1	2		4	1	7	5		8	1	1	1
E. Fire-box failures due to water forming.....	1		1	1		2	1	2		1	3	
Cross stays defective.....												
Crown stays defective.....												
Dome caps defective.....	3		3									2
Draft appliances defective.....	2			1		1	4		4	3		4
Exhaust nozzle breaking.....												
Fire doors defective.....	5		6	3		3						
Flue failures.....	41	52	51	56	54	1	63	56	1	62	8	8
Flue-pipe failures.....	2	2										4
Flue ports defective.....						4						4
Flue sheets defective.....						1						2
Gauge cocks defective.....	3		3			3						4
Grates defective.....				1		1						1
Handhole plates defective.....												
Injectors and connections defective (not including injector steam pipes).....	29	31	33	33	28		28	47	48	48		48
Injector steam-pipe failures.....	28	1	30	15	18	36		47	31	38		38
Lubricator defective.....	8		14	14	11		12	11	12	12		12
Lubricator glasses bursting.....	13	14	20	20	45		45	49	49	49		49
Lubricator piping defective.....	2	2	2	2	4		4		4			4
Mud-pan failures.....	1	4	1	2	2		2		2			2
Mud ring defective.....												
Patch bolts defective.....	1	1										1
Plugs (arch-tube) defective.....	1	2		4	5		5		6	1		4
Plugs in fire-box sheets defective.....	1	1	6	7	1		6	1	6	1		1
Plugs (fusible) defective.....			2		1		1		1			1
Plugs in steam chest defective.....					1		1		1			1
Plugs (washout) defective.....	15	18	17	1	17		23	11	2	14		14
Rivets defective.....	1	2	4	1	9		9		9			9
Safety valves defective.....	2	1	1	1	1		1		1			1
Squirt-hose failures.....	99	100	139	140	266		267	243	245	245		245
Stay bolts defective.....	3	5	5	5	5		5	9	9	11		11
Steam-hose defective.....	1	1	1	1	1		1	1	1	1		1
Steam piping defective.....	4	4	14	16	5		16	14	2	11		11
Studs defective.....	16	1	17	18	21		21	14	1	16		16
Superheater-tube failures.....	1	3			1		3		3			3
Tank hose defective.....												
Throttle glands defective.....												
Throttle leaking.....	1	1	1	1								
Valves defective (not including safety valves).....	8	8	3	3	0		6	5	5	5		5
Water-bar failures.....	1	1			1		1		1			1
Water glass bursting.....	48	48	60	60	128		128	163	1	168		168
Water-glass fittings defective.....	3	3	10	10	7		7	8	8	8		8
Miscellaneous.....	3	3	5					1	1	1		1
Total.....	424	13	467	555	23	614	820	36	911	856	91	1,005

Accidents and Casualties from Failures of Locomotive Boilers and Their Appurtenances.

may be extended upon application if an investigation shows conditions to warrant it. Removal of flues once in three years is required primarily to allow a complete interior inspection, as provided by Rule 11, and the making of necessary repairs, and not, as some evidently believe, on account of the condition of the flues.

To properly handle this work, carriers have been asked, when an extension is desired which their inspection indicates conditions warrant, to file applications with the chief inspector approximately 60 days before flues become due for removal, and in each case show:

1. Number of each locomotive for which the extension is desired.
2. Class of service in which the locomotive is engaged.

During the year 2,130 defective parts of locomotives not covered by the boiler inspection law, almost all of which were defective wheels, were reported to this division by inspectors and directed to the attention of the railroad officials with request that proper repairs be made before the locomotives were put in service. Such matters are now covered by the amended law, and will be handled in accordance therewith.

### HOW CAN I HELP THE APPRENTICE?\*

BY WALKER V. HINEMAN

Roundhouse Foreman, Chesapeake & Ohio, Russell, Ky.

The first and most important step in helping the apprentice is in proper selection. The old rule of boys placing their applications on file and receiving positions when their turn comes, or worse yet, the order of giving the old employees' sons the preference, should be suspended at once. Many a boy has undertaken to learn the machinist trade because his father was a machinist and at the time of entering his apprenticeship did not have the slightest idea of the seriousness of the undertaking. If asked what a machinist was he would say, "one who runs a machine."

The candidate should have a good common school education—the best a boy of sixteen can possibly obtain to-day. He cannot have too much. Better yet, the minimum age should be eighteen and the qualifications should be a diploma from a good high school. I do not think this asking too much, for it would certainly be a great help to the boy. He could not enter a technical school without these qualifications, so why not raise the standard for the apprenticeship applicant? It would make a great many more young mechanics eligible for positions as foremen.

Apprentices should be taken into the service on trial and this rule should be strictly adhered to. It is not fair to the boy to be allowed to spend four years of his life at a trade for which he is in no way fit, and at which he cannot perfect himself. And it is certainly an injustice to the company to allow him to complete his apprenticeship, call himself a journeyman, receive a union card and demand the scale of wages paid in his locality, when he should be "hiling back ends" in a dentist's office, or making pills in an apothecary's shop.

Much has been said concerning modern apprenticeship, or the instruction of apprentices in trade schools by railroads. Our railway is one of the leaders in this work, but at the small points and roundhouses these advantages cannot be had. In such cases it is up to the foreman in charge to help the apprentice. This can best be done by taking the apprentice when he first enters the service. Get acquainted with him, instruct him as to his duties and the obligations he is under to the company by binding himself for a four-year apprenticeship, and the obligations he is under to himself to make the best he can of himself while he is serving his apprenticeship. Impress upon his mind the opportunities open to good mechanics and the opportunities open to good apprentices that will try for them. Win his confidence.

Don't try to make him afraid of you and have him calling you the "old man," or some other disrespectful epithet when your back is turned. Give him the best possible chance to master the trade your shop affords. Have confidence in the apprentices and encourage them in their undertakings so they will exert their best efforts. Study their characters and dispositions and handle them accordingly. Spur them on. Put them up against emergencies to give them confidence in themselves.

**OIL FOR COMPRESSOR CYLINDERS.**—Oil for air-compressor cylinders should have a flashpoint of 550 to 600 deg. F., according to the air pressure and rapidity of compression; for steam cylinders operated with superheated steam upward of 600 deg., according to the amount of the superheat. Saturated steam will not disintegrate oil of 550-deg. flashpoint. For internal-combustion engine cylinders oil of as low flashpoint as will do the work should be used (about 450 deg.).—*Power.*

\* Entered in the competition on "How Can I Help the Apprentice?" which closed September 1, 1915.

### PORTABLE KEROSENE VAPORIZER

BY H. E. OPLINGER

General Foreman, Atlantic Coast Line, Brunswick, Ga.

By means of the device shown in the drawing kerosene has been very successfully used in heating tires and for other heating operations in the shop requiring a portable burner. The equipment is mounted on an old shop truck of the usual type, and consists of an old auxiliary air drum and a coke furnace for vaporizing the oil, both of which are securely attached to the truck frame.

The furnace is a box 12 in. by 12 in. by 12 in., made of 1/4-in. boiler plate, the bottom being perforated with 3/8-in. holes. A lift door is placed on one side, through which the fire may be removed when not in use. Within the furnace is a cast-iron

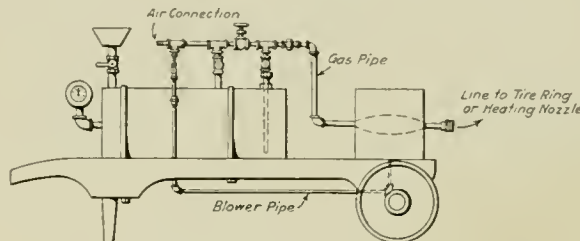

Vaporizer for Burning Kerosene

gas generator 12 in. long and 2 1/2 in. in diameter at either end, expanding in section toward the center of the furnace at which point it has a diameter of 4 in. Into the ends are tapped 1/2-in. pipes, one of which is connected to the oil tank and the other to the pipe line leading to the tire heating ring, or other type of burner, as the case may be. A 3/8-in. blower pipe leads from the air line to the bottom of the furnace.

When the device is to be placed in operation a coke fire is built in the furnace, and is kept burning throughout the period of operation. This raises the gas generator to a red heat, and keeps it in that condition, the kerosene thus being completely vaporized before passing to the burner; the result is a steady, blue flame. The device may be operated by any handy man with perfect safety, and the cost of operation is very low.

### STRAIGHTENING TRIPLE VALVE PISTONS

BY J. A. JESSON

It is the general practice to straighten in a lathe the stems of triple valve pistons which have been bent, a practice so expensive as to often be prohibitive. The drawing shows a device

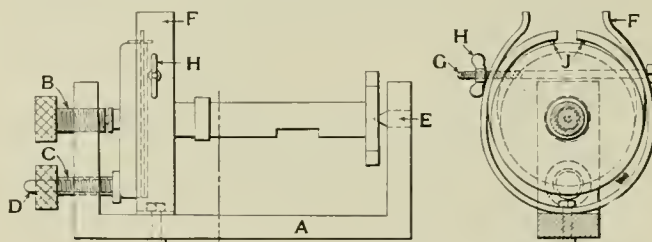

Device for Straightening Triple Valve Pistons

which has proven very successful in reducing the cost of this work, the operation of which is very simple.

The body of the device *A* is made from bar iron 1 1/4 in. square, the end being forged at right angles to the yoke and fitted with the centers *B* and *E*. The piston to be straightened is placed between the centers and secured by the adjustable center *B*. At *C* is shown a hollow screw threaded through the end of the body. Working freely in this screw is a brass pin *D* with a flat head on the inner end. When the piston is in place it is revolved and the screw *C* is adjusted until the end of the

pin *D* is brought in contact with the nearest point on the face of the piston. The straightening is effected by lightly striking the outer end of the pin, continuing to turn the piston and operate the screw *C* until the head of the pin touches the surface of the piston all around.

This device also serves to hold the piston while filing down the ends of the rings in fitting them to the cylinder. The piston is clamped tightly between the centers and the ends of the ring blocked up out of the groove by means of the wires *J*. After placing a file between the ends of the ring, the latter is closed by pressure from the spring clamp *F*, which is tightened by means of the bolt *G* and thumb nut *H*, thus pressing the ends against the file.

## QUICK ADJUSTMENT PLANER CLAMPS

BY ROBERT W. ROGERS

The type of clamp usually provided for holding down work on the planer table requires the use of blocking to adjust for the varying height of the work. This is unnecessary with the clamp which is shown in the drawing, as it is adjustable in itself.

The device consists of a hexagonal block to which is pinned

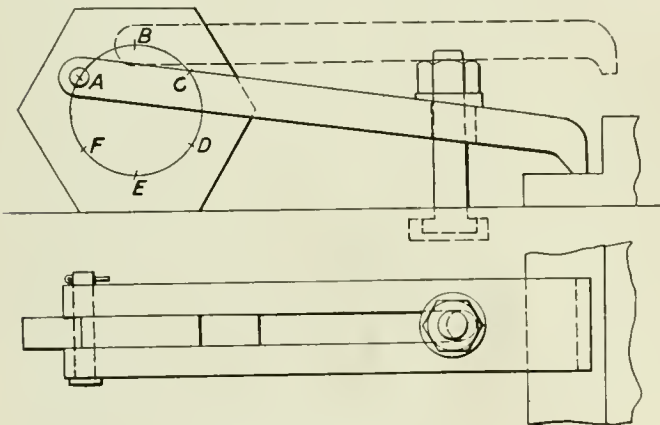

Adjustable Clamp for Planer Work

one end of the forked clamping arm. The point of attachment, shown at *A* in the illustration, is eccentric with the axis of the hexagon and by turning the latter this point may be brought into any of the other positions indicated. Any one of four different heights thus may quickly be obtained.

The principle may be extended, as for instance, by using an octagon block instead of the hexagon, which will increase the number of steps in the range of the adjustment. This clamp is a European device, which has proved of considerable value in planer work.

## SUGGESTIONS ON APPRENTICESHIP\*

BY AN OLD APPRENTICE

In the average railroad shop which has not progressed to the point of having an apprentice instructor the apprentice is such in name only. He is a wandering waif without a friend; there is no kind hand to guide him. If he amounts to anything it will be in spite of his environment, not because of it.

One apprentice course I have in mind looked fine on paper. After reading it over you would have rubbed your hands together with satisfaction and said, "surely here they are turning out good mechanics." What was really happening? One bright ambitious boy was kept for over two months cutting off flue thimbles, a job about which you could learn everything in one day.

Now the thing which was lacking in that shop was someone to

take an interest, some one to see that when the course called for three months lathe work the time was not all spent in cutting off flue thimbles, a job for some old man about ready to be retired. When this boy finally got desperate and raised an objection he was branded by the foreman as "impatient and a kicker."

In another shop the work was changed often enough, but when the man in charge made the prescribed changes he considered his duty ended. There was no one who took the time or trouble to suggest to or instruct the beginner. What happens we know only too well—Munsterberg has put it very aptly as follows: "The apprentice approaches the instruction in any chance way, and the beginner usually learns even the first steps with an attitude which is left to accident. An immense waste of energy and a quite anti-economic training in unfit movements is the necessary result."

In every shop there should be some one big hearted and wise enough to take up the cause of the apprentice. Make the matter personal. Why not *you*. Certainly it will do you no harm, and while it may take up a little of your time, you will have the feeling of having done something worth while.

Are you, Mr. Foreman, or Mr. Master Mechanic, deeply interested in the careers of the young "mechanics-to-be" for whom you are responsible? Are you interested to the point that you know them by name, have their confidence, and have at the end of their course a well defined idea of what class of work each one is best fitted? If you do not measure up to this standard your whole organization will ultimately suffer, and you are missing an opportunity to broaden your view point and sympathies, which is distinctly your own personal loss as well as the loss of the apprentices.

## SPECIAL TOOL HOLDER FOR BROKEN DRILLS

BY W. C. STEPHENSON

Assistant Machine Foreman, Atlantic Coast Line, Rocky Mont, N. C.

A special tool holder is in use at this point by means of which drills broken two or three inches from the cutting end, and all types of broken drill shanks may be used as cutting tools for turning, facing, threading or finishing operations. The essential features of the device are clearly shown in the drawing. The body of the holder is drilled as clearly shown in the longitudinal section, the opening at the end of the tool being

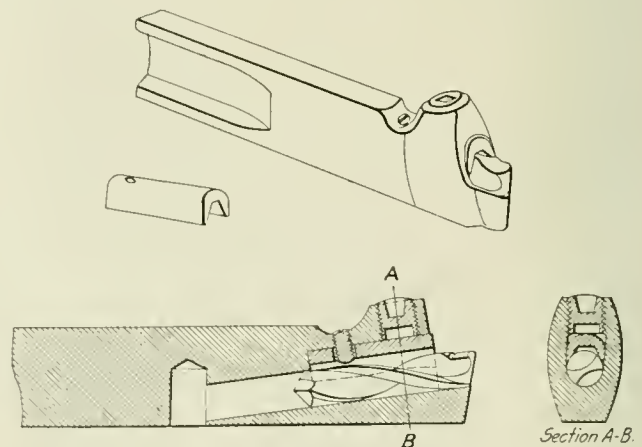

Holder Using Broken Drills for Cutting Tools

enlarged to receive an adjustable clamp block. The clamp has two divergent gripping surfaces, the angles of which cause the clamp to securely wedge the tool into position laterally, the clamp being tightened by means of the socket set-screw. The clamp block is retained in the holder by a small screw extending into a hole near its inner end. This screw is threaded in the holder but not in the block.

\* Entered in the competition on "How Can I Help the Apprentice?" which closed September 1, 1915.

# NEW DEVICES

## LARGE PNEUMATIC RIVETER

Two riveters, which are believed to be the largest pneumatic riveters ever constructed, have recently been built by the Hanna Engineering Works, Chicago. The machines have a reach of 21 ft. and are capable of exerting a pressure of 100 tons on the rivet dies at 100 lb. air pressure. The machines weigh 40 tons each, and an idea of the size and type of construction may be obtained from the accompanying photograph.

Until the development of the Hanna combined toggle and lever system for transmitting the pressure from the air cylinders

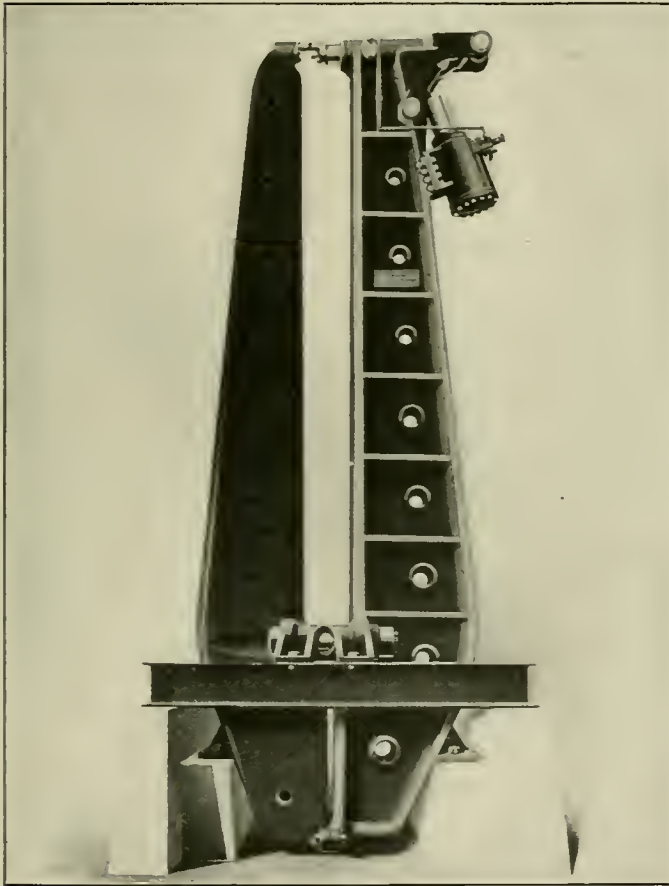

High Capacity Pneumatic Riveter

to the rivet dies, steam tight riveting for high pressure requirements was done almost wholly by hydro-pneumatic or hydraulic machines. The hydro-pneumatic principle has had a comparatively limited use on account of the difficulty in maintenance, due to the excessive pressure set up in the intensifying chamber. The straight hydraulic riveters have, therefore, received the widest application. The Hanna type pneumatic riveter is fitted with a toggle system designed to give a large opening of the dies, the pressure gradually increasing as the toggle movement closes until the desired maximum is reached. A simple lever movement then operates through the remainder of the stroke under approximately uniform maximum pressure, the movement of the die during this part of the stroke being great enough to remove all uncertainty as to the pressure applied to the rivet. When the machine is once adjusted for a certain length of rivet and thickness of plate, this movement is of sufficient extent so that no further adjustment for ordinary

variations in length of rivets, size of holes or thickness of plates need be made.

The riveter shown in the illustration is provided with a cylinder having a piston stroke of 22 in., with a die travel of 5¾ in. As in the smaller machines, the toggle action operates during the first half of the piston stroke with an approximate die travel of 4¾ in. At this point the maximum pressure is reached and the mechanism automatically changes to a simple lever action without a critical point in the pressure curve. The remaining 11 in. of piston travel effects the last one inch of die travel at uniform maximum pressure. By the use of a simple pressure regulating valve in the air supply line, the cylinder air pressure may be quickly changed to produce any desired pressure on the rivet dies within the rated tonnage of the machine.

## BIPOLAR OXYGEN AND HYDROGEN GENERATOR

An apparatus for the manufacture of oxygen and hydrogen by the electrolytic process has recently been brought out by the International Oxygen Company, New York. This is a bipolar device and is entirely different in construction and operation from the unit type generator built by the same company.

The bipolar generator consists of a series of metallic plates clamped together in a heavy frame, electrically insulated from

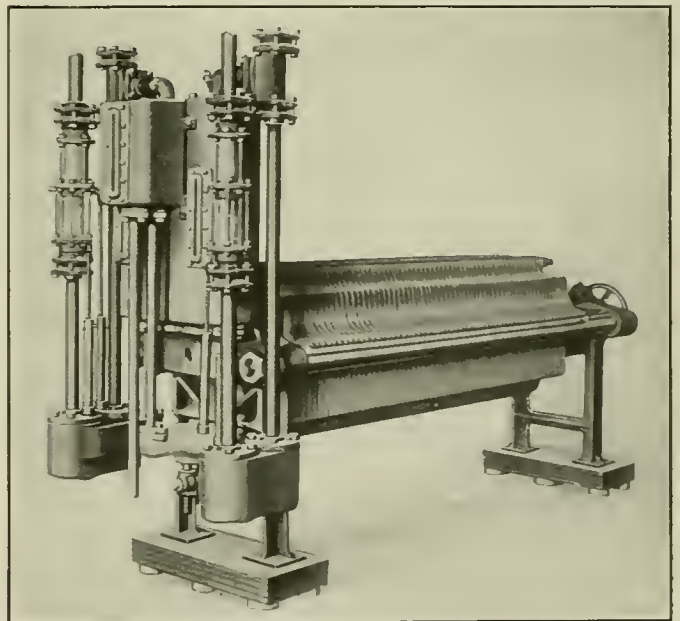

Bipolar Continuous Oxygen and Hydrogen Generator

one another, and separated by diaphragms of porous fabric. Each pair of these plates forms a closed cell, divided by the diaphragm. These cells are filled with the electrolyte—caustic potash or soda—which acts as a conductor, the plates acting as the electrodes. An electric current admitted at one end plate passes through the plates and the solution to the other end plate. In its passage it decomposes the water in the solution into the two gases, oxygen and hydrogen, which are released on opposite sides of each plate and emerge upward into the gas offtakes. The mingling of the oxygen and hydrogen in each cell or compartment is prevented by the diaphragm which, while

permitting the passage of the fluid, resists the passage of the gases. As the gases are released and withdrawn, the solution is automatically replenished from a supply tank. The operation is continuous so long as current and electrolyte are supplied.

In the smaller machines the electrodes are carried on two steel rods supported on two heavy end-pieces or pedestals of cast iron. In the larger generator the side rods are replaced by steel bars. The construction is one of extreme rigidity, absolutely proof against any distortion and consequent disarrangement of electrodes, with resultant leakage. Only the two end supports are necessary, no middle support being used.

The electrodes are of a special patented design, the anode side being heavily nicked, while the cathode side is of commercially pure iron. The surfaces of the electrodes are corrugated, and the corrugations are broken by a large number of depressions, to facilitate the flow of electrolyte into the cell and the release of the gases from it. At top and bottom of each electrode are two circular openings communicating by cored channels with opposite sides of the plate. Those at the bottom are for the water intake, and those at the top are for the gas outlet. It will be seen that each half of each cell has its own independent water intake and gas outlet, so that there can be no possibility of the two gases mingling through these channels.

The diaphragms are of especially prepared asbestos fabric of a thickness and texture carefully worked out by long experiment.

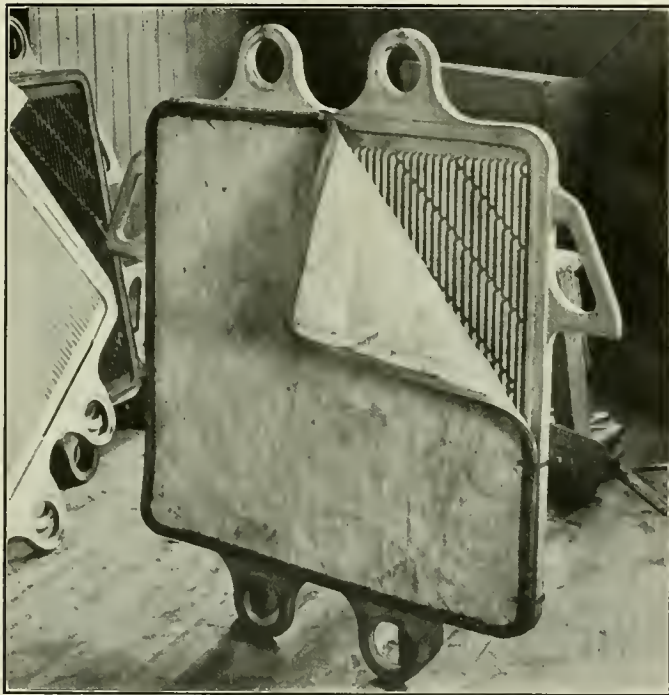

One of the Electrodes with Its Diaphragm

All around the edge of this fabric is moulded a packing rim of pure rubber, which rests in a recessed groove on the face of the electrode.

The electrodes are insulated from the side bars of the frames by porcelain insulators resting on a wooden bar in the large machine and on fibre in the small machine. They are insulated from one another by the rubber packing rim surrounding the diaphragm and by nipples of pure rubber inserted in the water intake and gas outlet openings. When the device is assembled these nipples provide an insulating tube between the water intakes and gas outlets.

To guard against grounding the apparatus through the small percentage of electrolyte which the gas carries with it from the cells, there is provided in the gas outlet system insulating pipe sections, each consisting of two sections of heavy glass tube clamped between iron flanges and so devised as to intercept and drain off through an insulating connection the moisture entrained

in the gases. The gases leave these insulators substantially dry and free from electrolyte.

A number of features contribute toward a high electrical efficiency with this generator. The use of the patented nickel anode and iron cathode has been found to materially facilitate the electrolysis. The design of the generator is such as to retain within the apparatus most of the heat produced as a result of the ohmic resistance. This keeps the electrolyte and the electrodes at a comparatively high temperature, which adds to the efficiency of the electrolytic process. Furthermore, the solution of caustic potash has been found by experiment to utilize the current to best advantage.

The generator is filled, on starting the apparatus, with a solution of the electrolyte. As decomposition proceeds, water must be supplied to maintain the right level and the right density. On the front of the generator are two tanks or domes with glass water-level indicators which carry the solution. Pipes descend from these tanks to a water-feed manifold, which branches into two pipes connecting independently to the two water intakes to the cells and also into the two risers leading to two independent gas domes above. Into these domes the oxygen and hydrogen are separately discharged as generated, the gas outlets opening through an inverted U below the fluid level. Next to these domes is a feed-water tank discharging distilled water through a float-controlled valve, as needed, to the solution tanks on the front of the generator.

This water-feed device creates an absolute balance of pressure throughout the generator. This eliminates circulation through the diaphragms due to unequal pressures on their two sides, removing any tendency to cause a mingling of gases through the diaphragm and relieving the diaphragm material from all mechanical stresses. The water-feed is absolutely proportioned to, and under the control of, the rate of gas generation.

This balanced pressure in both gas outlets, due to the method of gas discharge, forbids any mixture of the gases and contributes to the balancing of pressures on the diaphragms.

The gases, escaping from the gas outlets, rise through the fluid in the gas domes and pass out through discharge pipes at the top of the domes, thence downward to purgers on either side. These purgers are closed boxes of cast-iron filled with water to a certain level. The gases escape below the surface of the water, pass upward through it, and emerge thence through the supply lines to the gas holders. These purgers serve to catch any entrained fluid in the gas, cool the gas and act as a check to protect the pressure system of the generator from any undue pressure in the gas-holders.

A signal whistle is provided, which gives notice when the level of the solution in the generator falls below the prescribed limit. Sight-feed indicators on the solution tank and gas domes show the fluid levels and reveal the generation of the gases. Gage glasses connecting with the electrodes at intervals along the generator indicate the level of the electrolyte in the body of the apparatus.

Drain valves are provided to permit the emptying of the generator when required. These are of the lever operated gate type, designed to obviate any leakage or wear due to the presence of solid matter in the fluid.

**CORROSIVE EFFECT OF ACETYLENE.**—With the increasing use of acetylene gas the risks of its corrosive effect on pipes and metal containers should be better known. Tests have shown that moist acetylene, as generated, attacked zinc, lead, brass and nickel to a slight extent; iron was affected six to seven times as much; but copper suffered more than any other metal tested. Copper was quickly changed into a soft, porous black mass. Tin, aluminum, bronze, german silver and solder were practically unaffected. Thus it would appear that copper and brass or other copper alloys should not be used as piping for acetylene-gas supplies, and that iron should be well tinned rather than galvanized or nickel plated.—*American Machinist*.



**MURRAY KEYOKE**

A new design of hinged coupler yoke has recently been placed on the market by the Keyoke Railway Equipment Company, Chicago. It differs from the hinged coupler yoke previously made by that company in that it has a pinless interlocking hinge instead of the pin hinge. Its construction is clearly shown in

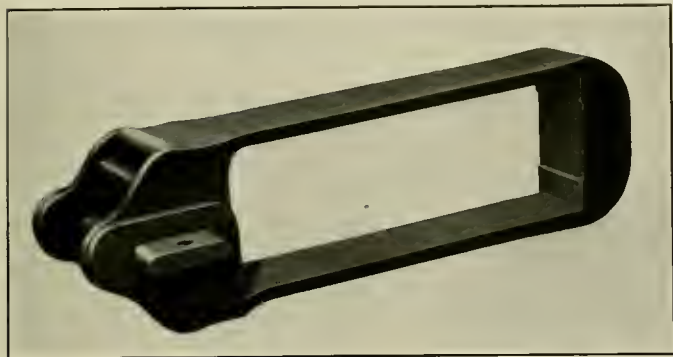

Fig. 1—Murray Keyoke

the illustrations. Fig. 1 shows the yoke in the closed position; Fig. 2 in the open position and Fig. 3 shows the yoke designed for use with a tandem spring gear. The yoke can be adapted for use with any design of draft gear. It is made of two open



Fig. 2—Keyoke Open

hearth thoroughly annealed steel castings, joined together at one end by the pinless interlocking hinge and at the other end by a standard 1½ in. by 5 in. coupler key.

The coupler end of the yoke is designed to fit accurately over

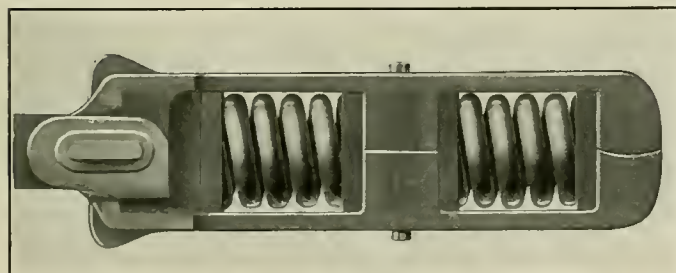

Fig. 3—Murray Keyoke for Tandem Spring Gear

the lugs on the end of the coupler, the pulling strains being taken on these lugs instead of on the coupler key, the latter serving principally to lock the yoke to the coupler. This feature is of special advantage in that the wings of the yoke will be subjected to but little stress, with the result that the key slots

will not wear as readily and become elongated. This eliminates the lost motion and prevents the opportunity of failure at this point. This design brings the load directly to the upper and lower members of the yoke. Destruction tests have shown that a yoke of this type having a cross section of 1 in. by 5 in. will fail at a load of 474,000 lb. in these members, while wrought iron yokes made of 1¼ in. by 5 in. material and riveted to the coupler failed at a load of 245,000 lb., due to the shearing of the rivets. The gibs of this latter type of yoke, which are simply bent in to engage the lugs on the end of the coupler, break off at 254,000 lb. With the key connection and the hinged end it is possible to replace the coupler with but little trouble, no riveting or other blacksmith work being required.

**VERTICAL MILLING MACHINE**

The illustration shows a redesign of the extra heavy vertical milling machine built by the Newton Machine Tool Works, Inc., Philadelphia, Pa. These machines have met with favor on account of the unusual flexibility of control, which permits a range of service from the successful use of end mills as small as ¾ in. in diameter, where the machines are used as die sinkers, to the heaviest of locomotive milling.

The design is especially adapted to alternating current motor drive, as, through the speed box gearing, changes are obtained without removal of gears. One of the essential features is the counterweighted spindle saddle with power vertical feeds and

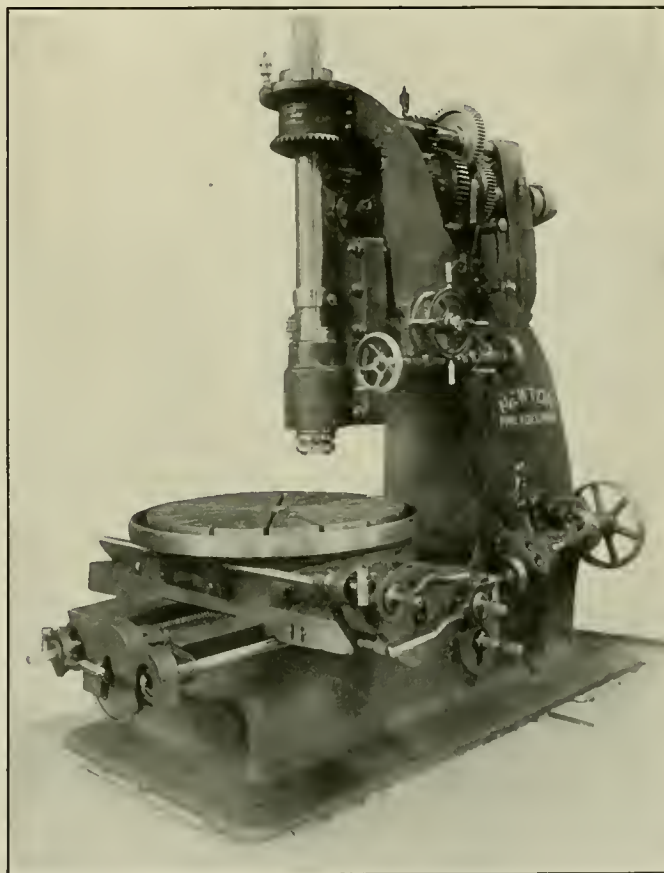

Redesigned Newton Vertical Miller

fast power movement. The circular, in and out and cross-table motions are provided with reversing fast power traverse. These motions also have reversing power feeds and hand adjustments, all controlled from a localized position. The diameter of the circular table over the slots is 42 in. It has a cross feed of 30 in. and an in and out feed of 20 in. The spindle has a range of speeds from 8½ to 232 revolutions per minute.

The table is of the center clamp construction and is surrounded

by a pan which is drained through the centre into a reservoir. When the circular table is in the forward central position the machine will mill up to 38 in. outside diameter with cutters 8 in. in diameter. When the table is adjusted to the extreme of the cross slide, it will mill 48 in. in outside diameter.

### UNWHEELING MALLET LOCOMOTIVES

The illustration shows a screw-jack locomotive hoist which has been developed especially to solve the problem of unwheeling Mallet compound locomotives in shops provided with no overhead service or with cranes of insufficient capacity. This crane was installed in the shops of the Missouri, Oklahoma & Gulf at Muskogee, Oklahoma, by the Whiting Foundry Equipment Company, Harvey, Ill.

In many shops where overhead cranes are in use the rigging ordinarily used with road engines is not adapted to the loads and peculiar construction of the Mallet engine; for handling with overhead cranes in a transverse shop a crane with three 75-ton trolleys would be required, and the supporting steel-work in most shops would require considerable strengthening to support the load.

With this hoist all of the wheels can be removed at one time without disconnecting the low-pressure engine. Five to six hours on the pit is all that is required to remove the wheels and lower engine on the shop trucks. One of its advantages is that it can be installed in any building, the hoists standing on their own foundations and being entirely independent of the building.

The hoist as shown is adjustable to any length of engine in service. By using two pairs of jacks all types of road engines may be unwheeled with equal facility; drivers up to 84 in. in diameter can be handled.

The operation when handling Mallet engines is as follows: The engine is spotted with the high-pressure cylinders over the lifting beam of the center hoist, which is stationary. This hoist

gear, the motor again started and the engine raised again until the wheels can be rolled out.

The lifting beams are dropped through slots in the track and have a section of track on top, thus allowing the engine to be run onto the hoist and spotted. Several slots in the track are arranged at proper distances for the two movable hoists, so that they may be adjusted to take any type of engine in service.

The lifting screws are carried on very heavy roller bearings between special hardened steel plates. The lifting speed is steady and slow.

### WOODARD THROTTLE

An outside connected throttle valve has been developed and patented by the American Locomotive Company, New York, by the use of which a throttle standpipe of the usual type is

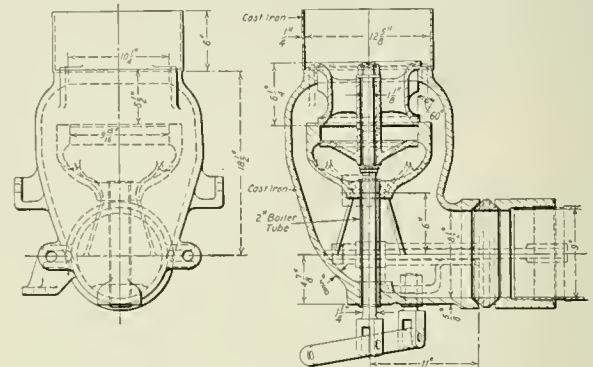

The Woodard Throttle

dispensed with. This device is known as the Woodard Throttle and is shown in the drawing. This permits the location of the entire dome rigging close to one side of the dome, leaving

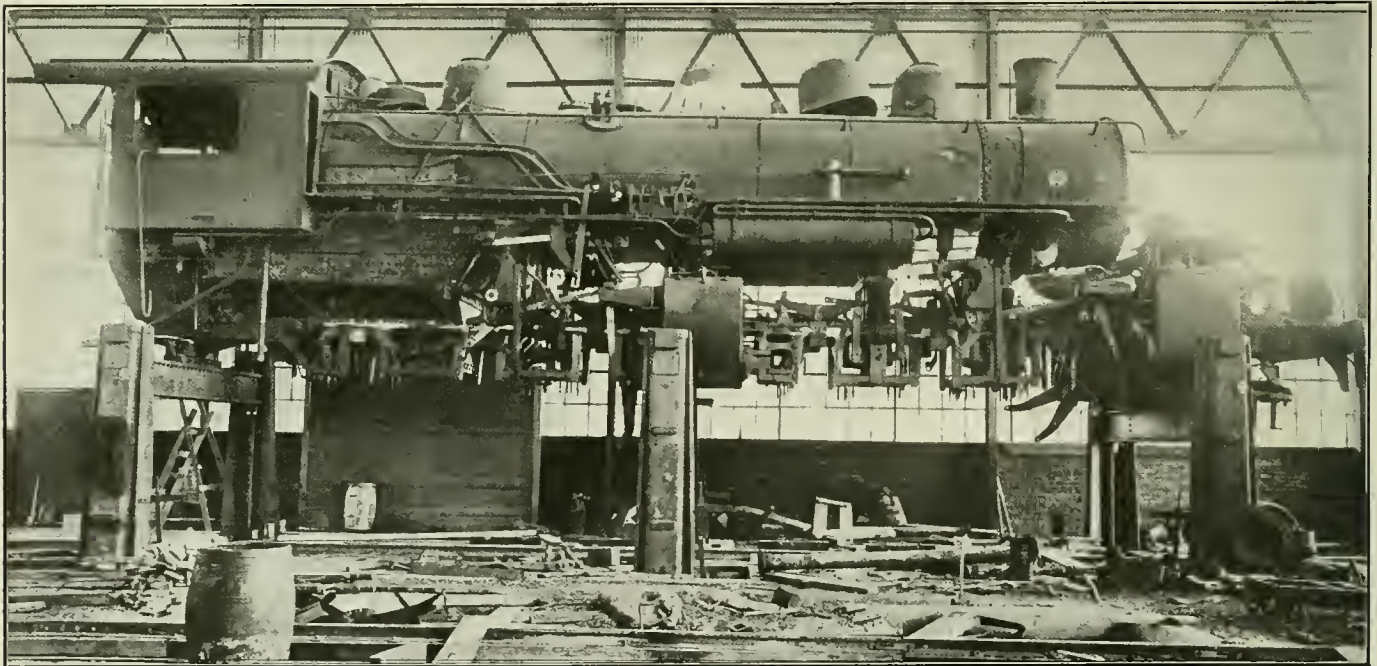

Whiting Locomotive Hoist Lifting a Mallet Engine

is thrown into gear and the beam brought up and proper blocking placed under the engine frame. The frames of high pressure and low pressure engines are clamped together, and the lifting beam under the low pressure cylinders is then brought into place and properly blocked; the beam under the rear end of the engine is finally brought into place and blocked. After all the beams are in proper position the motor is stopped, all hoists thrown into

room at one side to enter the dome without disturbing the throttle chamber and its connections.

The lower valve seat is enclosed within the throttle chamber, being supported by ribs extending to the sides of the chamber. A cavity is thus formed within the chamber which is always open to boiler pressure. A passage leads from this cavity down through the chamber, through which passes the valve stem. This

passage is formed of a short piece of 2-in. boiler tube expanded into the casting at both ends, thus closing it from communication with the interior of the throttle chamber.

At the lower end of the throttle stem is a horizontal lever pivoted to the chamber casting, one end of which connects through a vertical rod with the inner arm of the operating shaft. This shaft extends through a stuffing box in the side of the dome of ordinary construction suitable for a rotating shaft. The throttle rod is connected to an arm on this shaft, outside of the dome, the outer end of the shaft being supported in an arm cast integral with the stuffing box.

**FLEXIBLE PIPE CONNECTION**

A new type of McLaughlin flexible conduit has recently been developed for use between the engine and tender. As shown in the photograph, this is made in both single and double types, the

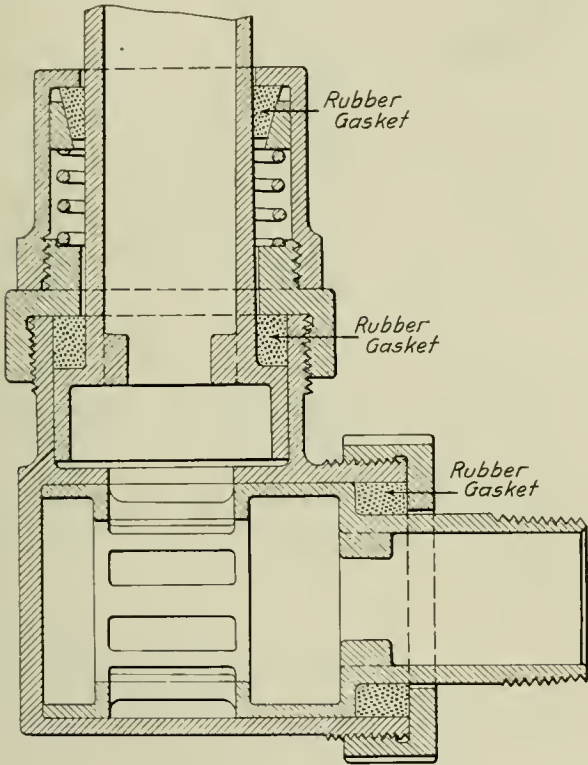

Details of Construction of the Double Connection

construction of the latter being clearly indicated in the drawing. The single joint is similar to the horizontal part of the double joint.

The principal feature of the double joint is the use of two

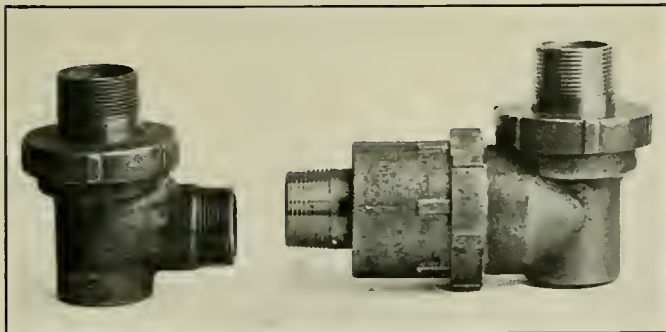

Single and Double McLaughlin Flexible Connections

gaskets on the vertical branch. The device hangs near the center of gravity and is claimed to be less liable to leak than other similar devices. Should the main gasket become worn or

break because of excessive wear from the weight of the conduit, the upper gasket will still prevent leakage. The lower or horizontal part of the joint is of ample proportions, thus reducing the friction through the joint to a minimum.

A consideration of importance in connection with this joint is the freedom of movement at all angles.

**POST HAMMER**

A light power hammer has been placed on the market by the Q M S Company, Chicago. The design is such that the hammer is easy to install wherever either steam or compressed air is obtainable.

The high price of tool steel makes it a valuable adjunct in any machine shop, where it may be used to draw down short pieces of tool steel, such as are usually scrapped, into small cut-

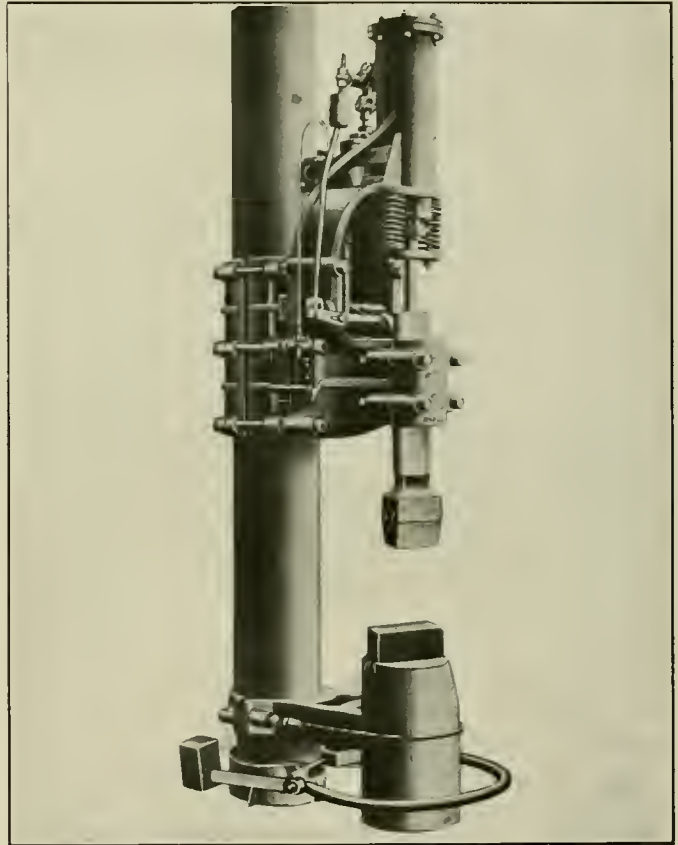

Post Hammer Driven by Steam or Compressed Air

ting tools for use in lathe tool holders. It is adaptable to all classes of light forging, as it may be easily handled by the blacksmith. The services of a helper are unnecessary.

The hammer is provided with a patent valve movement, which insures perfect control of the blow. If the treadle is brought down to the limit of its movement, the ram will strike a hard full blow, the same as a drop-hammer. When the treadle is pressed down part way the ram will give repeated blows, either hard or light, as may be required. The change from hard to light blows is made instantly and smoothly.

TRUING OILSTONES.—To true an oilstone, take a piece of soft pine board of any thickness, about 8 in. wide and 3 ft. or 4 ft. long. Lay it on a bench and fasten it with a handscrew or other clamp. Put on some clean, sharp sand screened about as fine as that used for plastering work. Use no water, and rub the stone back and forward over the board in sand. This will give a flat surface to the stone in a short time, which may be finished with fine sand or sandpaper.—*Mechanical World*.

# Railway Mechanical Engineer

INCLUDING THE  
AMERICAN ENGINEER

PUBLISHED ON THE FIRST THURSDAY OF EVERY MONTH BY THE  
SIMMONS-BOARDMAN PUBLISHING COMPANY

EDWARD A. SIMMONS, *President*                      L. B. SHERMAN, *Vice-President*  
HENRY LEE, *Secretary-Treasurer*  
WOOLWORTH BUILDING, NEW YORK, N. Y.

Chicago: Transportation Bldg.                      Cleveland: Citizens' Bldg.  
London: Queen Anne's Chambers, Westminster.

ROY V. WRIGHT, *Editor*  
R. E. THAYER, *Associate Editor*                      A. C. LONDON, *Associate Editor*  
C. B. PECK, *Associate Editor*

Entered at the Post Office at New York, N. Y., as mail matter of the second class.

Subscriptions, including the eight daily editions of the *Railway Age Gazette* published in June in connection with the annual conventions of the Master Car Builders' and American Railway Master Mechanics' Associations, payable in advance and postage free: United States, Canada and Mexico, \$2.00 a year; Foreign Countries (excepting daily editions), \$3.00 a year; Single Copy, 20 cents.

WE GUARANTEE, that of this issue 7,800 copies were printed; that of these 7,800 copies 6,800 were mailed to regular paid subscribers, 588 were provided for counter and news companies' sales, 97 were mailed to advertisers, exchanges and correspondents, and 315 were provided for new subscriptions, samples, copies lost in the mail and office use; that the total copies printed this year to date were 7,800, an average of 7,800 copies a month.

The RAILWAY MECHANICAL ENGINEER, and all other Simmons-Boardman publications are members of the Audit Bureau of Circulations.

VOL. 90

JANUARY, 1916

NUMBER 1

## CONTENTS

### EDITORIALS:

Our Change in Name.....	1
Steel Freight Car Competition Award.....	1
Records of Defects in Equipment.....	1
Conservation of High Speed Steel.....	1
Pitting of Boiler Tubes and Shells.....	1
The Engine Terminal Competition.....	2
Injector Steam Pipe Failures.....	2
A Competition for Apprentices.....	2
Systematic Promotion of Men.....	2
Electrification and Smoke Inspection in Chicago.....	3
New Books.....	3

### GENERAL:

Two Powerful 4-6-2 Locomotives.....	4
Failure of Fusible Tin Boiler Plugs.....	10
Suggestions for Team-Work in Saving Coal.....	10
Smoke and Electrification in Chicago.....	11
Operation of Radial Coupled Axles.....	15
Examples of Recent Switching Locomotives.....	20

### CAR DEPARTMENT:

Auxiliary Car for Wrecking Crane.....	21
The Cause of Shocks in Long Freight Trains.....	21
Wheel Clamp and Jack Block.....	22
Steel End Box Cars for the Santa Fe.....	23
Some Lessons from Experience with Steel Freight Cars.....	26
Vacuum Cleaner.....	27
Four-Wheel Trucks for Passenger Cars.....	27
A Suggestion for Composite Freight Car Construction.....	29
The Life of a Steel Freight Car.....	29
Inspecting Cast-Iron Wheels Under Freight Equipment.....	30

Finishing Car Journal Brasses.....	31
Making Efficient Car Inspectors.....	31

### SHOP PRACTICE:

Efficient Reclamation of Bolts and Nuts.....	33
Radial Drill Chuck for Locomotive Cylinders.....	35
Getting the Most Out of Tools.....	35
Making Bottom Brake Rods Without Welds.....	37
Expanding Mandrel for Turning Locomotive Tires.....	37
Comparative Locomotive Shop Ratios.....	38
Bracket for Safety Valve Test Gage.....	39
Piston Valve Packing.....	39
Help the Apprentices to Help Themselves.....	40
Supporting Shafting in Concrete Buildings.....	40
Report of the Chief Inspector of Locomotive Boilers.....	41
How Can I Help the Apprentice?.....	43
Portable Kerosene Vaporizer.....	43
Quick Adjustment Planer Clamps.....	44
Suggestions on Apprenticeship.....	44
Special Tool Holder for Broken Drills.....	44

### NEW DEVICES:

Large Pneumatic Riveter.....	45
Bipolar Oxygen and Hydrogen Generator.....	45
Murray Keyoke.....	47
Vertical Milling Machine.....	47
Unwheeling Mallet Locomotives.....	48
Woodard Throttle.....	48
Flexible Pipe Connection.....	49
Post Hammer.....	49

### NEWS DEPARTMENT:

Notes.....	50
Meetings and Conventions.....	51
Personals.....	52
Supply Trade Notes.....	54

## NEWS DEPARTMENT

The shops of the Missouri, Kansas & Texas at Sedalia, Mo., have been ordered to run seven days in the week; nine hours a day on week days and eight hours on Sunday.

The College of Engineering of the University of Illinois has received a Mogul type locomotive from the Illinois Central. It has 19-in. by 26-in. cylinders, and weighs with its tender 206,000 lb. It was taken from service and put through general repairs before delivery to the university. The locomotive will be used under the general direction of Prof. E. C. Schmidt for instructional work in the locomotive laboratory.

The "post office" or mail room in the general office building of the Baltimore & Ohio at Baltimore is now equipped with lock boxes, in the same style as a government post office; and each office in the building, having a key to the box assigned to it in the mail room, sends for its letters at any time of the day or night, as may be desired. This mail room at Baltimore handles about 35,000 pieces of mail every 24 hours, most of these being of course railroad service letters.

The executive committees representing the Brotherhood of Locomotive Engineers, the Brotherhood of Locomotive Firemen and Enginemen, the Brotherhood of Railway Trainmen and the Order of Railway Conductors at a meeting in Chicago on December 15, 16, 17, 18, 19 and 20, formulated demands to be presented to all the railroads in the country, providing for an eight-hour day or 12½ miles an hour speed basis in freight and yard service and time and one-half for overtime, with no change in the present schedules as to passenger service. The form of the proposed changes in the present agreements with the railroads expiring about April 30, 1916, are to be submitted to a referendum vote of the membership of the organizations.

The University of Illinois has maintained 10 research fellowships of \$500 each for graduate work in the Engineering Experiment Station since 1907. Last spring four additional research

fellowships were created, making 14 in all. There will be five vacancies in these fellowships at the close of the current academic year and nominations for the places will be made from applications received by the director before February 1. Appointments are open to graduates of approved American and foreign universities and technical schools. If accepted, the student must remain two consecutive college years.

**CAR AND LOCOMOTIVE ORDERS IN 1915**

According to statistics compiled by the Railway Age Gazette, the railways and other purchasers of cars and locomotives in the United States, Canada and Mexico placed orders either with manufacturers or company shops during 1915 for 109,792 freight cars, 3,101 passenger cars and 1,612 locomotives. In addition to this the car and locomotive builders received orders from railways in foreign countries, notably the State Lines of Russia and France, for at least 18,222 freight cars and 850 locomotives. The domestic figures alone show an increase of about 40 per cent over 1914 when there were ordered for domestic use 80,264 freight cars, 2,002 passenger cars and 1,265 locomotives. The most remarkable thing about the year's business, however, is the fact that approximately one-half the domestic orders for the year were placed after the first of October.

The output for the year was exceedingly disappointing, there having been built only 74,112 freight cars, 1,949 passenger cars and 2,085 locomotives, the output for cars being the lowest since 1904 and that of locomotives the lowest since 1898. Of the 74,112 freight cars built, 14,128 were for export and of the 2,085 locomotives, 835 were for export.

The orders reported in the month of December were as follows:

	Locomotives	Freight Cars	Passenger Cars
Domestic .....	178	12,109	508
Foreign .....	11	.....	...
Total .....	189	12,109	508

Among the important orders for locomotives were the following: Erie, 10 Pacific type locomotives, American Locomotive Company; Lehigh Valley, 10 Mikado locomotives, Baldwin Locomotive Works; and Canadian Government, 15 Consolidation and 10 Pacific type locomotives, Canadian Locomotive Company.

The freight car orders included the following: New York, New Haven & Hartford, 500 coal cars, Standard Steel Car Company; New York, Ontario & Western, 400 hopper cars, Cambria Steel Company, and 100 gondola cars, American Car & Foundry Company; Duluth & Iron Range, 500 ore cars, Standard Steel Car Company, 250 ore cars and 100 flat cars, American Car & Foundry Company; Duluth, Missabe & Northern, 1,000 ore cars, Western Steel Car & Foundry Company, and 200 general service cars, Pullman Company; Erie, 500 gondola cars, American Car & Foundry Company, and 1,000 hopper gondola cars, Pressed Steel Car Company; the Delaware, Lackawanna & Western, 1,000 box cars, American Car & Foundry Company, 300 gondola cars, Barney & Smith Car Company, and 200 gondola cars, Standard Steel Car Company; Pennsylvania Lines West, 1,000 gondola cars, American Car & Foundry Company, and 1,150 gondola cars, Haskell & Barker Car Company.

From the standpoint of passenger cars, the month of December was one of the best for the entire year. The orders included: Missouri, Kansas & Texas, 15 baggage, 4 dining and 2 postal cars, American Car & Foundry Company; Chicago, Burlington & Quincy, 8 dining, 9 passenger and baggage, 15 coaches, 15 chair, 2 coach and smoking and 5 postal cars, American Car & Foundry Company; Pennsylvania Lines West, 12 baggage and mail and 6 dining cars, Pullman Company, 22 coaches and 7 passenger baggage cars, Pressed Steel Car Company, and 24 baggage cars, Standard Steel Car Company; Pennsylvania Lines East, 21 baggage and 5 horse-express cars, American Car & Foundry Company, 6 coaches, Pressed Steel Car Company, 47 coaches, Harlan & Hollingsworth Corporation, and 28 baggage cars, J. E. Brill Company; and the New York Central Lines,

15 coaches for the Cleveland, Cincinnati, Chicago & St. Louis, Barney & Smith Car Company, 25 coaches for the Boston & Albany, and 20 for the New York Central, Osgood Bradley Car Company, 15 coaches for the Michigan Central, American Car & Foundry Company, and 30 coaches for the New York Central, American Car & Foundry Company.

**EXTENSION OF TIME TO COMPLY WITH SAFETY APPLIANCE ACTS**

The Interstate Commerce Commission has granted a further extension of 12 months from July 1, 1916, to the time within which the carriers must make their freight train cars conform to the safety appliance acts. By an order of the commission dated March 13, 1911, issued in conformance with an act of Congress approved April 14, 1910, the carriers were allowed an extension of time of five years from July 1, 1911. By the present order the former order is extended one year.

The commission's order of March 13, 1911, was as follows:

(a) Carriers are not required to change the brakes from right to left side on steel or steel underframe cars with platform end sills, or to change the end ladders on such cars, except when such appliances are renewed, at which time they must be made to comply with the standards prescribed in said order of March 13, 1911.

(b) Carriers are granted an extension of five years from July 1, 1911, to change the location of brakes on all cars other than those designated in paragraph (a) to comply with the standards prescribed in said order.

(c) Carriers are granted an extension of five years from July 1, 1911, to comply with the standards prescribed in said order in respect of all brake specifications contained therein, other than those designated in paragraph (a) and (b), on cars of all classes.

(d) Carriers are not required to make changes to secure additional end-ladder clearance on cars that have 10 or more inches end-ladder clearance, within 30 inches of side of car, until car is shopped for work amounting to practically rebuilding body of car, at which time they must be made to comply with the standards prescribed in said order.

(e) Carriers are granted an extension of five years from July 1, 1911, to change cars having less than 10 inches end-ladder clearance, within 30 inches of side of car, to comply with the standards prescribed in said order.

(f) Carriers are granted an extension of five years from July 1, 1911, to change and apply all other appliances on freight cars to comply with the standards prescribed in said order, except that when a car is shopped for work amounting to practically rebuilding body of car, it must then be equipped according to the standards prescribed in said order in respect to handholds, running boards, ladders, sill steps, and brake staffs: *Provided*, That the extension of time herein granted is not to be construed as relieving carriers from complying with the provisions of section 4 of the act of March 2, 1893, as amended April 1, 1896, and March 2, 1903.

(g) Carriers are not required to change the location of handholds (except end handholds under end sills), ladders, sill steps, brake wheels, and brake staffs on freight-train cars where the appliances are within 3 inches of the required location, except that when cars undergo regular repairs they must then be made to comply with the standards prescribed in said order.

The order applies only to paragraphs (b), (c), (d) and (f). As to the matters in the other paragraphs the carriers have already been granted an indefinite extension of time.

**MEETINGS AND CONVENTIONS**

*Master Boiler Makers' Association.*—The tenth annual convention of the Master Boiler Makers' Association will be held at the Hollenden Hotel, Cleveland, Ohio, May 23 to 26, inclusive, 1916.

*General Foremen's Association.*—The twelfth annual convention of the International Railway General Foremen's Association will be held at the Hotel Sherman, Chicago, Ill., August 29, 30, 31 and September 1, 1916.

*The American Society of Mechanical Engineers.*—The following is the list of the newly elected officers of the American Society of Mechanical Engineers for the coming year: D. S. Jacobus, president; W. B. Jackson, J. Sellers Bancroft and Julian Kennedy, vice-presidents; J. H. Barr, J. A. Stevens and H. deB. Parsons, managers, and W. H. Wiley, treasurer.

*Western Railway Club.*—At the December meeting of the Western Railway Club it was announced that hereafter the regular monthly meeting will be held in the Grand Pacific hotel, Chicago, the third Tuesday evening in every month, except June, July and August. Arrangements have also been made for those who remain in town for the meeting to have their dinner at the hotel in a special room that will be reserved for the club mem-

bers. This will present a good opportunity for a general get-together meeting before the paper of the evening is presented. It was also announced that a light luncheon will be served after the meeting, and in order not to make the meetings unduly late the speaker will be introduced promptly at 8 o'clock and the discussion will be closed at 9:30.

**Atlantic City Exhibits.**—The Railway Supply Manufacturers' Association has sent out an official circular relating to the exhibits at Atlantic City during the Master Car Builders' and American Railway Master Mechanics' conventions, which will be held June 14-21, 1916, in which it designates Friday, February 18, as the time at which assignments of space will be made. So many inquiries about space were received because of a preliminary circular which was sent out about a month ago that it is advisable for those who have exhibited in previous years and who expect to exhibit next June, to make immediate application to J. D. Conway, secretary-treasurer, Oliver Building, Pittsburgh, Pa. A number of improvements are to be made on the Million Dollar Pier, which will add to the exhibit space and also contribute to the convenience of the exhibitors. Aquarium Court will be rearranged, the spaces on the south side being extended 3 ft. out into the isle and the isleways on both sides being roofed over. The decorations in the main building at the entrance to the pier will be entirely new and even more attractively than in former years. No dividing rails will be permitted in Machinery Hall and its extension and the floors will be thoroughly cleaned and oiled. New matting will be used throughout this building as well as in all the other sections of the exhibit space. More or less trouble has been experienced in the past because of insufficient power. Arrangements have been made to insure an ample supply for the coming conventions. Applications for space will be considered in the order of their receipt and should be forwarded to Secretary Conway at once.

*The following list gives names of secretaries, dates of next or regular meetings and places of meeting of mechanical associations:*

- AIR BRAKE ASSOCIATION.—F. M. Nellis, 53 State St., Boston, Mass.
- AMERICAN RAILROAD MASTER TINNERS', COPPERSMITHS' AND PIPEFITTERS' ASSOCIATION.—W. E. Jones, C. & N. W., 3814 Fulton St., Chicago.
- AMERICAN RAILWAY MASTER MECHANICS' ASSOCIATION.—J. W. Taylor, Karpen Building, Chicago.
- AMERICAN RAILWAY TOOL FOREMEN'S ASSOCIATION.—Owen D. Kinsey, Illinois Central, Chicago.
- AMERICAN SOCIETY FOR TESTING MATERIALS.—Prof. E. Marburg, University of Pennsylvania, Philadelphia, Pa.
- AMERICAN SOCIETY OF MECHANICAL ENGINEERS.—Calvin W. Rice, 29 W. Thirty-ninth St., New York.
- ASSOCIATION OF RAILWAY ELECTRICAL ENGINEERS.—Joseph A. Andreucetti, C. & N. W., Room 411, C. & N. W. Station, Chicago.
- CAR FOREMEN'S ASSOCIATION OF CHICAGO.—Aaron Kline, 841 North Fiftieth Court, Chicago. Second Monday in month, except July and August, Lytton Building, Chicago.
- CHIEF INTERCHANGE CAR INSPECTORS' AND CAR FOREMEN'S ASSOCIATION.—W. R. McMurrin, New York Central, Albany, N. Y.
- INTERNATIONAL RAILWAY FUEL ASSOCIATION.—C. G. Hall, 922 McCormick Building, Chicago.
- INTERNATIONAL RAILWAY GENERAL FOREMEN'S ASSOCIATION.—William Hall, 1126 W. Broadway, Winona, Minn. Convention, August 29-31, 1916, Hotel Sherman, Chicago.
- INTERNATIONAL RAILROAD MASTER BLACKSMITHS' ASSOCIATION.—A. L. Woodworth, Lima, Ohio.
- MASTER BOILER MAKERS' ASSOCIATION.—Harry D. Vought, 95 Liberty St., New York.
- MASTER CAR BUILDERS' ASSOCIATION.—J. W. Taylor, Karpen Building, Chicago.
- MASTER CAR AND LOCOMOTIVE PAINTERS' ASSOCIATION OF U. S. AND CANADA.—A. P. Danc, B. & M., Reading, Mass.
- NIAGARA FRONTIER CAR MEN'S ASSOCIATION.—E. Frankenberger, 623 Brisbane Building, Buffalo, N. Y. Meetings monthly.
- RAILWAY STOREKEEPERS' ASSOCIATION.—J. P. Murphy, Box C, Collinwood, Ohio.
- TRAVELING ENGINEERS' ASSOCIATION.—W. O. Thompson, N. Y. C. R. R., East Buffalo, N. Y.

## PERSONALS

*It is our desire to make these columns cover as completely as possible all the changes that take place in the mechanical departments of the railways of this country, and we shall greatly appreciate any assistance that our readers may give us in helping to bring this about.*

### GENERAL

R. E. ANDERSON has been appointed air brake instructor of the Chesapeake & Ohio, with headquarters at Richmond, Va.

P. CONNIFF, superintendent of shops of the Baltimore & Ohio, at Mount Clare, Baltimore, Md., has been appointed special inspector of the mechanical department.

H. C. MAY, superintendent of motive power of the Chicago, Indianapolis & Louisville, has been appointed to the same position on the Lehigh Valley, with office at South Bethlehem, Pa succeeding F. N. Hibbits, resigned.

J. J. MCNEILL, road foreman of engines for the Erie at Cleveland, Ohio, has been appointed supervisor of locomotive operation, with office at Youngstown, Ohio, succeeding D. J. Madden, promoted.

### MASTER MECHANICS AND ROAD FOREMEN OF ENGINES

JOSEPH BLUETGE has been appointed road foreman of engines for the Erie at Cleveland, Ohio, succeeding J. J. McNeill, promoted.

B. CORBETT has been appointed master mechanic of the Missouri, Kansas & Texas at Smithville, Tex., succeeding J. R. Greiner, resigned.

H. A. ENGLISH has been appointed master mechanic of the Canadian Northern, central division, with office at Winnipeg, Man., succeeding G. H. Hedge, promoted.

G. H. HEDGE, master mechanic of the central division of the Canadian Northern, has been appointed general master mechanic of western lines, with office at Winnipeg, Man.

G. H. NOWELL, formerly locomotive foreman of the Canadian Pacific at Cranbrook, B. C., has been appointed district master mechanic at Nelson, B. C.

J. W. TENNEY has been appointed road foreman of equipment, Chicago, Rock Island & Pacific, with headquarters at Trenton, Mo., succeeding M. J. McDonald, promoted.

F. J. YONKERS has been appointed road foreman of equipment for the Colorado division of the Chicago, Rock Island & Pacific, with headquarters at Goodland, Kan.

### CAR DEPARTMENT

T. C. CHOWN has been appointed acting assistant works manager at the Angus car shops of the Canadian Pacific, Montreal, during the absence of L. C. Ord.

A. GREY, assistant car foreman of the Canadian Northern at Winnipeg, has been appointed car foreman at Lucerne, B. C.

## RAILROAD CLUB MEETINGS

Club	Next Meeting	Title of Paper	Author	Secretary	Address
Canadian	Jan. 11	Yard Operation Modern Roundhouse Methods and Facilities	{ J. R. Hamilton J. H. De Salis }	James Powell	St. Lambert, Que.
Central	Jan. 14		Harry D. Vought	95 Liberty Street, New York	
New England	Jan. 11	Physical Valuation of Railroads	F. C. Shepherd	Wm. Cade, Jr.	683 Atlantic Avenue, Boston, Mass.
New York	Jan. 21	Modern Brake Apparatus	Dr. S. W. Dudley	Harry D. Vought	95 Liberty Street, New York
Pittsburgh	Jan. 28	Fuel Economy	H. C. Woodbridge	J. B. Anderson	207 Penn Station, Pittsburgh, Pa.
Richmond	Jan. 10	Transportation in Alaska	W. R. Crane	F. O. Robinson	C. & O. Ry., Richmond, Va.
St. Louis	Jan. 14	Useful Personality	V. L. Price	B. W. Frauenthal	Union Station, St. Louis, Mo.
South'n & S'w'rn	Jan. 18			A. J. Merrill	Box 1205, Atlanta, Ga.
Western	Jan. 18			Jos. W. Taylor	1112 Karpen Bldg., Chicago, Ill.
Western Canada	Jan. 10			Louis Kon	Box 1707, Winnipeg, Man.

J. E. HUGHES, car foreman of the Canadian Pacific at Union Station, Toronto, has been made car foreman in charge of general repairs at North Bay, Ont., succeeding J. Cowley, who is on extended leave of absence.

J. JOLLY has been appointed car foreman of the Canadian Pacific at Lambton, Ont., succeeding J. Bannon, transferred.

W. F. MILLER, heretofore car foreman of the Canadian Northern at Parry Sound, Ont., has been appointed car foreman at Toronto, Ont.

L. C. ORD, assistant works manager, Angus car shops, Montreal, Que., of the Canadian Pacific, has been granted leave of absence to enter active service, as lieutenant in No. 1 overseas battery of the siege artillery, Canadian expeditionary force. Mr. Ord has left for the front.

### SHOP AND ENGINE HOUSE

O. S. BEYER, JR., general foreman of the Horton, Kan., shops of the Chicago, Rock Island & Pacific, has been appointed first assistant in the engineering experiment station in the department of railway engineering of the University of Illinois.

C. BOARDMAN, foreman in the Winnipeg shops of the Canadian Pacific, has been appointed locomotive foreman at Red Deer, Alta., succeeding C. A. Little, transferred.

E. J. BRENNAN, formerly division master mechanic of the Buffalo, Rochester & Pittsburgh at Du Bois, Pa., has been appointed superintendent of shops of the Baltimore & Ohio, at Glenwood, Pittsburgh, Pa.

G. CANFIELD has been appointed locomotive foreman of the Canadian Northern at Jellicoe, Ont.

M. A. CARDELL has been appointed locomotive foreman of the Canadian Northern at Tollerton, Alta.

P. CARLISLE has been appointed roundhouse foreman of the Intercolonial at Moncton, N. B.

F. CARROLL has been appointed foreman blacksmith of the Intercolonial at Moncton, N. B., succeeding A. Stockall, retired.

L. FINEGAN, superintendent of shops of the Baltimore & Ohio at Glenwood, Pittsburgh, Pa., has been appointed superintendent of shops at Mount Clare, Baltimore, Md., succeeding P. Conniff, assigned to other duties.

A. FOURNIER has been appointed locomotive foreman of the Canadian Northern at Sudbury, Ont.

O. C. GRANT has been appointed locomotive foreman of the Canadian Northern at Parry Sound, Ont.

L. B. LARSON, formerly locomotive foreman for the Chicago & Alton at Kansas City, Mo., has been appointed erecting shop foreman in the shops of the Oregon Short Line at Pocatello, Idaho.

H. N. LUKES, assistant air brake inspector of the Canadian Northern, has been appointed locomotive foreman at Blue River, B. C.

A. MALLINSON has been appointed locomotive foreman of the Canadian Northern at Capreol, Ont.

E. J. MURPHY, assistant locomotive foreman of the Canadian Pacific at Lambton, Ont., has been made locomotive foreman, succeeding F. Ronaldson, promoted.

I. C. NEWMARCH, general foreman in the Collinwood, Ohio, locomotive shops, of the New York Central, has been appointed superintendent of shops at Collinwood, succeeding R. H. Montgomery, deceased.

T. RYAN has been appointed roundhouse foreman of the Intercolonial at Riviere du Loup, Que., succeeding V. Saindon, who has been assigned to other duties.

J. H. THOMPSON has been appointed locomotive foreman of the Canadian Northern at Ottawa, Ont.

### PURCHASING AND STOREKEEPING

E. J. ALEXANDER, second assistant to the receiver, has been appointed fuel agent of the Chicago & Eastern Illinois, succeeding C. G. Hall, resigned to become secretary of the Northern Indiana Coal Trade Bureau.

C. L. BANKSON has been appointed assistant purchasing agent of the Great Northern, with office at Seattle, Wash., succeeding A. Watson.

A. S. BROWN has been appointed storekeeper of the Salt Lake & Ogden, with office at Salt Lake City, Utah, succeeding W. H. Bliss, resigned.

E. HUMPHRYS, fuel agent of the Canadian Pacific, has been appointed storekeeper of the Manitoba division at Winnipeg, Man., and the duties of fuel agent are incorporated with those of the latter position.

### OBITUARY

WILLIAM C. HAYES, superintendent of locomotive operation of the Erie at New York, died on December 25 at his home in New York.

THOMAS J. HENNESSEY, formerly division master mechanic of the Michigan Central at Bay City, Mich., died on December 4, 1915. Mr. Hennessey was born in London, Ontario, on January 1, 1845. He began his railroad career as a fireman on the Michigan Central in 1872 and became an engineer in 1874. In 1889 he was made traveling engineer, which position he occupied till he was appointed division master mechanic at Detroit in 1893. Mr. Hennessey successively served in a similar capacity at Jackson and Bay City, Michigan, being transferred to the latter point early in 1902. Here he remained until retired from the service, on reaching the age limit, in February, 1915.

JOHN KIRBY, general master car builder of the Lake Shore & Michigan Southern from October, 1870, to October, 1892, died on December 8, at Adrian, Mich. Mr. Kirby was born in October, 1823, in Oxfordshire, England, and was educated in the common schools. He began railway work in May, 1848, and until 1854 was engaged in repairing cars on the Syracuse & Utica, which is now a part of the New York Central. He was then engaged in repairing and building cars on the Michigan Southern at Adrian, Mich. From September, 1856, to September, 1858, he was foreman of shops at Adrian; then to October, 1870, was master car builder of the Michigan Southern & Northern Indiana, which subsequently became a part of the



J. Kirby

Lake Shore & Michigan Southern. In October, 1870, he was appointed general master car builder of the Lake Shore & Michigan Southern, remaining in that position until October, 1892. Mr. Kirby was president of the Master Car Builders' Association in 1891 and 1892, and from 1900 to 1909 was treasurer of the same association.

## SUPPLY TRADE NEWS

Wilfred R. Dean, vice-president of the Dean Brothers Pump works, Indianapolis, Ind., died recently, after a prolonged illness.

Frank R. Peters, formerly with J. Stone & Co., London, has joined the electrical staff of the Franklin Railway Supply Company.

S. K. Smith, treasurer of the Harlan & Hollingsworth Corporation, has also been elected vice-president, succeeding Persifor Frazer.

The American Steel Foundries have taken over the Elliott brake beam safety hanger hitherto handled by the Elliott Company, of Philadelphia.

H. E. Walker, for several years New York representative of the S. K. F. Ball Bearing Company, Hartford, Conn., has severed his connection with that company.

The Burdett Oxygen Company completed a new plant at Ft. Worth, Tex., on December 15. This is the ninth plant to be erected by the company in various industrial centers of the country.

George R. Henderson, consulting engineer of the Baldwin Locomotive Works, has resigned from that position and opened an independent office as consulting engineer at 1321 Walnut street, Philadelphia, Pa.

Frank Howard Bailie, assistant manager of sales of the H. K. Porter Company, Pittsburgh, Pa., died after a brief illness from pneumonia on Tuesday, December 14. Mr. Bailie had been associated with the company for 27 years.

B. H. Forsyth, who for the past three years has been connected with the sales department of the Hale & Kilburn Company, with office at Chicago, and formerly sales manager of the Ford & Johnson Company, resigned, effective January 1.

Flint & Chester, Inc., New York, have taken the exclusive sales agency for the United States and Canada for the National Graphite Lubricator Company, Scranton, Pa. The lubricators made by the latter have been adopted by 11 railroads and installed on 40 others.

James Mapes Dodge, chairman of the board of directors of the Link-Belt Company, Chicago, Ill., died at his home in Philadelphia, September 4. Mr. Dodge was born June 30, 1852, at Waverly, N. J. He studied three years at Cornell University and then took a special one-year course in chemistry at Rutgers. After spending a short time at the Morgan Iron Works in New York, he entered the shops of James Roach, the shipbuilder, at Chester, Pa., where, during a three years' stay, he was successively journeyman, foreman and superintendent of erection. About 1880 he became acquainted with William D. Ewart, the inventor of the Ewart link-belt, and soon after joined him and his associates in the development of the chain business, which at that time had not attained a very great importance. He later entered into a partnership with Edward H. Burr, under the name of Burr & Dodge, who represented in Philadelphia the Ewart Manufacturing Company of Indianapolis, then manufacturing the Ewart detachable link-belt. Out of this partnership grew the Link-Belt Engineering Company, organized in 1888. In 1889 Mr. Dodge brought out the Dodge system of storing anthracite coal in large conical piles and reloading it by machinery. For this invention he received in 1907 the Elliott Cresson gold medal from the Franklin Institute. In 1892 Mr. Dodge was elected president of the Link-Belt Engineering Company and the Dodge Coal Storage Company (later called the J. M. Dodge Company). He became chairman of the board of directors of the Link-Belt Company when it was organized in 1906 through the merger of the allied companies—the Link-Belt Engineering Company, Philadelphia; the Link-Belt Machinery Company, Chi-

cago, and the Ewart Manufacturing Company, Indianapolis, at which time Charles Piez became president of the Link-Belt Company. Mr. Dodge has been a very successful inventor. He took out over 100 patents, among them, of course, being many relating to the construction and manufacture of silent chain.

C. W. Cross, from 1906 to 1914 superintendent of apprentices of the New York Central Lines, has been elected vice-president of the Equipment Improvement Company, with office at 30 Church street, New York. Mr.



C. W. Cross

Cross started his railroad career as a machinist apprentice on the Cincinnati, Hamilton & Dayton at Lima, Ohio. From 1880 to 1890 he was, respectively, a machinist, draftsman, foreman and assistant master mechanic in the shops of the Pennsylvania Lines at Fort Wayne, Ind. In 1890 he went to the Lake Shore & Michigan Southern as master mechanic at Elkhart, Ind., and became superintendent of apprentices for the New York Central Lines, with headquarters at New York, when that railroad revised and centralized its apprenticeship department in 1900. Mr. Cross has been a representative for the Equipment Improvement Company since July, 1914. He took up his new duties as vice-president on December 15.

Andrew J. Farley, vice-president of the Camel Company, and for many years secretary of the Chicago Railway Equipment Company, died on December 13, 1915, at the Hyde Park hotel, Chicago, Ill. Mr. Farley was born at Schuylerville, N. Y., in 1847, and spent his early life in Troy, N. Y., where he was, at one time, engaged in the retail business. His advent in the railway supply business was with the old Dunham Manufacturing Company. When he left this company he became connected with The National Brake Beam Company, now the Chicago Railway Equipment Company, with which he spent most of his business career. About five years ago he retired from active business and has lived most of each



A. J. Farley

year at his summer place at Wheaton, Ill., spending the winters in Chicago and California. He was one of the organizers of the Camel Company, and at the time of his death was vice-president. He is survived by his wife and one daughter, Mrs. James M. Hopkins.

The Youngstown Steel Car Company was recently organized at Youngstown, Ohio, to assume the business of the Youngstown Car & Manufacturing Company, designers and builders of in-



dustrial equipment. J. E. Tesseyman, formerly of the Ralston Steel Car Company, Columbus, Ohio, has assumed the duties of general manager, and plans are being formulated for enlarging the company's output. The company is entering the field of repairing steel cars, and is at present making prompt deliveries on pressed steel parts.

James Brown Rider has been elected vice-president and general manager of the Pressed Steel Car Company and the Western Steel Car & Foundry Company. Mr. Rider entered the service of



J. B. Rider

the Pennsylvania Railroad in 1895, and remained with it until 1899, acting successively as messenger boy, shop order clerk, invoice clerk and stenographer. In 1899 he became connected with the Pressed Steel Car Company as stenographer and clerk to the general manager, being advanced to the position of assistant to the vice-president in July, 1905. He was appointed general manager in July, 1909, and made a member of the board of directors in Jan., 1913. He was appointed general manager of the Western Steel Car & Foundry Company August, 1913. He is now elected a vice-president of the Pressed Steel Car Company and Western Steel Car & Foundry Company, with headquarters in Pittsburgh, Pa., and will also continue to perform the duties of general manager in charge of operation. His title is vice-president and general manager of both companies.

N. S. Reeder, vice-president of the Pressed Steel Car Company and the Western Steel Car & Foundry Company, graduated from Cornell University with the degree of mechanical engineer in 1896. He then served as a special apprentice on the Pennsylvania Lines West of Pittsburgh, and in 1899 was employed by the Pittsburgh Coal Company as superintendent of the Montour and Moon Run Railroads. In 1902 he entered the service of the Pressed Steel Car Company as a mechanical engineer connected with the New York office, but in 1904 he went to Montreal as assistant general manager of the Canada Car Company. In 1906 he was made general manager, and in 1908 became second vice-president of



N. S. Reeder

the Canadian Car & Foundry Company. He returned to the States in 1909 as vice-president of the Western Steel Car & Foundry Company, and in 1910 was made second vice-president of the Pressed Steel Car Company in Chicago. He is now transferred to the company's New York office, effective December 1.

J. F. McEnulty has been elected second vice-president of the Pressed Steel Car Company and the Western Steel Car & Foundry Company. Mr. McEnulty entered the employ of the



J. F. McEnulty

Pressed Steel Car Company in 1899, and has been its general sales manager since May, 1912. He was first an inspector at Pittsburgh, later being promoted to the positions of chief inspector, general chief inspector and engineer of construction. He was transferred to the sales department in New York in 1904, and in 1907 was made general superintendent of the Hege-wisch Works of the Western Steel Car & Foundry Company. In 1909 he was promoted to the position of general manager, and in May, 1912, returned to New

York as general sales manager of both the Pressed Steel Car Company and Western Steel Car & Foundry Company.

C. E. Postlethwaite, who since December 1 has been general sales manager of the Pressed Steel Car Company and the Western Steel Car & Foundry Company, with headquarters in New



C. E. Postlethwaite

York, was until that date manager of sales for the central district at Pittsburgh, Pa. He was born in Mount Union, Huntington county, Pa., and after graduating from the Altoona high school in 1883 entered the service of the Pennsylvania Railroad, where he remained until 1890, acting successively as rodman on an engineer corps, telegraph operator and Pennsylvania Railroad division car clerk. For the following seven years he was connected with the Norfolk & Western as chief clerk to the general superintendent at Roanoke, and

later as assistant to the general agent at Norfolk. He became connected with the Schoen Pressed Steel Car Company in October, 1897, shortly after the first steel freight cars were built, and remained with the company when it was merged into the Pressed Steel Car Company. Mr. Postlethwaite entered the sales department of the company in February, 1902.

A. F. Huston, president of the Lukens Iron & Steel Company, Coatesville, Pa., has recently announced that his company has placed an order for a plate mill which will be able to roll a plate 200 to 204 in. wide and which will be the largest plate mill in existence in the world at the present time.

Henry C. Kloos, of the electrical staff of the Pullman Company, has accepted a position with the Franklin Railway Supply Company, New York. This company is now engaging in the manufacture and sale of car lighting equipment, and is placing upon the American market the "Stone" system of car lighting,

hitherto manufactured in England and extensively employed abroad.

Henry Phipps Hoffstot has been appointed to the position of assistant manager of sales, central district, of the Pressed Steel Car Company, with headquarters at Pittsburgh, Pa. Mr. Hoff-

stot has been in the service of the company since 1910. He graduated from Harvard College in 1909, and in the same year entered the employ of the Canadian Car & Foundry Company at Montreal and Amherst, N. S. The following year he was appointed assistant to the general manager of the Pressed Steel Car Company, and on December 1 entered the sales department of the company as assistant manager of sales, central district, with headquarters at Pittsburgh, as above noted.



H. P. Hoffstot

Edward F. Carry, Chicago, has been elected president of the reorganized Haskell & Barker Car Company, of Michigan City, Ind. Mr. Carry was born in Fort Wayne, Ind., on May 16, 1867,

and was educated in the public schools of that city. He began his business career with the Wells & French Car Company, Chicago, and was secretary of this company at the time of its consolidation with the American Car & Foundry Company. He has served the latter company for 28 years as district manager, third vice-president, second vice-president and later as first vice-president and general manager. Since 1903 he has been a director and member of the executive committee of the company. Mr. Carry's election as presi-



E. F. Carry

dent of the Haskell & Barker Car Company was effective on January 1; he will take office on January 10, upon the completion of legal details. The following directors of the Haskell & Barker Car Company have been elected: Frank A. Vanderlip, president of the National City Bank; W. E. Corey, president of the Midvale Steel & Ordnance Corporation; Ambrose Monell, president of the International Nickel Company; Joseph W. Harriman, president of the Harriman National Bank; John Morron, president of the Atlas Portland Cement Company; E. S. Webster, Stone & Webster; A. O. Choate, Potter, Choate & Prentice; and Edward F. Carry. Two additional directors will be chosen later on. Mr. Carry has a large circle of friends among railway officers throughout the country. His home is in Chicago, with summer residence at Lake Forest, Ill.

W. L. Conwell, vice-president and treasurer of the Transportation Utilities Company, New York, has been appointed assistant to the president of the Safety Car Heating & Lighting Company,



W. L. Conwell

effective January 1. Mr. Conwell has been in the service of the Transportation Utilities Company since 1911. He was born at Covington, Ky., January 25, 1877. He received his education in the public schools of Philadelphia and at the University of Pennsylvania, from which he graduated in 1898 with the degree of electrical engineer. He then passed the examinations for first assistant engineer for the United States Navy, but received no appointment because of the cessation of hostilities. He was employed in contracting work as a time-keeper

for the Tennis Construction Company, Philadelphia, becoming later chief engineer and secretary of the company. In 1901 he resigned to become city salesman of the Westinghouse Electric & Manufacturing Company in New York. He was later placed in charge of the isolated plant department of the company, and for five years, ending in 1911, was engaged in railway work. He then became vice-president of the Transportation Utilities Company.

Paul M. Lincoln, for over 23 years connected with the operating and engineering activities of the Westinghouse companies, on January 1 became associated with the sales department



P. M. Lincoln

of the Westinghouse Electric & Manufacturing Company, with the title of commercial engineer. Mr. Lincoln, shortly after his graduation from Ohio State University in 1892, entered the employ of the Short Electric Company in Cleveland. He then went to the Westinghouse Electric & Manufacturing Company, and was engaged in the testing-room, and in general engineering work. When the plant of the Niagara Falls Power Company was opened he became its electrical superintendent, and as such had much to do with the

first transmission line to Buffalo. In 1902 he returned to the Westinghouse Company, specializing on the general engineering of power stations and transmission lines. He was for several years in charge of the power engineering department, but was transferred to the engineering department when that was organized. Mr. Lincoln is well known in engineering circles through his active work in the American Institute of Electrical Engineers, of which at one time he was president. He is a well-known writer on technical subjects and has also been identified with educational work for some time, filling the chair of professor of electrical engineering at the University of Pittsburgh.

# Railway Mechanical Engineer

Volume 90

February, 1916

No. 2

## Toning Up an Organization

Under this title three articles are reproduced on another page which were received in the competition that closed January 1, 1916. These articles, judged to be the best of those submitted, came from J. A. Pack, chief clerk in the motive power department of the Chesapeake & Ohio at the Huntington (W. Va.) shops; John V. Le Compte, foreman, motive power department, Baltimore & Ohio, Baltimore, Md.; and Millard J. Cox, assistant superintendent machinery, Louisville & Nashville, Louisville, Ky. The competition, as far as the number of letters received is concerned, did not come up to either the apprentice or car inspectors' competition, which were held last fall. This proved a big surprise, for much attention has been given to organization problems in the mechanical department in recent years and we really expected to be deluged with material.

## The Apprentice Competition

In our January issue, page 2, we had an extensive announcement of a competition for apprentices which is to close March 1, 1916. We want to know how the apprentice feels about the efforts which are being made to educate and train him for his life work? What things have proved most inspiring and helpful to him? What methods or practices in his course of training have made the greatest appeal to him? What can be done to make the course of training of greater practical value to him? Apprentices, or graduate apprentices, who have completed their courses since January 1, 1915, are eligible to take part in the competition. For the best letter on this subject, from a practical standpoint, which is received at our office in the Woolworth Building, New York, on or before March 1, 1916, and which does not contain more than 500 words, a prize of \$15 will be given. For the next best article \$10 will be paid. Other articles which may be accepted for publication will be paid for at our regular rates.

## Slack and Draft Gear Maintenance

That bug-a-bear—Slack! It causes break-in-twos, damaged freight, wrecked equipment and many a "Scotch blessing" from the road men, the officers and the shippers whose goods are damaged. Why not humor the beast? Any kind of draft gear, whether spring or friction, cannot be expected to perform its proper functions unless it is properly maintained. It has important work to perform—it must keep the slack to the proper amount and it must absorb the shocks incident to car movements. Unless it does these things it is not worth much more than the old link and pin connections of years ago. The fact that a highly improved and expensive draft gear has been placed on a car does not mean that the car will forever more be immune from the ravages of rough handling. It should be maintained the same as any other part of a car or locomotive. We will grant that it takes time and money properly to inspect the draft gears of every car and make repairs, but because of the trouble caused by excessive slack and the damage caused by ineffective draft gears, such labor and expense will be amply

justified. The next time the lamentations are heard, why not seek the root of the trouble; repair the gears and give them a chance to show what they can really do?

## Fuel Economies at Stationary Plants

Fuel is fuel no matter whether it is used on a locomotive or at a stationary boiler plant. It costs money wherever it is used. The fact that, comparatively speaking, but little is used at stationary plants does not mean that they are not worthy of inspection and improvement. That over 600 lb. of scale has been removed from a railroad stationary boiler by the application of a patented flue cleaner indicates that in some cases the supervision of stationary boiler plants is notoriously weak. Another instance might be mentioned of a plant operating in a bad water district. Excessive boiler trouble led to an investigation of the plant; an analysis of the boiler water after two successive "blow downs," two gages being blown out each time, showed 304 grains of incrusting solids. The feed water had been treated (?) and contained 35 grains. This boiler now operates with less than two grains and boiler troubles have been materially reduced. It is well known that scale is a poor conductor of heat. Why wait until it makes its presence known through the coal bill? A dollar saved at a stationary plant is as good as the dollar earned in carrying traffic. The work can be done at a small expense and the returns will make it well worth while.

## Passenger Car Terminal Competition

One exceedingly important part of the work of the car department has never received much recognition either in the railway technical publications or in the proceedings of the various mechanical department associations. Just why this is so it is difficult to understand, because it is one of those features which have much to do with the convenience, comfort and health of the traveler, and therefore merits prime consideration. It is the organization and methods of handling a passenger car terminal yard, first, so that the equipment may be made clean and sanitary and the supplies be properly replenished in order to please and protect the traveling public; and secondly, that the work may be carried on efficiently and economically. The work which is handled by the passenger car terminal force is a most difficult one and is often seriously complicated by stormy weather and delays to important passenger trains. The organization must have sufficient elasticity so that these difficulties may be overcome without neglecting the equipment or interfering with schedules. To place this subject on record and encourage as many of the car department foremen as possible to give us the benefit of their experience and views, we will give a prize of \$35 for the best article, from a practical standpoint, which is received in our offices in the Woolworth building on or before April 1, 1916. A second prize of \$25 will be given for the next best article, and others that are accepted for publication will be paid for at our regular rates. It is not necessary, in order to qualify, to discuss the subject in all its phases, or in its entirety. If you have had special experience along one line,

such, for instance, as the methods or details of the actual cleaning of the equipment, or looking after the supplies, or laying out a terminal yard in order that the work may be handled to the best advantage, or improving or perfecting the form of organization to insure the best results, or any one of a number of other different phases of this question, write about the particular thing with which you are most familiar. Remember that your personal co-operation, no matter to what extent you cover the subject, will be greatly appreciated by the editors and may be extremely helpful to your fellow workers on other roads as well.

**Cost  
Versus  
Service**

Innumerable are the opportunities for reductions in maintenance costs by a constant and careful analysis of methods, materials and new devices. Those mechanical departments which make an organized effort constantly to improve shop practices, details in locomotive and car construction and methods of handling equipment, are fully repaid for their efforts. With the ever-increasing ingenious devices placed at the disposal of the railways by the railway supply companies, the man who believes that the practices which proved satisfactory yesterday should answer for today is as valuable to his road as the old wood burners of years ago are to the railroad of today. Money spent for investigations and tests are sure to prove profitable investments in the long run. "Cost versus Service" should be the watchword. The fact that block tin has been used for lining crossheads for the past twenty years does not mean that a composition metal might not prove more economical, even though the crossheads have to be relined more often. Improved shop machinery and locomotive appliances and direct outlay of money for education of the employees all represent an expenditure that will give splendid returns on the investment. Men competent to make careful investigations, whether it be the mechanical engineer, the engineer of tests, or a special representative of the head of the mechanical department, should be placed in charge of this work.

**Feed  
Water Heater  
Question**

H. H. Vaughan, in addressing the American Society of Mechanical Engineers a little more than a year ago, made this statement: "This is a subject (feed water heaters) which American railroad people have largely neglected. It has the advantage of not only saving in coal, but increasing the capacity of the boiler. In careful experiments we found an economy of 12 per cent in the use of the heater \* \* \* ." For many years railroad officers have looked for a device of this kind, that locomotives might be operated more economically. Hundreds, possibly thousands, of experiments have been made, and many different designs have been tried out and discarded. Yet today this device has not passed the experimental stage in this country. The Prussian State Railways are said to have several thousand locomotives equipped with a type of feed water heater that gives something less than half the saving mentioned above.

As limitations of locomotive weight and size are being reached, and it is still desirable in many cases to make further increases in capacity, progress in the development of the device may be forced more because of this than because of the greater economy which may result from its use. The problems which confront the designer in developing a satisfactory feed water heater are most difficult ones, and their final solution may go hand in hand with other developments which could not be foreseen in the earlier stages of experimentation. In not a few cases attempts have been made to heat the water in the tender tank with the air-pump exhaust. Progress in this direction has been limited by the inability of the injector to handle water beyond a certain critical temperature and by the bursting of hose connections. The use of pumps instead of injectors and of flexible metallic connections between the tender and loco-

motives may overcome these difficulties, if the improved economy and capacity can be found to justify these changes.

Certain types of heaters have failed because of the water conditions. There are many things in connection with the treating of feed waters which are not thoroughly understood, and the development of the feed water heater may be hastened with their solution. Then, too, if certain types of locomotives should be fitted with a draft or blower device, such as has been designed by H. B. MacFarland, of the Santa Fe, some of the exhaust steam may be used for feed water heating purposes with good results. With many minds at work on the problem, and the knowledge gained from previous experiments, it would not be surprising if a distinct advance step was taken in the development of a successful device in the near future.

**Increased  
Locomotive  
Capacity**

Frequent reference is made in these days to the rapid growth in size and capacity of locomotives. The table herewith appended shows the average tons of freight per train mile, for each of the past six years, for a number of typical roads in various parts of the country. These figures are taken from the annual reports of the respective companies and, except where otherwise noted, are for the total freight carried, company and revenue. To some extent the figures reflect the growth in capacity of the modern freight locomotives; in most cases part of the increase in tonnage was made possible by the elimination of grades or curvature and by other engineering improvements or by the adoption of better operating practices. Remarkable results in some cases have followed campaigns of education, in which attempts were made to reach every employee who was at all concerned, or who could be helpful, in improving car or train-loading. In most instances, however, newer and larger locomotives, or the modernization of old power by the addition of capacity improving devices, has been an important factor in bringing about the larger average trainload:

Road	1915	1914	1913	1912	1911	1910
Atchison, Topeka & Santa Fe.....	442	420	425	340	395	389
Baltimore & Ohio*.....	692	645	620	554	441	442
Boston & Maine*.....	333	314	292	265	247	247
Buffalo, Rochester & Pittsburgh.....	707	694	710	647	635	638
Canadian Pacific.....	463	464	440	431	389	390
Central of Georgia.....	360	347	348	328	329	312
Chesapeake & Ohio.....	962	927	901	788	689	733
Chicago & Alton.....	454	479	516	455	426	421
Chicago, Burlington & Quincy.....	492	479	484	438	406	381
Chicago Great Western.....	574	512	484	434	422	345
Chicago, Milwaukee & St. Paul.....	459	454	415	355	319	322
Chicago, Rock Island & Pacific.....	380	362	356	330	320	297
Cincinnati, Hamilton & Dayton.....	649	637	631	533	455	454
Denver & Rio Grande.....	433	390	345	290	292	296
Great Northern*.....	650	663	635	601	524	518
Hocking Valley.....	1,968	1,936	1,023	883	759	674
Kansas City Southern.....	582	515	554	462	426	408
Lehigh Valley.....	644	617	621	588	564	562
Louisville & Nashville.....	347	297	295	285	275	278
Missouri Pacific.....	484	451	437	397	348	347
New York, New Haven & Hartford*.....	333	304	291	292	290	293
Norfolk & Western*.....	841	802	764	694	643	635
Pere Marquette.....	498	459	450	367	343	346
St. Louis & San Francisco.....	378	351	324	298	265	267
St. Louis Southwestern.....	345	338	349	341	320	326
Southern Railway.....	382	339	321	309	301	296
Southern Pacific.....	464	471	461	456	474	476

\* Revenue freight only.

Conditions are such that the roads will be forced to make still greater improvements in the direction of larger trainloads if they are successfully to overcome the handicaps of adverse legislation and unwise regulation and the increasing costs of both labor and material. Motive power officers should not overlook even the slightest opportunities for suggesting improvements looking toward the better use of or increased capacity of locomotives now in service, for even if the railroads could afford to buy all the new and modern power they would like to have, it would be only a small percentage of the total power now in service, and it is this power that will have to handle the bulk of the traffic for the next few years.

In the fiscal year 1915 the railroads reduced their operating expenses about \$186,000,000. About half of this reduction was in maintenance expenditures, much of which probably represented deferred maintenance. The other half of the saving was

in transportation expenses, a large part of which was probably due to better car loading and larger trainloads. An important item in securing better train-loading is the importance of power in first class condition. Locomotives cannot be consistently worked near the limit of their capacity, day in and day out, unless they are kept in prime condition. This can only be accomplished by a highly developed organization, with plenty of supervision, so that every detail may be watched closely and repairs may be anticipated by giving attention to excessive wear or slight defects before trouble develops. The mechanical department officers should never lose sight of the fact that their important function is to keep the power and equipment in such shape that the operating department may use it to the very best advantage in the way of securing more efficient and economical operation.

### The Crying Need of the Car Department

Is it not time for the railroads generally to take a more decided stand in providing for the education and training of employees in the car department? A few are doing fairly good work in this respect. Some have tried and failed; others, the great majority in fact, have done practically nothing. The responsibilities of the car department and the demands made upon it have increased greatly in recent years and promise to grow steadily. The increase in capacity of freight cars, the stronger designs made necessary by more severe service because of increased trainloads and abuse in terminal yards, the added complication of interchange rules, the necessity for giving more attention to the protection of freight, the requirements of the United States safety appliances act, and numerous other important factors, have enlarged and complicated the work of the department to such an extent that it is absolutely necessary to provide for the development and training of men successfully to carry on its work.

One apprentice instructor remarked a short time ago, "We can't keep car apprentices on our road. They leave for more attractive work elsewhere, or go into the locomotive department." The car department cannot afford to let young men leave in this way and must take decided steps to encourage ambitious boys to go into this work. In the annual report of the Division of Safety of the Interstate Commerce Commission, which appears elsewhere in this issue, two suggestions occur which are of special interest in this connection. In commenting on the necessity for increasing the braking efficiency of freight cars the report states: "Working toward this end it is gratifying to note that the carriers are educating their inspectors in a more efficient discharge of their duties and are securing men who have a better knowledge of the complicated brake systems and the problems in maintaining them." Again, later in the report, the statement is made that, "several of the railroads have general traveling inspectors who go from one inspection point to another consulting with the inspectors and repairmen, . . . The results of this educational method have been most gratifying, etc."

The railroads are, of course, in competition with industrial concerns in securing men, and in order to get the type of men that can make good in looking after the more important work in the car department they must meet this competition. Then, too, they must meet the task of educating and developing their own men, and doing this in such a way as to attract a good class of young men and encourage them to persevere by seeing that opportunities for advancement open before them. At the Master Car Builders' convention in 1912, M. K. Barnum, in discussing car department apprenticeship, made this statement: "I believe the apprentice should start in with the understanding between him and the management that he will be given a chance to learn the business of the entire department, and I believe that a schedule should be arranged which he can look over before he starts work and see what he is going to learn; see what opportunities he will be given. The schedule should cover everything in the car department, all the more important parts of the work from that of repairing a freight car truck, putting

in a brass, packing a box, up to such cabinet work as his skill and ability will enable him to do properly." If Mr. Barnum's advice was followed it would do much to attract young men to the service.

Those who have read carefully the contributions to the car inspectors' competition, which have been printed in the last few issues of this paper, must realize the importance of doing more to train men to meet fully the requirements of this exacting position. Even the Master Car Builders' Association is weak in outlining the requirements for a car inspector in its recommended practice. The practical experience which such a man must have is dismissed in two short sentences: "One year at oiling cars. Two years at car repairing." A man who can successfully hold such a position ought to spend at least as much time and intelligent effort in studying and training for it as does a machinist apprentice on a road having a first-class modern apprenticeship system. The Master Car Builders' Association ought immediately to take some steps to use its influence in remedying the deplorable conditions which now exist in the lack of attention to this important subject.

### NEW BOOKS

*General Foremen's Association Proceedings.* Edited by William Hall, secretary of the association. 269 pages. 91 illustrations. 6 in. by 9 in. Bound in paper. Published by the association, William Hall, secretary, Winona, Minn.

This book is the official report of the eleventh annual convention of the International Railway General Foremen's Association, which was held at the Hotel Sherman, Chicago, Ill., July 13 to 16, 1915. It contains the following papers, with the accompanying discussions as presented at the meeting: Valves and Valve Gearing; Rods, Tires, Wheels, etc.; Shop Efficiency; Roundhouse Efficiency and Oxy-Acetylene Welding. The paper on Valves and Valve Gearing is one of the most complete ever presented to the association, which, with the very thorough discussion that was given the subject, occupies over 100 pages in the proceedings.

*Laboratory Test of a Consolidation Locomotive.* By E. C. Schmidt, J. M. Snodgrass and R. D. Keller. 130 pages. 57 illustrations. 6 in. by 9 in. Bound in paper. Published by the University of Illinois, Urbana. Price 65 cents.

This book is published as Bulletin No. 82 of the Engineering Experimental Station of the University of Illinois, and presents the results of a series of laboratory locomotive tests, which constitute the first work of the recently established locomotive testing laboratory of the University of Illinois. The tests were made on a typical consolidation locomotive loaned to the University of Illinois by the Illinois Central. Since this is the first series of tests conducted in the new laboratory, the bulletin includes a description of the laboratory equipment and the methods of testing employed.

The locomotive was first tested in the condition in which it was received from service. It was then subjected to certain repairs, and again fully tested. The main purpose of the tests was to determine the general performance of the locomotive and the performance of its boiler and engines after the repairs were made and when the locomotive was in excellent condition. The secondary purpose was to study the effect of some of these repairs upon the locomotive's performance. The maximum amount of dry coal fired per hour was 11,127 lb. or 224.5 lb. per square foot of grate per hour. The maximum equivalent evaporation per hour was 57,954 lb. or 17.65 lb. per square foot of heating surface per hour. The University of Illinois equipment makes possible the collection of all stack cinders and the information relative to cinder losses which is presented shows these losses to have ranged from 3 to 16 per cent of the weight of the dry coal fired for what might be considered ordinary service conditions and to have amounted to 27.4 per cent of the weight of the dry coal fired during one test under extreme conditions of firing and draft.

## COMMUNICATIONS

### KINGAN-RIPKEN VALVE GEAR DEVICE

TO THE EDITOR:

DETROIT, Mich.

I have read with interest the description of the Kingan-Ripken valve gear in the August issue of your paper. While the advantages of a sharp admission are well known, it would seem from a little consideration that they were attained at the expense of the distribution in back gear; or, to be more precise, while the action in forward gear is to accelerate the admission, in back gear it is correspondingly retarded. This I proved several years ago by layouts and a wood model which I think I still have.

To what extent the action in back gear would interfere with its use would depend on the class of service it was used in; if in main line passenger work, it would seem to be at its best, as there is comparatively little work in back gear and that mostly to and from the roundhouse.

WINTHROP GATES.

MINNEAPOLIS, Minn.

TO THE EDITOR:

Mr. Gates is right in stating that the increased efficiency due to the Kingan-Ripken main rod attachment is attained in the forward gear at the expense of the back gear. It has been and is a common practice to sacrifice the back for the forward gear in practically all gears applicable to locomotives.

As about 99 per cent of the earnings of all locomotives outside of switch engines are attained with the engine in the forward gear, it would appear that any device that tends to increase the earning power of the modern high priced locomotive to the extent that our device has is a very desirable thing to have on a locomotive.

This is attained without any additional parts or complications on a style of gears which, because of reliability and easy maintenance, are very desirable for railway locomotive service, yet do not give the efficient distribution of steam needed in the large engines of today.

While it is true that the back gear is sacrificed for the forward, any engine equipped with our device is still capable of backing a train to the extent necessary in road service. This has been proven in the larger number of engines equipped. We do not recommend the device for switch engines.

KINGAN-RIPKEN.

### AN OFFICE KINK

BURNSIDE SHOPS, CHICAGO.

TO THE EDITOR:

Shop kinks are numerous, but office kinks are somewhat scarce. In this office we have a scheme which may be of some value to others, and can easily be explained.

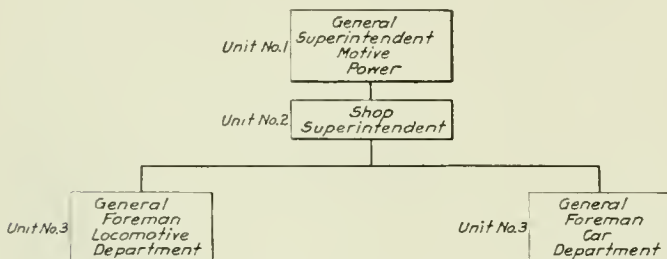

Unit 1 writes a letter to No. 2, raising a question. Unit 2 must of necessity question Units No. 3 to get the necessary information. Unit 3 investigates and reports to No. 2, who in turn gives the information to No. 1. In other words, there is a continuous repetition going on.

Our idea is for Unit 3 to address reply to No. 1, sending it to No. 2 for signature; and Unit 2 permits the letter, if correct, to go to No. 1. A carbon copy of No. 3's letter is forwarded to No. 2 for file protection.

We find that this relieves not only the work of stenographers in office of No. 2, but saves considerable time for those dictating and handling mail in No. 2's office. This system has worked out with good results, and I thought possibly it would be of interest to others.

A. J. GIBNEY,

Chief Clerk to Shop Superintendent.

### FLAT WHEELS

NEW YORK, N. Y.

TO THE EDITOR:

Below is a copy of a letter that a leading American railroad sent out to trainmen and section foremen with reference to flat wheels:

TRAINMEN AND SECTION FOREMEN:—

We are giving you below information as to the hammer blow from flat spots on car wheels. During the past three winters we have had considerable to say on flat spots, and we believe that after reading the following article, you will readily see why we have felt so much anxiety as to dangers arising from this cause.

#### THE IMPACT OF FLAT SPOTS ON CAR WHEELS

The impact resulting from flat spots on railroad wheels under different loads and at different speeds is being studied at a western university, by means of an instrument that records the force of the blow photographically. In these tests, which cover flat spots of various lengths, it has been found that a wheel with a flat spot three inches long strikes a blow of 104,000 lb. with the car going at sixteen miles an hour and carrying a load of 20,000 lb. Under similar conditions a flat spot one and one-half inches long produces a blow of 20,000 lb., and a flat spot two inches long a blow of 25,000 lb.

I presume the letter had the desired effect in that it bewildered the trainmen and foremen into the idea that our universities do wonderful work, and there is something profound in the mathematics of impact. One section foreman, for instance, exclaimed, "My! my! my! 104,000 lb.!" after reading the letter.

Just to learn how he understood the letter I asked him what a blow of 104,000 lb. meant. He started to explain with a 10-pound spike maul. He started a track spike into a tie, tapping it gently at first with "blows of 10 pounds" each, at first, and then increasing his swing in the usual way he drove it home. After finishing the job he scratched his head dubiously and agreed that it "didn't look quite right." His last blows were surely heavier than the first, he asserted.

So, after the demonstration, and after a few moments of thought, this foreman no longer understood what a "blow of 104,000 pounds" is.

As for myself, I have studied engineering, mechanics, physics, etc., somewhat, and have even gone so far as to attempt teaching engineering subjects. Yet I, a college graduate, do not understand the letter.

Perhaps a blow of one pound means "the impact resulting from the fall of a one-pound weight through a height of one foot," or one inch, or something like that. If so, should it not have been explained to the trainmen and foremen?

N. G. NEAR.

### A PLEA FOR THE DRAFTSMAN

WASHINGTON, D. C.

TO THE EDITOR:

I have read with much interest the numerous letters on the status of railroad clerks that have recently been published in the Railway Age Gazette. I should like to say a word concerning a class of men whose condition at present seems to me to be fully as unsatisfactory as that of the clerks. I refer to the draftsmen in the mechanical department.

The whole force in a drawing room is to a great extent side-tracked, so far as advancement to the higher positions on the road is concerned, but that is no reason why those in charge of a drawing room should not try to make the work interesting and attractive for the men under them. Any work of this kind is bound to be more or less monotonous, and the fact

that it demands close attention and extreme accuracy makes it tiresome, even for those long accustomed to it. Usually the chief draftsman takes the attitude that the men under him are not worth bothering with, for he knows that they are not usually of the timber from which officers are made; but granting that this is true in most cases, it is no reason for "rubbing it in," instead of giving the men some much-needed encouragement, and telling them once in a while that their work is in many ways one of the most important in their department.

Be sure that the chief draftsman takes an interest in the work of the men under him. Let him work with the men, so to speak, and decide what class of work each man is best fitted to perform. Some men are not as good as others at laying out new work, some are better at a quick job requiring but little accuracy, while still others are good at working out intricate details. Above all things let the men remember that the drawings are the plans for which a real, concrete piece of machinery is to be constructed. Teach them to think in terms of the finished product, not in terms of the drawing board.

If the plans for a new locomotive are gotten up in the office, when the new engines arrive in the yard, make it a part of the duty of the men who worked on those drawings to go down and see how the thing looks when finished. It will take them off the board for a short time, but it will be money back for the company in the end. The men will keep in touch with the actual railroad end of the business, and feel themselves a part of the whole system, a feeling which comes more naturally to the men on the road than to those whose time is spent in the office. I think if once a month one of the men could be sent off for a week to inspect some piece of work on the road it would do a lot towards making a more contented, wide-awake and efficient drafting force.

HUGH G. BOUTELL.

VALUE OF ATTRACTIVE SHOP GROUNDS

MACON, Ga.

TO THE EDITOR:

We try to keep the shop premises at Macon neat and attractive, as illustrated by the photographs which show some of the parks and flower gardens. The grounds are kept in this condition with but very little expense, only one cheap laborer being



Grounds in Front of the Master Mechanic's Office

assigned to this particular work. Foremen of the different departments take great interest in their flowers, each department having its own garden.

One of the photographs shows the grounds in front of the

master mechanic's office; another the park at the north end of the erecting shop, where all employees of locomotive department pass to and from work; and the third a flower garden on the east side of the smith shop.

There are a number of other equally attractive spots, which are not shown. All the spare ground is sodded and kept well



Park at North End of Erecting Shop

trimmed. We also have a greenhouse built of scrap material from old buildings, where the plants are kept through the winter, new plants rooted, and seed sown for early plants.

The absence of these parks and flower gardens would invite the accumulation of rubbish, scrap piles, and other eyesores around the shop grounds. Shop premises kept up in good, attractive condition make the employees better satisfied, resulting in better service.

While the shop grounds are being beautified and kept in a neat condition, we should not lose sight of the fact that it is



Flower Garden at East Side of Smith Shop

just as important, or more so, to keep a clean shop where the men can carry on their work without being crowded or climbing over piles of junk. We give the inside of the shops just as much attention as the grounds; in fact, we give the whole premises our careful attention.

C. L. DICKERT,

Assistant Master Mechanic, Central of Georgia.

TESTING FOR FLASHPOINTS.—Flashpoint may be found in a simple manner by heating a few ounces of oil over a gas flame and trying a lighted match over the surface of the oil until a wave of flame is seen to flash across its surface. The temperature of the oil when this occurs is called its flashpoint. Oils whose specific gravities are below 0.85 generally have flashpoints below 60 deg. F., while those of which the specific gravities exceed 0.85 usually have higher flashpoints.—*Power.*

# SOUTHERN RAILWAY DYNAMOMETER CAR

Latest Development in Dynamometer Car Design;  
200,000 Lb. Capacity. Seventeen Records Obtained

The Southern Railway has in service two dynamometer cars, each having a registering capacity of 200,000 lb. draw-bar pull and 800,000 lb. buffing force. The body of the cars were built by the Lenoir Car Works and all of the dynamometer equipment was furnished and installed by the Burr Company, Champaign, Ill.

## CONSTRUCTION OF CAR

The cars are 50 ft. long by 8 ft. 10 in. wide inside, the dynamometer room at one end of the car being 15 ft. 2 in. long. The rest of the car is divided into compartments for housing the testing crew, there being three lower and one upper berth, an office with a sofa berth, a room for the porter and a kitchen equipped with a range, refrigerator, etc. The car is heated with hot water from a Baker heater. Rolling side doors are provided at both sides of the car in the dynamometer room, a small door, 4 ft. high is provided in the kitchen end, and a high door is provided on the dynamometer end. A special observation window, as shown in the illustrations, is placed in each side of the car. This window projects 7 in. beyond the side of the car so

bolsters. The distance between the webs is 13 in. and the depth is 2 ft. 3 $\frac{5}{8}$  in. at the center and 12 $\frac{5}{8}$  in. at the ends. It extends from the end sill at the kitchen end to the body bolster at the

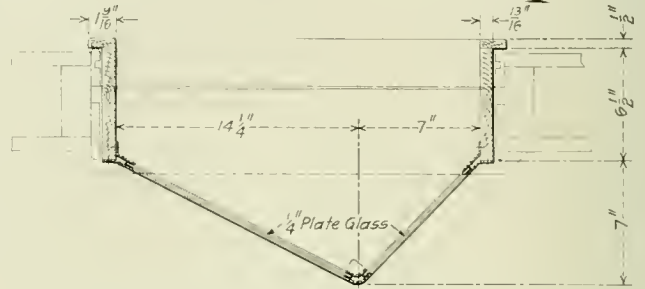

Horizontal Section Through the Observation Window

dynamometer end of the car, the dynamometer rigging being installed between the bolster and the end sill. It is made with a 3 $\frac{1}{2}$ -in. by 3 $\frac{1}{2}$ -in. by  $\frac{1}{2}$ -in. angle at the outside top of a  $\frac{3}{8}$ -in. web plate and an angle of the same size at each side of the

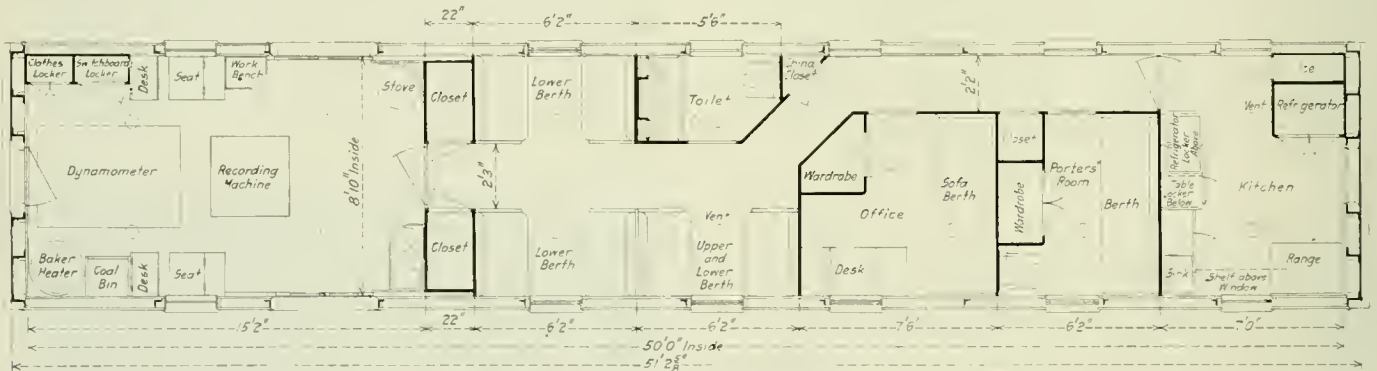

Floor Plan Showing the Interior Arrangement of the Dynamometer Car

that the observer may readily see the approaching landmarks. Directly below this window is the mile-post light box set into the car at such an angle that the light may be thrown sufficiently

bottom. It is covered with a  $\frac{3}{8}$ -in. top cover plate 2 ft. 2 in. wide, extending the full length of the girder. Two intermediate sills of 7-in., 19.75-lb. channels extend between the cross mem-

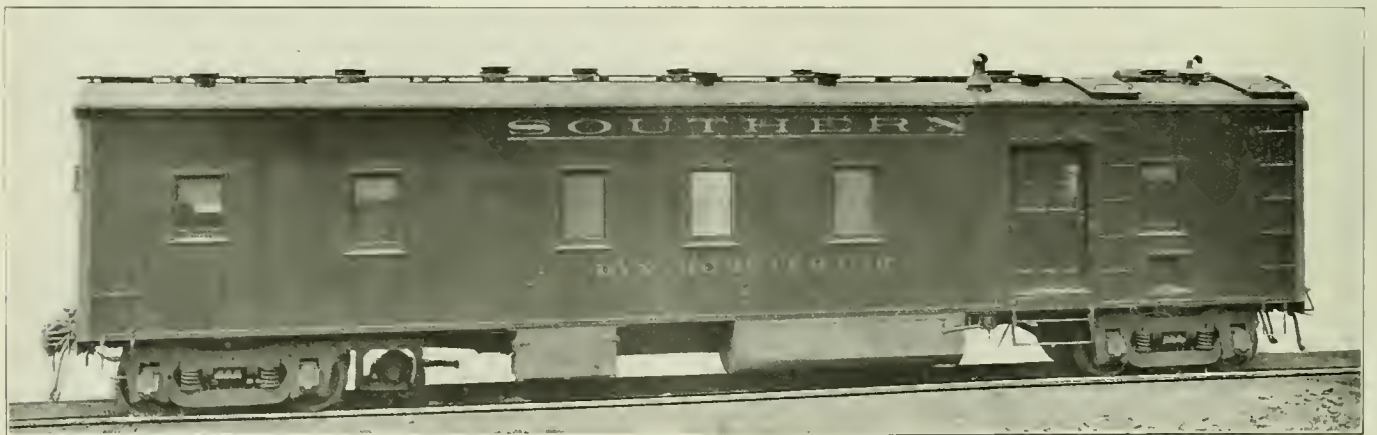

Dynamometer Car for the Southern Railway

far ahead for the observer to discern the landmarks as they are approached in the dark.

The under frame is of the built-up type, being made of structural steel shapes. The center sill is a box girder of the fish-belly type with bottom plates only at the cross-bearers and

bers of the underframe for the full length of the car. At the dynamometer end 13-in., 32-lb. channels located 18 $\frac{1}{2}$  in. each side of the center of the car extend between the end sill and the body bolster to take the place of the center sill, which terminates at the body bolster.



The side sills are 6-in., 15.6-lb. Z-bars, and extend the full length of the car. Three cross bearers are used, one at the middle of the car and one 10 ft. from the middle toward each end. They are made up of 4½-in by 3-in., 8.5-lb. T-bars, which run from the side sill to the top and bottom of the center sill, a

from the end sill 9 ft. 3 in. for the full width of the car, and immediately back of it is another plate of the same material, 4 ft. 9 in. long. This provides a substantial base for the recording table. The end sills are 13-in., 32-lb. channels.

The framing is made principally of steel shapes, 2½-in. by 2½-in. by ¼-in., angles being used for the side posts and diagonal braces and 6-in., 15.6-lb. Z-bars for the corner and end posts. The side plates are 3-in. by 3-in. by ⅜-in. angles, and the end plates are 4-in. by 3-in. by ⅜-in. angles. The carlines are made up of two 2-in. by ⅜-in. bar iron straps, between which is bolted a strip of wood 2½ in. by 1¼ in. to which is nailed the purlins and the car ceiling. The straps are flanged and riveted to the side plates. The flooring consists of a layer of 1⅛-in. and a layer of ¾-in. boards, between which is placed a layer of ⅛-in. felt paper.

DYNAMOMETER TRANSMISSION

The dynamometer mechanism is driven from the rear axle of the leading truck, to which is keyed a 36-tooth gear. This drives another gear of the same size which runs on a splined jack shaft, the entire mechanism being enclosed and running in an oil bath. By shifting this gear in and out of mesh with the axle gear, the dynamometer mechanism is thrown in and out of action. A worm on the jack shaft engages with a worm wheel which drives the main shaft, the shaft being fitted with universal and slip joints to accommodate the movement of the

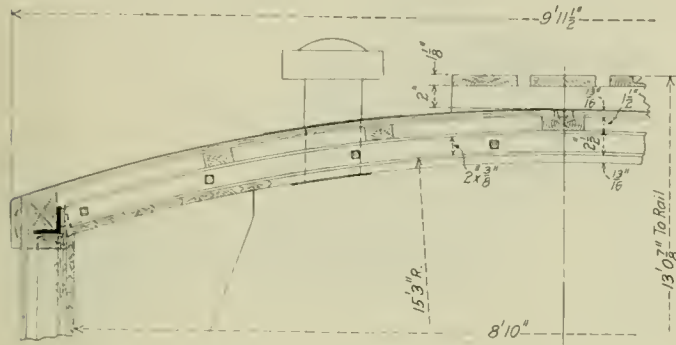

Details of the Roof Construction

5/16-in. web and a ⅜-in. top cover plate, 15 in. wide at the center, which extends from side sill to side sill. A bottom cover plate of the same material extends part way up the bottom T-bars. The webs of the cross bearers are fastened to the web of the center sills by one 6-in. by 6-in. by ⅜-in. angles. A 13-in.,

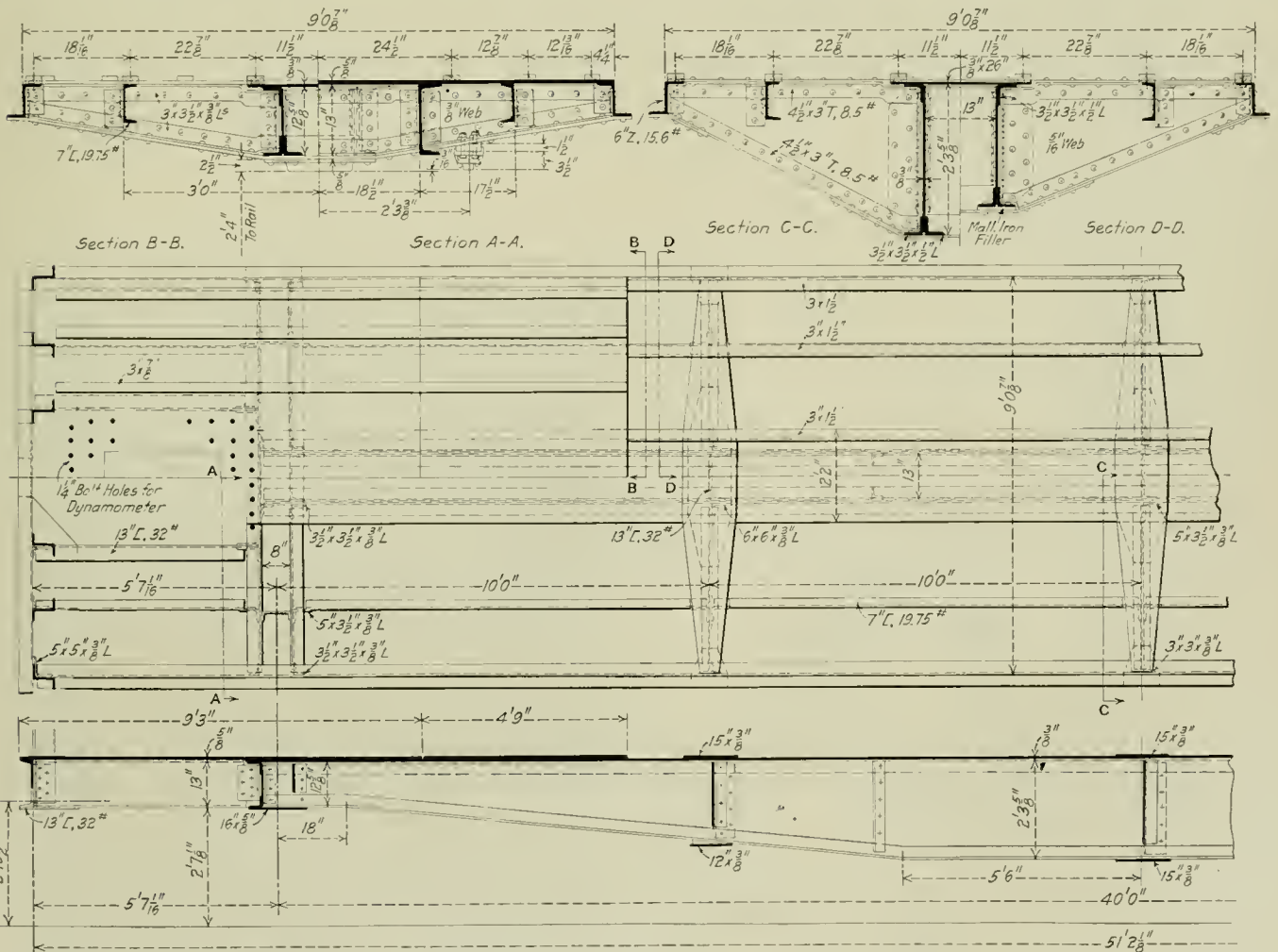

Details of the Underframe, Southern Railway Dynamometer Car

32-lb. channel is riveted between the webs of the center sill at each cross bearer.

The body holsters are of the double type, spaced 8 in. between webs. They are made up of 3-in. by 3½-in. by ⅜-in. top and bottom angles, a ⅜-in. web and a 16-in. by ⅝-in. bottom cover plate. At the dynamometer end a ⅝-in. cover plate extends back

truck. The drive is carried to the transmission case through bevel gears. A right and left spring ratchet clutch at the head of the vertical driving shaft in the transmission case provides a constant direction drive to the paper, regardless of the direction in which the car is traveling. Provision is also made for cutting out the axle drive and cutting in the motor drive, a 32-volt

$\frac{1}{4}$  h.p. motor running at 1,200 r.p.m. being used for the purpose. The transmission gears provide three speeds of paper travel, which are  $\frac{1}{16}$  in.,  $\frac{3}{4}$  in. and 1 in. per 100 ft. of car travel when driven from the axle, and  $3\frac{3}{4}$  in., 15 in. and 60 in. per minute when driven by the motor. The transmission gears are lubricated by a continuous bath of oil.

On the end of the transmission case there is provided a shaft rotating in proportion to the car travel on which is mounted a timing device giving a distance contact for each 25, 50 and 100 ft. travel of the car. The truck wheels that are used to drive the mechanism are turned to a definite circumference and are without brakes for the purpose of eliminating the wear due to the brake shoe friction. A wear of  $\frac{3}{8}$  in. on the radius is permissible, the wheels having  $\frac{3}{16}$  in. excess radius when new to maintain maximum average accuracy in service.

DYNAMOMETER

The dynamometer itself is of special interest due to the large capacity combined with the exceptionally small space it occupies in the car and the compactness of the whole arrangement. It is a new design of the diaphragm type. The coupler is rigidly connected to the bottom of the dynamometer lever, the connection being about 3 ft. back of the end sill. The dynamometer lever itself is pivoted on a  $5\frac{3}{4}$ -in. pin, which bears on six hardened steel pins inserted in the bearings to reduce the friction.

dynamometer lever is provided with knife edges, which bear on pistons on either side of the lever for recording the buffing and pulling forces. Both the pistons are suspended on knife edge

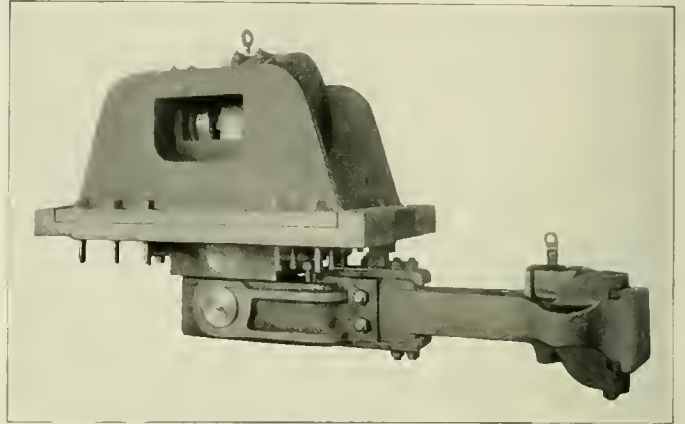

Dynamometer and Drawbar

hangers and float in the cylinders, there being a clearance of  $\frac{1}{64}$ -in. between the pistons and the cylinder walls. The buffing piston has about 160 sq. in. of surface and is designed for 2,000

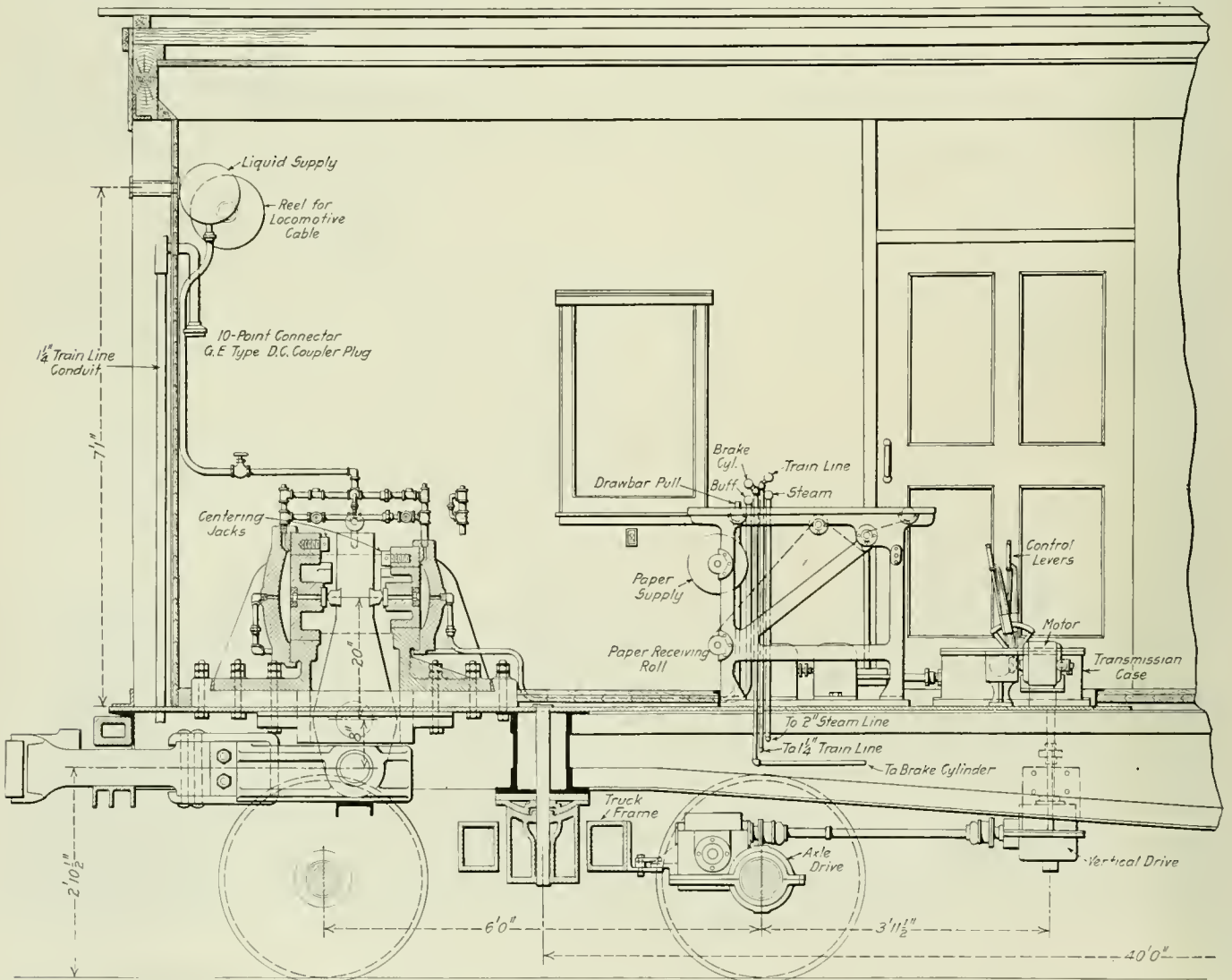

Arrangement of the Dynamometer and Recording Mechanism

The leverage ratio is 8 to 20, as indicated in the illustration. The coupler has a free up and down movement, but no sideways motion is permitted in this construction. The upper end of the

lb. per sq. in., which will give a maximum buffing capacity of 800,000 lb. The piston for recording the pull has 80 sq. in. of surface, which with a working pressure of 1,000 lb. per sq. in.,

gives a maximum pulling force of 200,000 lb. With these high fluid pressures a correspondingly increased sensitiveness is ob-

indicator. Jack screws inserted in the housing of the dynamometer are used to lock the pistons in mid-position when it is desired to replenish the supply of pressure medium in the dynamometer cylinders. The medium is carried in an overhead tank and flows to the cylinders by gravity. The base of the dynamometer itself occupies only 4 ft. 6 in. by 2 ft. 11 in. floor space.

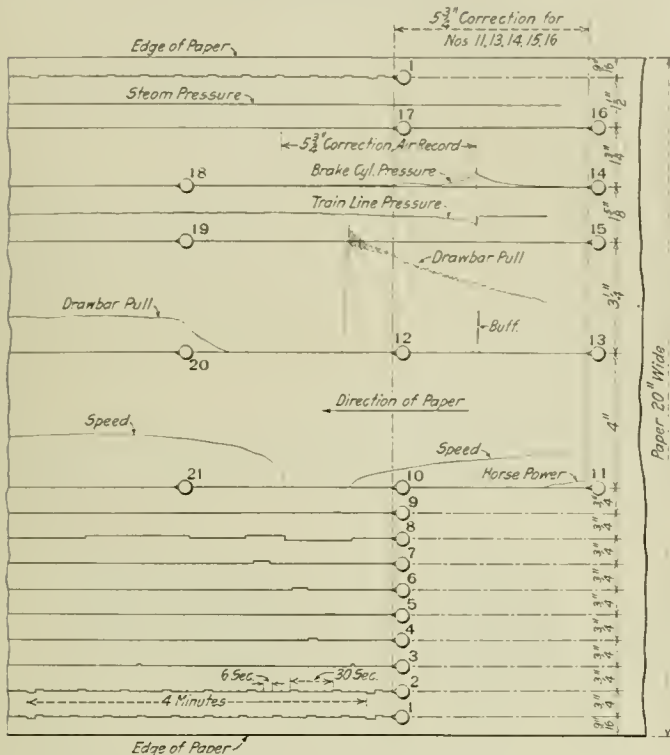

A Section of the Dynamometer Chart Showing the Arrangement of Recording Pens

tained. Inasmuch as a movement of only .006 in. is required to give the maximum record of drawbar pull, the effect of friction is very slight and the inertia effect of the heavy parts

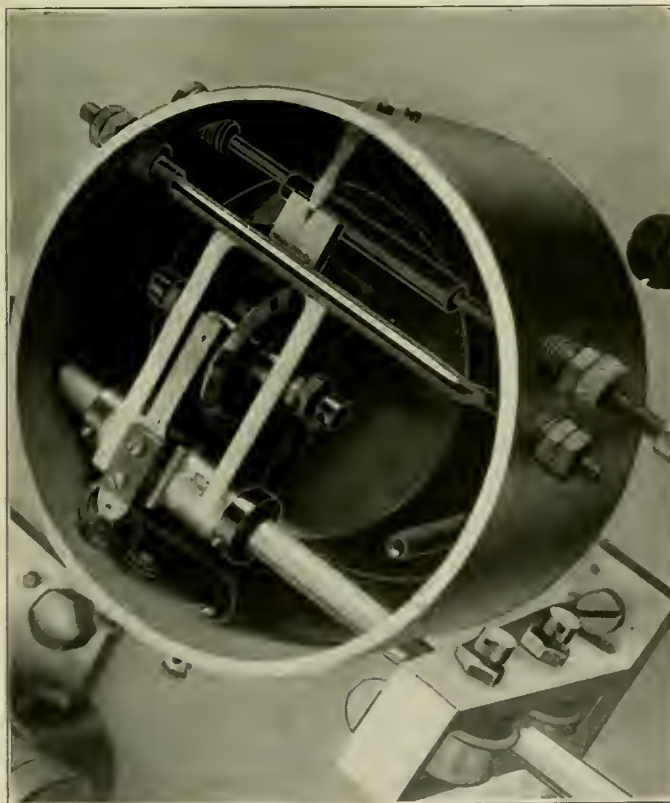

Integrator for Determining the Work Done at the Drawbar

is practically eliminated. A mixture of alcohol and glycerine is used as the pressure medium between the dynamometer and the

RECORDING TABLE

The recording table is a semi-steel structure with an aluminum top. Provision is made for the operation of 21 pens, which are distributed in three rows. The first row contains four datum pens and the second row contains the pens for registering the distance, integrator records, drawbar pull, speed, throttle position, curves, indicator cards, reverse lever position, coal fired, mile posts and the time. The last row contains the pens for steam pressure, train line pressure, brake cylinder pressure, buffing force and horsepower. A correction of 5 3/4 in. must be allowed between the second and last rows of pens. The table is designed for

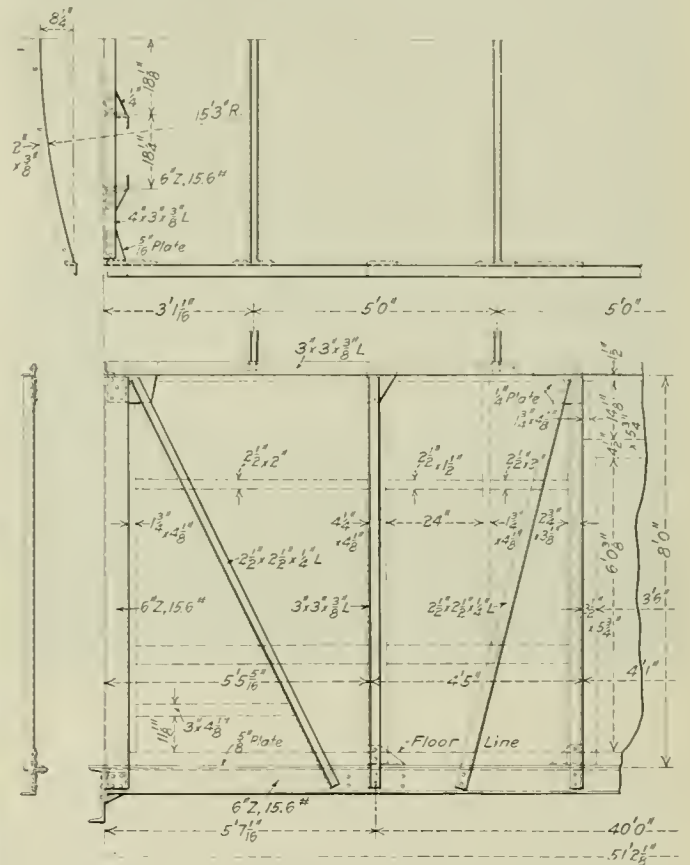

Steel Framing of the Superstructure—Southern Railway Dynamometer Car

paper 24 in. wide, although 20-in. paper is used. On the table is mounted the integrator, which gives a continuous record of the area under the drawbar pull curve. This instrument is of simple construction and is accurate to within a fraction of one per cent. It consists essentially of a flat steel disc with a carefully polished surface, which is revolved at a speed proportional to the paper speed, the ratio being 1 1/2 in. of paper travel per revolution of the disc. A small hardened steel wheel similar to the ordinary type of integrator wheel is carried in a light frame and rests normally at the center of the disc, being moved from its central position by the action of the drawbar pull indicator. Thus, for any distance traveled the number of revolutions of the integrator wheel will be proportional to the product of the paper travel equivalent to the given distance and the average value of the ordinates of the drawbar pull curve. One revolution of the integrator wheel is equivalent to 6 sq. in. of area under the drawbar pull curve and each revolution is recorded on the paper.

The horsepower computer is also located on the top of the

table at the right, just in front of the speed gage. It is a mechanical multiplying machine operating on the triangulation principle, multiplying the ordinate of the drawbar pull curve by a speed value obtained from the Boyer speed recorder. The product, or the horsepower, is recorded on the chart. Ordinary electro-magnets are used for actuating the pens where only offsets are desired. Outside spring Tabor indicators are used for recording the buffing force, train line pressure, brake cylinder pressure and locomotive steam pressure. A special indicator is used to record the drawbar pull, which has a maximum travel of 6 in. Its cylinder has a sectional area of 1/2 in. and the plunger

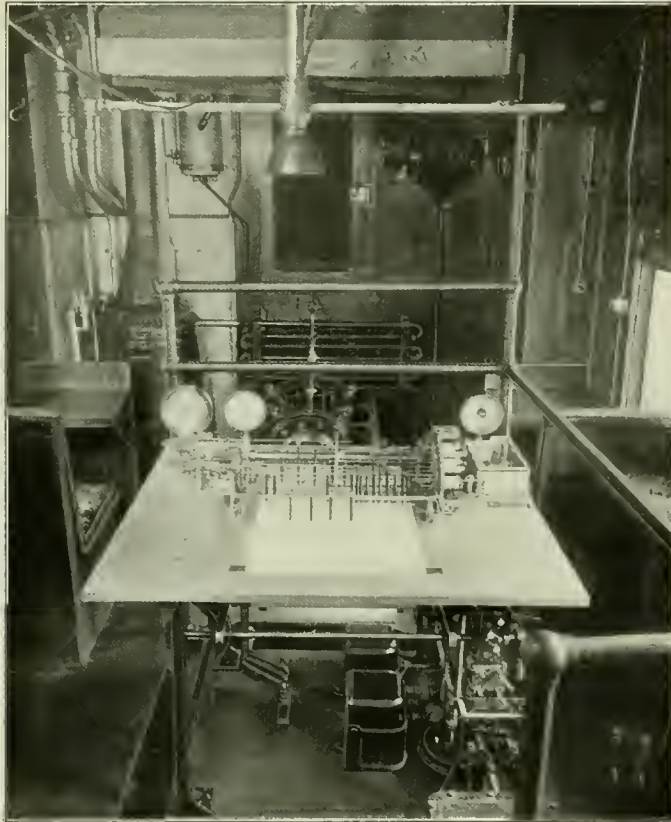

Interior of the Southern Railway Dynamometer Car, Dynamometer End

has a travel of 1 in. All electrical circuits are controlled by the table operator and are located directly beneath the top of the dynamometer table at the right hand of the operator. Adjacent to the table is the transmission case with its two controlling levers mentioned above, which also may be conveniently reached by the operator. The recording table is equipped with suitable mechanical drives for the accurate driving of the paper.

The electrical circuits that are operated from the locomotive are contained in a cable which runs from the dynamometer car over the tender to the locomotive. This cable contains 10 different circuits. When not in use it is wound on a reel just inside the car. The car is provided with an axle lighting system.

MEANING OF "HEAVY" STEAM GAGE OR SAFETY VALVE.—In each case the terms are to be used according to the purpose of the appliance. When a steam gage indicates more pressure than it should, it is said to be "heavy," as a short method of imparting information that its indications are higher or "heavier" than the actual pressure. The operation or the adjustment of a safety valve is said to be "heavy" or "too heavy" if the pressure at which it blows is too high or too heavy for its purpose, or if the valve does not blow until the pressure of the boiler is greater than the pressure for which the valve is supposed to be loaded.—*Power.*

## DESIGN OF HOLLOW CRANK PINS

BY C. W. BENICA

With the tendency toward larger and more powerful locomotives the crank pin diameters have assumed proportions that a few years ago would have been suitable for axles. The weight of the crank pin and its portion of the counterbalance have thus been very greatly increased.

Two methods are available to reduce this weight—the use of eccentric main crank pins\* whereby the radius of the side rod throw may be reduced without effecting the piston stroke; and the use of hollow crank pins. The former method is unsatisfactory for a number of reasons. The eccentricity of the crank pin cannot be made very great without increasing the diameter of the pin at the face of the hub. But perhaps the most serious objection from a mechanical standpoint is the increased stress put upon the pins and rods, due to the decreased moment arm of the forces acting on the side rods.

The hollow crank pin seems to be the most effective means of reducing the crank pin weight. A possible reduction of from 26 per cent to 30 per cent of the usual weight can be made by

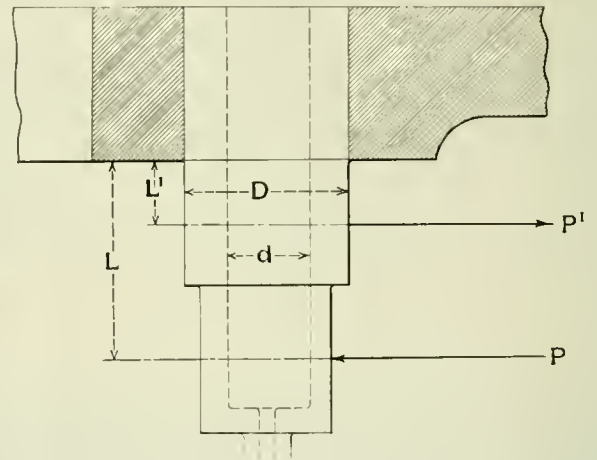

careful use of this method. The required diameters can be found by considering the pin as a beam fixed at one end and loaded at the other and applying the cantilever formula:

$$M = \frac{S I}{C} \dots \dots \dots (1)$$

in which:

- M = the bending moment
- S = the allowable fiber stress
- I = moment of inertia of a hollow circular section =  $\frac{D^4 - d^4}{64}$
- C = distance of neutral axis to extremities of section =  $\frac{D}{2}$
- D = outside diameter of hollow section
- d = inside diameter of hollow section

The bending moment should be taken with the engine on the front dead center because the piston pressure is then greatest and the pin receives no support from the side rod. The bending moment can be represented by:

$$M = P \times L,$$

in which:

- P = piston load = area of piston  $\times$  boiler pressure,
- L = length of pin from hub face to center line of main rod,

Substituting the values given above for  $\frac{I}{C}$  equation (1) becomes

$$P L = \frac{\pi}{32} \left( \frac{L^4 - d^4}{D} \right) S \dots \dots \dots (2)$$

$$D = \frac{(D^4 - d^4) \pi S}{32 P L} \dots \dots \dots (3)$$

At this point it is necessary to assume a definite ratio of ex-

\*The use of this pin in British practice was referred to in H. A. F. Campbell's article on "Reciprocating and Revolving Parts," page 442, September, 1915.

ternal to internal diameter. Judgment and practice seem to indicate a ratio of  $\frac{D}{d} = 2$  as being about right and this ratio is used in deriving the following formula. Substituting for  $d$  its value in terms of  $D$ , formula (3) becomes,

$$D = \left( D^4 - \frac{D^4}{2} \right)^{1/3} \frac{P L}{32 \pi s}$$

Using the sub letter  $m$  to indicate that the values are for the main crank pin, and reducing, the following formulae are obtained:

$$D_m = 8 \sqrt[3]{\frac{P L}{15 \pi s}} \dots \dots \dots (4)$$

$$d_m = \frac{D_m}{2} \dots \dots \dots (5)$$

These formulae may be applied to crank pins other than the main by substituting for  $P$  and  $L$  their moment  $P'xL'$ , (see illustration), where

$$P' = \frac{W d}{3.5 s}$$

in which:

- $W$  = the total weight on all drivers obtaining their motion through the crank pin considered; this is to allow for the maximum force on the crank pin; i. e., when the side of the engine is on a dead center and the other side on the quarter;
- $d$  = diameter of drivers in inches,
- $s$  = stroke in inches,
- $3.5$  = a constant determined by experiment.

Then, using the sub-letter  $o$  to indicate crank pins other than main

$$D_o = 8 \sqrt[3]{\frac{P' L'}{15 \pi s}} \dots \dots \dots (6)$$

$$d = \frac{D_o}{2} \dots \dots \dots (7)$$

Another method of calculating the diameter of a hollow crank pin is to first calculate the diameter of a solid pin and then make a hollow pin of equal strength. In this case any ratio can be applied much easier than in (3). Let

$$D_s = \text{diameter of a solid pin} = \sqrt[3]{\frac{32 P L}{\pi s}}$$

$D_1$  = outside diameter of a hollow pin of the same strength,

$d_1$  = inside diameter of the hollow pin =  $\frac{D_1}{2}$ ,

Then since the two pins are to be of equal strength,

$$D_s^3 = \frac{D_1^3 - d_1^3}{D_1} = D_1^3 \left( 1 - \frac{d_1^3}{D_1^3} \right) \dots \dots \dots (8)$$

Substituting for  $D_1$  the assumed ratio  $x$ , and solving for the outside diameter,

$$D_1 = D_s \sqrt[3]{\frac{1}{1 - x^3}} \dots \dots \dots (9)$$

The radical  $\sqrt[3]{\frac{1}{1 - x^3}}$  is constant for any given value of  $x$  and the values of the two diameters may be expressed by the formulae

$$D_1 = D_s \times C \dots \dots \dots (10)$$

$$d_1 = D_1 \times x \dots \dots \dots (11)$$

Values of  $C$  are very readily determined for any value of  $x$ . For instance, with a value of  $x = \frac{1}{2}$ ,  $C$  has a value of 1.0275 and for  $x = \frac{1}{3}$ ,  $C$  has a value of 1.013, thus making it very simple

to determine the required diameters of a hollow pin when the diameter of the equivalent solid pin is known.

## ROAD TESTS OF EXHAUST NOZZLES

BY E. S. BARNUM

Within the last year locomotive exhaust nozzles of special shapes have come in for considerable attention. Just why they have not received more attention in the past it is hard to understand, unless it is because the average motive power officer dismisses the statement that a locomotive is not steaming with a "make her steam" to the roundhouse foreman. "Make her steam" to a roundhouse foreman usually means but one thing, to reduce the size of the nozzle until the locomotive steams.

While test plant data may be available to show that nozzles

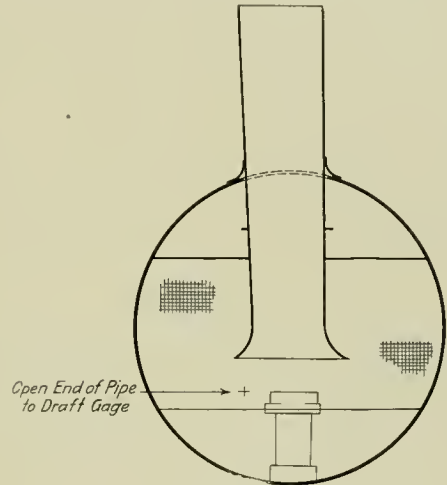

Fig. 1

of special shapes will increase the rate of evaporation and the amount of water evaporated per pound of coal, railroad officers generally are loath to accept such data unless tests made in actual road service indicate the same results. Road tests which would give reliable data as to the coal and water rate, would require the use of a comparatively large corps of trained observers.

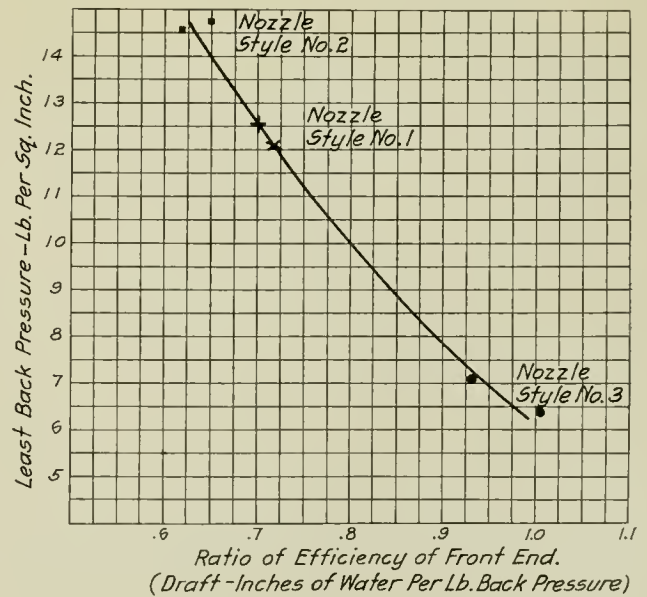

Fig. 2

Possibly this has contributed to the slow development not only of the nozzle but of the whole front end as well. Such exhaustive tests are not necessary, however, to obtain a comparison of the work actually being done by different styles of nozzles.

The exhaust does work in creating draft at the expense of work done in the cylinders. The greater the work done by the exhaust the higher the back pressure. The back pressure can

be measured accurately with indicators and the amount of draft created can be determined with the ordinary draft gage, the open end of which should be located at the height of the nozzle and about 6 in. away, as indicated in Fig. 1. By reducing the results thus secured to draft in inches of water per pound of back pressure, we obtain a ratio which may be considered as an expression of the efficiency of any exhaust nozzle. The data to be secured and the method of comparing the performance of different nozzles is shown in the table, the data there shown being taken from an actual test. The curve in Fig. 2 is obtained by plotting the draft per lb. of back pressure against the least back pressure.

TEST DATA FOR DETERMINING EFFICIENCY OF EXHAUST NOZZLES			
Nozzle style	Least back pressure A	Draft B	Ratio of efficiency $\frac{B}{A}$
1	12.5	8.75	.7
1	12.05	8.67	.72
2	14.55	9.02	.62
2	14.7	9.55	.65
3	7.1	6.6	.93
3	6.4	6.4	1.0

All of above nozzles have an opening equivalent to the opening of a 5½" round nozzle.

It is a simple matter to secure readings at the same speed, position of reverse lever, throttle and boiler pressure. The thickness of the fire has an appreciable effect on the draft secured in the front end and as it is next to impossible to measure accurately the depth of fire on a locomotive while working, the tests should be conducted with an assigned fireman who is known to do steady, consistent work with a level fire. Before beginning the tests preliminary readings should be taken to determine that the vacuum in the ashpan is not more than .1 to .2 in. of water. If it runs higher than this, additional openings should be made till this figure is reached. Readings of such a small amount are hard to get on the road due to the oscillation of the locomotive. After trying out a number of different methods, the writer finally hit upon the scheme of

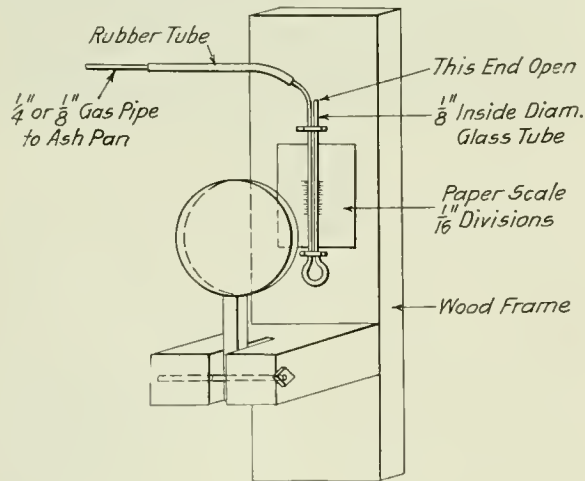

Fig. 3

using a gage of small diameter glass tubing, and making the readings with a magnifying glass as shown in Fig. 3. The capillary action of the water in the small tube seems to have a steadying effect on the column, making it possible to get more accurate readings.

Any test work on nozzles, irrespective of its purpose, would not be complete without data relative to the action of the exhaust in the stack. The nozzle tip acts in much the same way as the throat of a venturi tube, and the exhaust column and stack, or lift pipe, constitute the conical approaches to the throat. A change in either might necessitate a change in either, or both, of the other two, if we are to get the highest efficiency. It is

essential that the exhaust elements be in line. This is a shop proposition, and the stack and exhaust column should be lined up before any road work is attempted. To get the maximum draft out of the exhaust it should hit the stack about three or four inches from the top. As shown at A in Fig. 5 a stack which is too small would cause the exhaust to hit too far down, while one that is too large would allow the exhaust to pass out without filling it, thereby losing some of the effective vacuum, as shown at B.

The plane at which the exhaust is hitting the stack can be

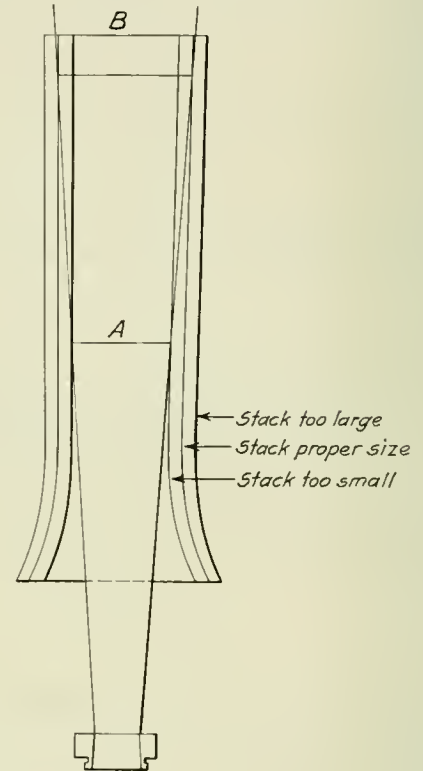

Fig. 4

located with a U-shaped piece of pipe of small diameter having a pipe cap on one end with a 1/8-in. drilled hole, and the other end connected to a mercury filled draft gage by means of a piece of rubber tubing. By moving the pipe up and down the inside of the stack at several different locations the point of neither pressure nor vacuum can be located. Only a few of these readings are necessary for each change in the front end. A few readings of each style of nozzle should be taken across the top of the stack\* to show how the pressure is equalized. These readings should be taken parallel, and at right angles to the track, using a run of small sized pipe with a 1/8-in. drilled hole in the center. Suitable hooks, or guides, should be provided around the outside of the stack. Nothing connected with the test apparatus should be permanently located in the stack as it will have an effect on the steaming of the locomotive.

In the last proceedings of the American Railway Master Mechanics' Association, one of the committees reports that a number of roads have experimented with special types of nozzles, and "claim a considerable saving in coal as a result," and that "the subject presents a fertile field for future investigation." The writer knows of a case where a road crew made their locomotive steam by wedging a 14-in. monkey wrench across the top of the stack. They were not correcting the defect but were effecting a cure by means of a "counter-irritant." Such incidents point to the need for a more detailed investigation, not only of the nozzle but of the whole front end.

\*For more detailed description of methods employed in determining stack conditions see an article by the same author on page 454 of the September, 1915, issue of the *Railway Age Gazette, Mechanical Edition.*

# LOCOMOTIVE WATER AND COAL CONSUMPTION

## Methods for Calculating Water and Coal Consumption Under Different Operating Conditions

BY HAROLD A. HUSTON  
Rock Island Lines, Chicago, Ill.

*Water Consumption.*—Water consumption varies greatly with the conditions of operation. The amount of water used per unit of time when a boiler is working to its limit is constant for different speeds if these speeds are above the maximum speed where boiler pressure can be maintained with full cut-off. If these speeds are below the maximum speed where boiler pressure can be maintained with full cut-off, then the water consumption varies directly with the speed. Reference to Fig. 1 will make clear these statements. For example, let us see how Fig. 1 is developed. This figure represents the water and coal consumption for a locomotive, a few of whose dimensions are as follows:

Diameter of drivers.....	63 in.
Cylinder diameter.....	24 in.
Cylinder stroke.....	30 in.
Boiler pressure.....	200 lb.
Heating surface.....	3,614 sq. ft.
Volume of each cylinder.....	7.83 cu. ft.

It is reasonable to expect 11.5 lb. of equivalent evaporation as a maximum for each square foot of heating surface per

cent, the steam consumption when the maximum tractive effort is based on cylinder power, is calculated as follows: From steam tables, the weight of one cubic foot of steam in the cylinders at  $200 \times 0.95$  (or 190 lb.) is 0.447 lb. The weight of one cubic foot of water at a temperature of 384 deg. F., corresponding to 190 lb. steam pressure, is 54.19 lb. By assumption, one pound of the mixture of steam and water contains 0.80 lb.

of steam and 0.20 lb. of water, therefore  $\frac{0.80}{4.47} + \frac{0.20}{54.19}$  gives a

total volume of 1.7907 cu. ft. for one pound of the mixture. The number of pounds of the mixture required for one revolution of the drivers is:

$$\frac{7.83 \times 4 \times .88}{1.7907} = 15.28 \text{ lb.}$$

No allowance is made for clearance, as it is assumed that the pressure due to compression is equal to the initial pressure at cut-off. From the calculations, it is evident that the volume at cut-off represents the quantity of the mixture of steam and water used in one stroke. Now, the maximum train speed at full cut-off (88 per cent) where full boiler pressure can be maintained is:

$$\frac{578}{15.28} = 37.8 \text{ revolutions per minute.}$$

This maximum train speed converted into miles per hour gives 7.09.

At one-half, or at  $\frac{1}{x}$  of the maximum speed at full cut-off as at 3.55 m. p. h. or at  $\frac{7.09}{x}$  m. p. h., the steam consumption

would be one-half, or  $\frac{1}{x}$ , as great; or, in other words, the steam consumption from zero speed to that speed where the cylinders can develop maximum tractive effort without exhausting the boiler, varies as a straight line, as is shown by the line *OA* in Fig. 1. For other speeds, it is obvious that the maximum cut-off for a particular speed will require a steam consumption equal to the amount that the boiler can generate without a decrease in boiler pressure. This is represented by the line *AB* in Fig. 1. For ordinary conditions of operation, it is unusual for a locomotive to work under maximum power conditions for long periods of time; generally about 30 minutes can be taken as a maximum limit of time except in mountainous regions. For this reason, it becomes necessary to develop a process for determining the steam consumption for such periods of average operation.

If the effect of changes in the rate of evaporation and in the quality of the steam in the cylinder at different cut-offs is neglected, and the advantage gained by permitting a given amount of steam to work expansively, as at short cut-offs, is also neglected, it seems reasonable to expect the tractive effort to be a reliable measure of the capacity to which the boiler is worked. Under these assumptions, we may consider that the ratio of the required tender drawbar pull to the available tender drawbar pull for any speed and any train in question, gives the percentage of maximum capacity to which the boiler is worked. Expressed as a fractional ratio, we have:

$$\frac{\text{Required T.D.B.P.}}{\text{Available T.D.B.P.}} = \text{Approximate percentage of maximum capacity to which the boiler is worked.}$$

As shown by Fig. 1, the steam consumption has been based

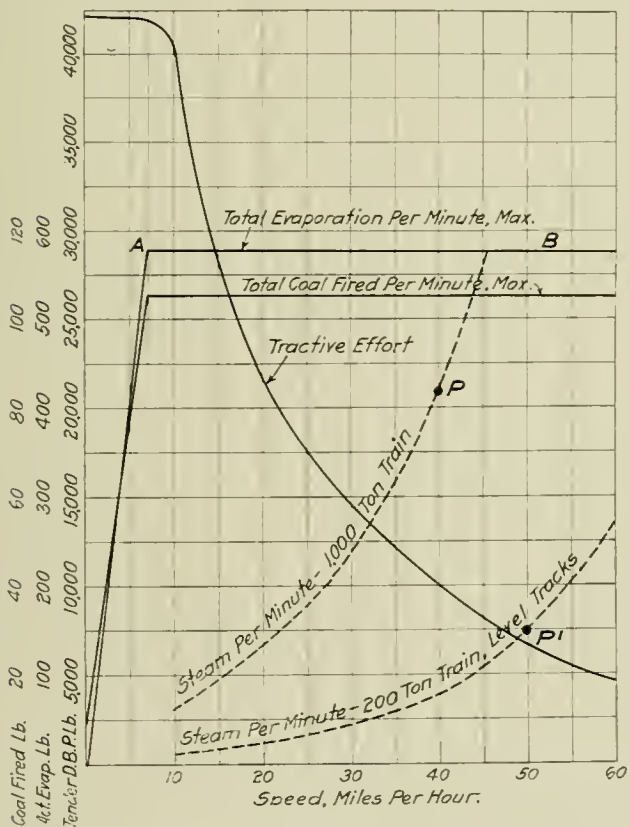

Fig. 1

hour for this locomotive. At this rate, the maximum amount of actual steam generated and used per minute without a drop in the boiler pressure is:

$$\frac{11.5 \times 3614}{1.2 \times 60} = 578 \text{ lb.}$$

The temperature of the feed water is taken at 60 deg. F. and the equivalent evaporation is corrected, by dividing by 1.2, to give the actual evaporation at 200 lb. pressure. For one revolution of the drivers, assuming that the valve gear is so designed that a maximum cut-off of 88 per cent is obtained and that the quality of the steam in the cylinders at cut-off is 80 per

upon a unit of time, viz., the minute. For the problem in hand, it is convenient to take the time required for the locomotive to exert power on a train from the speed-time curves as shown in Fig. 2. It is obvious that the maximum steam consumption per minute is constant when the boiler is working to its capacity or when the engine is running at its maximum speed and the capacity of the boiler is taxed. At low speeds the engine may be working to a maximum, but the boiler may be working much below its capacity. In such instances where acceleration is taking place, the steam consumption is based on the average speed during that period of acceleration. In other words, if

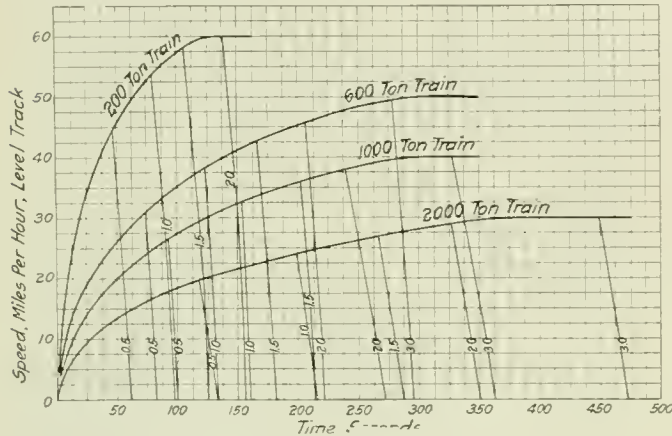

Fig. 2—Speed—Time Curves

$S$  is the value of the steam consumption at the speed  $I'$  where the boiler is just able to supply the steam at maximum cut-off, and since it is obvious that the steam consumption at zero speed is zero, then the average amount of steam used during

$$\text{acceleration to the speed } I' \text{ is } \frac{S}{2}$$

Accordingly, to find the steam consumption for any locomotive at the head of a train for maximum conditions of operation, first take the steam consumption during the time the locomotive has its maximum tractive effort determined by the cylinders and add to this the steam consumption during the period that the maximum tractive effort is determined by the

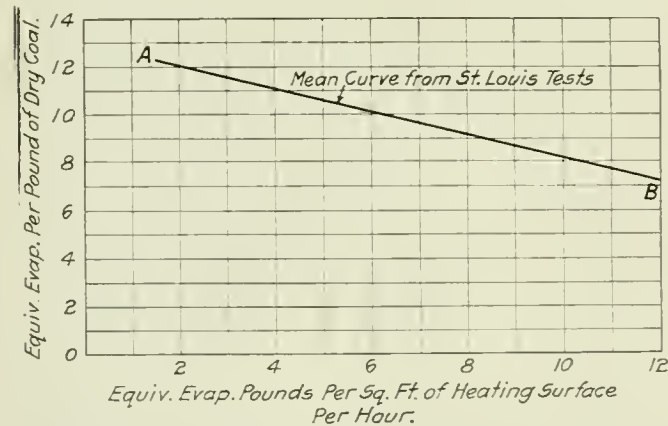

Fig. 3

evaporative power of the boiler. For those conditions of operation where the boiler and engine are not worked to a maximum, the determination of the steam consumption for lesser rates of power is here accomplished by the use of the following equation:

$$E \frac{R}{A} = S$$

Where:  $E$  = Maximum evaporation per minute, (pounds).  
 $R$  = Required tender drawbar pull, (pounds).  
 $A$  = Available tender drawbar pull, (pounds).  
 and  $S$  = Steam consumption in lb. per minute at a constant speed for any particular locomotive and train in question.

For example, by reference to Table I, which shows in tabular

form the accelerations for the locomotive under consideration we find that the 200-ton passenger train and the 1,000-ton freight train can be hauled on level track to speeds which are in excess of the limits assigned by the conditions of the problem. Therefore, to haul these trains on level track at speeds within the limits imposed by the problem, both the engine and boiler are required to work at a lesser power. For instance, since the locomotive is what is termed a "small driver" locomotive, its speed is limited to 60 m. p. h. The required tender drawbar pull for the 200-ton train at a constant speed of 50 m. p. h. is 1,680 lb., as shown in Column 9 of the table. At this speed the locomotive is capable of developing an available tender drawbar pull of 6,740 lb., as shown in Column 3, which necessitates a maximum actual steam consumption of 578 lb. per minute, as has been heretofore determined. Now, the expression for steam consumption at this low power is:

$$578 \times \frac{1,680}{6,740} = 145 \text{ lb. per minute.}$$

This determines the point  $P'$  shown in Fig. 1, on the steam consumption curve for the locomotive and the 200-ton train while running at a constant speed of 50 m.p.h. on level tangent track. All other points on this curve are determined in the same manner.

The steam consumption curve for this locomotive and the 1,000-ton freight train for low rates of power is determined by the same method cited above. But with this problem the

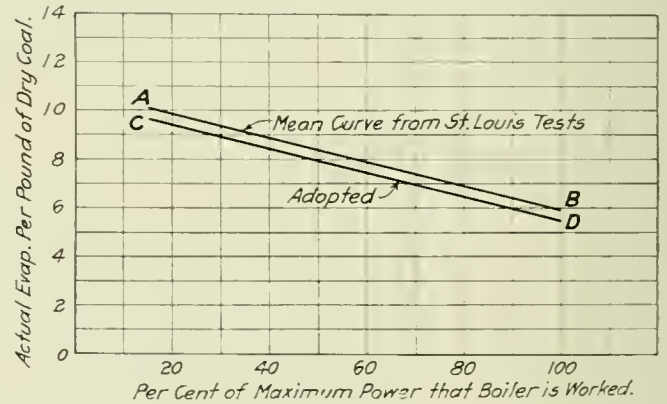

Fig. 4

speed limit imposed is 40 m.p.h., therefore by Table I, Column 12, it is evident that the tender drawbar pull available for acceleration is sufficient to develop a speed of 45 m.p.h. with maximum boiler conditions. The required tender drawbar pull for this 1,000-ton train for a constant speed of 40 m.p.h. is 7,300 lb., as shown in Column 9. At this speed the locomotive is capable of developing an available tender drawbar pull of 10,090 lb., as shown in Column 3, which necessitates a maximum steam consumption of 578 lb. per minute, as has been heretofore determined. Now, the expression for steam consumption at this low power is:

$$578 \times \frac{7,300}{10,090} = 418 \text{ lb. per minute.}$$

This determines the point  $P$  shown in Fig. 1, on the steam consumption curve for this locomotive, and the 1,000-ton train while running at a constant speed of 40 m.p.h. on level tangent track. All other points on this curve are determined in the same manner. Thus we have a simple means of determining the water consumption at any power and speed for any locomotive and train.

**Coal Consumption.**—For estimating the amount of coal consumed under maximum conditions of operation it is necessary to fix the maximum quantity of coal that can be economically fired in a boiler of specified proportions containing a given amount of heating surface. For the case under consideration, the maximum amount of coal consumed per square foot of heating surface is 1.75 lb. And according to the tractive effort formula, a rate of 11.5 lb. of equivalent evaporation may be



expected for maximum conditions. This means that an evaporation of 6.6 lb. from and at 212 deg. per pound of coal, or an actual evaporation of 5.5 lb. per pound of coal is to be expected for maximum conditions of operation. These figures appear rather low when compared with test plant data, but if compared to the results from road tests, it is seen that the figures here presented are representative of actual road conditions.

For lower power conditions, the amount of coal consumed depends on the amount of steam used, although not in a direct proportion. During operation at such rates of power, the amount of work performed per pound of steam is greater than at higher rates of power. Then again the amount of steam generated per pound of coal is greater at low power than at high power. Locomotive fuel consumption as affected by these two combinations of conditions, is not accurately determinate. An attempt at the solution of the problem is made by neglecting the first condition, and by correcting for the second. As in the method outlined for determining water consumption, the ratio of the required tender drawbar pull to the available tender drawbar pull for a locomotive at the head of a certain train when running at a selected constant speed, gives the percentage of maximum power to which the boiler is worked. As stated before, the coal consumption is known for maximum power conditions; it only remains to correct for the law governing the increase in water evaporation per pound of coal for different rates of boiler power.

If we let the rate of evaporation per square foot of heating surface per hour represent the rate of power to which a boiler is worked, then the curve in Fig. 3 represents the variation in the evaporation per pound of coal for different rates of power. The curve is based on a grade of coal equivalent to the coal used in determining the tractive effort of the locomotive in

working under less than maximum power conditions, first determine the percentage of maximum power that the boiler is worked, and then divide the water consumption as previously determined, by the evaporation per pound of coal as given by curve *CD* in Fig. 4.

### FUEL ECONOMY\*

BY H. C. WOODBRIDGE

Assistant to General Manager, Buffalo, Rochester & Pittsburgh

As matters of particular import to fuel economy, I would suggest boiler and engine design, construction, maintenance and operation, upon which many excellent treatises have been prepared. But to be more specific, let me recommend super-heating apparatus, brick arches, combustion chambers, draft regulation, feed water heaters, condensers, re-heaters, stokers; the selection, preparation and storage of fuel, including both powdered and liquid combustibles; valve gears and setting to insure proper steam distribution; the elimination of unnecessary fires, particularly in locomotives not required for service within twenty-four hours; fuel records and accounting; smoke consumers and precipitators; lubrication—which item brings to mind a condition frequently encountered in departmental organization, which is inimical and in some instances disastrous to fuel economy. I refer to the unfortunate practice, prevalent to a large degree in railroad accounting, which removes from the mechanical department ledger all traces of expense for locomotive fuel, and at the same time so conspicuously records the expenses for lubricants on that ledger that the important and direct relation to economy in fuel is lost sight of, and even proper analysis of repair costs is overshadowed and therefore neglected. Study also the requirements necessary to avoid

TABLE I

Speed M.P.H. 1	Available tender Drawbar pull—lb.			Available drawbar pull per ton of train—in lb.			Resistance per ton of train—lb.			Drawbar pull available for acceleration—lb. per ton		
	1 per cent up grade 2	Level 3	1 per cent down grade 4	1 per cent up grade 5	Level 6	1 per cent down grade 7	1 per cent up grade 8	Level 9	1 per cent down grade 10	1 per cent up grade 11	Level 12	1 per cent down grade 13
200 TON TRAIN												
0	.....	.....	.....	.....	.....	.....	.....	.....	.....	.....	.....	.....
5	38430	42110	45790	192.2	210.6	229.0	23.72	3.72	-16.28	168.5	206.9	245.3
10	36805	40485	44165	184.0	202.4	220.8	24.00	4.00	-16.00	160.0	198.4	236.8
15	25680	29360	33040	128.4	146.8	165.2	24.34	4.34	-15.66	103.1	142.5	181.9
20	18390	22070	25750	92.0	110.4	128.8	24.74	4.74	-15.26	67.3	105.7	144.1
25	13980	17660	21340	69.6	88.3	106.7	25.20	5.20	-14.80	44.7	83.1	121.5
30	11000	14680	18360	55.0	73.4	91.8	25.72	5.72	-14.28	29.3	67.7	106.1
35	8320	12000	15680	41.6	60.0	78.4	26.28	6.28	-13.72	15.3	53.7	92.1
40	6410	10090	13770	37.1	50.5	68.9	26.94	6.94	-13.06	5.2	43.6	82.0
45	4550	8230	11910	22.8	41.2	59.6	27.60	7.60	-12.40	.....	33.6	72.0
50	3060	6740	10420	15.3	33.7	52.1	28.40	8.40	-11.60	.....	25.3	63.7
55	1800	5480	9160	9.0	27.4	45.8	29.28	9.28	-10.72	.....	18.1	56.8
60	620	4300	7980	3.1	21.5	39.9	30.10	10.10	-9.90	.....	11.4	49.8
1000 TON TRAIN												
0	.....	.....	.....	.....	.....	.....	.....	.....	.....	.....	.....	.....
5	38430	42110	45790	38.4	42.1	45.8	24.01	4.01	-15.99	14.4	38.1	61.8
10	36805	40485	44165	36.8	40.5	44.2	24.27	4.27	-15.73	12.5	36.2	59.9
15	25680	29360	33040	25.7	29.4	33.0	24.60	4.60	-15.40	1.1	24.8	48.4
20	18390	22070	25750	18.4	22.1	25.8	25.00	5.00	-15.00	.....	17.1	40.8
25	13980	17660	21340	14.0	17.7	21.3	25.47	5.47	-14.53	.....	12.2	35.8
30	11000	14680	18360	11.0	14.7	18.4	26.00	6.00	-14.00	.....	8.7	32.4
35	8320	12000	15680	8.3	12.0	15.7	26.62	6.62	-13.38	.....	5.4	29.1
40	6410	10090	13770	6.4	10.1	13.8	27.30	7.30	-12.70	.....	2.8	26.5

question. As stated before, the maximum rate of equivalent evaporation per square foot of heating surface is 11.5 lb., therefore the curve *AB* shown in Fig. 3 can be plotted to new scales and given the form shown as curve *AB* in Fig. 4. Now, the problem under consideration has shown that at maximum rates of boiler operation, the actual evaporation per pound of coal is 5.5 lb., therefore the point *D* has been taken so that its abscissa equals 100 per cent, and the corresponding ordinate is 5.5, and the curve *CD* has been drawn through the point *D* parallel to *AB*; or, in other words, the curve *CD* is drawn to have the same slope as *AB*. The curve *CD* then represents the actual evaporation per pound of coal for the various rates of power that the boiler is worked.

To get the pounds of coal consumed when the boiler is

delays to trains, which are responsible for great waste of fuel, and finally, the selection, training and supervision of men, upon which three subdivisions I solicit your indulgence for a moment.

#### SELECTION OF FIREMEN

One writer says, "Only too often a fireman is chosen for his muscle, low wages and ability to endure high temperatures existing in the fire rooms, and little or no attention is paid his intelligence." In both Germany and Great Britain schools are maintained for the instruction of firemen, and much emphasis is placed on the skill of the individual in handling the fire. They find that it is better to employ a competent man at a rea-

\* From a paper presented at the January, 1916, meeting of the Railway Club of Pittsburgh.

sonable wage than it is to employ an incompetent man at a low wage. In this way they avoid the necessity for additional supervision, numerous incidental annoyances, the consumption of a larger quantity of coal and the production of unnecessary black smoke.

In 1907 three hundred firemen had been especially trained by the officers of the Hamburg Society for Prevention of Smoke. A report of this society shows thermal efficiency with the regular but untrained firemen 66.6 per cent, and thermal efficiency of the same plant with trained firemen 72.7 per cent. These statements, while referring particularly to stationary practice, indicate methods thoroughly applicable to locomotive operation. This is proven by the results of experiments conducted in the laboratory of the Pennsylvania Railroad at Altoona under the direction of Professor Goss. These tests showed a boiler efficiency of 73.2 per cent when the locomotive was fired by experienced men and 59.7 per cent when fired by inexperienced men.

#### LACK OF SUPERVISION.

We must have efficient supervision, for we all need inspiration, assistance and some discipline lest we become plodders with low aim and little interest; and I would not hazard an estimate of the losses caused by supervision by men whose vision and actions are confined by subnormal limitations of the brain and heart.

To obtain, even approximately, the possible economies, co-operation and interest on the part of every man in the ranks, as well as the officers, is essential. Low grade supervision is responsible for much of the indifference and vicious antagonism encountered in our men; and selfishness, conceit and lack of foresight and education are responsible for most serious delays. Where would our vaunted supremacy be if everyone had carefully obeyed the old adage, "Be not the first by whom the new is tried"? And worse still, imagine the transportation inefficiency from which we would now be suffering had not a few men of foresight and strength fairly jammed the superheater and the stoker and the modern locomotive down the throats of the majority of men in responsible official positions on our railroads. I sat in the Master Mechanics' Association meetings back in 1906-7, when the forceful and eloquent pleading of H. H. Vaughn in favor of superheating our locomotives fell principally on barren ground. The development and application of superheating apparatus has reduced, by at least one-fifth, the fuel consumed in service; and this apparatus, designed primarily to reduce fuel consumption, has simplified the problem of increasing the earning power per old unit. By materially increasing the possible boiler capacity within the limits of size and weight to which our designs must conform, it has, together with the stoker, made possible the modern power plant on wheels, and thus averted more than one crisis.

#### THE CRYING NEED.

There is another fuel, upon the conservatism or best use of which our progress and perhaps the very existence of our country may depend. I appeal to you to promote development which will insure against waste of this, the most valuable fuel that ever was, or ever will be mined. I refer to the elements which burn in the mind and heart of the progressive man. There has been a tremendous and cruel waste of this fuel in the superexhaustion enforced on many such men by self-satisfied and narrow men in authority, who have strangled incentive and initiative in their associates until cultures of "What's the use" germs have developed everywhere.

The manager or superintendent who fails to make the most of the corrective and creative power in his associates—which include the supply men—and in his subordinates, has failed to take advantage of his greatest opportunities.

If you encourage initiative in others and aid in the development of their thoughts, you will strike at the heart of the disease which at times cripples our fuel as well as other economy efforts. I commend to you a paragraph from one of

the best prayers I ever heard: "O God! Keep us from narrow pride in outgrown ways, blind eyes that will not see the good of change, impatient judgments of the methods and experiments of others."

### THE PRINCIPLES OF SMOKE FORMATION

In that part of its report devoted to its investigations of locomotive smoke, the Chicago Association of Commerce Committee of Investigation on Smoke Abatement and Electrification of Railway Terminals, outlined in some detail the principles underlying the formation of smoke. It was pointed out that the factors affecting smoke formation are the combustible, the supporter of combustion (air), and the temperature at which combustion proceeds.

The combustible elements in coal may be grouped into two divisions, namely, volatile matter and fixed carbon, the proportion of these varying greatly in the various kinds of coal. As a supporter of combustion the air may be regarded as being composed of oxygen and nitrogen. Theoretically there must be 2.67 lb. of oxygen, or 11.55 lb. of air, for every pound of carbon. In ordinary furnace operation, however, it is necessary to provide for more than the theoretical amount of air. Regarding the third factor in combustion, namely, the temperature, it may be stated that every combustible has its critical temperature, below which it will not unite with oxygen.

The combustion of bituminous coal proceeds by stages. There is at first a period occurring at comparatively low temperature, about 500 deg. F., of so-called "destructive distillation," in which a disruption in the substance of the fuel takes place, the volatile portion being thrown out and separated from the non-volatile. The second stage of combustion involves the decomposition of the hydro-carbon, the volatile portion, and the burning of its gaseous constituents at a temperature of about 800 deg. F. This stage is a critical one, as regards smoke formation. If too little air is admitted to the furnace, or if the amount admitted is not properly distributed a portion of the carbon in the fuel is carried away unburned and visible smoke results. The third stage of combustion proceeds at a temperature which is nominally about 1,600 deg. F. It is during this stage that the non-volatile portion of the fuel, consisting chiefly of carbon, is burned. The third stage of combustion may easily be made smokeless, but if the supply of air be deficient incomplete combustion and visible smoke may result.

An important aspect of combustion relates to the economical use of fuel, which is a matter that cannot be completely separated from that of smoke prevention. As a result of elaborate tests made in recent years, it has been determined that under certain conditions resulting in apparent smokelessness there may be an escape of unburned combustible gases with a consequent loss of heat units while conditions which may utilize fuel value to a fuller extent result in a slight degree of smokiness. Careful laboratory tests have demonstrated that the amount of heat lost in black smoke is comparatively insignificant, one investigator reporting that under the worst possible conditions of combustion, if the smoke were collected there would be a saving of only 14.7 lb. from a ton of coal, provided all the smoke were burned again.

ADVANTAGE OF STEAM TURBINES USING HIGH VACUUM.—In case of a reciprocating engine working condensing, without unduly curtailing the initial volume of steam admitted to the cylinder the number of expansions is limited, and with a high vacuum the walls of the cylinder are alternately exposed to the temperature of the expanding steam and the cooling effect of vacuum, in consequence of which more than about 26 in. of vacuum counteracts the advantage of reduction of the back-pressure by higher vacuum. In the operation of a turbine there is a continuous flow of steam, and the higher the vacuum the greater the kinetic energy developed by the steam.—*Power.*

# THE DANGER OF OVERDOING THINGS

The "Old Man" Hands Out Some Good Advice  
But Falls Down in Making a Personal Application

BY HARVEY DE WITT WOLCOMB

It was a cold, blustering, genuine "rip-snorter" winter's day and railroading at the busy terminal of the X. Y. & Z., at Greenfield, was being handled under the most disagreeable and trying conditions. The failure of any one man, or a slight error of judgment, would have resulted in tying up the place so tight that business would have come to a standstill; therefore, every man was on the jump to help keep things moving. Even the old division master mechanic, Jack Hawthorne, was right on the job every minute, and in the past few days of the cold snap had put in so many long strenuous hours that his usual rough temper was even rougher.

The "Old Man," as every one called him, was one of those old time master mechanics who had learned the business of railroading from long years of bitter experience and it was thoroughly understood that a situation he could not straighten out was beyond the ability of any human being to handle. While he had a good organization and one that could be trusted in difficult conditions, it seemed as if it was the "Old Man's" second nature to have to get out on the ground and take charge of affairs himself and, I believe, that he was never happier than when buried up to his neck in some hard proposition.

While "thawing out his shins" that morning in the round house foreman's office, the message boy handed him a bunch of telegrams, the very first of which made him "snort" and angrily exclaim: "Here is another engine failure charged up against us simply because that fool yardmaster overloaded the 3,900 during this kind of weather. It is all very well to figure out on paper how many cars to leave off a train for every 10 deg. drop in the temperature, but let me tell you that when that 10 deg. drop is helped along with this heavy snow and blustering wind, you had better leave off twice as many cars if you want to keep your trains moving. This 'over' stuff makes me sick, for all we hear now-a-days is 'over' something.

"It is the same old story in every department on this railroad for no matter what we try to do, some have to get over-anxious to carry out their part of the program, and it will spoil the entire project unless we stop them in time. Do you know that I have been in the railroad game so long and have seen so many failures caused by this 'over' bug-a-bear that when any one tells me things are moving along without a hitch, I get suspicious that all is not well and I had better get busy before someone overdoes his part. From bitter experience, I have learned that killing an idea or plan is not always the result of unconsciously overdoing some part, but is the result of well laid plans to make the idea appear so ridiculous that it is impossible to obtain the results expected. One of the easiest ways to make people see the folly of some out-landish order is to carry it out to the extremes, for there can be no come-back as long as you are obeying orders, yet the weak points will be brought to light in such a manner that changes will soon be in order.

PENNY WISE, POUND FOOLISH.

"When we first took up the economy idea on this railroad, I could see that our general manager was 'over' economizing and that we would have to pay for some costly experiences unless he would listen to the counsel of his subordinates. We had been working under the economy rule for a short time and I could see that it was on a fair way to be so badly overdone that it wouldn't last much longer, when the general manager had me up to headquarters for a conference on some other matters.

"After we finished our business, the talk switched over to

economy, and I tried to counsel with the G. M., but he would have none of it. He got so interested in his argument, that in order to prove his point with actual figures, he reached over to the waste paper basket and picked out an old envelope on which to do his figuring. I believe to this day he thought by using this old envelope as scratch paper he would impress on me how far he, the general manager, was practising economy. Well, say; that was the move to fit my argument, and I shot it into him for all I was worth. I showed him that at his salary, the minute he lost in picking up and straightening out that old envelope, represented more actual money value to the company than the cost of a good sized scratch pad.

"I told him that story of the ambitious shipping clerk in a large concern who was anxious for promotion, and in order to get the notice of his employers neglected his own work to go down in the shipping room and knock nails out of old boxes so that they could be used over again. He figured that his employers would see how he was economizing for them and they would reward his efforts with promotion. His efforts were noticed, but not in the way he had planned on. It was proven that even for a \$35 clerk to reclaim nails was a loss to the company and that new nails could be purchased for less than his wages would come to, so the ambitious clerk was promoted out of the back door and a new man put on his job.

"I told 'the boss' that just the other day I had read in the newspapers that our post office department had gone out of its way to commend thrifty post-masters and their assistants who had utilized their valuable time in tying together, for use a second time, pieces of string received around incoming mail. On paper this means a saving of thousands of dollars a year, but it can be carried too far, for post-masters and clerks who can afford to devote any considerable part of their time to tying together the short pieces of discarded twine are probably getting more salary than the twine is worth. It didn't take many arguments like these to bring the G. M. around to my point of view and the result is that he has seen his folly in shoving the economy idea too far, and to-day we have one of the best economy systems in the country.

HOBBIES ARE COSTLY

"As I look back over my career, I can see now where this company has lost a lot of money by over enthusiasm of its employees. One case I remember very well, for I guess I was to blame for it. There had just been a new president appointed and we were tipped off in the shop that he was on his way to make an inspection of the shop and that he was a great man for neatness around the shops. I was given charge of cleaning up the place. We had several big pits where we used to keep our pipes, so I dumped every last thing off the shop floor into these pits. What we couldn't get into the pits, I had buried outside the shop. Well after that inspection trip we couldn't find half our material and what we did find was broken or bent out of shape, so that cleanup was overdone to a queen's taste and resulted in a costly experience to the company.

"On the other hand, some one in authority may have a hobby that he honestly believes is of a great benefit to the company; if it is studied from all sides, however, it may be found unnecessary. We once had a master mechanic who was a great 'sticker' on having all tools for machines in nice racks at the different machines. Not only tool racks, but he had nice lockers for the men installed at each machine, for he claimed that a man could waste a lot of time and money by leaving his machine

to go to his locker. Well, the idea was overdone by building a lot of costly racks and lockers at each machine.

"The next master mechanic that we had had a hobby just the other way, for he claimed that all tools should be kept in the tool room and that all the lockers at the machines were in the way of the workmen and should be in a regular locker room. The result was that the matter was again overdone by taking every last tool away from the machines and placing them in the tool room, so that to some extent, the regular shop work was retarded by the men having to run to the tool room so often.

"Some fellows are like an alarm clock, for if you start them going they never get run down till they have lost all their spring. Take my roundhouse foreman, for instance. One day I told him his house was badly littered up and he ought to get busy and clean house. He got busy and over-did the job by throwing out every block and bar about the place, and now when a man wants a block or a bar he has to spend a long time to find it. We all know the importance of this kind of material when it is kept in the proper place, but it certainly makes a roundhouse look untidy when it is scattered all about.

"If our fore-sight was as good as our hind-sight we would never overdo a thing. Some fellows never seem able to see far enough ahead to realize that they are getting in trouble. When I was general foreman in this shop, I had a young mechanic working under me that was extra good. I took quite a liking to this young man and started in to coach him for a foremanship. My master mechanic told me to go slow and to be careful, but I thought I knew the young fellow better than he did, so when the chance came I appointed him to the position as erecting shop foreman. Well, do you know that that young man was a rank failure as a foreman, for being a good fast mechanic himself he thought that every one of the workmen ought to be able to do as much as he would himself.

#### DANGER OF OVERDOING.

"When I think of some of the deals that I have helped ruin by simply overdoing my duty, I feel ashamed of myself. When the company first tried out the efficiency system in this shop, we foremen didn't quite understand the workings of the system and decided that it would be to our advantage to knock it out. We put our heads together and agreed to overdo the matter to such an extent that the company would soon get sick of its bargain and drop it. You know that the success of efficiency is in the establishing of accurate records, so we started in to keep records. The job of keeping records soon got to be so enormous that we had more clerks employed than we had first class mechanics. About every 10 men had a clerk and the efficiency experts were so numerous that it seemed as if we didn't have any men at all that were really working. Well, the result was that our first attempt to establish an efficiency system was a flat failure and, as we predicted, it didn't last long.

"However, with all of the failures that I have been telling you about, you can find the same results in every day life and you don't have to limit yourself to railroad work. All things considered, I believe there are less failures in railroad work, caused by overdoing, than in the business world. Pick up a newspaper and you will read where some great athlete has failed at the final or supreme test and the reason given is that he was overtrained. Business failures occur and you can trace the trouble back to some part that was overdone, while in our railroad work it doesn't take long to find out the fellows that overdo their part before much damage occurs.

"We railroaders protect ourselves when we find some department that is 'putting it over' on us. Now this engine failure of the 3900 was the direct cause of too many cars in this kind of weather, and, believe me, I am going to put it up to the management to either have our present yardmaster use a little common sense or else put in a man that will. I don't want to see a man get the job that is just the reverse of our over-ambitious yardmaster and be too cautious, for sometimes too much caution will do as much harm as overdoing. When we

find a mechanic that is overcautious we generally find he is so slow that he doesn't accomplish anything. I can stand a mistake once in a while better than I can stand a man that doesn't do enough work to keep warm. Whatever you do, don't overdo your strength and ruin your health, for one man cannot do it all in one day.

The "Old Man" had gotten so interested in his talk that he had forgotten the stress of business and had concluded the longest talk that any of his men had ever heard him make. It was a well known fact that he preached the folly of overdoing anything, and it was one of his greatest hobbies to always caution his men to learn when enough is enough. Some of the men remarked that the "Old Man" was one of those fortunate fellows who apparently had "the eighth sense" so well developed that he always knew when "enough was enough."

The cold snap didn't let up any during the day and as business was very brisk, every one was dead tired when night came and it was time for the night force to be on duty.

The "Old Man" had kept plugging all day and if he was tired, he never let on. He seemed to be the busiest man around the plant, in fact he didn't go home to supper, but kept right on the job so as to be sure that everything was in shape to get through the night without tying-up the place.

About 11 o'clock he staggered into the roundhouse foreman's office and before assistance could reach him, sank to the floor, unconscious. First aid methods were given him and the company's doctor was sent for in a hurry. Every man around the plant loved the "Old Man," for although he had a rough manner and was very touchy, every one knew that he was true as steel and quite a crowd gathered about the office.

The doctor soon arrived and after a hasty examination remarked that it was nothing serious, but was simply a case of overdoing. It seemed as if the doctor spoke with a touch of irony, when he continued that men today didn't seem to realize when enough was enough and the people couldn't see "the other side" of things till they had overtaxed themselves till failure overtook them.

## THE QUESTION OF PROMOTION

BY F. A. WHITAKER

You hear a lot nowadays about efficiency. If I am one of the rank and file, why should I go out of my way to gain knowledge which at the time does not do me any good financially? Because by so doing I gain more knowledge; knowledge is power and more power means more money. The majority of railroads nowadays promote their own men, but do they always promote men on account of their efficiency? There is a saying: "It isn't what a man knows, it is *who* he knows that counts."

On the other hand, does promotion mean more money? Sometimes it does, sometimes it does not. Take a machinist, engineer or conductor. When these men are promoted to official positions, in the majority of cases it means anywhere from \$10 to \$20 a month less. Of course in the long run if they make good they will have a chance at the bigger jobs that pay the money.

There is also another side to this question. Take, for instance, some of the outside jobs where it is hard to keep a man on account of location and conditions. When a man holding one of these jobs is suggested for promotion, the remark is often made: "He is the only man we have been able to get that has been able to hold down that job; we had better keep him there." As a result the good job goes to another man with perhaps half the efficiency and the more efficient man stays on the old job at the low salary. By the time the outside man has been passed by a few times he gets discouraged and looks for another job on another railroad, where 10 to 1 he starts all over again. If he had stayed with his tools, his engine or his caboose in the first place and had passed up the outside job he would have been making \$10 or \$20 dollars a month more. After all, efficiency is no good to a man unless he benefits by more money. Some people take into consideration the titles that go with the jobs, but titles do not pay grocery bills.

# CAR DEPARTMENT

## STEEL ROOF FOR BOX CARS

For the purpose of utilizing the good portion of the steel sheets taken from the roof of destroyed cars, William Queenan, assistant superintendent of shops, and Charles Murphy, tinshop foreman, of the Chicago, Burlington & Quincy at Aurora, Ill., have devised a new steel roof. This roof is simple in construction, easy to make, entirely flexible and waterproof. It consists of but five parts: the roof sheets, transverse and center cover caps, eave flashings and the roof clips. The roof sheets are 24 in. by 50½ in. They are crimped on three edges to a U-shape, and flanged on the fourth to pass over the roof at the eaves. The intermediate or transverse cover caps are 47⅛ in. wide by 58¾ in. long. The long edges are crimped and have a free fit in the roof sheets. One end is flanged to pass over the eaves and the other is provided with an elongated hole through which is passed the ¾-in. carriage bolt which fastens the running board saddle to the ridge pole. The center cover caps are 17½ in. wide and 30 in. long. They are crowned at the center and crimped for part of the way on the long edges. This crimping engages with the crimping on the roof sheets. Each end of the center cover cap is provided with slots 1½ in. long, through which pass the running board saddle bolts. As shown in the drawings, the end pieces of both the transverse and center cover caps are of special construction, being flanged over the edge of the roof and held by clips. Clips are also applied to the middle of each roof sheet, at the eaves.

This roof has many desirable features; it will permit of a

sharp corners nor crevices to collect dirt and hold moisture. Air can circulate freely to all parts of the sheets, thus keeping

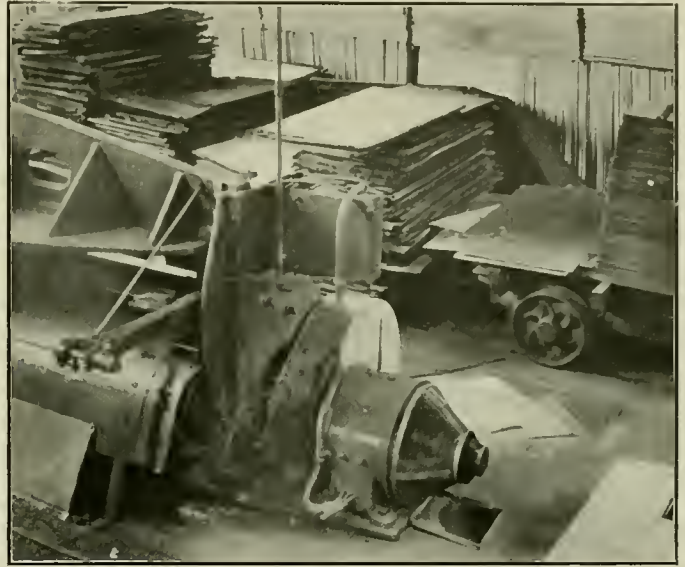

Shop Where Old Roof Sheets are Reworked

them in a dry condition. It is an economical roof to make and maintain. The sizes of the roof sheets and center cover caps

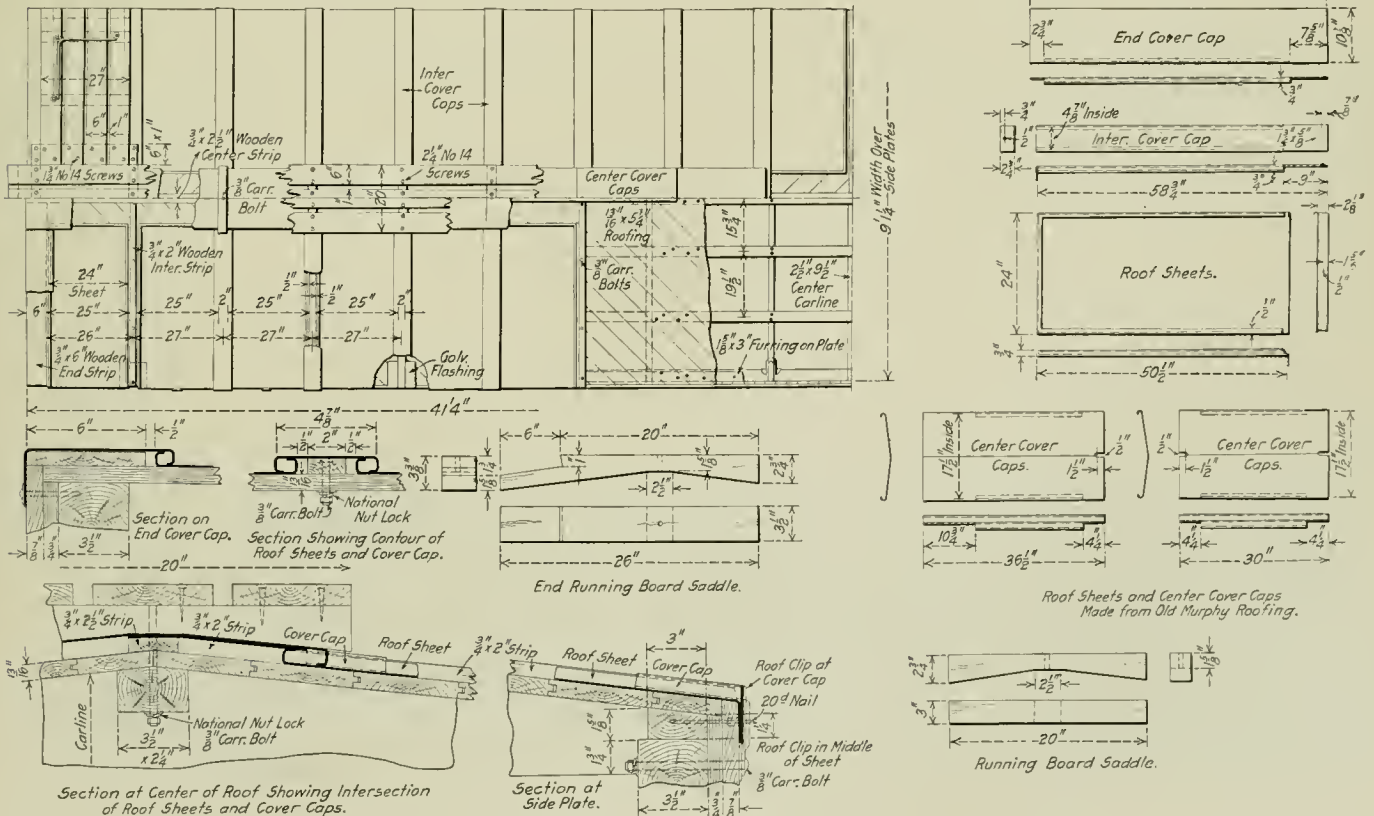

Steel Box Car Roof; Chicago, Burlington & Quincy

large amount of wearing of the car without straining the sheets nor opening up holes for water to leak through. There are no

are so chosen that old roof sheets may be cut down, reformed and used. It is necessary, however, to make the transverse

cover caps of new material. The photograph shows the interior of the shop where the old roof sheets are recut to proper dimensions.

## STEEL PASSENGER AND FREIGHT CARS

Some of the more important problems in connection with the design and operation of steel cars are touched on in the committee report on rails and equipment, which was made at the twenty-seventh annual convention of the National Association of Railroad Commissioners. The chairman of the committee is Interstate Commerce Commissioner C. C. McChord. The other members of the committee are E. J. Bean of the Missouri Commission, Frank R. Devlin of California, Everett E. Stone of Massachusetts, Paul B. Trammell of Georgia, and William R. Warner of Vermont. That part of the report referring to steel cars is as follows:

The construction of new passenger coaches is now practically confined to steel construction. Several years have elapsed since other than an occasional wooden coach has been built. The number of steel underframe cars has increased by the conversion of wooden cars. The trend in construction is toward a design which possesses sufficient strength in the sills and the lower parts of the body to resist the shocks which may be expected in cases of derailment and collisions. Strength in the sides and roof is also required in cases when the cars are overturned. Types of construction are being presented, in which trussed members are introduced into the sides to furnish the necessary strength and effect some decrease in weight over those types in which the strength is located chiefly in the sills or underframe. The ends should have sufficient strength to prevent shearing of the sides of the car, in resisting telescoping. It has been pointed out that opportunity is presented to introduce some shock absorbing feature in the construction of the vestibule, to relieve the body of shocks of collision in some degree.

The securing of the seats to the flooring is an important matter. The retardation of the speed of a train in collision and its effects on the passengers may be considered, independent of impact of the passengers with objects within the car. In order to avoid such cases of impact, the interior parts of the coach must be firmly attached to the sides or flooring and all bunching of the seats prevented. Thomas E. Brown, consulting engineer, in a communication which was quoted in the report of last year, expressed the belief that passengers, under the assumed conditions of the case as described to him, could endure, without serious injury, retardations as great as the cars themselves would successfully withstand. Mr. Brown mentioned his having personally experienced a retardation of 75 feet per second, without injury, and not much discomfort.

Provided coach construction reaches that stage in which the retardation of speed of the train is not attended with the destruction of the body of the coach and is brought to rest with the interior fittings practically intact, then interest centers on the effect of such retardation on the physical condition of the passengers. During the past year an example was presented in which the retardation reached a very high limit. The steel car which sustained this sudden arrest of speed passed through it without material injury. From a speed of 56 miles an hour, the car came to rest in about three car lengths. There were no cases of personal injury reported, which seemed to have been influenced by reason of this sudden arrest of speed. Examples of high rates of retardation, affording opportunity for acquiring such data, are not numerous, but this case furnished an instance in which the views expressed by Mr. Brown were confirmed.

Injury has been received by steel cars in which local crushing of one end was endured without injury to the opposite end of the car. Gusset plates or other means adopted to give shearing resistance above the floor line, anti-climbers and roof strength, with adequate security of the seats to the flooring, make provision for contingencies which might be expected to arise at a derailment or collision. Passengers in a sitting posture, with

some open space in front of them, would be expected to receive injury in colliding with objects within the car, which is a different phase of the problem to that of retardation alone.

Rigidity of form usually accompanies strength in constructive work, and steel cars present greater rigidity than those of wood. The inherent properties of the two materials, steel and wood, constitute an initial difference, while the connections of the parts differ so radically that a further element of rigidity enters into the fabrication of a steel over a wooden car. This rigidity of form makes it desirable to provide flexibility in the running gear. The weight of the car should be distributed as uniformly as possible on the different wheels, and diagonal corners not at times take an undue share of the load.

Concerning the durability of the structural parts of a steel cars on which its strength depends, data are not yet available. In the case of freight cars, durability of the body is largely insured by protecting exposed plates against rust. Thin sheet metal sides are soon destroyed by oxidation if unprotected by paint.

Cars which are rendered unserviceable from local injuries present examples in which the damage has been in part received in the yard. Tests were made by Prof. L. E. Endsley on the impact between freight cars in switching service, the results of which were reported to the Master Car Builders' Association at its last convention. The method employed was to ascertain the acceleration of a car, one of a string standing stationary on a slightly descending grade, the end car being struck by another car which was in motion.

The acceleration of the car which was struck was determined by means of a chronograph. In the tests, 55-ton and 90-ton cars, both light and loaded, were used, speeds at the time of impact ranging from .92 to 6.02 miles per hour. The results showed that the car weighing 48,000 lb., when struck by the moving car at a speed of .92 miles per hour, was affected by a maximum pressure of 12,600 lb., which rose to 158,500 lb., when struck by the moving car at a velocity of 5.54 miles per hour.

With a loaded car weighing 143,300 lb., struck by the moving car at 1.87 miles per hour, the force developed was 119,100 lb., which rose to 640,000 lb. when the moving car had a velocity of 4.76 miles per hour.

There was a loss of kinetic energy amounting to 70,000 foot-pounds in one test, concerning which Prof. Endsley remarks: "This can only be accounted for by the destruction of some part of the car."

It was further shown that the stationary car when struck had moved less than one inch at the time the maximum force acted on it.

This fact led to a further remark by Prof. Endsley, that since "this force occurred before car B (the car struck) had moved one inch, the damage to the end of the car would be just as great if only one car were standing, as if a dozen were backing it up, provided there was at least one inch slack between the first and second cars of the standing ones."

The forces of impact shown in these tests were certainly great, and their ability for causing destructiveness will be recognized. In the light of these tests, the life and durability of cars will be materially affected by the stresses to which they are exposed in switching service, which virtually consists of a succession of shocks by impact of varying degrees of severity.

**HARDNESS OF WATER.**—The designation "hard" is a general term, having specific meaning according to the particular use made of the water. For that reason hardness is generally stated in degrees, and the allowable degree for any given use is specified. According to Clark's standard, a degree of hardness consists of the presence of one grain of calcium carbonate, or its equivalent of another calcium or magnesium salt, per "imperial" gallon of 70,000 grains of water. The American standard is one grain per United States gallon of 58,381 grains of water, and for boiler use water is considered hard if it contains more than 8 grains of the salts to a gallon.—*Power.*

# CANADIAN NORTHERN PASSENGER CARS

Cars Have Steel Underframe and Body Frame With Wood Finish; For Transcontinental Service

The Canadian Northern during the past few months has placed a lot of 78 new passenger cars in transcontinental service, the equipment being divided into the following classes: 16 coaches, 15 baggage cars, five postal cars, seven dining cars, 11 standard sleepers, nine compartment and observation-compartment sleepers, seven tourist sleepers and eight colonist cars. The cars were built by the Canadian Car & Foundry Company at its Amherst, N. S., and Turcot (Montreal) works, the National Steel Car Company, Hamilton, Ont., the Crossen Car Company, Cobourg, Ont., and the Preston Car & Coach Company, Preston, Ont.

of the equipment is as follows: postal cars, 137,400 lb.; baggage cars, 131,000 lb.; day coaches, 140,000 lb.; 18-section colonist sleepers, 147,100 lb.; 14-section tourist sleepers, 153,000 lb.; 12-section drawing room sleepers, 154,000 lb.; observation-buffet-



Canadian Northern Standard 12-Section Stateroom Sleeper

sleepers, nine compartment and observation-compartment sleepers, seven tourist sleepers and eight colonist cars. The cars were built by the Canadian Car & Foundry Company at its Amherst,

compartment sleeper, 155,000 lb., and the 8-section state-room, drawing room sleepers, 155,000 lb. The coaches have a seating capacity of 84 for the second-class and 78 for the first-class and

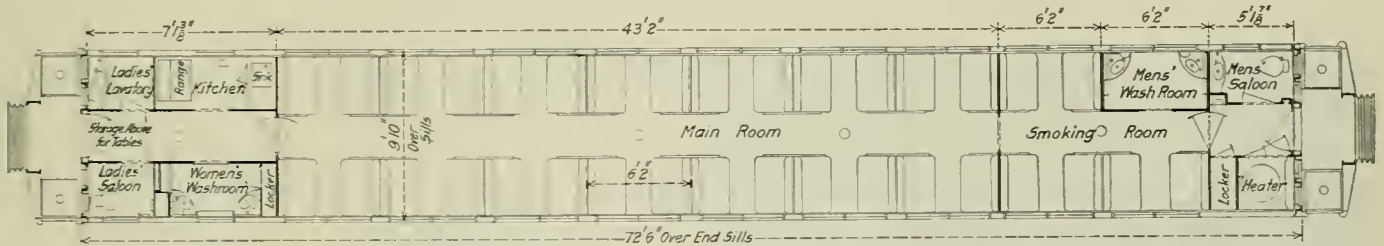

Floor Plan of 14-Section Tourist Sleeper—Canadian Northern

All of the classes are of a similar type of construction, having

the observation room of the observation sleepers will seat 25 persons.

The selection of the composite type of construction is due partly to climatic conditions and partly to the prevailing shop



Canadian Northern Postal Car

steel underframes and body frames with wood interior and exterior finish. The cars are all 72 ft. 6 in. long over the body end frames, have a width over the sheathing of 10 ft., and are all provided with six-wheel steel frame trucks. The light weight

conditions and equipment, which are favorable to the maintenance of cars of this construction. The winter conditions under which the Canadian Northern operates are especially severe. Extremely low temperatures accompanied by high winds are

often encountered on parts of the line, making a construction possessing the highest heat insulating properties very desirable. This consideration makes desirable the use of wood for interior and exterior finish.

The skylight does not project more than 3 in. above the roof of the car at its highest point.

The following is a description of the details of construction of the dining cars. These cars include some features not com-

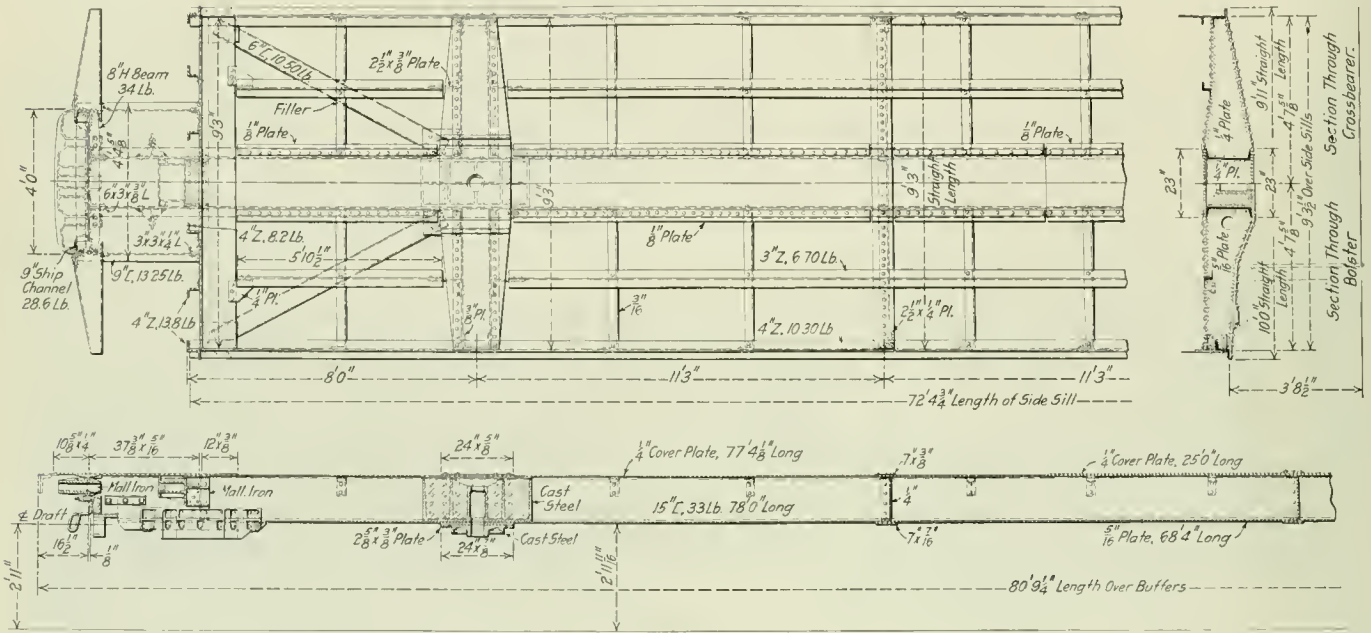

Steel Underframe; Canadian Northern Dining Cars

A feature of especial interest in the postal cars is a skylight which is placed in the roof of the upper deck. This considerably improves the lighting of the interior under daylight conditions. An opening 2 ft. 9 in. wide by 2 ft. long is provided in the roof of the car. This is fitted with a light metal casing and is closed with two panels of 3/8-in. rough-wired glass. The glass rests in a

mon to all of the other classes, but so far as uniformity is possible all classes are similar.

UNDERFRAME

The principal longitudinal members of the underframe are two 15-in., 33-lb. rolled steel channels, 77 ft. 10 1/2 in. long. Continuous top and bottom cover plates, 23 in. wide by 77 ft. 4 1/8 in. in length and 68 ft. 4 in. in length, respectively, are riveted to the flanges of the center sills. The top plate has a thickness of 1/4 in. and the bottom plate a thickness of 5/16 in. An additional top cover plate 1/4 in. thick by 23 in. wide is applied for a dis-



Interior of Canadian Northern Postal Cars

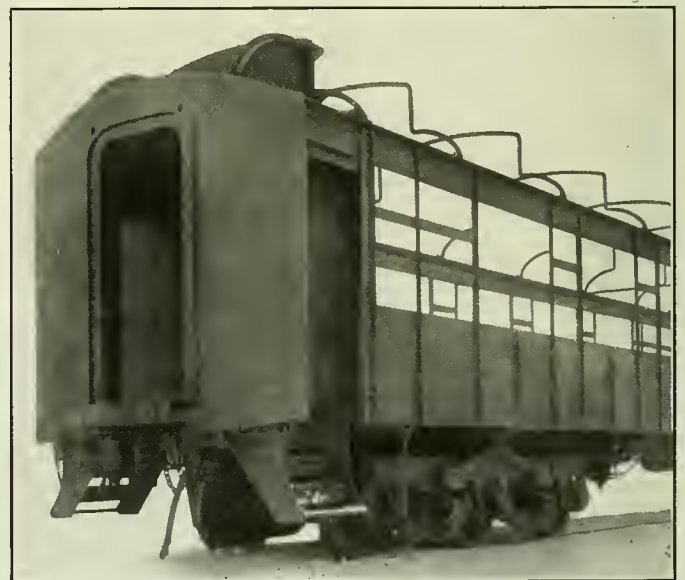

End View of the Dining Car Frame

2 1/2-in. by 3-in. wood support on the longitudinal center line of the roof, and slopes each way from this line. Rubber packing 1/8-in. thick is used all around to insure weatherproof joints. A horizontal curtain, the roller of which is placed near one side of the opening, is operated by a cord hanging from the opposite side.

tance of 12 ft. 6 in. each way from the transverse center line of the car. The draft lugs are riveted directly to the center sill, a Miner gear with a capacity of 150,000 lb. and a movement of 2 1/2 in. being applied. The draft gear works in unison with the Standard Coupler Company's platform attachment, having a



capacity of 42,000 lb. In addition to the capacity of the spring buffer and draft gear the center sill construction is designed to resist a buffing shock of 400,000 lb. with a factor of safety of

top and bottom cover plates. The top cover plate has a thickness of  $\frac{5}{8}$  in. and the bottom a thickness of  $\frac{7}{8}$  in. The bolster diaphragms are spaced 9 in. back to back and have flanges 3 in.

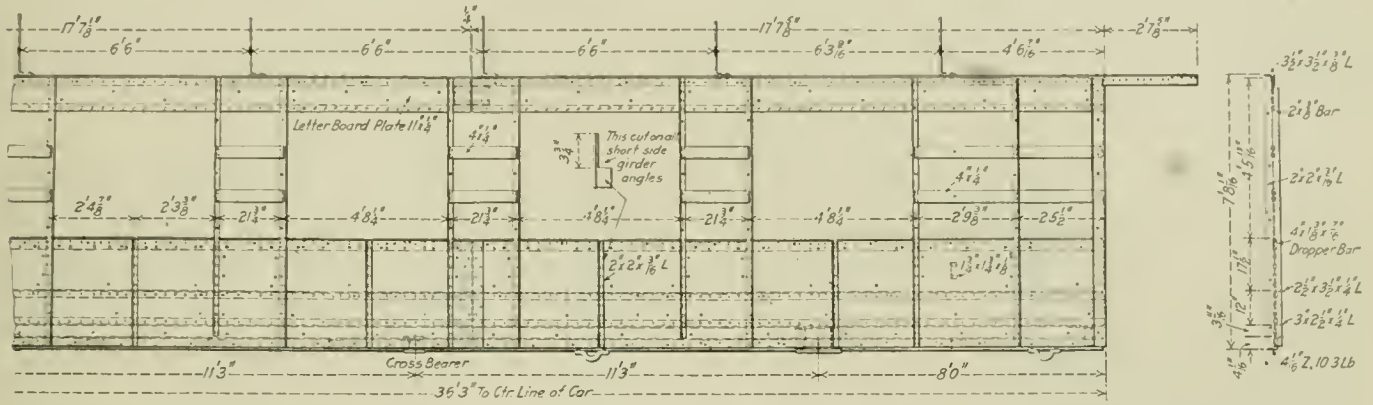

Steel Side Frame of the Dining Cars

$\frac{4}{2}$ . The original cross sectional and flange area of the center sills has been restored by the use of reinforcing members wherever it was necessary to cut the sills to allow piping to pass through.

The end sills are  $\frac{3}{8}$ -in. pressed steel diaphragms extending wide. The cover plates are 24 in. wide across the center sills, tapering to a width of 15 in. at the ends and riveted directly to the side girder construction. A steel filler casting is placed between the center sills where it forms a solid bearing for the body center plate. The center sills and side construction are further

The end sills are  $\frac{3}{8}$ -in. pressed steel diaphragms extending

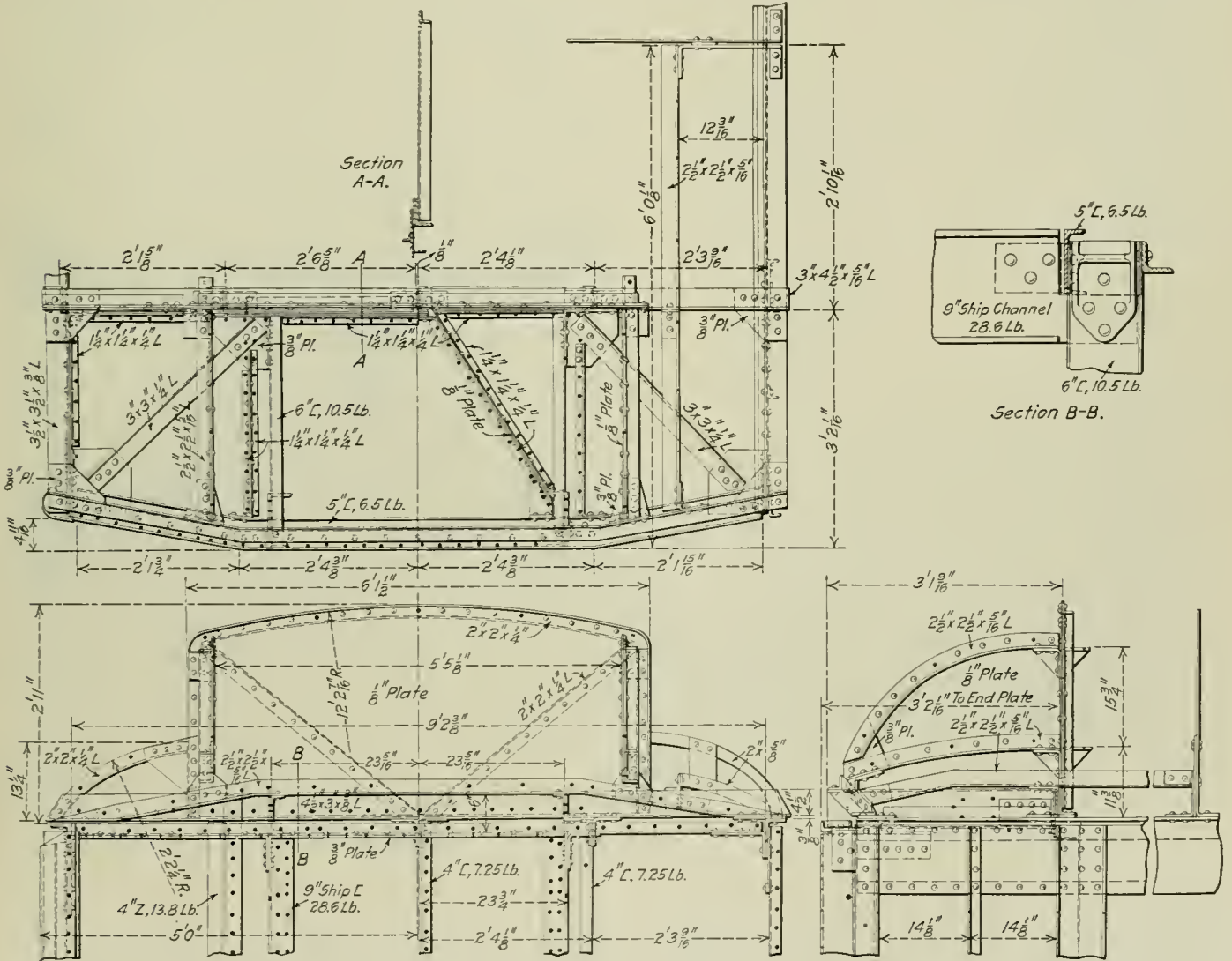

Details of the Hood Construction; Canadian Northern Dining Cars

between the side and center sills. To the top flanges of these diaphragms is riveted a  $\frac{3}{8}$ -in. plate, 12 in. wide, which extends across the underframe and forms part of the end sill.

The bolster is built up of  $\frac{3}{8}$ -in. pressed steel diaphragms and tied together by four cross-ties. These are made up of single  $\frac{1}{4}$ -in. pressed steel diaphragms and fillers to the top and bottom flanges of which are riveted cover plates 7 in. wide. The latter extend continuously from side sill to side sill, the thickness of

The bolster is built up of  $\frac{3}{8}$ -in. pressed steel diaphragms and

the top plates being  $\frac{3}{8}$  in. and the bottom plates  $\frac{7}{16}$  in. It has been found from experience in service that with this construction it is possible to support the center sill structure from the side sill girders so as to maintain the initial camber of  $\frac{3}{4}$ -in. at the center of the car, the trucks being 56 ft. 6 in. apart between centers.

Pressed steel channels  $\frac{3}{16}$  in. thick secured at the ends to

by  $\frac{3}{8}$ -in. angle corner plates at each sill. The vestibule bumpers are U-sections pressed from  $\frac{1}{4}$ -in. plate. They are secured to the backs of the 9-in. 28.6-lb. ship channel vestibule end posts, the lower ends of which form a part of the platform construction. The ends of the H-beam end sill are framed between the flanges of the ship channels, angle corner plates connecting the webs of the H-beam and the channels.

BODY CONSTRUCTION

The steel side frame is of girder construction with a bottom girder plate of  $\frac{3}{16}$ -in. material extending to a height of  $36\frac{1}{4}$  in. The letterboard plate is  $\frac{1}{4}$ -in. thick and has a width of 11 in. The side frame has a total height of 7 ft.  $83\frac{1}{16}$  in., the two girder plates being tied together by the 2-in. by 2-in. by  $\frac{3}{16}$ -in. angle side posts. Angles of the same section are used between the posts as vertical stiffeners on the lower plate. The lower edge of this plate is riveted to the web of a 4-in. 10.3-lb. Z-bar side sill and at points  $3\frac{11}{16}$  in. and  $15\frac{11}{16}$  in. from the top of the side sill, measuring from flange to flange, are longitudinal angles of 3-in. by  $2\frac{1}{2}$ -in. by  $\frac{1}{4}$ -in. and  $2\frac{1}{2}$ -in. by  $3\frac{1}{2}$ -in. by  $\frac{1}{4}$ -in. section, respectively. The flange of the lower angle serves as a floor support, while that of the upper or truss plank angle extends out into the interior of the car at a point just over the

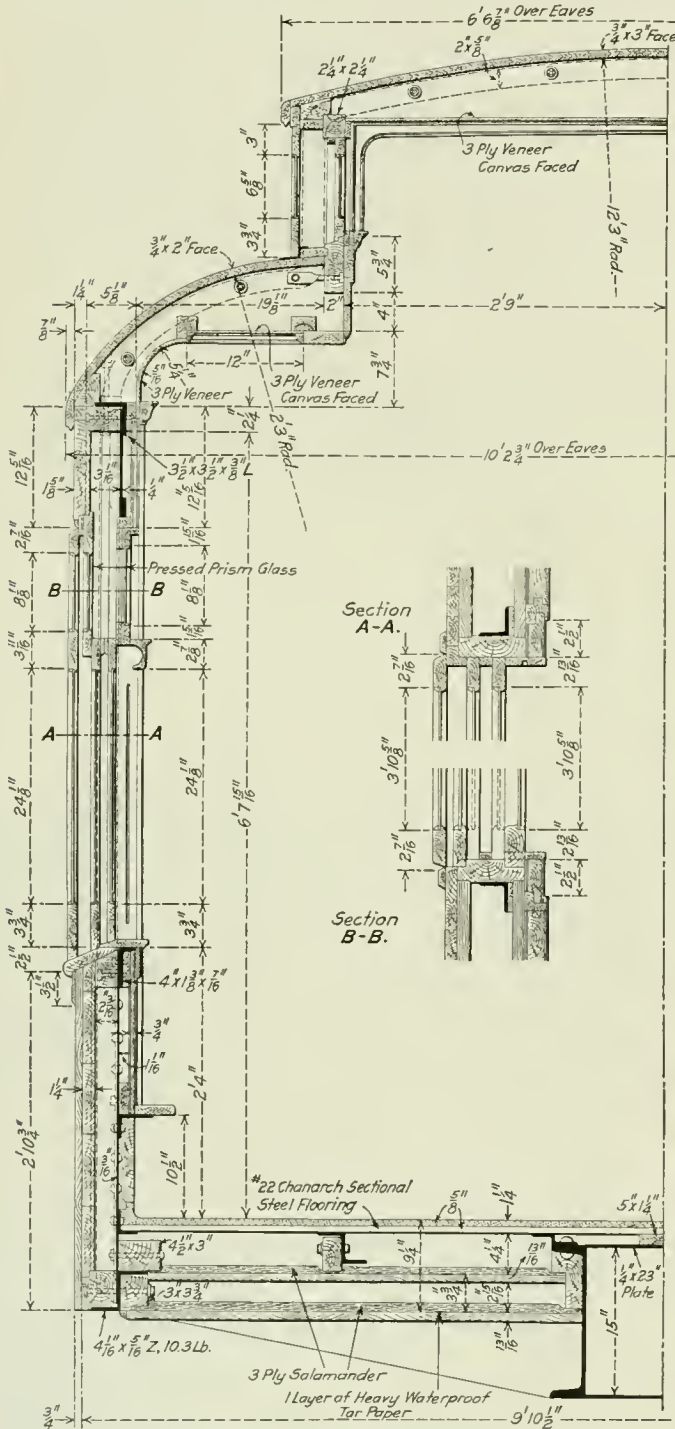

A Cross-Section of the Dining Cars



Interior of the Steel Frame; Canadian Northern Sleeping Cars

steam heat pipes. The top of the girder plate at the belt rail is stiffened by a 4-in. by  $1\frac{3}{8}$ -in. by  $\frac{7}{16}$ -in. dropper bar, riveted on the inside.

To the top of the letterboard plate is secured the  $3\frac{1}{2}$ -in. by  $3\frac{1}{8}$ -in. angle side plate which extends throughout the length of the car, including the vestibules. The lower edge of the letterboard plate is stiffened with a rectangular bar of 2-in. by  $\frac{3}{8}$ -in. section, riveted on the inside.

The body framing of all the passenger-carrying cars closely follows the arrangement of the dining cars, the variations being largely due to the difference in window arrangement. The arrangement of the postal and baggage cars differs considerably from this construction, however, in that the absence of side windows makes possible the use of diagonal braces between the side posts. This arrangement is illustrated by the photograph of the baggage car frames, which also shows the wood members to which the interior and exterior finish is secured, superimposed upon the steel frame.

the center and side sills, serve as additional transverse floor supports. Intermediate longitudinal floor supports of 3-in., 6.7-lb. Z-bar sections are placed between the center sills and side girder construction.

Each corner of the underframe is braced diagonally from the corner to the intersection of the bolster and center sill by a 6-in., 10.5-lb. channel, placed with the flanges down. The platform end sill is an 8-in., 34-lb. H-beam, carefully fitted and attached to the end of the center sills by means of two 6-in. by 3-in.

The end frame at the kitchen end of the dining cars is made up of a 4-in. by 13.8-lb. Z-bar corner post on the passageway side, an end door post of 4-in. 8.2-lb. Z-bar section on the outside and 4-in. 7.25-lb. channel section at the partition side. The latter post is located practically on the longitudinal center line of the car. A channel post of the same section is placed at the corner of the kitchen refrigerator, which occupies one side of the

Light steel paneling entirely protects the upper deck against fire.

FINISH

Superimposed upon the steel framework is a practically complete wood frame carefully fitted together and bolted to the steel members. To this the interior and exterior finish of the car are applied in accordance with wood car practice. The result is a type of construction which has proved in service to retain the good qualities of a wood car without the slightest tendency toward squeaking. The latter result is largely contributed to by the ample use of quilted cotton for all contacts between the framing and finish.

The floor is of No. 22 Chanarch sectional steel flooring, which is laid directly upon the steel floor supporting angles and Z-bars. This is covered with a composition flooring made up of Magnesite, sawdust and magnesium chloride, which is laid to a thickness of  $\frac{5}{8}$  in. To facilitate the proper cleaning of the floor and to prevent water from reaching the steel framework, this material is extended up around the sides and ends of the car to a height of 1 in. In the dining car it was considered advisable to cover this material with a supplementary floor of cork  $\frac{1}{2}$ -in. thick in order that the carpets might be removed during the summer months. Below the floor are two dead air spaces, the nailing strips for the insulating walls being bolted to the steel frame members. The lower wall is made up of a layer of 13/16-in. tongue and grooved material, upon which is placed one layer of heavy waterproof tar paper and a layer of 3-ply Salamander. The intermediate wall is similar to the lower one except that the layer of tar paper is omitted. A single layer of 3-ply Salamander is placed over the center sill, crosssties and bolsters.

The deck is closed in tightly and glazed on account of the difficulty of keeping rain out where the deck sashes are not securely screwed in place. Special care is necessary to secure weather-tight joints, because the prevailing winds are north and south over a greater part of the transcontinental route. The roof is surfaced with No. 6 canvas, laid in white lead and oil.

The cars are equipped with 5-in. by 9-in. 6-wheel trucks of all-steel construction. The car body and the trucks are securely locked together by the use of the Coleman center pin in connection with a Wood roller center plate. Wood roller side

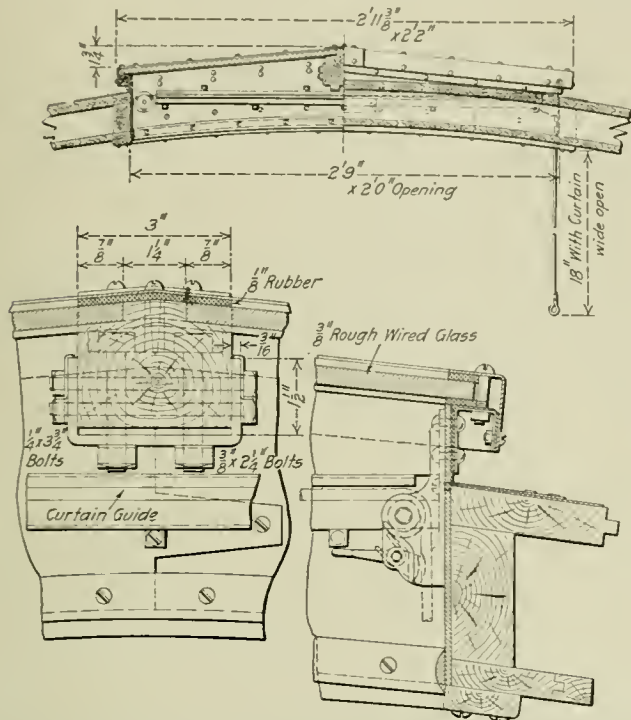

Details of the Postal Car Skylight

vestibule. The body corner post on the refrigerator side of the car is replaced by an 8-in. 13.75-lb. channel placed with the back parallel to the side of the car and the flanges out.

At the other end of the car the framing is symmetrical owing



The Body Framing of the Baggage Cars

to the location of the end door on the center line. Here the corner posts are 4-in. 13.8-lb. Z-bars, and the intermediate posts are of the same section. The door posts are 4-in. 8.2-lb. Z-bars. All end posts are riveted to the outer face of the end sill, the whole construction forming an into-telescoping partition.

The hood construction is such as to form practically a horizontal girder by which any load against the upper part of the vestibule end posts is distributed to the side frames of the car.

bearings are also used.

In common with all railroads operating in northern climates, it is the practice of the Canadian Northern to use a combination heating system. The cars are equipped with the Gold Car Heating & Lighting Company's 2-in. by 1-in. duplex coil system of hot water circulation, it being possible to have both fire and steam in the heater at the same time.

The problem of keeping heater drips and basin and sink drains

from freezing in severe weather is one which has been difficult to solve. Trouble from drains freezing has been experienced even where pipes  $1\frac{1}{2}$  in. in diameter are used. All drains are now fitted with a simple thaw-out device adopted after a number of experiments. A 3-in. pipe sleeve, open at the lower end, surrounds the drain pipe where it passes through the floor and insulating walls. This is closed at the top, above the floor, with a cap to which is connected a  $\frac{3}{8}$ -in. thaw-out line, taking steam through a special choke fitting from the steam train line. A globe valve in the thaw-out line permits the operation and control of the device from the interior of the car. In order to avoid uncoupling cars to thaw out frozen heater drips, all cars are equipped with a thaw-out hose steam connection and each baggage car carries 50 ft. of hose in a sealed locker for this use only.

The cars are provided with the Stone axle generator system of car lighting. Arnoldi ventilators are used, the dining car being equipped with enough of these ventilators, in connection with side intake ventilators, to provide ten changes of air per hour in the dining room. The kitchen is provided with a hood ventilator and an electric exhaust set together with two top deck vents, which provide for 20 changes of air per hour when standing or 35 changes per hour when running.

### THE FOUNDATION BRAKE GEAR\*

The most important parts of a brake, in my estimation, are the rods, levers, brake beams and attachments, through which the force is transmitted, and no matter how perfect are the brake shaft and its attachments, the triple valve and brake cylinder, the full effect of the brake is not realized, unless all other parts that transmit the pressure to the wheels are in good condition and in proper position.

The safety appliance law will compel inspectors to be familiar with the brake parts at the end of the car. The Master Car Builders' rules cover the up-keep of the triple valve and cylinder, but there are no rules prescribed governing the lengths of brake rods, neither is there any information given out generally outlining the proper proportion of brake levers and it appears to be a matter that inspectors and repairmen are not generally familiar with. Cars are placed on repair tracks and receive brake repairs and when completed, there is a possibility under present conditions of having a different brake pressure on each pair of wheels, which, no doubt, accounts, in many cases, for one pair of wheels sliding under a car. It is the practice to remove the triple valve for test when sliding occurs and if found in good condition it is replaced, but there are times when the leverage is not checked to see that the pressure is evenly distributed; then again, the man applying the brake rigging is very apt to apply rods and levers that bring the pressure far below the percentage which the car should have.

It is acknowledged that the greatest defect of hand brakes today is the uneven amount of slack in brake chains and until the brake rigging is properly applied and adjusted, it will continue to be a menace.

There is another thing which I believe has come to the attention of all car men and that is the use which is made of the dead lever guide. Its purpose is to take up the slack caused by brake shoe wear, but most repairmen utilize it to take up the slack existing in the levers, instead of adjusting the brakes at the bottom connection, thereby leaving no room to take up the brake shoe wear. When applying a top rod, extreme care should be taken to see that the push rod is forced back into the cylinder as far as it will go, and the cylinder lever is at right angles. Care should also be exercised to see that the push rod is up against the piston head; if not, it is too short. If the cylinder lever cannot be placed at the proper angle, because of the push rod striking the piston head, it is proof that the push rod is too long. Written instructions governing this class of work cannot

\* From a paper by Chas. Page, Air Brake Inspector, New York Central, read at the October meeting of the Niagara Frontier Car Men's Association.

very well be given to cover all classes of equipment and it is, therefore, the duty of the man following such work to educate himself to a point where he can tell at a glance what is wrong.

To determine the dimensions of levers to be used on a freight car, take 60 per cent of the light weight, which we will assume is 32,000 lb., giving a total braking power of 19,200 lb., and divided by 4 (the number of brake beams), which gives a load of 4,800 lb. on each beam. The truck lever dimensions usually employed are 8 in. by 24 in. Next multiply 4,800 by 8 and divide by the total length, 32 in., which gives a pull of 1,200 lb. on the top rod; this, multiplied by the total length of cylinder lever, which we will assume is 25 in., and divided by 3,700 lb. (which includes the pull on the top rod, plus 2,500 lb., the force exerted on piston), will give  $8\frac{4}{37}$  in., or the length of the power arm of cylinder lever. Subtracting 8.11 in., the length of power arm, from the total length, leaves 16.89 in., the length of the other arm.

We should not lose sight of the fact that careful attention should be given to the brake lever key bolts to see if they are worn, and to brake levers, to determine if the holes are elongated, in which event they should be replaced. There are other things that cause too much slack in the brake rigging, such as worn brake heads, long body rods, short truck brake connections and loose cylinder and reservoir brackets. Careful attention should be given to detect these conditions and, of course, the matter of brake adjustment should be followed up at all times.

### RECLAIMING CAR TRUCK PEDESTALS

The application of oxy-acetylene welding to worn passenger car pedestals is a practice followed by the Chicago, Burlington & Quincy at the Aurora shops. When the pedestals have worn to such an extent that it is impracticable to use them further, they are removed and the worn parts built up, as indicated in

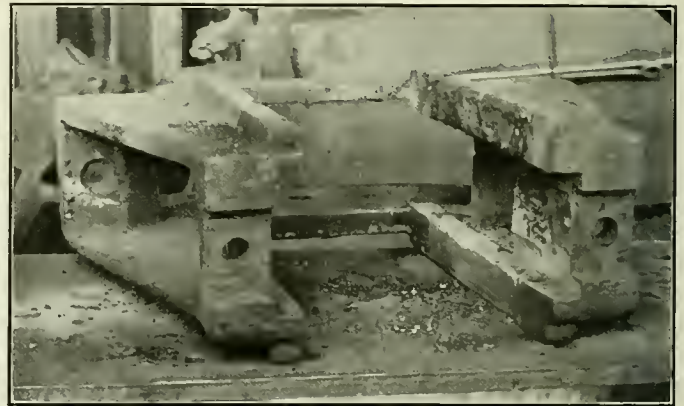

Worn Jaws of Car Truck Pedestal Built Up by the Oxy-Acetylene Process

the illustration. The built-up surfaces are smoothed by grinding and the pedestals are then reapplied, being practically as good as an entirely new casting. The cost of thus repairing the pedestals is small and a substantial saving is made as compared with the cost of new castings.

**SAFEGUARDING DANGEROUS DOORWAYS.**—DOORS are often located so that they open directly upon railroad tracks. In such cases prominent danger signs should be displayed; substantial railings should also be fixed in place, just outside the doors, to prevent persons from walking directly out upon the right-of-way. Similar railings should be placed wherever tracks come dangerously near to buildings, and if the space between a building and a track is so narrow that a person standing there might be crushed by a passing train, this space should be covered over by boards or by metal plates, inclined at such an angle that it is impossible for anyone to walk or stand in the region of danger.—*Travelers' Standard.*

# REPORT OF I. C. C. DIVISION OF SAFETY

## Defective Uncoupling Mechanism and Inoperative Brakes Criticised; More Supervision Needed

W. H. Belnap, chief of the division of safety of the Interstate Commerce Commission, in that part of his report for the year ended June 30, 1915, which refers to safety appliances, develops some facts which demand the attention of every car department officer. The following is taken from his report:

The number of inspectors has been increased during the year, making possible a substantial increase in the number of cars inspected. There is also an appreciable reduction in the proportion of the number of defects reported to the number of cars inspected as compared with previous years, which is partly explainable from the fact that the greater number of inspectors has made it possible to have each inspection point visited more frequently and partly from having heavier equipment placed in service and lighter equipment discontinued.

In order more graphically to show the results of inspections during the year, a comparison is here made of some of the figures for the fiscal years ending June 30, 1914 and 1915:

	1914	1915
Freight cars inspected.....	790,822	1,000,210
Percent defective.....	5.79	4.77
Passenger cars inspected.....	26,746	33,427
Percent defective.....	1.04	2.85
Locomotives inspected.....	32,761	38,784
Percent defective.....	4.98	4.06
Number of defects per 1,000 inspected.....	67.48	57.23

The decrease of 1.02 in the percentage of defective freight cars is most gratifying, especially in view of the fact that in addition to maintaining appliances in operative condition carriers have been charged with the duty of standardizing their old equipment. The increase in the percentage of defective passenger cars was occasioned by the fact that on July 1, 1914, the extension of time granted by the commission for bringing this class of equipment to the standard prescribed expired.

### DEFECTIVE UNCOUPLING MECHANISM

The number of defects reported in coupling and uncoupling mechanism directs attention to the necessity of a system of rigid inspection if these parts are at all times to be kept in proper condition. The master Car Builders' Association is continuing its efforts to develop and secure the adoption of a standard coupler. The report of the committee on couplers of the association is an interesting commentary on the results secured in tests of the present types of couplers and the two experimental ones that are being tried out. The use of many different kinds of couplers, some of doubtful efficiency, and the consequent difficulty in securing their proper maintenance and repair is a prolific cause of injury to employees, as well as one of the principal causes of prosecution for violation of the safety appliance acts. The adoption of a thoroughly tested coupler, which will combine the qualities of efficiency, simplicity, and strength, can not be too strongly commended.

Experience has shown that a material percentage of defective and inoperative couplers is now caused by using wrong parts in making repairs. It is apparent that repairmen are not familiar with the different parts of the various couplers, or else have not been provided with the proper material with which to replace defective parts when repairs are necessary. The result is that after a short period these improper repairs become defective and the coupling mechanism becomes inoperative. Repairs of this character when made are almost impossible to detect unless the cars are separated and the couplers carefully examined.

The general lack of efficiency of many of the designs of uncoupling mechanism is cause for grave concern, for while there has been a large decrease in the number of broken and kinked chains, these defects, which render the mechanism totally inoperative, constitute 50 per cent of all the defects under the

heading "uncoupling mechanism." Defects of this character could be corrected by the use of any device having rigid connection of the lever and the lock or lock lift, thus eliminating the troublesome chains and doing away with the chief cause for prosecution under the safety appliance acts. The importance of eliminating many of the defects inherent in certain of the uncoupling mechanisms now in use can not be too strongly urged.

### RUNNING BOARD CONDITIONS IMPROVED

During the past year there have been fewer causes for criticism with regard to the manner of applying running boards to saddle blocks than have been noted in former years, which evinces a better understanding of the commission's order, in that there are now found comparatively few cases where running boards have been applied with fluted nails or drive screws. There exists, however, a tendency to drive the screws, with which the order prescribes the boards may be fastened. A few cars now being put in service have their running boards secured with bolts, which represents the ideal secure fastening required by the law.

### POWER BRAKES IN OPERATIVE CONDITION

The opinion recently rendered in the case of the Virginian Railway Co. v. The United States of America is most important and its effect will be far-reaching. The decision in this case was to the effect that trains must be controlled by the power brakes prescribed by law, and that even though there be 100 per cent of the power brakes in the train in operative condition, the use of the hand brakes for the purpose of controlling the speed of the train is unlawful. It was further held that just as the object of the automatic coupler is to keep employees from going between the cars, so the object of the train brake is to keep employees from going on top of trains to set and release hand brakes. The hand brake is an important feature of the equipment of every car, as it is necessary in controlling the speed of cars being set onto sidings and made up into trains. Another recent hand-brake decision of importance defines the word "efficient," as used in the statute as comprehending the efficiency of the hand brake for the purpose of holding a car or train, as well as its efficiency as a matter of safety to employees engaged in work requiring the use of hand brakes.

The maintenance of the power brake on each car in proper condition is the only hope for alleviating the power-brake troubles in the operation of trains. Many of the railroads are now insistent in their demands for 100 per cent efficiency in the operation of train brakes leaving terminals, and seem to be experiencing no particular difficulty in securing it. However, by far the greater majority of the roads operate their trains under the assumption that in having 85 per cent of the cars in such trains with power brakes in operative condition they are meeting all the requirements of the law on this point. It is clearly manifest that the intention of the commission as set forth in its order of June 6, 1910, was plainly that all power-braked cars in trains should have their brakes used and operated from the locomotive drawing the train, and several suits have been instituted that this part of the law may be tested in the courts.

Only by a careful system of inspection and through test at terminals can 100 per cent efficiency of brakes be secured, and it is not unreasonable to demand that such careful test and inspection be made. Each brake should be tested so as to know if the piston moves forward enough to close the leakage groove, and not more than 10 in. when a full service brake application is made from at least a 70-lb. brake pipe pressure, and remain so until the usual inspection is made, releasing properly by the ordinary method in making terminal tests. Working toward this end, it is

gratifying to note that the carriers are educating their inspectors in the more efficient discharge of their duties and are securing men who have a better knowledge of the complicated brake systems and the problems in maintaining them. However, the proper means of making tests of brakes must be provided, so that cars may be tested before they go forward.

The need of efficiently operated brakes continually becomes more pressing, owing to the constantly increasing length of trains on level roads and the ever increasing tonnage handled on railroads with heavy grades. As the length of trains increases the difficulty of maintaining power brakes increases.

Owing to defective connection, leaky train pipes, and train pipe friction, with trains the length of many now handled daily on some railroads, it is extremely difficult to maintain adequate brake pipe pressure on the rear of the train. This condition is a source of danger, as smooth, uniform, and safe handling of the air brake system is not possible where there is such variation in train line pressure as has been found to exist.

An air brake gage in the caboose, together with a conductor's valve that is readily available in case of emergency, is important for the proper handling of long trains. Without this gage to indicate the train-line pressure, the trainmen on the rear of the train are in ignorance of the air pressure available for use and have no means of knowing with certainty whether their trains have sufficient air in reserve properly to control them.

Disregard for the law or misunderstanding of the proviso of section 6 of the act of 1893, as amended, is still shown by cases reported of the indiscriminate handling of logging cars having drawbars of various heights in connection with other equipment. The language of this proviso is so plain that there appears to be no justification for any violation of it.

The handling of chained up cars in revenue trains or in connection with cars commercially used is less prevalent now than heretofore, but occasional instances are still reported. The proviso in the act of 1910 does not permit the hauling of defective cars by means of chains instead of drawbars in revenue trains, or in association with other cars commercially used, unless such defective cars contain live stock or perishable freight, and any violations that are discovered are presented for prosecution.

Quite a number of cars have been found equipped with handholds less than 16 in. in clear length, there being nothing to prevent the application of 16-in. handholds if the carrier desired to use them. The order permits the use of 14-in. handholds only where it is impossible to apply those 16 in. in length.

#### INTERCHANGE OF EQUIPMENT

Owing to the lack of familiarity on the part of many employees with the requirements of the safety appliance laws, the matter of interchange of equipment continues to produce much controversy and misunderstanding. Under the decisions of the courts any movement of a car with defective safety appliances subjects the carrier to the statutory penalty unless it is such a movement as comes within the proviso of section 4 of the act of April 14, 1910. This proviso permits a carrier to make a movement for the purpose of repair only where a car becomes defective while being used on this line of railroad, and then only from the point where it is first discovered to be defective to the nearest available point where it can be repaired, provided further that such movement is necessary to make such repairs and that such repairs can not be made except at such repair point. Notwithstanding the plain provision of the law that the right to move a defective car for the purpose of repair is limited to the carrier upon whose line of railway the car becomes defective, cars are delivered and received in interchange and subsequently moved for the purpose of repair. The mere fact that the movement of traffic will be facilitated and congestion prevented does not warrant the movement under such circumstances of cars not in the condition required by law. A railroad is under no obligation to receive defective cars from connecting lines; but if it does so, it can not thereafter lawfully move such cars even for the purpose of repair. In order to escape the statutory penalty they must be repaired where they stand and can not be otherwise used or

switched about in its yards. Many defects are of such a nature that they can be readily repaired on the interchange track and no real necessity exists for their further movement in defective condition. Some complaint is heard of the alleged hardship occasioned by the receiving line's refusing to accept cars with defects which can not be repaired on the interchange track and by so doing requiring the delivering line to return the car to its own repair track. Such deliveries are often made regardless of the condition of the safety appliances and for the sole purpose of expediting the movement of the freight. Where the carrier knows, or upon a proper inspection should know, the condition of the car, and is so unmindful of the duty imposed upon it by the statute, it can not be heard to complain. It is believed, however, that in a majority of instances defects of this character would be discovered by a careful inspection of the cars before they are moved to the interchange track. Often too little attention is paid to apparently unimportant defects with the result that minor defects on cars leaving the yards often lead to more serious defects by the time they reach the interchange track.

#### GENERAL TRAVELING INSPECTORS

A better understanding on the part of railroad employees of the requirements of the law and the methods of making proper repairs will go far toward minimizing many of the present difficulties. Several of the railroads have general traveling inspectors who go from one inspection point to another, consulting with the inspectors and repairmen, and giving instructions and advice on the many technical questions that so frequently arise. The results of this educational method have been most gratifying, and it is to be hoped that such methods of improving safety appliance conditions will be more generally adopted.

Prosecutions for the movement of defective cars are not instituted with the idea of imposing undue hardship upon the carriers, but because experience has demonstrated that prosecutions are often necessary to secure compliance with the statute. It is believed that a better understanding of the methods employed in the inspection of safety appliances would lead to more cooperation on part of the carriers. Under the policy followed from the inception of our inspection force, by far the greater portion of our inspectors' time has been devoted to inspecting equipment in the yards, accompanied by representatives of the carriers. During these inspections all safety appliance defects are brought to the attention of the representative of the carrier and an explanation is made of the requirements of the law as set forth in the printed pamphlets distributed by the commission. Monthly reports of these inspections are sent to the presidents of the various railroad companies, directing their attention to any defects that may have been found in their equipment. Where conditions indicate a continuing disregard of the law or a lack of vigilance in inspecting and repairing equipment, inspectors secure evidence for prosecution and in obtaining this evidence do not make themselves known to the representatives of the railroad companies, for, as pointed out in the decisions of the courts, if inspectors were required to notify the carrier of the defective condition of a car before it was moved it would be impossible to secure effective enforcement of the statute.

Inspectors enter upon every investigation with a desire to perform their duty as officials directed to aid in the execution and enforcement of the law, and the prosecutions instituted by no means represent isolated instances of failure to comply with the requirements of the statute. A suit to recover the statutory penalty is filed only in a case of manifest dereliction of duty.

Much of the improvement in the direction of proper compliance with the provisions of the safety appliance laws has been accomplished through the spirit of hearty cooperation manifested on part of the carriers. In most instances our inspectors are shown every courtesy, and their suggestions as to the proper application and maintenance of safety appliances receive careful attention. Employees engaged in the work of car maintenance take considerable pride in having satisfactory reports made on the conditions found to exist in their yards and this spirit accounts in a great measure for the betterment in conditions.

# THE CAR INSPECTOR AND HIS JOB

## A Combination of Articles Received from Seven Contributors to the Car Inspectors' Competition

Each of the last three issues of this journal contained articles that were submitted in the car inspectors' competition, which closed October 1, 1915. This article is a combination of the papers submitted by seven contributors, located in various parts of the country from New England to Kansas. These seven contributors are C. L. Bundy, general foreman, Delaware, Lackawanna & Western, Kingsland, N. J.; W. T. Clanton, car foreman, Illinois Central, Cairo, Ill.; G. H. Heiter, chief car inspector, Louisville & Nashville, Mobile, Ohio; H. T. Mabry, car clerk, Atchison, Topeka & Santa Fe, Topeka, Kan.; John C. Murdock, Boston & Albany, Allston, Mass.; W. W. Warner, foreman car department, Erie Railroad, Cleveland, Ohio; and W. G. Walker, car inspector, Chesapeake & Ohio, Silver Grove, Ky.

### IMPORTANCE OF SELECTION

Those who have had experience in handling men will concede that it is next to impossible to train them to perform satisfactorily any duty or work that they dislike. Experience teaches us to select men with great care for positions of any real importance. Much valuable time and money will be wasted in trying to educate a man to be a car inspector if he does not like this kind of work at the start.—(*W. W. Warner.*)

### RESPONSIBILITY FOR TRAINING

The statement has been made that it is difficult to procure capable men for the position of car inspector. If it is true there must be something wrong with the organization of the car department as a whole. We may examine this statement from an American point of view. "If you would be well served, be your own servant." Good capable men are not like a mushroom and do not grow over night. They must be developed. If you want good men, serve yourself with them by having a system of your own to develop them. You will then know they are good, as you know the conditions under which they received their training. You also have developed yourself into a position where you do not have to depend on men of whom you yourself have no knowledge.—(*John C. Murdock.*)

### THE INSPECTOR'S RESPONSIBILITY

The M. C. B. rules represent the laws governing the joint responsibility of foreign roads to home lines. If the inspector is not capable, or is slack in the performance of his duty, the road he represents carries a high expense account which should be reduced by damages paid by other roads under the M. C. B. rules.—(*John C. Murdock.*)

Most of the tonnage carried is destined to points off the line originating it and cars therefore must pass the inspectors of a number of different roads in getting to their destination. It is therefore necessary, for the prompt movement of freight, to have good broad gaged common sense inspectors. Cars should be held up only when their condition is such that they are not in safe condition to go forward.—(*C. L. Bundy.*)

### COMPLICATION OF RULES

While the M. C. B. rules governing the interchange of cars are based on business principles, they are all more or less complicated and different interpretations are placed on different rules by different men. It is necessary for the M. C. B. Association to have a committee, known as the Arbitration Committee, to pass on all disputes referred to it for settlement and it is often called upon to settle cases referred to it for a decision.—(*C. L. Bundy.*)

The car inspector is required to work 11 or 12 hours a day, with very little time to study the rules, or to keep posted on the different duties that he has to perform. If he was on an eight-

hour shift it would give him time to study the rules, and keep well posted on safety appliances, combination defects, use of wheel and coupler gage, etc. The interchange rules are hard to understand if an inspector does not take a great deal of time to study them out; in fact, many of them are apparently conflicting, if not thoroughly understood.—(*W. T. Clanton.*)

### QUALIFICATIONS OF CAR INSPECTOR

A car inspector should be able to read and write fairly well; should have good eyesight, so that he may be able to see defects if they exist; should be physically able to get around and climb over cars in making inspections; should be industrious, as there is no room for the lazy fellow; should be of a good disposition in order to get along with inspectors of other lines, and his hearing should be good.—(*C. L. Bundy.*)

A car inspector should have a good character, the trait of observing, and a desire to do unto the other inspector as he wishes to be done by. Too many interchange inspectors get the idea that their employer wants them to try to "put it over on the other fellow" whenever he gets a chance. This is entirely wrong. Whenever a car is held up it means that a shipment is being held, if it is a loaded car, or, possibly, if it is an empty, some shipper is holding his shipment until the car arrives; in any case some one will have to pay the per deim.—(*W. W. Warner.*)

An inspector should possess good health, be energetic, not a shirk, have a fair education so that his reports of defects existing on cars inspected can be understood by others who handle them, a quick eye, a good memory, and good judgment.—(*H. T. Mabry.*)

He should be a man with a disposition to get along agreeably with his neighbors—the inspectors on other roads who inspect cars against him. If not, he will find many cars held up by them for minor defects that would be perfectly safe to run; as a result important freight will be held up. I feel that this is one of the most needful qualifications of a car inspector—to get along with the other fellow and give and take a little, as it were, in order to keep cars moving through to their destinations.—(*C. L. Bundy.*)

A man who deserves to become a car inspector should possess a common school education that he may acquire the proper knowledge and conception of the various codes of rules pertaining to the position. He should be a man whose honesty and integrity will at no time be questioned by his superior officers. His habits must be good. He must not be given to the use of intoxicants. He must be studious, industrious and constantly on the alert, and at all times mean business.—(*G. H. Heiter.*)

In addition to being a young man, he should be able to read and write fairly well, at least; he should have a keen eye for detecting cracked wheels, loose wheels, cracked arch bars and many other similar defects; he should be somewhat athletic, as there is considerable climbing over cars in making inspections.—(*C. L. Bundy.*)

### KNOWLEDGE REQUIRED

A car inspector should know the parts of a car, and their value to the car as to safety. He should be conversant with the M. C. B. rules, Arbitration Committee decisions, and all circular matter pertaining to the interchange of and running of cars. He should know when open cars are properly loaded, single, or in group; be familiar with the U. S. safety appliance standards; also able to pass on high cars, and the height and width of loads on open cars to pass published clearances. He should be able to select a suitable car for all kinds of commodities, particularly explosives and inflammable material; be able

to determine the nature and extent of needed repairs, to make cars safe for trainmen, and safe in regular train service. He should possess decisive power, and exercise good judgment to facilitate the movement of freight.—(*E. G. Walker.*)

#### TRAINING

Much depends on the method pursued for developing men for this kind of work. We cannot place an inexperienced man on an interchange and expect him to make good from the start. We must give him an opportunity to learn the method of inspecting cars, the proper interpretation of the M. C. B. rules, etc. This can best be done by placing a new man with an experienced one who has enough interest in his fellow man to give him the necessary instructions and advice. Success or failure depends very much on the kind of a start that the new man gets. If he is impressed with the importance of his part of the work and is given the proper instructions and has the right qualifications he will be a success.—(*W. W. Warner.*)

Put bright young men about 25 years of age in the shop or repair yard, working on all kinds of cars, for about one year at least, preferably two years; then place them with an experienced car inspector in the yards inspecting cars.—(*C. L. Bundy.*)

The car inspector should be selected from young, energetic, sober men on the repair tracks. Here he acquires the knowledge of different parts of cars, their location, and as to whether repairs are properly made standard to the car. He should be perfectly familiar with this work. Then he should be given the M. C. B. rules; M. C. B. loading rules, and U. S. safety appliance regulations, so he can familiarize himself with the rules governing the interchange of cars. He should then be placed with an experienced interchange inspector, who can explain the rules, and teach him their meaning and workings. This can be done by reading the rules, one at a time, and explaining them; then see that he understands each rule, also that he thoroughly understands what constitutes a combination of defects, what are delivering line, or owners' defects. Also explain thoroughly the use of the billing repair card; M. C. B. defect card; joint evidence card; the partial repair card, and cardable defects.—(*W. T. Clanton.*)

A man should serve not less than six months in a car shop, for it is there that he has the opportunity to become familiar with the various parts of cars from the rail to the running board. He learns how to frame and construct; he becomes familiar with all the standards of material, and where it belongs. From the shops he should go into the yards with a reliable inspector, where he can be instructed in the daily practice of inspecting trains in and outbound.—(*G. H. Heiter.*)

The car inspector must have a training in car construction and repairs by actual experience under a qualified foreman, also a theoretical knowledge of the rules governing the condition of, and repairs to freight cars for the interchange of traffic. Thus qualified and trained he should be placed under the supervision of an experienced and qualified inspector that he may gain experience in the interpretation and application of the rules by actual inspection and application.—(*H. T. Mabry.*)

The car foreman, general foreman, or master mechanic, should call all of his inspectors together once each month, or oftener, and go over the most difficult rules, or the ones that are not thoroughly understood.—(*W. T. Clanton.*)

Send them to M. C. B. conventions and furnish them with reading material to add to their knowledge.—(*John C. Murdock.*)

#### DUTIES

The terminal inspectors' duties are to inspect all cars in trains as they arrive at the terminal, marking out such cars as are found to be in bad order. While it is not absolutely necessary for them to be experts on the M. C. B. rules of interchange, it is well for them to be fairly well posted in this respect. Inspectors at interchange points should be well posted on the M. C. B. rules of interchange, in addition to their other qualifications, which include all the qualifications of the terminal inspectors. There are so many things for car inspectors to look after that it is hard

to outline all of them. The most important thing, in addition to inspecting cars, is to keep a thorough record of all cars delivered from one road to the other. This record should show dates, car numbers and initials and defects, if any; also record of M. C. B. defect cards, if car is so carded. He should be able also to furnish the proper information for billing on all work done to foreign cars.—(*C. L. Bundy.*)

#### EXAMINATIONS

The car department should examine its men on the M. C. B. rules and rate them on a percentage basis. In case of vacancy in the inspection force promote the man with the highest percentage.—(*John C. Murdock.*)

The responsibilities that inspectors have are such that means should be employed to know their qualifications and fitness, and by examinations to determine the extent of their knowledge of the rules, thus inducing them to keep posted and up to date. The incompetent and non-progressive inspectors can thus be located and eliminated.—(*H. T. Mabry.*)

#### HELPING THE INSPECTOR

At some of the large interchange points local rules governing the interchange of cars have been put in force with good results. If the railroads would institute a rigid inspection of all cars while they are empty and have needed repairs made, most of the difficulty would be overcome and the poor car inspector would be relieved of much of his trouble.—(*C. L. Bundy.*)

#### COMPENSATION

There are few persons who are natural students and who study for the sake of knowledge only. In order to make inspection positions attractive they must be rated higher as far as wages are concerned. There must be some inducement to encourage men to give up their leisure time outside of working hours to study. Take the locomotive firemen who have to pass first, second and third year examinations on mechanical subjects, also one on train rules and air brakes. Many give this work up, even with the prospect of higher wages, because they must pass a certain percentage to become eligible for engineers.—(*John C. Murdock.*)

The M. C. B. rules, because of the varied conditions which they have to cover, have become so complicated and interlocked that only the men who are qualified and trained can understand and apply them properly. To secure and retain competent men for inspectors adequate compensation should be paid them, thus inducing the inspectors to appreciate and strive to retain their positions by faithful service.—(*H. T. Mabry.*)

The master mechanic should offer the inspector every opportunity possible, as the better posted the inspector is the better service he will render. Great responsibilities are placed on his shoulders, and he should report to, and receive instructions from the proper source in the mechanical department, and not from officers in some other department. Then he should be paid well for his work and enjoy a vacation each year, the same as other salaried men.—(*W. T. Clanton.*)

#### PROMOTION

The car inspector has opportunities for advancement equal to any employee in the car department. He can rise to the position of chief inspector, chief joint inspector, general inspector, car foreman, general foreman and many other positions of importance. In order to do this, however, it is necessary to keep up with the times, be constantly on the job, have a determination to win, and live strictly up to the instructions.—(*W. W. Warner.*)

A man that is thoroughly familiar with the rules and proficient in the discharge of his duty will certainly prove qualified for greater responsibility.—(*G. H. Heiter.*)

By giving him opportunities to attend conventions and meetings with chief joint car inspectors and car foremen, he can grasp many different ideas that will help to develop his mind so he can in the future fit himself for car foreman, or a chief joint car inspector, or perhaps a travelling car inspector, and even superintendent of the car department.—(*W. T. Clanton.*)



# SHOP PRACTICE

## GRINDING DRY PIPES

BY V. T. KROPIDLOWSKI

The grinding of steam and dry pipe joints is a big item of back shop expense. In a shop with an average output of 25 locomotives per month the pay roll of the steam pipe gang amounts to about \$400 a month. To be able to grind in fourteen sets of pipes in a month a gang of six men cannot meet with many bad joints. From these considerations it is evident that any means which can be devised that will facilitate the grinding of joints will effect considerable saving.

The illustration shows a device for grinding dry pipe joints on the front tube sheet, which is designed to be set up in the front end. The original crank used for grinding by hand is shown at *A*. The feed screw *B* and brace *C* are also part of

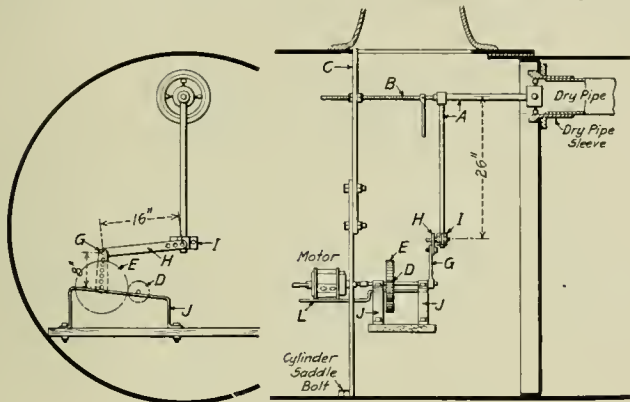

Motor Attachment for Grinding Dry Pipes

the hand equipment. A Little Giant No. 2 air motor furnishes the power, the speed being reduced two and one-half times by the gears *D* and *E*, from a motor speed of about 125 r.p.m. A Morse taper shank is welded on the end of the small gear shaft, to which the motor is attached. To the end of the large gear shaft a crank arm *G* is fitted. This is held in place by a set screw and imparts oscillating motion to the crank *A* through the link connection *H*.

The construction is simple and, therefore, inexpensive. The gears are of cast iron with 1¼-in. faces, the large one having a pitch diameter of 10½ in. and 106 teeth, the small one having a pitch diameter of 4 in. and 40 teeth. The gear shafts are 7/8 in. diameter, and run in small cast iron boxes, reclaimed from scrap and babbitted. The crank arm is made from a straight bar of merchant iron 5/8 in. by 1½ in., upset on one end for the shaft fit. A number of 9/16-in. holes drilled 1 in. apart permit the adjustment of the stroke. The link *H* is of 1/2-in. by 1½-in. bar iron, with three 9/16-in. holes for the adjustment necessitated by the difference in the diameters of front ends. The clamp *I* is made in two halves, one having a trunion welded on and finished, so that it will work smoothly in the holes of the link. The frame *J* is of 3/8-in. by 2-in. iron. The bar *L* is provided for the motor to rest on and can be removed at any time, as it is merely secured to the frame with eye bolts. The whole machine is mounted on a 2-in. by 12-in. plank, 4 ft. 3 in. long, and can be handled and moved about by one man.

Joints requiring from 10 to 12 hours by hand, with this machine can be done in one-half the time. This relation will not hold, however, as the time required by hand becomes less. Where a joint requires only four or five hours of hand grinding, with the machine it cannot be finished in two or two and one-half hours, because the time used in setting up, inspect-

ing and filing the joints, etc., is the same regardless of the amount of grinding to be done. The machine eliminates one man in many cases. Where the dry pipe is so hung that when pulled forward for inspection of the joint, the back end of the pipe is pulled out of the hanger, two men are needed, one in the dome to support the back end of the pipe every time it is pulled forward for inspection and filing of the soulder on the joint.

## WELDING HIGH SPEED STEEL TO SOFT STEEL SHANKS

BY H. W. HARRIS

The drawing shows a tool for use in lathes, planers or shapers, with a high speed steel cutting edge and soft steel shank. The welding is done in a forging machine, the high speed steel tip being welded on top of the shank so that it is backed up by the soft steel in the direction of the cutting strain.

The high speed steel tips are punched in the form of slugs by means of the punch and die shown in the illustration. Two small recesses or nicks are provided in the cutting edge of the punch, which cause the formation of slight fins on the slug. The soft

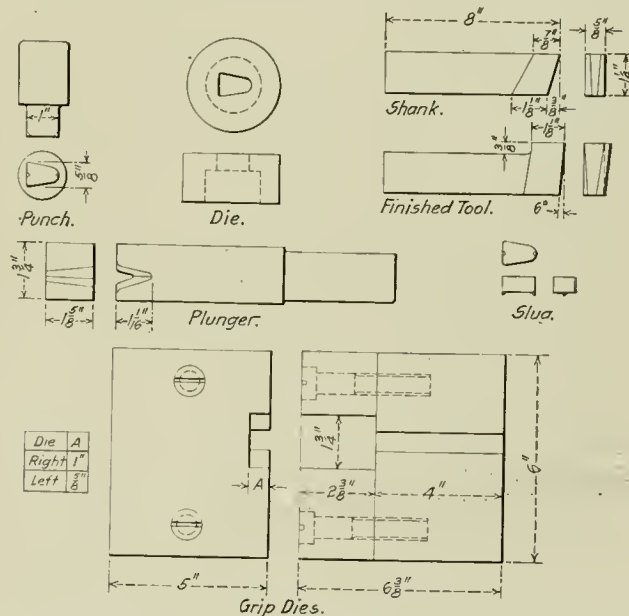

Forging Machine Dies for Welding High Speed Steel Slugs to Soft Steel Shanks

steel shank is tapered at the end to about the form of the slug. When a supply of shanks and slugs is ready the grip dies and plunger are applied to an Ajax forging machine, which is used to weld and finish the tools.

After the end of the shank has been raised to a welding temperature in an oil furnace it is covered with welding compound and the high speed steel slug applied to it. The slug is held in position by a light blow from a hand hammer which presses the fins into the hot metal. The two pieces of metal are again raised to a welding temperature and the tool inserted in the forging machine, where it is welded and finished with one stroke of the machine. When removed from the machine the tool is placed over an air blast and hardened, the flash being knocked off when cold. After grinding, the tool is ready for use.

This method of welding the two materials possesses three distinct advantages over hand welding. First, by making the

tools in quantities the cost of each tool is materially reduced by the use of the machine. Second, the pressure of the forging machine produces a dense, close grained tool. The last and most important advantage is the production of a better weld. Considerable difficulty has been encountered with the hand welded tools, the uncertainty of the welds resulting in frequent failures under heavy cuts.

### PISTON VALVE PACKING RINGS\*

BY JOHN C. MURDOCK

The most important feature of the piston valve ring is to have it steam tight. The steam and exhaust edges must be perfectly tight both at the beginning of admission, at the point of cut-off, beginning of release, and at the point where compression begins. The L-ring may be taken as a good example of mechanical construction of a ring that permits the free movement of the steam at the moment of admission and release. The L-ring, projecting out over the side of the groove, is sufficiently wide to cover the wall of the groove, thus permitting the free flow of steam and at the same time presents a steam tight edge square with cylinder wall. If the rectangular ring were used it may be seen that as the edge of the ring clears the steam port the flow would be obstructed or deflected by the wall of the ring groove.

The T-ring is a more elaborate development of the L-ring. The tendency of the L-ring is to show a lighter bearing at its thin edge on account of being backed up by less stock when it is sprung into its place. The T-ring overcomes this tendency. The Z-ring provides more in the nature of a plug fit and while this has some advantages it also has some disadvantages, as, for instance, with water in the cylinders it will take more pressure to pass the water by the rings. Taken as a whole, it is doubtful if any will show virtues enough to make up for the simplicity of the L-ring if it is properly made and maintained.

The packing rings at the steam edge of the valve give very little trouble from leakage, since the pressure of the steam is on them all the time and holds them firmly against the cylinder walls. The rings on the exhaust side are the ones that give the most trouble and interfere with the economy of the engine. From the steam distribution standpoint the economy in fuel is governed by the point of release and if the valve is properly constructed the packing rings that control the release must be maintained as tight as possible. At the moment of cut-off the steam ring, being in the port and surrounded or balanced in the steam, leaves all the work of holding the steam in the cylinder until it does its work by expansion, to the exhaust ring. Also the pressure from within the cylinder acts on the exposed part of the exhaust ring with a tendency to compress it and cause release to begin the moment enough of its area is exposed to the pressure in the cylinder to overbalance the exhaust pressure on the opposite side of the ring plus the spring tension of the ring.

The exhaust ring should be a perfect fit in the cylinder and never have less than 1/8-in. spring for a 12-in. diameter bushing. No expense should be spared in making this ring a proper fit, both in its groove and in the cylinder. After being split the ring should be closed and then turned to fit the bushing for which it is designed. Where this is not done the rings should be eased off with a file until they bear evenly all around the cylinder walls. Cents spent for this work will save dollars in fuel consumption.

The practice at the Allston shops of the Boston & Albany is to bore the 12-in. bushings twice, 12 3/32 in. and 12 3/16 in., respectively, before they are replaced by a new bushing. Where this practice is followed and the packing rings are expanded in the same ratio without expanding the followers of the piston

valve rings, trouble is experienced in the following two ways: the ring projecting into its groove 3/32 in. less all the way around in case of the 12 3/16 in. bore has less bearing in the groove and there is a greater chance for leakage of steam to occur laterally. The other trouble is the ring is liable to hang down so as to catch in the bushing and not go into the counterbore. For instance, given a 1/16 in. clearance around the follower and 1/8 in. spring in the ring in case of 12-in. bushing the ring hangs down below the riding ring 3/16 in. After the bushing is increased 3/16 in. in diameter the ring hangs 3/8 in. below riding ring. The idea to be brought out here is to have the ring sizes the same bore for 12 in.—12 3/32 in.—12 3/16 in. valve bushing making their depth of fit into the grooves constant and to increase their diameter by making the overlapping leg of the L thicker, i. e., no other dimension of the ring should be changed except the outside diameter of the rings and riding rings.

This would be of great benefit to men in engine house repairs, as many times the counterbore is small on the start and is never increased when bushings are bored. If you ever experienced the trouble of getting valves in on a hot summer day with a leaky throttle when the time is short you would know what this means.

### CHUCK FOR THE MANUFACTURE OF FLUE CUTTER BLADES

BY E. A. MURRAY

Master Mechanic, Chesapeake & Ohio, Clifton, Forge, Virginia

The illustration shows a device which has been employed very successfully at the Clifton Forge Shops of the Chesapeake & Ohio in the manufacture of flue cutter blades. Until a few years ago it was the practice, to buy flue cutter blades, but these blades gave very poor service due to breakage. It was finally decided to make the cutters in the shops, and a saving of nine

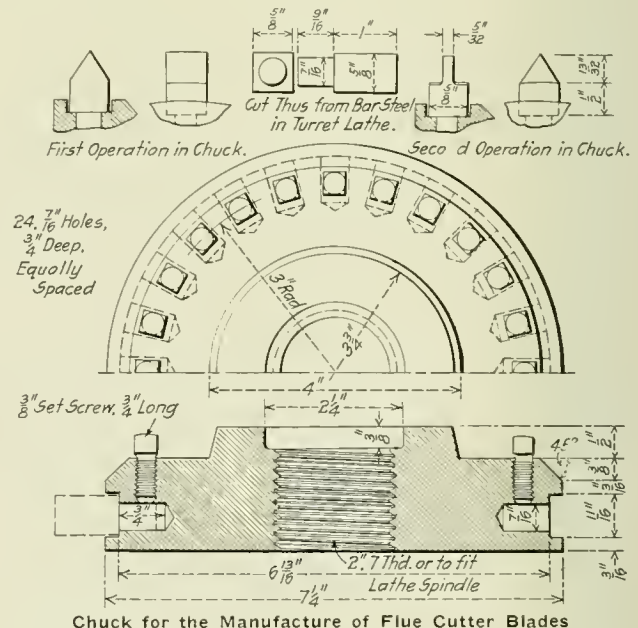

cents on each cutter has resulted with an increase of over 200 per cent in efficiency. The chuck was designed by W. C. Diebert, tool room foreman.

The cutter is made from a 5/8-in. square bar of high speed steel, which is turned and cut off in a turret lathe, as shown at the top of the illustration. These parts are then placed in the recesses in the rim of the chuck, where they are secured with set screws. The machining is done in two operations, the cutters each being revolved through an angle of 90 deg. in the recesses, after the first operation is completed. The chuck has a capacity of twenty-four cutters.

\* Entered in the Piston Valve Packing Ring Competition which closed October 1, 1915.

# THE SELECTION OF MACHINE TOOLS

Each Tool Must Be Studied Critically and Scientifically in Order to Secure Greatest Efficiency

BY GEORGE W. ARMSTRONG

The output of a shop and the economy effected in its operation depend primarily on the capacity of its machine tools. Ordinately the capacity hinges on the care exercised before a machine is purchased in ascertaining the character and amount of work which it is expected to perform, and the relation which its design factors bear in fitting it for the work intended. Simplicity is the prime factor and the other essential requirements are rigidity and accuracy.

The purchase of any machine tool should only be the result of a thorough canvass and analysis of its desirability and utility. Too often, the question of new equipment is determined from recommendations made by master mechanics, shop superintendents, etc. While it is desirable that the local supervision should be consulted in matters pertaining to their shop operations these recommendations are often apt to be colored by the desire to have facilities equal to that of the "other fellow"; by the desire to be well fortified with equipment to obviate possibility of falling down on shop output with its consequent trouble; or often because of the zealous importunings of machine tool salesmen.

The selection of suitable machine tools should involve not only a consideration of the initial cost, but also of its cost of operation and the design factors influencing the repairs and maintenance. Operating conditions will largely determine the size and type of machine, but where possible no machine tool should be selected unless sufficient work can be provided to keep it in continuous operation.

## COST OF MACHINE TOOL OPERATION

Interest on investment, including cost of machine tool, accessories and installation.

Depreciation on investment.

Cost of maintenance.

Power cost.

Wages of operative.

**Proportion**, based on floor space requirements, of the plant overhead, consisting of interest, taxes, maintenance, insurance, etc., on building.

Proportion of the supervisory and clerical cost.

It can readily be seen from the above factors that the hourly charge for a machine tool can be approximately as great whether the machine is idle or producing. Nor are these charges by any means imaginary, but rather tangible items entering into an actual cost appearing yearly in the accounts, and for which provisions are made in the Uniform Classification of Operating Expenses prescribed by the Interstate Commerce Commission.

The necessity will thus be recognized for selecting a machine tool which will be continuously operated and one requiring a minimum time for making speed and feed changes, and equipped with rapid set-up facilities. It is the desirability for maximum productive operation that recommends motor drive, gear box speed changes, push button control, the use of a vertical turret lathe or boring mill in preference to an engine lathe, or a horizontal milling machine in certain instances in preference to a planer.

Where the proposed machine tool installation is to be a replacement, the tool selected must be able to justify its existence; in other words, it must be able to show an earning or saving in the cost of operation based on the productive output as against the cost with the tools already in operation. As will be seen by consulting the table given above for cost of machine tool operation, this involves more than the labor costs. Frequently it would be possible to employ a tool of such size and capacity as to effect a 50 per cent, or even greater saving in labor cost, but it

would nevertheless be a very questionable economy; in fact, even an increased expense owing to lack of sufficient work to fully utilize the tool's capacity, or due to the extremely high fixed expense. For example, in a shop with an output of about 10 engines a month, having an 80-in. driving wheel lathe on which the cost of turning a pair of wheels was \$1.40, it would be a sheer waste to purchase a 90-in. motor-driven machine which could do the work for 50 cents a pair.

An expenditure, on the other hand, for a modern high duty radial drill press capable of effectively utilizing high speed drills would undoubtedly be fully warranted, as by its means a productivity of sufficient magnitude could be secured to replace two or more old-style machines. Yet this might still be unwarranted if the old machines are of ample construction and capable of being strengthened in feed mechanism and gear drive so as to utilize the capacity of high-speed steel.

In an initial installation, the prime influence of course is the necessity for certain machines to adequately cope with the work contemplated. The type of machine and the degree of development, other than that imposed by the work, should be the result of a careful analysis of the various characteristics (as outlined in the table of factors for consideration in machine tool operation) of the machine tools available. As far as possible, this analysis should be based on the manufacturer's specifications, supplemented by an actual observation of the machine tool in question under working conditions.

Cost Factors.	Investment	{ Initial cost of machine. Cost of accessories. Installation. Depreciation.
	Maintenance	{
	Operational	{ Hourly charge when idle. Hourly charge when running. Normal production per hour. Unit cost of production.
Design Factors.	Materials of Construction	{ Kind and quality used for different parts. Distribution of metal. Strength and stability of design.
	Power Drive	{ Belt, geared, motor or chain? Is the power ample? Is it positive or flexible, and which is best suited? Is control centralized and easily accessible? Are heavy parts power moved? Is mounting provided for direct motor drive?
	Speeds and Feeds	{ Are speed changes ample? Do they fit scheme of uniformity adopted for your shops? Are they in geometric progression? Can changes be quickly made?
	Bearings	{ Ordinary. Ball bearing. Roller bearing. Provision for taking up wear in major bearing.
	Lubrication	{ Forced? Sight feeds used? If not forced, are oil bores accessible? Oil or grease cups on bearings? Gears enclosed? Run in oil baths?
	Method of Chucking Work	{ Ordinary. Magnetic. Air controlled.
	Safety Provisions	{ For the operator. Of machine, i. e., foolproof safeguards.
	Operation	{ Frictional loss. Absence of vibration. Ease of feeding and discharging. Convenience of attachments.
	Repairs	{ Are wearing parts interchangeable, accessible and easily changed?
	Miscellaneous	{ Facility for quick set-up. Range of work possible. Is it easily movable? Arranged for use of cutting lubricants? Compact, yet not crowded? Fit location available?

In general the selection of a machine tool will resolve itself

into one of the following types as being those most commonly required in railroad practice:

- 1, Bolt threading machines.
- 2, Boring machines.
  - a, horizontal.
  - b, vertical.
- 3, Drilling machines.
  - a, heavy duty box-column type.
  - b, radial.
  - c, vertical.
  - d, sensitive.
- 4, Grinding machine.
  - a, cylindrical.
  - b, cutter and tool.
  - c, disc.
  - d, drill.
  - e, floor and bench.
  - f, internal.
  - g, surface.
- 5, Lathe.
  - a, engine or plain.
  - b, turret.
  - c, special, as wheel, etc.
- 6, Milling machine.
  - a, horizontal.
  - b, vertical.
  - c, universal.
- 7, Planing machine.
- 8, Shaping machine.
- 9, Slotting machine.

Brief consideration will be given the various types, their advantages and respective merits.

#### CONSIDERATION OF DIFFERENT TYPES

Two general types of bolt threading machines are in service, differing mainly in details of construction imposed by use of high speed and carbon steel dies. While the use of high speed steel must not be depreciated, as we owe to it our modern development of machine shop practice, it is questionable as to the advisability of employing it where any style of thread cutting tool is required. A full realization of the high speed elements in steel require tempering at approximately 2,200 deg. F. As this brings the steel almost to a state of fusion, it will be seen that if attained the points of the threads must be injured. To avoid this, a temperature of about 1,700 deg. to 1,800 deg. F. must be used, which renders it but little more effective than well tempered carbon steel. Particular attention should be paid in the threading machine to the construction of the die head, as the locking mechanism holding the dies in place while cutting, is of the utmost importance in securing an accurate, clean cut job.

Both types of boring mills are useful shop tools. The utility of a horizontal boring machine will be readily apparent for all classes of work requiring only boring and facing with no external turning, as it is capable of performing the work more effectively and quicker than an engine lathe or vertical machine.

Where work of any size requiring chucking is to be turned it is doubtful if any more effective machine can be selected than a vertical turret lathe or boring mill. With it quick set-ups can be secured, maximum rigidity of setting, quick tool changes and good cutting speeds. Particular attention should be given in boring machine selection to the manner of driving. Worm gear drive should be avoided, not only for these but for all types of machines, as it gives considerable trouble because of overheated and cut bearings and wears rapidly. Spur gear driven machines will be found far more satisfactory. A table, so constructed that it will not have a tendency to lift up with heavy cuts, is also to be desired.

All the types of drilling machines are to be found in railroad shops, the sensitive drill mainly only in tool rooms. By far the most satisfactory all-around machine is the high duty radial drill. This should be of rigid construction and with an arm so braced as to avoid springing under heavy feeds. This latter results in the drill dropping when emerging from the hole and is the cause of many broken drills. Variable speed motors are preferable in securing speed changes to a machine with either motor or belt drive and gear box changes.

Grinding machines are in service, but owing to their often complicated construction and limited use, it is doubtful whether other than for various tool grinding purposes their selection is justified.

Regarding the lathe, it is often debatable whether to purchase

a plain engine lathe or some type of turret lathe. Usually a powerful standard machine provided with quick speed and feed changes will turn out more work cheaper than an automatic or semi-automatic because:

1. The average machine job having few operations on it, rarely brings the special features of the semi-automatic into play.

2. In general, the number of pieces to be run through are too few to pay to set the stops, etc.

3. The machines are seldom properly equipped because each new job generally requires a complete outfit of special tools.

4. On account of these machines being more complicated than the average standard tools, some part is often out of order—not badly enough to pay for overhauling, but enough to interfere with the running.

Where work is to be done which is easily swung on centers an engine lathe is best adapted; while, as previously stated, the vertical turret lathe or boring mill is best adapted for all chucking work other than very small pieces.

The milling machine is a rapid producer as, owing to the greater area of cutter surface, higher speeds can be employed, cutting speeds of 70 to 90 feet per minute being not unusual. The horizontal milling machine also possesses the advantage that one piece can be machined while chucking or setting another, thus making the machining practically continuous. The horizontal machine is the ideal machine for heavy, fast cutting, as the strain comes straight down on the table. The vertical machine is best adapted to small and flat work. If the surface milled stands high above the table, the horizontal pressure of the cut throws a heavy strain on the chucking fixtures or clamping down bolts. High work also tends to lift the table from its bed and thus produces chatter. With the milling machine, particular attention should be paid to the size of the spindle, which should be at least one-third the diameter of the cutter head which it is desired to use. A substantial, rigid spindle is the most important factor in successful milling machine operation, as with a head and spindle that springs the feed will be only about one-quarter to one-fifth of that otherwise maintainable.

The planer, shaper and slotter are all so well known that little need be said regarding them. Owing to the variety and range of material, from chrome and vanadium steels to steel castings, and from cast iron to brass, a fertile field has been opened for variable speed motor-driven planers, of which there are several good ones available. Worm gear driven machines are to be avoided for the same reason as cited in connection with boring machines. As it is detrimental to maintenance of accurate surfacing to operate a planer to any considerable extent on short stroke, the class of work should receive serious consideration in the determination of the proper size.

#### GENERAL SUGGESTIONS

In conclusion, a few suggestions applicable to machine tools in general are given.

Lubrication should be well taken care of and be positive in cases of heavy machines. All high speed bearings should be equipped with ring type oilers.

The bearings, especially main, or others having considerable wear, should preferably be of a split type to facilitate taking up wear gradually. Certain types of tapered sleeve bushings are also useful, but do not permit of the latitude afforded by the split bushing.

Wherever possible avoid anything but spur gear driving and if necessary in high power transmission use heat treated gears. Avoid bevel gear drives as a source of constant trouble if you would have peace of mind regarding your machine.

For some heavy machines gears having teeth cut at an angle are to be recommended, as this prevents chatter and marking of works by the gear teeth. The power should pass through as few gears as possible from motor or belt cone to the work, and no gear should be required to run higher than 1,000 ft. per min.

of tooth speed. Above this, it is best to use belts or silent chain drive.

Machines equipped with bolt slots should have them designed so that the depth of the narrow part is at least 30 per cent greater than the width of the slot to prevent breaking of slots. It is important, too, that in service only bolts be used having specially machined heads so as to fully fill the slot.

And last, it should be borne in mind that the most salient points in machine tool selection are simplicity, accessibility, rigidity and accuracy and that the limiting factor in output should either be the tool or the strength of the piece machined after it has been set up to resist a heavy cut.

### OIL CANS OF RATIONAL DESIGN

Just why certain peculiar forms of oil cans are used by railroads is a question, when we consider the severe service to which they are subjected. Like many other things it is possibly due to lack of study and consideration on the part of those in charge of this work, or in the blind following of precedent. Some of the peculiar shapes in which they are made and the

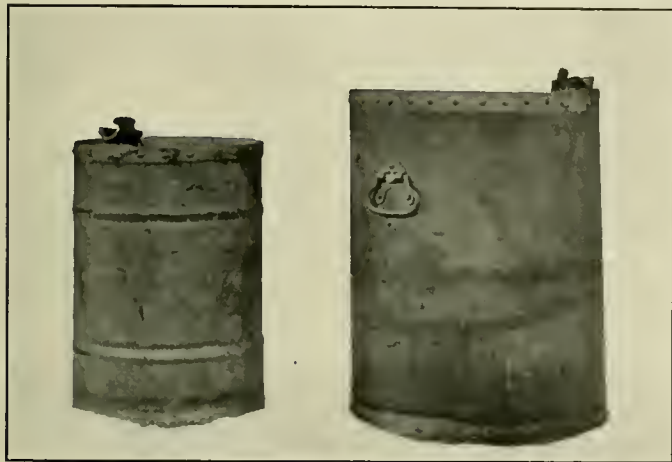

An Oil Can Designed to Withstand Severe Service

damage to which they are subjected is clearly shown in one of the photographs.

The second photograph shows a new design which was introduced on the St. Louis & San Francisco a couple of years ago and has given excellent service. The cans shown are of 5 and 10 gal. capacity, made of No. 16 galvanized iron. These



Poorly Designed Oil Cans Which Are Easily Injured and Require Considerable Storage Space

cans are made with flat tops and bottoms, flanged in  $\frac{3}{4}$  in. and riveted with rivets on  $1\frac{1}{4}$  in. centers. They are soldered in a large pot of melted solder, so that every rivet and seam is soldered at one time. The cans will stand a pressure of 40 lb. of air per sq. in. in testing them for leaks.

The 5-gal. cans cost \$1.65 and the 10-gal. cans \$2.00. The

cans may be rolled out of a car in unloading and not be damaged; in storing in the store department they will not take nearly as much floor space as other cans do. They will last indefinitely. The 5-gal. cans that were formerly used were made of No. 26 galvanized iron. They cost \$1.10 and the 10-gal. cans cost \$1.35; and they would not last more than about two or three months.

### POWER OPERATION OF RATCHET JACKS

BY ALLEN RAYMOND

Assistant Roundhouse Foreman, New York Central, Avila, Pa.

Raising an engine or tank with ratchet jacks is at best a slow and tedious operation. The workman is compelled to use up his energy in getting the engine off the rails and when he is ready to do the work for which the raising of the locomotive is but the preparation, he is tired out. The quality of the repair work done is therefore apt to suffer. The illustration shows a means by which this condition is reversed, the jacks being oper-

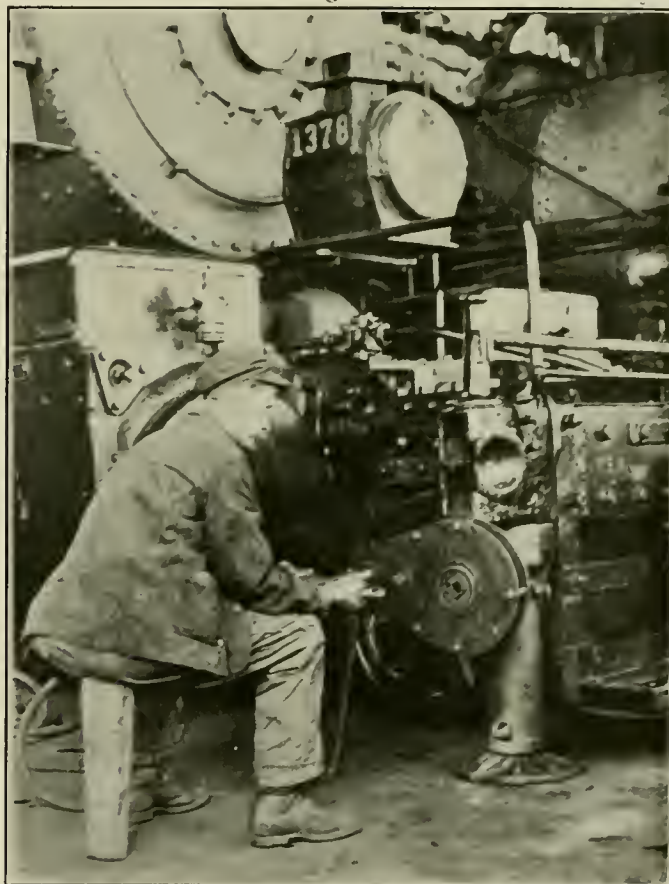

Operating a Motor Jack with an Air Motor

ated by an air motor which eliminates the heavy exertion from the raising of the engine.

The device consists of a simple double train of gears. The shafts of these gears are supported in a casing made up of two plates which may be maintained in proper relation to each other either by special bolts or straight bolts with thimble spreaders. The shaft of the small gear ends in a Morse No. 4 taper shank, to which any reversible air motor may be attached. The jack is operated from the shaft of the large gear, which is provided with a hexagonal socket. A  $\frac{7}{8}$ -in. eye-bolt is pivoted on one of the casing bolts at the motor end of the device. This bolt is 26 in. long and supports the device against the reaction from the motor torque.

With an air motor, using one of these reducing trains, a Norton ratchet jack may be operated about three times as fast as any

two men can operate it and it will lift a load that three men can only move with difficulty, using a 4-ft. jack handle. In addition to the ease with which heavy loads may be handled, this device facilitates operation in cramped positions where it is almost impossible to operate a jack by hand. No additional weight is added to the jacks to increase the difficulty of moving them into place as the gear trains are slipped on after the jacks are set.

Two of these gear trains are all that are needed, as they may readily be moved from one job to another. No expenditure other than the cost of the gears is required, as the devices may be used with old jacks.

### HELP THE APPRENTICE TO HELP HIMSELF\*

BY FRANK J. BORER

Foreman Air Brake Department, Central Railroad of New Jersey, Elizabethport, N. J.

My answer to your question, "How can I help the apprentice boys?" is, By helping them to help themselves.

Assume that I am an apprentice on the A. B. C. R. R. I want to become a skilled mechanic and if possible a foreman, or even a master mechanic. To attain my goal I must put myself in shape to be worthy of the efforts of my instructors and foreman. I must think more of my work than I do of baseball, the movies and other diversions. I must come to the shop with an enthusiasm and ambition to learn and to work. I must concentrate my mind to obtain knowledge, since knowledge is power and ignorance impotence. To be a good apprentice I find it is necessary to have a fairly good education—the more the better.

Having the proper qualifications my future progress as an apprentice depends almost entirely on the effort the company makes in my behalf.

I consider it of the utmost importance that we be given regular classroom instructions in drawing and arithmetic and special or individual instruction relative to the particular class of work we are performing in the shop. For instance, if we are apprentices in the locomotive erecting shop we should be given instructions in valve motion, and apprentices in the car department should receive instructions in the M. C. B. rules and safety appliances. To assure a standard of method and regularity, a special instructor working in co-operation with the foreman should have charge. We apprentices should then be subject to a thorough system of checking and examination to ascertain our progress, characteristics, special traits or talent, deficiencies, etc.

To obtain the best results our instructors should have a keen insight into human nature. They should appeal to our self-interest to create a healthful rivalry between us to excel one another and promote us according to merit. This will act as an incentive to put forth our best efforts. While some of us have executive ability and crave for responsibility, others shirk it, but have genius or initiative in its stead. We all strive, however, for one common object—a well-paid, steady position according to our ability.

The mutuality of interests between us and the company should express itself in our work. On the other hand, the foreman should always treat us kindly but firmly. He should never swear at us. Neither should he expect too much of us at the beginning. If he puts us to work with a mechanic, he should pick out a good man and not a John Barleycorn or Jack Good-enough. He should look at the apprenticeship system from an altruistic as well as an investment-business point of view; something that will bring large returns if properly handled. If the foreman succeeds in building up a force of good, loyal young mechanics as the years roll by, he has rendered the country at large as great a service as its best teachers, artists and the professional men.

\* Entered in the competition on "How Can I Help the Apprentice?" which closed September 1, 1915.

### LAYING OUT ECCENTRIC KEYWAYS

BY R. S. MOUNCE

It is generally considered impossible accurately to lay out eccentric keyways in Stephenson link motion, it usually being necessary to properly adjust the eccentrics by means of offset keys. But by following the method here set forth the writer has found it possible to use at least three straight keys with the fourth not more than 1/32 in. out of true. It should be noted, however, that these results can only be obtained by great care in securing an accurate layout.

The center line of the valve motion in relation to the crank pin must first be determined. This can usually be determined from the general drawing of the locomotive and should be laid out to half-size or full-size scale, as shown in Fig. 1. Lay out point *a* on the main axle with a box square and from *a* lay off the distance *ab* with a pair of dividers. Then draw a line half way across the axle through the point *b*. This is the line from which the eccentric keyways are to be laid off. In a similar manner draw a corresponding line on the opposite half of the axle.

Assuming a slide valve, and that both arms of the rocker are of the same length, *AD* in Fig. 2 represents the center line of

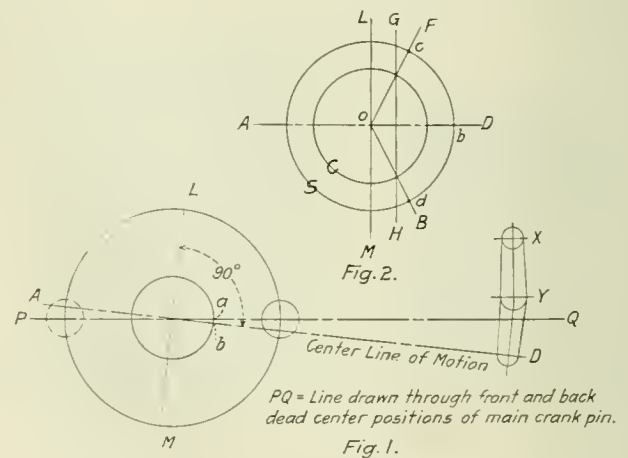

An Accurate Method of Laying Out Eccentric Keyways

the motion. *LM* is drawn perpendicular to *AD*. Draw *GH* parallel to *LM* at a distance from it equal to one-half the total outside lap of the valve, plus the lead. Draw the circle *C* with a diameter equal to the throw of the eccentric, and the circle *S* with a diameter equal to the eccentric bearing on the main axle. Draw the lines *OF* and *OB* intersecting *GH* on the circle *C*. The points *c* and *d*, where these lines intersect the circle *S*, indicate the location of the centers of the eccentric keyways on the axle and should be laid off from the line drawn on the axle through the point *b*, with dividers set for the distance *bc* and *bd*, which are equal.

If the arms of the rocker are of unequal length, the distance between the lines *GH* and *KL* will be the lap plus the lead multiplied by the ratio of the lower arm to upper arm.

**FRENCH FUEL BINDER.**—A fuel binder recently patented by a French maker, which is fusible to a vitreous mass at 200 deg. Cent., consists of 15 parts of glassmaker's sand, 18 parts of Portland cement, and 10 parts of carbonate of soda or other flux for silica, such as sea salt or sulphate of soda. Dry fuel dust, such as coal in grains up to 5 mm. in size, is mixed with from 4 to 6 per cent of the mixed binding ingredients, the product, with the addition of 8 per cent of water, being compounded in a mixer to which steam under 8 kilos. pressure, at 170 deg. Cent., is admitted, the mass subsequently being pressed into briquettes. Heat may be applied to the material issuing from the press to increase the cohesion.— *Engineer (London)*.

# BETTER LOCOMOTIVE BOILER INSPECTION

Five of the Articles That Were Submitted in the Competition\* Which Closed November 1, 1915

BY W. H. SAGSTETTER

Master Mechanic, Kansas City Southern, Shreveport, La.

One of the most annoying incidents in the mechanical department is the tying up of a locomotive by a federal boiler inspector. This can be easily overcome by an efficient and proper organization. Each railroad and each division thereon must have a system of boiler inspection that fully complies with the federal law and is at the same time efficient.

The first and most essential thing is to have a practical boiler inspector, one who has plenty of good common sense, and who is thoroughly familiar with all rules governing the inspection and maintenance of locomotive boilers and their appurtenances.

The boiler inspector must be able to operate and inspect all appliances that come under the regulations and to see that they comply strictly with such regulations; he must be able to make proper and intelligent reports, and his ability must be such as to leave no doubt in the minds of his superior officers that the reports are accurate; he must not be easily swayed by minor officers, or even by his superior officers, and must assume no responsibility that he would not assume were he in their place; he must be invested with the same power as a federal inspector and his reports should be given the same consideration as those of the federal inspector; he should at all times have access to all records, so that he may keep posted as to the requirements of each individual locomotive on his division and should, further, have his own file of boiler inspection reports for ready reference.

To have an inspector who is not familiar with the rules is as bad as having none at all. A competent man must be able to make a hammer test of staybolts, to examine fire sheets for cracks, to measure the depth of a telltale hole and to operate gage cocks, injectors and water glass cocks. He should also be able to ascertain whether or not a pop is properly regulated and to see that all boiler forms are properly filled out according to instructions. The inspector should have no hesitancy in calling the attention of the various foremen, or the master mechanic, to a defective boiler or its appurtenances and should insist on such parts being repaired before he signs the reports in the presence of the notary public.

The foremen at division points are too prone to neglect small things that conflict with the laws, and that should be repaired before engines are allowed to depart from the terminals, and unless the boiler inspectors are very strict they will be persuaded to allow engines to make one or more trips before such work is taken care of—and in all probability, within one or two trips, the engine will cause an accident or be found in defective condition by the federal inspector.

The old adage, "A stitch in time saves nine," has proved to be very true as applied to boilers. It will be found that if a staybolt is removed as soon as it is found broken, instead of allowing it to run, probably causing the breakage of adjacent bolts, time will be saved in the end. Where one bolt can be renewed in one hour it is oftentimes necessary to hold an engine for a day to renew six or eight.

The co-operation of the master mechanic and division foreman with the boiler inspector is essential, and on the first day of each month the chief clerk of the master mechanic should send out to the boiler inspector, and all division foremen, a statement giving a list of locomotives that are due to receive attention during the month, as to hydrostatic test, removal of caps from

\* The prize article and one other were published in the December, 1915, issue, page 635. The annual report of the Chief Inspector of Locomotive Boilers to the Interstate Commerce Commission was published in abstract in our January issue, page 41.

flexible bolts, etc. Opposite the engine number should be shown the date on which such work is due; this information gives the roundhouse foreman an opportunity to arrange for such heavy repair work as may be necessary on the engine at the time the boiler work is done.

The form illustrates a complete five-year record of a locomotive. This record should be kept in the office of the master mechanic so that correct information can be furnished relative

The Kansas City Southern Railway Co.												
											Form M. P. 107	
											Number 491	
											Locomotive Initial KCS	
	July	August	September	October	November	December	January	February	March	April	May	June
1911-12	28	18	19	14	9	29	23	20	31	16	20	19
1912-13	20	20	20	29	27	20	31	7	31	5	5	18
1913-14	18	25	29	2	20	25	27	26	23	25	30	30
1914-15	15	31	6	9	30	21	8	8	11	16	16	6
1915-16	7	12										
Hydrostatic Test Period—One Year			Flexible Stay Bolt Caps Removed Period—12 Months			Flues Removed Period—Three Years			Lagging Removed Period—Five Years			
Apr. 16th., 1912			Apr. 5th., 1913			Apr. 16th., 1912			April, 5th., 1913			
Apr. 5th., 1913			Oct. 9th., 1914			Apr. 5th., 1913			Dec. 21st., 1914			
Mar. 23rd., 1914			Dec. 21st., 1914			Dec. 21st., 1914						
Dec. 21st., 1914												
Remarks: New Firebox applied Dec. 21st., 1914.												
All new flexibles applied Dec. 21st., 1914.												

Underscored figures are red in original and indicate date of hydrostatic test

## Five-Year Record of Locomotive Boiler Inspection

to hydrostatic test, etc., and should at all times be open to the boiler inspector, boiler shop foreman, and others concerned. The date of the hydrostatic test should be inserted in red,\* and the remainder of the information in black ink; by so doing the date of last test is easily ascertained.

I believe that if the shop boiler inspector is allowed the same authority as the federal inspector, especially as to condemning a boiler when it does not come within the requirements of the law, and such rule is enforced, there will be more effort made by the roundhouse forces to see that all small defects are taken care of as soon as reported, thus avoiding criticism by the government inspectors.

BY FRED CHINNOCK

Boiler Inspector, Grand Rapids & Indiana, Grand Rapids, Mich.

A locomotive boiler inspector should be a practical boiler maker, thoroughly familiar with the construction, repairing and operation of locomotive boilers. He should be able to find the safe working pressure of a boiler in all its details and determine as to whether or not it is in a safe condition to carry the load under which it operates. He should also be familiar with the federal laws covering locomotive boilers and their appurtenances.

Filing cabinets, desk room and stationery should be furnished for filing copies of the federal reports and keeping records of washouts, steam gage tests, hydrostatic tests, flexible staybolt examinations, etc.

In making an inspection of a locomotive boiler, the firebox should be examined for broken staybolts and crown stays, defective flues and arch tubes, laminations, mud blisters, cracks and leaks. The outside should be examined for leaks, broken staybolts, defective washout plugs and defective arch tubes. The

\* The underscored figures in the illustration were in red ink.

boiler should be properly washed, and the gage and water glass cocks and arch tubes cleaned. The steam gage test, hydrostatic test, or flexible staybolt examination, should be made at this time, if due during the month. All defects should be repaired and proper reports filed with the district inspector. Should a hydrostatic test be necessary an internal inspection should also be made.

A boiler inspector should not be overburdened with such work as inspecting ash pans, grates, nettings, front ends and other locomotive running repairs. The federal law should be amended so as to require flexible crown stays, or stays made of hollow iron, to be used in wagon top boilers, as it is impossible to detect all the defective crown stays with a hammer test in boilers of this type.

BY R. S. LEE

General Foreman, Stroudsburg, Pa., Shops, New York, Susquehanna & Western

A boiler inspector should have a fair education to enable him to keep his records in proper condition; read blue prints, and make out certificates and reports. He must be alert, observing, temperate, have a good memory, an even disposition, and a personality that will command respect.

After a boiler has jacket, lagging, flues, etc., removed and is thoroughly scaled and cleaned, he should make a thorough inspection, carefully noting any evidence of cracks, pitting, grooving, corrosion, and deposits of scale on crown sheets. All braces and stays should be examined to see that they are under proper strain, are of right dimensions, free from cracks and sufficient in number. All staybolts should be tested, and all evidence of steam or water leaks noted and taken up with proper officer. After his report is made he should check up to see that his recommendations are acted upon and the work properly done; to do this he must receive the support of every supervising officer. He must be familiar with all the requirements and in all cases his authority must be respected.

In order to facilitate his work he should be provided with a desk and filing boxes in the office of the foreman boilermaker so that any matters between them may be handled with despatch. Where electricity is used a small electric lamp designed to be inserted in washout holes is of great value in examining the crown sheet, front and back ends of mud ring, etc. This light should be located at the end of a piece of  $\frac{3}{8}$ -in. pipe, which serves as a handle and covering for the wire, and should be long enough to reach from the back head to the front of the crown sheet; the bulb should be protected by a shield at the end.

BY A. MacCORKINDALE

Foreman, Meadows Shops, Pennsylvania Railroad, Jersey City, N. J.

It is a matter of close supervision by the motive power departments to see that all tools are in first-class shape; also all boiler work done must be reported and immediately filed so that every engine may be checked in every detail of boiler inspection. Copies should also be filed in every division roundhouse to which the engine is assigned. Our experience has shown this to be very valuable where a certificate happened to be lost out of the cab, or a boilerwash or staybolt tag gone. A telephone message to the division roundhouse night or day from other division or interdivisional points, such as Philadelphia, Washington or Harrisburg, concerning boiler inspection, brings the necessary data and no delay is ever caused on that account. This filing system is always under the eye of the boiler inspector.

May we offer the following advice: "Follow instructions;" "Assure yourself that everything is as ordered before taking an affidavit;" "Don't forget that the reputation of the corporation you work for is shared with you and if the unforeseen failure happens involving legal proceedings the evidence of the boiler inspector looms high."

BY T. E. TOOHEY

Boiler Foreman, Union Pacific, Evanston, Wyo.

On the last of each month we make out a form, listing

locomotives in numerical order, and showing each individual engine under our care for the next month. It shows which are due for test of safety valves and steam gages, change of flues, hydrostatic test, caps to be removed from flexible staybolts, etc. This is put in a convenient place, so that the boiler foreman and boiler inspector may have access to it at all times. Each morning it is studied to see what is to be done in the next 24 hours.

In addition to this we have a form listing engines in numerical order; when inspection is made and report is filed, we mark date that inspection report was filed opposite engine number. By so doing, we always have at hand data as to what inspections have been made, and date that inspections were made. We never duplicate any reports, thus causing unnecessary work.

The boiler foreman has a special book which shows for every engine under his care, the date the firebox was applied, date of last hydrostatic test, date safety valves and steam gages were tested and pops set, date caps were removed from flexible staybolts, date flues were last changed, months engine was out of service (if any) to take advantage of the automatic extension we are entitled for hydrostatic test, removal of flues, etc.

As regards monthly I. C. C. boiler inspection reports, Form No. 1, and annual I. C. C. boiler inspection reports, Form No. 3, we have a separate file for each in a convenient place. When inspections are made and the forms are made out a copy is placed on file and the copy for the previous month or year is removed and filed for future reference.

After the boiler inspector has made all necessary inspections, and has seen that all defects he has reported have been repaired, he makes out his monthly I. C. C. Form No. 1, or the annual I. C. C. boiler Form No. 3, as the case may be. The forms are then placed on the boiler foreman's desk, who checks against them from his special book, and from the previous month's or year's report, which is on file. Any mistakes he finds are corrected and the forms are forwarded to headquarters at Omaha.

We have plenty of office room and desk room and our superior officers are always willing to give us any facilities we may ask for that will help in any way to make our work more effective.

#### DETAILS OF INSPECTION

Each morning the boiler inspector receives from the boiler foreman a list of locomotive boilers to be washed out during the next 24 hours. If any of the boilers on this list are due for an inspection, he makes it after the boiler is blown off, inspecting all firebox sheets, flues, testing staybolts, etc. If he finds any defects, he reports them immediately to the boiler foreman. He then sees that necessary repairs are made. If the engine is due for test of steam gage, and the safety valves are to be set, this work is done.

If the engine is due for hydrostatic test, we remove the pops and place caps over the pop holes, also putting a gage on the turret dome, in addition to the regular boiler gage. We have the lagging and jacket removed from over the staybolts, and use a La Rue ejector for getting the required pressure on the boiler. The steam gages are tested before applying pressure to the boiler. The dome cap and throttle box are removed after the test, and the interior of the boiler is inspected above the flues. If any defects are found while testing the boiler, such as leaks in any part, broken stay bolts, etc., the necessary repairs are made before the engine goes into service.

In addition the boiler inspector examines telltale holes in staybolts in all engines in the roundhouse each day to see that they are open and of the required depth. He also examines for steam leaks and other defects that may show up while the engine is under steam pressure.

The boiler foreman has a form to keep records of boilers washed; the engines are shown in numerical order, and each morning he lists those that have had their boilers washed out during the preceding 24 hours. After the boiler is washed out it is examined through the washout plug holes to see that no mud or scale is left inside. All washout plugs are inspected, as well



as threads in washout plug holes, to see that they are in good condition.

When any broken staybolts are renewed the exact location is marked on a Union Pacific staybolt chart, and at the end of the month they are reported on separate charts for each engine. In addition all patches applied, flues changed, plugs applied to cracks in firebox, new cracks developed in sheets, etc., as well as estimated life of firebox, and condition of flues, are reported on this staybolt chart.

In addition the boiler foreman is also on the job looking for defects in locomotive boilers under his care. He also has a standing order to boilermakers doing running work, both day and night, to report to him any defects that may be found. We find by doing the jobs as soon as possible and keeping our work up, we get the very best results, and our power is always in good condition.

At Evanston we are always glad to have government boiler inspectors visit us, and inspect our boilers. They always have some good suggestions as to the way boiler work is done at other places and are willing to give us these ideas. We are also glad to furnish them any new kinks or schemes that we may have.

## TONING UP AN ORGANIZATION

The three prize-winning letters submitted in the contest to secure practical suggestions for "Toning Up an Organization" are given below. This contest closed January 1, 1916.

### EFFICIENCY MEETINGS

BY J. A. PACK

Chief Clerk, Motive Power Department, Chesapeake & Ohio,  
Huntington, W. Va., Shops

It has been the practice at Huntington shops for several years to call the foremen of the different departments together in semi-monthly efficiency meetings, a regular organization being effected with a chairman and secretary. At these meetings the progress of the work and suggestions for the improvement of methods and working conditions are freely discussed. This results in better coöperation and team-work.

The shop superintendent and general foremen are able to smooth out differences and misunderstandings which occasionally arise, bringing all together in a general discussion and harmonizing the entire force. By having these efficiency meetings at certain periods, the shop superintendent and the foremen become well acquainted with each other in a way that cannot be done when they merely meet in the ordinary course of their duties, one or two at a time. Here they gain an insight into each other's mentality and sympathy. It is conceded that mind is the source of all action, that loss in efficiency is the result of wrong thinking, and such loss can be corrected by establishing a system that will tend to eliminate wrong thinking. The wrong thinker is the wrong doer and a wrong act is always produced by a wrong thought. Many think incorrectly and are so self-satisfied that they believe they are correct. It should be remembered that faith in your fellow men is requisite to co-operation, and that the spirit of driving has long since ceased to be a virtue.

The chairman of the efficiency meetings always endeavors to teach that all operations correctly performed are based on right thinking. No man can think correctly and have a clear mentality unless a great effort is put forth to eliminate from his consciousness self-satisfaction, self-esteem, envy, hatred, anger, jealousy, resentment and fear. As coöperation between the foremen, and also between the foremen and men is an absolute necessity, it would be well for each foreman to thoroughly understand how coöperation can be secured and maintained.

The foreman should always be ready and willing to listen to suggestions made by his men and encourage suggestions, as the entire plant is made up of mental force, and by soliciting suggestions from the men he will have coöperation; whereas, on the other hand, by rebuking an employee or failing to listen to his

suggestions, a resentment is set up. This, being opposed to right thinking, cannot result in a harmonious organization.

## ENCOURAGE SUGGESTIONS FROM THE MEN

BY JOHN V. LE COMPTE

Foreman, Motive Power Department, Baltimore & Ohio, Baltimore, Md.

A perfect organization should have at its head a man of discretion and knowledge, a man with ability and personality, a man whose orders must be carried out and who is a natural born leader. The results, as well as the success of the organization, depend largely on the head and his assistants. Although the personnel of the organization may be the best that can be secured, the good results which might obtain can be neutralized by improper leadership.

The success of this organization depends largely on harmony, backed by the spirit to accomplish effective results. This harmony can be and has been intensified by bringing in contact on a business basis the foremen and assistants of the various departments. Meetings of this character have been conducted with favorable results, thus bringing in contact men whose experience has been broadened by holding supervising positions.

The spirit of Ego should not characterize the head of the staff or his assistants in these deliberations for the good of the service, but rather the spirit of "we are one of you."

Meetings of the staff can be almost non-productive because of the above spirit being evident, and a throttle thereby put on an otherwise free discussion of means and methods, which no doubt could produce results.

What the staff is to the organization as a whole, the shop meeting can be to each department. Each foreman, assistant, gang leader, apprentice instructor, piece work inspector and clerk, together with each employee, should be made to feel that he is a vital part in the organization by which he is employed.

The proper spirit of coöperation cannot be obtained unless square dealings characterize the attitude of the supervising staff toward the employees of the several departments. Confidence must be obtained, sincerity and honesty must characterize every act, that the foundation for results may be laid on a basis born of square dealings.

I have been one to aid in the establishing of the above conditions, have seen them develop and ripen, until the very helpers of the department who have swept the shops and carried out the cuttings have come to me with suggestions for the good of the service. What has been true of the helpers has also been true of the handy men and mechanics. The spirit of freedom to address the foreman opens the way for each one to deal with his particular line of work whether machine, vise, floor or erecting. Coming in direct contact each day with the several lines of work that they handle they become more familiar with each part than any supervising officer can be, and thereby develop ideas regarding the handling of it, that if accepted prove a saving factor in the output of the department.

Other methods have been employed, such as a suggestion box, etc., the same being placed at the office door to receive any suggestions from the employees. This is a good means to employ, but the best results to be obtained in any line, can only be accomplished by the manifestation of those noble characteristics that beget confidence from the head of the staff down to the most humble position in the service, this being backed by honesty and square dealing. When this spirit is manifested and the methods as above outlined put in practice, tangible results will be obtained.

## DRAWING ROOM TONIC

BY MILLARD J. COX

Asst. Supt. Machinery, Louisville & Nashville, Louisville, Ky.

A drawing room that deserves the name should be ahead of the shop and continually in the lead as a bureau of information; otherwise it may as well be called the "copying" room.

When a draftsman, for relief, I often sought the shop, running intentionally into some bright mechanic for a brief new

thought. One of my favorites was an old English machinist who gave me many a helpful tip. They were old to him, I've no doubt, but they were brand new to me. I was a frequent visitor to his bench. Valve gear, condensers and high-class stationary engines were his hobbies. A pattern-maker friend was a great mathematician, and when in the humor for this kind of recreation, I found him always ready with a new "nut to crack." Complicated cylinder designs and propeller blades were his special diet, with algebra and geometry for dessert. A boiler maker man was fat, grouchy, and as rough as pig iron, but much alive to the interesting problems concerning scientific boiler laying out, staying, strength of materials, machine against hand work, and costs. These geniuses, all brilliant mechanics of the old school, have passed away, but their stimulating influence is at work, and still furnishes some inspiration for these exacting times and conditions.

Next to having a real genius for the head of the drawing room, I know of nothing that brightens the wits and sharpens the mechanical appetite more than to have a small modern library accessible to the men and boys, and a reading table on which the leading scientific and mechanical journals are to be found. This store of knowledge should be in a conspicuous place, and some one in charge to see to it that these valuable tools are always in order according to dates. The most striking articles should be marked, and later on clipped and added to their proper groups in the files or scrapbooks. The next thing to having the information in mind is knowing where to lay hands on it instantly. To follow out this scheme systematically, have the names of all the men pasted on the back covers, and require them to check the dates opposite their names when they finish reading. There is no objection to taking the papers home at night. The majority will respond to this, if your experience is anything like mine.

Invite the bright fellows to write articles occasionally for publication, and encourage all ideas of merit. Volunteer your service as a friendly critic. A good, stiff problem, requiring research, will stir up the younger ones, and cause the older ones to take notice.

Draftsmen should make opportunities to visit the shops frequently to study the various operations. If our architects and draftsmen would get out and see their designs actually in use, and note what a mess they make sometimes, the shock would do much toward improving their mechanical ambition, provided they are not hampered by a too great opinion of their importance.

Another good tonic is to take the opposite view from your designers, as if you were in earnest about it, and in this way draw out all the points until the subject is threadbare. When you unexpectedly do this several times, your right-hand men will find out you are not to be satisfied with a single idea, and they will furnish a greater variety in the future from which to select.

The main difference in men is their way of thinking. Furnish your force sound leading thoughts, good mechanical ideas and helpful literature. It will always prove a worthy investment, and one that will always tend to tone up effectively the entire personnel.

**SLUSHING COMPOUNDS.**—These compounds often fail to accomplish their purpose fully owing to the low melting points of the greases used. In oversea shipments where transportation through warm climates is involved the greases are apt to become fluid and the unprotected metal is then attacked. To remove this possibility, some shippers have reverted to the old white-lead and tallow coating. This is mixed with 4 lb. of tallow to 1 lb. of white lead, the latter being stirred into the melted tallow. This mixture affords an excellent protection against rust, but because of the acid in the tallow it should be removed at the earliest opportunity. For this purpose kerosene or turpentine will be found effective.—*American Machinist*.

## NOTES ON THE BUTTON-HEAD RADIAL STAY

BY JOSEPH SMITH  
Lorain, Ohio

The button-head radial stay plays an important part in the construction of the modern locomotive boiler, and as such it should be given as much care in the applying and upkeep as any other part; yet how often do we find, when calking becomes necessary, that the tool is held as shown in Fig. 1; it does not take many such calkings to make it resemble a door-knob.

Where care is exercised and the tool held as shown in Fig. 2 the life of the bolt-head is prolonged and further leakage avoided, provided the crown-sheet is not muddy and the bolt has been properly applied in the first place. By being properly applied, I mean that it should have a snug fit, but not so tight that it requires a wrench 60 in. long and the pulling power of two men to screw it up to the sheet. By so doing you are only crushing the thread and paving the way for leaky bolts.

Sometimes the heads fall off. Some claim that crystallization

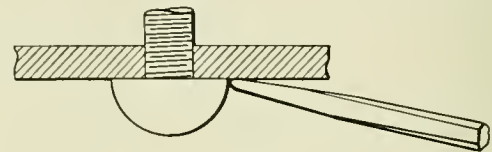

Fig. 1

has set in and it only requires a few blows of the calking tool to knock the heads off. To a certain extent this may be true, but the appearance of some of these heads leads me to believe

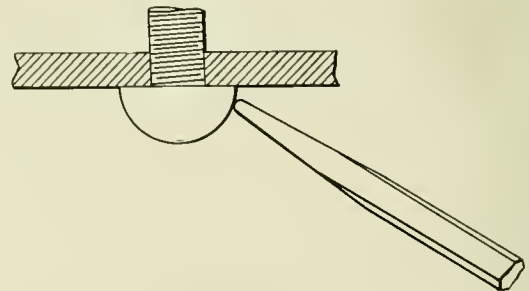

Fig. 2

that possibly there is another reason. In the forging of the bolt the metal has to be upset and crushed into shape between dies whilst hot. It may be that some are not heated to the point

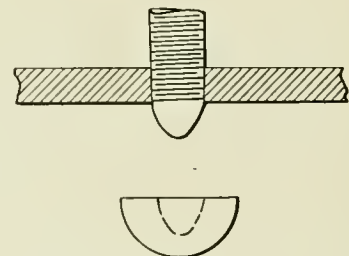

Fig. 3

necessary to form the head into a perfectly homogeneous mass. My meaning will be more clear by noting Fig. 3; the head when it comes off is usually cup-shaped, which leads me to the line of reasoning I advance.

**COMPLEX ALLOY STEEL.**—In a paper on alloy steels, which formed a part of a symposium presented before the International Engineering Congress, it was pointed out that practically none of the constructional steels contain three or more alloy metals. The only steel in this class to be considered is what is commonly known as high-speed steel.—*American Machinist*.

# APPRENTICES ON THE SOUTHERN PACIFIC\*

## A Great Advance Made in the Methods of Instruction and Training Employed on That System

BY THOMAS G. GRAY  
Apprentice Instructor

The first apprentice school on the Southern Pacific was started in the fall of 1911 at the West Oakland (Cal.) shops. A year later the management decided to extend educational opportunities to the apprentices at all of the division and general shops on the system. Classes of apprentices were organized at the three largest shops—Sacramento, Cal.; Los Angeles, Cal., and Sparks, Nev.—on January 1, 1913. Since that time schools have been started at San Francisco, Cal.; Dunsmuir, Cal.; Brooklyn, Ore., and Ogden, Utah, making a total of eight apprentice schools now in operation on the system with an enrollment of 450 apprentices.

### INSTRUCTORS TAKEN FROM THE SERVICE

The work of organizing and conducting these schools was, with but one exception, placed in the hands of men taken from the service, either draftsmen or mechanics of unusual training. Some of these men are college graduates and all of them are experienced in shop work.

In entering on such a new field of work as the organizing of apprentice schools, these men were at once impressed with the need for some available source of information from which to draw for guidance and help. Such a source is now being supplied through the admirable work of The National Association of Corporation Schools. Valuable help was obtained from articles published in the various railroad journals during the past few years and the fruit of much experience was cordially and generously given by leaders in educational work on the roads which have pioneered in this movement.

Upon the establishment of the earlier schools on the Southern Pacific each instructor worked out courses of instruction according to his own ideas, learning by experience as he progressed. In January, 1914, a meeting of Southern Pacific apprentice instructors was held at Reno, Nev., as a part of a safety conference under the auspices of the University of Nevada. At this conference two vital needs for the development of the work were set forth in a recommendation to the management—first, that the work of training apprentices be organized under a central head, and, second, that standard courses of instruction be compiled.

### HOW THE SCHOOL WAS INSTITUTED

Early in July, 1914, the work of compiling courses of instruction for the various trades was started and two months later a meeting of the instructors was held at Sacramento to go over the work outlined and to adopt standard courses from the combined ideas of all. Rules governing the employment and training of apprentices, including schedules of shop experience, were also adopted at this meeting. These rules received the approval of the management and were put into effect February 1, 1915. The standard instruction courses were approved by the management and put into general use on September 1, 1915.

In compiling the standard instruction courses a general plan was followed, which, it is felt, answers in a practical and thorough way the needs of the shop apprentice as he progresses.

### THE PLAN OUTLINED

The following outline of this general plan will be of interest, and it is hoped that it may prove helpful to those who are undertaking the compiling of courses.

*First:* A general problem course to be completed by every apprentice entering the schools. This course includes instruction in all the principles of arithmetic from simple addition through ratio and proportion, the more common applications of mensuration and simple problems involving applications of the elementary principles of mechanics. In general the type of problem included in this course is the general railroad problem and not that pertaining to the work of a specific trade. This latter type of problem is included in the specific trade course which will be explained later. The need for a general problem course covering a complete review of arithmetic, as a foundation for apprentice instruction, will be readily conceded by all who have had sufficient experience to realize the general deficiency of grammar school graduates in this most important subject.

*Second:* A general introductory course in geometrical and mechanical drawing to be completed by every apprentice and to be carried on simultaneously with the general problem course; that is, an apprentice to work for one hour of his two hour period on the problem course, and one hour on the introductory course in drawing. This course is simply an introductory course and nothing more. Its purpose is not to teach geometrical and mechanical drawing, but simply to set forth in a clear and thorough way, those principles of drawing which must be applied later in the making of sketches. A mechanic to make a clear, understandable sketch must know the principles of drawing; he must know how to place the views, and it is the purpose of this course to explain and apply such fundamental principles of drawing as are used in the making of a good, clear sketch. The geometrical problems included in this course are those most likely to be of service to a mechanic in laying out work.

*Third:* Upon completion of the general problem course, and the general introductory course in geometrical and mechanical drawing each apprentice takes up the study of his particular trade course. This includes:

- (1) A set of problems bearing particularly on the work of the trade.
- (2) A thorough exercise in the reading of working drawings. The assignments for this work pertain to blue prints of standard Southern Pacific drawings.
- (3) A thorough exercise in free-hand sketching from models taken from each trade. These models are numbered and graded so as to make the sketches increasingly difficult. For boiler-makers and tinsmiths, in addition to the exercises in reading working drawings and free-hand sketching, there is provided a thorough course in laying out patterns suited to the needs of each trade. These patterns are laid out on large sized wrapping paper and then cut out and turned to the desired shape.

### INDIVIDUAL PROGRESS CHARTS

In the larger shops, where the number of apprentices warrants, shop instructors are employed who give their entire time to this work. The schedules of shop training for the several trades are followed as closely as possible, and in order to insure to each apprentice a well rounded training, an individual progress chart is kept showing graphically the amount of time spent on each part of the work outlined in the schedule. Entries are made on these charts twice a week by the school instructor when the apprentices are attending school. Shop foremen and shop instructors are kept informed by the school instructor when apprentices have completed their prescribed time on the dif-

\* From an article in the January, 1916, Bulletin of The National Association of Corporation Schools.

ferent classes of work. A seniority chart is posted in the school room and advancement is strictly according to seniority.

All records and progress charts are kept open to the apprentices, and the instructors consult freely with them concerning their progress and make an effort, so far as practical, to let each one specialize along the particular line for which he seems most fitted or in which he may show a continued interest.

The system outlined above is having the effect of bringing the shop and the school in close touch. In making the entries on an apprentice's progress chart, the school instructor must of necessity ask him questions about his work. The answers given not only serve as a basis for the record kept, but very often lead to little conversations which help the instructor to learn where the weak points in the shop training are. He is then in a position to take the necessary steps toward investigating and remedying defects, and so the system improves.

#### GAINING CONFIDENCE OF STUDENTS

Experience has proved most forcefully that where the attitude of the instructor is one of genuine friendly interest, the boys will gradually place more and more confidence in him and will finally look upon him as their champion; this places the instructor in a position of peculiar helpfulness both to his company and to the apprentices. By remedying defects in the shop training of the boys, he demonstrates to them his interest in their welfare, and by standing openly and unswervingly for the exercise of conscience and honesty in the performance of work, he helps in building up of an efficient and reliable working force.

Owing to the short time which the new apprentice system has been in operation on the Southern Pacific the results attained so far as they can be expressed in figures would not particularly impress the casual reader. But to those who come in daily contact with the apprentices, the results of less than three years' work are clearly indicative of the fact that apprentice instruction is to be regarded as an investment and not as an expense.

#### WHAT THE WORK ACCOMPLISHES

Some of the observations which are commonly heard about the shop and which would tend to establish the truth of the above statement are:

- (1) A better class of boys apply for apprenticeships.
- (2) The boys show more interest in their work and are more attentive to their duties.
- (3) The boys display more thought and judgment and are not so dependent as they formerly were.
- (4) The so-called "arts and mysteries" of the trades are vanishing and boys now learn early in their apprenticeships to perform work which, in former times, was jealously guarded by the "old time" mechanic.
- (5) Boys are being encouraged to give their suggestions both in the interest of safety and efficiency. As they see their suggestions acted upon, and as they receive acknowledgment for them, they come to feel a personal interest in the affairs of their shop. No statement can be given either in figures or words which can show the direct or indirect benefit which comes to any company through its educational work. To the extent that such educational work is conducted by men who command the respect and confidence of the young employees, will the benefits of educational work exceed those of mere instruction. For this reason, the apprentice instructor both in the school and in the shop should be a man of large ideas as to the possibilities of his work.

The excellent article by George M. Basford on "The Training of Young Men with Reference to Promotion," which appeared in the Railway Age Gazette of July 23, 1915, has borne fruit in the Southern Pacific apprentice schools through the introduction of a system by which promising young men in the service are periodically "sized up" on a blank enumerating desirable characteristics as outlined in Mr. Basford's article. This system has already been used to good advantage in choosing young men for advancement.

#### WHAT THE FUTURE HOLDS

While the record of the modern apprenticeship system on the Southern Pacific has been one of rapid development and gratifying results, the future must be one, not only of greater perfection along present lines of activity, but of advancement along other lines which come legitimately within its sphere.

Probably the most pressing present need is for a more complete organization of the apprentice system. To completely standardize the present instruction work at all points on the system, as well as to inaugurate and direct work along more advanced lines, requires a central head. An officer in charge of the educational work would supply to the instructors a uniform backing and support independent of the co-operation, or lack of co-operation, of their local shop superiors.

A very much needed branch of the work of instructing apprentices is that which would open up to them the possibilities for greater efficiency in shop operations. This subject, taken up and followed in a progressive and systematic way, seems thus far to have received but little attention throughout the country. The experience of all who have undertaken the work of demonstrating the possibilities for increased output from shop tools and from shop methods generally has shown the need for a campaign of education calculated to remove blind prejudice and to instill an appreciation of scientific methods for carrying on shop work. This subject belongs to the apprentice school primarily, for our best work along this line can be done by creating in the minds of the rising generation of mechanics a correct view of the purpose and merits of the efficiency movement in industrial life.

#### SELECTING YOUNG MEN TO DEVELOP

Within our apprentice schools are many young men of unusual intelligence and ability. The near future will doubtless see the establishment of special apprenticeships for these young men, by means of which they may be given the opportunity for a more complete training within the mechanical department. From such material we shall be able to draw our future foremen. This subject must receive careful and continued attention if we are to build up an organization of the highest order.

Undoubtedly a most valuable work can be accomplished through the apprentice schools in the gradual building up of a better and more cordial relation between employer and employee. The apprentice instructor stands in a position of exceptional advantage in this regard. In a very real way he acts as the interpreter of his company's policy toward its employees. If humanity and squareness are the chief characteristics of his attitude toward them he can do much toward developing, as the years go by, that feeling of unity and co-operation which is always the basis of the most successful organization.

#### LOCOMOTIVE REPAIR INDICATOR

To any one, either workman or an officer, passing through the average locomotive erecting shop, it is more or less difficult to determine the numbers of the locomotives, or the class of repairs which they are receiving. Ordinarily even the workman engaged on any particular locomotive can only hazard a guess as to the date it is expected to be out of the shop. It is the practice in some shops to have printed lists of the engines in the shop and the class of repairs they are receiving, with the dates when they are expected out, these lists being distributed among the various departments. This is a good system so far as it goes, but there should be a record on the locomotive itself, placed where it can easily be seen. The method of painting signs showing the dates the engines came into the shop, and when expected out, is not very satisfactory as for various reasons it often becomes necessary to change these dates.

The indicator card shown in the illustration is so simple and the numbers so easily changed that it will at once commend itself to any one who has supervision over the repairing of locomotives or any class of machinery where it is desired to show class of work and date on which it is expected out of shop. The

card is made of tin, painted black, rectangular in shape, 10 in. by 18 in., with suitable holes or clips at the top for attaching the wire by which it is hung up. Near the top of the card are soldered small strips of tin forming slides or pockets. There are four of these pockets for the engine number. In the center is placed a slide or pocket, between the words CLASS REPAIRS, and three slides are placed at the lower right-hand corner, preceded by the words DATE EXPECTED OUT, which are painted on the card. These are for the month and day of the month.

The interchangeable numbers, of which there should be quite



Locomotive Repair Indicator as Used in the North Springfield (Mo.) Shops of the Frisco

a number, are painted on squares of tin, two inches square, with the top edge bent over at right angle to facilitate removal from the pocket. The card shown in the illustration indicates engine number 2692, undergoing Class 3 repairs, and expected out of the shop January 26. Should it become necessary to change this date to February 1, a 2 would be substituted for the 1, and the 2 and 6 would be removed and 1 placed in the last pocket. On roads where letters are used to designate class repairs, the letters indicating light, heavy, general, or wreck, may be used in the central pocket. A piece of  $\frac{1}{4}$  in. x 1 in. iron, bent at a right angle, with a small hook on one end and the other end bent down so as to slip into classification lamp bracket, makes a good place to hang the card. This places it about eight inches to one side of smoke arch, but still leaves it parallel with the frame; in this position it is not disturbed by the removal of the front ring or by the men removing or replacing tubes or steam pipes. The indicator card illustrated is used on the St. Louis & San Francisco.

## REAL EFFICIENCY IN SHOP OUTPUT

BY JOHN V. LACOMPTÉ

The greatest factor in effecting and maintaining shop efficiency is competent supervision, the highest standard of which cannot be gaged by the number of locomotives repaired per month, or by the record that can be made in the repairing of one locomotive at the expense of the others in the shop. Economy demands that locomotives spend the greatest part of their time in earning money, and the efficiency is governed by the condition of the locomotives as received from the classified repair shops, the handling of the locomotives by engineers and firemen, and the repairs made in the roundhouse.

The best practices of handling the various parts of locomotives and cars are often passed by, not because convincing evidence cannot be produced to prove that better methods can be inaugurated or a better system installed, but because the management is not prepared to meet demands for increased expenditures, seemingly losing sight of the great return from a comparatively small outlay (first cost).

The main repair shops are where the repairing of the locomotives and cars should be handled with the greatest degree of efficiency; it is there that the faulty designs are corrected; it is there that the best machinery is installed (or should be) to take care of every line of work. Where one operator's time is spent entirely in taking care of one line of work, as is often the case, the best results should surely be produced. When efficiency is dealt with fairly, there will not be a crying demand to secure a certain number of locomotives or cars for the month's output, but rather for a higher state of perfection in all lines of work, that the equipment may give effective service continuously and a much greater time elapse between the shoppings.

I do not mean to infer that the largest number of locomotives and cars should not be gotten out, consistent with good workmanship, but I do mean it is not efficiency to slight the work. Quality and quantity combined will produce the best results in the shops; so also technical and practical knowledge combined produces our best mechanics.

## GETTING RESULTS IN AN APPRENTICE\* SCHOOL

BY HAROLD V. STYERS  
Warwick, N. Y.

It was my good fortune to help start the apprentice school on the Lehigh Valley, where I was a student for one year when I completed my time and lost my rights to the school. After I had been with my present employer about two months and had made the acquaintance of a number of the apprentices, I told them the way boys were learning their trades on some of the larger railroads. This started them to thinking and aroused their desire for something better.

In company with another young machinist and the general foreman we called a meeting one noon after lunch. After telling the boys actual facts about my apprentice school training and the advantages offered by the larger roads to their apprentices, the boys decided to meet every noon after lunch for about 40 to 45 minutes. As our company is small, we did not ask for any equipment, but made use of the things we had at hand. We had a small room over the storehouse that could be utilized for a school room. We secured a sheet of 1/16 in. steel about 4 ft. by 8 ft. and painted it a flat black and set it on a roughly constructed easel. The car department gave us some old coach seats. The storehouse furnished some old out of date reports, which supplied us with paper. We nailed these on  $\frac{1}{2}$  in. by 12 in. by 14 in. white pine boards and gave one to each lad to hold on his knees to figure on. The boys supplied their own pencils.

With plenty of chalk and an eraser we were ready to go to work. I undertook to act as instructor and with the help of all, we certainly enjoyed our noons—in fact one o'clock came too soon.

I started in at the beginning of arithmetic and gave the boys the advantage of all the short cuts I could get hold of to keep them interested. While we were working in decimals, I took a pair of micrometers to show them how important it was to have a good command of decimals and fractions. As different things came up in the shop that we could figure on, we would get the dimensions and work them out. For instance, we figured the amount of water in gallons that could be put in the cistern of one of our tanks. We have also figured the difference in the heating surface in an engine equipped with a superheater and one of the same class without the superheater. I have also taught some of the young machinists and boilermakers between 5 and 6 p. m. twice a week.

If I had the equipment, I would teach the boys enough mechanical drawing so they could make a sketch of a piece of work they might want made, read a blue print quickly, or lay out a

\* Entered in the competition on "How Can I Help the Apprentice?" which closed September 1, 1915.

piece of work to be machined. It is always well to have some stiff problems for the last of the lesson to keep all hands busy; also mix up with the boys and assure yourself that they are all started right.

### DRIVING BOX REPAIRS

BY R. L. PRESTON

Machinist, St. Louis, Iron Mountain & Southern, Argenta, Ark.

The article on "Driving Box Repairs," by P. E. Smith, published in the October issue of the *Railway Age Gazette, Mechanical Edition*, on page 527, was of particular interest to the writer, who is engaged in driving box work. Considerable improvement in driving box practice has been effected at this point during the past year, largely through a more general use of second-hand brasses.

On January 1, 1915, the writer started a record of all new and second-hand brasses used, to see what could be saved on driving box supplies in one year. Previous to that time there were very few second-hand brasses used. As from four to eight boxes are received to the set, six boxes may be considered an average set. For the nine months ending September 30, 1915, 158 sets of driving boxes were handled. The driving box gang

new brass had been used instead of the second-hand brass, 56,835 lb. would have been required, which, at a cost of \$15.75 per 100 lb. would have cost \$8,952. The difference between this and the \$4,620, the value of the second-hand brass, is \$4,331, or the saving made by the use of the second-hand brass.

The method followed in handling a set of boxes from the time they are taken from the wheels to the time they are ready to go on again is as follows:

First: Mark all boxes and brasses and press out the brasses with a hydraulic press.

Second: Remove the cast iron hub plates by drilling off the heads of the plugs which hold the plates in place.

Third: Fit new brasses, or shim and close the old ones.

Fourth: Fit the old brasses or lay off the new brasses.

Fifth: Shape the edge of the brasses on a Newton vertical miller. (See Figs. 1 and 2.)

Sixth: Press the brasses in the boxes at 20 to 40 tons pressure.

Seventh: Plane the boxes.

Eighth: Fit and drill the cast iron hub plates and drill the boxes for the brass plugs.

Ninth: Face and bore the boxes to fit the journals. Note the driving box chuck in Fig. 3. This is a universal chuck, and was built in this shop.

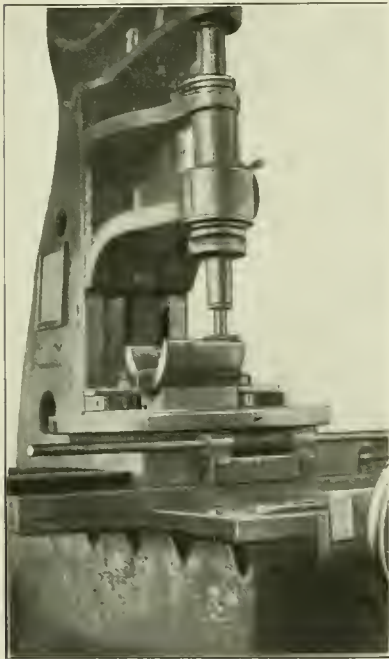

Fig. 1—Milling Driving Box Brasses

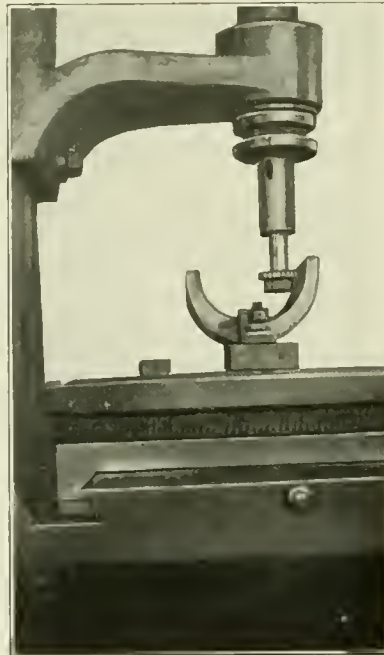

Fig. 2—Milling Driving Box Brasses

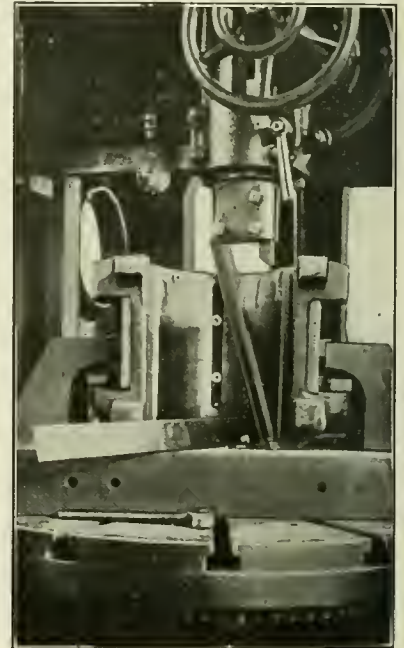

Fig. 3—Boring Driving Brasses with Universal Chuck

consists of three machinists, one apprentice, one helper and one handy-man. There are one machinist and a helper on the bench, who strip all boxes and do the floor work, such as laying off the brasses, pressing them in, and fitting the cellars. Whenever a cellar is loose in the box, it is tightened by riveting a liner of the necessary thickness (very seldom more than 1/16 in.) on one side of it. Cast iron hub plates are used on driving boxes instead of babbitt, as we find they give better satisfaction. They are held in place by counterboring the box and driving four taper-headed pins 25/32 in. in diameter into 3/4-in. countersunk holes. These pins never work loose. Our average time on one set of six driving boxes is eleven hours and five minutes. The gang is seldom worked to full capacity.

Our average on the brasses used for the nine months from January 1, 1915, was 54 per cent new and 46 per cent second-hand. The weight of the new brass used was 66,720 lb., which, at a cost of \$15.75 per 100 lb., is \$10,508.40. The weight of the second-hand brass used was approximately 33,000 lb., which, at a scrap value of \$14 per 100 lb., is worth \$4,620. If

Tenth: Place the cellars in the driving boxes and truck them to the wheels.

This gives the complete working order in which driving boxes are handled at this place. The following is the time it would take one man to complete a set of six driving boxes. The time mentioned in the first part of this article is our average time for nine months, using two boring mills on box work.

Press out the brasses and drill off the hub plates.....	30 min.
Cut six liners and place them in the boxes. Close six brasses, chip and set them in the boxes.....	37 min.
Mill six brasses.....	1 hr.
Press six brasses into the boxes.....	16 min.
Plane six driving boxes.....	3 hrs.
Fit six cast iron hub plates.....	3 hrs.
Drill six hub plates, pin the plates on the boxes and drill the plug holes in the brasses.....	2 hrs. 10 min.
Face and bore six boxes (cast iron hub faces).....	9 hrs.
Fit the old cellars in the boxes.....	1 hr.

The total time for one man to complete six driving boxes will be 20 hours and 32 minutes. When new brasses are used the time will be 22 hours 30 minutes for 9-in. by 12-in. journals.

# NEW DEVICES

## INCANDESCENT ELECTRIC HEADLIGHT

To meet the demands of the railways for incandescent headlight equipment the Schroeder Headlight Company, Evansville,

generators having capacities of 350 watts and 1,000 watts, respectively. The 32-volt, 350-watt system has had the most extensive use up to the present time, it being the first of the incandescent equipment of that company to be placed on the

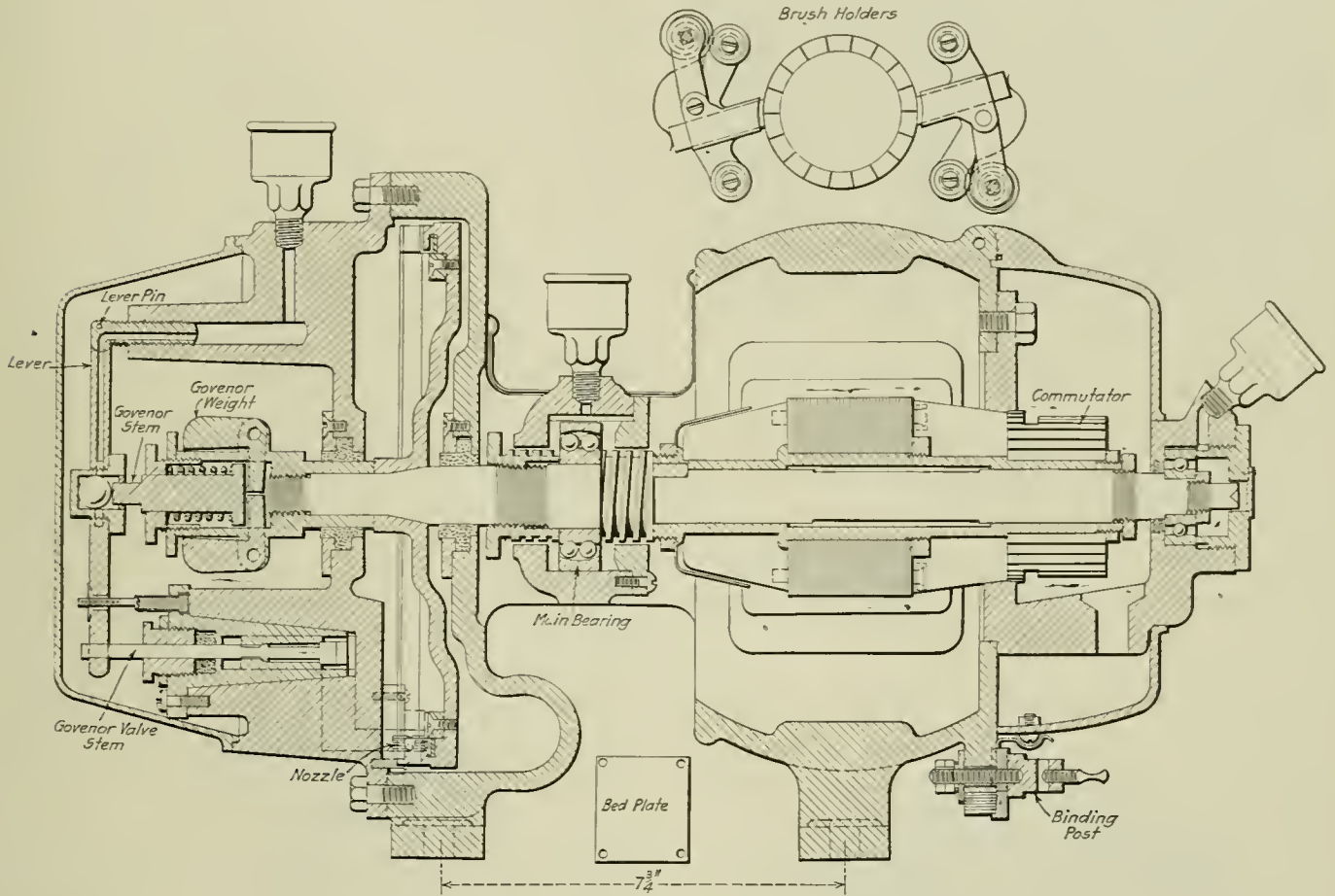

Sectional View of the 32-Volt, 350-Watt Headlight Generator Equipment

Ind., has for the past few years given much attention to the development of this equipment. At the present time it has on

market. It has already been made standard on some roads in view of the service it has performed. The following is a statement of the yearly maintenance cost of eight of these equipments reported by a road operating in the Middle West:

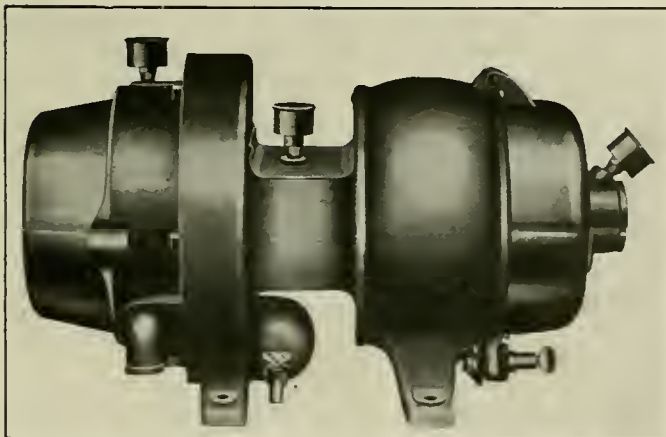

Schroeder 32-Volt, 350-Watt Headlight Turbo-Generator

the market three types of equipment, namely, the 6-volt turbo-generator having a capacity of 150 watts, and two 32-volt turbo-

Repairs to turbo-generator*	\$ .75
Labor and cost of lubrication	39.84
Incandescent headlight lamps	43.20
Incandescent cab lamps	8.51
Total	\$92.30

\* This item was for carbon brushes, showing a perfect record for the mechanical construction of the machine.

This is an average of \$11.54 per machine per year. This road uses 150-watt concentrated filament lamps on its road engines and 60-watt lamps of the same type at the front and back of the yard engines. The equipments are handled by the round-house machinist, who examines the brushes and generator about every 1,000 miles. Another road operating 212 headlights of this same type finds that with 100-watt, 125-candle power lamps the requirements of the Illinois state laws are more than met. Tests of the 32-volt equipment made by this road with equipments which have been in service six months showed that the voltage did not vary more than  $2\frac{3}{4}$  volts between boiler pressures of 100 lb. and 180 lb. This road also reports favorable mainte-

nance costs, stating that they do not amount to one-half that spent for the arc light equipments.

The headlight equipments made by the Schroeder Headlight Company are all of the same general design, the only difference being in the size of the equipments. They will operate at any pressure from 75 lb. up. The 32-volt outfit weighs 175 lb., and is 13 in. high, 24 in. long, and 12 in. wide. The body of the generator and the turbine is cast in one piece, insuring strength, rigidity and bearing alinement. Both the turbine wheel and the armature are fastened to the same shaft, which rotates on two

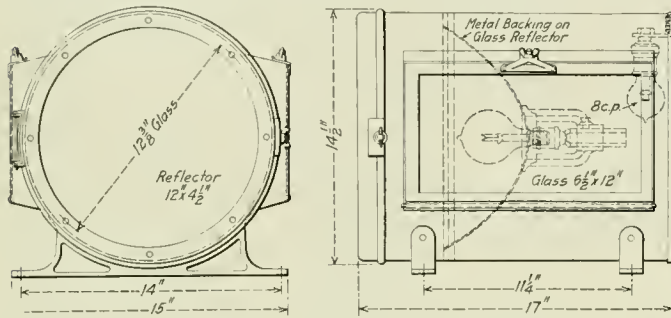

Arrangement of Reflector and Number Plate Lamp in the Sunbeam Headlight

sets of ball bearings, one located between the generator and the turbine wheel, and the other at the commutator end of the equipment. The generator is of the two-pole type and operates at a speed of 2,400 r.p.m. The commutator is made extra heavy, and will permit of several machinings before renewal is necessary. The armature can be removed quickly; the outside bearing housing is readily removed by taking out three cap screws and one retaining nut.

Steam from the boiler is admitted to the turbine through a governor valve that is automatically controlled by a centrifugal governor on the end of the turbine shaft, which, by regulating the valve opening, maintains constant turbine speed.

In designing this turbo-generator care was taken to keep all parts easily accessible for inspection or repairs, and to provide large bearings. A detachable outer shell at either end provides

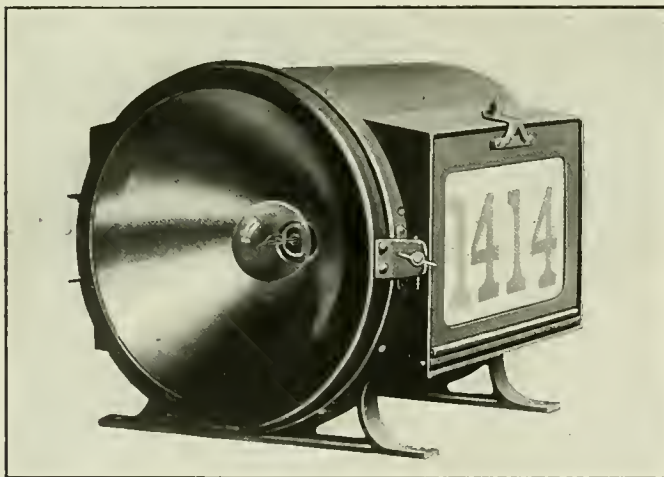

The Sunbeam Headlight

almost instant access to the governor on one end and the armature on the other. Further removal of a cast iron housing, which is held by set screws, gives access to the turbine wheel or armature. Lubrication is provided for by grease cups and large grease wells which surround the ball bearings, making daily attention unnecessary.

The six-volt turbo-generator system is the latest development. It has a capacity of 150 watts at 2,400 r.p.m. The weight is 120 lb., and the over-all dimensions, 14 in. by 19 in. by 15 in. high. The machine is built either with or without the throttling

governor. When used without the governor the speed is kept practically constant by means of a reducing valve supplemented by a patented friction device which prevents excessive speed. Grease is prevented from leaking out of the bearings by bushings having spiral oil grooves cut in them, which tend to return the lubricant to the bearings. This effects economy in lubrication and also prevents grease from getting on the generator windings.

This company also makes the headlight case and fixtures, which is known as the "Sunbeam" headlight. It is made for either a 6-volt or a 32-volt system, the only difference being in

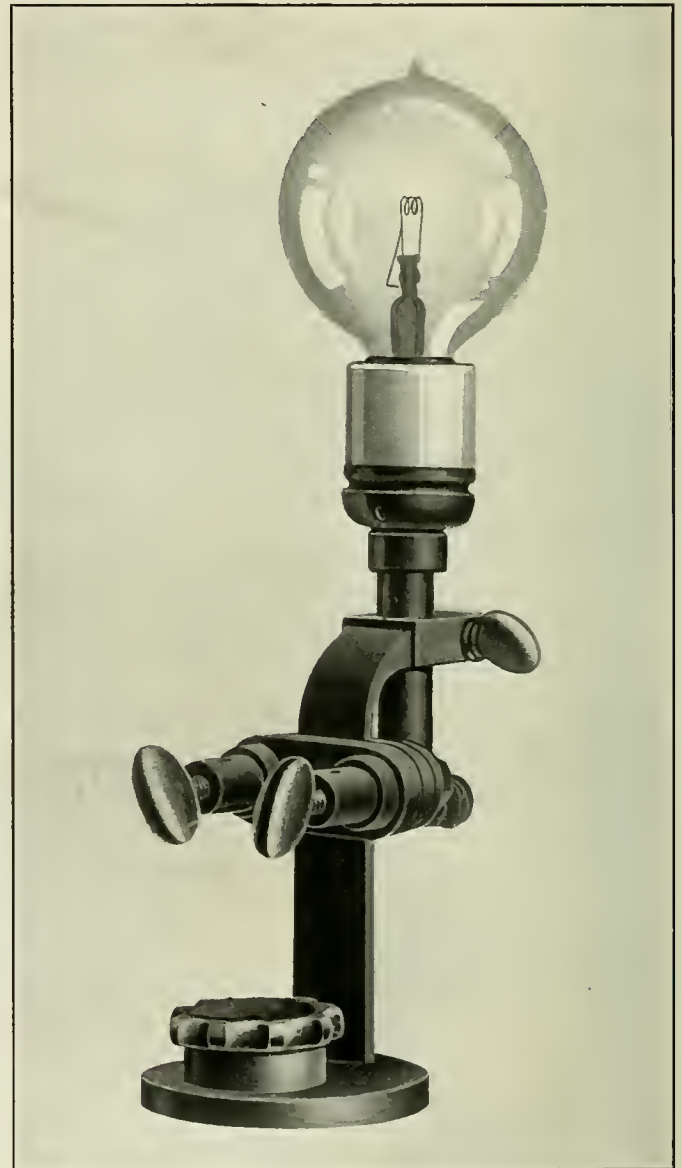

Adjustable Focusing Stand for Old Type Headlight Cases

the incandescent light bulb. It has a heavy 12-in. mirror glass reflector slightly colored to make the light more penetrating. This never needs replating and does not tarnish. The lamp socket is adjustable, permitting the use and accurate focusing of any size incandescent round bulb or concentrated filament nitrogen lamp up to 250 watts. The distance at which objects can be discerned varies from 800 ft. to 2,000 ft., depending on the type of lamp used.

Number plates are provided at each side of the headlight, which are illuminated by a small bulb at night.

The headlight case is substantially constructed of metal; the doors are swung on heavy hinges and secured, when closed, by thumb screws, making it dust proof. It is supported by heavy



iron brackets riveted to the body of the headlight and bolted to the support on the locomotive.

Headlights with other types of reflector can be furnished in any special size and design having any size or type of number plate. This company also makes adjustable stands for incandescent bulbs for use in old type headlight cases, having large or small reflectors. These stands are adjustable to permit of properly focusing the bulb.

**EFFECTIVE CAR DOOR FASTENERS**

Two box car door fasteners are illustrated herewith which have been designed to meet all M. C. B. requirements as to construction and which are burglar-proof. Both are adapted to the use of any type of car seal and may be fastened with a padlock with equal facility. These fasteners are made by the Universal Car Seal & Appliance Company, Albany, N. Y.

The metal door stop of the "Universal Gibraltar" fastener

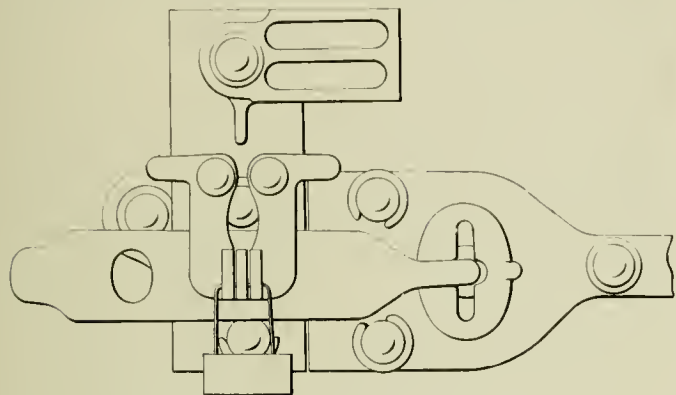

Universal Gibraltar Car Door Fastener

carries two gravity pawls which swing down against the hasp lug. Through the ends of these pawls are holes which are in line with the hole through the lug. When the hasp is in place these drop down in front of it, and when a seal has been applied through the registering holes in the pawls and lug, it is impossible to remove the hasp without breaking the seal. The operation is very simple; it is necessary only to spread the pawls by compressing the outward extending upper ends between the

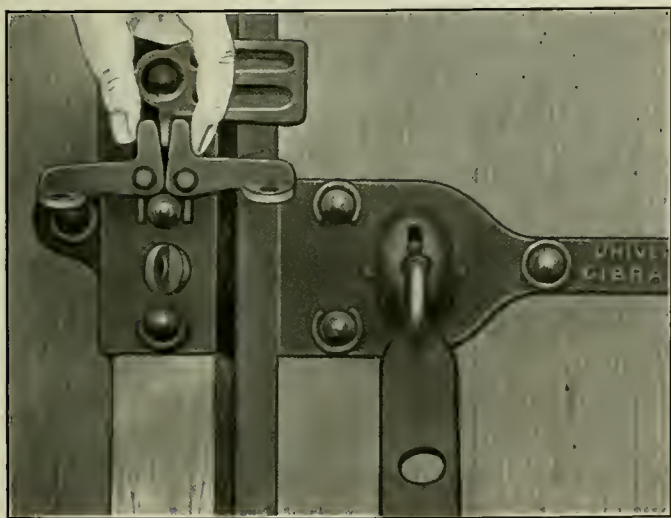

Method of Operating

thumb and forefinger of the left hand while the hasp is handled with the right hand.

The door stop is a channel casting of malleable iron which envelops the car door stop, and serves also as a door guide. Both this and the door strap are gained in on the adjoining faces, thus providing flush metal surfaces of contact. The

prying of doors which stick or bind is thus possible without injury to the woodwork.

All bolts are fastened inside the car, so that removal from the outside is impossible and none of the parts can be separated without removing the fastener from the car. It is made of malleable iron throughout and weighs 12 lb.

The "Universal Simplex" door fastener is a lighter and cheaper device than the one above described, having a weight of only 6½ lb. It possesses the same features of construction to secure

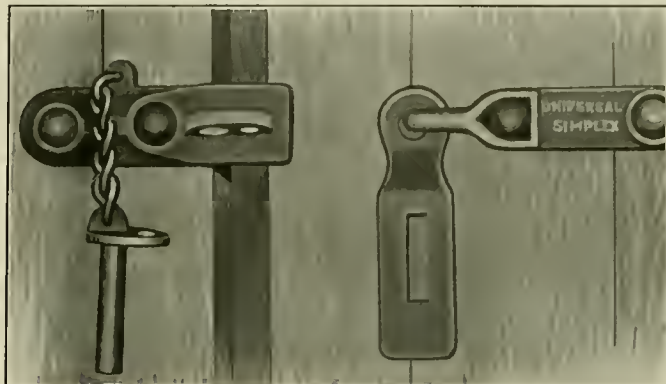

The Universal Simplex Fastener

safety and is easy to operate. The lug is extended to provide for two holes through it. One of these is for the pin and the other for the seal. The pin has a flat head, in which is a hole registering with the second hole in the lug when the pin is in place in front of the hasp. When sealed through these holes the hasp cannot be removed from the post without breaking the seal. The locking pin is secured to the stop casting with 6 in. of heavy welded chain.

**A LOCKING PIPE UNION**

A pipe union of unusual construction has recently been developed by the Standard Union Company, 612 Winthrop building, Boston, Mass. The features of the device are clearly set forth

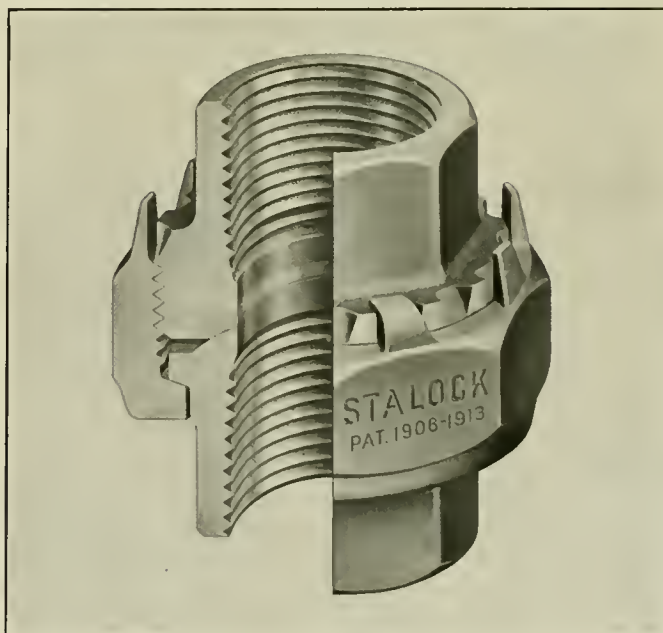

The Stalock Union

in the illustration, which shows a section of the seat exposed. The union has a ground ball joint, the concave seat being formed in a brass seat ring which is interlocked in position. It thus involves the best modern practice of a brass to iron con-

tact to prevent corrosion. On the upper face of the nut, which is of malleable iron, are cast a number of lugs. The upper body of the union is cast with a number of notches or recesses in the shoulder just above the threads. The shoulder on one side of these depressions is square and the other is sloping. To lock the nut one of the lugs is bent into one of the recesses by a blow from a wrench or hammer, at least two diametrically opposite lugs always being in position to be locked. The square shoulder of the recess prevents the thread from slacking back, but should it be necessary to further tighten the union it may be done without difficulty, as the sloping shoulder of the recess will force the lug out of engagement when the wrench is applied.

This union is known as the "Stalock," and has been developed especially to meet the severe requirements of railroad work.

## GRAPHITE CYLINDER LUBRICATOR

A simple device has recently been developed for introducing flake graphite into locomotive cylinders which is entirely self-contained, no motion derived from moving parts of the engine being required. A cup, arranged for attachment to any convenient part of the locomotive, contains the graphite and is connected by a short tube to one of the indicator plug holes in the cylinder. The device is usually attached to some point on

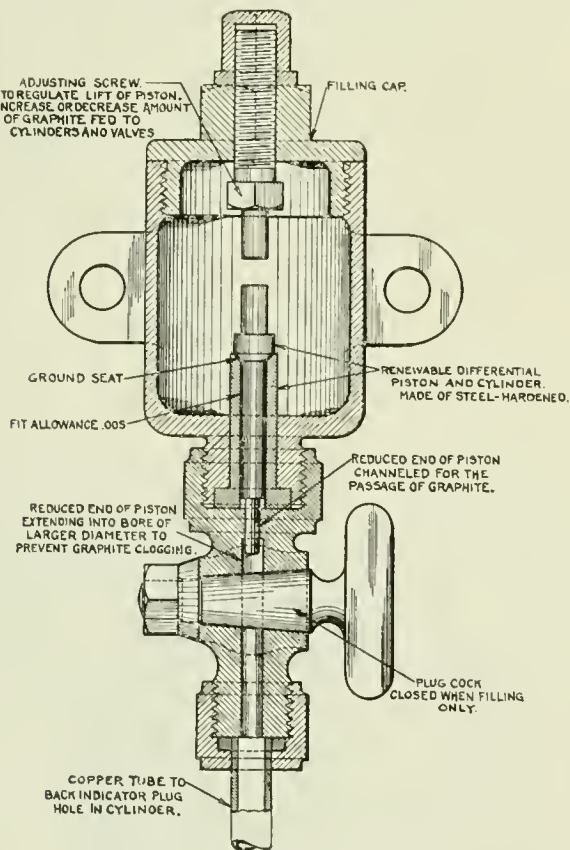

Automatic Graphite Lubricator

the cylinder casting by means of the bolting lugs shown in the drawing.

The graphite cup contains a small cylinder within which works a differential piston operated by the pressure variations in the locomotive cylinder. The graphite is thus worked into the small copper pipe connection and thence into the cylinder; the amount is determined by the stroke of the differential piston. The filling cap contains an adjusting screw by which the stroke of the piston is regulated. A plug cock is placed below the graphite cup to close the cylinder connection when filling the cup.

After the cup has been in operation on a locomotive for a few hours, the valve and piston rods are said to show indications of the graphite lubrication, a deposit being left on them which is visible from the outside. The graphite is carried by exhaust

steam into the valve chambers, thus effectively lubricating both the cylinders and the valve chambers. The device is applied without in any way disturbing or altering the existing method of oil lubrication. It merely supplements the oil lubrication. Large quantities of graphite are neither required nor desirable, the best results being obtained by the regular application of small quantities. Tests indicate that one-half ounce fed into each cylinder of an ordinary locomotive for each 100 miles run is sufficient. With this device it is claimed that the amount of graphite used may be very closely regulated and that no objectionable accumulation of graphite on the pistons, cylinder heads or in the steam ports follows its use.

The lubricator has been in service on a number of locomotives for some time. Some of these engines were equipped with superheaters and were operating at temperatures as high as 720 deg. to 740 deg. Fahrenheit in some instances. Under these severe conditions no trouble has been experienced with the lubrication. In a comparative test conducted over a period of about one year, a locomotive equipped with the graphite cup ran 56,000 miles with a total average cylinder wear of .014 inch as against a mileage of 48,000 with a total average cylinder wear of .056 inch for a locomotive not so equipped.

The average packing ring wear in the locomotive lubricated with graphite was only 1/32 in., while the other locomotive received two new sets of rings during the test. The graphite used cost less than one cent per 100 miles, and the estimated saving, based on cylinder and ring wear alone, was approximately \$40. Because of the reduced friction, there was also claimed to be an appreciable saving in fuel consumption.

This lubricator has been patented by E. H. Sweeley, Richmond Hill, N. Y.

## PNEUMATIC SPRING BANDING PRESS

A pneumatic press for applying bands to leaf springs has recently been placed on the market by Joseph T. Reyerson & Son, Chicago. The machine is especially designed for use in railroad and commercial spring manufacturing or repair shops

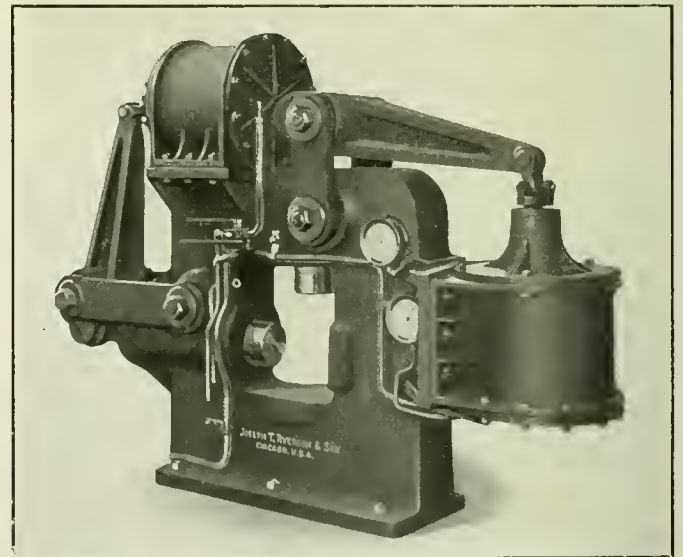

Spring Banding Press of 100 Tons Capacity

which are not equipped with hydraulic power. It is operated by compressed air, being designed for 100-lb. pressure. The cylinders are of such a diameter that with this pressure a force of 60 tons is exerted on the rams. The cylinders and levers are attached to a heavy one-piece frame cast in the form of a hollow square, the rams operating in the opening. Each machine is provided with two three-way hand-operated valves and the necessary pressure gages, conveniently located for the operator.

The cylinders are 16 in. in diameter and the machine weighs complete 6,500 lb.

# Railway Mechanical Engineer

(Formerly the RAILWAY AGE GAZETTE, MECHANICAL EDITION with which the AMERICAN ENGINEER was incorporated)

PUBLISHED ON THE FIRST THURSDAY OF EVERY MONTH BY THE SIMMONS-BOARDMAN PUBLISHING COMPANY

EDWARD A. SIMMONS, *President* L. B. SHERMAN, *Vice-President*  
HENRY LEE, *Vice-President and Treasurer* M. H. WIUM, *Secretary*  
WOOLWORTH BUILDING, NEW YORK, N. Y.

Chicago: Transportation Bldg. Cleveland: Citizens' Bldg.  
London: Queen Anne's Chambers, Westminster.

ROY V. WRIGHT, *Editor*  
R. E. THAYER, *Associate Editor* A. C. LOUDON, *Associate Editor*  
C. B. PECK, *Associate Editor*

Entered at the Post Office at New York, N. Y., as mail matter of the second class.

Subscriptions, including the eight daily editions of the *Railway Age Gazette* published in June in connection with the annual conventions of the Master Car Builders' and American Railway Master Mechanics' Associations, payable in advance and postage free: United States, Canada and Mexico, \$2.00 a year; Foreign Countries (excepting daily editions), \$3.00 a year; Single Copy, 20 cents.

WE GUARANTEE that of this issue 7,800 copies were printed; that of these 7,800 copies 6,888 were mailed to regular paid subscribers, 101 were provided for counter and news companies' sales, 336 were mailed to advertisers, exchanges and correspondents, and 475 were provided for new subscriptions, samples, copies lost in the mail and office use; that the total copies printed this year to date were 15,600, an average of 7,800 copies a month.

The RAILWAY MECHANICAL ENGINEER, and all other Simmons-Boardman publications are members of the Audit Bureau of Circulations.

VOL. 90 FEBRUARY, 1916 NUMBER 2

## CONTENTS

### EDITORIALS:

Toning Up an Organization.....	57
The Apprentice Competition.....	57
Slack and Draft Gear Maintenance.....	57
Fuel Economics at Stationary Plants.....	57
Passenger Car Terminal Competition.....	57
Cost Versus Service.....	57
Feed Water Heater Question.....	58
Increased Locomotive Capacity.....	58
The Crying Need of the Car Department.....	59
New Books .....	59

### COMMUNICATIONS:

Kingan-Ripken Valve Gear Device.....	60
An Office Kink.....	60
Flat Wheels .....	60
A Plea for the Draftsman.....	60
Value of Attractive Shop Grounds.....	61

### GENERAL:

Southern Railway Dynamometer Car.....	62
Design of Hollow Crank Pins.....	66
Road Tests of Exhaust Nozzles.....	67
Locomotive Water and Coal Consumption.....	69
Fuel Economy .....	71
The Principles of Smoke Formation.....	72
The Danger of Overdoing Things.....	73
The Question of Promotion.....	74

### CAR DEPARTMENT:

Steel Roof for Box Cars.....	75
Steel Passenger and Freight Cars.....	76
Canadian Northern Passenger Cars.....	77
The Foundation Brake Gear.....	82
Reclaiming Car Truck Pedestals.....	82
Report of the I. C. C. Division of Safety.....	83
The Car Inspector and His Job.....	85

### SHOP PRACTICE:

Grinding Dry Pipes.....	87
Welding High Speed Steel to Soft Steel Shanks.....	87
Piston Valve Packing Rings.....	88
Chuck for the Manufacture of Flue Cutter Blades.....	88
The Selection of Machine Tools.....	89
Oil Cans of Rational Design.....	91
Power Operation of Ratchet Jacks.....	91
Help the Apprentice to Help Himself.....	92
Laying Out Eccentric Keyways.....	92
Better Locomotive Boiler Inspection.....	93
Notes on the Button-Head Radial Stay.....	96
Apprentices on the Southern Pacific.....	97
Locomotive Repair Indicator.....	98
Real Efficiency in Shop Output.....	99
Getting Results in an Apprentice School.....	99
Driving Box Repairs.....	100

### NEW DEVICES:

Incandescent Electric Headlight.....	101
Effective Car Door Fasteners.....	103
A Locking Pipe Union.....	103
Graphite Cylinder Lubricator.....	104
Pneumatic Spring Banding Press.....	104

### NEWS DEPARTMENT:

Notes .....	105
Meetings and Conventions.....	106
Personals .....	106
Supply Trade Notes.....	108
Catalogues .....	110

## NEWS DEPARTMENT

### CARS AND LOCOMOTIVES ORDERED IN JANUARY

During the month of January orders for locomotives, freight cars and passenger cars were reported as follows:

	Locomotives	Freight Cars	Passenger Cars
Domestic .....	231	14,613	310
Foreign .....	2	11,000	...
Total .....	233	25,613	310

Among the more important orders for locomotives were the following: Delaware, Lackawanna & Western, 10 Mikado and 7 Pacific type locomotives, American Locomotive Company; Erie, 10 Santa Fe type locomotives, Baldwin Locomotive Works, and 10 of the same type, American Locomotive Company; New York Central Lines, 35 locomotives, American Locomotive Company, including 5 Mallet type engines for the New York Central proper, and 20 Mikados and 10 switching locomotives for the Indiana Harbor Belt. The Pennsylvania authorized its Juniata shops to proceed with the construction of 45 Mikado and 60 switching locomotives for the Lines East of Pittsburgh.

Almost one-half of the freight cars ordered for domestic use were for the Pennsylvania Railroad, which placed orders with the Cambria Steel Company for 3,000 hopper gondola cars, with the Ralston Steel Car Company for 2,000 of the same type, and with its own Altoona shops for 1,000 all-steel box cars. All of the 11,000 cars ordered for export were for France, contracts having been awarded to the Standard Steel Car Company for 5,000 cars, to the National Steel Car Company, Ltd., New Glasgow, N. S., for 4,000 cars, and to the Canadian Car & Foundry Company for 2,000 cars. Among other important domestic orders were the following: Denver & Rio Grande, 1,000 box cars, Pullman Company; Union Tank Line, 1,000 tank cars, Standard Steel Car Company; Missouri, Kansas & Texas, 1,500 gondola cars, American Car & Foundry Company; Lehigh Valley, 1,500 automobile cars, divided evenly among the Standard Steel Car Company, the Pullman Company, and the American Car & Foundry Company; the Bessemer & Lake Erie, 2,000 ore cars, Standard Steel Car Company, and the Baltimore & Ohio, 2,000 cars, Cambria Steel Company, and 1,000 cars, American Car & Foundry Company.

The most important passenger car order reported was that for 200 subway cars placed with the American Car & Foundry

Company by the New York Municipal Railways Corporation. The Pennsylvania ordered 50 coaches, 20 combination passenger and baggage cars and 5 baggage cars from its Altoona shops.

**MEETINGS AND CONVENTIONS**

*Railway Fuel Association.*—At a meeting of the executive committee of the International Railway Fuel Association, J. G. Crawford, vice-president of that association, and fuel engineer of the Chicago, Burlington & Quincy, was appointed secretary-treasurer, succeeding C. G. Hall, resigned. R. R. Hibben, assistant fuel agent of the Missouri, Kansas & Texas, was appointed vice-president, succeeding J. G. Crawford, and B. P. Phillippe, coal agent of the Pennsylvania Railroad, was appointed a member of the executive committee, succeeding R. R. Hibben. William Schlafge, mechanical superintendent of the Erie, was also appointed a member of the executive committee, succeeding W. C. Hayes, deceased.

*June Convention Exhibits.*—President Osby and Secretary Conway of the Railway Supply Manufacturers' Association are enthusiastic over the prospects for a record breaking exhibit during the Master Mechanics' and Master Car Builders' Convention at Atlantic City this year. On Saturday, January 8, a circular was sent out to prospective exhibitors outlining the conditions for making exhibits and stating that allotments of space would be made on February 18, 1916. On January 18, ten days after their circular had been mailed, applications had already been received—and space paid for—for 22,931 sq. ft., or more than 25 per cent. of the total space available. These applications came from 59 firms, six of which did not exhibit last year. A number of former exhibitors have applied for larger space this year. Indications at this time are that applications will be made for more space than it will be possible to provide.

*The following list gives names of secretaries, dates of next or regular meetings and places of meeting of mechanical associations.*

- AIR BRAKE ASSOCIATION.—F. M. Nellis, 53 State St., Boston, Mass.
- AMERICAN RAILROAD MASTER TINNERS', COPPERSMITHS' AND PIPEFITTERS' ASSOCIATION.—W. E. Jones, C. & N. W., 3814 Fulton St., Chicago.
- AMERICAN RAILWAY MASTER MECHANICS' ASSOCIATION.—J. W. Taylor, Karpen Building, Chicago.
- AMERICAN RAILWAY TOOL FOREMEN'S ASSOCIATION.—Owen D. Kinsey, Illinois Central, Chicago.
- AMERICAN SOCIETY FOR TESTING MATERIALS.—Prof. E. Marburg, University of Pennsylvania, Philadelphia, Pa.
- AMERICAN SOCIETY OF MECHANICAL ENGINEERS.—Calvin W. Rice, 29 W. Thirty-ninth St., New York.
- ASSOCIATION OF RAILWAY ELECTRICAL ENGINEERS. Joseph A. Andreucetti, C. & N. W., Room 411, C. & N. W. Station, Chicago.
- CAR FOREMEN'S ASSOCIATION OF CHICAGO.—Aaron Kline, 841 North Fiftieth Court, Chicago. Second Monday in month, except July and August, Lytton Building, Chicago.
- CHIEF INTERCHANGE CAR INSPECTORS' AND CAR FOREMEN'S ASSOCIATION.—W. R. McMinn, New York Central, Albany, N. Y.
- INTERNATIONAL RAILWAY FUEL ASSOCIATION.—C. G. Hall, 922 McCormick Building, Chicago.
- INTERNATIONAL RAILWAY GENERAL FOREMEN'S ASSOCIATION.—William Hall, 1126 W. Broadway, Winona, Minn. Convention, August 29-31, 1916, Hotel Sherman, Chicago.
- INTERNATIONAL RAILROAD MASTER BLACKSMITHS' ASSOCIATION.—A. L. Woodworth, Lima, Ohio.
- MASTER BOILER MAKERS' ASSOCIATION.—Harry D. Vought, 95 Liberty St., New York.
- MASTER CAR BUILDERS' ASSOCIATION.—J. W. Taylor, Karpen Building, Chicago.
- MASTER CAR AND LOCOMOTIVE PAINTERS' ASSOCIATION OF U. S. AND CANADA.—A. P. Dane, B. & M., Reading, Mass.
- NIAGARA FRONTIER CAR MEN'S ASSOCIATION.—E. Frankenberger, 623 Brisbane Building, Buffalo, N. Y. Meetings monthly.
- RAILWAY STOREKEEPERS' ASSOCIATION.—J. P. Murphy, Box C, Collinwood, Ohio.
- TRAVELING ENGINEERS' ASSOCIATION.—W. O. Thompson, N. Y. C. R. R., East Buffalo, N. Y.

**PERSONALS**

**GENERAL**

C. P. BURGMAN, master mechanic of the Chicago, Indianapolis & Louisville at Bloomington, Ind., has been appointed superintendent of motive power, with office at Lafayette, Ind., succeeding H. C. May, resigned.

F. F. GAINES, superintendent of motive power of the Central of Georgia at Savannah, Ga., has been granted leave of absence on account of ill health, and W. H. Fetner, master mechanic at Macon, Ga., has been temporarily appointed general master mechanic, in charge of the mechanical department, with headquarters at Savannah.

J. A. MACRAE has been appointed mechanical engineer of the Minneapolis & St. Louis, with headquarters at Minneapolis, Minn.

H. C. MAY, whose appointment to the position of superintendent of motive power of the Lehigh Valley was announced in these columns last month, began his railroad career with the Chesapeake & Ohio at Covington, Ky., where he served as machinist apprentice from 1892 to 1896. He was then machinist for three years at the same place. In 1899 he became a student in the Mechanical Engineering School of Purdue University at Lafayette, Ind., from which he graduated in 1902. He was then appointed master mechanic on the Cleveland, Cincinnati, Chicago & St. Louis at Louisville, Ky., remaining in that position until 1907. From 1907 to 1910 he served on the Louisville & Nashville as master mechanic at New Decatur, Ala., and at South Louisville, Ky., and since 1910 has been superintendent of motive power of the Chicago, Indianapolis & Louisville until his recent appointment with the Lehigh Valley. Mr. May's new headquarters are at South Bethlehem, Pa.

**MASTER MECHANICS AND ROAD FOREMEN OF ENGINES**

G. J. DUFFEY, master mechanic of the Lake Erie & Western, at Lima, Ohio, has been appointed superintendent of motive power, with headquarters at Lima, and the office of master mechanic has been abolished.

W. E. DUNKERLEY has been appointed master mechanic of the Yellowstone division of the Northern Pacific, with headquarters at Glendive, Mont., succeeding E. P. Jolmson, transferred.

J. B. HALLIDAY has been appointed acting master mechanic of the Central and Western divisions of the Minneapolis & St. Louis, at Minneapolis, Minn., succeeding William Gemlo.

T. HAMBLY has been appointed acting road foreman of locomotives, district 1, Lake Superior division, Canadian Pacific, with headquarters at Sudbury, Ont.

J. H. HANNA, assistant to the road foreman of engines of the Pennsylvania Lines west of Pittsburgh, Western division, has been appointed road foreman of engines, succeeding C. R. Colmey, deceased.

THOMAS F. HOWLEY, inspector of locomotive service of the Erie, at Port Jervis, N. Y., has been promoted to superintendent

**RAILROAD CLUB MEETINGS**

Club	Next Meeting	Title of Paper	Author	Secretary	Address
Canadian.....	Feb. 8.....	Car Construction.....	K. F. Nystrom.....	James Powell.....	St. Lambert, Que.
Central.....	Mar. 9.....	Interchange Rules. Discussion.....	Committee.....	Harry D. Vought.....	95 Liberty St., New York
New England.....	Feb. 8.....	Our Express Business.....	E. O. Robie.....	Wm. Cade, Jr.....	683 Atlantic Ave., Boston, Mass.
New York.....	Feb. 18.....	Pulverized Fuel for Locomotives.....	J. E. Mulhfeld.....	Harry D. Vought.....	95 Liberty St., New York
Pittsburgh.....	Feb. 25.....	Malleable Iron—Its Use and Abuse.....	Prof. Enrique Touceda.....	J. B. Anderson.....	207 Penn Station, Pittsburgh, Pa.
Richmond.....	Feb. 14.....	Electrication.....	C. H. Quinn.....	F. O. Robinson.....	C. & O. Ry., Richmond, Va.
St. Louis.....	Feb. 11.....	The Universal Valve.....	W. V. Turner.....	B. W. Frauenthal.....	Union Station, St. Louis, Mo.
South'n & S'wn.....				A. J. Merrill.....	Box 1205, Atlanta, Ga.
Western.....	Feb. 15.....	Smoke Abatement and Electrification in Chicago.....	Prof. W. F. M. Goss.....	Jos. W. Taylor.....	1112 Karpen Bldg., Chicago, Ill.
Western Canada.....				Louis Kon.....	Box 1707, Winnipeg, Man.

of locomotive operation, at New York, succeeding W. C. Hayes, deceased.

JOHN P. KENDRICK, master mechanic of the Buffalo, Rochester & Pittsburgh at Punxsutawney, Pa., has been promoted to master mechanic at Du Bois, Pa.

T. L. REED, assistant master mechanic of the Seaboard Air Line at Hamlet, N. C., has been appointed master mechanic of the North Carolina division, with headquarters at Hamlet, N. C. The position of assistant master mechanic is abolished.

J. D. SEARLE has been appointed master mechanic of the Buffalo, Rochester & Pittsburgh at Punxsutawney, Pa.

G. F. SHULL, acting master mechanic of the Carolina, Clinchfield & Ohio at Erwin, Tenn., has been appointed master mechanic, with office at Erwin.

W. H. STRANG, road foreman of engines of the Chicago, Indianapolis & Louisville at Lafayette, Ind., has been appointed general road foreman of engines.

JOHN WINTERSTEEN has been appointed general master mechanic of the Lehigh Valley, with headquarters at South Bethlehem, Pa. He will perform such duties as may be assigned to

him by the superintendent of motive power. Mr. Wintersteen was born in 1875, and began his mechanical experience as a boilermaker at the Lansford shops of the Lehigh Coal & Navigation Company. In 1898 he entered the service of the United States government at League Island, Philadelphia, Pa., and later served at Key West, Fla. He subsequently was in the service of the Baldwin Locomotive Works, then was boiler inspector on the Norfolk & Western at Roanoke, Va., and later served as general foreman in the Richmond



J. Wintersteen

shops of the Philadelphia & Reading Railway.

#### CAR DEPARTMENT

J. HERRING has been appointed car foreman of the Canadian Northern at North Battleford, Sask., succeeding A. H. Sweetman, transferred.

JOHN NEARY, general foreman of the car department of the Chicago, Indianapolis & Louisville at Lafayette, Ind., has been appointed master car builder.

T. REDMOND has been appointed car foreman of the Canadian Northern at Ottawa, Ont.

#### SHOP AND ENGINE HOUSE

J. BLACK, assistant locomotive foreman of the Canadian Northern at Kamsack, Sask., has been appointed locomotive foreman, succeeding S. Vincent, transferred.

C. T. DOCTOR has been appointed locomotive foreman of the Canadian Northern at Foleyette, Ont.

H. B. KRAFT, formerly foreman of the steel car shop of the Pennsylvania at Altoona, Pa., has been appointed foreman of the truck shop, succeeding J. W. Spangler.

A. MAYS has been appointed locomotive foreman of the Canadian Northern at Edmonton, Alta., succeeding W. M. Armstrong, transferred.

A. TAYLOR has been appointed night locomotive foreman of the Canadian Northern at Winnipeg, Man., succeeding J. Black, transferred.

S. L. TRACEY has been appointed locomotive foreman of the Canadian Northern at Toronto, Ont.

J. WEBB has been appointed locomotive foreman of the Canadian Northern at Bancroft, Ont.

J. H. WILSON has been appointed locomotive foreman of the Canadian Northern at Hornepayne, Ont.

T. YOUNG has been appointed locomotive foreman of the Canadian Northern at Lucerne, B. C.

#### PURCHASING AND STOREKEEPING

GEORGE W. CAYE, who has been appointed general purchasing agent of the Grand Trunk, with office at Montreal, Que., was born on December 1, 1865, at Malone, N. Y. In August, 1883,



G. W. Caye

he entered the service of the Central Vermont as junior clerk in the passenger department at St. Albans, Vt., and then was successively stenographer and chief ticket clerk until 1897, when he became chief clerk to the general superintendent. In 1900 he was appointed traveling car agent of the Canada Atlantic Railway, with headquarters at Ottawa, Ont., and in 1892 became secretary to the general manager of the same road. During 1905 and 1906 he served as chief clerk to the vice-president and general manager of the Grand Trunk

Pacific at Montreal, Que. In 1907 he became assistant to vice-president and general manager and purchasing agent of the same road, with headquarters at Winnipeg, Man., which position he held at the time of his recent appointment as general purchasing agent of the Grand Trunk.

J. D. FERGUSON has been appointed general purchasing agent of the Zwolle & Eastern, with office at St. Louis, Mo.

G. E. MORZ has been appointed purchasing agent of the Ft. Dodge, Des Moines & Southern, with headquarters at Boone, Ia., succeeding H. S. Moore, resigned.

#### OBITUARY

R. H. CREW, locomotive foreman of the Grand Trunk, at Nimico, Ontario, died in Toronto, Ontario, on December 7, as the result of a stroke of apoplexy. Mr. Crew was 48 years of age and had been in the employ of the Grand Trunk at Nimico for 28 years.

#### NEW SHOPS

THE NORFOLK SOUTHERN.—This company opened bids on January 15 for rebuilding the shops at New Bern, N. C., which were destroyed by fire on November 16. The total cost will aggregate about \$14,000. A contract for the work is reported let to J. Johnson, Norfolk, Va.

## SUPPLY TRADE NOTES

Frederick H. Eaton, president of the American Car & Foundry Company, died in New York on January 28.

The New York office of the Locomotive Stoker Company has been removed from Room 1032, 30 Church street, to Room 1381, 50 Church street.

A. E. Schafer, for the past two years vice-president and general sales manager of the Flint Varnish Works, Flint, Mich., has severed his connection with that company.

The Kilby Locomotive & Machine Works, Anniston, Ala., announces that henceforth the name of the company will be the Kilby Car & Foundry Company. There will be no change in the management of the company.

Benjamin M. Jones, president of B. M. Jones & Co., Inc., Boston, Mass., died at his home in Boston, November 26, age 78 years. Mr. Jones early entered the metal importing business, and dealt largely in railroad specialties.

The Harrison Safety Boiler Works, Philadelphia, Pa., announces that the company received a gold medal for the combined open feed water heater and hot water meter, known as the Cochrane Metering Heater, which is exhibited at the Panama-Pacific Exposition.

R. L. Mason, for fourteen years manager of the railroad department of Hubbard & Co., Pittsburgh, Pa., has severed his connections with that company, effective January 1, to go into the railroad supply business on his own account, with offices at 1501 Oliver building, Pittsburgh.

H. N. Turner, formerly eastern representative of the Kay & Ess Company, Dayton, Ohio, has been appointed sales manager of the company with headquarters at Dayton, and J. W. Wilson has been appointed eastern railway representative of the company, succeeding Mr. Turner.

Flint & Chester, Inc., New York, have opened an office in the People's Gas building, Chicago, from which they will handle in the west the National Graphite Lubricators for which the company is general sales agents in the United States and Canada. D. J. Lewis has been appointed manager of the Chicago office, effective February 1.

Charles A. Liddle, who has been elected vice-president of the Haskell & Barker Car Company, Inc., was educated in the Philadelphia public schools and commenced his business career as an employee of the Allison Manufacturing Company, of Philadelphia, Pa., builders of freight cars and manufacturers of boiler tubes. Except for a short interval, he has been identified with the car manufacturing business ever since that time, having been successively in the service of the Jackson & Sharpe Company and the Harlan & Hollingsworth Company, at Wilmington, Del., and the Pressed Steel Car Company, at Allegheny, Pa. Since 1901 he has been connected with the American Car & Foundry Company, first as an engineer and later as assistant to the vice-president and general manager, with office at Chicago, which position he has just resigned.



C. A. Liddle

James M. Buick, second vice-president of the American Car & Foundry Company, will be elected first vice-president of the company, succeeding Edward F. Carry, who recently resigned to accept the position of president of the Haskell & Barker Car Company. Herbert W. Wolff, assistant to Mr. Buick, has been made vice-president in charge of the Chicago sales department.

Paul Sutcliffe has been appointed advertising manager of the Edison Storage Battery Company, Orange, N. J. Mr. Sutcliffe joined the Edison interests in 1912, but resigned at the end of a year to become secretary of the W. S. Hill Advertising Company, Pittsburgh, Pa. He has been in the advertising department of the Edison Storage Battery Company for the past year.

David A. Crawford, who has been elected treasurer of the Haskell & Barber Car Company, Inc., New York and Michigan City, Ind., was born at St. Louis, Mo., on April 1, 1880. He attended the public and high schools at Tuscaloosa, Ala., and graduated from the University of Wisconsin with the degree of bachelor of arts in 1905. He remained at the university as an instructor until 1907, when he came to Chicago to become private secretary to E. F. Carry, vice-president of the American Car & Foundry Company. In 1912 he was elected assistant secretary of the American Car & Foundry Company, and continued in that position until January 13th, 1916, when he was elected treasurer of the Haskell & Barker Car Company, Inc.



D. A. Crawford

John E. Dixon, who has recently assumed his duties as vice-president in charge of sales of the Lima Locomotive Corporation, was from February, 1907, until his election to his new position, assistant manager of sales of the American Locomotive Company. Mr. Dixon was born at Milwaukee, Wis., September 11, 1877. He received his education in the common and high schools of that city and at the University of Wisconsin, from which he graduated in 1900 with the degree of mechanical engineer. In the fall of 1900 he entered the employ of the Brooks Works at Dunkirk, N. Y., and served his time in the shops and drawing office. He was later for a while in the mechanical engineer's office, but then went back

to the shops, first as foreman of the cylinder shop, then as assistant general machine shop foreman and finally general in-



J. E. Dixon

spector for the Brooks Works. He was transferred to New York in 1905 and made a salesman of the Atlantic Equipment Company, a subsidiary of the American Locomotive Company. He later became manager, but in February, 1907, was transferred to the sales department of the American Locomotive Company as assistant manager of sales as above noted. As vice-president in charge of sales of the Lima Locomotive Corporation, Mr. Dixon will have headquarters at 50 Church street, New York.

The Economy Devices Corporation, New York, has opened a western office at room 1634, McCormick building, under the management of Joseph Sinkler. Mr. Sinkler has been in the



J. Sinkler

J. H. Guess, who has recently been elected secretary and treasurer of the Lima Locomotive Corporation, was from January, 1912, until recently, general purchasing agent of the Grand



J. H. Guess

Trunk in March, 1902, and in 1905 was made also assistant secretary and assistant treasurer of that company. From September, 1905, to September, 1910, he was general purchasing agent of the National Railroad of Mexico, and its successor, the National Railways of Mexico. Mr. Guess went to the Grand Trunk as assistant general purchasing agent in 1910, and in January as above noted. In addition to being secretary and treasurer, 1912, was promoted to the position of general purchasing agent of the Lima Locomotive Corporation, Mr. Guess will also be in charge of purchases. His headquarters will be at Lima, Ohio.

service of the Franklin Railway Supply Company for nearly twelve years. He was born at Scranton, Pa., December 14, 1874. He began his mechanical career with the Dickson Locomotive Works, Scranton, Pa., with which company he remained three years. He later was in the employ of the New York, Susquehanna & Western for two years and for a succeeding two years in that of the Delaware, Lackawanna & Western. He became associated with the Franklin Railway Supply Co. on July 1, 1904.

J. E. Tesseyman, who recently assumed the duties of general manager of the Youngstown Steel Car Company, successor of the Youngstown Car & Manufacturing Co., as noted in the



J. E. Tesseyman

January number of the *Railway Mechanical Engineer*, was formerly vice-president and general manager of the Ralston Steel Car Company. Mr. Tesseyman was born in Dayton, Ohio. After leaving high school in 1893, he entered the services of the Barney & Smith Car Company, and worked in the machine shop and drafting departments of that organization until 1900. He then went to the Pressed Steel Car Company, and served until 1906 as head of the order department, general storekeeper and head of the cost bureau, respectively. In that year he entered the employ of the Ralston Steel Car Company as general superintendent. After three years in that position he was made general manager, and later vice-president and general manager, which position he held until March, 1914.

John A. Hill, president of the Hill Publishing Company, died suddenly of heart failure on January 24 while in an automobile on his way from his home in East Orange, N. J., to his place of



John A. Hill

business in New York City. Mr. Hill was only 57 years of age; he was born February 22, 1858, at Sandgate, near Bennington, Vt. His parents moved to central Wisconsin and settled at Mazomanie when he was still a boy. He received only a country school education, and at 14 years of age went to work in a country printing office, of which he became foreman three years later. He was also half owner of a machine shop. At 20 he spent about a year prospecting and roughing it in the lead district. He then became a fireman on the

Denver & Rio Grande and after a year was made an engineer. In his spare moments he took the opportunity of studying railway work and mechanics and occasionally, beginning in 1885, contributed articles to the railway engineering department of the *American Machinist*. In 1887 the publishers of that paper, desiring to broaden out into a new field, started the *Locomotive Engineer*. Mr. Hill was invited to New York to become its editor, but after three and a half years in that position he, in company with Angus Sinclair, bought the paper and renamed it *Locomotive Engineering*.

The new paper was a success from the start and two notable series of stories that appeared in it and attracted great attention were "Jim Skeever's Object Lessons" and "Stories of the Railroad," both of which were afterwards reprinted in book form.

Mr. Hill at this time also published "Progressive Examinations for Locomotive Engineers," later adopted by the Master Mechanics' Association as a standard form of examination.

In 1896 the publishers of Locomotive Engineering, desiring to try their hand at a broader field than their paper would permit, acquired the American Machinist. A year later Mr. Hill sold his interest in Locomotive Engineering to his partner, Mr. Sinclair, and became the sole owner of the American Machinist itself. In 1902 he further extended his activities and purchased Power, which at that time was a monthly journal devoted only to the field of power transmission. The paper was at once changed to its present form and in 1908 it became a weekly. In 1905 the Engineering and Mining Journal was acquired, and in 1911 Coal Age was established to cover a field which was too large to be reached successfully by the Engineering and Mining Journal alone. The Engineering News, the fifth paper now owned by the Hill Publishing Company, was acquired in 1912. In the meantime, in 1900, a British company was formed to publish a European edition of the American Machinist. The continued growth of that paper also led its publishers to establish in 1909 the Deutscher Hill Verlag, A. G., which publishes Maschinenbau, a German edition of the paper.

One of the achievements of which Mr. Hill was proudest, however, was the building at Tenth avenue and Thirty-sixth street, New York, which was completed in the latter part of 1914 and now houses the offices and printing plant of the five Hill publications.

Mr. Hill was recognized by all as one of the leaders and big men of the technical publishing field. It was owing to his initiative that many of the things that now give the technical papers their present standing were brought about. He was by nature modest, but he had the winning qualities of being genial, fond of good companionship, a man of force and character. The present high standing of the Hill Publishing Company, which he founded, is the best evidence of his creative and organizing ability.

Oliver C. Gayley, vice-president of the Pressed Steel Car Company, died at his home in New York City, Sunday, January 9. Mr. Gayley had been associated with the company since December, 1902,



O. C. Gayley

since December, 1902, and its vice-president since January, 1910. He was born in West Nottingham, Cecil County, Md., April 9, 1860. In 1880 he entered the engineering department of the Pennsylvania railroad, and remained with that road for eight years. In 1888 he became one of the division engineers of the Philadelphia & Reading, but left railway service two years later to accept a position as general manager of the Kansas City Car & Wheel Company, Kansas City, Mo. He later became general agent of the Missouri Car & Foundry Company of St. Louis, from which position he resigned in April, 1893, to enter the service of the Safety Car Heating & Lighting Company, New York. In December, 1902, he became associated with the Pressed Steel Car Company as manager of sales, eastern district. In October, 1904, he was elected second vice-president, and in January, 1910, became vice-president. Mr. Gayley was also vice-president and a director of the Western Steel Car & Foundry Company, and a director of the Safety Car Heating & Lighting Company.

## CATALOGUES

**CAR DOOR FASTENERS.**—Circular No. 54, recently issued by the National Malleable Castings Company, Cleveland, Ohio, describes and illustrates the company's line of National safety car door fasteners, handles, stops and fittings.

**HORIZONTAL GAS ENGINES.**—The National Transit Company, Oil City, Pa., has issued Bulletin No. 403, describing its horizontal gas engines ranging from 30 to 80 h. p. The book is illustrated with photographs and drawings of the various parts.

**FREIGHT CARS.**—The Ralston Steel Car Company, Columbus, Ohio, has recently issued a loose-leaf binder containing copies of bulletins showing cars which this company has built for various railroads and other owners of freight cars. Each bulletin illustrates one or more cars and gives a very brief description and general information relative to each. The illustrations are extremely clear, and the binder and its contents very attractively gotten up.

**WATER TUBE BOILERS.**—The A. D. Granger Company, New York, has just published Bulletin No. 2, sixth edition, describing its Oswego internally fired water-tube boiler. The bulletin, which is well illustrated, describes the latest improved features of this self-contained internally fired water-tube boiler. Dimensions, ratings and other data are given for both high-pressure and low-pressure boilers, and pictures of the detailed parts of the Vulcan shaking grates are shown.

**FIREPROOF FLOORS AND BEARING PARTITIONS OF PRESSED STEEL CONSTRUCTION.**—This pamphlet issued by the Trussed Concrete Steel Company, Youngstown, Ohio, illustrates the use of a form of fire-resisting construction involving the use of Kahn pressed steel I-beams and H-studs. Fifteen standard sections are provided, of depths varying from 3 to 12 in. and having an appearance somewhat similar to the standard rolled I-beam. They are made of two pressed steel troughs riveted together back to back, the edges of the bases being turned in to a depth of ½ in. The pamphlet illustrates the wide flexibility with which this form of structural material may be applied. In general, it is intended to cover the studs and beams on each side with a metal lath or mesh such as Hy-Rib, to facilitate the application of concrete surfaces.

**INSPECTION AND TESTS.**—The engineering firm of Robert W. Hunt & Co., Chicago, has recently issued a booklet explaining the work of the engineering division of that company's bureau of inspection, tests and consultation. The book goes into some detail concerning the aims of the organization and the duties of its various departmental subdivisions. The company is prepared to make examinations and reports on public utilities, power plants, industrial plants, etc. It may also be called upon for consultation and designing with reference to power plant design, industrial plants and railway equipment. Its construction and testing department, in addition, is in a position to supervise the construction of power and other plants and to supervise also tests of electrical and mechanical apparatus at the manufacturer's works or at the plant after installation.

**CHAIN DRIVES.**—Publication No. 14, recently issued by the Morse Chain Company, Ithaca, N. Y., bears the appropriate title: "A Chain of Evidence." The booklet deals in particular with large power drives. It explains the advantages of silent chain drives and touches upon the superiority of Morse silent chain, mentioning among other things the economies secured through the use of the Morse rocker-joint which differentiates Morse chain from that of other makes. The catalogue contains a number of interesting illustrations, including views of the largest chain drive in the world, a 5,000-hp. Morse drive in the Ox Bow Hydro-Electric Plant, Snake river, Copperfield, Ore., and of the chain drive installation on the 300-hp. McKee gasoline switching locomotive built for the Motley County Railway.



# Railway Mechanical Engineer

Volume 90

March, 1916

No. 3

## Passenger Car Terminal Competition

On page 57 of the February number we announced that we would give a prize of \$35 for the best article and a second prize of \$25 for the next best article on passenger car terminal methods or organization. The article is to be judged from a practical standpoint. Any other articles that are accepted for publication will be paid for at our regular rates. The passenger car terminal forms a most important link in the chain of facilities for the safe operation of passenger trains and caring for the comfort and convenience of the traveling public. There has been very little written on this subject, and we believe that a great deal can be brought out which will be of distinct benefit to car department officers and men throughout the country. It is not necessary for those taking part in the competition to discuss the subject as a whole, or to consider any particular phase of it. Anyone whose experience has been mainly along one special line is quite as likely to win the prize by dealing with that particular phase of the subject in a broad way as one who may endeavor to cover the entire terminal yard question. In order to qualify, the articles must be in our offices in the Woolworth Building, New York, on or before April 1, 1916.

## Horizontal Sheathing on Box Cars

One of the first criticisms that was brought forth in arguments against the outside steel frame, horizontally sheathed box car was that it would be impossible to prevent water from entering the car through the joints of the horizontal sheathing. The promoters and others who favored this type of car have always held that this criticism is without foundation and that no such leakage occurs. This type of car has been built in such large numbers during the past few years that it has been generally supposed that the charge of leakage in this way has been amply disproved. It was therefore surprising to learn recently of well authenticated cases of leakage through the tongue-and-grooved joints of horizontally sheathed box cars to an extent sufficient to cause extensive damage to flour and similar shipments. Moreover it was found that it was not necessary that the water be driven against the side of the car with any force, the action of water running down the side of the car as in a gentle rain being sufficient, as the water passes through the joint apparently by some sort of capillary action. If this condition is general it is likely to seriously affect the future building of this type of car, and it would be interesting to know what the general experience has been of those roads operating cars of this type.

## Increasing the Length of Locomotive Runs

A means for decreasing the total fuel consumption of road locomotives that has not been given the consideration it deserves by the railroads of this country is the practice of running the same locomotive over two successive divisions. Reports that have sometimes been printed regarding this practice show that it is thoroughly practical

and that a substantial saving in fuel can be made. It has been reported that over 30 per cent of the fuel consumed by road locomotives is burned at the terminals. What better argument can be advanced for cutting out one of these terminal delays for any through locomotive run? Tests on the Lehigh Valley showed that by running a passenger train through from New York to Buffalo with one engine a saving of practically 50 per cent in the coal consumed by the engine was made. The Great Northern runs some of its engines over 400 miles without change. Other roads have also increased the length of their engine districts, and found it profitable from a fuel standpoint.

In some cases operating difficulties have arisen to the extent that this practice has been regarded as inexpedient. When this is the case, however, a very careful analysis should be made, for perhaps a change could be made in the operating conditions which would cost less than the amount saved in fuel by running the engine over two divisions.

## What is Heat-treated Steel?

Special steels will undoubtedly be used in large quantities for locomotive parts within a comparatively short time; in fact, heat-treated steel and some alloy steels are being more generally used all the time. Unfortunately a great many railway blacksmiths have not been trained in the methods of handling such steels and they will require a considerable amount of education along these lines. With a view to bringing out the best practice in dealing with heat-treated steel, we will give a first prize of \$35 and a second prize of \$25 for the two best articles, judged from a practical standpoint, on "What heat-treated steel is and how it should be handled." The articles must be received in our offices in the Woolworth Building, New York, on or before May 1, 1916. For any articles which do not receive a prize but are deemed worthy of publication, we will pay our regular space rates. It is desired to bring out in this competition facts concerning heat-treated steel and its use which will be of direct value and assistance to smith shop foremen in their work. While a certain amount of theoretical discussion may be necessary, it should be confined as closely as possible to such essentials as directly affect practice. This is an opportunity for those who are familiar with the forging and heat-treating of this material to greatly assist those others who have as yet had no experience with heat-treated steel but who are likely to have at any time and therefore should be prepared for it.

## The Reinforcing of Underframes

There are a great many wooden freight cars being equipped with steel reinforcements of one kind or another in the underframing. Some of these reinforcing structures are well designed, and so applied that they strengthen the old underframe and adequately protect the car from severe shocks; but there are some of them that are not reinforcements, but trouble makers. There is no use in applying to a wooden car two light steel sills inadequately

attached to the old underframe. Even if they are substantially connected to the body bolsters it has been found that instead of adding to the strength of the wooden center sills these light steel sills will buckle and spring away from the wood sills. Again when these light steel sills are used they are seldom supported properly at the end sill, with the result that in a very short time they begin to crack or bend at the body bolster and the outer end consequently drops so that the coupler is below the standard pulling height. When steel sills of this nature have been repaired because of the troubles indicated above the work is much more difficult and expensive than it would have been to repair the original wooden underframe. Experience has shown that the wooden underframe would have been almost, if not quite as strong without this so-called reinforcement. If our old freight equipment is to be made suitable for operation in present-day trains, the reinforcing structure for the underframe must be more reasonably designed and better applied than in a large number of cars that have been rebuilt in the past few years.

**Design of New Equipment** In the designing of new equipment the mechanical engineer can be most ably assisted by the men who are to repair and maintain it after it has been built. On the Chicago, Rock Island & Pacific definite action is taken before the final drawings and specifications are submitted to the builders. If an entirely new design is planned the drawings are made in the mechanical engineer's office and sent to the mechanical superintendents of the various divisions who, with their subordinates, including the general foremen and inspectors, make a careful study of the design and either approve or recommend changes which would be desirable according to their experience. The plans are then returned with the criticisms and the matter considered in a staff meeting of the general mechanical officers. In the case of the contemplated purchase of cars from designs that have previously been used, the same procedure is followed and in this case the men, having actually handled the equipment, are in a position to state definitely just what changes should be made.

At the general meeting, if there should be a conflict of opinion the disputed points are thoroughly discussed and a vote taken as to which practice shall be followed. By this means it is possible to bring theory and practice together with the best possible results. When the equipment is placed in service the men on the firing line are extremely interested in its performance. They feel that they have had a hand in its design. They are constantly watching to see what can be improved so that they may make suggestions the next time they are called upon to pass on new equipment. They are not only educating themselves but giving the company the benefit of their experience. It is a plan that has worked out in a highly satisfactory manner and one that more closely knits the relationship of the repair and construction forces.

**The Enginehouse Competition** On another page of this number will be found the prize article in the enginehouse competition which closed February 1. There were twelve articles received, all of which have sufficient merit to warrant our using them in whole or in part, but the judges considered that that by E. W. Smith was the one most worthy of the prize. The organization described by Mr. Smith is that for a very large enginehouse and it has been successfully used for some time at two large terminals, one handling freight locomotives and the other passenger. While it is not expected that everyone will agree with his ideas, there is no doubt that there are many features of the methods employed at these two terminals which would be of value if followed at other points. For instance, there might be mentioned the practice followed as regards inspectors. The lines of their work are laid down in

such a way that there seems to be sufficient flexibility to the organization to insure the most efficient carrying out of both the inspection work and the light repair work. Mr. Smith's reasoning as outlined in the portion of the article dealing with discipline is also worthy of special consideration, one of the most important parts of this being the reference to a system of organization that provides each man with a day off during the week and at the same time a man who is thoroughly familiar with his work to take his place. One of the worst features of many enginehouse organizations is that if a man who has any special work assigned to him lays off, his work either has to be left undone or is done indifferently till his return. The practice outlined in the article follows the system which we have frequently advocated of having at least two men who are capable of taking charge of any particular line of work.

**Organization and Low Maintenance Costs** The superintendent of motive power of a road that has been especially successful in securing low unit maintenance costs and a small number of engine failures was asked one day for the secret of this success. He disclaimed any credit for the good performance, passing all of it on to his subordinates, stating that they have all been with him on the road long enough to know that what he wants is *results*. They are given a free hand in their work and as much "red tape" as possible is eliminated. If they need more help or decide to discharge some, it is unnecessary for them to consult him. They are expected properly to maintain the equipment at the lowest possible cost in keeping with a high degree of efficiency. He stated further that he, personally, has so little work to do that he is almost ashamed to draw his salary!

This man has capitalized his personality and undoubtedly is worth more money than he is getting. He won the confidence of his men by treating them fairly; he won their respect by demanding results. He gets their co-operation by treating them as human beings, giving them all the right to their own opinions. "Frequently," he says, "we have heated discussions which to an outsider would appear as rank disruption, but we get all the arguments from which the final policy is determined. I would discharge a man who would agree with me against his honest convictions." Is it any wonder that that mechanical department succeeds? It is organized along human lines. The men are made to feel that they form an important part of the organization. It is a close organization—one large family; they are sure of fair treatment; they are contented. They make their efforts count and produce results.

**Maintenance of Steel Cars** There has never been a more complete discussion of the problems involved in the use of steel cars than in the article written by M. K. Barnum and published elsewhere in this issue. Mr. Barnum has made a special study of this question and, from the experience gained from steel cars that have been in service for a number of years, has been able to present important facts regarding the life of this class of equipment and make valuable suggestions concerning its maintenance and repairs. The open steel freight cars, having been in more general use than any other type of steel car, present the greatest field for investigation. The lessons learned from them are, however, of value in solving the problems of all steel cars. When the steel cars were first thought of and actually built they were considered to be almost a panacea for all freight car troubles. By their use it was possible to increase the length of trains. Being built of steel they were expected to withstand the roughest kind of handling. Also their life was considered to be almost indefinite. As a result they were placed in service with an over-estimated value of their usefulness. They were allowed to

run with but little thought regarding their maintenance. Experience has shown the fallacy of these ideas, and brings home to the owners the disappointing fact that the steel cars are not the "immortals" they were once supposed to be.

It is not intended to imply that the steel cars are a mistake or even an expensive luxury. They are a positive necessity on the modern railroad. They are needed, and do their part in reducing transportation expenses. The savings thus accomplished, however, must not be neutralized by the rapid depreciation of these cars due to the lack of proper maintenance. They must be protected from corrosion and they must be built so that the parts subjected to the severest service can be readily renewed. Mr. Barnum shows how steel bridges and locomotive tenders have been made to last for 25 or 50 years by keeping them well protected with paint. He presents photographs of the outside of gondola cars in a badly rusted condition from the lack of paint, and states that, owing to the almost impossible task of keeping the inside of these cars painted, the managements of some roads claim that it is a waste of money adequately to protect the outside. Whoever follows this practice is, in fact, burning the candle at both ends, for a steel plate which is subjected to corrosion on one side only, will last longer than if it is allowed to rust away on both sides. Nor are the sides the only parts of the car neglected. Illustrations used in Mr. Barnum's article show what is to be expected when the underframe is not properly protected from corrosion.

The statement is made by Mr. Barnum that some railway men claim that the best means of preserving the interior of the open steel cars is to keep them in service. There are times, however, when it is necessary to store these cars. Why not thoroughly clean them and give them a coat of the "No. 4 Mixture" mentioned by Mr. Barnum as being recommended by the Master Car Builders' Association? The steel cars are with us to stay, and they must be maintained. Their first cost is greater and their maintenance cost is greater than those of the old wooden cars, but they earn more. They will produce even greater returns if they are given proper care.

Road Conditions and Locomotive Types

We were recently asked what we had done to popularize the 2-10-2 type locomotive. We doubt very much whether it would be advisable to try to popularize any type of locomotive. Experience has shown that when a new type of locomotive is introduced it is more than likely to be ordered in a great many cases more because it is "popular" than because it is the most suitable type for the service required. We are not trying to detract from the value of the work that is being done by locomotives of the Santa Fe type on several roads, nor is it the intention to urge the general adoption of some other type instead. Locomotives of this type are giving excellent results in a number of cases on roads where the character of the traffic and the road conditions make them admirably suited for what is required, but because of this success there appears to be a very general idea that multiple-axle locomotives are "in style" and therefore should be ordered when new power is required, regardless of whether conditions warrant it or not. There has been too much "popularizing" of locomotive types in the history of American railroading and it is high time that railway men realize that economy and efficiency in train operation require the employment of locomotive types which are suited to the conditions which are to be met.

Of course, the final decision may be that the type best suited to the work is the 2-10-2 or a similar type. As stated above, we have no fault to find with a decision of this character. There may even be cases where the condition of a road's finances would justify, from the standpoint of economy, the purchase of multiple-axle locomotives of comparatively light weight per axle rather than to go to the expense of rebuilding track and bridges so that heavier axle loads

could be used with smaller locomotives in increasing the average train load. The point we have in mind does not have reference to such conditions as these but to the indiscriminate purchase of a popular type of locomotive simply because it has proved efficient on another road where the physical characteristics and the traffic conditions may be quite different.

There is another feature connected with the purchase of large locomotives which even some of the larger roads have not considered any too carefully. The cost of locomotive repairs is increasing; this seems quite natural when we consider the increases in wages and the increase in the size of locomotives during the past few years, but there are many instances where large locomotives have been purchased with little or no consideration being given to the facilities available for repairing them, and without adequate shop and enginehouse facilities the cost of maintenance of the large locomotive is going to be greater than it would be if proper facilities were provided. We are all familiar with the inadequate roundhouse which necessitates the leaving open of the doors on stalls occupied by modern engines because of 10 or 15 feet of the tender being still outside the house when the locomotive is under the smoke jack. The repair facilities of such an enginehouse are invariably on a par with this condition, and when one considers the cost of removing and repairing heavy parts of a modern locomotive under such conditions, the feeling is one of amazement at the shortsightedness of a policy that provides heavy locomotives without any consideration being given to the repair facilities. The roundhouse is not the only place that has been outgrown by the locomotive. There are many roads which are no better off as regards main repair shops. Efficient, economical repair work cannot be done on a modern locomotive by machine tool equipment that was intended for the repairing of the American and Mogul type engines of 25 or 30 years ago.

We have endeavored in the foregoing to lay special stress on the importance of two points: First—Consider traffic and physical conditions carefully and choose a type of locomotive that is suited to them. Second—Be sure that the shop and terminal facilities are capable of economically repairing and handling the engines after they are purchased.

#### NEW BOOKS

*Proceedings of the Twenty-third Annual Convention of the International Railway Master Blacksmiths' Association.* Size, 6 in. by 8½ in., 226 pages. Bound in cloth. Published by the Association, A. L. Woodworth, Secretary, Lima, Ohio.

This volume contains a complete account of the proceedings of the last annual convention of the International Railway Master Blacksmiths' Association, which was held at the Hotel Walton, Philadelphia, Pa., August 17-19, 1915. Among the subjects discussed were flue welding, frog, switch and crossing work, carbon and high-speed steel for tools, tools and formers, reclaiming scrap, and shop kinks. The volume contains a fund of information on these subjects which will be found of value to many blacksmith foremen.

*Oxy-Acetylene Welding and Cutting, Electric and Thermit Welding.*—By Harold P. Manly. Bound in cloth. 209 pages, 4¼ in. by 6¼ in. Illustrated. Published by Frederick J. Drake & Company, Chicago.

This book should prove of value to anyone concerned in metal working. Its size has been kept small but the range of subjects and the details covered is very complete. The chapters include discussions of the heat treatment of metals; welding materials; acetylene generators; welding instruments and a general discussion of the practice in both oxy-acetylene and electric welding. There are also chapters devoted to hand forging and welding as well as soldering, brazing and thermit welding. The illustrations are particularly clear and show the various types of equipment in considerable detail.

# PULVERIZED FUEL FOR LOCOMOTIVES\*

## The Economic Advantages of Pulverized Fuel; Essential Features of the Locomotive Equipment

BY J. E. MUHLFELD

President, Locomotive Pulverized Fuel Company

For the purpose of quickly conveying to you my reasons for believing that the burning of solid fuels in a pulverized form is the most promising solution of our fuel problems, and that it will become the generally adopted method for generating power in steam locomotives, the following facts and conclusions are set forth:

First.—The present annual consumption in the United States of about 7,000,000 tons of solid fuel in pulverized form, in industrial kilns and furnaces, has demonstrated the effectiveness and economy of this method of combustion.

Second.—The expenditure for locomotive fuel is, next to labor the largest single item of cost in steam railway operation. The Interstate Commerce Commission reports that this expense for the fiscal year ending June 30, 1915, was \$249,507,624, or about 23 per cent of the transportation expense of 242,657 operated miles of steam railways in the United States.

Third.—The necessity for conserving the limited supply of oil in the rapidly exhausting fields, for other than locomotive purposes, will shortly eliminate it from railway motive power use.

Fourth.—Present requirements for reliable and flexible motive power of relatively low first cost, and expense for fixed charge, maintenance and operation, precludes the use of internal combustion, compressed air, hot water, storage battery, and electric locomotives dependent upon an outside source of power, for the general movement of heavy traffic.

Fifth.—The quantity of steam used by the modern locomotive necessitates high rates of evaporation, and this can only be obtained economically by some means for burning solid fuel other than on grates, in order to reduce the waste of coal containing a large percentage of dust and that from imperfect combustion, to eliminate fire hazards, to conserve cylinder tractive efforts and to improve the thermal efficiency of the locomotive as a whole.

Sixth.—Shallower seams of coal; mechanical and powder methods of mining; greater security demanded for labor; the high cost for developing, tunneling, timbering, pumping, ventilating and inspecting mines; scarcity of, and higher wages for labor, and more rigid legislative rules and regulations will rapidly increase the cost for solid fuels.

Seventh.—Proper co-operation between the railways and the mine operators will necessitate that the former shall make use of the constantly increasing percentage of dust, slack, screenings, and other small sizes of gas, soft and anthracite coals, as well as of coke breeze, lignite and peat which cannot now be effectively or economically burned on grates in locomotives.

Eighth.—Steam locomotives must be equipped to more nearly approximate the electric locomotives as regards the elimination of smoke, soot, cinders and sparks; reduction of noise, time for despatching at terminals, and stand-by losses, and to increase the daily mileage by producing longer runs and more nearly continuous service between general repair periods.

Ninth.—Labor of a higher average standard should be induced to enter the service as firemen by reducing the arduous work now required to fire modern steam locomotives of great power.

Tenth.—The future steam locomotive will be required to

produce the maximum hauling capacity per unit of total weight, at the minimum cost per pound of drawbar pull, and with the least liability for mechanical delay.

These conditions as outlined can generally be met through the use of pulverized fuel. Its use offers opportunity for even greater accomplishment in the steam railway field than has been obtained through its use in cement kilns and metallurgical furnaces. A saving of from 15 to 25 per cent in coal of equivalent heat value fired, results from its use as compared with the hand firing of coarse coal on grates. As pulverized fuel may run as high as 10 per cent in sulphur and 35 per cent in ash and still produce maximum steaming capacity, and as otherwise unsuitable and unsalable or refuse grades of fuel may be utilized, the saving in first cost per unit of heat will be a considerable additional item. The most severe test\* that has yet been made was with some semi-bituminous coal from Brazil, South America, analyzing when pulverized:

Moisture .....	from 2 per cent to 8 per cent
Volatile .....	from 14 per cent to 28 per cent
Fixed carbon .....	from 58 per cent to 34 per cent
Ash .....	from 26 per cent to 30 per cent

The sulphur averaged from 3 per cent to 9 per cent and the heating value from 10,900 B. t. u. to 8,800 B. t. u. No difficulty whatever obtained in maintaining maximum boiler pressure when working the locomotive with this fuel under the most severe operating conditions.

The use of pulverized fuel enables firebox temperatures and sustained boiler capacities to be attained equivalent to and exceeding those obtainable with crude or fuel oil. It eliminates waste products of combustion and fire hazards, and permits the enlargement of exhaust steam passages, thus producing increased efficiency of the cylinders. Pulverization permits the use of such fuel as cannot readily be disposed of by mine operators in the commercial trade, and provides for the utilization of existing refuse, and of lignite and peat. It renders possible the elimination of smoke, soot, cinders and sparks, and increases the time available for transportation use. It dispenses with the necessity for grates, ashpans and trailing trucks, thereby increasing the percentage of total locomotive weight available for the development of drawbar pull.

Commencing with Richard Trevithick's locomotive, which was built in 1803, and was the first to actually perform transportation service, the general practice has been to burn wood, coal and other solid fuels in locomotive fireboxes on grates. However, during the past twenty-five years the continued advance in locomotive tractive effort has so increased the required rate of combustion that the quantity of fuel now used per unit of work performed is far beyond what a more effective means will produce. While great progress has been made in the superheating and use of the steam, the principal improvements that have been perfected in steam generation have been through the enlargement of heating surfaces, better circulation of water, regulation of air admission and the use of fire-brick arches. The locomotive boiler is responsible for, and involves the greatest proportion of inspection, cleaning, maintenance, liability for damage, and expense that obtains in the operation of steam railway motive power, but it has probably received the least consideration as regards improve-

\*For a discussion of the results of tests with pulverized fuel in locomotive service see the *Railway Age Gazette, Mechanical Edition* for May, 1915, page 213.

\*From a paper presented before the New York Railroad Club, February 18, 1916.

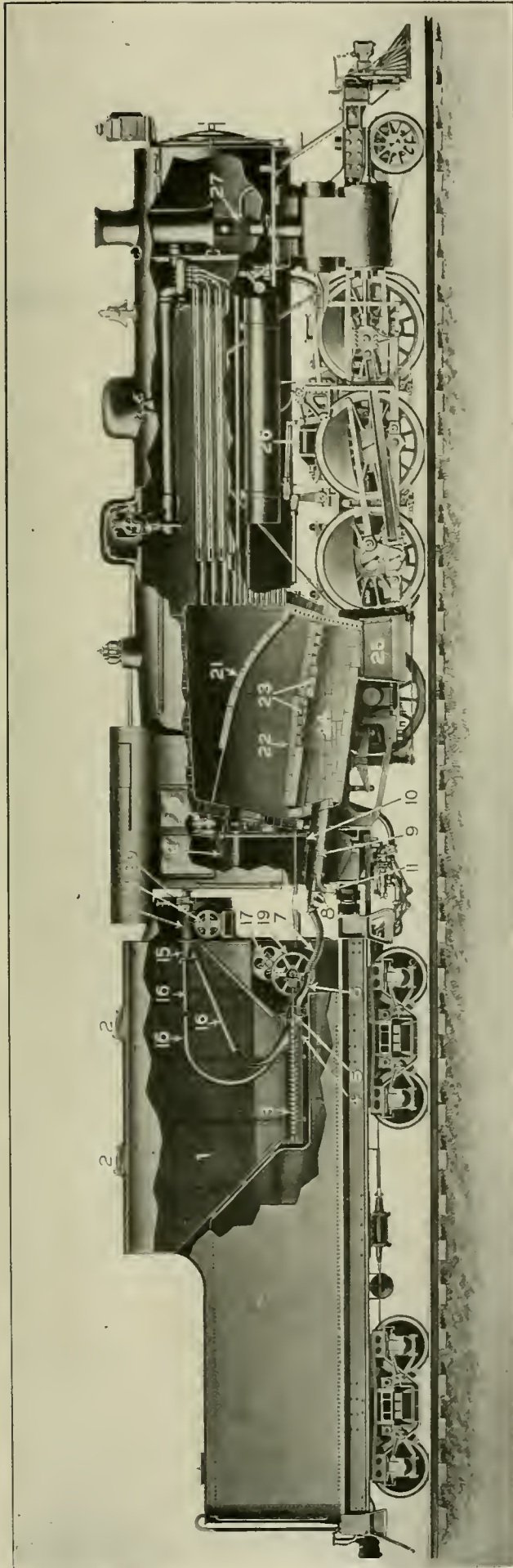

Locomotive Equipment for Burning Pulverized Fuel—See Table for Names of Parts

ment in its general efficiency. Today it is subjected to the most criticism from the general public as the result of the smoke, soot, cinders, sparks, ashes and noise that it produces.

Experimenting with coal dust for fuel dates as far back as 1818, although its actual industrial application in the United States did not begin until 1895, when the advance in the price of fuel oil led to its use in cement plants. The Manhattan Elevated Railroad in New York City made some experiments with the use of coal dust in one of its locomotives about fifteen years ago, the pulverizing of the fuel and the discharge of air and fuel into the firebox being accomplished by the use of a combined pulverizer, blower and steam turbine located on the locomotive. However, in this case the cylinder exhaust was not used to produce boiler draft, the coal dust was relatively coarse and no provision was made for precipitating and cooling the furnace slag, all of which no doubt contributed to the disuse of the equipment. The Swedish government railways have also done some experimental work in the burning of peat and coal powder in small steam locomotive boilers during the past few years, the fuel being prepared before supplying to the locomotive tender. In this case the powder is blown into the furnace by steam, and the firebox brick work is very complicated.

The first steam railway locomotive of any considerable size to be fitted up in the United States or Canada and so far as is known, in the world, with a successful self-con-

NAMES OF PARTS OF PULVERIZED FUEL EQUIPMENT

1. Enclosed fuel container.
2. Fuel supply inlets and covers.
3. Fuel conveyor.
4. Fuel and pressure air feeder.
5. Fuel and pressure air commingler.
6. Fuel and pressure air outlet.
7. Fuel and pressure air flexible conduit.
8. Fuel and pressure air nozzle.
9. Fuel and air mixer.
10. Firing up opening.
11. Induced air inlet diameter.
12. Control for induced air inlet damper.
13. Pressure blower.
14. Steam turbine or motor for pressure blower.
15. Pressure blower manifold.
16. Pressure blower conduits.
17. Steam turbine or motor for fuel conveyor, feeder and commingler.
18. Control for steam turbine or motor for fuel conveyor, feeder and commingler.
19. Operating gear, shaft and clutches for fuel conveyor, feeder and commingler.
20. Switchboard (when electrical equipment is specified).
21. Brick arch.
22. Primary arch.
23. Auxiliary air inlets.
24. Combustion furnace.
25. Self-clearing air cooled slag pan.
26. Turbo-generator (when electrical equipment is specified).
27. Combination engine and turbo-generator exhaust nozzle and stack blower.

tained equipment for the burning of pulverized fuel in suspension, was a ten-wheel type on the New York Central. This locomotive has 22-in. by 26-in. cylinders, 69-in. diam. drivers, 200-lb. boiler pressure, 55 sq. ft. grate area, 2,649 sq. ft. heating surface, and has a tractive effort of 31,000 lb. It is equipped with a Schmidt superheater and Walschaert valve gear and was first converted into a pulverized fuel burner during the early part of 1914. Since the development of that application another similar installation has been made on a Chicago & North Western existing Atlantic type locomotive, and also on a new Consolidation type locomotive recently built for the Delaware & Hudson at the Schenectady works of the American Locomotive Company. This locomotive is probably the largest of its type in the world, as it has 63-in. drivers and about 63,000 lb. tractive effort, having been designed for combination fast and tonnage freight service.

This development has now passed the experimental stage, and arrangements have been made for proceeding with commercial applications as rapidly as the equipment can be produced. The general features of the equipment are shown in the illustrations and the method of introducing the fuel and air into the firebox will be understood from a study of the

names of the parts and the reference numbers on the sectional view of the equipment.

In the development of this apparatus the purpose has been to produce an equipment that will be readily applicable to either new or existing steam locomotives of standard designs; to standardize the various details and make them interchangeable for the different types and sizes of locomotives; to eliminate complicated mechanism for conveying fuel from the tender to the engine, and remove all special apparatus except fuel and air supply control levers, from the cab, and to insure positive control over the fuel feed, in order to quickly meet all conditions of road or terminal operation, and to provide for quick firing up. The entire regulation of combustion is effected through three hand control levers in the cab, i. e., fuel feed, air supply, and induced draft, the latter for use when the locomotive is not using steam. A refractory furnace is provided and so arranged that it insures ready accessibility to all parts of the firebox for inspection and maintenance. The fuel is carried in an enclosed container to insure a supply of dry fuel under all conditions of weather. The burning and storage equipment is designed to be readily convertible for the use of fuel oil.

In the application of the equipment to existing types of steam locomotives the diaphragm, table and deflector plates, nettings, hand holes and cinder hopper are removed from the smoke box and the exhaust nozzle opening is enlarged. The grates, ashpan, fire doors and operating gear are removed from the firebox, and a fire-brick lined firepan, slagpan and primary arch, together with the fuel and air mixers and nozzles, are installed. The usual arch tubes and brick arch are utilized. In the cab the fire door is replaced with a furnace door and the fuel and air supply regulating levers are installed. The tender equipment includes the enclosed fuel container and the apparatus for feeding, mixing and discharging the fuel and air, together with the steam turbine or motor operating mechanism. The engine and tender connections consist of one or more hose which connect the fuel and pressure air outlets on the tender to the nozzles on the engine. Flexible metallic conduits are used to convey the fan and fuel feeding motive power.

For firing up a locomotive the usual steam blower is turned on in the stack, a piece of lighted waste is then entered through the firebox door opening and placed on the furnace floor, just ahead of the primary arch, after which the pressure fan and one of the fuel and pressure air feeders are started. From 45 to 60 minutes is ordinarily sufficient to get up 200 lb. steam pressure from boiler water at 40 deg. Fahrenheit.

The prepared fuel, having been supplied to the enclosed fuel tank, gravitates to the conveyor screws, which carry it to the fuel pressure air feeders, where it is thoroughly commingled with and carried by the pressure air through the connecting hose to the fuel and pressure air nozzles and blown into the fuel and air mixers. Additional induced air is supplied in the fuel and air mixers, and this mixture, now in combustible form, is induced into the furnace by the smokebox draft. The flame produced at the time the combustible mixture enters the furnace obtains its average maximum temperature, from 2,500 to 2,900 deg. F., at the forward combustion zone under the main arch, and at this point auxiliary air is induced by the smoke box draft to finally complete the combustion process. The uniformity with which locomotives can be fired, is indicated by the fact that the regularly assigned firemen can maintain the steam within a variation of two pounds of the maximum allowable pressure, without popping off. As each of the fuel and pressure air feeders has a range in capacity of from 500 to 4,000 lb. of pulverized fuel per hour, and as from one to five of these may easily be applied to the ordinary locomotive tender, there is no difficulty in meeting any desired boiler and superheater capacity.

The smokebox gas analysis will average between 13 and 14 per cent of  $\text{CO}_2$ , when coal is fired at the rate of 3,000 lb.

per hour, between 14 and 15 per cent at the rate of 3,500 lb. per hour and between 15 and 16 per cent at the rate of 4,000 lb. per hour, so that as the rate of combustion increases, there is no falling off in the efficiency, as obtains when coarse coal is fired on grates. The waste of fuel from the stack where coal having a large percentage of dust and slack is used, the lowering of the firebox temperature and draft, due to opening the fire door and the resultant variation in steaming and general results under high rates of burning fuel on grates where all of the foregoing factors are involved, are eliminated.

The liquid ash runs down the underside of the main arch and the front and sides of the forward combustion zone of the furnace and is precipitated into the self-clearing slagpan, where it accumulates and is air-cooled and solidified into a button of slag which can be dumped by opening the drop bottom doors.

As in the case of all mediums for producing mechanical power that are now used to bring about the most advanced and progressive results, such as naphtha, gasolene, kerosene, crude and fuel oils, compressed air, storage batteries and electricity, there is a certain element of danger in the use of pulverized fuel that does not obtain with the more ineffective coarse coal. However, there are now certain established rules and regulations governing the manufacture, storage, handling and use of pulverized fuel, which make it comparatively easy to avoid trouble, this being confirmed by the records of the industrial plant operations where ordinary care is exercised.

As in the case of electric locomotives, but little actual operating data is as yet available. The first complete installations of fuel drying and pulverizing plants and locomotive coaling stations, in combination with locomotives equipped for burning pulverized fuel, will be made by the Delaware and Hudson and the Missouri, Kansas and Texas, and these are not yet ready for operation. The locomotives so far equipped on other railways are still depending upon outside or inadequately equipped sources for their supply of pulverized fuel, which makes the handling somewhat difficult. However, in the locomotive operation to date, it has been definitely demonstrated by the results obtained in road passenger and freight service, that the facts and conclusions previously set forth are fully justified.

#### DISCUSSION

M. C. M. Hatch, Superintendent of Fuel Service, Delaware, Lackawanna & Western.—The railroad coal supply of this country now costs a great deal of money, and prices, as well as we may predict, will rise. We cannot, on grate equipped engines, use with satisfaction poorer grades of fuel than we now use. Our fuel charges are bound to go up unless some method other than that now generally used is developed. Pulverized fuel seems to offer the best solution, so far as can now be seen; oil is prohibitive in cost, except in a few parts of the country. In our mining districts are many thousands of tons of refuse, rejected as unsuitable for fuel but still containing much heat value. Endeavors to utilize this refuse in the form of briquettes have been made but with questionable results, at least in locomotive service. Pulverized fuel may prove an outlet for this waste material.

"Stand-by" losses of all kinds aggregate about 25 per cent of the total fuel consumed. If these can be reduced considerable savings will result. Engine divisions are restricted in length by the distance fires can be run satisfactorily. If we can lengthen them or increase the percentage of time during which an engine can be kept in actual service, our charges will be decreased. Flexibility in steam making should be attained to meet all operating requirements. If we can have this our service will be improved. We are trying as best we may to meet these conditions, but there are, at present, limits beyond which we cannot go, and the use of pulverized fuel may prove to be the solution of these difficulties.

My experience with oil burning locomotives has shown that it is not practicable to run a much larger nozzle when using oil than with coal. It seems to me that the combustion of pulverized coal, in suspension, will approximate oil burning conditions, and yet I understand that the nozzle can be increased in area very greatly. I should like to have this explained.

Following are some extracts from a letter from a correspondent in Chicago, the engine referred to being the Atlantic type on the Chicago & North Western, which Mr. Muhlfeld mentioned: "Some time ago you wrote me inquiring about the Chicago & North Western pulverized fuel locomotive. I had a ride on it the other day and was very much impressed with its performance. The fireman seemed to have as good control of the boiler pressure as the engineman had of the speed.

"The engine is of the Atlantic type and had 3-in. safety

oughly consumes the coal while on the road. After the engine has stood awhile at the terminal a little smoke will be produced on starting, inasmuch as the temperature has not been raised sufficiently to insure immediate combustion, but the smoke is practically negligible and the practice may be considered smokeless.

"While it is desired to use the pulverized fuel with only two per cent moisture, I believe the engine that day was operating with coal having five or six per cent. That is another reason for producing a little smoke when the temperature of the firebox is not at the highest point. With the Illinois coal they find that a little honeycomb forms on the tube sheet and has to be removed at the end of each trip. This is done with a rod through a hole in the side of the firebox. With the Eastern coals I understand that this trouble is not experienced. On this trip the operation was entirely dustless in the cab, although I believe a little dust might be expected.

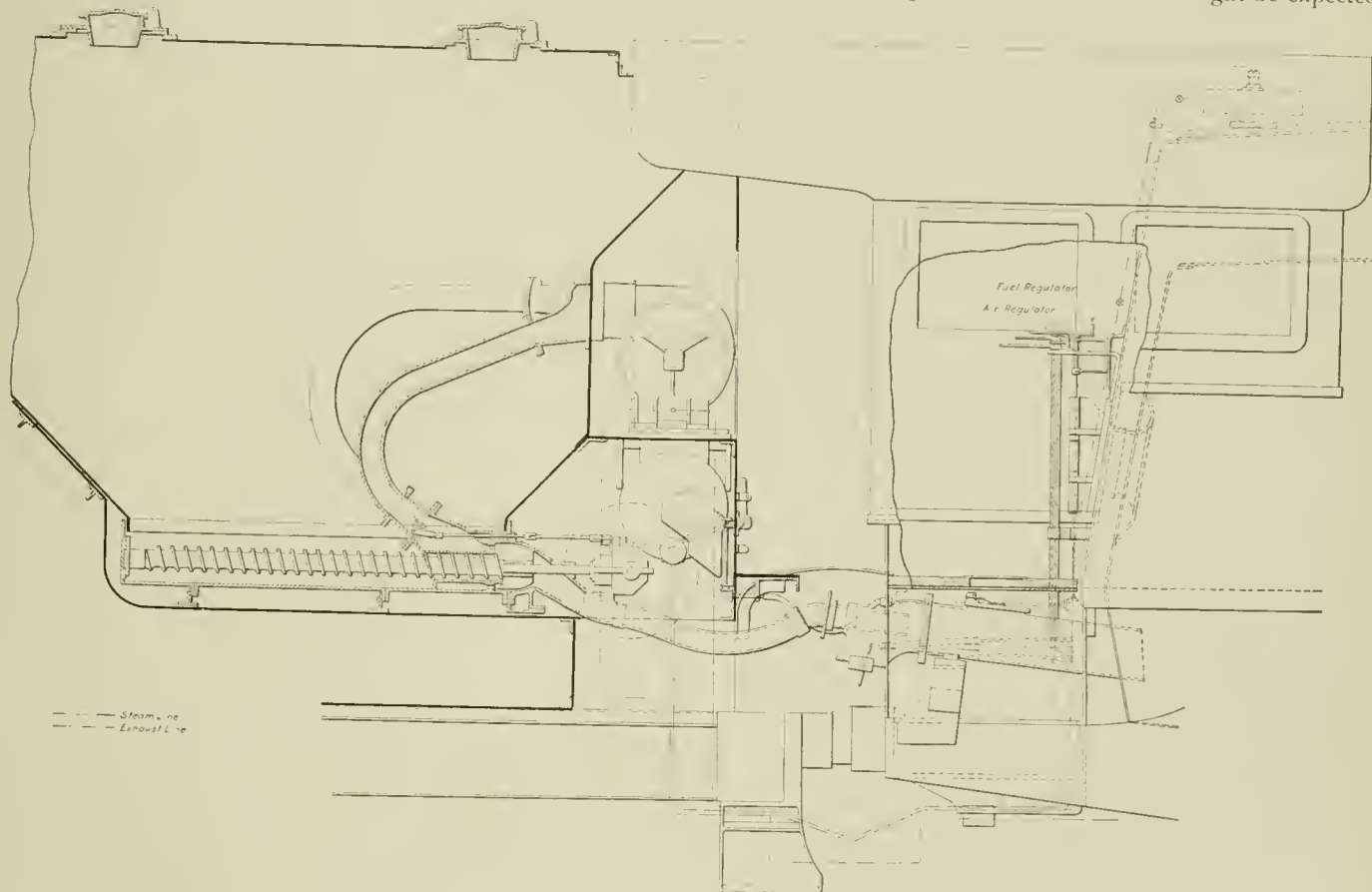

Arrangement of Pulverized Fuel Burning Equipment with Steam Turbine Drive

valves. During the trying-out period these were increased to 3½ in. and then to 4 in., as neither the 3½ nor the 3-in. valves could take care of the pressure. This engine is equipped with three burners, and on this run, which was a suburban run from Chicago to Waukegan, only two were used. The fireman controls the amount of fuel burned by means of a rheostat, which controls the speed of the screw conveyor that feeds the coal to the firebox. He would anticipate the engineer by 15 or 20 seconds in closing the throttle, reducing the fire to practically nothing, and by careful manipulation he did not permit the opening of the safety valves once during the trip. There was a layover of an hour and a half at Waukegan and the fire was put out entirely for about three-quarters of an hour. About a half-hour before leaving time the pressure had dropped to about 150 lb., and one burner was started, the fuel igniting from the heat of the arch and other brick work. The pressure was raised to 185 lb., the working point, in due season for starting. A very high temperature is obtained in the firebox which thor-

From an operating standpoint the scheme seems to be a great success."

In closing the discussion Mr. Muhlfeld said that the average cost for briquetting coal is from 75c. to \$1 per ton and the average cost for pulverizing is 11c. per ton; the pulverized coal does not have the objectionable features as to combustion that briquettes do.

Considerable experimenting has been done to determine the best size of exhaust nozzle to use when burning pulverized fuel and while these experiments are not yet complete, it is probable that an increase in nozzle area of 25 per cent over that used in hand firing will prove to be the most advantageous.

The Delaware & Hudson engine, which is the one shown in the illustration, is to use pulverized fuel obtained from tailings which pass through a 3/32-in. mesh screen. They are easily dried and have a heat value of 12,000 B. t. u. per ton. It is not yet known what proportion of this quality of coal can be used. It is probable that there is no saving in total

weight in the Delaware & Hudson locomotive but some of the weight is transferred to the tender.

Replying to questions, Mr. Muhlfeld said that the collection of slag on the back tube sheet is due to incorrect combustion conditions and that adjustments can be made to eliminate this. Experiments are now being made to determine the best combination of conditions to avoid this accumulation. The pulverizing of the coal for locomotive use is best done at the coaling stations, as it is not practicable to haul pulverized coal in any large quantities in cars and store it for future use.

## GRAPHITE IN LOCOMOTIVE VALVE CHAMBERS AND CYLINDERS

BY M. C. M. HATCH

Superintendent Fuel Service, Delaware, Lackawanna & Western, Scranton, Pa.

Two sources of power loss other than those of a strictly thermodynamic nature, occur within the cylinders and valve chambers of a steam locomotive. These are sliding friction between the packing rings of the piston and valve and the surfaces against which they work, and leaks or "blows" past the packing rings. The first of these, except under extraordinary conditions, is not of very great moment, probably approximating not more than 2 per cent of the indicated power of the engine. This, of course, assumes good lubrication; dry cylinders and valves will increase this amount very

conditions being kept constant, the less will be the friction loss between them. Any machined surface has more or less roughness and if some medium can be used which will smooth up this roughness to an appreciable degree, lubrication will be improved. Graphite properly applied will do this, giving the surfaces a glazed finish and affording the fluid lubricant fed to them a better opportunity to do its work effectively.

"Blows" are the result of scratches or scorings in cylinders, valve bushings or packing rings, which allow the leakage of steam from a zone of high pressure to that of lower pressure. Here again graphite tends to fill up these scores and, consequently, to reduce the leakage loss. This action always follows the use of graphite, no matter whether the blows are great enough to manifest themselves as a roar at the stack or are practically infinitesimal in magnitude. In the following table are shown the results of some valve leakage tests which were included in a report presented before the American Railway Master Mechanics' Association in 1904. These tests were made after the engines had been in service for varying periods, the worst performance recorded having been made after a service of 39,000 miles:

Type of valve and number tested	Leakage in pounds of water per hour		
	Least	Greatest	Average
Piston, 14 locomotives.....	268	2,880	1,208.99
Slide, 11 locomotives.....	384	2,610	1,224.54
Average, all valves tested.....	...	.....	1,215.83

On the basis of these tests it was estimated that the average loss in coal for each engine, ten hours a day, evaporation

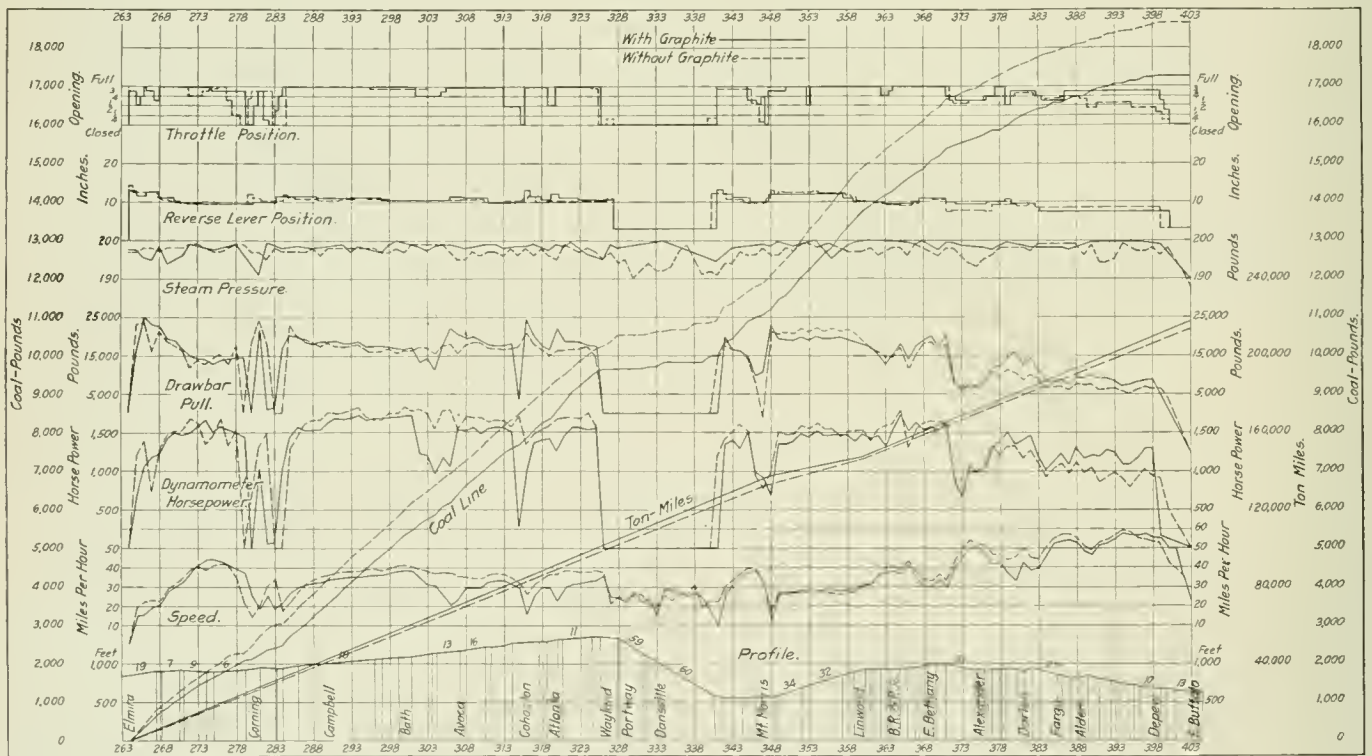

Comparison of Average Results of West-Bound Trips with and without Graphite Lubrication

materially. It is safe to assume that no locomotive is entirely free from loss of the second class and this may be so large as seriously to affect the operation of the locomotive. Constant endeavor is required to keep them to a minimum.

Lubrication is, primarily, an effort to reduce friction by interposing between the moving surfaces a film of oil, grease or other material of like character, which shall keep them from actual mechanical contact. The friction of lubricated surfaces between which this film is continuous, will follow approximately the laws of fluid friction, which is dependent to some extent upon the degree of roughness of the surfaces. In other words, the smoother the moving surfaces, all other

being figured at seven pounds of water per pound of coal, was 1,736.9 lb. a day, 26.05 tons a month and 312.14 tons a year. An investigation made by the writer some time since on a slide-valve engine showed that the valve leakage was reduced 51 per cent by the use of graphite for a period of about 10 days.

Graphite in flake form has been administered to locomotive cylinders and valves for many years, as the besmeared ends of relief valves bear ample witness. The usual method, however, in which the material was introduced in a single large quantity, is not ideal as much of it will be lost out of the exhaust without ever reaching the wearing surfaces. Ob-



viously the proper way is to feed very small quantities continuously just as oil is fed by the hydrostatic lubricator. About four years ago a lubricator for thus feeding graphite was developed and applied to a Lackawanna switching locomotive. This machine operates by means of an abrasive wheel oscillated by mechanical connection with some part of the valve motion of the locomotive, on which bears a stick composed of graphite in the flake form held together by a small amount of vegetable binder. The movement of this wheel grinds off small particles of the graphite stick which are carried directly into the steam chest and thence to the cylinder. The sticks are 1 in. in diameter and 1 in. long and it has been found that one stick per cylinder is an ample supply for a run of 100 miles; the magazine of the lubricator, however, holds four sticks which insures its not being necessary to put graphite in the lubricator on the road.

The general results obtained from the use of this lubricator were satisfactory and as it was recognized that it should have some advantageous effect on the general operation of the locomotive, it was determined to ascertain quantitatively just what this effect was. With this in view a series of road tests was conducted.

The locomotive was a Pacific type with 25-in. x 28-in. cylinders, in manifest freight service over a division 140 miles long, the profile of which is shown on the dynamometer chart. Tests were first made without the use of graphite; lubricators of the form briefly described above were then applied, and a duplicate series of tests run, all conditions with the exception of the use of graphite being kept as nearly constant as possible throughout both series. Westinghouse dynamometer car No. 2 was used to measure the work done at the drawbar and care was taken throughout to secure the highest degree of accuracy possible in a road test.

COMPARATIVE PERFORMANCE OF ENGINE 1165 WITH AND WITHOUT GRAPHITE CYLINDER LUBRICATION

Number of round trips	2	4
Distance run, miles	560	1,120
Total time	20 hr. 17 min.	39 hr. 38 min.
Running time	18 hr. 37 min.	35 hr. 43 min.
Duration of test (throttle open)	14 hr. 48 min.	28 hr. 4 min.
Number of stops	17	33
Temperature of air, total	66.9	70.2
Diameter of exhaust nozzle, in.	6 9/16	6 9/16
Speed, average m. p. h.	30.2	32.6
Boiler pressure, average, lb.	196.3	196.9
Coal, as fired, total, lb.	66,337.5	141,864.6
Coal, dry, total, lb.	64,526.7	137,900.5
Dry coal fired per hr., lb.	4,359.9	4,912.6
Dry coal per hr. per sq. ft. grate area	75.17	84.7
Water delivered to boiler, total, lb.	504,477.6	1,014,909.9
Water delivered to boiler per hr., lb.	34,086.3	36,151.1
Equivalent evaporation from and at 212 deg., lb. per hr.	42,340.1	44,858.8
Equivalent evaporation from and at 212 deg., lb. per hr. per sq. ft. heating surface	10.07	10.67
Equivalent evaporation from and at 212 deg., lb. per hr. per lb. dry fuel	9.70	9.13
Boiler hp.	1,227.3	1,300.2
Efficiency of boiler	67.8	63.9
Gross tons, total	6,339	12,478.5
Gross ton miles, total	887,460	1,746,990
Dry coal per 1,000 ton miles	72.71	78.94
Number of cars, total	219	420
Car miles, total	30,560	58,800
Dry coal per car mile	2.11	2.35
Drawbar pull, average, lb.	15,372	14,619.4
Drawbar hp., average	1,240.6	1,266.4
Million ft.-lb. work per hr.	2,460.8	2,511.4
Dry coal per drawbar-hp.-hr., lb.	3.53	3.89
Water per drawbar-hp.-hr., lb.	27.49	28.55

By referring to the summary of the test results it will be seen that the dry coal performance per 1000 ton-miles was 7.88 per cent less when graphite was used than without it. This checks very closely with the average of several other weighed fuel tests, in which a saving of from 7 per cent to 13 per cent has been made. On the drawbar-horsepower-hour basis 10.2 per cent less coal was burned when graphite was used, this latter unit being the most equitable for comparative use, where obtainable.

It will be noted that with graphite the average speed, on account of operating conditions, was somewhat lower than without but that the average drawbar pull was higher, the total work done being very nearly equal. The fuel rate with graphite was very considerably reduced, resulting in an in-

crease in boiler efficiency and equivalent evaporation. This can be attributed to the more effective working of the locomotive, as will be noticed later. The water rate shows an improvement of 3.71 per cent, and this, combined with the more efficient boiler operation mentioned above will account for the over-all advantage attributed to the use of graphite.

The small diagram illustrates one of the most interesting points in the whole discussion. It represents the drawbar pull lines of the locomotive as registered by the dynamometer

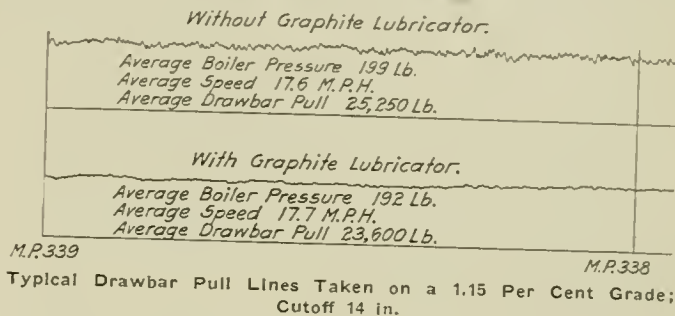

eter over the same length of track and under very nearly the same conditions except that graphite was used in one case and not used in the other. The reduced fluctuations show very clearly that the turning action of the wheel at the rail was considerably more uniform in one case than the other, and this can only be accounted for by the assumption that the jerky action of the valve was eliminated by the use of graphite, allowing the valve gear positively to control the workings of the valve and thus improving the steam distribution to the cylinders. The smooth and positive action of the valve gear with graphite has been apparent before this particular test was made, these results only confirming previous observations. It is believed that this is one of the reasons why an improvement was shown in fuel consumption, the engine developing the same power at a somewhat shorter cut-off on account of better steam distribution.

Like anything else, the application of graphite to the valve chambers and cylinders can be overdone, its introduction in too large amounts causing trouble from stuck rings and blocked ports. But if it is applied "homeopathically" instead of "allopathically," it results in a material improvement in the general performance of the locomotive. It is of special value with locomotives using highly superheated steam because of its refractory nature; it saves water and coal; it reduces packing ring, rod packing and bushing wear, and it makes the valve motion easier to handle.

## INCANDESCENT HEADLIGHTS AND HEADLIGHT LAWS

There is little doubt in the minds of the majority of railroad officers that the incandescent electric headlight is far superior in every way to the arc headlight, but in many cases they are a little dubious about adopting the former type in the face of the chaotic condition of the various state headlight laws, which in most cases specify that a headlight shall be used with a light source having an intensity of not less than 1,500 candlepower, measured without the aid of a reflector. Under such conditions they feel that the only headlight which will meet these requirements is one having an electric arc for a light source. In this connection it is interesting to note that the master mechanics' test at Columbus brought out the fact that none of the arc lights which were tested showed an unaided candle power of over 1,000. The strongest arc gave about 894 candle power without a reflector. Taking a specific case, arc-lamp headlight number 19 with an apparent beam candle power of between 55,000 and 60,000 had a lamp which gave 941.88 candle power without the

aid of a reflector, whereas incandescent lamp headlight number 13½ required only a 90.2 candle power lamp to give 55,000 apparent beam candle power; it seems, therefore, that there is not one arc lamp used in headlight service today that will meet the 1,500 candle power requirement of several of the state laws. Another fact brought out in the report of this test, which shows that the arc headlight is unsuitable for railroad service, was that a headlight with a beam candle power of over 50,000 develops about 30 per cent phantom lights. That is, a red and green signal would show white, and in addition it was shown that with an opposing arc light about 39 per cent of the red flag signals ahead of the engine, on which the observers were located, were obliterated or missed.

Another serious inherent fault of the arc lamp, when used as a headlight, is that its light is extremely rich in blue rays and consequently this type of lamp produces a large amount of light which is of no value whatever in enabling the engineer to identify an object on the track. For this reason a tungsten filament incandescent lamp, which gives a white light, is from eight to ten times as efficient as an arc lamp of equal current consumption as regards the distance at which a certain object can be picked up on the track by the headlight.

If the motive behind the legislation in the different states affecting the headlights were to be analyzed it would be found without a doubt that the object was not so much to secure a headlight with a high candle power source as to secure a headlight which was better and more reliable and satisfactory than those which were in general use at that time. It was simply a case of using an unfortunate definition, not realizing that the candle power of the lamp used in a headlight plays very little part in the final results, the size and shape of the reflector and of the light source, the condition of the reflecting surface and the quality of the light being, in many cases, more important than the candle power of the lamp itself.

Considering the fact that the arc headlight not only does not meet the requirements of the 1,500 candle power laws, but in addition is objectionable and dangerous because of the blinding and phantom light effect of its high intensity, unsteady and concentrated beam and because of its high maintenance cost and its unreliability due to the complicated arc lamp mechanism, it seems that its continued use in locomotive headlights is unwarranted when a much more satisfactory substitute is at hand.

Incandescent headlights of various makes and voltages are on the market and both the 6-volt and 32-volt sizes have proved reliable and efficient from all viewpoints, including those of track illumination and energy consumption.—*Railway Electrical Engineer*.

**ABUSE OF HIGH-SPEED DRILLS.**—Nothing will crack a high-speed drill more quickly than to turn a stream of cold lubricant on it after it has become heated by drilling. It is equally bad to plunge it into cold water after the point has been heated by grinding. Either of these practices is certain to impair the strength of the drill by starting a number of small cracks.—*The Engineer*.

**PULVERIZED PEAT FOR SWEDISH LOCOMOTIVES.**—Experiments in the use of peat powder or pulverized peat on locomotives of the Swedish state railways have demonstrated that locomotives using this fuel can haul as heavy trains and make as good speed as locomotives using anthracite coal. The railway directors have decided to undertake the development of this kind of fuel. Two methods will be followed. Two experts have been requested to give complete estimates of the cost of preparing a certain bog and the running expenses with the respective methods. The bog selected is said to have an area of about 500 acres.

## COAL COUNTER FOR USE IN LOCOMOTIVE TESTS

BY HUGH G. BOUTELL

On the drawing is shown a simple device which is designed to provide a ready means of automatically recording the number of scoops of coal fired on a locomotive equipped with an air-operated fire door. In making road tests, where the coal is not actually weighed it is the usual practice to place an observer in the cab to record on a tally sheet the number of shovelfuls of coal fired during the trip. Where a dynamometer car is used each shovelful may be recorded directly on a counter in the car by means of a push button and an electric circuit from the cab to the car. Neither of these methods is entirely satisfactory, however, because it requires an extra man in the cab. It is also quite likely that his attention may be diverted from time to time, when he will lose count of a few scoops of coal.

The simple device illustrated registers every time the fire door is opened and with a good fireman this is practically equivalent to registering the number of scoops of coal fired. The cylinder is turned out of brass and accurately finished to a diameter of 2 in. on the inside. In this cylinder is a simple brass piston 1¾ in. long, working easily in the cylinder

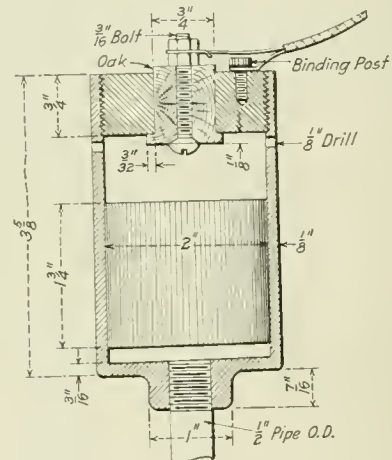

Electro-Pneumatic Counter for Use with Pneumatic Fire Doors

bore. The lower end of the cylinder is turned with a boss, into which is screwed an air pipe leading to the fire door cylinder. The upper end of the counter cylinder is threaded and into it is screwed a 2-in. plug about ¾ in. long. A ¼-in. hole is drilled out in the center of the plug, into which is driven a piece of oak, turned with a small shoulder on one end to keep it from working up in the plug. The oak piece is drilled for a 3/16-in. bolt, which passes up through the wood, the head projecting into the cylinder. This forms one terminal of an electric circuit and the other is formed by a small machine screw in the pipe plug. To these terminals are attached the wires connecting with the counter and battery in the dynamometer car. At the top of cylinder, just below the plug, are drilled four 1/8-in. holes to allow any air that may pass the piston to escape.

When air is admitted to the fire door cylinder it also fills the small counter cylinder, thus causing the piston to rise, completing the circuit and registering on the counter. When the air is discharged the piston will fall of its own weight.

The piston may be oiled occasionally, but too much oil should not be used.

**MOMENT OF FRICTION.**—Frictional resistance of a bearing is the resisting torque, or so-called moment of friction, or it may be defined as the quotient of the resisting torque by the mean radius of the journal.—*Power*.

# NORFOLK & WESTERN ELECTRIFICATION

## Some of the Results with Single-Phase Equipment; Locomotive Inspection and Repair Facilities

The electrified section of the Norfolk & Western is located in the southern part of West Virginia in the Pocahontas coal district and extends from Bluefield to East Vivian, a distance of about 30 miles. There is a total of about 100 miles of single track in the electrified zone, including the double track main line and the numerous side spurs.

The 3,100-ft. Elkhorn tunnel is the only part of the electrified section not double tracked. The line between Bluefield and East Vivian, which winds around a narrow steep-sided valley, is very crooked, about 60 per cent of the entire division being curved, with a maximum curve on the main line of 12 deg. The grades are also numerous and heavy, the four-mile approach to the Elkhorn tunnel from the west being 2 per cent and the one-mile approach from the east being 2.36 per cent.

The main traffic, which consists of loaded coal cars, is eastbound. The westbound traffic is for the most part, empties which are distributed to the various mines on the west slope. Considering the roadbed conditions outlined

veloped a much higher drawbar pull than was guaranteed by the builders. They consist of two units, each of the 2-4-2 type and weighing 135 tons, the total weight being 270 tons. The tables show their principal dimensions and performances.

Length overall	105 ft.	8 in.
Driving wheel base, total	83 ft.	10 in.
Rigid wheel base	11 ft.	0 in.
Truck wheel base	16 ft.	6 in.
Height, rail to pantagraph (locked)	16 ft.	0 in.
Height, rail to top of cab (maximum)	14 ft.	9 in.
Width overall (maximum)	11 ft.	6 1/4 in.
Width over cab body	10 ft.	3 in.
Diameter of driving wheels		62 in.
Diameter of truck wheels		30 in.
Weight on drivers	220 tons	
Total weight of locomotive	270 tons	

	Train on 1.5 and 2 per cent grade	Train on 1 per cent grade	Train on 0.4 per cent grade
Weight of trains, tons	3,250	3,250	3,250
Locomotives per train	2	1	1
Approximate speed, miles per hour	14	14	28
Drawbar pull per locomotive, pounds:			
Uniform acceleration	91,800	114,000	79,400

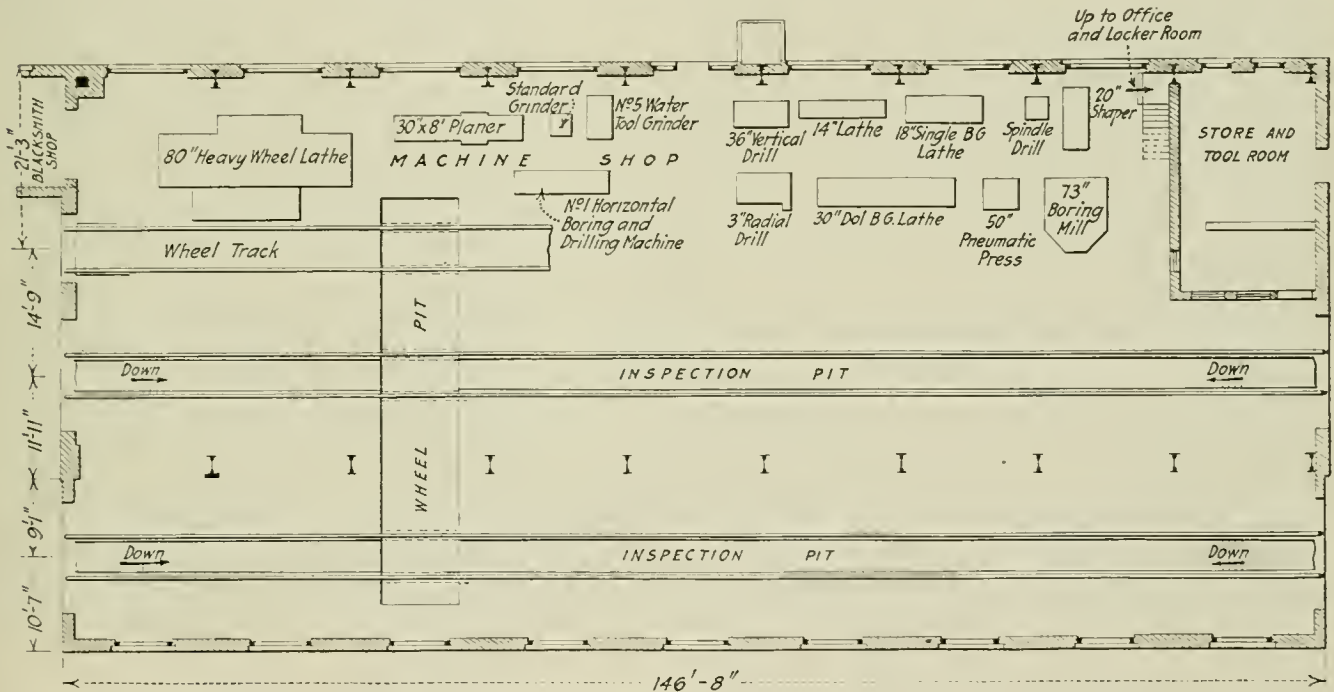

Plan of Locomotive Inspection Building at Bluestone, Showing Location of Inspection Pits and Machine Tools

above, together with the fact that the average eastbound traffic, at the present time, is about 35,000 tons per day, with 3,250 tons per train, it is easy to understand why the high voltage overhead trolley system was chosen. The system finally installed is known as the single-phase, 11,000-volt trolley system, which consists of an 11,000-volt catenary-suspended trolley, from which current is collected by a bow pantagraph on the locomotive. A transformer carried in the locomotive cab transforms the voltage from 11,000 to 750 and a phase converter, operating at the latter voltage, furnishes three-phase current to the wound-rotor induction motors, of which there are eight on each locomotive. The system operates at 25 cycles. The motors are wound for two synchronous speeds, 14 and 28 miles per hour, and are started by inserting water rheostats in series with the rotor windings.

The 12 locomotives, which are now in service, have de-

At speed on 2 per cent grade	75,400		
At speed on 1 per cent grade		85,800	
At speed on 4 per cent grade			4,600
Maximum guaranteed accelerating tractive effort per locomotive	133,000	133,000	90,000
Approximate maximum guaranteed hp. developed by motors	5,000	5,000	6,700

The traction powerhouse is located in Bluestone, about 14 miles west of Bluefield. Single-phase power is obtained from three-phase turbo-generators, which have a single-phase rating of 10,000 kw. at 80 per cent power factor. The current, after being stepped up to 44,000 volts, is transmitted to the various substations, where it is again stepped down to the trolley pressure of 11,000 volts.

### OPERATION

Early in 1914 the average number of trains hauled by steam engines in both directions over the section under consideration was nine, each train weighing about 2,900 tons. This is equivalent to 26,100 tons per 24-hour day. Each

train was hauled by from two to three Mallet compound locomotives, depending on the grade, and a total of 20 such engines were required for this service.

The use of electric locomotives has had a marked effect on the operation of trains through the Elkhorn tunnel. The dispatcher will now allow a full tonnage train to leave Eckman Yards, eastbound, ten minutes before a local passenger train is due, and will allow the same train to enter the tunnel four or five minutes ahead of a passenger train, as he is perfectly sure that it will come through without delay. Formerly, 20 minutes was the time figured on for a train with three Mallet engines through the tunnel, not only because its speed was less, but also because of frequent stalling. Two electric locomotives consistently pull 3,250-ton trains through the tunnel in about three minutes.

It will be of interest to follow an electric locomotive on one of its regular round trips over the line from Bluefield to East Vivian or Eckman and back. (The main yards at the west end of the line are at Eckman.) Leaving Bluefield inspection track, the locomotive goes to the West Bluefield Yards, picks up a train of from 85 to 95 empties, and proceeding westward, sets them off at the various mines in the coal field west of the tunnel. Proceeding to Eckman, the locomotive, without turning, picks up what is known as a tonnage train of 3,250 tons, consisting of from 28 to 45

The train (westbound) consisted of one electric locomotive with a trailing load of 92 empties. When going up a 1.4 per cent grade west of Bluestone at 14 m. p. h. the ammeter showed 500 amperes, and when coasting down the two per cent grade through and west of the Elkhorn tunnel an average regenerative current of 300 amperes was registered. Later, when coming east with 23 75-ton cars (over half a normal tonnage train) with one locomotive, the ammeter showed 550 amperes on the two per cent up grade and a regenerative current of 400 amperes on the 2.36 per cent down grade. One locomotive will take a full tonnage train of 3,250 tons down the 2.36 per cent grade at about 15 m. p. h. without air brakes. Under such conditions, which are normal, the regenerative current per truck is about 550 amperes. The regenerative ability of the three-phase motor

N. & W. ELECT'N.		
NOS. OF CABS—ELEC. LOCOS.		
.m. — 191		
LOCO. NO.	EAST CAB.	WEST CAB.
2500	E.....	E.....
2501	E.....	E.....
2502	E.....	E.....
2503	E.....	E.....
2504	E.....	E.....
2505	E.....	E.....
2506	E.....	E.....
2507	E.....	E.....
2508	E.....	E.....
2509	E.....	E.....
2510	E.....	E.....
2511	E.....	E.....

*Gen'l Foreman Elect'n.*

Form Used to Keep Record of Cab Numbers

cars, depending on their capacity, and starts east. A pusher is used from Eckman to Ruth (at the eastern portal of the Elkhorn tunnel and at the summit of the two per cent grade). The single locomotive then takes the train to Flat Top Yards, where additional tonnage up to 4,750 is accepted. The run from Flat Top to Bluefield is made with the help of a pusher, on the three-mile, 1¼ per cent grade at the end of the division, between Graham and Bluefield.

The round trip from Bluefield to Eckman and back is made in the average time of seven hours, and two such trips constitute an average day's work for one train crew. Formerly, with steam operation, a day's work for one train crew consisted of a single round trip between Bluefield and the coal field, which usually took 12 hours. There are usually 9 of the 12 electric locomotives actually on the road, with one at Bluestone undergoing general repairs, one idle at Bluestone for relay and one over the inspection pit at Bluefield.

Some ammeter readings taken on one of these trips may be of interest. These readings were taken from the four ammeters in the cab, each meter registering the current taken by each of the four trucks. Normally the current taken by the different trucks is equal; therefore, the total current taken by the locomotive is four times the reading of one ammeter.

Form M. P. 392-E.

**Norfolk & Western Railway Company**  
INSPECTION CARD  
**ELECTRIC LOCOMOTIVES.**

LOCOMOTIVE NO. \_\_\_\_\_ CAB NO. \_\_\_\_\_

ITEM	NAME
1	PANTAGRAPH & GROUND SWITCHES
2	BELL & CORD
3	HEADLIGHTS
4	ROOF WIRING.
5	OIL CIRCUIT BREAKER
6	MAIN TRANSFORMER
7	PHASE CONVERTER.
8	PHASE CONVERTER AIR GAP, BOTTOM
9	STARTING MOTOR.
10	COMPRESSOR.
11	FAN
12	MAIN KNIFE SWITCH
13	SWITCH GROUPS.
14	REVERSERS.
15	POLE CHANGEOVER SWITCHES.
16	CONTROL CHANGEOVER SWITCHES.
17	RHEOSTATS.
18	MAIN MOTORS.
19	MAIN MOTOR AIR GAP, BOTT. 1 2 3 4
20	MAIN MOTOR AIR GAP, SIDES. 1 2 3 4
21	MAIN MOTORS BLOWN OUT.
22	GEARS & PINIONS.
23	MOTOR-GENERATOR
24	RELAYS.
25	METERS.
26	COMPENSATORS.
27	CONTROL & LIGHTING TRANSFORMER.
28	LIGHTING CIRCUITS
29	REACTANCE COIL.
30	WIRING.
31	MASTER CONTROLLER.
32	AUXILIARY CONTROLLER.
33	BATTERIES
34	HEATERS.
35	FLANGE OILER.
36	HAND PUMPS.
37	WATER PUMPS.
38	SANDERS.
39	AIR BRAKES.
40	CONTROL AIR SYSTEM
41	CAB.
42	CAB BLOWN OUT.
43	TRUCKS.
44	DRAFT GEAR.
45	JACK SHAFTS.
46	JACK SHAFT OIL CUPS.
47	T.L. JUMPER.
48	OIL & GREASE.
49	TOOLS & EQUIPMENT.
50	
51	

191

Inspection Card Used in Connection with the General Inspection of Electric Locomotives at Bluestone

is one of the main factors which makes their use for this severe service particularly successful. Another characteristic of the three-phase motor which has proved most valuable is its inherent ruggedness, due to the absence of a commutator.

When starting a heavy train on a grade with a steam locomotive the pusher does not shut off steam when the head engine stops the train with the air brakes. It simply holds against the train with open throttle and in so doing permits the head engine to release the air and pick up its share of the slack when ready to start. When the front half of the train is under way the pusher will start its half and the entire train will move with a minimum of jarring and bumping. Of course, poor track and weather conditions may complicate matters to such an extent that perhaps three or four minutes might be required to start.

The three-phase motors on the electric locomotives are peculiarly adapted to stand up under the severe conditions above mentioned when starting a heavy train. In fact, their ability to stand still under full load for a maximum of five minutes, while holding a train about to be started on a heavy grade, contributes in a large measure to their success in this installation.

LOCOMOTIVE MAINTENANCE

The facilities provided for the inspection and maintenance of the electric locomotives appear small when compared with the extensive and elaborate facilities required for the proper maintenance of an equal power in steam locomotives. One rather small machine and inspection shop at Bluestone and one small frame office and store building, an open air inspection pit and six sand boxes, at Bluefield, are all the electric locomotive facilities provided. The absence of round-houses, coal docks, cinder pits and water tanks is particularly noticeable. The general inspections and heavier repairs are made in Bluestone, a point about 11.5 miles west of Bluefield, while the terminal inspections and light running re-

pairs are made at Bluefield, the eastern terminus of the electric zone.

a narrow gage track for the transfer of wheels between the locomotives and the wheel track, as they rest on a wheeled pneumatic jack.

The pit furthest from the machine bay is used almost exclusively for inspection purposes, and to facilitate this inspection a platform, 112 ft. long, and located 12 ft. 8 in. above the rails, has been erected near it.

All erection and repair work is done over the other inspection pit and in the machine bay. This part of the shop is served by a 30-ton Whiting crane equipped with a 30-ton main hoist and a 5-ton auxiliary hoist. Some of the machine tools installed in the machine shop are individually motor-driven and part are arranged for group drive from one motor-driven line shaft. All motors are 220-volt, direct current. The machine tools installed are:

Description of tool.	MOTOR DRIVEN	
	Hp.	Motor R.P.M.
80-in. driving wheel lathe.....	50	500-1,000
73-in. boring and turning mill.....	2	1,200
30-in. x 30-in. x 8-ft. planer.....	12	375-1,500
	5	1,100



Power House and Locomotive Inspection Building at Bluestone

When considering the question of providing proper maintenance facilities for the entire installation, it was decided that Bluestone was the logical site for the main locomotive inspection and maintenance building, because of its central location as regards the electric zone, and because the power plant was to be located there, near the only available water supply.

The locomotive inspection building at Bluestone is a substantial brick and steel structure 148 ft. by 68 ft., similar in style to the power plant. This building is shown on the right of the power house in one of the illustrations. By referring to the floor plan it will be noted there are two inspection pits running the full length of the building, with a wheel pit connecting them with the wheel track in the machine tool bay. The inspection pits are of concrete, are well drained and are provided with numerous lighting, power and compressed air outlets. The wheel pit is equipped with

36-in. x 15-ft. engine lathe.....	12.5	400-1,600
60-in. x 6-ft. boring and drilling machine (hor.).....	4	500-750-1,500
20-in. crank shaper.....	4	500-750-1,500
3-ft. radial drill.....	3	1,000

BELT DRIVEN GROUP

18-in. x 10-ft. engine lathe.....	15	825
36-in. vertical drill.....		
14-in., 2 spindle, sensitive drill.....		
36-in. x 4-in. wet tool emery wheel.....		
Size c, Diamond double emery grinder.....		

LARGE PNEUMATIC TOOLS

600-lb. single frame hammer
45-ton rod bushing press
Wheel jack

In addition to the above a winch driven by a 15-hp., 1,650-r. p. m. motor is located just outside of the western end of the shop for moving the locomotives which are being inspected or repaired.

The overhead system of electric lighting is employed, with large tungsten lamps in enamelled metal reflectors located on the steel roof trusses. A special feature of the lighting system is the use of 100 and 60-watt lamps in angle reflectors, which are mounted on the side walls, about 10 ft. from

the floor. Extension cord receptacles are provided where necessary.

#### LOCOMOTIVE INSPECTION

The general inspection routine requires under normal conditions that one locomotive be sent to the shop each day. Rotating the 12 locomotives in this way insures that each one receives a general inspection every 12 days. Of course, extra heavy repairs upset this plan, but as a general thing it is closely followed. Immediately after a locomotive arrives in the shop it is given an inspection card, as illustrated. As will be noted, this card gives a complete list of the locomotive parts to be inspected. Each man in the inspection force is permanently assigned to cover a certain number of these items, the total being divided between seven wiremen, one airbrake man, one machinist and one pipefitter. In this

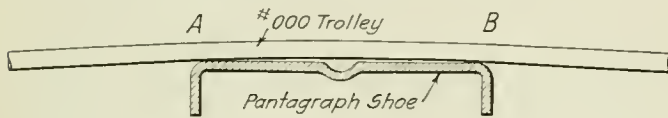

Sketch Showing How the Upward Thrust of the Pantograph Shoe Curves the Trolley Wire So That It Makes Contact with the Shoe at Points A and B Only, Thus Causing Greatest Wear at Those Points

way the work for each man is automatically outlined in advance and no time is wasted giving routine instructions. When the card is hung on the locomotive the force of inspectors start to work and as the inspection of each item is completed the man responsible marks his initials after it in the column headed "Name." Any fault found is immediately reported to the foreman inspector, who takes steps to have it corrected.

As each electric locomotive is made up of two distinct units or halves, it is possible to take one-half of one locomotive and attach it to a half of another locomotive. In other words, these units or halves are interchangeable. This arrangement has proved most convenient, because it often happens that two locomotives require repairs to only one of these units at the same time. By the simple expedient of coupling the two good halves together, one good locomotive is made from two which would otherwise be unfit for serv-



Locomotive Inspection Facilities at Bluefield; a Pit, Which Cannot be Seen is Located in the Second Track in Front of the Frame Building

ice. Such a practice necessarily requires some special system for keeping the locomotive numbers straight. The system used is to give permanent distinctive numbers to the cabs (as the units are called) and temporary numbers to the entire locomotive of two cabs. The cab numbers are on a brass plate riveted to each end of the cab on the inside and consist of the letter E and a number. The locomotive numbers are on removable plates hung on the outside of each cab. A record showing the cab numbers assigned to each locomotive number is kept and each time a change is made copies of the corrected list are sent to the officers interested.

The maintenance facilities at Bluefield, where terminal inspections and light running repairs only are made, consist

of a small frame building containing an office, an oil room, a locker and wash room and a store room. An open air inspection pit and six elevated sand boxes are also provided. The day inspection and maintenance force at Bluefield consists of an inspector, a clerk, a wireman, a machinist, a pipefitter, an oiler and three laborers. The night force consists of a machinist, a pipefitter, and oiler and two laborers. Except for the electric light wiring, no inspection is made of the electric apparatus at night. The locomotives are expected to be ready for service after a layover of 40 minutes at Bluefield, except in cases requiring extraordinary repairs. This means that a locomotive is idle for inspection only about two hours out of every 24, or about 8 per cent of the time.

#### LOCOMOTIVE PERFORMANCE

In general, it can be said that the locomotives have more than come up to expectations in their ability to stand up under the most severe traction conditions in the world, and considering the racking service and the fact that these are the first locomotives built to haul such enormous trains over heavy grades, their performance has been remarkable. No tires have been replaced since electric operation was inaugurated in May, 1915. Any flat spots that have appeared have been filled up by electric welding and then ground off to the proper contour.

The solution in the water rheostats (water and soda ash) is renewed about once a week. The renewable steel pantograph shoes have a serviceable life of from two to three months, the greatest wear taking place along the edges of the shoe. This is evidently because its contact surface is flat, whereas the trolley wire, at the point of contact, takes the form of a long radius arc due to the upward thrust of the pantograph. This condition is of course exaggerated in the sketch. It is usually found that while the shoe wears through along the edge, the metal near the center is hardly touched.

## SPONTANEOUS COMBUSTION OF COAL

BY J. F. SPRINGER

The Canadian Pacific maintains at Montreal a coal pile whose maximum capacity amounts to about 250,000 tons. This coal is a good quality of bituminous from the Sydney coal field on Cape Breton Island, Nova Scotia and is brought to Montreal by boat during the warm season. During the winter when river navigation is closed, the coal is mined and stored in piles at the mines. These piles give practically no trouble from spontaneous combustion, although the piles are quite deep. At Montreal, on the contrary, much trouble has been experienced from this source and yet the depth of storage is only about half that at the mines. The New York Edison Company maintains a big bituminous storage yard where the coal is piled up to heights of about 35 ft. Spontaneous combustion gives trouble here also. Indeed the subject is one of importance to all consumers who maintain bituminous piles from 20 to 40 ft. in depth.

As is generally known, spontaneous combustion is the ignition and burning of coal without the assistance of an outside source of high temperature either at the beginning or during the progress of the fire. The coal in the hold of a vessel will at times take fire and burn for days or weeks, not only without assistance but despite efforts to put out the fire. The fire will originate in the depths of the pile and spread from that point. The causes and prevention of spontaneous combustion are subjects which have engaged serious attention for a number of years and considerable information of value is now available. Spontaneous combustion, like ordinary combustion, requires two things: a temperature high enough to cause ignition and a supply of oxygen. But it should be noted that it is only necessary that a small part of the pile

be at the temperature of combustion to start the fire. Once it is started, of course, the high temperature spreads.

Various suggestions have been made as to air movements through a coal pile. A report of two or three somewhat casual inspections of a large pile ventilated with a number of vertical holes passing from top to bottom states that they failed to indicate a down draught; warm air appeared to rise from all the holes, and in winter when the pile was covered with snow, melted passages through to the surface. Coal stored on wet, impervious soil is more apt to suffer from spontaneous combustion than coal stored on dry sand or on a thick bed of cinders. It is not clear, however, that this must be explained on the basis of the want of circulation in the one case and its existence in the other.

The oxygen to support the combustion, however, does not appear to come directly from the air above and around the coal pile. The action which takes place will be understood from the following considerations. It is estimated that of the 42 or 43 cu. ft. occupied by one ton of steam coal 12 cu. ft. are filled with air. This is too small a quantity by itself to effect more than an insignificant amount of combustion. But steam coal is said to be capable of absorbing double its own volume of oxygen in the space of 10 days. Using this as a basis, one investigator calculates that the 30 cu. ft. of actual coal in a ton absorbs 60 cu. ft. of oxygen in 10 days. This is the amount of oxygen in 300 cu. ft. of fill air. Consequently, to secure this amount of oxygen necessitates 25 changes of air in 10 days. This indicates a slow circulation, a complete change of air taking place in about 9 1-2 hours. This estimate cannot be applied to all coals or all conditions of the same coal, but it seems probable that a circulation of air really takes place, and that this circulation is a fundamental factor to be considered in dealing with spontaneous combustion.

Another important fact is that the temperature of the coal rises continuously as the absorption of oxygen goes on. The results of an investigation made at a British colliery clearly indicate the truth of this statement. At the shaft bottom the temperature of the air of the intake airway was 60 deg. F.; at the return airway, it was 17 deg. higher. Some of this rise was doubtless due to the higher temperature of the strata passed over by the air in its course through the mine. But as the temperature of the strata at the bottom of the pit was only 68 deg., there remains a considerable rise unaccounted for by the mere depth below the surface. A certain amount of heat was supplied by living bodies, candles, settling of strata overhead and friction. But these were estimated to total no more than 20 per cent of the observed increase. It would seem then that we have here a case of heat being supplied by the oxidation of exposed coal in the mine passages. In fact, the body of coal behind the exposed surfaces was itself being heated. In the course of about four years the coal 10 ft. back gained from 17 to 24 deg. in temperature.

That oxygen was being lost from the air was indicated by analyses of air taken at various points in its passage through the mine. The average loss of oxygen was found to be something over three times the gain of carbon dioxide, an excessive ratio. Further, some of this coal in a powdered condition was put into a flask which was then sealed. A gage was arranged to determine the pressure of the air in the flask. At once, the tension began to diminish. It continued to diminish for nine days, when it became practically stationary. After six months an analysis of the air within the flask showed that the oxygen had disappeared; nitrogen forming about 98 per cent of the remaining gas. No doubt, this coal is somewhat exceptional so far as the amount and rate of absorption are concerned, but the fact that bituminous coal absorbs oxygen and that this absorption is accompanied by the evolution of heat, is of general application.

Another fact which seems well founded is that the rate of

absorption of oxygen increases with the rise in temperature. Thus in the case of the British coal already mentioned it was determined that the rate was just about doubled for every rise of 30 deg. F. in temperature. As absorption of oxygen becomes more rapid, the evolution of heat must take place with greater rapidity and we have the conditions for a constant acceleration of the increase in temperature. A coal pile is a poor conductor of heat. Whatever heat it loses is carried off by the air circulation, which, as has been pointed out, is comparatively slow. In view of these facts it is not difficult to conceive of a temperature being reached in the heart of a large, deep pile, high enough to cause ignition. There being oxygen at hand, the requirements for combustion are met and a fire starts.

A French investigator some years ago constructed a pile of slack coal 130 ft. long and varying in height from zero to about 20 ft. At the top, the pile was about 3 ft. wide. Daily temperature readings were taken at several points along the pile, all of which were near the bottom, but the distance from the bottom increasing with the depth of the pile. The test covered a period of about three months. Except for the points near the low end of the pile, the temperature rose steadily, reaching a maximum at the end of the test. Through that part of the pile where the depth was about 13 ft. or less, the temperature never rose higher than about 160 deg. F. Beyond this height, the temperature continued to rise until the pile caught fire. Such atmospheric conditions as the temperature and dry or wet weather had no appreciable influence on the temperatures within the pile, except at the extreme low end.

From a general review of this subject certain American investigators have found nine factors which are generally considered of especial importance in their relation to spontaneous combustion. These are: The proportion of volatile matter; the purity; the presence or absence of sulphur compounds such as pyrites; the temperature of the coal; its size; the presence of occluded gases; the presence of moisture; the accessibility of oxygen; and the pressure on the coal.

Anthracite coals with their low volatile content are practically exempt from spontaneous combustion, while pure bituminous coals seem to be more subject to it than others of less purity. Opinions differ with respect to the part played by pyrites. It is well established that pyritic coals are liable to an increase of temperature due to oxidation of the pyrites. Coals containing little or no pyrites, however, ignite spontaneously.

From the preceding brief description of the process which results in the final ignition of coal in large piles it may be expected that the initial temperature of the coal will have a marked influence on the trouble experienced from this source. If the temperature is high when the coal is stored not only is the interval up to the ignition point reduced, but the initial activity of the oxidation process is increased. We may have in this a partial explanation of why Cape Breton coal stored at Montreal in warm weather gives trouble while the same coal stored at the mines in cold weather gives no trouble. That the liability to spontaneous ignition is much increased either by a high initial temperature or by a rise in temperature due to the proximity of steam pipes and flues or even from the heat of the sun, is generally accepted. The danger point beyond which the liability is decidedly increased is usually placed at about 150 deg. F. An external source of moderate temperature may facilitate spontaneous combustion by causing the release of inflammable gases which are occluded in the coal.

That heated coal is dangerous coal, even though the temperature be well below the ignition point is brought out clearly by the following experiment tried in an investigation of spontaneous combustion. A pile of coal containing about two tons was arranged in the form of a cone. A ditch around the base, filled with water, provided a seal for a cover which completely

enveloped the pile. The coal was heated to a temperature of about 212 deg., F. A number of holes in the cover were left open and in the course of two days the pile set itself on fire. The spontaneous combustion thus produced was stopped by simply closing the holes. By this means the temperature was reduced to 140 deg. In fact, the temperature could be made to rise or fall simply by opening or closing the holes in the cover.

Oxidation of hydrogen and carbon at rather low temperature (from 250 deg., F. up) is dangerous largely because of the amount of heat liberated. This leads to the next step, the autogenous oxidation of the coal which is independent of external heat for its maintenance. The temperatures of this stage range from about 390 deg. F. to over 500 deg., and it leads to ultimate ignition. The ignition temperature varies for different coals, usually falling somewhere between 700 and 900 deg. F.

There is a general agreement that the finer the coal the more rapid the oxidation, which in effect means the greater the liability of spontaneous combustion. The reason is probably to be found in the greater total surface presented to the action of the oxygen in fine coal as compared with lump. Even the fine coal resulting from handling may be productive of danger since it accumulates near the bottom of the pile, a situation favorable to the accumulation of heat. Friable coals appear to be especially subject to spontaneous combustion.

The danger from occluded gases seems to be due to their release and oxidation, the heat thereby liberated raising the temperature and promoting conditions favorable to self-firing.

As to the part played by the presence of moisture there is a great difference of opinion. One authority claims that weather conditions have but little to do with spontaneous combustion. Another claims that spontaneous firing arises from the action of ozone formed "by the action of the sun on warm, sunny days following a rain, when the surface evaporation is especially great." The following statement is made as the result of an investigation of Illinois coal. "Any coal with conditions favorable to oxidation will be facilitated in that action by moisture. It is to be noted in this connection that the normal water content or vein moisture of coals in this region (Illinois) is rarely below 10 per cent and ranges usually from 12 per cent to 15 per cent. The presence of such water must be borne in mind in considering the likelihood of chemical activity on the part of the pyrites present. Without exception, in all the series of tests, the wetting of the coal increased the activity as shown by the ultimate temperature."

The accessibility of oxygen is undoubtedly a large and important factor in causing ultimate ignition. Precisely what the reaction of the oxygen is does not seem as yet to have been clearly established. One conception considers the oxygen as uniting directly with the hydrogen and the carbon in the coal; another considers that it combines with unsaturated humus bodies. What is clear, however, is the fact that the oxygen is absorbed and heat liberated.

Pressure as a contributory cause of spontaneous combustion seems to be favored by some investigators. In fact, it is generally conceded that deep piles are dangerous piles. Two storage plants were maintained by an Australian gas company, the depth of the pile in one being about 14 ft., while in the other it was 20 ft. No case of spontaneous combustion is reported in connection with the shallower pile. On the other hand, a great deal of care was required to prevent spontaneous combustion in the deeper pile, all other conditions except depth of pile being the same at both piles. The experience of the Chicago & Alton some years ago with three different piles of run-of-mine Springfield coal, point to the same conclusion. Two of the piles were each 6 ft. high, while the third was 10 ft. high. All three contained

a very considerable percentage of slack. The first two piles escaped firing, but the last caught in several places. Attention has also been directed to the fact that the third pile was a broad one, while the others were comparatively narrow. It is doubtful, however, whether the width had any influence in effecting the spontaneous combustion.

## WATER READINGS IN LOCOMOTIVE TESTS

BY TOWSON PRICE

In making locomotive tests in which the coal and water are measured, it is desirable to take frequent readings of the depth of water in the tank. This is usually done by having two small valves with nipples tapped into the tank at opposite corners to which glass tubes are connected by means of rubber tubing. The glass tubes are applied along scales attached to the sides of the tank and the readings taken from them are then averaged.

There are two disadvantages to this method. The readings to be accurate have to be taken when the engine is stopped and on nearly level track and in cold weather the water in the valve or tube is liable to freeze. The following method of determining the height of the water in the tank eliminates these disadvantages and has been used with success.

Instead of measuring the height of water in the tender directly, the equivalent of the water pressure on the bottom of the tender is transmitted to the dynamometer car by means

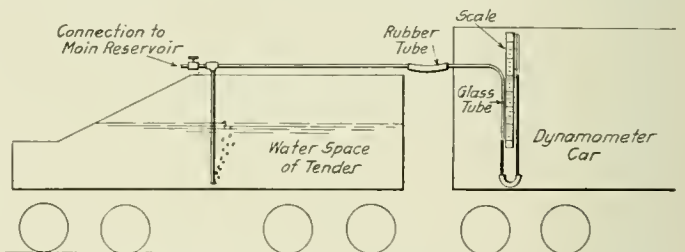

Method of Taking Tenders Water Level Readings in Dynamometer Car

of a flexible tube and the height of the water there shown by means of a glass U-tube and movable scale. The point at which the pressure is determined should be directly below the center of gravity of the average amount of water carried in the tank.

The arrangement of the air pipe and the U-tube connections are shown in the illustration. The valve connected to the air line is left open slightly so that the air will just bubble out of the bottom of the vertical pipe through the water in the tender. This creates a pressure in the horizontal pipe which is connected by a rubber tube to the glass U-tube in the dynamometer car. With the air just bubbling slowly into the water, the pressure in the U-tube, which is balanced by the column of water as shown, should be exactly equivalent to the water height in the tender if the vertical tube extends very close to the bottom of the tank. For the greatest accuracy the water in the U-tube should be at the same temperature as the water in the tender, but a slight variation in temperature makes very little difference in the accuracy.

**INCREASING VALVE TRAVEL.**—In engines having the valve moved by a rocker-arm that receives motion from the eccentric rod, the valve travel can be increased by reducing the radius of the eccentric rod rocker-arm or increasing the radius of the valve-rod rocker-arm.—*Power.*

**SIZE OF RETURN-TUBULAR BOILERS.**—The nominal horsepower size of horizontal return-tubular boilers of ordinary proportions, as commonly rated, can be roughly estimated by multiplying the square of the diameter in feet by the length in feet and dividing the product by five.—*Power.*



# CAR DEPARTMENT

## RATIO OF STRESS TO END LOAD FOR FREIGHT CAR CENTER SILLS

BY C. M. FARIS

The writer finds so many mistakes made by draftsmen in using the M. C. B. formula for finding the ratio of stress to end load, and misconceptions regarding the meaning and value of the term so common, that he believes a simple explanation of the principles of mechanics upon which the formula is based may prove of value to many of those who are called upon to apply it to problems of car design.

The expression, "the ratio of stress to end load," and the formula for its definition,  $\frac{I}{A} + \frac{X}{SM}$  (where  $A$  is the area in sq. in. of the cross section of the center sill,  $X$  the distance in in. from the neutral axis of the section to the center line of the resultant of the end load, and  $SM$  is the modulus of the section) were recommended by the committee on car construction of the Master Car Builders' Association in 1913, as a means of clearly defining the strength requirements of steel

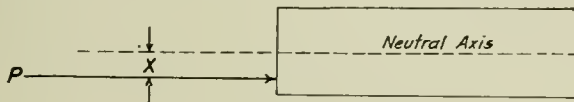

Fig. 1

center sills. The necessity of establishing a standard of minimum strength for steel center sills became evident in connection with the settlement for damages in interchange service soon after the introduction of steel underframes in car construction. Some designs of steel center sills were strong enough and no damage need be expected to occur to them in fair usage. The handling company, therefore, could justly be held responsible for any damages that might occur. On the other hand, some steel center sills were so faulty in design and so weak that it would be unjust to charge the handling company with their maintenance. This condition led to the recommendations of the committee, above referred to.

The principle involved in the action of buffing forces on center sills when considered as static loads applied at their ends, is essentially that of the column. With the load applied, not on the center line or neutral axis of the column, but to one side, as is usual with draft attachments to the center sills, we have the conditions of a column with an eccentric load. The committee provided for simple strut or column action by requiring that the members subject to end load be "anchored at intervals not exceeding  $20d$ ," where  $d$  is the depth of the member in inches measured in the direction in which buckling might take place. With the recommendation that the ratio of stress to end load should not exceed 0.06 for new cars, a standard of minimum strength of center sills to resist buffing loads has been established.

In considering the principles of mechanics involved, it should be noted that the conditions to be dealt with are those of a short column with an eccentric load, because the sills or members are required to be securely anchored at such regular intervals as will provide against the effects of long column action. In the expression, "ratio of stress to end load," the maximum allowable stress in pounds per square inch produced in the sill by the end load or buffing force, is referred to, and the term, end load, refers to the buffing

force in pounds, considered as a static load. If  $P$  is the end load and  $S$  is the stress, then the ratio of stress to end load is  $\frac{S}{P} = \frac{I}{A} + \frac{X}{SM}$ , from which  $S = \frac{P}{A} + \frac{PX}{SM}$ , which is the ordinary formula from mechanics for finding the stress produced in a short column by an eccentric load.

The stresses in a column under eccentric load may be considered as made up of two parts; one is the direct stress and is given by  $\frac{P}{A}$ , the other is the eccentric stress and is given by  $\frac{PX}{SM}$ .

The direct stress is compression uniformly distributed over the area of the cross section, while the eccentric, or bending stress, is a tension on one side and a compression on the other. The resulting combined stress then is the sum of the direct and the eccentric stresses on the compression side of the column and the difference between these stresses on the tension side.

For sills that have a symmetrical section, a mistake can hardly be made in using the formula. But for sills with an unsymmetrical section, which is a common condition for freight car center sills, there will be two sections moduli and mistakes are commonly and frequently made in using the wrong one. Let Fig. 1 represent an unsymmetrical center sill with the center line of the end load  $P$  applied at a distance  $X$ , below the line of the neutral axis. Let  $SM_t$  be the section modulus of the sill for the top of the section and  $SM_b$  the section modulus for the bottom.

For this condition the formula for the stresses in the top of the sill is  $S = \frac{P}{A} - \frac{PX}{SM_t}$

and, for the stress in the bottom of the sill,  $S = \frac{P}{A} + \frac{PX}{SM_b}$ .

To find the ratio of stress to end load for this condition that

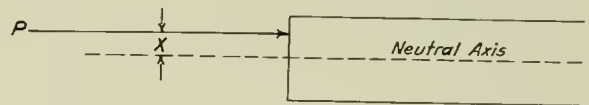

Fig. 2

value of  $S$  should be used which is a maximum. This is ordinarily at the bottom, and is  $\frac{S}{P} = \frac{I}{A} + \frac{X}{SM_b}$ .

In Fig. 2, the end load is shown applied above the neutral axis, and in this case the stress in the top of the sill is  $S = \frac{P}{A} + \frac{PX}{SM_t}$  and for the bottom is  $S = \frac{P}{A} - \frac{PX}{SM_b}$ . Unless the difference in the section moduli of the two sides of the sill is so great that the stress in the bottom is greater than the stress in the top, the ratio of stress to end load is

$\frac{S}{P} = \frac{I}{A} + \frac{X}{SM_t}$ . If the center line of the buffing load coincides with the neutral axis of the sill the eccentricity  $X$  is zero and  $\frac{S}{P} = \frac{I}{A}$ .

It is evident that the specification, requiring a ratio of stress to end load not to exceed .06, fixes the minimum

strength of the sills. If we assume that  $S = 21,000$  lb. per sq. in. as a safe unit stress for the material, then the safe buffering capacity of the sills will be  $\frac{21,000}{.06} = 350,000$  lb.

Assuming, as recommended by the committee, that the sill stresses due to loading may be neglected, then the simple fixing of this constant for steel sills definitely fixes the requirements for buffering strength without reference to the eccentricity of the application of end load, or other conditions of the details of design.

### TANK CAR SPECIFICATIONS MODIFIED

The Master Car Builders' Association has issued Circular No. 17 modifying the standard specifications for tank cars to conform to the recent ruling of the Interstate Commerce Commission. The circular is as follows:

The Interstate Commerce Commission upon the recommendation of Colonel Dunn, chief inspector, Bureau of Explosives, following the explosion and fire at Ardmore, Oklahoma, September 27, 1915, in connection with tank car loaded with casinghead gasoline, issued an order January 20, 1916, modifying its Regulations, paragraph 1824 (k), governing the transportation of liquefied petroleum gas (casinghead gasoline).

The requirements of the order, including 25-lb. setting for safety valves and the automatic venting of pressure, become effective March 15, 1916, as to tank cars for casinghead gasoline shipments; and on January 1, 1917, these two requirements become effective as to all tank cars for shipment of inflammable liquids with flash point lower than 20 deg. F. The requirement that tank cars for the transportation of the products described in the order shall have their safety valves set to open at a pressure of 25 lb. per sq. in. by the dates fixed, makes necessary in the case of such cars a modification of the M. C. B. standard specifications for tank cars, now requiring 12-lb. setting for safety valves for ordinary tank cars.

To set the safety valves to open at a pressure of 25 lb. per sq. in. requires the removal of the present spring for 12-lb. setting and the substitution for it of a new spring meeting the following specifications:

Diameter of bar.....	9/16 in.
Outside diameter of coil.....	6 3/8 in.
Length of bar.....	80 3/8 in.
Tapered length of bar.....	95 in.
Height, solid.....	2 3/4 in.
Load, solid.....	1,005 lb.
Minimum height with load of 500 lb.....	5 1/2 in.
Maximum free height.....	8 1/4 in.
Normal weight.....	6 lb. 1 oz.
Minimum weight.....	5 lb. 10 oz.
Coiling.....	Right or left hand
Ends ground.....	

This spring can be inserted in the spring case of the present standard 5-in. safety valves in place of the 12-lb. spring now used. The present spring for 12-lb. setting must not be used for 25-lb. setting, as any attempt to set the valve for the increased pressure by screwing up on the 12-lb. spring will cause the spring to go solid, and the valve will no longer be a safety valve.

In stenciling the test record on the tank after testing at the 25-lb. pressure, the words "with 25-lb. spring" must be added to the stenciling now required by the specifications, thus:

SAFETY VALVES WITH 25-LB. SPRING	
Tested (date).....	.....
Pressure (lb. per sq. in.).....	.....
At (place).....	.....
By (name of firm).....	.....
(No change in the requirement as to stamping date of test and pounds pressure to which valve was tested on body of valve.)	

To comply with the order as to automatically venting the pressure in the tank before the dome cover is removed, an approved method for the modification of existing dome covers consists in drilling horizontally through the bottom flange six 1/2-in. holes, at root of the screwed portion, as close as

possible under the top flange. Where the length of the screwed portion is not over 1 1/4 in., it is recommended that not less than nine 5/16-in. holes be drilled, instead of the six 1/2-in.

Any other arrangement which will insure the relief of internal pressure before the removal of the dome cover will be acceptable if first submitted to and approved by the Master Car Builders' Association.

### TURNING CAR JOURNALS

An interesting arrangement of a lathe for turning car journals in use at the Clinton shops of the Chicago & North Western, is shown in the accompanying illustration. The lathe is located in a pit sufficiently deep to bring the ways at the approximate level of the floor. The car wheels are rolled in through the door shown in the background, and onto the

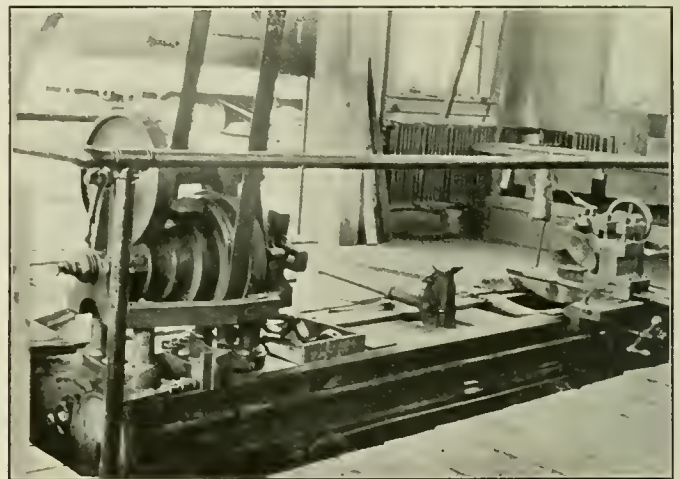

Arrangement of a Lathe for Turning Car Journals

lathe over iron bars extending between the ways and the floor. The wheels are raised to the proper position for the centers by the hand-jack located between the ways. By this method it is an easy matter for one man to handle the entire work, as the machine may be loaded with but very little effort.

### LETTER BOARD SPLICE

The illustration shows a horizontal section through a coach letter-board splice which is in use on the Canadian Northern. With other types of joints and splices which have been tried considerable trouble has been experienced from the opening up of the joint at the surface and the warping of the boards

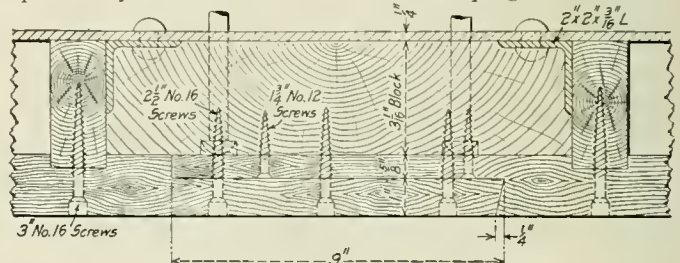

Canadian Northern Letter Board Splice

near the ends. The new splice was developed to overcome these difficulties.

The construction of the splice is clearly shown in the drawing. As will be seen the surface portion of the joint is beveled so that the warping of the overlapping tongue is prevented. The splice is shown as applied to the road's recently built composite steel and wood passenger equipment.

# LIFE AND MAINTENANCE OF STEEL CARS

A Discussion of the Life, Depreciation Rates, Deterioration, Rebuilding and Painting of Steel Cars

BY M. K. BARNUM

Superintendent of Motive Power, Baltimore & Ohio

When the first steel cars were built, the advocates of this form of construction claimed that these cars would be practically indestructible, and their life so much greater than that of wooden cars that it was very difficult to estimate it. A few years later, when steel cars came into general use on the larger railroads, the estimates of their life were placed at from 25 to 35 years, and in calculating the rate of depreciation, many roads adopted three per cent per year, whereas for wooden cars, it had for a long time been calculated at six per cent. It is now nearly 30 years since the first steel cars were built, and there has been a considerable difference in their durability. This has been found to vary according to the manner in which they have been maintained, the part

many thousands of steel gondola and hopper cars only 14 and 16 years old which have the sheets and underframes so weakened by corrosion and service that they do not justify the application of new material for general repairs, and many of these cars are now being destroyed on account of the bodies having reached their limit of life. This is about one-half the life which was originally expected from steel cars, and it is disappointing. It naturally follows that those roads which have calculated the depreciation of steel freight cars at three per cent, and now find many of them worn out at the age of 14 to 16 years, must charge quite a large amount to operating expenses when they have to be scrapped. If we assume the average life of a steel gondola car which cost \$1,000, as



Fig. 1.—Steel Hopper Car 20 Years Old; 80,000 lb. Capacity; Light Weight, 41,900 lb.

of the country in which they have been mostly used, and somewhat with the character of the lading. However, the life of steel freight cars is much less than was expected.

So far as the writer has been able to learn, the oldest steel freight car now in service belongs to the Bessemer & Lake Erie. It was built in 1896, twenty years ago. The frame of this car was made of structural steel shapes, and it weighed nearly 42,000 lb., about 4,000 or 5,000 lb. more than many cars of the same capacity which were built later. Fig. 1, from a photograph taken in 1915, shows that the design of this car compares very favorably with the latest methods of construction, and also indicates that it has been very well maintained. The record of repairs shows that it has been kept well painted, this being the usual practice of the Bessemer & Lake Erie. Some of the doors and hoppers required new sheets after about nine years and at 14 or 15 years of age the floor sheets required extensive renewals and the side sheets and stakes had some repairs. At 18 years it received a new floor, two new corner side sheets, eight new hopper sheets and other repairs, and its appearance indicates that it may be good for at least 10 years more.

This car is apparently an exceptional case, for we find

16 years, and the scrap value of the car to be \$200, five per cent per year would be about the proper depreciation rate.

## LIFE OF WOODEN COAL CARS

The records of a number of roads owning large numbers of wooden coal cars show that their life has varied between 16 and 20 years, and the average life has been about 17 years. This class of equipment has usually been condemned and dismantled on account of the underframes and draft attachments becoming worn out and too weak for the heavy modern trains of coal cars. But for this reason, the life of these cars undoubtedly would have been about 20 years, which is the average life of a box car. However, in comparing the life of wooden coal cars with that of steel, we should bear in mind the fact that most of the wooden cars are of 20 and 30 tons capacity and few, if any, are over 40 tons, whereas few steel coal cars have been built of less than 40 tons capacity and the majority of them carry 50 tons, while some are now being built to carry 75 and 90 tons.

## LIFE OF IRON AND STEEL BRIDGES

The writer has obtained the views of a number of bridge engineers and engineers of maintenance of way, and most of

them say that the life of iron and steel bridges varies indefinitely, so far as actual durability is concerned, provided they are kept well painted, as they usually are, and the ordinary repairs are maintained. In some cases iron bridges 30 and 40 years old have been perfectly good so far as deterioration is concerned and have only been removed on account of the locomotives and cars becoming too heavy for their construction. Bridges which are exposed to salt air and water corrode rapidly and their life is comparatively short, and salt water drippings from refrigerator cars used for shipping fresh meat tend to corrode the girders quite rapidly where the amount of this class of business is large. In comparing the life of iron and steel bridges with that of steel freight



Fig. 2—A Car Four Years Old Badly Rusted on Account of Not Being Repainted at the Proper Time

cars, we find the principal differences to be that the bridges are kept well painted and their life is not shortened as much by corrosion as is that of freight cars which are not kept painted on the inside. Many cars are not kept painted on the outside, and they are subject to more severe and frequent shocks in service.

#### LIFE OF LOCOMOTIVE TENDERS

The locomotive tender more closely approaches the steel coal car in the service to which it is subjected and will afford a fairer comparison on this account. Locomotive tenders are usually kept well painted on the outside, and whenever the locomotive receives general repairs, ordinarily once in about two years, it is thoroughly cleaned and painted outside, and often a coat of paint is applied to the coal space and to the top



Fig. 3—A Steel Car Five Years Old in Which the Hopper Sheets Required Renewal on Account of Corrosion; Note the Rusted Condition of the End, Stiffening Rib and Buffer Plate

and bottom sheets. Many locomotives, thirty or more years old, still have the original tender in fairly good condition. The inside sheets have sometimes been renewed, but the original outside sheets often are in a fair state of preservation.

#### PRINCIPAL CAUSES OF SHORT LIFE OF STEEL CARS

There are many causes which tend to shorten the life of steel cars and the most active of these is corrosion. New steel cars are painted inside and out, but very few, if any, railroads attempt to keep the inside painted after the cars



Fig. 4—A Steel Gondola Car Weakened by Corrosion and Buckled by Service Shocks

have gone into service, as it is thought that the effect of loading and unloading coal, ore, etc., is to wear the paint off so quickly that it would not last long enough to pay for the cost of the application. Therefore, the corrosion of the inside of such cars generally starts within a few months after they go into service. The paint on the outside varies in durability according to quality, the number of coats applied, and the manner of application, but it is nothing unusual to see cars only two or three years old the sides of which have begun to rust quite badly and Figs. 2 and 3 show cars only five

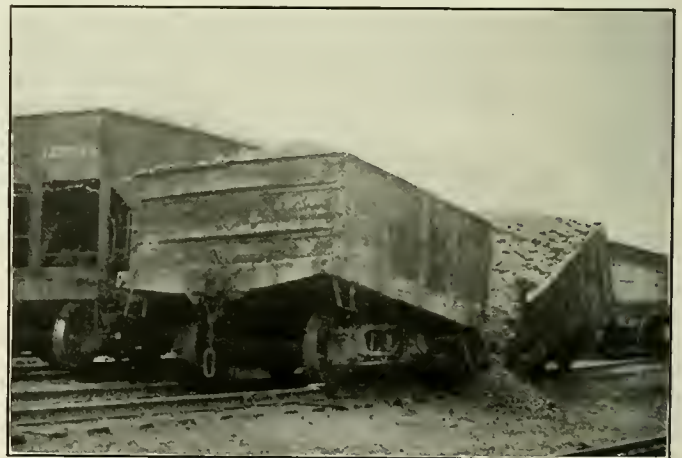

Fig. 5—A Steel Gondola Car Weakened by Corrosion to Such an Extent That It Finally Failed Under an Ordinary Load

years old which had but little paint left on them. It is pretty certain that if these cars had been repainted when two or three years old, before the rust had become so general, the corrosion on the outside would have been stopped and the life of the side sheets prolonged.

Some of the earlier steel cars were built so light, that they have become weakened by corrosion sooner than those of heavier construction, and such cars occasionally buckle up in trains as shown in Figs. 4 and 5. In designing steel cars, it has been a nice problem to determine just how far to go in putting in metal to increase the strength, and at the same time to cut out metal where it is not essential so as to keep the

dead weight down to a minimum consistent with good service. In this respect, the practice of different roads varies so that we still see steel gondola cars of 100,000 lb. capacity weighing only about 38,000 lb., while others of the same capacity weigh 7,000 or 8,000 lb. more. This matter of keeping down the dead weight has always been a hobby of such prominent railroad builders as E. H. Harriman and J. J. Hill, and little argument is needed to prove the desirability of keeping the



Fig. 6—A Steel Gondola Damaged Beyond Repair; the Two Ends Were Doubled Together in an Accident About as Shown in the Photograph and It Was Cut Apart to Facilitate Loading

dead weight as low as may be consistent with satisfactory service. The tendency during the past four or five years has been to increase, somewhat, the weight of cars, but this has generally been done, not by using thicker sheets for the sides and bottoms, but by strengthening the sills and reinforcing the top edges of the sides and ends, and also by adding more substantial draft gear. These improvements should increase somewhat the life of these cars over those of earlier design.



Fig. 7—A Drop Bottom Gondola with Floor and Sides Rusted so That no Sheets Were Fit for the Application of New Material

but in view of the heavier trains in which they are used it remains to be seen how far this will prove true. These problems of keeping down the dead weight of cars and eliminating those of weak design are not new, for in the proceedings of one of the earliest meetings of the Master Car Builders' Association, held nearly 40 years ago, we find a lengthy discussion about these same questions and at that time it was the con-

sensus of opinion that in the 15-ton car the maximum capacity had finally been reached.

Other causes of the short life of steel cars are the strains to which they are subjected in unloading machines and also the use of sledges and bars in pounding the sides and hoppers when the coal freezes or clogs and requires loosening. Some of the later designs of cars are provided with holes framed into the sides and hoppers, through which bars can be introduced to loosen the coal when it lodges. Another cause of shortening their life is the heavier trains in which they are used, resulting in greater shocks than those for which they were originally designed. The effect of climate has quite an important bearing on the life of steel cars as there is a noticeable difference in the rapidity of corrosion of cars used mostly in proximity to salt water and to rivers where fogs are prevalent, and those which are kept principally in service in the dry climate west of the Missouri river. The writer's observations lead him to believe that corrosion is probably 25 per cent more rapid in the vicinity of the salt water than in the drier climate of the interior. The nature of the loading also affects the deterioration. One road which uses steel hopper cars almost entirely in iron ore service reports that, "as yet none of them show any effects of deterioration due to rust," although they are about 16 years



Fig. 8—Rusted Floor Sheet Cut from a Hopper Coal Car with a Broad Axe as Shown in Fig. 9

old. Coal having much sulphur and other impurities is more injurious to steel sheets than the better grades of coal, and wet ashes from cinder pits are especially active in hastening corrosion.

#### DIFFICULT PROBLEMS

For the first five or six years of the life of a steel car the repairs are light and it is easy to decide just what work should be done, but after eight or ten years the floor and hopper sheets of many cars have become so corroded that they must be renewed, and in some cases the sides also rust through at the ends and bottom while the rest of the sheets are worth preserving. After a few years more many cars become so generally corroded that it is doubtful whether the side sheets are strong enough to make it advisable to rivet new bottom and hoppers to them. Then the problem is whether to apply new side sheets, if the car has already had a new bottom and hoppers; or, in cases where these have again become weakened, to give the car general repairs using such of the original parts as may yet be serviceable; or to build an entire new body using the same trucks; or to dismantle the car entirely and eliminate it from the equipment list. Under these conditions the program will be more or less affected by the capacity of the car and the desirability of improvements in the design and the operating mechanism.

When steel cars become damaged in wrecks, the question of repairs is quite a different one from that of repairing wooden

cars, as in the latter case the damaged parts are removed and replaced with new sills, siding, flooring, etc., at a considerable expense for material. On the other hand, unless a steel car is damaged almost beyond recognition, the various parts can generally be straightened out and replaced on the car, if they were previously in good condition. One road, owning over 100,000 steel coal cars, has lost only about 20 of them on account of being damaged beyond repair, but if these had been wooden cars, probably many hundreds of them would have been destroyed within the same period.

On another road which has over 50,000 hopper and gondola cars, only about two per cent of the all-steel cars were damaged beyond repair during the first 12 or 13 years of their life, but of the composite cars having steel frames and wood



Fig. 9—Broad Axe Made by Drawing Out One End of a Sledge, and the Manner of Using It to Cut Rusted Steel Sheets

sides and bottoms, about 11 per cent were destroyed. This large difference was probably affected to some extent by the fact that the composite cars were not originally as well designed as the steel cars, but after making due allowance for this, the all-steel cars seem to have the advantage over the composite cars in the matter of durability.

#### REBUILDING STEEL CARS

On a road which owns a large number of steel gondola and hopper cars, the latter have been found to reach the limit of the profitable life of the body in about 13 or 14 years. When the cars were from eight to ten years old, it became necessary to renew the floor and hoppers, and in about four or five years more, the sides and other parts had become practically worn out, so that it was very doubtful whether the bodies were worth the application of more new material for repairs. A study of the subject indicated that an entire new body would cost only about \$25 more than general repairs to the old body,

retaining such parts as might be fit for further service. The trucks were in good general condition so that with the renewal of some worn parts, they could be made practically equal to new. The body after receiving general repairs was estimated as worth only about 65 per cent of the value, new, of a gondola and 75 per cent of a new hopper car, whereas the general repairs would probably not extend the life of the car more than six or eight years. The repaired car, if destroyed on a foreign line, would have its depreciation calculated from the date of its original construction, whereas the new body would have its depreciation calculated from the time when the body was built, which made a good argument in favor of a new body.

Other points in favor of the new body were that with the experience obtained from the maintenance of the old bodies, some improvements in the design were possible which would make the new body more satisfactory in service and better able to withstand the effects of heavy trains, dumping machines, etc. It would also have the further advantage of not being on the repair tracks as often as the repaired car. It was, therefore, decided to buy new bodies to replace the old hopper bodies of 100,000 lb. capacity and use the air brakes, couplers, draft gear and trucks of the old cars under the new bodies. In the case of the 80,000 lb. gondolas it was not

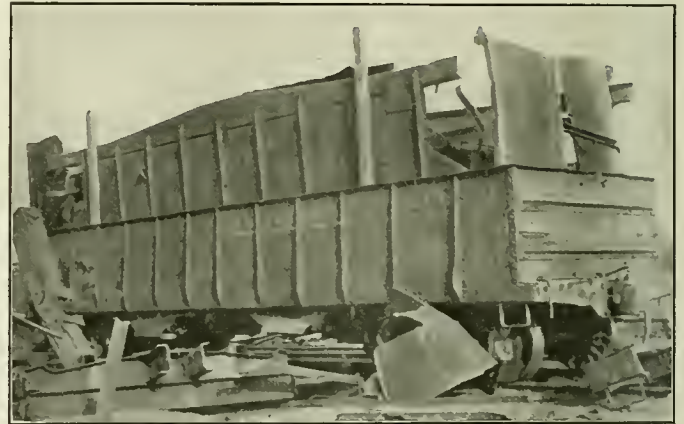

Fig. 10—Car Partly Loaded with Scrap Sheets from Hopper Coal Cars Showing the Extent to Which It is Necessary to Cut Cars Down to Prepare Them for Sale and Shipment

thought profitable to perpetuate a steel car of this capacity, and therefore it was decided to use the trucks and other serviceable parts under new box and stock car bodies of 80,000 lb capacity. Figs. 4, 5, 7 and 8 illustrate some of the conditions found in the cars which had reached the limit of their life on account of the sheets being so generally weakened by corrosion that there was not enough good material left in the bodies to justify general repairs. Fig. 9 shows the method of cutting down the bodies of these old steel cars by using a heavy broad-axe to cut the thinner sheets. The oxy-acetylene blow-pipe process is used to cut the angles, sills and heavier sheets. By these methods, the total cost of cutting down a condemned steel hopper car body to sizes suitable for sale, was less than \$6, including both labor and oxy-acetylene gas. Figs. 8 and 10 show the extent to which the old cars are cut up so as to be acceptable to the purchasers of scrap. Some of the end sills, gussets, side stakes and other parts of the condemned cars were considered worth saving for repairs to other cars which are to be maintained for a time and Fig. 11 shows a car load of this serviceable second hand material.

#### PAINTING STEEL FREIGHT CARS

There has been a good deal of discussion as to whether or not it pays to keep steel coal and ore cars well painted and the majority of superintendents of motive power believe that it would pay to do so, but many of the higher officers who are responsible for the entire cost of operation seem to have con-

cluded that it does not pay to paint them except when they receive new sheets or the letters and numbers need to be brightened up so that their ownership and identity can be distinguished. A committee of the Master Car Builders' Association investigated this subject several years ago and their conclusions as presented at the 1908 convention were as follows:

"We cannot be too emphatic as to the necessity of taking the proper care of the exterior, and regret that we are not able to give the interior the same care.

"The painting of the inside of steel cars has been thought by some to be beneficial, but your committee can see no lasting results in this, and do not recommend it, but is of the opinion that coating the interior of the cars about once every six months with black oil would act as a preservative."

During the following year a number of cars were painted with different mixtures for test purposes and special attention was given to painting the insides of the cars. At the 1909 convention the committee reported upon the painting of the inside of cars as follows:

"One car bearing mixture No. 4 was examined after being in service 4 months and 17 days and shows the inside well preserved, but considerable of the paint gone from the bottom, yet there seemed to be retardation of the rusting and no accumulation of scale. This mixture shows better results than mixtures Nos. 1, 2 and 3." (Mixture No. 4 consisted of 30 lb. of tar, 40 lb. of aniline oil and 170 lb. of corn oil.)

However, the committee's conclusions were, "It will be a very hard matter to find a preservative that will take care of the interior. The best preservative is to keep the cars in active service. Some steel cars that have been in active service for 10 years have the plates in excellent condition and from appearances, they are good for 10 years more. It is a pretty well known fact that where cars stand idle for a couple of months, the deterioration of plates on the inside is equal to two or three years' service."

Similar opinions were expressed by several of the members of the Association who took part in the discussion. So far as the exterior of the car was concerned, practically all those discussing the report gave it as their opinion that they should be kept well painted. Nevertheless, this practice has not been generally followed.

As to the frequency with which steel cars should be painted, there is quite a difference in opinion. Some roads paint them once in every three years, others once in four or five years and



Fig. 11—Car Load of Serviceable Pressed Steel Shapes Saved from Dismantled Hopper Coal Cars for Repairs to Other Cars of the Same Class

others only when they receive new sheets in the course of repairs. Estimates of the cost of painting also vary widely, and as might be expected, those roads which paint their cars most infrequently are the ones on which the cost of painting is high, varying from \$5 to \$10 for each painting, while those roads which keep their cars well painted report the cost as varying from \$6 to \$1 for each painting. There would naturally be a considerable variation in the cost per painting according to the kind of material, the class of labor used and the condition of the car when painted, but a comparison of the figures indicates that it costs but little more during the life of the car to keep it well painted than it does to paint it only when the car becomes badly corroded and requires more thorough treatment.

The difference in the average age and condition of such

cars as have been kept well painted and those which have not been so well maintained, makes it seem fair to conclude that thorough painting will probably prolong the life of steel freight cars between 25 and 50 per cent. Assuming that the average life of a car is 16 years, and that the cost per painting would be \$5, it seems very probable that an expenditure of \$25 or \$30 additional for painting would prolong its life one third, or about five years. This is a conservative estimate and it would certainly be a good investment when applied to cars costing \$1,000 apiece. Some other arguments in favor of keeping steel cars well painted are, that it will help to prevent their becoming weakened by corrosion so that they are liable to buckle up in heavy trains, also that the appearance of cars will be much better and although this may have no commercial value, yet it tends to create a favorable impression



Fig. 12—Side Sill of a Steel Car Seven Years Old, Showing Corrosion Due to Lack of Paint

about the owning road. The arguments which are often advanced against keeping steel coal and coke cars thoroughly painted, seem frequently to be applied to steel underframes and other parts of cars which do not come in contact with the lading, and these are often found to be so corroded that their life is much shortened. (See Fig. 12.)

#### STEEL PASSENGER CARS

The estimated life of steel passenger cars has been placed by various authorities at from 30 to 50 years, but as none of them are yet half that age there is no data at hand on which to base any definite conclusions. The elements affecting the deterioration of steel passenger cars are different from those which apply to freight cars but several years' experience with such cars show conclusively that they must be kept well painted or they will deteriorate more rapidly than wooden cars. Cases have been noticed where the doors and window frames which were made of pressed steel shapes, have begun to rust badly within two or three years and for this reason the Pullman Company and some railroads have returned to the use of wooden window sash in their more recent equipment. Also some of the railroads that used metal doors on their first steel passenger train cars found so many objections to them that they have been discarded and wooden doors used in the later cars. The parts of steel passenger cars which start first to rust are the roofs and the moldings or joints between the sheets at the clerestories and eaves, and there can be no doubt about the importance of keeping these parts well painted.

#### CONCLUSIONS

*First.*—The average age of steel gondola and hopper cars will probably be about 16 years, judging by the records of those cars which have already reached their limit of life.

*Second.*—The depreciation of steel gondola and hopper cars should be calculated at about five per cent.

*Third.*—It will pay to keep steel cars well painted on ac-

count of preserving their strength and improving their appearance and extending their life.

Since the notes and photographs used for this article were made, there was presented at the December meeting of the Pittsburg Railway Club a paper on "The Life of a Steel Freight Car,"\* by S. Lynn, master car builder of the Pittsburg & Lake Erie and it is interesting to note that the points mentioned in his paper as well as those brought out in the discussion, agree in most of the essential facts with the observations and conclusions contained in this article. Two statements made in the discussion are especially worth quoting, namely:

"If the steel car was given reasonable treatment and repairs made when needed, and repainted when the steel became exposed to the weather, the renewing of some of the parts would not become necessary for a longer period than is now the case."

"One of the most important things determining the life of a steel car is the question of maintenance. If you spend the right amount of money at the right time, you can get prolonged life and service."

## CAR FOREMAN'S RESPONSIBILITY FOR AIR BRAKE CONDITIONS†

BY LAWRENCE WILCOX

Mechanical Expert, Westinghouse Air Brake Company

The value and importance of air brakes as a factor in railroad operation are universally recognized. In fact no other single factor has done as much to increase train carrying capacity, reduce ton-mile costs, shorten train schedules, make high speeds safe and limit the loss and damage claims, as the air brake. Notwithstanding this, it is impossible to handle, with the proper and desired degree of safety and economy, the thousands of trains that make up the daily schedule of our railroads without having the air brake in good operative condition. There are certain definite functions which the brake is designed to perform; whether it performs these functions properly depends upon the manner of its installation, maintenance, and manipulation.

Through the co-operation of the railroad companies and the manufacturers the brake installations on modern cars are, as a rule, satisfactory. However, even with a well designed brake properly installed, the railroad cannot without good maintenance and manipulation get the most out of its investment. Air brakes cannot be operated in a manner to produce the desired smooth and safe train operation unless they are properly maintained; therefore, as the latter depends almost wholly upon the knowledge and ability of the car foreman, his position is indeed an important one, and the effects of his success or failure are far reaching. The car foreman should know the conditions of the air brakes on the cars that come under his jurisdiction; that the men he employs to do air brake work are competent and conversant with the rules and instructions affecting them, and should see that the air brake work performed is of proper character, quality and quantity. He should have a good working knowledge of air brakes. That does not necessarily mean that he must be able to trace the course of the air through the valves, or know the number, size or location of the ports and passages, but his knowledge should be of such character and extent as will enable him to determine when a brake is in good working order.

Brakes should be tested with a service reduction at the proper rate to insure the condition of the brake being such that it will apply and remain applied when placed in the train. There is no economy in re-applying triple valve gas-

\*For an abstract of this paper see the *Railway Mechanical Engineer* for January, 1916, page 29.

†Abstract of paper presented at the February meeting of the Car Foremen's Association of Chicago.

kets that are hard, cracked or sufficiently disfigured that they are likely to cause leaks. An angle cock, that points straight down or toward the outside of the track instead of toward the center, or that is not located according to the M. C. B. Standard, will cause brake pipe leakage at hose couplings and the bending and straining of the air hose which will result in their rapid deterioration. Piping that is not properly clamped will cause leaky pipe joints, broken pipes and shifting of angle cocks to wrong location. A brake cylinder and auxiliary reservoir not held rigidly will cause broken pipes and leakage at the pipe joints. Brake cylinders and auxiliary reservoirs which do not have a bearing on their supporting brackets adjacent to the bolt holes, will be distorted and strained when the bolts are tightened, which is likely to cause cylinder leakage or fracture the castings. Cars leaving repair tracks with defective and porous hose are a cause of excessive brake pipe leakage, trouble on the road and are often the cause of expensive accidents. The application of levers of improper dimensions and proportions causes brake rigging failures, slid-flat wheels, improper and unequal braking power, and is detrimental to train handling.

Changing brake shoes without re-adjusting the piston travel to between 7 in. and 8 in. is often the direct cause of slid-flat wheels, break-in-twos, shocks in trains, and prevents proper manipulation of the train. Permitting passenger equipment cars to leave terminals with automatic adjusters at, or near their maximum take-up position, will prevent a valuable device performing its functions, and therefore prevent its assistance toward proper manipulation. Permitting a car to leave the shops and repair tracks without blowing out the brake pipe is not giving the triple valve on that car, or on other cars in train, a fair show. Applying triple valves to cars without seeing that the branch pipe strainers are inserted and in good condition, and failure to clean dirt collectors at proper intervals, deprives the triple valves of the protection due them.

An egg-shaped expander ring applied to a brake cylinder will cause the brake to be inefficient almost immediately after cleaning and will soon wear the packing leather through at point where it bears heaviest against the cylinder wall. When this occurs the brake is inoperative, necessitating an additional expenditure of labor and material. A car, which leaves a repair track without having the retaining valve and piping tested, stands a good chance of being set out for air brake work, if required to operate under grade conditions. Testing a retaining valve without ascertaining that both exhaust ports are open, is inviting slid-flat and brake burnt wheels. These few illustrations will convey some idea of the importance and value of the car foreman, who properly supervises air brake work.

The car foreman should co-operate with, and obtain all the assistance and instructions possible from the air brake instructor, and encourage the men under him to do likewise. This interchange of ideas will result in mutual benefit and education to the car foreman, the air brake repair man and the air brake instructor. The car foreman must be held directly responsible for knowing absolutely that the man who is actually doing the job is turning out a product of proper character, quality and quantity. The utmost skill and judgment that can be exercised by the man who manipulates the brakes can only partially compensate for brake equipment carelessly tested and poorly maintained.

GUARDING OVERHEAD BELTS.—Overhead driving belts, and, in fact, all overhead belts, should be so guarded as to prevent their falling on workmen in case of breakage. Recently a workman was badly injured by a driving belt because it was not properly protected, and investigation in the same shop showed five other belts lacking guards. While the falling of a belt may not be a life-and-death matter, it may easily result in a serious accident.—American Machinist.



# SANTA FE REFRIGERATOR CARS

## Special Features Are the Ventilators, Draining Attachments and the Application of the Insulation

During the past year the Atchison, Topeka & Santa Fe has purchased 500 refrigerator cars which embody several interesting features in their design. They are of wooden construction, with metal draft members in the underframe, and steel carlines; each weighs 52,000 lb. and has a capacity of 60,000 lb. They are equipped with collapsible bulkheads, which increases the cubical capacity some 15 to 20 per cent when not loaded with refrigerated freight. Complete plans and specifications were prepared by the railway company, and the cars were built by the American Car & Foundry Company. The following are the general dimensions:

Length over end sills.....	41 ft. 3 in.
Width over end sills.....	9 ft. 13/4 in.
Width at eaves.....	9 ft. 6 7/8 in.
Width, inside.....	8 ft. 2 3/4 in.
Height, inside, clear space.....	7 ft. 3 in.

The beams supporting the truss rod queen posts are 9 in., 15-lb. channels, which are secured to the draft channels by top and bottom gusset plates. There are six truss rods, 1 1/4 in. in diameter. The body bolsters consist of 3/4-in. by 10-in. top and bottom cover plates riveted to malleable iron fillers and to the draft channels, and bolted to the longitudinal sills. The body side bearings are pressed steel and slide on roller truck side bearings. Drop-forged body center plates applied with 11/16-in. shims are riveted to the bolster with 7/8-in. rivets.

The framing is made up of 2-in. by 5-in. side posts and braces, 3-in. by 4 3/8-in. end posts and braces, 4-in. by 6-in. corner posts, 5 3/4-in. by 5 1/2-in. door posts, and 24 vertical 5/8-in. tie rods. There are two belt rails at the sides and ends, located about 16 1/2 in. and 4 ft. 4 1/2 in. above the

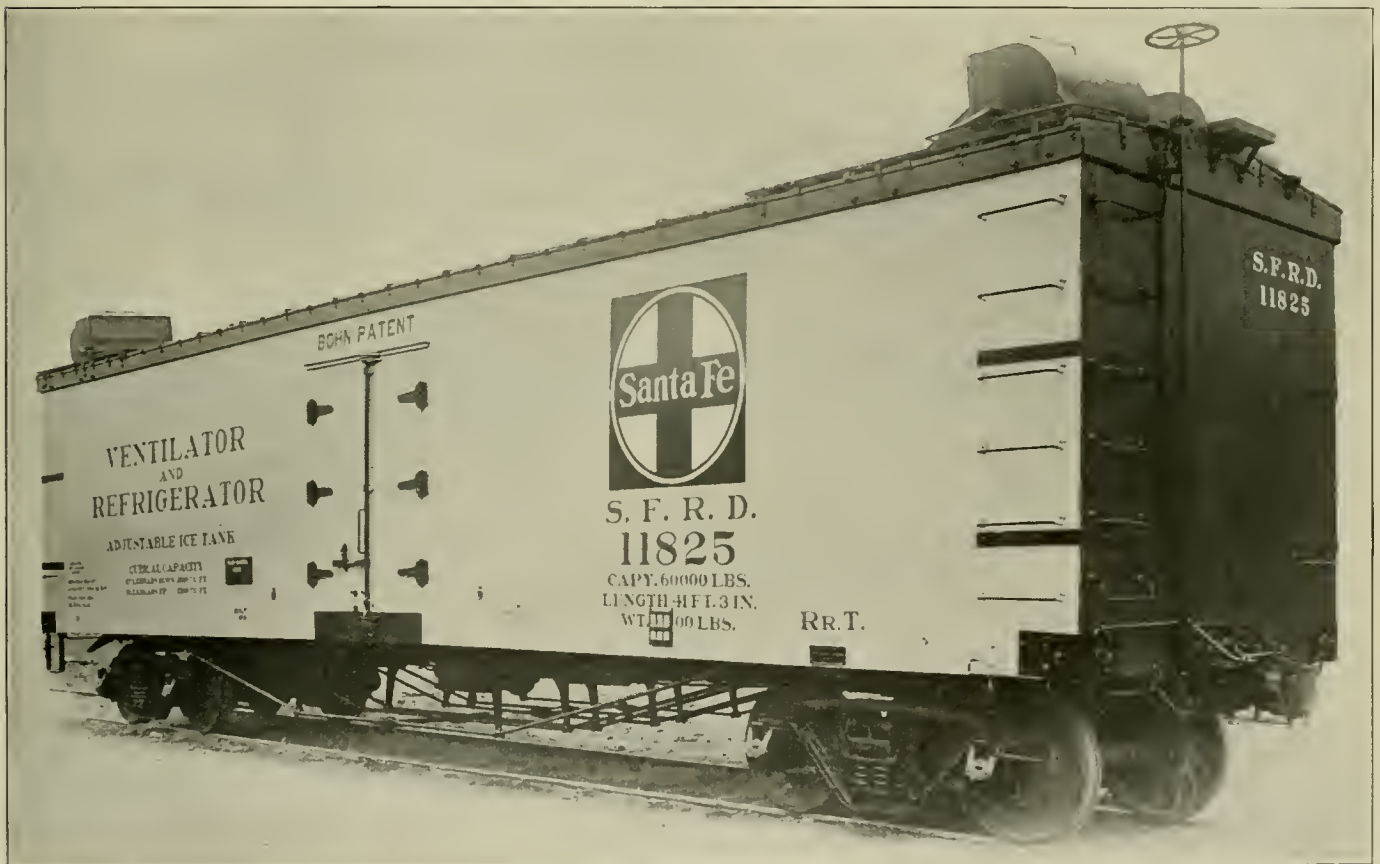

A. T. & S. F. Refrigerator Car

Wheel base, total.....	36 ft. 3 in.
Wheel base, truck.....	5 ft. 4 in.
Length inside, bulkheads up.....	39 ft. 2 3/4 in.
Length inside, bulkheads down.....	33 ft. 2 1/4 in.
Height, top of running boards.....	12 ft. 7 7/16 in.
Height, top of brake shaft.....	14 ft. 1 1/8 in.

The underframe is of the truss rod type, this being the standard of the road for refrigerator cars. There are six 5-in. by 9-in. longitudinal sills, the center sills being reinforced by two 9-in., 21.5-lb. channels which serve as the draft members. The end sills consist of two oak timbers 4 in. by 10 5/8 in. by 9 ft. 1 3/4 in. bolted together with six 5/8-in. bolts and mortised to receive the longitudinal sill-pockets. All the sills are covered on top, and the side sills are covered partly on the outside with Waterdyke felt. The

floor. The cripple belt rails which extend between the posts and braces are 2 in. by 5 in. The belt rail liners, which are continuous pieces, are 1 3/4 in. by 2 1/2 in. The side and end plates are 5 1/2 in. by 8 in. and 3 in. by 13 in. respectively. The outside sheathing and the lining are 13/16 in. thick, and the flooring is 1 5/8 in. thick. The roof structure consists of two purlins 3 3/8 in. by 4 1/2 in., a 3 1/2-in. by 5 1/2-in. ridge pole, six steel carlines of 4-in., 9.5-lb., I-beam section, and 13 wood carlines. The I-beam carlines are cut and shaped as indicated in the drawings. This type of carline is peculiar to Santa Fe freight cars and provides a substantial support for the superstructure. The ceiling is 5/8 in. thick, and the roof 13/16 in. thick. The Standard Rail-

way Equipment Company's outside flexible metal roof is used.

An interesting feature in the insulation of these cars is the method in which it is applied. Four layers of 1/2-in. Flaxlinum are applied, one against the other, with no air space between them. Air spaces are provided on either side of the insulation, however, the space between the outside sheathing and the insulation being about 3/4 in. wide, and that between the lining and the insulation 2 in. wide. This construction is easier to build than one in which the air spaces are provided between the layers of insulation, and it is expected that it will stand up better in service. It also simplifies the making of any repairs that may become necessary.

The side sills are gained out 1 1/2 in. by 1 11/16 in. to receive two layers of the Flaxlinum. The other two layers start from the floor. All four layers are waterproofed up to a point 1 1/2 in. above the floor, and the entire length of the

sides, except that the space between the insulation and the inside sheathing is 4 3/8 in. wide. One layer of the insulation completely surrounds the car, passing over the corner

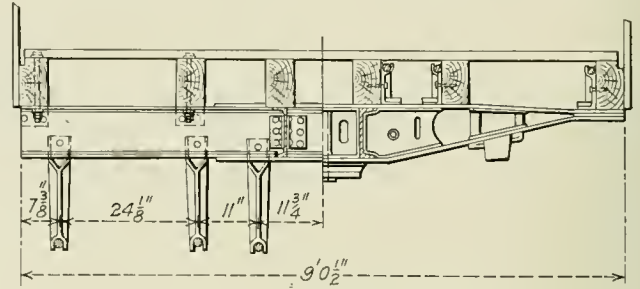

Half-Section Through the Underframe

posts. In the roof there is one layer that completely covers the car, passing over the purlins and carlines. The other

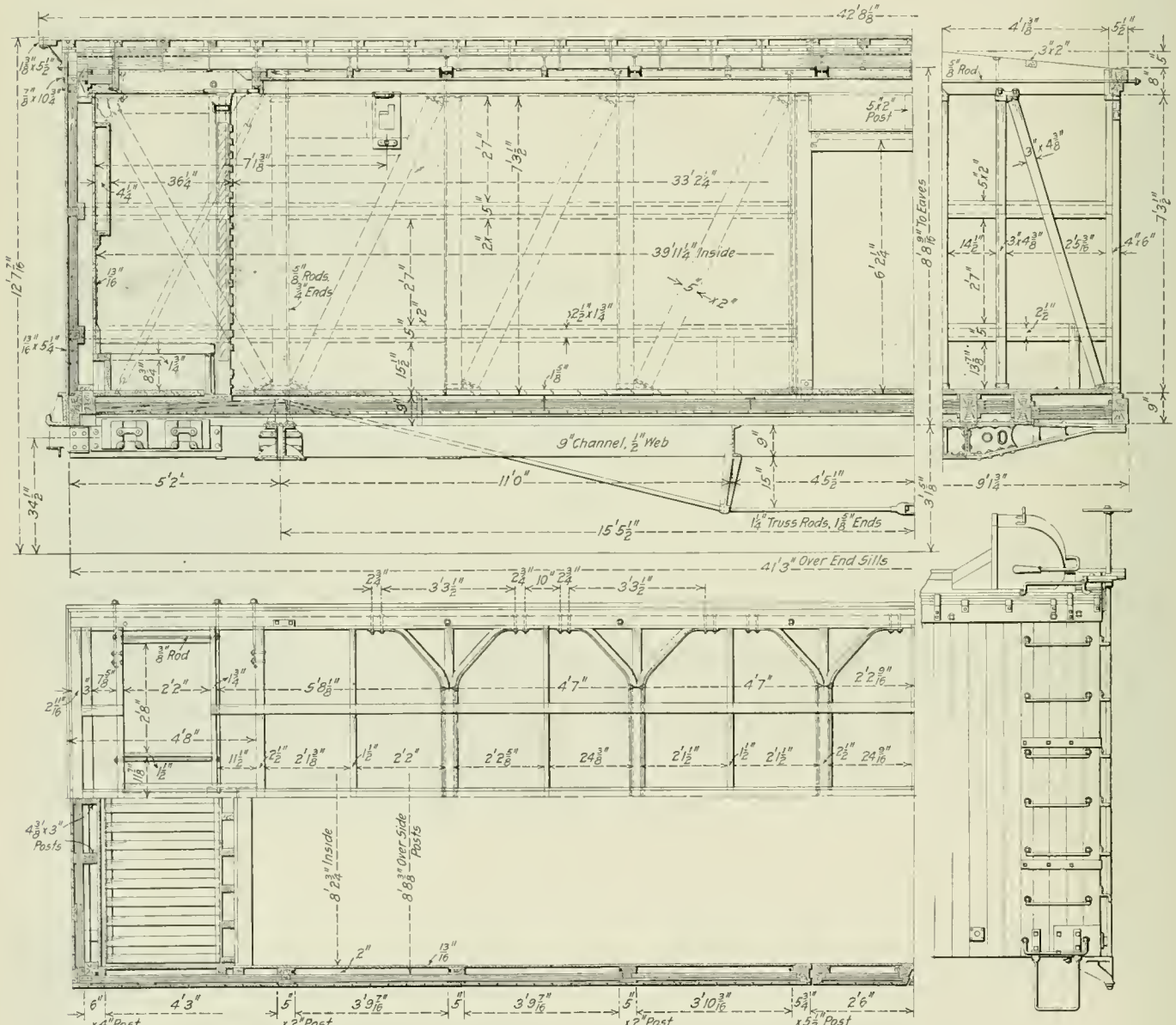

Plans and Elevations of the Santa Fe Refrigerator Car

exposed surfaces of the outside and inside layers is covered with three-ply waterproofing paper. The outside layer of Flaxlinum extends in continuous pieces from the side sill to the side plate; the other three are intercepted by the belt rail liners. The side plate is gained out to receive all four layers. The application at the ends is similar to that of the

three layers pass between the hatches and the third carline, between the third and the middle carlines, from each end, and between the purlins. This insulation is placed directly on the false ceiling, which is about 4 in. above the ceiling. There is an air space of 3/4 in. between the insulation and the roof boards. The floor is insulated with four layers of

1½-in. Flaxinum cellular blocks supported by a sub-floor. These layers are separated by blocks of ¾-in. Flaxinum.

On account of the sudden changes in temperature encountered by the cars coming from the western coast, it is

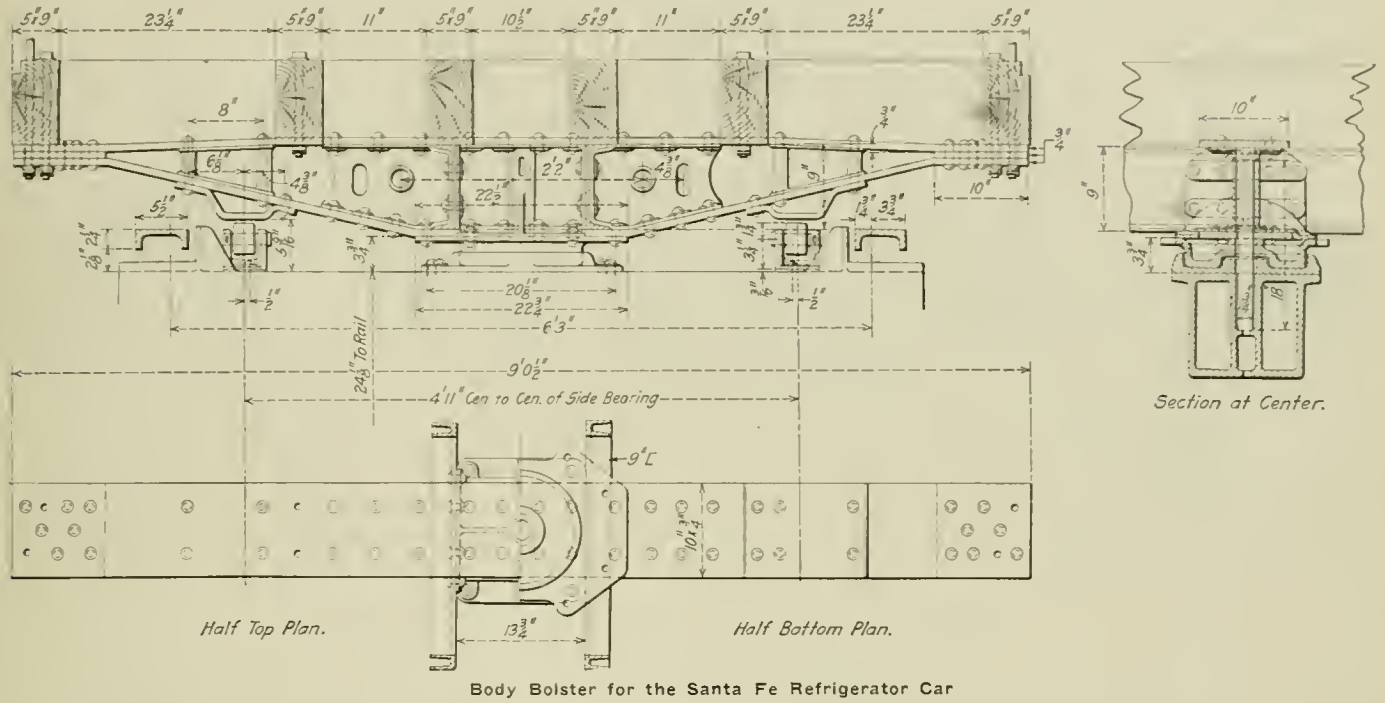

The insulation extends between the longitudinal sills of the car, and is entirely enclosed in waterproof material.

necessary frequently to open and close the hatches when carrying a load under ventilation. To do this expediently

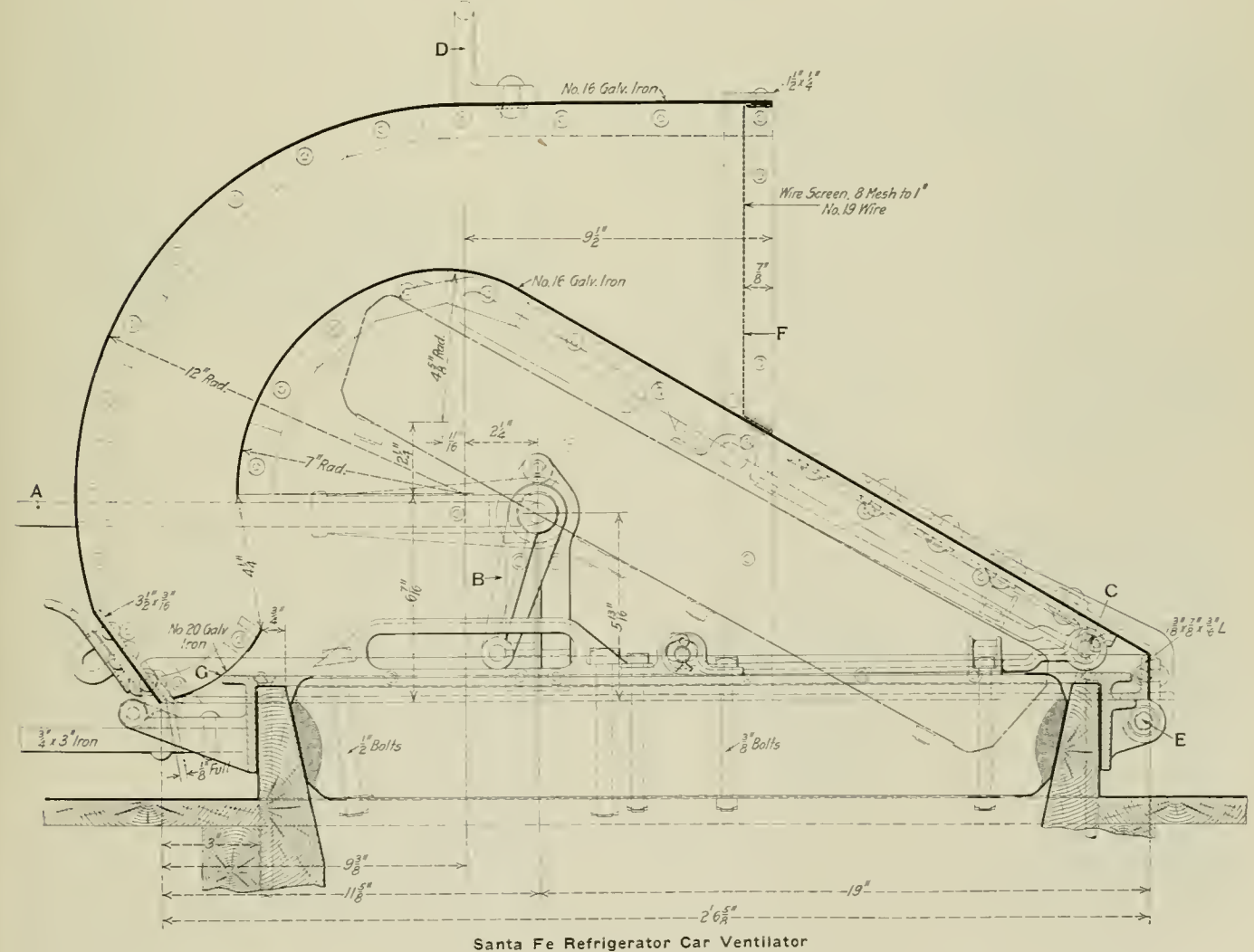

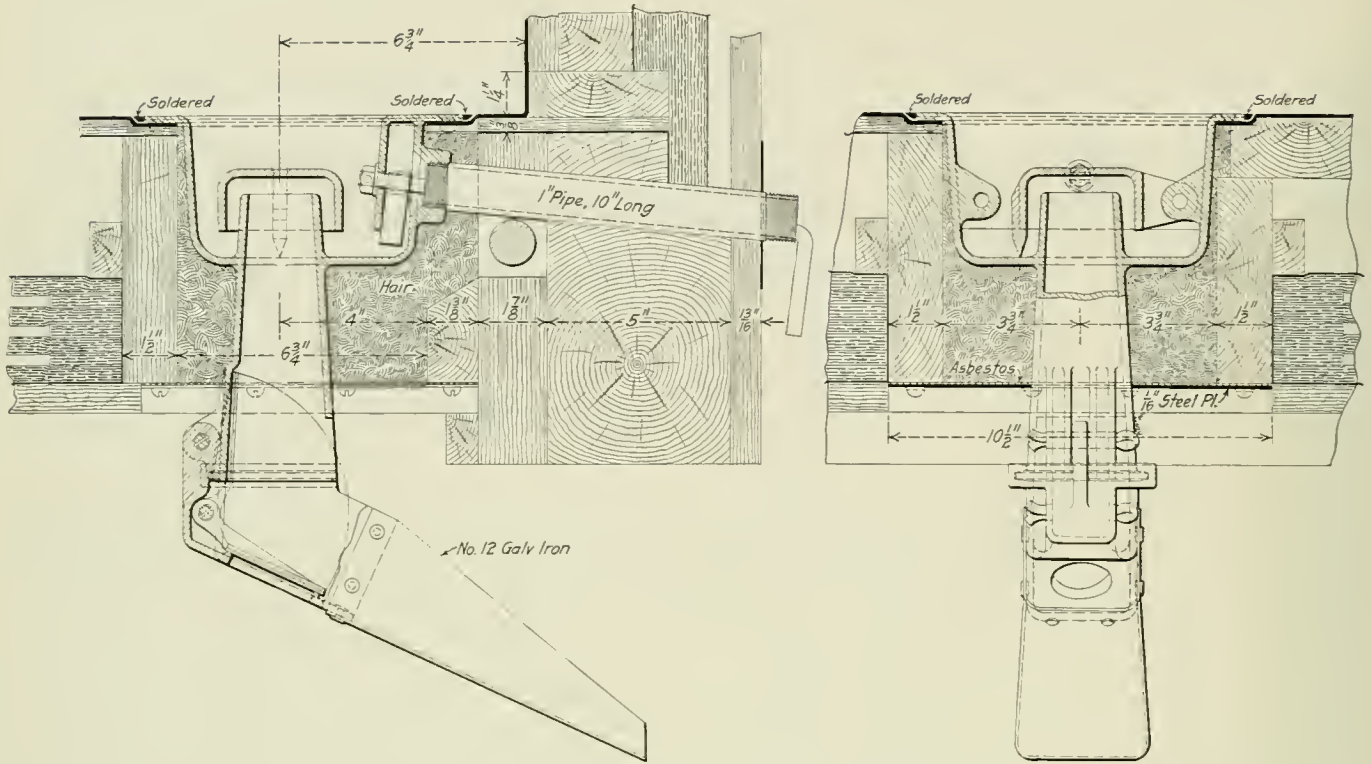

Malleable Iron Double Trap and Drain; Santa Fe Refrigerator Car

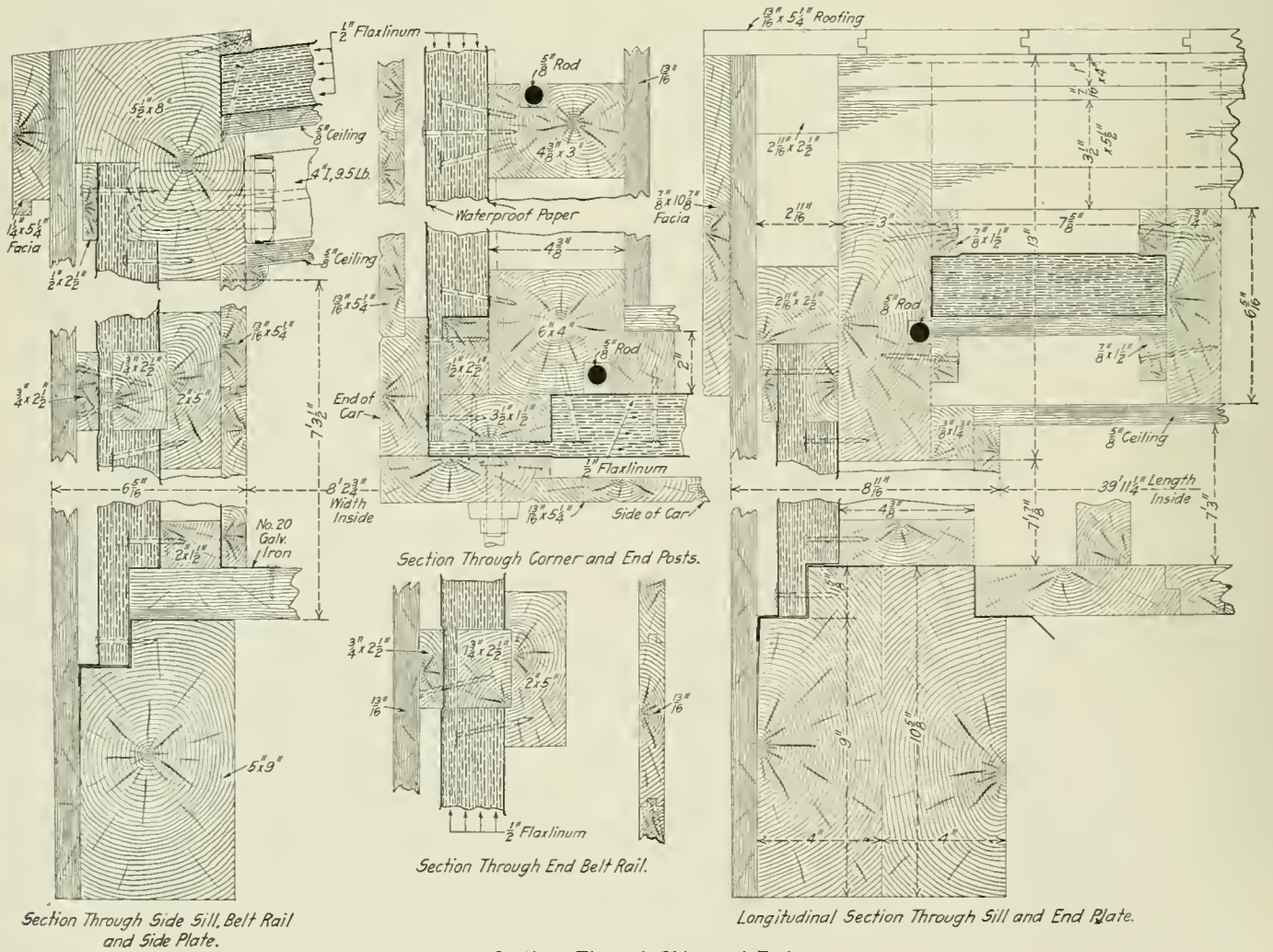

Sections Through Sides and Ends

the arrangement shown in one of the drawings has been devised by the engineer of car construction. The rod *A*, outside of the ventilator casing, operates the lever *B*, which, as the rod *A* is moved through 180 deg., raises the hatch to

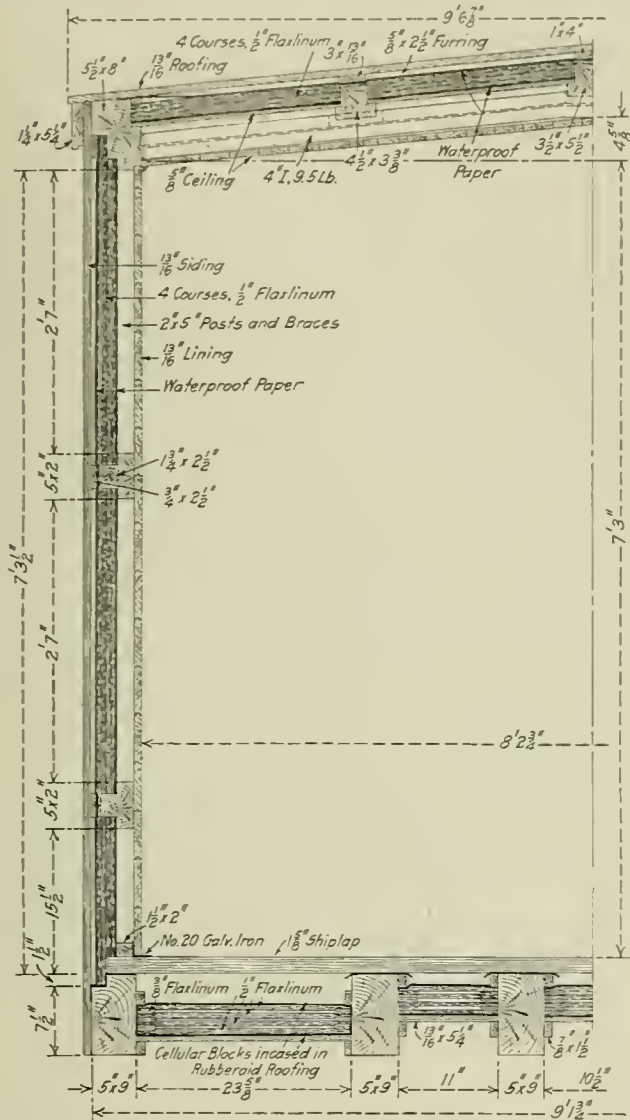

Half-Section of the Santa Fe Refrigerator Car

the open position shown by the dotted lines. The hatch is hinged at *C*, which is attached to the casing of the ventilator. When it is desired to ice the car the whole ventilator is raised by the handle *D* about the hinge *E*, the hatch lifting with

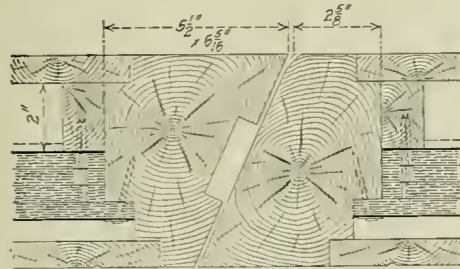

Section Through Beveled Door Stiles.

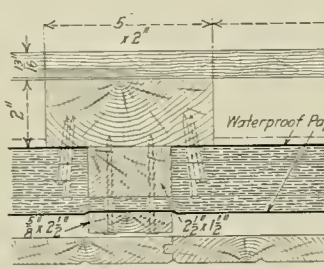

Section Through Door Stiles, Door Post and Side Post

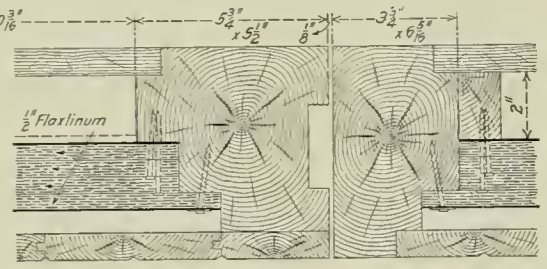

Section Through Door Stile, Door Post and Side Post.

the ventilator casing. A wire screen *F* is provided at the opening of the ventilators, and a deflector *G* is added to catch any dirt and water that passes through the screen, permitting it to pass through an opening at the bottom of the deflector. The hatchway is substantially reinforced by a mal-

leable iron frame cast in four pieces and joined at the corners, which contains the hinge for the ventilator. Each car is equipped with four of these ventilators, one at each corner.

The traps and drains in the ice boxes are of special interest. In addition to the inverted cup drain, a 1-in. pipe runs from the drain basin to the outside of the car, the drawings clearly showing this arrangement. The opening of the pipe drain is above the edge of the inverted cup, and the pipe itself is water sealed by the rib in the drain basin, the car thus always being water sealed. The purpose of this pipe is to carry the drain water well outside the track; as will be noted, the water will flow from the pipe before it will flow through the regular drain. The rod passing through this pipe, with the arm on the end, is placed there to permit the dislodging of any obstruction that may form at the opening of the pipe. The inverted cup is so built that it will fall by gravity to the closed position whenever raised. The space surrounding the cup is completely filled with hair insulation.

Among the specialties used in the construction of these cars are the following: Miner friction draft gear, type A-19-B; Creco brake beams; Andrews cast steel truck side frames; Standard Car Truck Company's roller side bearings and lateral motion device; Bohn collapsible bulkheads, and the Standard Railway Equipment Company's outside flexible metal roof.

## FREIGHT CAR CONSTRUCTION MAINTENANCE AND ABUSE\*

BY C. J. WYMER

General Car Foreman, Belt Railway, Chicago

All departments of a railroad are more or less affected by the condition of freight cars, and it is our purpose to point out some of the undesirable effects as the result of improper construction, maintenance and abuse. There are several important features to keep in mind in designing new equipment in order to combine economy and efficiency in such a way as to utilize the money expended with the best possible result. It is desirable to use the minimum amount of material possible, without sacrificing efficiency, as an unnecessary pound of metal or foot of lumber here and there not only adds to the initial cost and subsequent maintenance, but adds to the cost of transporting the vehicle. Each pound of weight contributes its proportion to this expense in the way of fuel consumption, wear on locomotives, tracks, and the vehicle itself. When considered individually the result is comparatively small, but when several hundred pounds are multiplied by a great number of cars and again by several years of life, it assumes large dimensions. While this is an economy deserving of careful consideration, there is also danger in employing its use to the extent that it ceases to be an economy only so far as the initial cost is concerned, and proves a

burden of expense in future maintenance, accidents, delays, loss and damage to freight, etc., which more than offset the first advantage gained. Observation demonstrates that this

\*Abstract of paper presented at the January meeting of the Car Foremen's Association of Chicago.

condition not infrequently exists either from an overzealous desire to reduce initial cost or lack of definite knowledge of requirements.

Having indicated some of the features to be avoided, as well as some features which should be favored, the thought naturally arises, How can the problem best be solved? We believe the remedy lies in standardizing designs and construction as rapidly as consistent, with means of enforcing the use of these standards. Standardizing means the elimination of the one man's opinion, from which most of our trouble comes, and insures thorough investigation by the best talent. Standardizing has several valuable features, a most valuable one being a reduction in the amount of material required for repairs. Material stocks are now much larger than would be necessary except for the various designs of more or less equal merit, which, if converted into cash and expended for the purchase of live material and employment of labor for repairing cars, would have a far-reaching effect toward better maintenance. It may be argued that standardizing will throttle invention and improvement, but we cannot concur in this thought. We believe it would automatically insure an improvement in construction and would eliminate many ideas of questionable merit. There should be sufficient elasticity to permit the incorporation of improvements of sufficient merit to warrant such action, but alleged improvements which are weighed in the balance and found wanting should not be entitled to recognition.

Having considered some features of construction, we desire to discuss some of the advantages of a better maintenance of equipment. It cannot be consistently argued that cars should be maintained in perfect condition. Any attempt to do so would mean much loss in both material and labor through renewal of parts suitable for further service; it would also mean withdrawing cars from service when they should be used. There is a degree of efficiency in maintenance necessary to keep the car in a reasonably safe condition for handling, and for protection to the commodity handled, also to prolong the life of the car at a minimum cost of maintenance during its existence, which in the end means the maximum of service. It is a well-known fact that many cars are expected to perform the service originally intended for them, which are wholly unfit to meet the requirements, and should be withdrawn from service until placed in a safe and serviceable condition. I am of the opinion that there are several reasons which contribute to this condition. One is poor design, resulting in cars becoming disabled and inefficient long before ordinary usage should reduce them to this condition. Another is inadequate facilities to meet the requirements for repairs in districts where large numbers of cars are required, with the result that the demand forces into service cars which should have repairs. The facilities provided have not kept pace with the increased demand for service, neither in capacity nor in efficiency of methods. Overtaxed facilities and lack of labor-saving methods in many instances prevent needed repairs being made. The period of service performed by these cars is only of short duration, and they return again for repairs in worse condition than before, while, if suitable attention had been given in the first instance, the cost in the end would have been less and the service performed by the car would have been much greater. It is not infrequent to see new end sills and draft timbers applied to worn-out draft sills, and numerous other repairs made in a similar manner, which can only mean that the same performance must soon be repeated. Greater uniformity in construction would insure a larger output at less cost, as suitable material would be more readily available and workmen becoming familiar with similar constructions can perform the work with greater dispatch.

Periodically reducing and reorganizing forces prevents economical repairs. Each time a shop is organized for extensive repairs it means the introduction of a large percentage of new labor, which takes time to become efficient, and the

money thus expended would keep a well organized force of efficient help permanently employed, producing a larger volume of work. If of necessity the forces are to be larger at certain times than others, the greatest result to be obtained for the money expended can be accomplished by reducing the force at seasons of the year when weather conditions are most favorable; there is a considerable percentage of loss in labor when there is no protection from the elements during the winter season.

It is also a good business proposition to repair the cars and get them in serviceable condition when they are idle and not needed in service. Good, serviceable cars mean so much in reducing other expenses resulting from cars in poor condition that there seems to be no good reason why they should not be maintained in an efficient, serviceable condition. A load placed in a defective car most generally means delayed movement, added expense in transporting, claims for damage, and often dissatisfied customers. An accident resulting from a bad car often means damage and destruction to other good cars and delay to the entire traffic of the railroad.

Greater uniformity and efficiency in construction, proper maintenance of equipment at all times, and adequate facilities for making repairs means economical maintenance of equipment and tracks, reduction of claims, reduced operating expenses, fewer blasts of the wrecking whistle, increased average mileage per car, more efficient service and a better satisfied investor and public.

We desire to introduce a thought which may be considered a little foreign to the subject, but so closely related to it that to us it does not seem out of place, as it indicates a now large expense, which, in our opinion, could be greatly reduced, and the money diverted to better maintenance of old or the purchase of new equipment. We refer to that feature of the M. C. B. Rules making a distinction between owners and delivering line defects. There is a vast army of men employed by the railroads whose principal duty is to make records as a means of protection against so-called delivering line defects, and attach greater importance to a few sheathing boards slightly raked, that may not affect the service of the car, than they do to a worn wheel or numerous other defects, endangering the safety of the equipment, lading and human life. We lay no censure at the doors of the men who are performing this service, as we are constantly teaching them that it is almost a crime to overlook a defect involving a defect card, which often has a value of less than a dollar. Why not take a businesslike view of the situation and cease spending two dollars in an effort to save one. Do away with the delivering line defects, inspect for safety of operation and lading only; educate these men along the lines of endeavor which have a real value, and cease to follow illusions. A vast amount of this labor expense could be diverted to the purchase of material and repairing defects which are a menace to safety, instead of finding and making a record of a lot of immaterial defects at the expense of more important ones. The reduction in expense would continue down through the offices and result in saving a large labor and stationery expense there.

To those who sometimes advance the argument that penalties are necessary against the handling line to promote the proper care of equipment, we would say that, in our opinion, there is no relation between the thoughts; the employees misusing a car have no knowledge of these penalties and take no notice of the ownership as indicated by the initials on a car. They will damage a car owned by the railroad employing them as readily as they will one owned by a foreign line. They could hardly make this distinction if they desired, on account of the mixed manner of handling cars.

It is our belief that the railroads are spending more money annually in labor and stationery in protecting themselves against these defects than it would cost to make the repairs. This does not mean the use of the owners' car without just compensation; that can be handled more economically on a rental basis than by rental and defect rules combined.

# SHOP PRACTICE

## TAPER ATTACHMENT FOR TURRET LATHES

At the Dale street (St. Paul) shops of the Great Northern a taper attachment made in the shop has been applied to one of the Jones & Lawson turret lathes and has given good

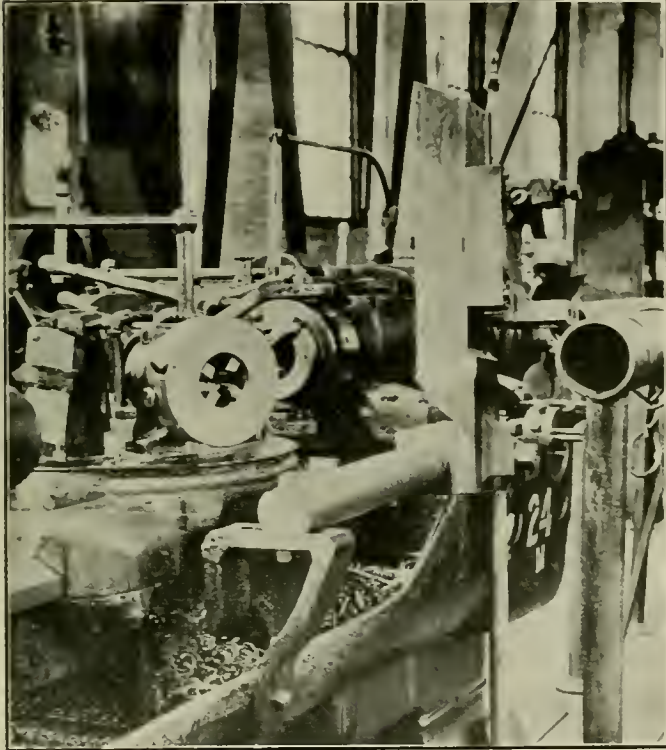

Rear View of Jones & Lamson Turret Lathe Showing the Taper Attachment

results. An adjustable guide bar is attached to substantial brackets on the back of the lathe, as shown in the illustrations,

the top surfaces of these brackets being planed parallel to the ways of the machine. Both ends of the guide bar are marked with gaging points directly below the center of the bar, which register on scales graduated to 1/32 in., laid off on both of the bracket supports. The distance between the gaging points on the bar is exactly 3 ft., and the slots in the supports, through which pass the bolts holding the guide bar, are cut to correspond to this diameter. On the guide bar slides the back support of an auxiliary carriage which carries the tool for

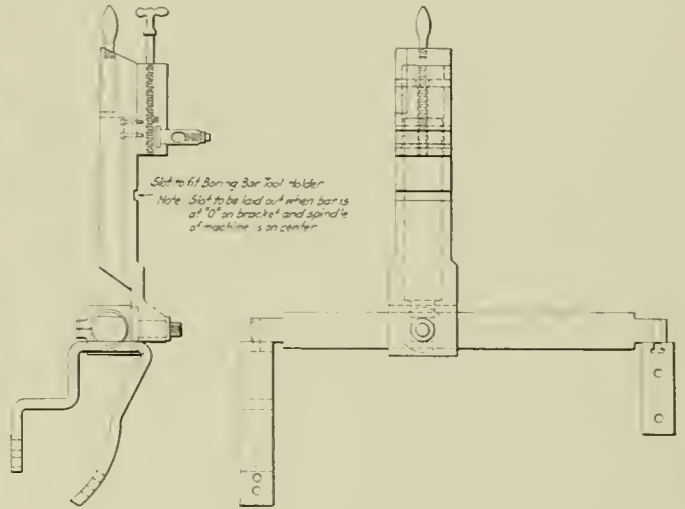

Turret Attachment for Jones & Lamson Turret Lathe

cutting the taper. This slide consists of a 4 1/8-in. by 6-in. block, which is split at the bottom and bored out to receive a 3/16-in. brass bushing. The auxiliary carriage is bolted direct to the block, being recessed to fit over a bearing on the block 4 in. in diameter and 9/16 in. high. This bearing is made large to provide a substantial anchorage for the carriage. The front end of the carriage rests in a slot planed out of the turret casting. This slot is of substantial dimen-

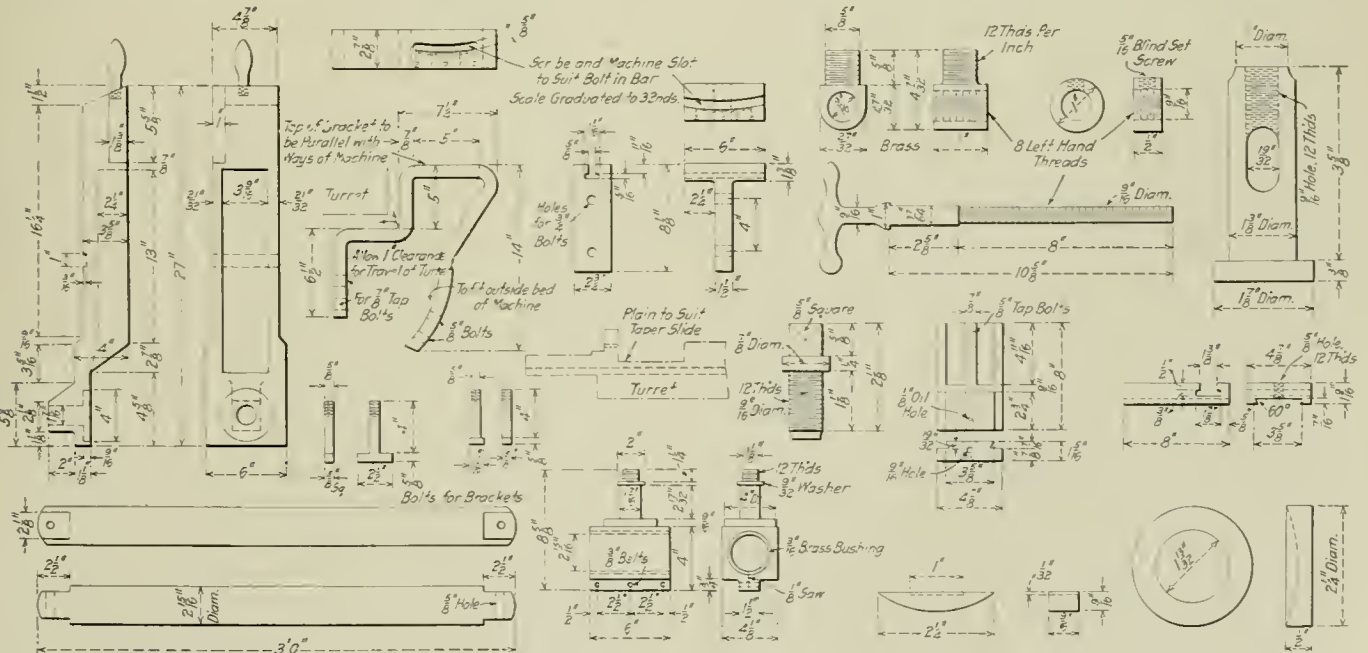

Details of the Taper Attachment for Turret Lathes

sion and by it only is the auxiliary tool carriage moved longitudinally. The auxiliary carriage itself is made from a bar 4 in. by 6 in., with a boss 2 in. high at the back end for receiving the bolt in the sliding block. The tool slide is of ordinary construction.

To cut a taper on the work the guide bar at the back is set at the taper desired, the auxiliary tool carriage is placed in the slot in the turret and the work fed out through the head of the machine to the proper distance, and the cuts taken with the tool on the auxiliary carriage. The adjustments are easily made and this attachment has been found very serviceable. When the taper attachment is not in use it is raised to a vertical position and rests on a bar or a support attached to the floor, as indicated in the photograph.

**NEVER SLIGHT A JOB\***

BY JOHN V. LeCOMPTE

Foreman, Mt. Claire Shops, Baltimore & Ohio, Baltimore, Md.

The old safety valve of the locomotive has given way to the pop. Guessing at the speed the train is making has been supplanted by the speed recorder. The carbon tool-steel of a few years ago has given way to high speed steel. On every hand evidences are noted of the supreme effort to attain the highest degree of efficiency.

The apprentice of today has a broader field of preparation than ever in the past; opportunities to attain to a responsible position are open to him. Schools of training are almost at his door, and to those who are in such humble circumstances that they are unable to attend, provision has been made, with instructions free of charge, that will better qualify them for the duties of today and give them an opportunity of acquiring knowledge that will more strongly fortify them for the future. In many of the larger railroad shops where the foreman is unable to give the time necessary to the proper instruction of the apprentice, able men have been appointed as apprentice instructors. These men give all their time to following up the work and instructing the boys as to the proper methods. While it is necessary that every apprentice receive a technical as well as a practical knowledge of the trade he seeks to master, yet personal contact at school and work, showing an interest in his advancement, instructing him as to any irregularity that may develop, will have much influence in the final results obtained.

At no time should an apprentice be led to believe that the task given him to perform is trivial, not demanding his best effort. At the shop school he should be taught that even in the smallest things care and attention should be given that they may be as near perfection as possible. The same holds good in the practical end (the shop). The drill press can be operated accurately and the best work obtained if care is exercised by the operator. The small lathes that are set apart for the first instructions can be operated to turn out good work and no task, no matter how menial, should be considered below any apprentice's dignity. Apprentices should never be instructed to slight any job given them. I believe thoroughly in the old adage as applied to apprentices—"Whatever is worth doing at all is worth doing well."

**ANTI-FRICTION BEARINGS FOR SHOP MOTORS**

The installation of anti-friction bearings in axle generators, car fans and headlight turbines has proved to be such a marked success that we believe the application of roller or ball bearings to shop motors would also prove to be desirable and advantageous. The induction motor, which is used more than any other type for shop purposes, has, in its small air-gap an inherent weakness which when the ordinary sleeve and ring-oiled bearings are used prevents it from being a

fool-proof machine. With the regular ring-oiled sleeve bearings this type of motor may run for months at a time exposed to sawdust, shavings, lime dust, coal dust, etc., without causing a fire and without any wear except at the bearings, because of the absence of a commutator and of other moving contacts, but unless carefully and periodically watched, and lubricated with the proper oil there is danger of the bearings wearing down to such an extent that the rotor will rub against the laminations of the stator, causing serious trouble.

For this reason it seems desirable to equip induction motors with anti-friction bearings and it is reasonable to expect that the results will be as satisfactory as they have been in the case of similar improvements in axle generators, fans and headlight turbines. In addition to minimizing the trouble resulting from the small air-gap there would be the additional advantage of decreasing the number of inspections required per year. This latter feature is of especial importance where the motors are located in places which are hard to reach, such as on the wall or on the roof truss, or on the top of a machine tool frame and other places where the motor is out of sight or difficult to reach and therefore liable to be forgotten or purposely avoided. Another source of trouble with ring-oiled bearings which could be eliminated by the use of anti-friction bearings, is that very often men who have charge of these motors, due to the lack of experience or perhaps because they cannot get the proper oil, sometimes use a heavy oil which prevents the rings from turning.—*Railway Electrical Engineer.*

**HOLDING DISTRIBUTING VALVES IN MAKING REPAIRS**

BY E. H. WOLF

The device shown in the illustration has been developed for use in a vise to act as a support for distributing valves when they are being repaired. The 3/8-in. pin rests on the top of the vise and the valve is bolted on. By loosening the

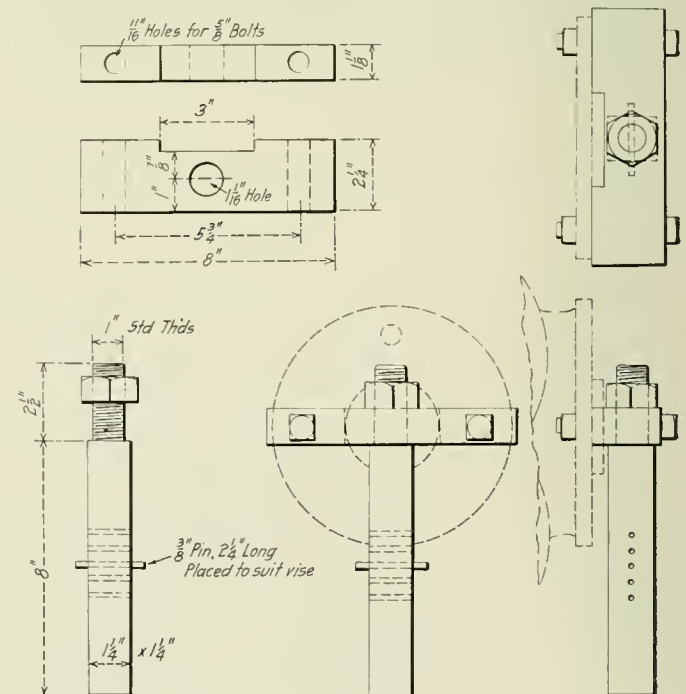

Arrangement for Holding Distributing Valve.

1-in. nut at the top, the valve can be swung around so as to obtain the best light and otherwise facilitate the work of the machinist on the valve seats and the packing rings. The device can be made of scrap material.

\*Entered in the competition on "How Can I Help the Apprentice?" which closed September 1, 1915.



# EFFICIENT ENGINEHOUSE ORGANIZATION

Prize Article in Competition Which Closed February 1 Takes Up Methods for Large Terminals

BY E. W. SMITH

The term organization is in many cases a misnomer when applied to the enginehouse. Very often the "enginehouse organization" consists of an individual in overalls who has to be a veritable jack-of-all trades, but who generally "delivers the goods." For that matter, regardless of how large the terminal operations may be or how well arranged is the force, the foreman still remains the chief factor to be considered. A poor foreman will soon disorganize the best organization, while a good foreman will usually make improvements.

In considering the organization of an enginehouse a distinction must be made between an organization for a small plant, handling under 60 engines in 24 hours, and a plant handling over 60 engines in 24 hours. For the smaller enginehouse a good foreman with a crew despatcher, a clerk, an assistant foreman at night, and one or two gang leaders, can handle the situation very well. For a plant handling over 60 engines it is necessary to make use of a well defined organization. The same organization will apply for an enginehouse handling, say 60 engines, as is necessary for an enginehouse handling 300 engines, the only difference being that for a small enginehouse only a skeleton organization is needed, to which must be added additional gangs or men as made necessary by the increased number of engines handled.

The efficient organization must be built up with the idea that the operation of an enginehouse should be similar to a machine, taking in engines from the road at one end and turning them out ready for the road at the other end. Poor gears must necessarily result in a slowing of the output and so long as the inbound engines continue coming, a congestion will result, the effects of which are far reaching. The vital thing to be considered is the reducing of the locomotive hours required in the enginehouse, which from the standpoint of the railroad represent money not earning interest and, in fact, actual losses in addition.

The measure of efficiency can easily be detected by the lapse of time from the arrival of locomotives at the inspection pits to the time that they are available, which should not exceed an average of four hours; and during intervals of power shortage at enginehouses handling a large number of engines, the average time should be reduced even below this figure. As a matter of fact, with the organization explained later the time has been reduced to 1 hr. 40 min. per engine handled.

Not only should the time from "arrival to ready" be closely followed, but the time from "ready to order" should be looked after and, if it is found that this time approximates more than two hours, arrangements should be made to either store engines or send them to the other end of the division. This of course applies to pooled power. During weather above freezing it has been found feasible to store engines at the enginehouse during a temporary power surplus by merely drawing the fire and draining the boiler. Locomotives so stored can be returned to service within three hours.

In discussing an enginehouse organization it is not believed necessary to show any plan or lay-out of tracks, for it is seldom that an ideal lay-out can be applied to the ground upon which the terminal facilities are to be constructed. The organization can always be fitted to the facilities, but the facilities cannot so easily be fitted to the organization.

In building a terminal, care should be taken to see that there is sufficient locomotive storage room between the inspec-

tion pits and the entering switch from the yards and that sufficient storage is allowed between the inspection pits and the ashpits, also between the ashpits and the enginehouse proper. Further, the storage sidings should have sufficient capacity for the holding of engines that require only light repairs, such as can be handled on tracks not located over pits, with possibly the exception of sponging or adjusting wedges. A sponging pit should be provided on the storage siding, if possible at the end of one of the storage tracks. A track should be provided adjacent to the ashpits upon which can be placed locomotives that have had the fire drawn for staybolt testing, repairs to grates, blowing and calking flues, and other defects which, while they require the drawing of the fire, can readily be attended to without making it necessary to place the locomotive in the enginehouse. A blower line should be laid along this track to facilitate the firing up.

If the enginehouse is not an integral part of a back shop, a machine and blacksmith shop should be provided. A small flange fire and facilities for safe-ending tubes will also save time and money. The advisability of providing such facilities may be questioned by some authorities, but with them and one or more electrically operated drop tables heavy repairs can be quickly and economically handled.

An enginehouse should be operated to keep engines in service, consequently, if an engine can, within say four days, be given a light class repair at the enginehouse, economy will result. It is not difficult to see that a saving can be made by handling the work in the enginehouse, rather than move the engine to the back shop, and have it await its turn for the erecting shop, even without considering the many small repairs which would be made when not really needed.

The organization outlined in the chart, and commented upon later, obtains at two enginehouses, the one handling on an average of 300 road and yard freight engines daily, located some distance from a back shop; the other an average of 140 passenger engines per day and in itself a part of a back shop. The organizations are almost exactly the same, other than the addition of repair gangs and additional miscellaneous forces and the operation of a small machine, blacksmith, and tube shop at the larger terminal.

The day foreman has charge of the entire operation, the night foreman performs the same duties, reporting to the day foreman. The first assistant foreman, in both the day and night organization, looks after the general operation, with special regard to the movement of engines through the terminal. As shown by the chart, his direct supervision is over the class of employees having to do with the work of general preparation of the locomotives.

The second assistant foremen, both day and night, are in charge of repairs as carried on in the enginehouse proper. The foremen, day and night, exercise general supervision over the plant.

Starting with the inspection pits, which the writer feels is the most important feature, if one is more important than another, we will follow the progress of the locomotive through the terminal.

## INSPECTION PITS

The gang leader in charge of the inspection pits should be a man thoroughly capable of deciding just what defects reported by the enginemen should be repaired and just what light repairs, such as tightening nuts, renewing brake shoes, etc., should be handled at the inspection pits without caus-

ing a congestion between the inspection pits and the yard switch.

The inspectors should be arranged in gangs, a gang to each pit, a machinery inspector on each side of the engine, one inspector under the engine and tender, an inspector to cover each side of the tender, a cab inspector, and one outside air-brake inspector. These inspectors should be instructed to report all defects which should, in their opinion, be repaired, with the exception of such light work as they can handle themselves. After the inspection, the gang leader should immediately go over the forms received from the inspectors and enginemen and report to the work distributors in the engine-house foreman's office the condition of the locomotive so that

ASHPITS

The ashpits should be in charge of a gang leader who will see that the engines are moved promptly from the inspection pit and that fires are promptly cleaned or drawn as the code marks indicate, the ashpits emptied at the proper times, and that no congestion or slowing up of the locomotive movement occurs around the ashpit. It has been found that the maximum results are obtained by having a hostler clean the fires, take water, sand, etc., and move the engine direct to its destination, either storage siding or house. A stationary gang in charge of a leader drops the ashpans, cleans the front end and ashpits and surroundings.

A gang leader or head hostler should be in charge of the

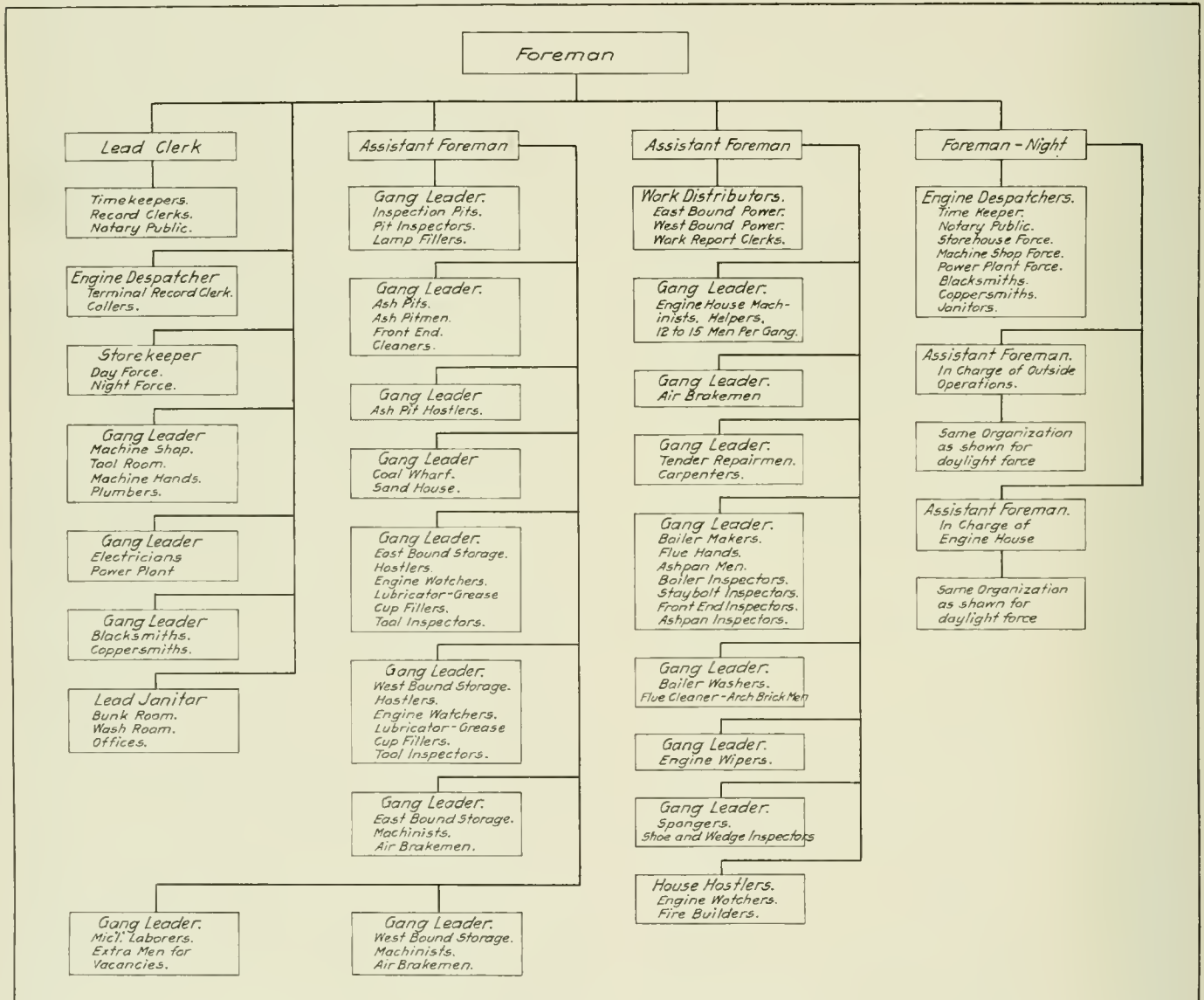

Organization Chart for a Large Enginehouse

the engine dispatcher can determine about what time the locomotive can be supplied for a train. The written report should then be transmitted to the foreman's office, preferably by means of an air tube. The fire door or the backhead of the engine should be chalked with a code number to show whether the fire is to be drawn or cleaned, and whether the locomotive is to go to the enginehouse for heavy repairs, to the siding for light repairs, or to the fire-up track adjacent to the ashpit with the fire drawn or cleaned. An important adjunct of the inspection pits is a sufficient supply of the most frequently used light material which can be applied by the inspectors. This material can be charged out and the value prorated on the basis of locomotives handled.

handling of locomotives on the storage siding and he should keep in close touch with the engine dispatcher, see that engines are promptly placed from the ashpits and that they are arranged in the proper order for leaving. He should also see that the crews report promptly and that the power is despatched in accordance with the leaving time as furnished by the engine dispatcher.

On the storage siding there should be a gang leader of machinists who will have charge of making repairs deemed necessary on locomotives despatched direct from the ashpits to the storage siding. He must be in a position to repair the emergency defects so often reported by enginemen just at leaving time. The inspectors' reports for locomotives sent to

the siding direct should be sent from the office through an air tube to the gang leader on the siding. A sponging pit should be provided on the siding, with spongers, in order to quickly handle this class of work.

There should be a gang leader in charge of the coal wharf and sand house, although at smaller terminals this work can usually be looked after by the leader on the ashpits.

OPERATION OF THE ENGINEHOUSE PROPER

Of the two assistant foremen, one should have charge of the repairs to locomotives and the operation of the enginehouse proper. In the organization shown above there are two work distributors, one for the Eastern division power and one for the Western division power, whose duties consist of turning over to the various gang leaders the reported defects

forms should then be taken by the work distributor to the respective gang leaders in charge of the repairs. In piece work shops, and if desired in day work shops, the work can of course be copied by clerks on work cards or other standard forms and the cards delivered to the gang leaders in lieu of the work report, which it may be desired to keep in the office.

It has been found that the best way to organize the repair gangs is to make use of a machinist pool leader, this man having with him an experienced helper and a less experienced man who is being developed into a machinist helper. The inexperienced man can be used for securing material and to assist in the handling of heavy parts. This pool arrangement divides the gang leader's force of 12 or 15 men into 4 or 5 sections, each section having a responsible leader who is

BLANK ENGINEHOUSE																
Track No.	Loco. No.	Time In House	Fire Out or In	Time Ordered	Machinist Work Gang No.			Air Brake Work	Tender Work	Sponger Gang	Boiler Work	Boiler Wash	Ready To Fire	Ready to Move Out	Time Out of House	Remarks
					1	2	3									
1																
2																
3																
4																
5																
6																

Blackboard for Keeping Track of the Progress of Locomotive Repairs

to be repaired, follow the progress of the repairs, and report to the engine despatcher the time that locomotives can be ordered for trains.

In order to keep in close touch at all times with the progress being made on repairs, a blackboard, arranged as shown in the engraving, should be provided in the enginehouse. The hostler bringing in an engine should enter the number and the time the engine arrived in the house, stating also whether the fire has been dumped or left in the firebox. This information should be placed in the line corresponding to the track number upon which the locomotive has been placed. The work distributor will place a symbol in the work columns indicating what gang leaders have been given work on the engine, and will also show the time ordered. When work has been completed the gang leader will erase the symbol X used to show that he was given work and mark

held strictly responsible for the repairs made by his pool. As the work is completed the original work cards or forms should be sent back to the gang leader and finally to the foreman's office for record and file.

In complying with the law effective January 1, 1916, it is felt that the gang leader actually "passing up" work should make proper notation on the original form and that these "passed up" items should be copied on a separate form and filed until the engine is held for boiler wash attention or heavy repairs. If it is not desired to make separate forms, the original forms should be consulted at times of heavy repairs. This of course necessitates filing these forms in a proper filing case by engine number.

The Interstate Commerce Commission requirements as to monthly and annual certification also make necessary a staff of boiler and machinery inspectors. These inspectors should

TERMINAL RECORD																										
MOVEMENTS OF LOCOMOTIVES AT _____ DIVISION															FROM MIDNIGHT TO MIDNIGHT _____ 191_____											
LOCOMOTIVES ARRIVING										LOCOMOTIVES DEPARTING																
Loco. No.	Division	Kind of Service	Train No.	Engineman	Fireman	Time Crew is Available	Arrived at Terminal	Time from Terminal to Pit Track	Arrived at Pit Track	Time from Pit Track to Engine House	Arrived at Engine House	Time from Arrival at Engine House Until Ready for Service	Time Ready for Service	Remarks	Train No.	Time Order Was Placed	Time Ordered for Service	Engineman	Fireman	Time Reported	Time Loco. Left Storage Track	Time Leaving Terminal With Train	Time from Arrival at Pit Track Until Ready for Service	Remarks		

Locomotive Terminal Record

O. K. The work distributor will mark O. K. for the fire, and O. K. to move out, and the outbound hostler will show the time that he departs with the engine.

The reports received in the foreman's office from the inspection pit should be of some convenient form complying with the Interstate Commerce Commission requirements. The work for the various gangs should be reported by the pit inspectors on separate blanks so that the boiler work will appear on one form, the machinist work on another, etc. These

be assigned specially to this work and the making out of the forms should be looked after by a clerk who, when possible, should be a notary.

ENGINE DESPATCHING.

The despatching of locomotives, assigning and calling of crews, and the checking of time tables, is in itself a very important part of the work and the engine despatcher should be a man of ability. This man should receive from the trans-

portation department the various requests for power, keep in touch with the power situation through the work distributors, see that the crew boards are properly kept up, that the crews are properly called, and when reporting see that they are given the proper time tables. He should also see that their time tables with general orders and stickers are in the proper condition. This man or his clerk should be required to keep a terminal sheet accounting for the entire period that the locomotives are at the terminal. This sheet should also show a record of the crews bringing in the engine and despatched with the engine. A suggested form is shown in one of the engravings; the columns "Arrival at terminal" and "Time leaving terminal with train" refer to the time the locomotive enters or leaves the switch from the road tracks to the main yard. The use of these columns would of course be optional, but they account for the time lost in the yard. This information, of course, must be telephoned to the enginehouse, if these columns are used. A glance at this sheet shows very quickly just how efficiently the terminal is being operated.

The storekeeper and his force form a department which can either make or break a terminal. How many times is an engine held for days awaiting some part, for example, a spring, which when received can be put in place within an hour and the engine made ready for service? The storekeeper should be preferably a mechanic and must be thoroughly familiar with his material and its use.

#### DISCIPLINE

In order to keep detentions arising from locomotive failures at a minimum and secure proper repairs, too much stress cannot be laid upon the proper disciplining of men. It should be remembered that inspectors are selected for their ability and that their value depends absolutely upon their judgment. Anyone is liable to err at times, but it is not best to impose discipline on inspectors, for they can always retaliate by "playing safe" and reporting numerous defects which in reality should not be reported, resulting in a great deal of work being "passed up" as unnecessary, with a certain amount very likely to be passed up that is necessary, once the habit is formed. On the other hand, if all items are repaired money and time will be wasted. If it is found that an inspector is continually failing, neglectful, or using faulty judgment, he should be removed rather than be continuously a subject for discipline. Insofar as the question of discipline generally is concerned, great care should be exercised by the foreman before imposing a penalty, for at best the enginehouse is no heaven to the man who must face its conditions day or night year after year.

The question of relief days has been found to have considerable influence on the amount of discipline imposed. When possible, a scheme should be in effect whereby each man will have at least one day off per week if he so desires. This does not necessarily mean that the man will be off on Sunday. In order to allow the force a regular relief day, it is of course necessary to provide a large number of extra men, this extra force being assigned for convenience to the gang leader of laborers. When a regular system of relief is applied there is a notable drop in the number of men absent due to sickness or with minor excuses.

Considering the elimination of detentions, a system should be followed whereby every passenger locomotive detention and, if possible, every freight detention is thoroughly investigated and brought to a conclusion, the information being furnished the master mechanic in charge and the enginehouse foreman who despatched the engine. Locomotive failures usually occur in epidemics due to some part being neglected. To eliminate the detentions the cause must be located and a remedy applied. Every failure has a cause; some of the causes may not be very evident, but they exist, and careful analysis will usually show them; the remedy is usually self evident.

The writer has endeavored to confine himself to the funda-

mentals, for a book could be written if all the various details were to be discussed. In conclusion it might be said that the statements in the article are not theoretical as the operations upon which they are based are in every-day use in two large enginehouses whose cost per engine handled and detentions per engine-mile are very conservative.

## WISE CHUCK FOR FILING PISTON RINGS

By R. J. HICKMAN

The device shown in the drawing has proved very convenient for use when filing packing rings to fit the grooves in the piston head. It consists of a wood table 2 ft. 5 in. square, to which are fitted four circular chuck jaws. The jaws are adjustable to accommodate rings from 16 in. to 26½ in. inside diameter, three of the jaws being permanently adjusted for each size of ring and the fourth provided with

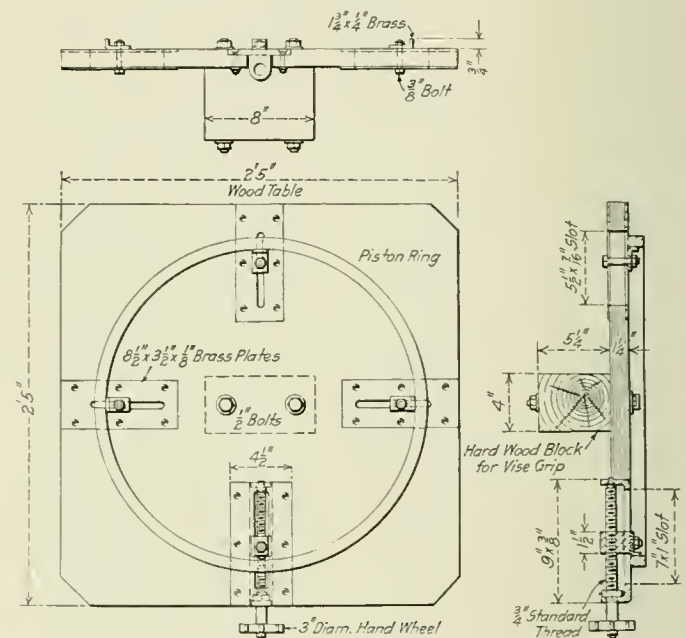

Piston Ring Chuck for Use in the Bench Vise

an adjusting screw, by means of which the ring is clamped in place.

To the under side of the table is bolted a wooden block 5¼ in. deep, 4 in. wide and 8 in. long. This block is of hard wood and is gripped in the bench vise. With the ring in place and the chuck clamped in the vise, the edge of the ring is exposed for filing throughout its circumference.

## A BROAD CONCEPTION OF APPRENTICESHIP\*

By V. T. KRQPIDLQWSKI

Chicago & Northwestern Shops, Winona, Minn.

A mature man should be put at the head of the apprentice department, one who is extremely liberal-minded, merciful and free from inclinations toward favoritism.

As to selecting new prospects and those for promotion, I do not believe in the highly-scientific doctrines of the psychologists, physiologists and craniologists; common-sense philosophy and good discretion are essential. A boy may have every sign of incorrigibility and the earmarks of a truant, yet if taken into confidence and intimate counsel, he may make the best man.

As to providing education, a good plan would be a combined system of understudies and correspondence courses. Every officer, clerk and trade should have understudies. The

\*Entered in the competition on "How Can I Help the Apprentice?" which closed September 1, 1915.

head of the bureau should see that *all* have understudies. The bureau should provide the curriculum for the correspondence courses and the understudy's immediate superior should act the teacher. For shop apprentices and other vocations, shop instructors may act as teachers. Additional instructions in shops should be carried on regularly each week along the line of studying materials and demonstrations in tools and machinery, etc.

Reports from immediate superiors should be required and followed up by representatives of the bureau to ascertain if true. Some idea of the progress students are making can be had from the correspondence courses, but natural characteristics can be learned only through personal intercourse, for which the bureau's representatives must make periodical searches. Individuals of exceptional ability should be picked and given special training. They should then be put through every phase of railroading until they reach their highest goal.

A system of apprenticeship ought to embrace all branches of railroading. Night study ought not be encouraged as a permanent thing. Railroads will benefit more through conserved vitality and good-will if instructions and studying can be done within the working day—ambitious individuals will resort to night work upon their own initiative.

### PUMP FOR TESTING BOILERS

The portable pump, shown in the accompanying illustration, is used at the Danville roundhouse of the Chicago & Eastern Illinois for washing out locomotive boilers. It consists of an old New York air compressor, which is operated by air from the shop lines. Air is admitted to the steam end and water to the air end of the pump, as indicated in the illustration, the air cylinder being bushed to whatever diameter is desired to give the required pressure. The air

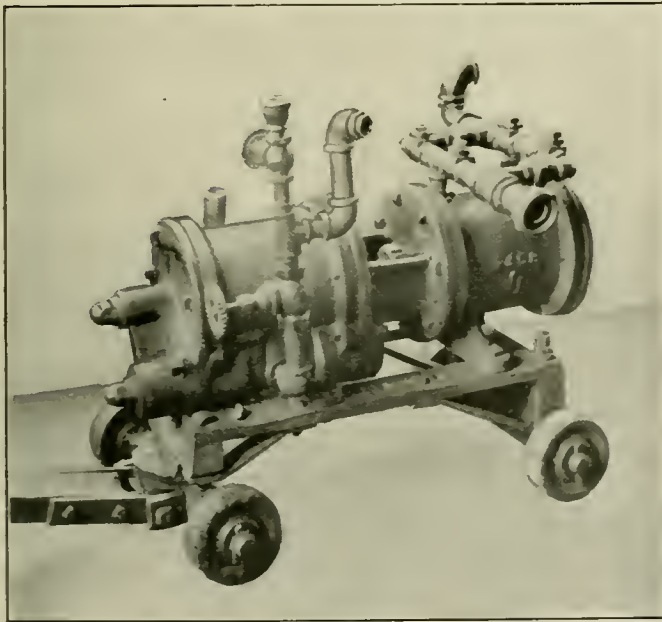

Boiler-Testing Pump

and water connections are clearly shown in the illustration, four check valves being provided to govern the proper distribution of the water between the ends of the cylinder. The outfit is mounted on a small four-wheeled truck for transportation to any part of the roundhouse.

**VISCOSITY OF LUBRICANTS.**—Viscosity tests, so called, do not necessarily prove anything of the lubricating quality of an oil, since rosin or other viscous oils may constitute a large proportion of the whole and yet have no lubricating value.—*Power.*

## RULES FOR THE SAFE HANDLING OF PAINTS AND OILS

BY J. W. GIBBONS

General Foreman, Locomotive Painters, Atchison, Topeka & Santa Fe., Topeka, Kans.

The danger involved in the handling of paints and oils can generally be attributed to ignorance of their nature. It is of importance that everyone having to do with materials of this kind should know how to handle them without risk of accident or injury to health. How to handle them will be best understood from a general knowledge of the characteristics of the different kinds of oils used in paints and varnishes. These oils belong to two general classes—volatile oils and vegetable oils. The various kinds of paints and varnishes contain oils of either one or both of these classes, which differ considerably from each other in their characteristics.

### VOLATILE OILS

Volatile oils are distillates from crude petroleum, coal tar, asphalt, grain, pine gum and wood products. The commonly used oils of this class are naphtha, gasoline, benzine, benzole, turpentine and alcohol. Coal oil, headlight oil and fuel oil are also of a more or less volatile nature and properly belong to this class.

There is no danger of spontaneous combustion from volatile oils, unless they are mixed with coal dust or other material which will generate heat. All volatile oils are, however, explosive, the danger from this source depending upon the degree of volatility. Care should be taken never to expose them to an open flame or a live spark, and in filling containers space should always be allowed for expansion and to make the proper allowance for this a knowledge of the highest temperature to which the oil will be subjected is necessary. These oils constantly throw off gas and in storing or transporting them the containers should be absolutely air tight. As a further precaution on large tanks a safety valve should be provided to release the accumulated gas should abnormal conditions of temperature arise. Should a leak occur in a container of volatile oil, repairs should never be attempted until the contents have been removed and the fumes thoroughly removed from the interior by filling the container with water or running air through it. Many men have been killed or injured in attempting to repair supposedly empty oil tanks or cans.

In using volatile oils for cleaning purposes, or varnish removers containing such materials, a bucket with a hinged lid should be used. A portable danger sign should also be placed where it may be seen by all who may come near. The containers should also be painted a distinctive color, red being preferred.

When a vessel containing volatile oils becomes ignited, no one should ever attempt to carry it from the building. More injuries occur and more large conflagrations are caused in this manner than by the explosion of the oil. In attempting to carry the container it is often upset, causing what would otherwise have been a small fire to spread rapidly to large proportions. All danger of explosion is past after the first flash, which is due to the ignition of the accumulated gas. When this gas is consumed the oil will burn evenly and if the flame does not endanger the surrounding property, the fire will often burn itself out with no other damage than the loss of the oil and possibly the container. If the container is equipped with a lid the fire may be readily extinguished by closing the lid, which smothers out the blaze. Fire extinguishers are also very effective in putting out oil fires. Water should never be used unless it can be thrown with sufficient force to completely smother the blaze. Otherwise, it will only result in spreading the fire. Sand may often be used effectively in controlling a fire of this kind.

One of the most dangerous methods of using volatile oils

is in the hand torch commonly employed by painters, tanners and electricians: Great care should be exercised to see that torches of this kind are in good condition and properly filled and that too much air is not pumped into the torch. Years ago a man working for the writer was burned to death by the explosion of one of these torches and in order to eliminate this danger the paint burning equipment shown in the drawing was developed. The distinctive feature of this outfit is the use of a Westinghouse slide valve feed valve to regulate the pressure on the oil tank.

But the danger of explosion and fire are not the only ones to which the users of volatile oils are exposed. There are others which, because of their insidious nature, are seldom guarded against. The United States Bureau of Labor has issued Bulletin No. 120 dealing with this phase of the subject. This bulletin is entitled "Hygiene of the Painter's Trade" and from it the information which follows has been taken:

Turpentine causes headaches, dizziness, dry throat, bronchitis and irritation of the urinary system.

The fumes of gasoline, naphtha and benzene will poison the system. If this poisoning becomes chronic it results in

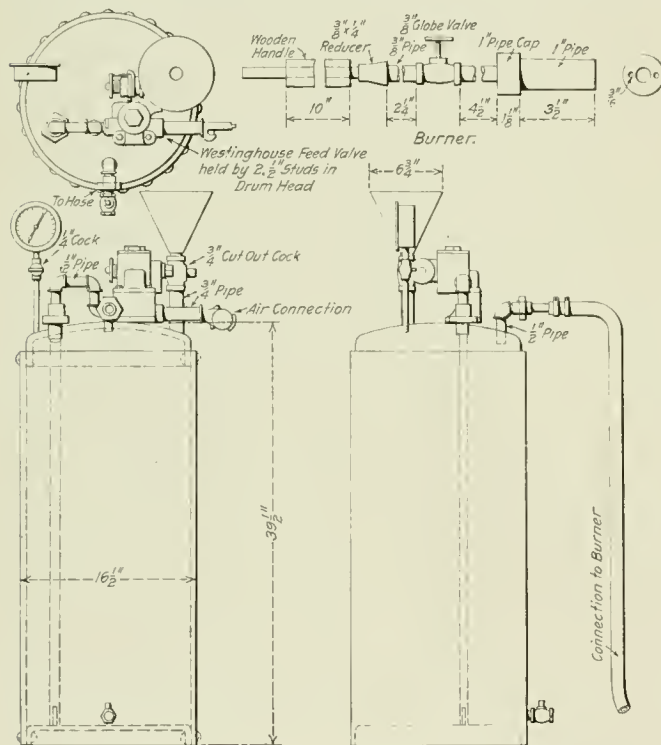

Oil Tank and Pressure Regulating Apparatus for Burning Off Paint

indigestion, bronchitis, loss of strength and even in impaired mentality.

The fumes of benzole, a large percentage of which is used in paint and varnish removers, may rapidly prove fatal. The symptoms are inflammation and ulceration of the gums and lips.

The fumes of amyl-acetate, which is used in varnish remover and in bronzing and gilding fluids, are narcotic, causing headaches, nausea, palpitation of the heart and difficult breathing.

Wood alcohol is sometimes used in cutting shellac and in paint and varnish removers. It is a dangerous poison, relative to the improper use of which the Committee on the Prevention of Blindness for the State of New York has the following to say: "As much blindness and death have been caused by breathing the fumes of wood alcohol as by swallowing the liquid."

Men using varnish and paint removers should be furnished with respirators and rubber gloves.

#### VEGETABLE OILS

Among the vegetable oils generally used in mixing and grinding paint are linseed, cotton seed, soy bean, China wood, sunflower and corn oils. These oils are not explosive except at very high temperature, but they are all more or less subject to spontaneous combustion, due to the heat generated by the oxidation of the oils. This danger is greatly increased when litharge, manganese or other oxidizing agencies are used with the oil. Linseed oil, the quickest drying vegetable oil, is more dangerous in this respect than the others. When used in cleaning or polishing, the rags or waste with which the oil is applied should always be gathered up and burned.

Most paints contain either vegetable or mineral oil, while some contain both. Varnish is made up of vegetable oils and gums reduced with naphtha. Paints and varnishes are therefore either explosive or subject to spontaneous combustion. It is evident that they should be stored in a clean room as fireproof as conditions will permit, and whether in storage or in transit if a leakage is discovered, prompt steps should be taken to avoid the danger of fire or explosion. It is not alone through leakage that dangers may arise, but frequently the barrels or containers which have been set aside as empty, contain enough oil to start a fire or cause an explosion. Care should be taken to see that all residue is removed before empty barrels are stored or cans are sent to the shop for repairs.

The danger from the handling of lead and Paris green pigments are not great with the modern methods of painting railway equipment, as they are but seldom used. In sand-papery, however, men so employed either should be protected with respirators or should work in a well-ventilated room.

The precautions necessary to the protection of health and property in handling paints and oils may be summed up in the following list of "Don'ts":

Don't use varnish remover or volatile oil in an ill-ventilated room unless you are properly protected from the fumes.

Don't use them anywhere unless you have a danger sign. Don't smoke or carry an open light in a room where they are used or stored.

Don't keep open a can or bucket of volatile material when not in use.

Don't use wood alcohol for any purpose when a substitute, such as denatured alcohol, can be secured.

Don't leave waste or rags containing oil or grease in the shop over night.

Don't store your dinner bucket in a room where paints or oils are stored.

Don't fail to wash before eating.

Don't eat in an ill-ventilated room containing paints or oils.

**SPECIAL LUBRICANTS FOR LIGHT MACHINERY.**—Special mixtures of oil are necessary in some cases, but for light machinery using only small quantities, a mixture of 80 per cent light mineral and 20 per cent sperm is good and should not cost more than 30c. per gallon. It will not, however, stand heavy bearing pressure or form a film at slow speed. Its film thickness on metal is about 0.0002 in.—*Power.*

**TEST FOR LUBRICANTS.**—A simple experiment in order to find out if a lubricant contains corroding substances is to cover a steel surface with the lubricant and expose it to the sunlight for about two or three weeks. If the lubricant contains acid the steel surface will show etchings, while water will oxidize the steel and the surface will show rust pits. This experiment should be made with a highly polished surface and a roughly ground surface as the effect of the acid shows up best on a polished surface, while the rusting can be observed better on a rough surface.—*Graphite.*

# CHESAPEAKE & OHIO SCRAP RECLAMATION

Savings Effected at the Huntington, W. Va., Shops;  
Special Buildings and Machinery Are Employed

BY H. M. BROWN

Shop Superintendent, Chesapeake & Ohio, Huntington, W. Va.

During the past three or four years no one item has received greater care or attention on the Chesapeake & Ohio than the reclamation of scrap, the officers realizing that a vast amount of slightly worn material requiring but a small expenditure to put again in service, finds its way to the scrap bins. The saving effected by reclamation has caused this class of work to be more appreciated.

Special tools and equipment have been installed, some of



Equipment for Reclaiming Nuts

which we have manufactured ourselves, designed to accomplish as economically as possible the various operations necessary to put the materials in practically new condition. However, the cost of reclamation is not carried to such an extreme that it would have been best to consign the material to the scrap dealer and purchase new stock, for I believe

in an operation of this kind must necessarily be felt in the results that are obtained as a whole.

We handle at our Huntington shops practically all the scrap from the entire system. As these shops are located in the center of the system, it is a convenient point for handling work of this nature, and while we do not have what might be termed a central scrap dock operated under a separate and distinct organization, we have, on the other hand, been working along lines which it is believed are best suited to our conditions and will result in the greatest economy. Other shops along the line have become interested and instead of the railway company being burdened with the expense of having a separate organization, we find interest manifested at each terminal in seeing that nothing is wasted that could be used to good advantage. In this way considerable additional expense is saved on the reclamation of various articles by eliminating the labor of handling at the terminals. The freight from the various terminals to the central shop, the unloading and handling after arrival and the final reshipment must all be considered, and I believe these items are overlooked in a great many instances when calculating the final cost.

When the cars of scrap arrive at Huntington, they are unloaded on a special platform into wagons where the scrap is sorted by gangs under the supervision of a foreman who is capable of passing on it. All the larger and heavier material is handled by two yard cranes, one of which is equipped with a magnet. After the scrap is sorted, that which is to be sold is loaded directly into cars which are consigned to the scrap dealers, thereby saving an additional handling which would be involved if we were to place the scrap in bins and then later transfer it from the bins to the scrap cars.

We watch the various items reclaimed to see that we are

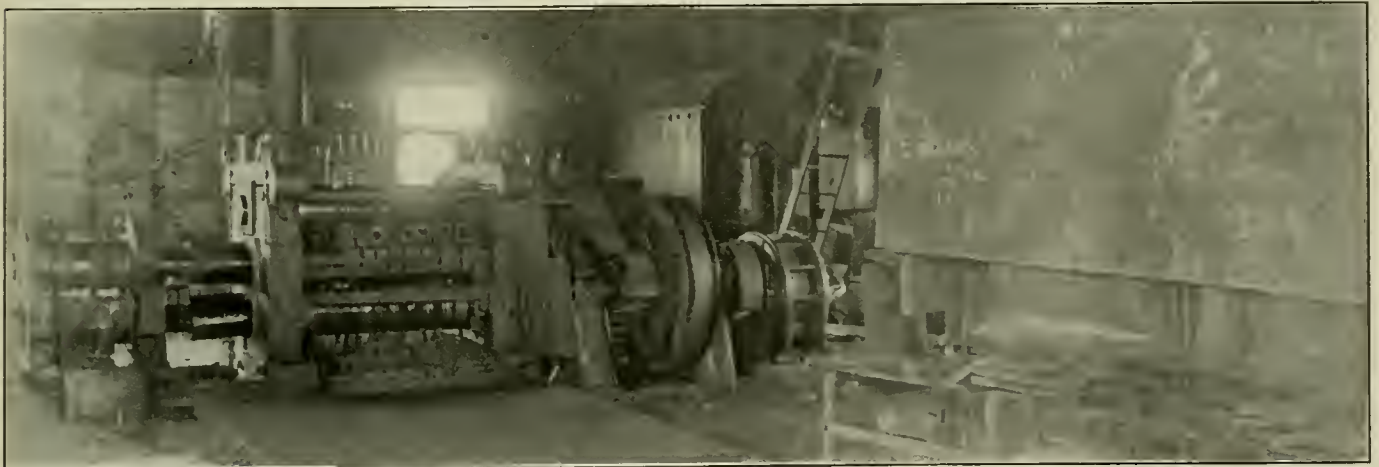

Rolling Mill at the Huntington Shops

that in a great many instances the work of reclamation can be overdone.

The buildings that are termed "scrap shops" are made from scrap, all of the lumber used being that removed from cars undergoing repairs and the covering being old car roofing. The buildings are kept nicely painted and a fairly successful attempt has been made to keep them and their surroundings in a neat and orderly condition. The moral effect

not overdoing the work and putting back into service material that will possibly fail and cause trouble, in which case the labor of application would be lost. To guard against this the articles reclaimed are carefully inspected.

## BOLTS AND NUTS

All scrap bolts are sent to the blacksmith shop where the ends are sheared off if bad and the bolts rethreaded. There

is provided a single and double head bolt machine that does practically nothing else but this class of work. The bolts are then boxed by sizes and are ready for reapplication. We reclaim on an average of 200,000 bolts per month.

The scrap nuts are collected, annealed and rattled, and are then sent to the sorting room in which is located a long table to enable them to be sorted quickly and placed in bins. There are located in the same building two seven-spindle nut-tapping machines which are in close proximity to the bins, so that the nuts after being sorted can be easily and quickly handled to the tapping machines, and from the machines into kegs ready for use. All of this work is handled on a piece-work basis. We reclaim 125 kegs of nuts per month.

There is also located in this building a large alligator shear which is used to shear up rods into bolt lengths if the iron is in good condition. These bolts are then sent to the blacksmith shop, headed and threaded. This shear is also used to cut heavy wrought iron bars into lengths suitable for the furnaces at the rolling mill.

#### ROLLING MILL

All iron that cannot be used in its present shape (for example, old arch bars are used for step brackets for switching engines, the filling pieces removed from composite bolsters

case may be, and returned to service. There were 4,800 heads saved thus during 1915.

#### BLACKSMITH SHOP

No one department has afforded a better opportunity to effect a reclamation than the blacksmith shop, and parts that are bent or broken can be straightened or welded at a nominal cost. Track tools of all kinds, such as adzes, spike mauls, long bars and claw bars are straightened, redressed

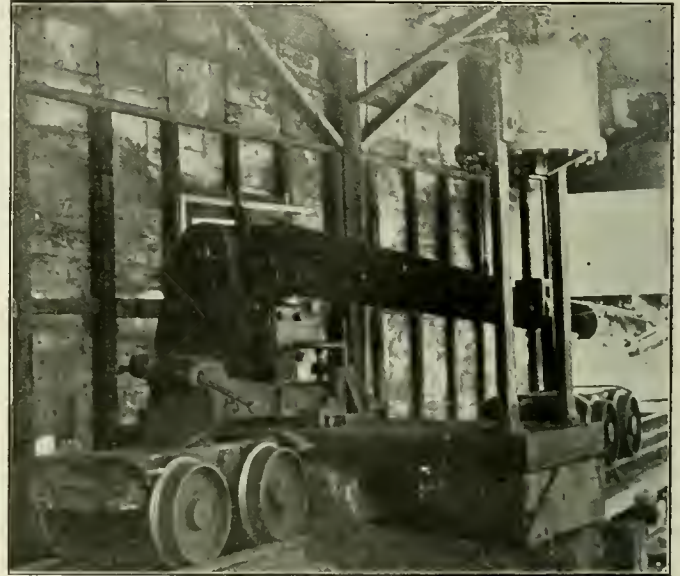

Machine for Removing Coupler Yokes

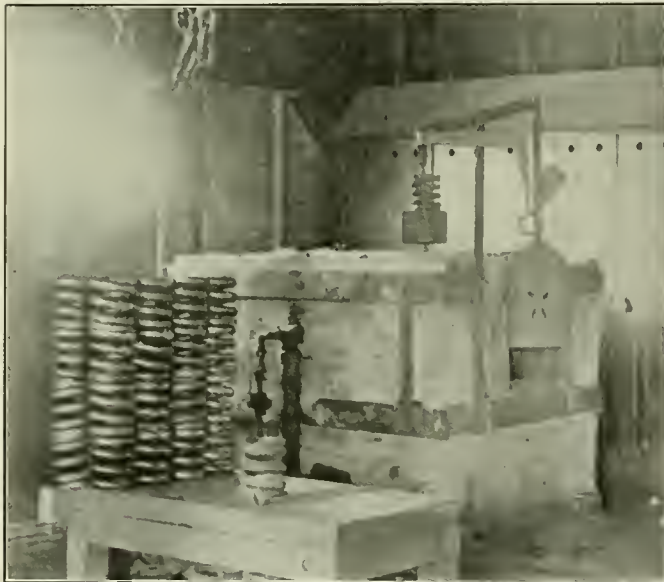

Furnace for Reclaiming Coil Springs

are used for re-enforcing steel center sills) or which would not be too expensive to forge to size to enter the rolls, is sent to the rolling mill. This is in a separate building, constructed from scrap material. There is a large furnace and a motor-driven set of Ajax reclaiming rolls. There are rolled approximately 1,000 tons per year, and at present prices of iron and steel, quite a saving is effected. Average saving, after deducting cost of scrap, labor, maintenance, fuel and supervision, amounts to \$1,100 per month.

#### SPRINGS AND COUPLERS

Located in the rolling mill building is a coil spring reclaiming plant, the furnace being constructed from scrap arch brick and firebrick broken in transit. The springs are sorted, heated and the coils separated to give proper height; they are then tempered and tested and are again ready for service. From 100 to 125 springs are reclaimed per day.

Steel couplers with the stems bent, eyes pulled out, guard arms bent or otherwise damaged are sorted and sent to a specially constructed shed, where the yokes are stripped from them by a special machine, shown in one of the illustrations. The couplers are then sent to the blacksmith shop where they are electrically welded, if necessary, or straightened as the

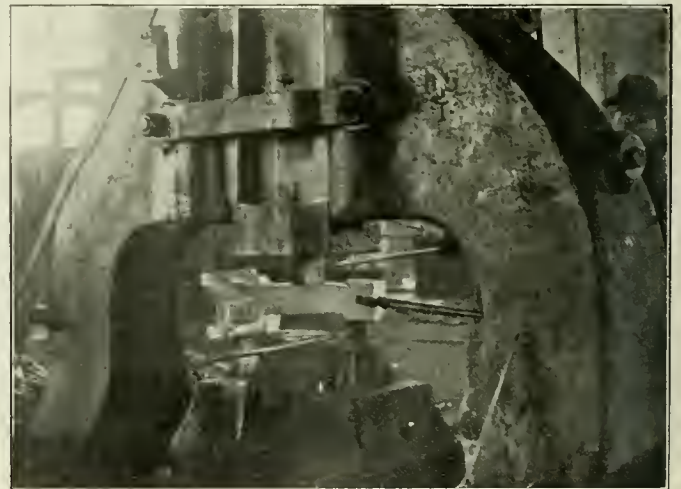

Straightening a Drawbar

sheets of steel cars of old sheets removed from steel cars that have certain portions good for further use. This has not only increased the output but has reduced the cost of car maintenance. The saving effected by making repairs in this manner, instead of applying new side and floor sheets, amounts to approximately \$4,000 per month. Old locomotive tires are used for the manufacture of guides, and on account of the



excessive cost of tool steel for dies, we are now using dies in the bolt and rivet forging machines that are manufactured from tire steel. These dies are giving excellent results.

**MAINTENANCE OF WAY MATERIAL**

Parts of switch stands, cuffs from switch points, and rods are sorted and re-assembled. We have a separate building for this work where all work of this nature is handled. All the stands are carefully inspected and worn out or broken parts,

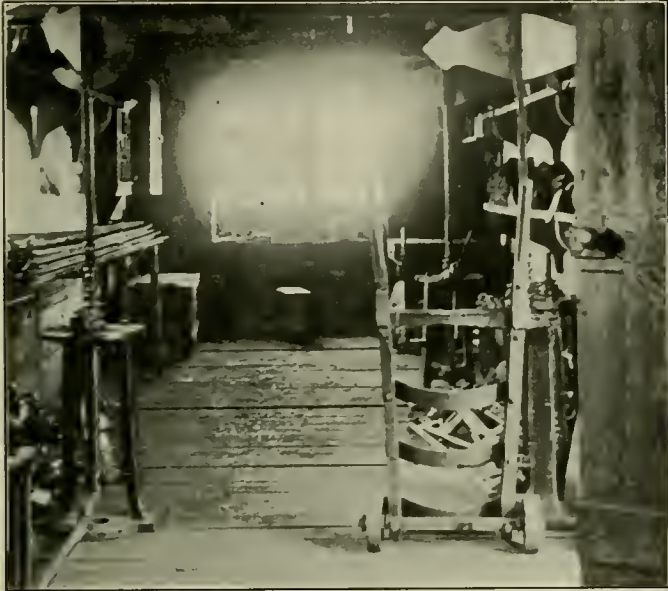

Switch Stand Repair Shop

if they cannot be repaired by the electric welder or in the blacksmith shop, are renewed. Stands and rods when complete are shipped wherever needed on the system. Broken frogs are repaired, parts being furnished by the manufacturers. We do not have a frog or switch shop to handle this work.

All hand and motor cars, as well as baggage wagons, track drills, jacks, levels and station skids are repaired, either removing and replacing the parts damaged or taking two or



Shop for Repairing and Reclaiming Car and Track Jacks

three of the same articles and making one good article from the undamaged parts. Approximately \$2,000 per month is saved in this manner.

We have a special shop for the handling of all jacks and we reclaim approximately from 50 to 60 jacks per month and effect a saving of from \$200 to \$250.

**BRAKEBEAMS**

On account of accessibility, and at the same time to overcome the danger from flying rivets, the brakebeam shop is segregated from the other buildings and is especially constructed to handle this particular phase of the work. The beams are stripped of broken or bent parts, using a special rivet buster for the work of cutting off the rivets, and the beam, if bent, is then passed into the furnace where it is heated, and removed from the opposite side to a surface plate, where it is straightened. It is then passed to the assembling bench where new parts are applied. The truss rods for these beams are rerolled scrap and the nuts those which have been retapped. We have reclaimed over 1,900 beams in one month with a saving of over \$1.00 per beam, the labor cost being 15 cents per beam. We have not found it necessary to get a single new brakebeam from the storeroom in the past two years, enough being saved by reclamation to care for the cars repaired that require brakebeam renewal. This is quite an item when it is considered that we repaired 41,209 light, heavy and rebuilt cars in 1914.

**BRASS FOUNDRY SCRAP**

No one item of scrap receives closer attention than the brass. In the case of every broken fitting that has brass parts, the brass portion is removed, as well as all copper wire that cannot be used for joints on glands, etc. All of the old

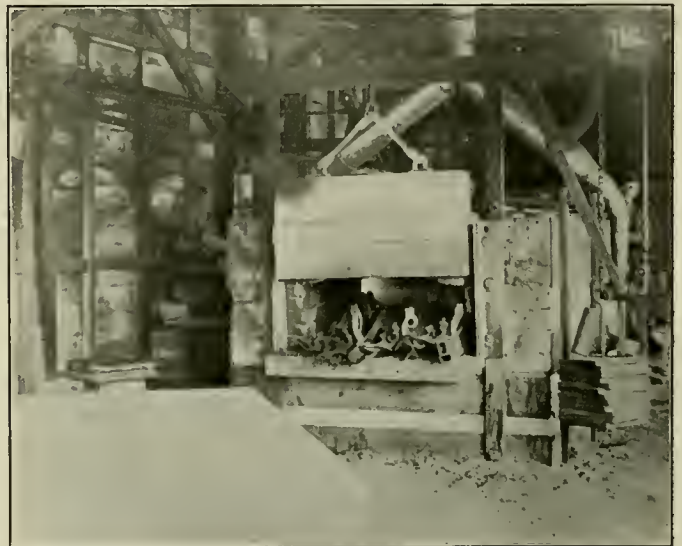

Furnace and Surface Plate for Straightening Brakebeams

electric wire has the insulation removed and the copper melted. Old lead plates from storage batteries are melted, impurities removed, and the lead cast into ingots, using the proper proportion of other metals to meet specifications. This is used for lining car bearings and crossheads and for any purpose requiring a good bearing metal. The brass is stored in bins and the bronze is carefully housed.

**AIR BRAKE APPLIANCES**

In the building for the reclamation of jacks is also located equipment for repairing and mounting air hose. Fittings are stripped from the old hose on a home-made machine, cleaned and reapplied. Over 90 per cent of the fittings are returned to service. The air hose that have a certain portion good are used to make dummy hose connections, but one of the best savings effected is the use of the old air hose as a holder for the cutters used in the steel car yard. The expense of manufacturing cutters with an eye in the head, and supplying wooden handles, when the use and abuse that these tools receive is considered, makes the cost of maintenance excessive; but by making a 1¾-in. chisel 10 in. long and driv-

ing it through an old air hose, a satisfactory cutter is obtained. In addition to the amount saved in eliminating handle breakages and in the manufacture of the cutters there is no danger of injuries due to the missing of the cutter and striking the handle. All steam hose are stripped and remounted in this department, all of this work being handled on a piece-work basis. In another section air brake cylinders and reservoirs are reclaimed, as well as retaining valves that find their way to the scrap bins. Parts that are broken are removed and the good parts are collected and reassembled.

The angle cock grinding machine is located in another building. Twelve cylinders can be ground simultaneously with this machine. We are able to make repairs to all angle cocks that are sent in for repairs or those that arrive with the scrap.

Triple valves are cared for in the pipe and copper shop where we have a complete test rack, and the valves after being repaired undergo a very rigid test. The same method is pursued in this department as in the others, that of discarding broken pieces and saving the good parts in order to build up a complete article.

#### LAGGING, ETC.

Old boiler lagging that is removed is sent to a building where it is ground up and remoulded. Quite a saving is effected in this manner at a nominal cost.

Scrap car roofing plays an important part in the scrap yard, the buildings being constructed of it. Wash buckets are manufactured for the shops as well as for the locomotives; also wash basins for caboose cars, fire buckets, swab casings for piston rods and valve stems, stove pipe, oil cans, gutters for shop buildings, etc.

A large number of switch and hand lanterns are reclaimed each month, as well as gage lamps, classification and marker lamps, by simply boiling in a vat, renewing the broken parts and applying the necessary lenses.

Globe valves that are scrapped on account of the seat being badly cut, stem bent, handle broken off or lost, are easily re-

Reflex water gage glasses are reground on a machine constructed in the shop, at a cost of three cents each. Bullseye lubricator glasses are reground on an Aloxite wheel and polished and returned to service at a cost of one cent each.

All of our oil is received in metal drums and as a consequence a considerable amount of heavy bodied oil sticks to the side of the drums, especially so in cold weather. The drums are heated and the oil collected and used about the shops for the lubrication of machinery.

Car wheels that are slid flat and removed, and which would otherwise be scrapped, are placed in a grinding machine and



Furnace for Melting Heavy Oil from Sides of Metal Barrels

the flat spots, if not too deep, are ground out and the wheels returned to service. On account of the accuracy of the grinding it gives practically ten per cent more wear than a wheel that is bored and mounted in the usual manner. The saving thus effected amounts to approximately \$600 per month.

Old carpets removed from dining and parlor cars are cut up into suitable sizes and with a plate and handle made of old car roofing, used as a dust collector in front of the journal boxes on passenger cars.

There is a great wear on the corners of coach seats, and after transferring the backs from one side to another and both corners become worn it would be necessary in order to avoid this unsightly appearance, to apply a new roll on the top of the back. To overcome this feature we save the good portions of plush removed from repairs to seats and backs and make a cap to cover the corner, thus saving the labor of transferring the seat backs or applying new plush rolls. On a first-class coach the cost of labor and material to renew the rolls on the backs would amount to about \$142, while caps can be applied at a cost of from \$14.00 to \$18.00.

Old paint is saved to make a compound for use on pipe joints. Varnish residue is drained and applied to joints and used in other places where a gum is required.

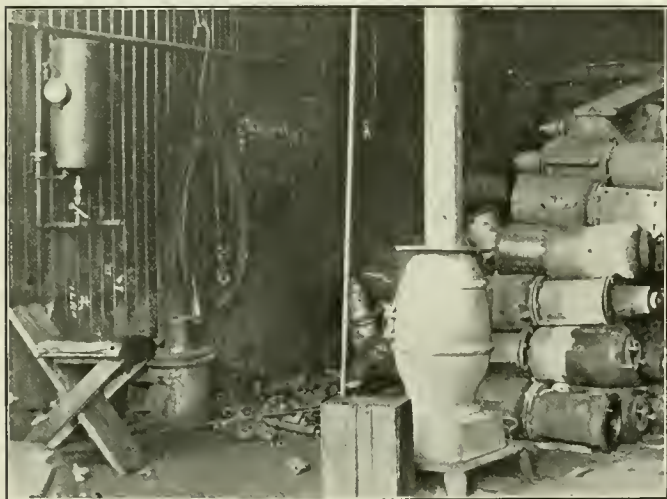

Reclaimed Air Brake Cylinders

claimed and returned to service by the renewal of the broken or worn out parts. We reclaim approximately 200 of these valves per month at a saving of about \$150.

After the old passenger car roofing is removed on account of being worn out it is placed over a furnace and all of the solder is removed, remelted into sticks and sent to the tin shop for future use. It is also surprising the amount of copper that is thus reclaimed and sent to the brass foundry. Old dope is gathered up, carefully cleaned and reapplied. Old pipe is used for sand pipes on locomotives, as well as cut up and used as thimbles for various requirements.

**HIGH SPEED DRILLS.**—A fact often lost sight of, even by experienced users of drills, is that cutting ability and hardness are not the same thing. This is especially true of high-speed drills, the apparent hardness of which varies with the composition of the steel, and is no indication of cutting ability. Some of the best high-speed tools ever tested could be filed so readily that if this were any indication of the work to be expected of them they would be condemned without a working trial. A high-speed drill that cannot be filed may, by exercising the greatest care, be made to drill extremely hard material successfully; but for softer materials it will be found so brittle as to be worthless.—*The Engineer.*

# NEW DEVICES

## MULTIPLATE VALVES

In the development of a general policy of fuel economy, that wasted because of leaky valves should be given consideration as well as that lost in other ways. Steam valves of various types are often allowed to remain in a leaky condition with a resultant fuel waste because of lack of time to regrind them, or from the lack of proper facilities.

The O'Malley-Bear Valve Company, Chicago, realizing

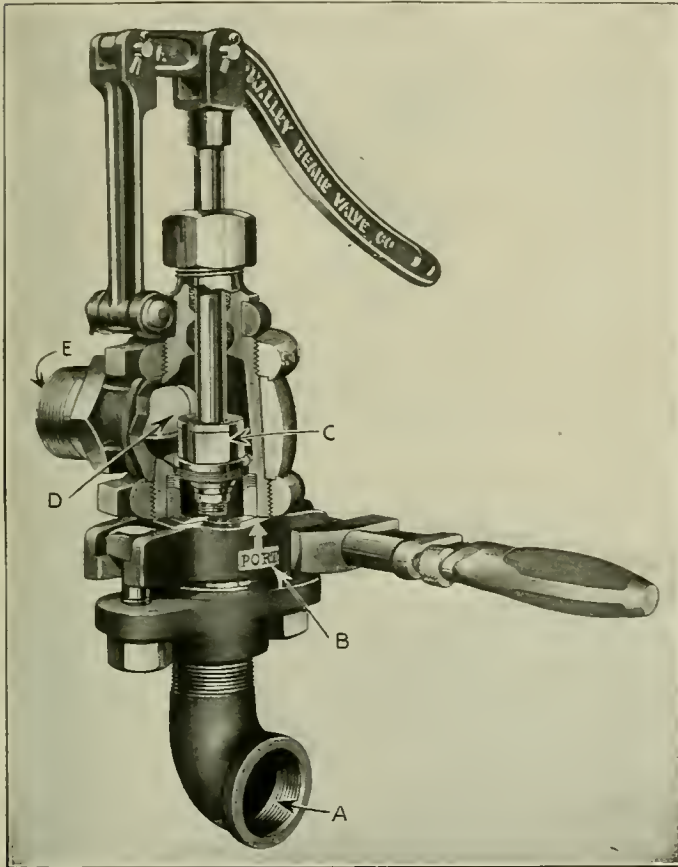

O'Malley-Bear Multiplate Blow-Off Valve

A—Outlet; B—Arrow Indicating Port Position; C—Service Valve; D—Port; E—Pressure Inlet. The monkey wrench is shown in position for cutting the valve out of service.

the need of a valve that can easily and quickly be made steam-tight by even an inexperienced workman, has developed the Multiplate valve. Its general construction is substantially the same as that ordinarily used, with the exception that the valve head and the valve seat are made up of several uniform superimposed metal plates held in place with suitable retaining nuts. As the valve wears and begins to leak, the bonnet is removed and a plate from both the seat and the head is discarded from the magazine of plates in the valve. The bonnet is then replaced, the valve being in the same condition as when new. As the plates are used they may be replaced by new ones. In case there are none at hand the valves can be used without them, the master seats in the valves being properly machined for this purpose. The thickness of the plates represents the amount of metal that is ground off the heads and seats of valves of other types when it is necessary to repair them for leakage.

An interesting feature of these valves is that the parts are interchangeable with valves of other makes; that is, the bonnet of the O'Malley-Bear valve can be applied to the body of numerous other makes. Multiplate valves of all types for all classes of service are made by this company. The composition of the plates used in the seat and head varies for the service in which the valve is used. Brass plates are provided for saturated steam valves, composition nickel and Monel plates are provided for superheated steam valves, and a plate of special mixture is provided for the thinner gases, such as oxygen and acetylene. The plates generally used are bevel in form, but in check valves, and in other valves where suitable, flat plates are used.

In addition to the medium and extra heavy valves, this company makes a Duplex Multiplate blow-off valve that is especially adapted to locomotive service. It is so constructed that the valve seat and the valve head can be removed for

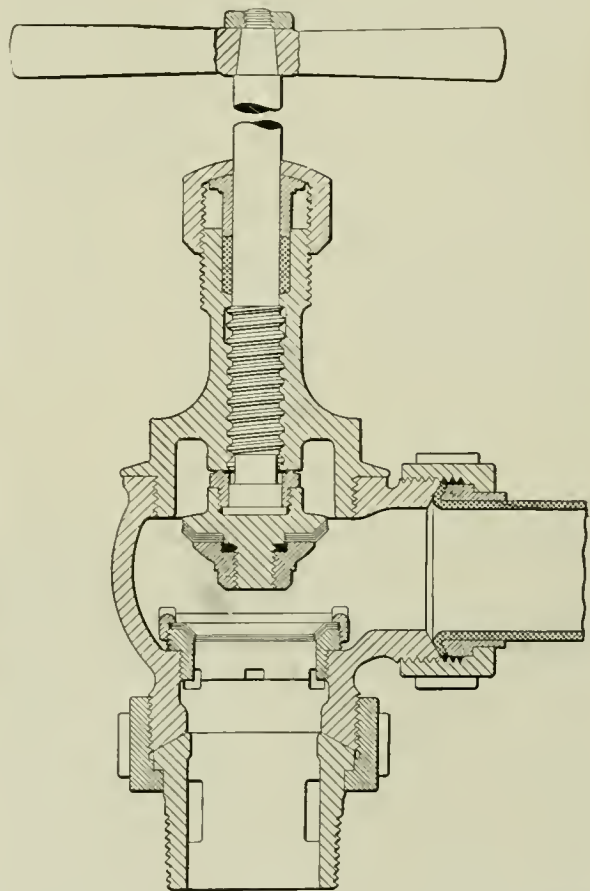

Two-Inch Injector Fountain Stop Valve Showing the Seat Plates and the Nut Securing Them

repairs with the boiler under pressure. The construction of this valve is shown in the illustrations. The valve body *A* has a steam tight taper fit in the outer casing *B*. An opening in the valve body when placed in line with the boiler connection cuts in the valve. By turning the valve body around 90 deg. the valve is cut out and at this time the valve seat and head can be removed. The valve seat is removed by releasing the seat bolts *C*, and the valve head is removed by removing the handle of the valve and the clevis *D*, and pushing the valve stem down through the valve. Notations are

cast in the outer casing and in the exposed part of the valve casing to show the position of the port in the valve body with respect to the boiler connection. The valve body is held in the outer casing by the adjusting ring *E* and the lock ring *F*. If after long service the valve body should stick in the casing

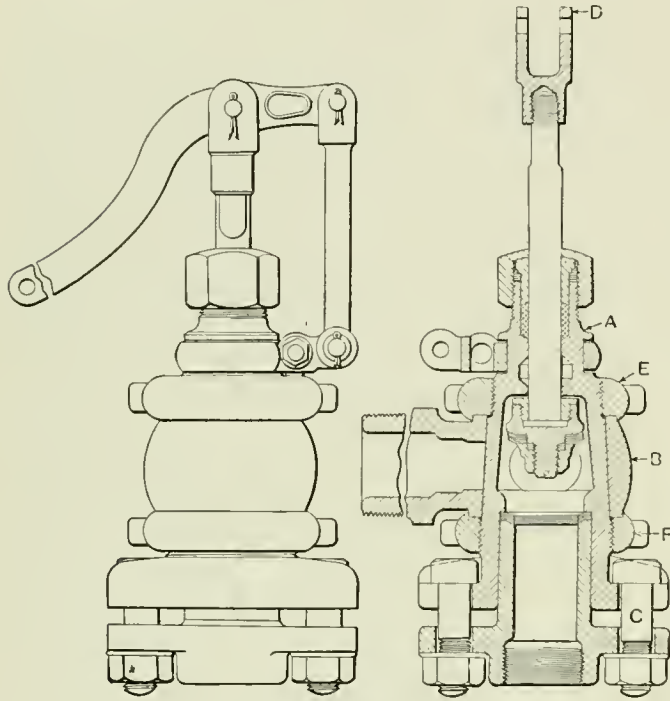

Multiplate Blow-Off Valve

when it is desired to cut out the valve, it can be relieved by a slight adjustment of these nuts. The same general principle is followed in the application of the valve plates in this valve as in the other types of valves.

### IMPROVED DROP PIT

In removing driving wheels from a locomotive by means of a drop pit the ordinary practice is to place the engine so

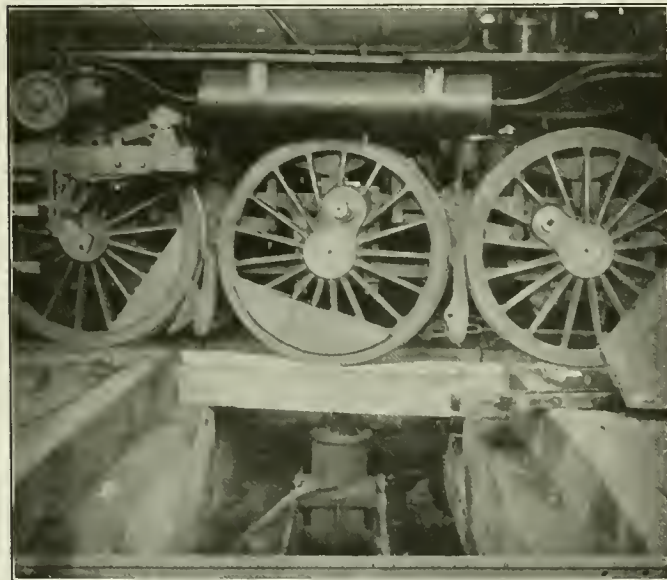

Locomotive in Position Ready for Removal of Wheels

that the wheels which are to be removed are over the pit and then raise the locomotive by means of jacks. In order to obviate the necessity of jacking up the locomotive, a

method of removing the wheels by blocking over the driving boxes to take the weight off the axle, has been devised by

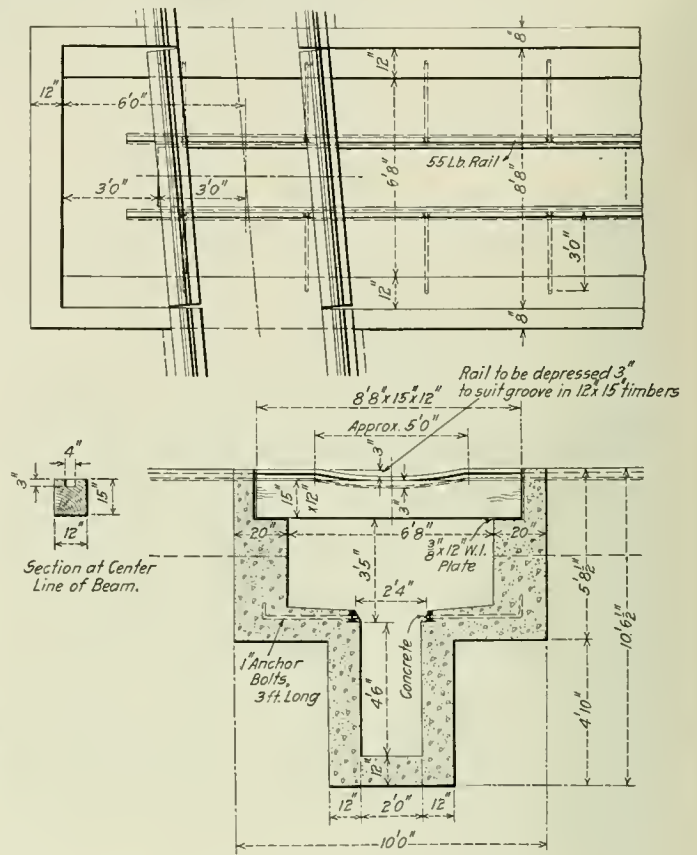

General Arrangement of the Drop Pit

W. J. Pamplin and S. C. Morton, Waycross, Ga. In using this drop pit, which is shown in the illustrations, blocks are

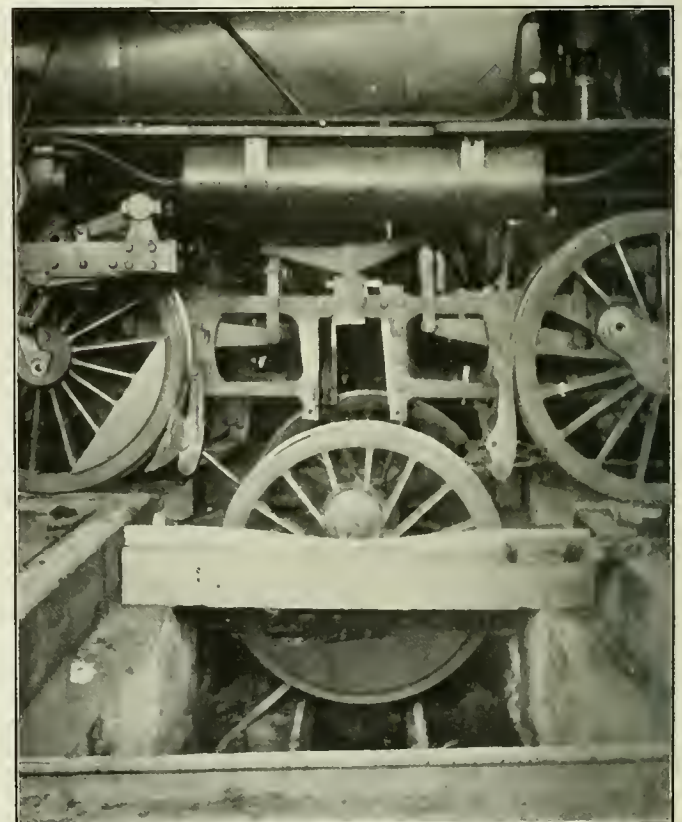

Drop Pit in Use Lowering a Pair of Driving Wheels

placed over the driving boxes of the wheels which are to be removed and the engine is then run over the pit, this pair of driving wheels being lowered by means of a depression in the pit rail. The weight is thus relieved from the axle and the ordinary form of drop pit jack is run up and raises the wheels enough so that the pit rails may be removed. The jack is then lowered and the wheels transferred to the next adjoining track and raised to the floor level as in the ordinary form of drop pit.

This design of drop pit has been patented by the inventors. In one case where it is in use on the Atlantic Coast Line, the main driving wheels were removed from a locomotive, the brasses rebored and refitted and the wheels replaced, the entire work from the time the engine was placed over the pit until it was again ready for service being accomplished by a machinist and two helpers in six and one-half hours.

### DETROIT BALL VALVE

The accompanying illustration shows the ball valve made by the Detroit Valve Company, Detroit, Mich. The interesting feature of this valve is, as the name implies, the ball disc. This ball, which is made of a hard bell metal, is held suspended in a case, being free to rotate in any direction. The valve seat is of a socket form, being rounded to an angle of 45 deg. In closing the valve the ball is lowered onto its seat, but it is not ground in as is the case with a flat valve disc on a flat seated valve. Further turning of the valve

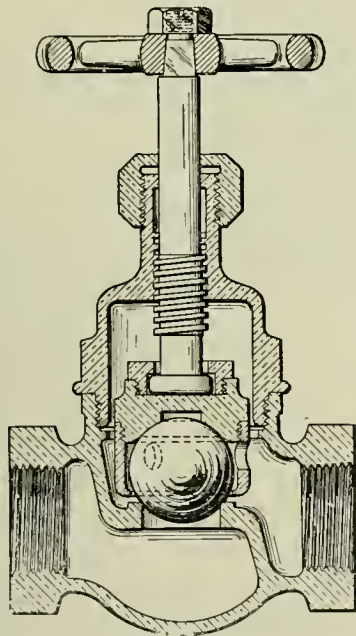

Globe Valve Closing with Spherical Joint

stem presses the ball tightly into its seat, while the cupped cage holder slightly rotates around the ball. It makes, in fact, a ball and socket joint. In opening, the ball valve case releases its grip on the ball, lifting it off the seat without any grinding effect on either the ball disc or the seat. As the valve is opened the ball will be rotated slightly, thus giving a constantly changing surface each time the valve is operated. This same plan is adopted for globe, angle and check valves, the parts being interchangeable for each size of valve.

The Duntley Products Sales Company, Fisher building, Chicago, Ill., has been granted exclusive railway sales rights for this valve.

**WEIGHT OF OIL.**—The lightest oil used for lubrication has a specific gravity of about 0.865 and the heaviest about 0.930. The commercial range is from 0.885 to 0.907.—*Power.*

### UNIVERSAL GRAIN DOOR

An efficient and practical grain door which has been in use on 50,000 cars in this country, and is the standard on some roads, has been placed on the market by the Universal Grain Door Company, Transportation building, Chicago. This door was formerly known as the McNulty nailless grain door; no nails whatever are required in its application to a car. With it a car can be coopered for a shipment of grain in five minutes and the door can be removed under load in less than two minutes. In either its application or removal it is unnecessary to mutilate either the door posts of the car or the grain door itself. The fact that no nails are required in its application is a decided advantage, for where these nails are used the door post soon becomes badly mutilated. One of the illustrations shows such a post and the damaging effect of such conditions to other freight is apparent, especially to shipments of flour in bags. One road attempted to remove all nails in the door post before offering the cars to shippers of such commodities, but this was found to be an expensive practice.

The ease with which this door may be removed is an im-



Universal Grain Door

portant factor from the standpoint of the amount of grain handled at the elevators. With the ordinary nailed door it takes from 10 to 20 minutes to clear the doorway so that the shovelers may enter the car. By reducing this time to less than two minutes the number of cars handled at an elevator may be increased from 20 to 25 per cent, which is an important item to both the railroads and the elevator operators, as more grain can be handled per day and the cars will be more promptly released when they are needed most. This door is handled in the same manner as the ordinary grain

door, that is, it is not a permanent part of the car. When removed from a car the doors may be used in any other car or shipped back to the grain fields for further use. It is a permanent door temporarily used.

The construction of the door is quite simple. It is made in three parts, similar to the ordinary nailed door, preferably of 1 5/8 in. dressed ship-lapped lumber. A relief door of sheet metal is provided in the lower section. This door slides

from two to four trips, in that they may be used several times with practically no repairs, and that they can be applied and removed in a very short time. The labor and material required in their application are much less than with the ordinary type of nailed door in that no nails are required,

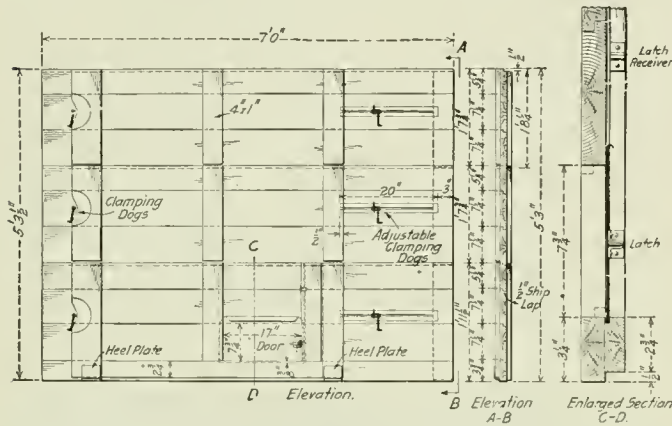

Details Showing Location of the Clamping Dogs

in metal guides and provides an opening 17 in. by 7 3/4 in. It is held opened or closed by a small latch. The doors are held firmly to the door posts by clamping dogs driven into the sides of the door posts, two to each door. They have sufficient rake to pull the door tight to the posts as they are driven in. A fixed dog is applied at one end of the door and an adjustable dog at the other, in order to provide for the varying widths of car door openings. The adjustable dog is keyed to a crimped sliding piece fixed in the door, as

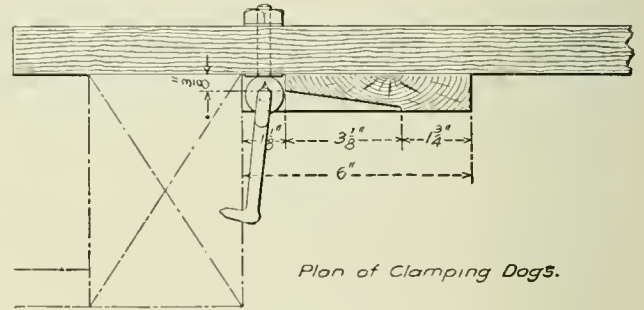
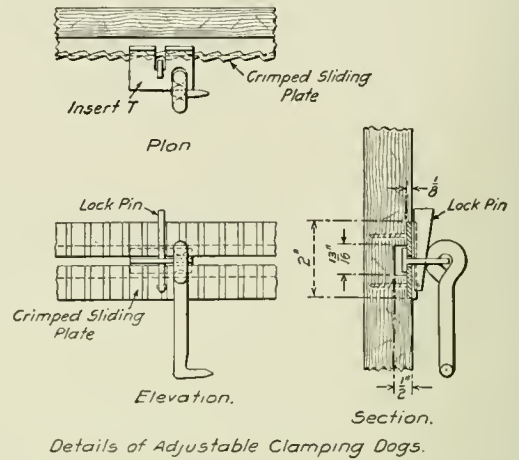

Details of the Clamping Dogs

and there is no occasion to destroy the doors in unloading the cars. These doors can be applied grain tight, and some roads that are using them report that the claims for grain losses have been reduced by their use.



Door Post Damaged by Use of an Ordinary Type Grain Door

indicated in the illustrations. Provision has been made for the use of bars when removing the doors, two heel plates being provided at the lower end of two of the battens in the lower door.

It is claimed that these doors will pay for themselves in

### AJAX THIRD POINT SUPPORT

There is a tendency for the forward end of a brake beam to tilt downward when the brakes are in the release position, due to its own weight plus the added weight of the levers and connections. This sometimes brings the levers and the

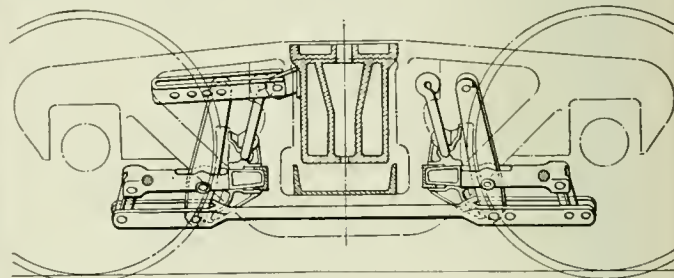

Ajax Third Point Support

end of the brake beams low enough to strike crossing planks and obstructions between the rails which is liable to tear off the rigging and cause derailments. It also causes the upper part of the brake shoes to drag on the wheels, producing uneven brake shoe wear and some retarding effect to the train. Furthermore, with the brake beam in this position an application of the brakes brings the brake beam to its acting position with a jerk, causing irregular stresses on the beam.

To overcome these undesirable features the American Steel

Foundries, Chicago, has brought out the Ajax third point support for brake beams. It consists of a link hung from the end of the brake beam and supporting the end of the bottom brake rod. It is simple in construction and in addition to keeping the brake beam in proper alinement it serves as a safety device in that the bottom brake rod connection will be held in place should the pin connecting it with the brake lever become lost.

**PNEUMATIC DOOR RING RIVETER**

The type of pneumatic riveter shown in the illustration has been developed especially for driving boiler door ring rivets. The main frame is a steel casting to which are secured the cylinder, the stake and the operating mechanism. It is designed for swinging suspension and the arrangement is simple and compact.

This machine is built by the Vulcan Engineering Sales Company, Chicago, and employs the Hanna operating mechanism. This provides a gradually increasing pressure

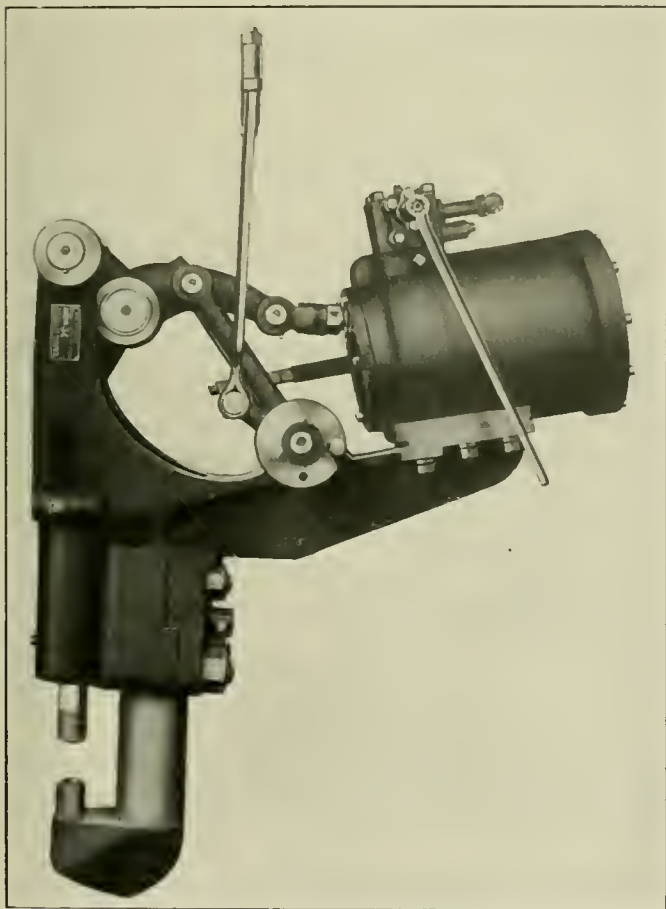

Hanna Door Ring Riveter

through the greater part of the stroke until the desired maximum is reached, after which the pressure remains uniform until the completion of the stroke. The toggle mechanism, the plunger and the piston head are steel castings. High carbon steel is used for the piston rod, die screw, lower die holder and dies.

**LIQUID FOR HYDRAULIC JACKS.**—A hydraulic jack should be filled with alcohol 1 part, water 2 parts, with a tablespoonful of sperm oil added. It should never be filled with water, kerosene or wood alcohol. Water is liable to freeze or rust the jack; kerosene destroys the packing; wood alcohol destroys packing and corrodes the metal.—*Engineering and Mining Journal*.

**CYCLOIDAL WEIR METER**

A water meter of the weir type has recently been developed by the Kennicott Company, Chicago Heights, Ill., in which the rate of flow varies directly as the head of water in the weir chamber. The arrangement of the device is shown in the drawing. Other forms of weirs in common use are objectionable when applied to recording meters because of the complicated recording apparatus required, the rate of flow in every case being a more or less complicated function of the head. With the cycloidal weir the direct proportion of the rate of flow to the head makes possible the use of the simplest form of recording mechanism and accuracy may be obtained without difficulty.

The weir itself is a simple box casting, the upper surface of which is cycloidal in contour. It is open at the bottom and is bolted or riveted over a slot in the bottom of the weir

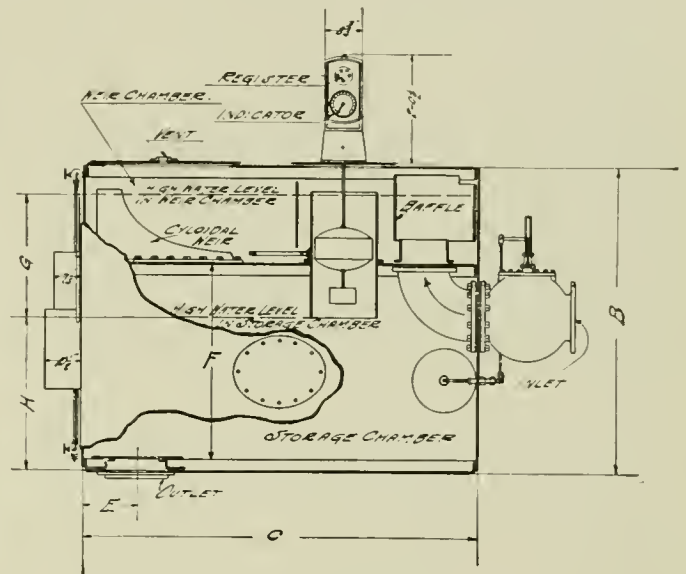

Cycloidal Weir Meter; Rate of Flow Varies Directly with the Head

chamber. Throughout the length of the cycloidal surface is a slot accurately machined to a uniform width through which the water flows from the weir chamber to the storage chamber in the lower part of the meter. With this device it will be readily seen that as the height of the water increases, thus increasing the rate of flow though the lower part of the weir, the relative length of the weir slot exposed gradually decreases, thus compensating for the effect of the increased head over the lower portion of the weir. Patents have been secured covering the form of the weir.

**AUTOGENOUS WELDING IN BOILER REPAIRS.**—Autogenous welding for effecting boiler repairs is convenient in many instances, but its advantages are apt to lead to oversight of the real causes which produce the defects the welding is intended to remedy.—*The Engineer*.

**BLOWING OUT STATIONARY BOILER TUBES.**—The frequency with which the blower should be used depends on the type of boiler, the soot-producing qualities of the fuel, the efficiency of firing, and on whether a hand blower or a mechanical blower is used. If the blower is of the mechanical kind that is fixed permanently in place and that blows all the tubes at one time, the labor required to operate it is reduced, and blowing may be done two or three times in a day of 24 hours. But if the hand-operated, single-jet blower is used, the labor involved reduces the number of cleanings to one a day. It seems to be generally conceded that the tubes should be blown at least once a day. But if much soot is formed it will be found economical to blow them out oftener, even at the expense of additional labor.—*Electrical World*.

# Railway Mechanical Engineer

(Formerly the RAILWAY AGE GAZETTE, MECHANICAL EDITION with which the AMERICAN ENGINEER was incorporated)

PUBLISHED ON THE FIRST THURSDAY OF EVERY MONTH BY THE SIMMONS-BOARDMAN PUBLISHING COMPANY

EDWARD A. SIMMONS, *President* L. B. SHERMAN, *Vice-President*  
HENRY LEE, *Vice-President and Treasurer* M. H. WIUM, *Secretary*  
WOOLWORTH BUILDING, NEW YORK, N. Y.

Chicago: Transportation Bldg. Cleveland: Citizens' Bldg.  
London: Queen Anne's Chambers, Westminster.

ROY V. WRIGHT, *Editor*  
A. C. LOUDON, *Managing Editor*  
R. E. THAYER, *Associate Editor* C. B. PECK, *Associate Editor*

Entered at the Post Office at New York, N. Y., as mail matter of the second class.

Subscriptions, including the eight daily editions of the *Railway Age Gazette* published in June in connection with the annual conventions of the Master Car Builders' and American Railway Master Mechanics' Associations, payable in advance and postage free: United States, Canada and Mexico, \$2.00 a year; Foreign Countries (excepting daily editions), \$3.00 a year; Single Copy, 20 cents.

WE GUARANTEE, that of this issue 7,800 copies were printed; that of these 7,800 copies, 6,790 were mailed to regular paid subscribers, 95 were provided for counter and news companies' sales, 357 were mailed to advertisers, exchanges and correspondents, and 558 were provided for new subscriptions, samples, copies lost in the mail and office use; that the total copies printed this year to date were 23,400, an average of 7,800 copies a month.

The RAILWAY MECHANICAL ENGINEER, and all other Simmons-Boardman publications are members of the Audit Bureau of Circulations.

VOLUME 90

MARCH, 1916

NUMBER 3

## CONTENTS

### EDITORIALS:

Passenger Car Terminal Competition.....	111
Horizontal Sheathing on Box Cars.....	111
Increasing the Length of Locomotive Runs.....	111
What Is Heat-Treated Steel?.....	111
The Reinforcing of Underframes.....	111
Design of New Equipment.....	112
The Enginehouse Competition.....	112
Organization and Low Maintenance Costs.....	112
Maintenance of Steel Cars.....	112
Road Conditions and Locomotive Types.....	113
New Books.....	113

### GENERAL:

Pulverized Fuel for Locomotives.....	114
Graphite in Locomotive Valve Chambers and Cylinders.....	118
Incandescent Headlights and Headlight Laws.....	119
Coal Counter for Use in Locomotive Tests.....	120
Norfolk & Western Electrification.....	121
Spontaneous Combustion of Coal.....	124
Water Readings in Locomotive Tests.....	126

### CAR DEPARTMENT:

Ratio of Stress to End Load for Freight Car Center Sills.....	127
Tank Car Specifications Modified.....	128
Turning Car Journals.....	128
Letter Board Splice.....	128
Life and Maintenance of All-Steel Cars.....	129
Car Foremen's Responsibility for Air Brake Conditions.....	134
Santa Fe Refrigerator Cars.....	135
Freight Car Construction, Maintenance and Abuse.....	139

### SHOP PRACTICE:

Taper Attachment for Turret Lathes.....	141
Never Slight a Job.....	142
Anti-Friction Bearings for Shop Motors.....	142
Holding Distributing Valves in Making Repairs.....	142
Efficient Enginehouse Organization.....	143
Vise Chuck for Filing Piston Rings.....	146

A Broad Conception of Apprenticeship.....	146
Pump for Testing Boilers.....	147
Rules for the Safe Handling of Paints and Oils.....	147
Chesapeake & Ohio Scrap Reclamation.....	149

### NEW DEVICES:

Multiplate Valves.....	153
Improved Drop Pit.....	154
Detroit Ball Valve.....	155
Universal Grain Door.....	155
Ajax Third Point Support.....	156
Pneumatic Door Ring Riveter.....	157
Cycloidal Weir Meter.....	157

### NEWS DEPARTMENT:

Notes.....	158
Meetings and Conventions.....	159
Personals.....	160
New Shops.....	160
Supply Trade Notes.....	161
Catalogues.....	164

## NEWS DEPARTMENT

According to a press report the Canadian Pacific has decided to use only Canadian hardwoods for interior finish of sleeping, parlor, dining and observation cars as well as offices and hotel buildings.

The Southern Pacific has announced that at the end of the fiscal year it will award a watch fob, with a gold charm, to each of the six men on each division and in each general shop who rank highest in the number of points scored for safety suggestions.

The Baltimore & Ohio's Safety First campaign during the past year has produced gratifying results. Employees have held 204 safety committee meetings, and have made 17,066 recommendations in the interest of safety; and 16,411, or 96 per cent, of these were disposed of. To the general use of goggles by mechanics, the company's physician attributes a prevention of fifteen injuries to employees' eyes on one division. There has been a decrease in the number of accidents, though the force was augmented to handle increased business, and inexperienced men were taken into the service.

The management of the Atchison, Topeka & Santa Fe has selected four recent graduates in woodworking from among the apprentices in the Topeka shops, and has arranged for them a special course of six months in the shops of the Pullman Company, where arrangements have been made to give the apprentices every opportunity possible to familiarize themselves with the Pullman Company's method of constructing cars. Some time ago the Santa Fe selected seven of its brightest machinist apprentice graduates for a similar special course at the plant of the Baldwin Locomotive Works.

The Pennsylvania Railroad reports that its fire losses on the whole system last year amounted to only eight cents on each \$100 of property at risk. The total fire loss for the year was \$278,730, which was paid out of the road's own insurance fund. The value of the property exposed to fire hazard, and insured by the fund, is about \$350,000,000. Employees extinguished 441 fires, buildings, yards, etc., before the arrival of public fire companies. Organized fire brigades among the employees put out 84 of these fires, and locomotives equipped with fire fighting apparatus were used in putting out 40 fires. High pressure fire lines built by the railroad were used in six fires. Spontaneous combustion caused 15 fires, 36 started on adjacent property, and 12 were of incendiary origin. Lightning caused 2, boys 2, and tramps 11, while 130 were of unknown origin. Carelessness with tobacco and matches caused 12 fires which destroyed \$10,091 worth of property.



**CARS AND LOCOMOTIVES ORDERED IN FEBRUARY**

The orders for freight and passenger cars reported during the month of February did not come up to the high level set in the last three months of 1915, nor were they as large in amount as those reported during January. The orders for locomotives, on the other hand, were unusually large, the total for the month being greater than that for any month during the last two years. The totals were as follows:

	Locomotives	Freight cars	Passenger cars
Domestic .....	534	12,988	75
Foreign .....	479	3,200	..
Total .....	1,013	16,188	75

The New York Central will receive a large proportion of all the locomotives ordered during the month, it having contracted with the Lima Locomotive Corporation for 70 Mikado and 25 eight-wheel switching locomotives, and with the American Locomotive Company for 29 Mountain type, 25 eight-wheel switching and three Mallet type locomotives. It has also authorized certain of its own shops to proceed with the construction of about 150 locomotives, a total of 302 locomotives. It is also understood, further, that the company contemplates purchasing 100 more locomotives from outside builders. Other important domestic and foreign orders were as follows:

Road	No.	Type	Builder
Baltimore & Ohio.....	50	Mikado	Baldwin
	10	Mogul	Lima
Bessemer & Lake Erie....	20	Santa Fe	Baldwin
Illinois Central .....	20	Pacific	American
Lehigh Valley .....	20	Mikado	Baldwin
Southern Pacific .....	20	Pacific	American
Cuba Railroad .....	25	Ten-wheel	American
English Government.....	20	.....	Baldwin
French Government.....	80	Pechot	Baldwin
Russian Government.....	350	Gasolene	American

The last named order is for 7-ton narrow gage locomotives.

Among the important freight car orders were the following:

Road	No.	Type	Builder
Bessemer & Lake Erie....	750	Gondola	Pressed Steel
	750	Gondola	Standard Steel
	500	Gondola	Amer. Car & Fdy. Co.
	500	Gondola	Ralston
Lackawanna Steel Company	700	Hopper	Amer. Car & Fdy. Co.
	700	Hopper	Standard Steel
Southern Pacific.....	900	Box	Ralston
	760	Stock	Ralston
	650	Flat	Ralston
	275	Flat Bodies	Ralston
	1000	Box	Haskell & Barker
	250	Gondola	Haskell & Barker
	3	Caboose	Mt. Vernon
	601	Automobile	Ralston
	303	Tank	Amer. Car & Fdy. Co.
Cuba Railroad .....	350	Flat	Amer. Car & Fdy. Co.
	350	Box	Amer. Car & Fdy. Co.
	500	Cane	Amer. Car & Fdy. Co.

The important passenger car orders included the following: International & Great Northern, 5 coaches, 2 dining and 2 postal cars, American Car & Foundry Company, and the Southern Pacific, 10 baggage, 20 combination baggage and mail, 2 combination passenger and baggage cars, and 18 coaches, Pullman Company.

**EXHIBITS AT THE JUNE MECHANICAL CONVENTIONS**

The exhibit committee of the Railway Supply Manufacturers' Association held a meeting at the office of the association in the Oliver building, Pittsburgh, on February 18, for the purpose of assigning space for exhibits, making arrangements for hotels, furniture, decorations, etc.

About 70,000 square feet of space was assigned. Announcement was made that the association has also received a large number of inquiries concerning space, many of which will doubtless result in formal applications. Too much emphasis cannot be given to the request that those desiring exhibit space file their applications immediately as the remaining space is rapidly being taken. The committee expects to issue circulars shortly concerning the arrangements for hotels, furniture, decorations, etc.

**MEETINGS AND CONVENTIONS**

*Central Railway Club.*—The annual meeting and dinner of the Central Railway Club will be held at the Hotel Statler, Buffalo, N. Y., on March 9, 1916. The business session will be held in the afternoon at two o'clock, followed by a reception and dinner at seven o'clock in the evening.

*Air Brake Association.*—The twenty-third annual convention of the Air Brake Association will be held May 2-5, 1916, at the Hotel Ansley, Atlanta, Ga. The following subjects will be considered at the convention: Slack action in long passenger trains, its relation to triple valves of different types, and consequent results in the handling of passenger trains; proper piping of locomotives and cars, specifications and requirements for pipe in air brake work; adequate hand brakes in heavy passenger equipment cars; best method of educating apprentices to give the railroad companies efficient air brake mechanics; care of modern passenger brake equipment and factors contributing to the minimum cost of maintenance with the maximum efficiency; accumulation of moisture and its elimination from trains and yard testing plants; need of efficient cleaning and repairing of freight brakes, and recommended practice.

The following list gives names of secretaries, dates of next or regular meetings and places of meeting of mechanical associations:

- AIR BRAKE ASSOCIATION.**—F. M. Nellis, 53 State St., Boston, Mass. Convention, May 2-5, 1916, Atlanta, Ga.
- AMERICAN RAILROAD MASTER TINNERS', COPPERSMITHS' AND PIPEFITTERS' ASSOCIATION.**—W. E. Jones, C. & N. W., 3814 Fulton St., Chicago.
- AMERICAN RAILWAY MASTER MECHANICS' ASSOCIATION.**—J. W. Taylor, Karpen Building, Chicago. Convention, June 19, 1916, Atlantic City, N. J.
- AMERICAN RAILWAY TOOL FOREMEN'S ASSOCIATION.**—Owen D. Kinsey, Illinois Central, Chicago. Convention, July, 1916.
- AMERICAN SOCIETY FOR TESTING MATERIALS.**—Prof. E. Marburg, University of Pennsylvania, Philadelphia, Pa. Convention, June 27-July 1, Traymore Hotel, Atlantic City, N. J.
- AMERICAN SOCIETY OF MECHANICAL ENGINEERS.**—Calvin W. Rice, 29 W. Thirty-ninth St., New York.
- ASSOCIATION OF RAILWAY ELECTRICAL ENGINEERS.**—Joseph A. Andreucetti, C. & N. W., Room 411, C. & N. W. Station, Chicago.
- CAR FOREMEN'S ASSOCIATION OF CHICAGO.**—Aaron Kline, 841 Lawlor Ave., Chicago. Second Monday in month, except July and August, Hotel La Salle, Chicago.
- CHIEF INTERCHANGE CAR INSPECTORS' AND CAR FOREMEN'S ASSOCIATION.**—W. R. McMunn, New York Central, Albany, N. Y.
- INTERNATIONAL RAILWAY FUEL ASSOCIATION.**—J. G. Crawford, 547 W. Jackson Blvd., Chicago. Convention, May 15-18, Hotel Sherman, Chicago.
- INTERNATIONAL RAILWAY GENERAL FOREMEN'S ASSOCIATION.**—William Hall, 1126 W. Broadway, Winona, Minn. Convention, August 29-31, 1916, Hotel Sherman, Chicago.
- INTERNATIONAL RAILROAD MASTER BLACKSMITHS' ASSOCIATION.**—A. L. Woodworth, Lima, Ohio. Convention, August, 1916, Chicago.
- MASTER BOILER MAKERS' ASSOCIATION.**—Harry D. Vought, 95 Liberty St., New York. Convention, May 23-26, 1916, Hollenden Hotel, Cleveland, Ohio.
- MASTER CAR BUILDERS' ASSOCIATION.**—J. W. Taylor, Karpen Building, Chicago. Convention, June 14, 1916, Atlantic City, N. J.
- MASTER CAR AND LOCOMOTIVE PAINTERS' ASSOCIATION OF U. S. AND CANADA.**—A. P. Dane, B. & M., Reading, Mass. Convention, September 12-14, 1916, Wilmington, Del.
- NIAGARA FRONTIER CAR MEN'S ASSOCIATION.**—E. Frankenberger, 623 Brisbane Building, Buffalo, N. Y. Meetings monthly.
- RAILWAY STOREKEEPERS' ASSOCIATION.**—J. P. Murphy, Box C, Collinwood, Ohio. Convention, May, 1916.
- TRAVELING ENGINEERS' ASSOCIATION.**—W. O. Thompson, N. Y. C. R. R., Cleveland, Ohio. Convention, September, 1916, Chicago.

**RAILROAD CLUB MEETINGS**

Club	Next Meeting	Title of Paper	Author	Secretary	Address
Canadian .....	Mar. 14	Heat Treatment of Steel.....	G. W. Pressell..	James Powell.....	St. Lambert, Que.
Central .....	Mar. 9	Interchange Rules. Discussion.....	Committee .....	Harry D. Vought..	95 Liberty St., New York
New England....	Mar. 14	Annual Meeting, Election of Officers.....	.....	Wm. Cade, Jr.....	683 Atlantic Ave., Boston, Mass.
New York.....	Mar. 17	Annual Electrical Night.....	.....	Harry D. Vought..	95 Liberty St., New York
Pittsburgh .....	Mar. 25	Interchange Rules; Repairs to Foreign Cars	E. S. Way.....	J. B. Anderson....	207 Penn Station, Pittsburgh, Pa.
Richmond .....	Mar. 13	Train Handling by Air.....	Robert Burgess..	F. O. Robinson....	C. & O. Ry., Richmond, Va.
St. Louis .....	Mar. 10	The Railroad Eight-Hour Movement.....	W. L. Park.....	B. W. Frauenthal..	Union Station, St. Louis, Mo.
South'n & S'w'rn.	Mar. 16	Nature's Invisible Forces.....	T. H. Ellis.....	A. J. Merrill.....	Box 1205, Atlanta, Ga.
Western .....	Mar. 21	.....	.....	Jos. W. Taylor.....	1112 Karpen Bldg., Chicago

## PERSONAL

### GENERAL

CHARLES A. BINGAMAN, assistant engineer of motive power of the Philadelphia & Reading, at Reading, Pa., has been appointed mechanical engineer of the Philadelphia & Reading and subsidiary companies. The position of assistant engineer of motive power has been abolished.

PHILIP H. CONNIFF has been appointed assistant superintendent of motive power and machinery of the Florida East Coast, with headquarters at St. Augustine, Fla.

F. G. LISTER has been appointed mechanical engineer of the El Paso & Southwestern, with office at El Paso, Tex. Mr. Lister previously served on the Spokane, Portland & Seattle and affiliated lines at Portland, Ore.

T. D. SEDWICK, chief chemist of the Chicago, Rock Island & Pacific, has been appointed acting engineer of tests in place of F. O. Bunnell, resigned.

### MASTER MECHANICS AND ROAD FOREMEN OF ENGINES

A. C. ADAMS has been appointed master mechanic of the Virginia division of the Seaboard Air Line, at Raleigh, N. C., succeeding G. H. Langton.

B. P. JOHNSON has been appointed master mechanic of the Seattle division of the Northern Pacific, with headquarters at Seattle, Wash., succeeding C. S. Larrison, deceased.

E. J. HARRIS has been appointed master mechanic of the Missouri division of the Chicago, Rock Island & Pacific, succeeding P. Linthicum, acting master mechanic, transferred.

G. F. SMITH has been appointed master mechanic of the Colorado, Kansas & Oklahoma, at Scott City, Kans.

MINOT R. SMITH has been appointed master mechanic of the Wyoming division of the Lehigh Valley, with headquarters at Coxton, Pa. Mr. Smith was born at Erie, Pa., November 5, 1870. He received his education in the public schools of Huntington, W. Va., and in Marshall College, located in that place. He entered railroad service as a machinist apprentice on the Chesapeake & Ohio at Huntington, in 1887, where he served in that capacity and as a machinist until 1899. He was then made machine shop foreman on the same railroad at Covington, Ky., in which capacity he served until his appointment as general foreman at Russell, Ky., in 1904. In 1910 he left the C. & O. to become machine shop foreman for the Louisville & Nashville at New Decatur, Ala., and later in the same year was appointed division master mechanic and shop superintendent of the Monon at Lafayette, Ind. Here he remained until his recent appointment with the Lehigh Valley.

B. P. JOHNSON has been appointed master mechanic of the Northern Pacific at Seattle, Wash., succeeding C. S. Larrison, deceased. Mr. Johnson was born October 1, 1869, at Mt. Holly, N. J., and received a common school education in Camden, N. J. Prior to entering railroad service Mr. Johnson served as a machinist apprentice in a jobbing shop in Philadelphia, Pa. His first railway service was with the Northern Pacific at Glendive, Mont., where he began work as a section hand in December, 1888. After serving in this capacity and as a car oiler for about a month he was transferred to the roundhouse where he served successively as caller, hostler's helper and boiler washer until 1890 when he became a locomotive fireman. He received his promotion as engineer in August, 1898, and served in that capacity until September, 1903, when he was appointed road foreman of engines. In April, 1908, he was appointed master mechanic at Glendive, which position he occupied until transferred to Seattle.

### SHOP AND ENGINE HOUSE

G. H. LANGTON, master mechanic of the Seaboard Air Line at Raleigh, N. C., has been appointed shop superintendent of the Portsmouth, Va., shops, succeeding L. D. Freeman, who has been granted leave of absence on account of ill health.

### PURCHASING AND STOREKEEPING

G. W. CONWAY has been appointed general storekeeper of the Louisville & Nashville, with office at Louisville, Ky., succeeding S. G. Conner, deceased.

EDWIN MEYERS has been appointed assistant general storekeeper of the Louisville & Nashville, with headquarters at Louisville, Ky.

E. W. MYERS has been appointed storekeeper of the Duluth, Winnipeg & Pacific at Virginia, Minn., succeeding F. S. Matthey, resigned.

RUSSELL L. UNDERWOOD has been appointed storekeeper of the Cincinnati Northern, with office at Van Wert, Ohio, succeeding F. P. Clark, resigned to engage in private business.

### OBITUARY

FREDERICK W. BUSSE, chief clerk to the general superintendent of motive power of the Baltimore & Ohio at Baltimore, Md., died in that city on February 24, at the age of 56 years. Mr. Busse had occupied that position since May 1, 1903.

SMITH G. CONNER, formerly general storekeeper of the Louisville & Nashville, died recently after a very short illness at his home in Louisville, Ky.

GEORGE A. HANCOCK, formerly general superintendent of motive power of the St. Louis & San Francisco, died suddenly on February 8, at Los Angeles, Cal., where he resided during the winter of each year. He retired from the service of the Frisco in 1912.

HARVEY L. LEWIS, formerly foreman of the car shops of the New York, Ontario & Western at Norwich, N. Y., died in that city on January 26, at the age of 41.

A. SHIELDS, who was master mechanic of the Canadian Northern at Winnipeg, Man., previous to 1912, died on January 18, in Rochester, Minn., at the age of 48.

CALVIN G. TURNER, until 1913 master mechanic of the Philadelphia, Baltimore & Washington at Wilmington, Del., died on January 25, at his home in Wilmington at the age of 64.

### NEW SHOPS

VANDALIA.—This company is constructing an enginehouse layout which comprises a small four-stall roundhouse, a sandhouse, oil house and ash pit, at Bickness, Ind. This will cost about \$20,000.

PENNSYLVANIA RAILROAD.—According to a newspaper report, the Pennsylvania is planning improvements to the Altoona, Pa., car shops, the most important of which is the installing of two new ovens for drying paint on passenger cars.

SOUTHERN RAILWAY.—This company will provide a special shop for repairs to steel cars at the Coster shops near Knoxville, Tenn. The new facilities will consist of an all-steel main shed 73 ft. by 480 ft., through which will extend three tracks, and a workshop 51 ft. by 100 ft., both to be equipped with overhead power cranes and a full complement of machinery and tools for repairing steel cars.

ATCHISON, TOPEKA & SANTA FE.—Final plans and specifications are being prepared for a new blacksmith shop at Albuquerque, N. M. It will be a steel-frame, brick structure with metal sash windows, 30 ft. long by 80 ft. wide, to cost approximately \$60,000.

## SUPPLY TRADE NOTES

A. B. Wegener has been appointed general manager of sales of the Camel Company, with headquarters at Chicago, Ill.

Herbert W. Wolff has been appointed vice-president of the American Car & Foundry Company, in charge of sales, with office at Chicago. Mr. Wolff was born on December 27, 1873, and was educated in the public schools of Detroit, Mich. He began his business career as an employee of the Michigan Car Company at Detroit in 1886. When the Michigan and Peninsular car companies were merged in 1892 under the name of the Michigan Peninsular Car Company, he remained in the service of the consolidated corporation. He was assistant mechanical engineer of this company in 1899, when the American Car & Foundry Company was formed, and went to St. Louis, Mo., to become chief mechanical engineer of the new company. In 1912 he was appointed assistant to the vice-president, with headquarters at St. Louis, which position he held until his recent promotion to the vice-presidency.



H. W. Wolff

P. M. Elliott, general manager of the Camel Company of Chicago, Ill., was recently elected vice-president of that company.

F. V. McGinness has been appointed manager of the railway department of the Edison Storage Battery Company. Mr. McGinness is a graduate of Columbia University, having received the degree of electrical engineer in 1910. After graduation he was, for a short time, with the New York & New Jersey Telephone Company and also with the New York & Queens Electric Light & Power Company at Long Island City, N. Y. In the latter connection he was occupied chiefly with computing distribution systems although at this time he received some practical battery experience. He became connected with the Edison forces in 1911, being then engaged in experimental work in Mr. Edison's laboratory. At this time he also received a through training in the manufacture of the Edison battery. Mr. McGinness has been engaged in railway storage battery work for the past four years. Previous to his appointment as manager of the railway department he was assistant manager of this department.



F. V. McGinness

Franklin Alter, president of the American Tool Works Company, Cincinnati, Ohio, died at his home in that city on February 27, aged 85 years.

The Q & C Company announces that it has discontinued its representation of the Ross-Schofield system of circulation of water in locomotive boilers.

F. O. Bunnell, engineer of tests of the Chicago, Rock Island & Pacific, has resigned, to become chief engineer of the Southern Wheel Company, St. Louis.

William H. Woodin, assistant to the president of the American Car & Foundry Company, has been elected president of that company, succeeding Frederick H. Eaton. Mr. Woodin received a technical education at Columbia University School of Mines. He worked his way through the shops of the Jackson & Woodin Manufacturing Company, Berwick, Pa., which company had been established by his grandfather in 1842, and was one of the companies amalgamated with the American Car & Foundry Company at the time of that company's organization. In 1892 he had become general superintendent of the Jackson & Woodin Manufacturing Company, and continued as such until 1895. From 1895 to 1899 he was vice-president, and in 1899 when the American Car & Foundry Company was formed, became district manager of the Berwick plant, the largest car building plant in the country. Since 1902 Mr. Woodin has been a director and assistant to president of the American Car & Foundry Company.



W. H. Woodin

A. W. Wheatley, vice-president and general manager of the Canadian Locomotive Company, Ltd., Kingston, Ont., has been elected president of the Lima Locomotive Corporation, at Lima, Ohio. Mr. Wheatley was born at Ashford, Kent county, England, October 12, 1870. At the age of 15 he became a rivet boy in the shops of the South Eastern Railroad, and in 1887 apprenticed himself as a machinist, attending the night school conducted by the railroad. In 1892 he came to America, finding employment on the Northern Pacific at Brainerd, Minn., as a machinist. In 1893 he was transferred to Staples, Minn., in the same position. In 1895 he was made foreman, occupying that position until 1900. He was transferred to Livingston, Mont., as general foreman in December, 1902, and later was made master mechanic of the Yellowstone divi-



A. W. Wheatley

sion, with headquarters at Glendive, Mont. In June, 1903, he was appointed shop superintendent at Brainerd, becoming in April, 1904, general master mechanic of the entire Northern Pacific system. In February, 1905, he accepted a position on the Rock Island as shop superintendent at Moline, Ill., leaving one year later to become assistant superintendent of motive power of the Union Pacific, with headquarters at Omaha. In June, 1907, he left railway service and entered the employ of the American Locomotive Company at Schenectady as general inspector. In December of the same year he was transferred to Montreal as manager of the Montreal Locomotive Works. In November, 1910, he was placed in charge of the Dunkirk plant, but in June, 1911, left to accept the position of vice-president and general manager of the Canadian Locomotive Company, Ltd.

The Locomotive Feed Water Heater Company, 30 Church street, New York, has been organized with a capital stock of \$1,000,000 and with the following incorporators: George M. Basford, Samuel G. Allen, E. A. Averill, H. F. Ball, Luther D. Lovekin, Joel S. Coffin, LeGrand Parish, J. E. Muhlfield, George L. Bourne and V. Z. Caracristi. This company will develop and handle for locomotive use the film heater designed and patented by Luther D. Lovekin, chief engineer of the New York Ship Building Company. The officers of the company are: President, George M. Basford; vice-president, E. A. Averill. Mr. Basford will also form the G. M. Basford Company to handle the advertising accounts of a number of railway supply concerns.

George M. Basford is now chief engineer of the railroad department of Joseph T. Ryerson & Son and will sever his connection with that company on March 15 to take up his new work. Mr. Basford was born in Boston in 1865, where he attended the public schools. He was graduated from the Massachusetts Institute of Technology in 1889, after which he entered the Charlestown shops of the Boston & Maine, later going to the Chicago, Burlington & Quincy as a draftsman at Aurora, Ill. He left the Burlington to take a position in the motive power department of the Union Pacific and was connected with the test department of that road for some time, after which he entered the service of the Chicago, Milwaukee & St. Paul as signal engineer. Later he was superintendent of construction of the Johnson Railway Signal Company, was with the Union Switch & Signal Company for a short time, and then became signal engineer of the Hall Signal Company. In 1895 he became mechanical department editor of the *Railway and Engineering Review*, and in 1897 was made editor of the *American Engineer and Railroad Journal* when that publication was owned by R. M. Van Arsdale. In September, 1905, he was made assistant to the president of the American Locomotive Company and in March, 1913, became chief engineer of the railroad department of Joseph T. Ryerson & Son.

Mr. Basford was one of the founders of the Railway Signal Association and has been known as the father of that organization. He has been closely identified with the development of the locomotive in this country and is also noted



G. M. Basford

because of the inspiration and assistance which he has given not only in developing rational apprenticeship courses for mechanics in the motive power department, but in the efforts which he has made to awaken railway officers generally to the necessity for giving more attention to the selection, training and promotion of employees. His work with the American Locomotive Company was notable among other things for the development of the publicity campaign of that company which has been an important factor in awakening railway supply manufacturers to the possibilities of advertising. During the early stages of the development of the Railway Business Association in the winter of 1908-9 arrangements were made with the American Locomotive Company whereby Mr. Basford gave part of his time to that association as secretary. A more complete sketch of Mr. Basford's career will be found in the *American Engineer* of April, 1913, page 225.

E. A. Averill was born at Richland, N. Y., August 13, 1878, and after a preparatory education in public and private schools entered Cornell University in 1896. He was graduated in 1900 with the degree of mechanical engineer and specialized in railway mechanical engineering during his senior year. The summer of 1899 he spent in the shops of the Philadelphia & Reading, Reading, Pa., and after graduation went into the shops of the Chicago, Burlington & Quincy at West Burlington, Iowa. After four years' service with the Burlington, the greater part of which was spent in shop and roundhouse work and on the road, Mr. Averill joined the staff of the *Railway and Engineering Review* of Chicago.

On January 1, 1906, he joined the editorial staff of the *American Engineer and Railroad Journal*, and on April 1, 1910, became managing editor of that publication. On March 1, 1914, he was made engineer of operation of the Standard Stoker Company, with which company he has been connected until recently.

George L. Wall, vice-president and manager of the Lima Locomotive Corporation, has resigned and taken an office at room 219, Opera House block, Lima, Ohio.

H. K. Porter, formerly southern sales agent with office at Atlanta, Ga., for the U. S. Metal & Manufacturing Company, of New York, has accepted a position with the Hyatt Roller Bearing Company, of Newark, N. J.

Watson H. Linburg, president of the United & Globe Rubber Manufacturing Companies, Trenton, N. J., died on January 6. Mr. Linburg was one of the pioneers in the manufacture of air-brake hose and other mechanical rubber goods used by the railroads.

Frank Snyder, general superintendent of the Mt. Vernon Car Manufacturing Company, Mt. Vernon, Ill., died at his home in that city on Wednesday, February 2, after an illness of about ten days. Mr. Snyder had been general superintendent of the company ever since its organization 26 years ago.

The American Car & Ship Hardware Manufacturing Company, New Castle, Pa., has changed its name to the Johnson Bronze Company. The change in name has been made solely for the convenience of the company's customers; there will be no change in the policy or personnel of the company. The



E. A. Averill

officers of the Johnson Bronze Company are C. H. Johnson, president; T. H. Hartman, secretary and treasurer, and P. J. Flaherty, general manager.

Samuel G. Allen has been elected president of the Franklin Railway Supply Company, New York, and Joel S. Coffin, formerly president, is now chairman of the board.

Mr. Allen has served as vice-president since the incorporation of the company. He was born in 1870 at Warren, Pa., and was educated there and at the Pennsylvania State College. He was plunged into business responsibilities immediately after leaving college, but nevertheless found time to study law during a period of intense business activity. He was admitted to the bar in Warren county, Pa., and practiced law for nine years. In 1901 the Franklin Railway Supply Company was

formed, with Mr. Coffin as president and Mr. Allen as vice-president. The ability of Mr. Allen as a lawyer and as a business man is reflected in the success of the large number of companies with which he is connected as an officer and director.

Frederick Heber Eaton, president of the American Car & Foundry Company and chairman of its executive committee since June, 1901, died at his residence in New York City, January 28. Mr. Eaton had been a commanding figure in the car manufacturing industry for many years. He was born at Berwick, Pa., April 15, 1863. He obtained his early business experience as chief clerk in the office of the Berwick Rolling Mill Company, then a subsidiary of the old Jackson & Woodin Manufacturing Company. From 1892 to 1899 he was successively secretary, vice-president and president of the Jackson & Woodin Company at Berwick. In 1899 he was an important factor in the formation of the American Car & Foundry Company and was chosen for the position of first vice-president. In June, 1901, he succeeded to the presidency and to the chairmanship of the executive committee, which office he continuously held until his death on January 28. Mr. Eaton was also chairman of the board of the American Car & Foundry Export Company.

Charles A. Liddle, newly elected vice-president, and D. A. Crawford, newly elected treasurer of the Haskell & Barker Car Company, have also been elected directors of the company.

Patrick J. Carroll, president of the Bucyrus Steel Castings Company, the Ohio Locomotive Crane Company and the Carroll Foundry & Machine Company, Bucyrus, Ohio, died on January 20 at the age of 55 years.

F. V. Roy, heretofore manager of the railway supplies department of Fairbanks, Morse & Co., Chicago, has been appointed manager of the company's Omaha house. E. E. Pendray, heretofore representing the company in Texas territory, has been appointed manager of the railway supplies department, with headquarters at St. Louis. C. N. Wilson, representative on the St. Louis lines, has been transferred to the Texas territory, with headquarters at Houston, Tex.

B. B. Jones, of Oklahoma City, Okla., formerly with the Illinois Central at McComb, Miss., has been elected president of the O'Malley-Bear Valve Company, Railway Exchange, Chicago, succeeding R. L. Beare. The following men have been added to the sales force of the company: W. M. Leighton, formerly with the Paxton & Mitchell Company, Omaha, Neb.; H. M. Newell, formerly with the H. W. Johnson-Manville Company; Blake C. Hooper, formerly with the Grip Nut Company, and J. N. Gallagher, formerly foreman of the boiler shops of the Illinois Central at Birmingham, Ala.

Henry Lee, secretary and treasurer of the Simmons-Boardman Publishing Company, publishers of the *Railway Age Gazette*, the *Railway Mechanical Engineer*, the *Railway Signal Engineer* and the *Railway Electrical Engineer*, has been elected a vice-president. Mr. Lee's entire business career has been spent with the *Railway Age Gazette* and *The Railway Age*. He was born at Hamlet, Ill., on May 25, 1884, and was educated in the common schools at Hamlet, and the high school at Aledo, Ill. In 1905, he graduated from a business college in Chicago, and on June 6 of that year joined the staff of *The Railway Age* as assistant to the business manager. In December, 1906, he was assigned to the news staff, and in September of the following year became an associate editor and was transferred to New York. When, in June, 1908, the *Railroad Gazette* and *The Railway Age* were consolidated and became the *Railway Age Gazette*, he was transferred back to Chicago, but in April, 1909, he returned to New York, where he entered the business department and was placed in charge of the advertising make-up desk. About November, 1909, he was given charge of writing advertising copy, and thus founded the copy-service department of the publication. He was shortly afterwards made one of the paper's representatives in the trade, and in March, 1910, was made secretary. In February, 1911, he was also elected treasurer and in June, 1912, became a director. Mr. Lee has taken an active part in the publishers' organizations devoted to technical and trade papers. In 1911-12 he was secretary and treasurer of the Federation of Trade Press Associations of the United States, and in January of this year was elected secretary of the New York Trade Press Association. As vice-president of the Simmons-Boardman Publishing Company he will also continue as treasurer of the company.



S. G. Allen



F. H. Eaton



Henry Lee

## CATALOGUES

**SAND BLASTS.**—Bulletin No. 531, recently issued by the Pangborn Corporation, Hagerstown, Md., is a leaflet illustrating and describing the company's type "L. A." rotary table sand blast.

**ENGINES AND PUMPS FOR OIL.**—Bulletin No. 9, recently issued by the National Transit Pipe & Machine Company, Oil City, Pa., is devoted to the company's foam system for extinguishing oil fires.

**PIPE.**—The American Spiral Pipe Works, Chicago, has issued Bulletin 15-9, descriptive of its line of lap welded pipe. The booklet contains a large number of views of pipe supplied for various installations.

**PNEUMATIC TOOLS.**—The Chicago Pneumatic Tool Company has recently issued Bulletin No. 34-K relative to the class N-SO fuel oil driven compressors and their application to the unit system of air power plants.

**MACHINE TOOLS.**—Bulletin No. 1013 recently issued by the Reliance Electric & Engineering Company, Cleveland, Ohio, gives a description and specifications of the Reliance type ASL, form A all-gear motor drive for application to cone-pulley lathes.

**TURBINES.**—"The Terry Turbine" is the title of a new bulletin just issued by the Terry Steam Turbine Company, Hartford, Conn., giving a general description of the various turbine applications, and dealing particularly with various kinds of high, low and mixed pressure turbines.

**A RAILWAY CRANE.**—The Bucyrus Company, South Milwaukee, Wis., has issued an eight-page pamphlet, describing its Class 150-17 crane for wrecking and other railway purposes. This pamphlet gives the details of its construction and operation and is illustrated with numerous photographs.

**MACHINE TOOLS.**—The Covington Machine Company, Covington, Va., has recently issued bulletin No. 11, containing a number of illustrations of Covington punches, shears, bending rolls, etc., for all classes of service. The sole agent in the United States for these machines is Manning, Maxwell & Moore, Inc., New York.

**POWER HAMMERS.**—A booklet recently issued by Beaudry & Co., Inc., Boston, Mass., describes and illustrates the company's line of Champion and Peerless power hammers. The various types of hammers are described in some detail and information is given concerning the kind of work for which each hammer is best fitted.

**BULB SECTIONS.**—The Carnegie Steel Company, Pittsburgh, has issued a pamphlet containing tables and data on all the sections which they now roll in bulb angles and bulb beams. This is in response to an increased demand for this class of material for use in steel car construction, and particularly for steel ship building in the United States and elsewhere.

**PORTABLE ACETYLENE LIGHTS.**—The Alexander Milburn Company, Baltimore, Md., has recently issued a 52-page booklet describing and illustrating its line of Milburn lights for all kinds of service. The booklet explains for what service each light is intended, shows typical illustrations, explains the construction, and shows the methods of operating the lights. Several pages are devoted to letters from railways and other companies who have used the lights and have found them of value.

**PIPE SPECIALTIES.**—The National Tube Company is issuing a very attractive booklet entitled: The Whole "Kewanee" Family. The booklet in its 72 pages illustrates and describes the Kewanee union (the "father" of the family) in its various forms, and the other Kewanee specialties such as the N. T. C.

regrinding valves, National service cocks, etc. On page 60 there is a complete list of the Kewanee specialties, and on pages 39 to 47 are given instances of satisfactory uses of Kewanee unions and specialties.

**FILING CABINETS.**—The Yawman & Erbe Manufacturing Company, Rochester, N. Y., has recently issued a booklet entitled "The Proper Place for Blue-Prints and Drawings" emphasizing the necessity for adequate filing systems for the drafting room and detailing the advantages of the Mammoth Vertical File made by the company for blue-prints and other drawings.

**LOCOMOTIVES.**—Bulletin No. 1, recently issued by the Lima Locomotive Corporation, contains illustrations and general descriptions of a number of locomotives which the company has built for representative railroads. Included are the Erie, Pacific, Mikado and six-wheel switching locomotives, a Duluth & Iron Range Mikado locomotive, a Pennsylvania Lines West six-wheel switching locomotive, a Lackawanna eight-wheel switching locomotive and others.

**ACETYLENE.**—The Searchlight Company, Chicago, has issued a pamphlet entitled "The Searchlight Treatise on Acetylene." It contains 12 pages, briefly describing the development of the use of the oxyacetylene process for welding and cutting, and discusses at some length the commercializing of the gases, in which the method of preparing, purifying and handling acetylene in cylinders is considered. There is also a brief discussion regarding the use of acetylene generated by small generators at the plant vs. the cylinder acetylene.

**ROTARY PLANING MACHINE.**—The Newton Machine Tool Works, Philadelphia, Pa., have recently issued Catalogue No. 50, describing their rotary planing machines or girder ending and facing machines. The catalogue gives a general description of these machines, together with a copy of the general specifications, including illustrations of the various types with their general dimensions. Various other illustrations are included which show the Newton rotary planing machines installed in various shops throughout the country.

**THREADING MACHINERY.**—The 1916 catalogue of the Landis Machine Company, Inc., Waynesboro, Pa., catalogue No. 22, illustrates in its seventy-eight pages, the line of threading machinery made by the company. The booklet contains some exceptionally good photographs of the various kinds of bolt threading, bolt pointing, nut tapping, pipe threading and cutting machines, screw cutting die heads, chaser grinders, etc., and there are also given specifications, list prices, code words, etc., as well as descriptions of the machines and information as to the kind of work for which each is best adapted.

**WEIGHING COAL AND WATER IN POWER PLANTS.**—Bulletin No. 101 of the Richardson Scale Company, Passaic, N. J., issued under date of January, 1916, bears the title "Automatic Weighing of Coal and Water in Power Plants." The book, which is attractively illustrated and well printed, emphasizes the advantages of weighing coal and water automatically in power plants, and aims to show, with the aid of half-tones and line drawings, the excellencies of the equipment which this company makes for this purpose. The scales are described in detail, and a large number of the illustrations show typical installations.

**CORK INSULATION.**—The Armstrong Cork & Insulation Company, Pittsburgh, Pa., has issued a 152-page book, describing its Nonpareil corkboard insulation. This book, which is prepared in an attractive manner, describes briefly the preparation of cork and more in detail the merits of this material for different purposes and tests to which it has been subjected. Nearly one-half the book is devoted to specifications covering the methods of erecting Nonpareil corkboard for a wide variety of conditions. The book is well illustrated with photographs of typical installations of this material.

# Railway Mechanical Engineer

Volume 90

April, 1916

No. 4

## How Can the Car Designer Improve?

It is not unusual to hear the car designer severely criticized by those who have to do with the maintenance of cars or their use in service. Some classes of equipment spend too much time on the repair track, others may be too heavy in comparison with the revenue load which they will carry to be satisfactory to the operating department. Sometimes the cost of repairs could have been reduced if certain details had been a little differently arranged. In what way do you think the car designer can improve these conditions? Do you think there is a sufficiently close relationship between the drafting room and the departments using and repairing the cars? Do the assumptions upon which the design for strength is based approach sufficiently close to actual service conditions to be reliable? We will award prizes of \$10 each for the three best letters discussing any one or all of these questions, or offering any suggestions as to how the car designer can make his work more effective. These letters should not exceed 1,000 words each and must be received at our office, Woolworth Building, New York, not later than June 1, 1916. They will be judged entirely upon the merits of the practical suggestions offered.

## What is Heat-Treated Steel?

On page 111 of the March number we announced a competition on heat-treated steel, what it is and how it should be handled. This is an opportunity for the man who is familiar with the practices connected with the preparation of this material to tell what he knows for the benefit of the man who has not been able to familiarize himself with them. Modern locomotive design necessitates the use of special materials in order to obtain both lightness and strength and heat-treated steel is coming to the front as a material which will meet these requirements. It follows naturally that railway mechanical men in general and smith shop foremen in particular, must know considerable about its characteristics if they are to have the desired success in repair work where heat-treated steel is concerned. For the two best articles on this subject we will give a first prize of \$35 and a second prize of \$25, the articles to be judged from a practical standpoint. They must be received in our offices in the Woolworth Building, New York, on or before May 1, 1916. For other articles which are accepted for publication we will pay at our regular space rates.

## The Apprentice Competition

Thirty-seven letters were received in the competition for apprentices, in which they were urged to make practical suggestions as to the value of the efforts which were being made to train and educate them and as to how in their opinion these methods could be improved. The first prize of \$15 has been awarded to J. C. Bowman, an apprentice at the Av's shops of the New York Central at Jersey Shore, Pa. The second prize of \$10 has been

awarded to E. C. Crawford, a machinist apprentice at the Drifton, Pa., shops of the Lehigh Valley Coal Company. Of the 37 contributions, 27 were received from the apprentices of the Lehigh Valley Coal Company at Drifton, Pa. Undoubtedly this is due to the interest which the superintendent of the shops, J. Campbell, took in a competition last fall on "How Can You Help the Apprentice?" Mr. Campbell's article was published on page 531 of the October, 1915, issue. Of the 10 other contributions four were received from apprentices on the Santa Fe and two from apprentices on the New York Central. Both of these roads have given more than ordinary attention to modern apprenticeship methods. The Baltimore & Ohio, Canadian Pacific, Erie and Southern Railway were each represented by a contributor. Several of the contributions are published on another page of this issue and contain excellent suggestions which are well worth thoughtful consideration on the part of those who have to deal with the apprentice question.

## Shop Improvement Committee

For the purpose of developing more efficient methods in the repairs of cars and locomotives, some railways have formed shop improvement committees, which make a study of shop practices in the various shops of their own roads and in some noteworthy shops on other roads. The results of these studies have always been satisfactory and conditions have been so improved as to cause marked increases in efficiency. It is a splendid practice to adopt and to follow out carefully. Conditions are always changing, and new ideas are being developed constantly. On large roads especially, it is important that the various shops be in close touch with one another. There are certain standard jobs done in every shop, the cost for which should be carefully watched and compared with the cost in the other shops of the system. If one shop is doing better than another, an analysis will show where the less efficient shop can be improved. It may be that the equipment is lacking, or that the men are not properly instructed. In the first case it might prove expedient to provide better equipment, and in the second case direct steps should be taken to properly educate the men. The best results will be obtained if the improvement work be under the direct charge of an efficient demonstrator. The exchange of ideas by correspondence is weak, in that the personal element is always lacking. A workman *shows* how to do a certain job is always more responsive than if he were *told* how to do it.

## Reducing Weight in Car Design

A good many of the designs of steel freight equipment have been put into service so quickly, at a time of equipment shortage, that the designers did not have the opportunity to do their most effective work in the way of reducing the weight to a point as low as possible consistent with strength. There is so much variation in the weights of cars of the same capacity, but of different design, that it is impossible to avoid the conclusion that

much could be gained by a more effective distribution of the material in some of these designs. Of course, some of the older designs have shown up badly as regards strength, even though comparatively heavy, but it seems to us that this only strengthens the argument that the disposal of the metal was not the best possible. The steel car designer has accomplished a great deal in producing the equipment that is now in service, but we believe that there is still more to accomplish along much the same lines as those that have been adopted in recent years by locomotive designers, in tending toward refinement rather than merely toward size in producing capacity. What can be accomplished in the way of steel car design is evidenced by the 90-ton gondola cars, large numbers of which are in regular service on the Norfolk & Western. These cars weigh 59,000 lb. and it is worthy of special note that in the latest design this weight has been reduced practically 6,000 lb. and it is believed that the strength has not been impaired. When it is considered that these cars are mounted on six-wheel trucks we feel that there lies in this work of the Norfolk & Western mechanical department a subject for careful consideration by car designers in general.

#### Lost Motion in the Roundhouse

The apparent confusion with which the work of a large roundhouse is conducted is familiar to all who have occasion to visit engine terminals, especially if they attempt to locate any individual member of the force. The way in which the men are scattered throughout the house and the long trips necessary to secure material or tools are usually considered a necessary part of the conduct of the work. That much time can be lost where gangs are scattered throughout the house cannot be denied, the loss being accepted as necessary to secure the benefits of an organization of specialists, assigned to each class of work. At an engine terminal handling about 125 engines daily a plan has recently been worked out whereby the roundhouse is divided into sections of six stalls each. Each section is in charge of a gang leader whose gang is permanently organized to take care of all classes of work. No one is expected to or is permitted to leave the section of the roundhouse to which he is assigned, each gang being provided with its own set of tools. A handy man or laborer sufficiently familiar with the work to know material and tools is despatched to the tool room when special tools are required, and secures all material required from the store room. He also is expected to make the necessary trips to the blacksmith or machine shops. By having every mechanic assigned to work within a comparatively limited space the opportunity for lost motion should be materially reduced, and the ability to properly check up the force is greatly increased.

#### Developing the Apprentice

The practice recently adopted by the Atchison, Topeka & Santa Fe of sending some of its senior apprentices to the Baldwin Locomotive Works and to the Pullman Company, for experience, is deserving of more than passing notice. The Santa Fe is a road that thoroughly believes in developing its shop men from apprentices. It has the most extensive and well-developed apprenticeship system of any road in this country. It believes in developing the apprentice to the highest possible degree, and in order that the boys may learn still more than the Santa Fe can teach them, arrangements have been made with locomotive and car works, as indicated above, so that a few of the most apt and capable apprentices can enter these plants, work in their shops and study their organization and methods. Needless to say these boys, fresh from the hands of the apprentice instructor, will have their eyes open and their wits at work, noting how work is performed and how men are handled in

shops other than their own. These boys are employed as sub-foremen, so that they have some responsibility and yet receive proper guidance. Undoubtedly, the time they spend in these temporary positions will be valuable to the apprentices themselves and to the Santa Fe when they return to that road. They will have passed their "cub" days as foremen; they will have been put through their "course of sprouts" among strangers and will come back to their road better able to govern the men who were once their bench mates. Their bashfulness and diffidence will have disappeared. They will have better control of the men, and in view of their experiences in these other plants the men will have greater respect for them.

#### Costs Needed in Reclamation Work

Reclaiming material from the scrap pile has become so common on the railways of this country that we believe it would be well to repeat a word or two of caution that we have uttered once or twice previously. Some of the so-called "reclamation work" is not reclamation. There are railway officers who are carrying out some branches of this work about which they are simply deluding themselves as regards savings. It is believed that this is mainly due to the failure to take into account the actual cost of everything concerned in the reclaiming. As a general consideration no branch of this work should be continued unless it is shown plainly that it is being conducted at a profit. It is quite within the bounds of possibility that material may bring a greater return to the company if sold as scrap than if it is put through the reclaiming plant and returned to service, and there is material being reclaimed that cannot be used again. Some roads have gone to the trouble to cut up old boilers with the oxy-acetylene torch in order to get higher scrap prices. We were told recently by the officers of a road that had tried this that it had been abandoned because after a thorough investigation it was found that it did not pay. We believe there are a great many roads which could conduct an investigation of this kind on some of their reclamation work to advantage to themselves, as there is no question that some of this work as it is being carried out is not profitable. We do not by any means intend to reflect on the value of reclamation work as a whole, nor upon the moral effect which it has on railway employees toward the prevention of waste, but we do feel that the test "Does it pay?" should be applied in every case.

#### The Expense of Poor Repair Facilities

"That engine has been in service 18 months; she is just falling to pieces, but I can't get her in the shop." It is nothing uncommon to hear a master mechanic make a statement of this character. There are large locomotives in great number that have been in service for long periods without any repairs other than those which could be given them at the engine terminal, itself inadequately manned and equipped. It is expensive to operate locomotives in this way; the cost of terminal repairs is increased, coal consumption is increased and there are more engine failures. The cause of this condition is the purchase in large numbers of locomotives of a size and type far beyond the capacity of the repair facilities on the road. Undoubtedly it is a difficult condition to control. In many instances, competing lines have large power and consequently high train load and if this competition is to be met, large power is essential. But poor judgment seems to be displayed at times in apportioning the money that is to be spent. A road that has small power, and shop and engine facilities in keeping with it, might better spend part of an appropriation for large locomotives on modern machinery and buildings than to put the entire amount into locomotives without any additional



facilities. With the same amount expended in both cases, we believe that the fewer number of locomotives properly maintained will take care of as much business as a larger number where the maintenance work is neglected. Locomotives have got to be repaired sooner or later and when the shops are too small or too poorly equipped to take care of the repairs at the time they are needed the large locomotives are invariably taken out of service and have to spend weeks and months awaiting their turn in the shop. Considering the cost of present day locomotives and the amount of money tied up when they are kept idle, their purchase without provision being made for effective maintenance would seem to be expensive economy.

**Constructive Methods in Re-organization**

A new officer is very seldom entirely satisfied with the organization of his predecessor. Very often he starts in almost immediately to make changes, some of which are ill-advised and result in trouble for him later. The changes made in instances of this kind too often give the impression that they are being made in order to give the appearance of making a showing. Of course, there are cases where an organization has become so demoralized that nothing but radical action will remedy matters, but we believe that in the majority of instances the desired results can be obtained without the wholesale discharging and transferring that seems to be so common. An example of what can be accomplished by constructive rather than destructive methods came to our notice recently. A young man was placed in charge of the repair work at a large terminal. The man who preceded him had held the position for many years and during the latter part of his foremanship had fallen into rather shiftless ways, with the result that those under him had begun to encroach on his authority and there was considerable disaffection. The newcomer was a man of ability and possessed of a nature which would not tolerate some of the practices which he found in effect. Several of the minor officers predicted his speedy downfall and one in particular announced his intention to "get" the new man. The foreman looked into matters very carefully and was strongly tempted to discharge this man and several others, but after thinking the matter over he decided against this. Instead he left the organization exactly as it was except for some minor changes and proceeded pleasantly but firmly to show all concerned that he was in charge, that he knew his business and intended to remain in charge. Within two months he had the terminal so improved that the changes were commented upon by the general officers of the road and the man who at the start was apparently his worst enemy was now his staunchest supporter. We cite this example merely to show that fire-eating methods are not always necessary in cases of this kind, and if they are not necessary they are certainly not desirable.

**Periodical Appropriations for Material**

Most railways employ a system of periodical appropriations for labor, and officers of the mechanical department are generally familiar with the way men are laid off and working hours are cut at the end of the month to insure the expenditures falling within the appropriated amount. The material used in the conduct of railway operations is expensive and is rapidly growing more so. It costs a railway a great deal of money to have unused material lying around the various shops and engine-houses. There are always more or less vigorous steps taken to prevent the waste of material, but they are often inconsistent, and in spite of them a great deal is wasted and a great deal is charged out and then lies unused. If periodical appropriations were extended to cover material as well as labor we believe that it would not only result in a marked re-

duction in the amount of material carried in this way, but would also greatly facilitate the work of maintenance of equipment by increasing the flexibility of appropriations, because a master mechanic or foreman could then so adjust his work in many instances as to save on expenditures for material and use the saving as an expenditure for labor. Of course, the supply department would have to co-operate to the greatest degree with the mechanical department, and the latter would have to be kept advised at all times of their total expenditure to date. A system of this kind is being employed on the Seaboard Air Line and its success is attested by officers of the mechanical department. By a very slight expenditure, the supply department keeps such a record of material used that the mechanical department can find out at any time what the expenditure is and a periodical report of material expenditures is furnished to the mechanical department and is in the hands of the officer concerned within two days of the close of the period. It will be recognized at once that the success of any system of this kind depends largely on the supply department keeping its records always up-to-date, as if the information regarding the material used is to be of any use it must be available when it is wanted. This practice has apparently been worked out with such simplicity and at the same time so effectively on the Seaboard that it seems strange that it has not been employed elsewhere.

#### NEW BOOKS

*Proceedings of the Traveling Engineers' Association.*—Bound in leather. 329 pages, 5½ in. by 8½ in. Published by the association, W. O. Thompson, secretary, New York Central Railroad, Cleveland, Ohio.

This is the proceedings of the twenty-third annual convention of the association held in Chicago, September, 1915. The subjects covered include: The effect of lubricating and mechanical firing on locomotive operating costs; recommended practice for employing and training new firemen; smoke prevention; advantages of superheaters, brick arches, etc.; improving the handling of air brakes; the electro-pneumatic brake; valve gear and its relation to fuel economy and operating costs; scientific train loading.

*Locomotive Engine Running and Management.*—By Angus Sinclair. Bound in cloth. 428 pages, 5 in. by 7½ in. Illustrated. Published by John Wiley & Sons, Inc., New York. Price \$2.

This is the twenty-third edition of a book which has been most favorably known in railroad circles since 1885. There are many successful railroad men who obtained their first knowledge of the locomotive and its management from this book and it is a most valuable work for anyone concerned in the operation of locomotives. In this edition the book has been thoroughly revised and brought up to date and the author states that it is now practically a new book. The changes in air brake apparatus have been covered and a section on electric locomotives has been added.

*The Mechanical Engineers' Pocket-Book.*—By William Kent, M.E., Sc.D. Bound in leather, 1477 pages, 4 in. by 6¾ in. Illustrated and indexed. Ninth edition, revised and enlarged. Published by John Wiley & Sons, Inc., New York. Price \$5.

This reference book is so well and favorably known among engineers that it scarcely needs any special notice. In this, the ninth edition, the work has been thoroughly revised with the assistance of Robert Thurston Kent, M. E., consulting engineer. Extensive revisions have been made in the subjects of materials, mechanics, fans and blowers, heating and ventilation, fuel, steam boilers and engines and steam turbines. The new matter includes much data on such subjects as planing, milling, drilling and grinding and the chapter on machine shop practice has been rewritten and doubled in size. The matter pertaining to electrical engineering has been completely rewritten and brought into agreement with present practice, and many new tables have been added.

### COMMUNICATIONS THE MECHANICAL DEPARTMENT CLERK

CHICAGO, Ill.

TO THE EDITOR:

I am a mechanical department clerk—a chief clerk, to be exact—and am therefore one of the "crowd of competent and incompetent men—usually in blind-alley jobs, with no training and no outlook."\*

The mechanical department clerk is, in a sense, in a blind alley. He cannot succeed to the position of general foreman, master mechanic or superintendent of motive power. You ask why any of us start to work in this capacity in a department where there is so little opportunity ahead, and why we stay in it. For numerous reasons. In the first place, we may have undertaken the work at an age when we could not understand the real state of affairs and our parents were unable to advise us correctly. As one of the correspondents in the Railway Age Gazette has suggested, "The average young fellow when he leaves school wants to get into an office because he can be dressed up."

Why do we stick? Because by the time we can think for ourselves we are probably getting \$65 or \$75 a month, have a "best girl" to entertain, and do not have the courage or inclination to start in another line of business at lower wages.

I worked my way through various positions to that of chief clerk in the office of the leading master mechanic on the system and am receiving the highest salary paid to a master mechanic's chief clerk. If I resign this position, where shall I go to find a better one? Shall I aspire to be chief clerk to the superintendent of motive power? If so, how about the assistant chief clerk and others in the superintendent of motive power's office who are earnestly striving for advancement? If I should be successful in obtaining that position, where shall I turn next? The transportation department appears to be the most logical course, since clerks in that department are sometimes promoted to the position of trainmaster. It is necessary, however, if I wish to enter that department, to work up from the bottom. This I cannot do because I have a family to support.

If there is any department on a railroad where the efforts of a clerk are less appreciated than in the mechanical department, I should like to know it. The men holding official positions in this department usually advance from the shops and are purely and simply practical men. As a rule they fitted themselves for their positions not by technical training, but by having made good in shop work. They must be supported by an efficient office force.

Listen to the remark made by a "boss" who took a lively interest in the welfare of one of the office boys and was advising him to go into the shops and learn a trade. He said, "Young man, do you want to stay in an office all of your life, or would you like to get into the shops and make something of yourself?" This is typical of the men above us in the mechanical department.

Accompanying this letter is a chart which illustrates the comparative progress of a mechanical department clerk and a machinist apprentice. The heavy dotted line shows the progress of the average railroad clerk; the lighter dotted line shows the progress of a fortunate or exceptional clerk. The heavy continuous line shows the progress made by the average apprentice, and the lighter one that of an exceptional or more fortunate apprentice.

The average clerk is, in general, and must be, superior to the average apprentice in knowledge and mental training; but what is the reward? (Study the chart. It was not made up after a moment's thought, but reflects true conditions.) The apprentice, after serving four years, automatically be-

comes a journeyman machinist and is entitled to the standard wage. Ninety-eight per cent. of the graduate apprentices qualify. They join a union, which insures them a living wage and recourse in case of sharp practice. With them it is a case of "if you don't like your job, quit," and they can always command a salary sufficient to meet living expenses. The clerk advances slowly as vacancies occur, but does not command a salary and enjoys no feeling of independence.

Suppose the clerk should finally reach the position of chief clerk. The master mechanic leaves and the position is filled by the transfer of another master mechanic from a smaller point. The new incumbent follows the line of least resistance. His former chief clerk satisfied him and was familiar with his personality, requirements, etc. It is too much of an effort to break in the present chief clerk to meet his wishes and he finds a reason to let him go, or demote him. And what recourse has the chief clerk or any other clerk?

In the Railway Age Gazette of September 3, 1915, Homer Pigeon, in an article entitled "The Unnoticed Unorganized Employee," had the following to say concerning train dispatchers (the statement is equally true of clerks): "There

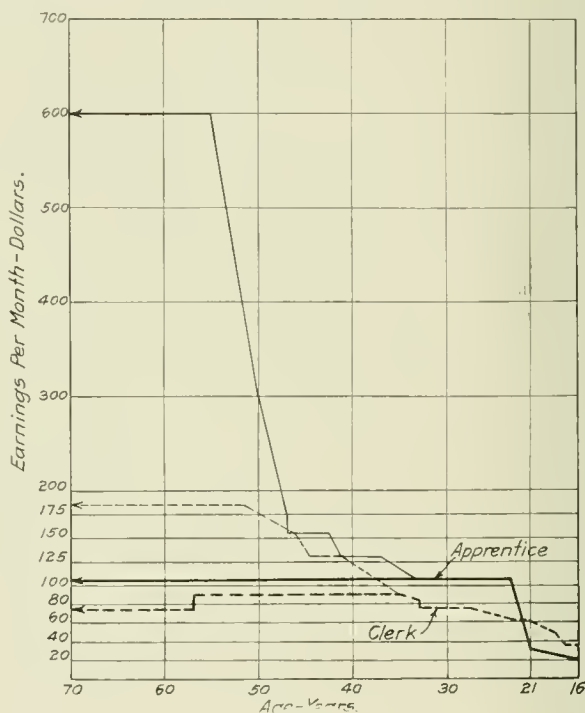

Comparison of the Earnings of the Clerk and the Apprentice

are many other ways in which railway companies can serve their own interests by devoting a little thought to the welfare of those employees who do not belong to a fraternal order. I hope to live long enough to see some of them put into operation. If I do not, I know that I shall live—if the life insurance companies guess correctly as to my prospects—to see many more men driven into organization in self defense."

R. V. Cooke takes equally as strong a position on the other side of the question in a letter in the Railway Age Gazette of December 24, 1915: "Again, organization of all branches of clerks would not be fair to the companies that employ us. We, through the very nature of our positions, handle some of the most confidential affairs of the company, and, as we are but human, who among us could keep from using this information to our advantage if we owed allegiance to an outside organization? Loyalty to the company is nothing more than is due. I believe that a railroad clerk must not affiliate with a labor organization; but it looks as though the danger suggested by Homer Pigeon will develop unless something is done to better the conditions of the average clerk.

A. C. CLERK.

\*This quotation is taken from an address by George M. Basford before the Burlington Association of Operating Officers, the exact quotation reading: "Clerks are a crowd of competent and incompetent men—usually in blind-alley jobs, with no training and no outlook." The address in full appeared in the Railway Age Gazette of July 23, 1915, page 150.



## Which is Most Worth While?

BY HARVEY DE WITT WOLCOMB

In these days, when the study of reclaiming scrap for nearly all classes of material used by the railroads has reached the point where phenomenal records are being made, it is surprising that more attention is not given to better utilization of the older employees.

At first thought, it may appear inhuman to ask and expect any regular assigned tasks from an old employee that has worked hard all his life in the company's service; yet we only have to follow up the history of some one of the many engineers who are taken out of active service at the age of 70 years, and who are apparently in the best of good health, and see how quickly they either break down or die after being placed on the pension list. Or take an active shop man and see how quickly he ages after he is taken out of the shop and is required to stay at home with nothing on his mind to think about. There is really a humane side to the question of providing some agreeable occupation for the old employee, and in the meantime the company can receive some small returns if the problem is given proper consideration.

### OLDER MEN MORE ACCURATE

There is a certain fascination in working for a railroad that holds a workman, even if higher wages can be secured from neighboring concerns, and one of the strongest factors of this fascination is the thought that when he has grown old and feeble he will be given something to do that will keep his name on the pay roll. For a man who has had active service to be given some light task for which there is no responsibility or action required, is both harmful to the man and to the company. Even if the man is old and feeble, he still retains his keen mental abilities and is well able to see and do certain things better than some untrained young man just starting out in life. A typical example of this kind was forcefully brought out in looking over a large office of clerks, where a reorganization had just been made and new clerks employed in order to increase the efficiency. The chief clerk was asked if the results were satisfactory. His reply was that the new clerks were quick, but if he desired some specially accurate report, he usually gave it to one of the older clerks who had been in the office over 30 years. While the older clerk could not compete with the speed of the younger men, he still held a very important place in the office because of his accuracy.

It is comparatively easy to find some position, such as gate tender or crossing watchman, for the old employee in the

transportation department, or the employee that has been crippled through some unfortunate accident, but in the mechanical department it is quite an undertaking to place the old employee so that he will be contented and show some returns. An old employee that has shown much skill and good judgment throughout his long term of service may be in good condition to inspect or instruct along the lines of his trade, although he is not strong enough to handle the heavy work that is now required on our large locomotives. As a suggestion, why not appoint them as inspectors about the shop? They have learned the folly of jumping at conclusions, and by working with the young mechanics will be in a position to offer many good ideas to improve the shop output.

### PRACTICAL SUGGESTIONS

Where is it possible to secure a better safety inspector than to select some old employee that has seen the result of carelessness and haste? Perhaps he will be recognized as an "old granny," but is it not better to have an ounce of prevention than a pound of cure? It is not necessary to accept everything he reports, but if his suggestions are passed on by the regular shop safety committees, it will be found that many of his ideas are good. Much time is lost in the shops because of tools and shop appliances being misplaced and any old mechanic will more than earn his salary by looking after such tools. Shop jacks are seldom oiled, with the result that they very often get out of repair. Pinch bars are usually dull when required for a hurry-up job; both of these items can be looked after by some worn out mechanic that is unable to handle regular shop work, but is still able to get about the shop. After a serious accident has happened because of a sledge handle breaking or the head flying off the handle, it has been found a paying investment to have such tools looked after by an old workman who is familiar with the small defects that often result in bad accidents. In the fall, when it begins to get dark during the regular shop hours and the workmen require torches, it is quite an economical practice to have an old mechanic gather up all the torches about the shop and fit them up ready for immediate use so that it will not be necessary for a high-priced mechanic to waste time in doing so.

In a small shop where a crippled tinsmith was employed it was found that there was not enough tin work to keep him busy. As he was both a good workman and anxious to keep busy, he suggested that all the old lanterns on the division

be sent in so that he could overhaul them. After it was tried out for a short time, it was found to be such a good idea that all the lanterns on the entire railroad were shipped to that one point for repairs, and additional men were employed to keep the repairs up.

On another road where it had been the practice for some time to sell wagon loads of scrap wood removed from the freight cars at fifty cents a load, a worn out or "scrap" carpenter was given charge of the scrap woodpile. This man was badly crippled with rheumatism and hardly able to write, so it was impossible for him to keep an elaborate set of records, but he had proved his honesty in his long term of service and he was therefore assigned to watch the woodpile. He soon proved that while he could not do manual labor, he still had his wits about him and that with a very little sorting there was much second wood that could be used over again to make box car doors and other parts of wooden cars. He also put the scrap pile on a commercial basis so that it paid better than when there was no one directly interested in it.

These two men showed to their employers that although they were classed as old worn out material, commonly called "scrap," they were still able to be "reclaimed" and be put to some useful purpose, even if not at the same tasks they had worked on all their lives. If these men were successful, is it not possible that there are many more in the same position on other roads?

#### IN THE CAR REPAIR YARD

In a large car repair yard an old employee was placed on the retired list and was soon forgotten. He had been used to hard work all his life and the awful monotony of hanging around soon made him sick. He was big enough to realize that if he gave up and went home, he would never get back again so he appointed himself the task of picking up all the discarded nuts and washers around the car repair yard. He soon had such a busy job that he forgot his troubles and at the end of six months it was found that he had actually saved more material than his wages came to. He not only saved material but he had it so placed that the workmen did not lose time getting it, which was another big item of saving.

Another way to take care of the worn out employees is to appoint them fire inspectors or building watchmen, for as a rule the old men are punctual and trustworthy and make the best kind of inspectors, for they are on the job all the time. As a man grows older in the service, he thinks less of his own personal pleasures and more of his employer's interests. This is proven during vacation time for we find that where some young man will plan an elaborate vacation, the old "timer" will not take any time off. This thought is not presented to imply that vacations are not necessary, for they are a positive requirement, but often a foreman who has been on the job for several years will never take the regular and necessary rest which the younger man calls his vacation.

#### SEVENTY YEARS YOUNG

No matter how small a shop is, there is some place where the old, faithful employee can be taken care of both to his and the company's advantage. All old men are not scrap, which is to be thrown away as useless. We are all familiar with a certain important railroad president who was "70 years young" at his seventieth birthday. This wonderful man at that age ranked as one of the most active heads of any railroad in the United States. Just imagine the loss to his railroad if he had been relegated to the human scrap pile at the time when his long years of training and experience fitted him to give the very best of service.

One of the most important things in the life of a railroad man is to be able to exercise discretion; very often we find a young man is not given a responsible position because he has not yet reached the age of proper discretion, or had the

necessary training to learn its very important bearing on successful railroading; yet right on top of this we find that some other employee is considered too old and is appointed a candidate for the scrap pile.

#### STOPPING LEAKS

In a large plant having an extensive heating system, one of the plumbers was too old to do the regular work so the foreman gave him the job of looking after all the small steam leaks about the plant. He was told that "a stitch in time saved nine" and to stop a small steam leak would very often prevent a larger one. After the old man had been on the job for a short time, the heavy steam heat repair jobs began to be less frequent. Still another old employee was given the task of looking after all the water leaks. He had to inspect all pipes, faucets and other places where water was used; he soon showed that his appointment was profitable to his company.

In another large industrial plant, the original founder has been displaced by his two sons, but he refuses to be turned over to the scrap pile and very frequently goes into the shop and works with the mechanics. By doing this, he feels that he is still in trim to do a day's work and the men about the plant, realizing and appreciating his wonderful vitality, are all the more loyal to the company. No job in the shop is too dirty or too hard for the old man to tackle and his example is followed by every employee.

It is not often that we find an employee who is looking forward to that day when he will be told to remain at home with nothing to do but draw his pension. It is nice to think of the pleasure of having nothing to do but the old employee will find himself in the same position as the old discarded fire horse that was used on a milk route. While standing one day near a fire station, an alarm came in and the old horse responded to his early training by making a record run. It is the old employees who will tell you that the best music they know of is to hear the old shop whistle call the men to work and to realize that they are able to respond.

#### THE HARE AND THE TURTLE

Local conditions vary so much that it is impossible to work out any set rule to govern the proper placing of the old employee, but if a careful study is made of the shop conditions, some place will be found where the old men can be used to good advantage. The excuse of the old man being too slow for the present day requirements can be answered by quoting the result of the race between the hare and the turtle, for while it must be admitted that the old man is slower, the fact remains that he will get results. We will always have the old fellows around the shop and it is up to the successful manager to provide some position not only to keep them busy, but to keep them satisfied so that they will not have the impression that they are discarded pieces of junk and only fit for the scrap pile. If the success of reclaiming scrap material is established then the success of reclaiming the old employee is assured and the company will receive as much benefit from one as the other.

There is no limit to what can be done for the old employee for which the company will receive some returns. In a certain large shop, an old employee complained of the bad lighting system and offered the excuse that he was not as young as he used to be and that his eyesight was failing. Investigation developed the fact that the lighting system was very bad not only for the old man but for the young mechanics; by making certain changes the efficiency of all the workmen was increased to a marked degree. In another shop, an old employee reported that he was unable to handle the heavy work he had been doing for several years as there were no cranes or other conveniences to lift the heavy castings. An investigation proved that the shop was so far behind the times on shop conveniences that it was in the antiquated

class and the old employee was assigned to select and locate any apparatus that would facilitate the work. He soon showed that where formerly two and three men were required on a job, the same work could be handled more quickly and economically by one man with the use of mechanical apparatus for doing the "strong back" work than when it was handled by several workmen. The number of accidents was reduced and the shop output increased, all because an old worn out employee was "reclaimed."

It is impossible to give all the examples of what has been accomplished by reclaiming the worn out employee, but as every shop has the necessary material to work on, it is suggested that every one get busy and see what can be done at their plants.

Just remember that the proper definition of the word reclaim does not mean to reform or make like new, but should be given the broader sense of "to be used to take the place successfully of something else."

### DIAMETER OF DRIVING AXLE JOURNALS

BY L. R. POMEROY

The usual method of calculating the combined or resultant lever arm for bending and twisting is as follows: Let *A B* equal the crank radius and lever arm for twisting, and *B C* the distance, in cross section, from the center of

The method of reading the diagram is shown by the dotted line given as an example. Starting from boiler pressure, follow downward to the diagonal for Cylinder diameter (at which point the piston thrust can be directly read on the right hand margin). From this point read horizontally to the left, to the diagonal for the resultant lever arm *L<sub>r</sub>*, and thence upward to the top, where the diameter is read. The resultant *L<sub>r</sub>* is found by means of the small diagram.

The diagram in Fig. 2 is arranged to find the fiber stress from any given axle diameter. The method is practically the same as that employed for Fig. 1. For example, beginning at boiler pressure, follow down to the diagonal for cylinder diameter, thence to the left to the diagonal for axle diameter, thence upwards or downwards, as the case may be, to the diagonal for *L<sub>r</sub>*, and from *L<sub>r</sub>* to the left to the margin, where the fiber stress is read; *L<sub>r</sub>* is found as in Fig. 1 from the small sketch shown on the diagram.\*

The diagram shown in Fig. 3 is to determine the diameters of crosshead and crankpins (other than the main crankpin), on the basis of allowable piston thrust against the projected area (diameter multiplied by the length) of the pins. This diagram is read in the manner prescribed for those in Figs. 1 and 2; that is, from boiler pressure down to cylinder diameters, thence to the left to either one of the two diagonals for crosshead or crank pins and

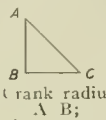

Name of road	Type	Cylinder diameter and stroke	Boiler press., lb. per sq. in.	Distance from center line through cylinder to center line through frame, A B; lever arm for torsion. Inches	Distance from center line through cylinder to center line through frame, B C; lever arm for bending. Inches	Combined or resultant lever arm A C $\sqrt{AB^2+BC^2}$ Inches	Diameter of main axle by formula; f. s., 21,000 lb. basis of cyl. diam. + 1/2 in. for wear. Inches	Actual diameter in use on the locomotive. Inches
Ill. Cen.	2-8-2	27 x 30	175	15	23.5	27.8	10.95	11.00
C. & O.	2-8-2	29 x 28	170	14	24.5	28.2	11.50	11.50
C. & O.	4-8-2	29 x 28	180	14	24.5	28.2	11.70	11.50
C. & O.	4-6-2	27 x 28	185	14	25.0	28.7	11.40	11.50
Mo. Pac.	2-8-2	27 x 30	170	15	23.5	27.8	11.00	11.00
Erie	2-8-2	28 x 32	170	16	24.5	29.2	11.60	11.00
Erie	2-10-2	31 x 32	200	16	26.5	30.9	13.15	13.00
C. & N. W.	2-8-0	25 x 32	170	16	23.5	28.4	10.58	10.50
C. & N. W.	4-6-2	23 x 28	190	14	23.0	26.9	10.20	10.50
A., T. & S. F.	4-6-2	26 x 26	200	13	24.5	27.7	11.26	11.00
C. P. R.	2-8-2	23 1/2 x 32	180	16	24.0	28.8	10.30	10.00
C. P. R.	4-8-2	23 1/2 x 32	200	16	22.0	27.2	10.48	11.00
P. R. R.	4-4-2	23 x 26	205	13	20.75	24.5	10.10	9.50
P. R. R.	2-8-2	27 x 30	205	15	24.0	28.3	11.60	11.00
L. V.	4-6-2	25 x 28	215	14	23.5	27.8	11.20	10.00
K., F. & P.	4-6-2	26 x 28	200	14	24.5	28.2	11.44	11.50
C., B. & Q.	2-10-2	30 x 32	175	16	24.0	28.8	12.08	12.00
B. & O.	2-8-2	24 x 32	200	16	24.5	29.3	10.90	11.00
C., M. & St. P.	2-8-0	23 x 30	200	15	22.5	27.0	10.40	10.50
C., M. & St. P.	4-6-2	23 x 28	200	14	23.0	26.9	10.30	10.00
N. Y. C.	4-6-2	23 1/2 x 26	200	13	23.0	26.4	10.60	10.50
N. Y. C.	4-6-2	24 x 26	200	13	23.0	26.4	10.60	10.50
N. Y. C.	4-6-2	26 x 26	180	13	23.0	26.4	10.70	10.50
N. Y. C.	4-6-2	26 x 26	180	16	23.0	28.0	10.70	10.50
N. Y. C.	2-8-2	25 x 32	180	16	23.0	28.0	10.70	10.50
A. L. Co., 50,000.	4-6-2	27 x 28	185	14	23.0	26.9	11.20	11.00
B. & O.	2-10-2	30 x 32	200	16	26.0	30.3	12.70	13.00
D., L. & W.	4-6-2	25 x 28	200	14	24.0	27.7	11.05	11.00
G. N.	4-8-2	28 x 32	180	16	23.0	28.0	11.48	11.00
P. & R.	2-8-2	24 x 32	225	16	24.0	28.8	11.10	11.00
L. S.	2-8-2	27 x 30	190	15	24.5	28.7	11.60	11.50
C., R. I. & P.	2-8-2	28 x 30	180	15	24.5	28.7	10.32	11.50
W. & L. E.	2-8-0	26 x 30	185	15	24.0	28.2	11.14	11.00

\* Heat treated axle. † Vanadium steel axle.

the cylinder to the center of the frame. Combining, the resultant or equivalent lever arm for bending will be:

$$L_r = \frac{BC + \sqrt{(BC)^2 + (AB)^2}}{2}$$

The writer has adopted a simplification of this, namely:

$$L_r = \sqrt{(BC)^2 + (AB)^2}$$

This method provides a resultant lever arm about 8 per cent greater than that obtained by the former method, which at least is an error toward greater strength rather than a reduction. To demonstrate just how axles designed by this latter method compare with existing practice, the accompanying table is submitted:

With a view to still further simplifying the method of finding the proper diameter the diagram in Fig. 1 is offered.

upward to the top scales for projected area. The allowable piston thrust for crosshead pins is given as 4,600 and 4,800 lbs., and for crank pins 1,600 and 1,700 lbs.

There are several methods of calculating the diameter of main axles which are more complicated and involved than the method described. In each case a lower fiber stress is used in connection with the static load on the axle and the support of adjacent side rods, in connection with

\*The diagrams are based on the following formulas: For Fig. 1—

$$\text{Diameter of axle, } d = \sqrt{\frac{(\text{dia. Cyl.} + \frac{1}{2} \text{ in.})^2 \times .7854 \times \text{Boiler Pressure} \times L_r}{21,000 \times 0.0982}}$$

For Fig. 2—

$$\text{Fiber stress} = \frac{(\text{dia. Cyl.} + \frac{1}{2} \text{ in.})^2 \times .7854 \times \text{Boiler Pressure} \times L_r}{d^3 \times 0.0982}$$

assuming a fiber stress of 21,000 lb. and ignoring the dead load or support of adjacent side rods.

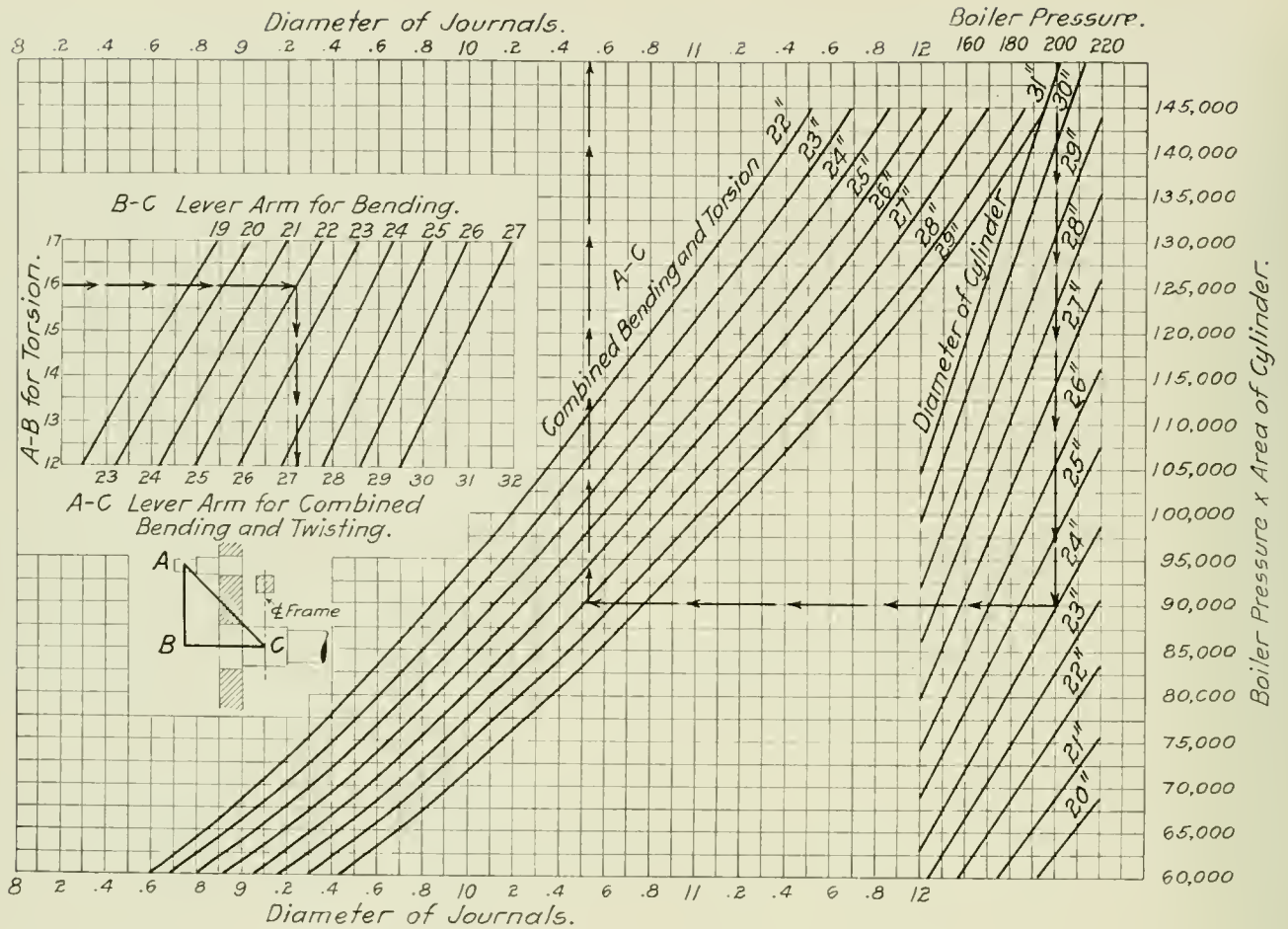

Fig. 1—Diagram for Determining the Diameter of Driving Axle Journals

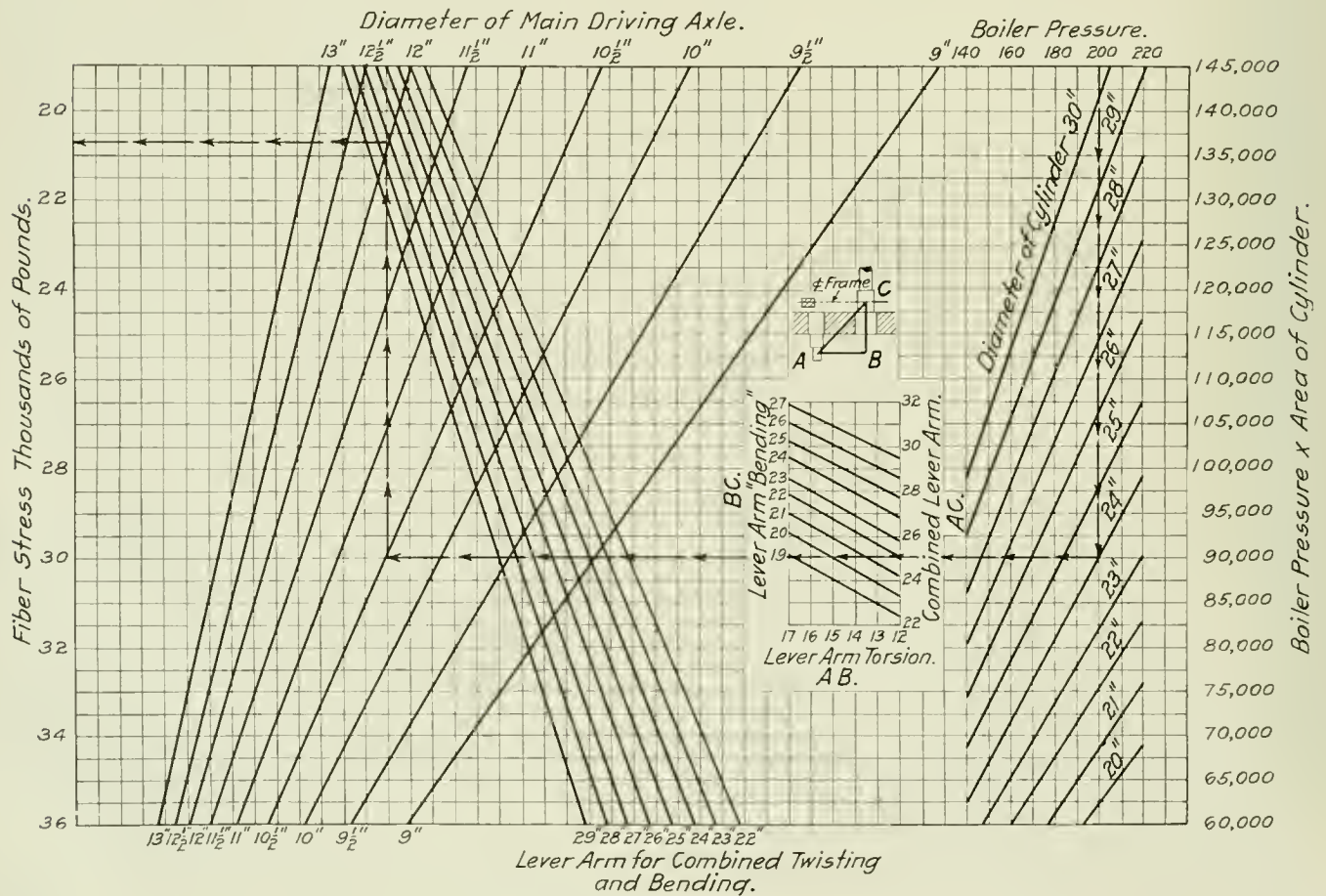

Fig. 2—Diagram for Determining the Fiber Stress for Any Given Axle Diameter

combining the torsion and binding. As all of these methods provide in the end for practically the same size of axle as that obtained by the writer's method, no hesitation is felt in offering the shorter way, especially as the table, showing current practice checks so closely. The methods referred to are as follows:

I. Method employed by G. L. Fowler and C. J. Mellin in Machinery's Hand Book, No. 29.

$$\text{Fiber stress} = \sqrt{\left(\frac{Pl}{2}\right)^2 + (Wb)^2 + \left(\frac{0.3 \times W \times D}{s} \times r\right)^2} = (\text{dia. axle})^3 \times 0.0982$$

Where P = (dia. Cyl.)<sup>2</sup> × 0.7854 × Boiler Pressure,  
 l = Distance from center line of main rod to center line through frame,  
 b = Distance from center line of rail head to center line through frame,  
 W = Weight on axle = Weight on pair of main wheels and axle, less weight of wheels and axles,  
 D = Diameter of drivers,  
 s = Stroke in inches,  
 r = Radius of crank.

$\frac{Pl}{2} + (W \times b)^2$  = Bending moment due to piston thrust plus dead weight.

$\left(\frac{0.3 \times W \times D}{s} \times r\right)^2$  = Bending moment due to torsion.

It is stated that the torsional stress is taken as the weight necessary to slip the drivers, with the claim that anything

the full bending force of the piston; therefore half the piston thrust is used. Also, one-half the piston thrust is taken for both bending and torsion as noted in the formulas.

For example, let us consider a 2-8-0 type locomotive with P = 70,000 lb., l = 22 in., W = 40,000 lb. (less wheels and axles) = 32,000 lbs., b = 10 in., crank radius = 13 in., stroke = 26 in., D = 57 in.

$$\text{Fiber stress} = \sqrt{\left(\frac{70,000 \times 22}{2}\right)^2 + (32,000 \times 10)^2 + \left(\frac{0.3 \times 40,000 \times 57}{26} \times 13\right)^2}$$

$$= 819,550 = \text{moment in inch-pounds.}$$

Then the f, s, solving  $\frac{819,550}{d^3 \times 0.0982} = \frac{819,550}{50.28} = 16,300 \text{ lb.}$

Or with a fiber stress of 16,000 lb. the limit used in the text, the diameter equals

$$\sqrt[3]{\frac{819,550}{16,000 \times 0.0982}} = 8.035 \text{ in.}$$

To this is added an allowance for wear for cylinder and axle and the axle diameter is then 9 in. at the journal.

II. G. R. Henderson's method:

This is on the basis of combined bending due to piston thrust and dead weight. Torsion is not included as it is

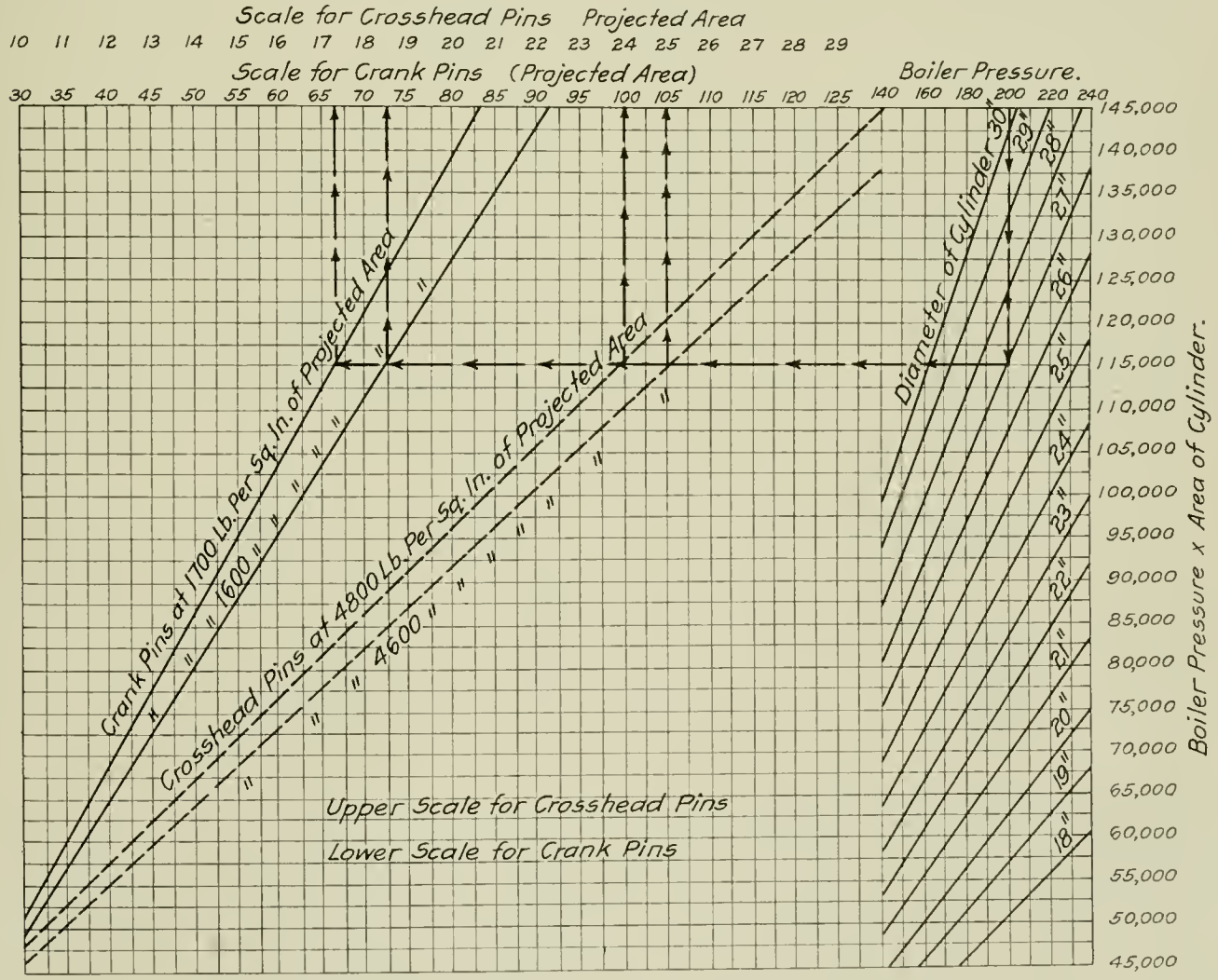

Fig. 3—Diagram to Determine the Diameters of Crosshead Pins and Crank Pins

above this is transferred through the side rods to the adjacent drivers, as one crank is in a favorable position to slip the wheels when the other is on the dead center, thus taking up all the slack in the rods and relieving the axle from

assumed that the piston is at the end of the stroke and the crank is on the center, under which conditions no torsion is present. Torsion is considered at a maximum when the pin is at the top or bottom quarters.

Using the same symbols, quantities, and dimensions as above the fiber stress for a 9-in. axle becomes

$$\frac{\sqrt{(P)^2 + (\frac{1}{2} W \times b)}}{71.6} = \frac{\sqrt{(70,000 \times 22)^2 + 200,000^2}}{71.6} = 21,680 \text{ lb.}$$

At the top quarter we still have the vertical bending moment,  $\frac{1}{2} Wx$ , as at the end of the stroke, but the horizontal force is dependent on the slipping of the wheels. The force P., causes a horizontal bending moment  $Px$ , but the resistance to slipping of the rear wheel also causes a horizontal bending moment in the same direction, whose value is  $\frac{Wxb}{2 \times 3.5}$  and the horizontal bending moment becomes;—

$$W \times \frac{(D \times l) + (b \times r)}{7 \times r}$$

The twisting or torsion moment equals

$$\frac{W \times D}{14}$$

Combining the bending moments we have

$$\sqrt{(\frac{1}{2} W \times b)^2 + \left[ W \times \frac{(D \times l) + (b \times r)}{7 \times r} \right]^2} = \sqrt{\left( \frac{40,000 \times 10}{2} \right)^2 + \left( \frac{40,000 \times 57 \times 22 + 10 \times 13}{7 \times 13} \right)^2} = \sqrt{200,000^2 + 608,000^2} = 639,700$$

$\frac{W \times D}{14} = \frac{40,000 \times 57}{14} = 163,000 = M_t$  or twisting moment.

According to Rankin the equivalent bending moment when  $M_b$  is greater than  $M_t$  =

$$M_{br} = \frac{1}{2} M_b + \sqrt{M_b^2 + M_t^2} \text{ or } \frac{639,700}{2} + \sqrt{639,700^2 + 163,000^2}$$

979,050  $M_{br}$ ; or the combined bending and twisting moment in inch-pounds. The fiber stress becomes

$$\frac{979,050}{d^3 \times 0.0982} = 13,700 \text{ lb.; or for a } 9\frac{1}{2}\text{-in. axle } \frac{979,050}{84.19} = 11,500 \text{ lb.}$$

III. F. J. Cole's method given in the *American Engi-*

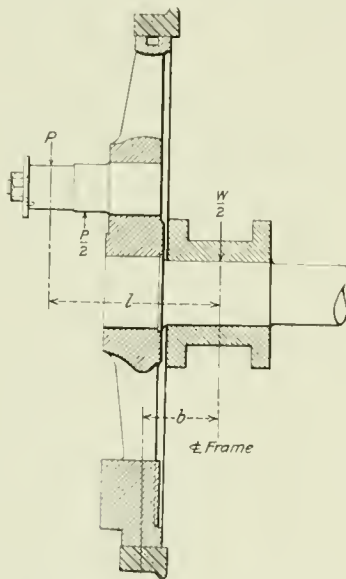

Diagram for Use with Method 1

ner, April 1898, page 124, using the same symbols and figures as for previous illustrations:

1. Fiber stress from bending moment due to piston thrust,—

$$f. s. = \frac{P \times l}{2 \times R} = \frac{70,000 \times 22}{2 \times 71.6} = 10,800 \text{ lb.}$$

$(71.6 = R \text{ for } 9\text{-in. axle})$

2. Fiber stress from bending moment due to dead load,—

$$f. s. = \frac{W \times b}{2 \times R} = \frac{32,000 \times 10}{2 \times 71.6} = 2,240 \text{ lb.}$$

Combining to arrive at the resultant f. s.,—

$$\sqrt{10,800^2 + 2,240^2} = 11,020 \text{ lb.}$$

For the torsional stress the force of the piston is divided equally between the driving axles. In the illustration used there are four driving axles. We then have

$$\frac{\frac{1}{2} P \times r}{4 \times R} = \frac{70,000 \times 13}{8 \times 71.6} = 1,580 \text{ lb.}$$

Mr. Cole assumes that one-half of this quantity is the maximum torsional stress likely to occur at any one time. Then we have

$$1,580 \div 2 = 790 \text{ lb.}$$

The stress due to centrifugal force =

$$\frac{W \times v^2}{8 \times \text{radius of curve}} = \frac{40,000 \times 5,373}{32.2 \times 955} = 7,000 \text{ lb.}$$

The lever arm =  $\frac{1}{2}$  the diameter of the drivers =  $28\frac{1}{2}$  in. and the fiber stress due to centrifugal force =

$$\frac{7,000 \times 28.5}{71.6} = 2,803 \text{ lb.}$$

This is based on a 6 deg. curve, = 955 ft. radius, a speed of 50 m. p. h., of 73 ft. per sec. ( $73^2 = 5373$ ).

The flange pressure was assumed as not to exceed one-half of the torsional force, the remainder being assumed to be absorbed by the outer rail, or equal to 790 lbs. The equivalent bending moment as above equals 11,020 lb. Combining this with the torsional stress the final resultant

$$f. s. = \frac{11,020}{2} + \sqrt{\left( \frac{11,020}{4} \right)^2 + 790^2} = 11,407 \text{ lb.}$$

or say a 9-in. axle.

Mr. Cole places the f. s. limit for fiber stress as follows:

2-8-0 type	8,500 lb.
4-6-0 and 2-6-0 types	9,500 lb.
4-4-0 type	13,000 lb.

If a  $9\frac{1}{2}$ -in. axle is chosen the f. s. would be

$$\frac{70,000 \times 22}{2 \times 84.20} = 9,200 \text{ lb.}$$

$$M_{br} \text{ due to piston thrust} = \frac{W \times b}{2 \times 84.20} = \frac{32,000 \times 10}{2 \times 84.20} = 1,900 \text{ lb.}$$

$$M_{br} \text{ due to dead load, combining} = \sqrt{9,200^2 + 1,900^2} = 9,397 \text{ lb.}$$

$$\text{Torsion} = \frac{\frac{1}{2} P \times l}{4 \times R} = \frac{70,000 \times 13}{8 \times 84.20} = 1,350 \text{ lb.}$$

Assuming one-half this amount, as before = 675 lb.,

$$f. s. = \frac{9,397}{2} + \sqrt{\left( \frac{9,397}{4} \right)^2 + 675^2} = 9,441 \text{ lb. f. s.}$$

which, according to Mr. Cole's limit stress would call for a  $9\frac{1}{2}$ -in. axle.

Recapitulation:—

I. Method of G. L. Fowler and C. J. Mellin calls for a 9-in. axle.

II. Method of G. R. Henderson calls for a 9-in. axle.

III. Method of F. J. Cole calls for a  $9\frac{1}{2}$ -in. axle.

The diameter found by the writer's method, using the same figures as in the foregoing cases and based on 21,000 lbs. fiber stress is:

Equivalent or combined lever arm equals

$$\sqrt{13^2 + 22^2} = 25.5 \quad P = 70,000;$$

Then the diameter of the axle =

$$\sqrt[3]{\frac{70,000 \times 25.5}{21,000 \times 0.0982}} = 9.47 \text{ in.}$$

CORROSIVE EFFECT OF ACETYLENE.—With the increasing use of acetylene gas the risks of its corrosive effect on pipes and metal containers should be better known. Tests have shown that most acetylene, as generated, attacked zinc, lead, brass and nickel to a slight extent; iron was affected six to seven times as much; but copper suffered more than any other metal tested. Copper was quickly changed into a soft, porous black mass. Tin, aluminum, bronze, german silver and solder were practically unaffected. Thus it would appear that copper and brass or other copper alloys should not be used as piping for acetylene-gas supplies, and that iron should be well tinned rather than galvanized or nickel plated.—*American Machinist*.



# THE LOCOMOTIVE INSPECTION RULES\*

Explanations Which Should Help to Prevent Misunderstandings of New Federal Government Code

BY FRANK McMANAMY

Chief Inspector of Locomotive Boilers, Interstate Commerce Commission, Washington, D. C.

The locomotive inspection law is comparatively new, and is so comprehensive that explanations will no doubt be of substantial value in assisting carriers to meet the requirements. The locomotive inspection law and rules in no way affect or change any of the requirements of the locomotive boiler inspection law or rules. It is true that the form of reports for monthly and annual inspections were changed somewhat, a combination form covering the entire locomotive, including the boiler, being adopted, but this was done to avoid the necessity of requiring additional sworn reports, and not for the purpose of modifying in any way the boiler inspection requirements.

## BOILER LAGGING REQUIREMENT

While we cannot assume the duty of advising carriers in every case of the expiration of periods allowed by the rules for making various tests and inspections, it is not out of place to direct attention to the fact that the five-year period for the removal of lagging from all boilers which were in service on June 30, 1911, expires on June 30, 1916, and that before that time they must have had at least one removal of lagging and have had the entire exterior of the boiler thoroughly inspected, as provided by Rule 16. On account of having postponed as long as possible any effort to meet this requirement, some carriers are now adopting the practice of simply removing and replacing the jacket and lagging when the locomotive is in for monthly inspection, and so reporting on Form No. 1. This does not meet the requirements, and Form No. 1 cannot properly be used for making such reports. The purpose of requiring a complete removal of lagging is to permit a thorough inspection of the entire exterior of the boiler, which can only be made while the boiler is under pressure; therefore, hydrostatic test must be applied while the lagging is off, and a report made on Form No. 3.

## THE LOCOMOTIVE INSPECTION RULES

In the preparation of the rules which were approved by the Commission in their order of October 11, 1915, effective January 1, 1916, it was considered advisable to follow as closely as practicable the general plan of the locomotive boiler inspection rules, particularly with respect to making inspections and filing reports by the carriers. The purpose of this was to avoid, as far as consistent with a satisfactory compliance with the requirements, inconvenience and expense to carriers in the matter of making reports.

In order to avoid a duplication of reports, combination reports (Forms Nos. 1 and 3) were prepared, which cover the work required by the locomotive boiler inspection law and rules, and also by the amendment to the law and the rules issued in accordance therewith, and take the place of reports (Forms Nos. 1 and 3) previously required and, in general, these reports should be handled the same as the former ones were.

I shall not attempt to explain or define each rule. I will try, however, to make clear those that are somewhat general in their terms, and also any with respect to which numerous questions have been asked.

It will be noted that Rule 1, of the locomotive inspection

rules is identical in its requirements with Rule 1 of the boiler inspection rules, and makes the railroad responsible for the general design, construction and maintenance of locomotives and tenders. Rule 2 is identical with Rule 7 of the boiler inspection rules, and makes the officer in charge at each point where inspections are made responsible for the inspection and repair of all locomotives under his jurisdiction. Rule 3 is exactly the same as boiler inspection Rule 8, defining the meaning of the term "Inspector." And they are intended to accomplish the same general results.

## RULE 4—DAILY INSPECTIONS

Rule 4 of the locomotive inspection rules reads as follows:

Each locomotive and tender shall be inspected after each trip, or day's work, and the defects found reported on an approved form to the proper representative of the company. This form shall show the name of the railroad, the initials and number of the locomotive, the place, date, and time of the inspection, the defects found, and the signature of the employee making the inspection. The report shall be approved by the foreman, with proper written explanation made thereon for defects reported which were not repaired before the locomotive is returned to service. The report shall then be filed in the office of the railroad company at the place where the inspection is made.

The general purpose of this rule is to require the present practice of inspecting locomotives daily to be continued, and to avoid, if possible, the necessity of requiring additional sworn reports of inspection. It is the practice of some carriers immediately to conform to a Government requirement that is less rigid than their present system of inspection, apparently overlooking the fact that Government requirements are not shop standards, or intended to represent the general condition of equipment, but are minimum requirements, or limits which mark the point at which the Government will take action to bring about necessary improvement in the condition of equipment. In other words, they represent the extreme condition in which the locomotive will be permitted to continue in service.

This being true, the effect of fixing by rule a monthly inspection only, would be, in many instances, to have the carriers accept that as the Government standard and neglect inspections between those periods. The law was not intended to relieve carriers from inspections which have by years of experience been found necessary, but to insure the performance of these inspections and such others as may be considered essential to proper maintenance of locomotives. Therefore, Rule 4, providing for the usual daily inspection, in addition to the monthly inspection and report, became necessary.

## FIXING RESPONSIBILITY

Form 2, which is required by Rule 4, was intended to accomplish two definite purposes: First, to insure an inspection of each locomotive at certain prescribed periods. Second, to require the foreman or officer in charge to know the condition of the locomotive, and to say why defects reported were not repaired before the locomotive is returned to service. One of the reasons for this is that in many cases it is practically an impossibility when an accident resulting from defective equipment occurs, to fix the responsibility for the defects in question. The officers in charge of the work will often insist that the defect was not properly reported or not reported at all; therefore, that they should not be held responsible for failure to make repairs. The person whose

\* From a paper read at the Western Railway Club, Chicago, March 22, 1916.

duty it was to report such defects insists with equal vigor that the defect was properly reported, perhaps had been reported numerous times, but had not been repaired. Failure to find the reports of a defect does not always indicate that such reports were not made, because frequently carbon or other copies of such reports are obtainable when the original reports cannot be found.

Rule 4, which requires an inspection after each trip, or day's work, and a report showing the defects found, with the signature of the employee making the inspection, and requiring that the report shall be approved by the foreman, with proper written explanation made thereon for defects reported which were not repaired before the locomotive is returned to service, will assist in definitely fixing the responsibility for operating defective locomotives. It will also require the foreman to exercise more careful supervision over the work, so that he may properly sign the report. These inspection reports must be kept on file in the office of the railroad where they can be checked.

Some railroads are starting out with the evident intention of defeating the purpose of this rule. One of the most common methods is to have two reports, one showing everything in good condition, properly approved by the foreman, which is kept on file; another, which may be the usual work book, or a different report, showing the actual defects and the repairs made.

Railroading has, in a spirit of sarcasm perhaps, been described by a railroad man as "the art of placing the responsibility on the other fellow." I do not agree with this definition, or that it particularly applies to railroad men, because I know that men in other lines of work are as proficient in evading responsibility for improper conditions as some railroad men; but we must admit that it pretty accurately describes practices that are too frequently met with.

One illustration of this is the difficulty we are experiencing in getting Form 2 approved by the foreman, "with proper written explanation made thereon for defects reported which were not repaired before the locomotive is returned to service," as required by the rule. We expected some difficulty in getting the inspections properly made, even though the rule differs but little, if any, from rules which were supposed to be in general use, but we did not expect that it would be more difficult to get the foreman to perform his part of the work than it would be to get a proper inspection made. We were still further surprised to find that the objections of the foremen were not to the approval of the report, as that is a comparatively small matter, but the requirement that "proper explanation must be made thereon for defects reported which were not repaired" appears in many cases to be out of tram with their ideas of the duties of a foreman, and many of them resent being required to say why defects reported were not repaired.

#### LACK OF SUPERVISION

If I were to be asked what in my opinion is the principal cause of locomotives being operated with defects which are violations of the rules, I would without hesitation say that the one important cause is lack of proper supervision. The average workman in any line of work will follow the standard set for him by, and which is acceptable to, the person in charge of the work; or, in other words, they will give you just what you will take. It avails nothing to fix a high standard by rule, and then day after day, on job after job, accept work that is way below the standard thus set. This willingness to accept work that is below the standard, or failure to observe that it is below the standard, has a demoralizing effect on the force and is the principal cause for poor work being turned out.

In one instance a general officer of a railroad asked if there was not some way of being relieved from making out Form 2, stating that the mechanical officers had informed

him that they did not understand how they could hold their positions under the new rule which made it necessary to report actual conditions and show a record of the work not performed, with the reason. Upon being asked if the new rules would cause defects on their locomotives, he admitted that they would not. Further questioning brought out the admission that the only effect of this rule would be to require the officer in charge to assume the responsibility for sending locomotives out in a defective condition, and without repairs being made to defects which were reported.

The mechanical officers on the road in question appeared to be perfectly satisfied to have the locomotives continue in service in a defective condition so long as they did not have to sign a report assuming the responsibility by showing that the defective condition had been reported and not repaired, and that the return of the locomotive to service without proper repairs had been approved. When that happened they immediately advised the general officers that under the new rules they did not see how they could hold their positions.

Some of the principal requirements in Rule 4 about which there appears to be some misunderstandings are covered in the following explanatory circular, which was recently issued:

#### CIRCULAR No. 123

In reply to numerous inquiries relative to the inspections after each trip or day's work, as required by Rule 4 in the Commission's order of October 11, 1915, and to provide for a uniform compliance with its requirements, the following explanations are given:

In road service, the word "trip" as used in this rule ordinarily means one way over a division or district. On branch or turn-around runs where one round trip is made in a day, "trip" will be held to mean "round trip."

In suburban, transfer, or short branch line service where more than one round trip is made each day, also in yard service, "day's work" (instead of "trip") will apply.

For locomotives which make one or more round trips per day, with one end of the run a shop point, inspections made daily at such points will be accepted as meeting the requirements of the rule, even though the day's work is not completed there.

In work-train or other service in which locomotives are tied up at outlying points where repairs cannot be made, inspection reports may be sent to the terminal at which the locomotive is cared for.

For double-crewed locomotives in yard service, where crews change in the yard, one inspection and report each 24-hour period will be required. This may be made when the locomotive is taken in for fuel, water or fire-cleaning; where such locomotives do not go to the shop for this, an inspection period must be provided, and the inspection as provided by the rule made once each 24 hours.

The above explanation are not intended to reduce the number of inspections required by the rule, which are minimum requirements.

In this connection it is well to say at this time that the explanation of Rule 4 shown on page 41 of the explanations of rules issued by the Special Committee on Relations of Railway Operation to Legislation is one with which we cannot agree. The explanation reads as follows:

"Any employee the railroads designate can sign the report instead of the foreman."

This was issued without having been submitted to any representative of the Government, and cannot be accepted, because it is contrary to the very purpose of the rule, inasmuch as under it a call-boy, roundhouse foreman's clerk, or any other employee could approve reports for repairs of which he knew absolutely nothing.

#### WHO MUST SIGN REPORTS

We have stated that at large terminals where the roundhouse foreman or general foreman is unable to approve the reports on account of lack of personal knowledge, the approval of the gang foreman or the mechanic in direct charge of the work would be accepted, because of his having personal knowledge that the work had been properly performed; but we will not accept the report approved by some employee who does not have such knowledge.

The requirements of Rule 4 are identical with the system which has been said to have long been in force on many or practically all important railroads in the country. The instructions shown on the form of report are, in effect, the same as those contained on similar reports which have been

in general use. The only difference is that now there is a Federal requirement that these inspections be performed and the defects reported, and that the foreman shall say why repairs were not made, while prior to January 1, 1916, it was a requirement of the carriers only, and, as was stated by one general manager, "There is a great difference between a Federal rule, which must be observed, and the same rule adopted by a railroad company, which may be varied from at pleasure." Rule 4 and Form 2 simply continue in force what has been said to have long been the general practice with respect to locomotive inspection.

#### ASH PAN REQUIREMENTS

Rule 5 cannot, and was not intended to, modify or change the act of May 30, 1908, known as the ash pan act, requiring every locomotive to be equipped with an ash pan which can be dumped and emptied or cleaned without the necessity of an employee going under such locomotive. It was intended to, and does, provide that such ash pans shall be securely and properly attached and supported, and that the operating mechanism shall be properly arranged and maintained in a safe and suitable condition for service. Our inspections have disclosed numerous cases where ash pans are not maintained in accordance with the requirements of the law, the best evidence of which is the fact that it is an easy matter to find some man under a locomotive hoeing out the pan, because the devices for cleaning it are inoperative or inefficient.

#### ORIFICE TESTS OF AIR COMPRESSOR

Rules 6 to 15 cover the inspection and condition of brake and signal equipment, and provide, first, for an inspection before each trip, to see that the brakes are in a safe and suitable condition for service; second, for a service test to show the general condition of the compressors.

One of the points on which the most numerous requests for information have been received, is the method of making an orifice test of an air compressor, and where the fitting containing the orifice disk should be attached. That is a matter on which we are not going to make a positive rule, because the orifice must be attached at some point where it will receive the supply of air from the compressor. The usual method is to attach it to the main reservoir, which is entirely satisfactory to us. If, for convenience, it is desired to attach it to the brake pipe at the rear of the tender, we will not object, because that is a more severe test than the rules require, inasmuch as the compressor must also supply any brake pipe leakage that may exist.

#### "CLEANING WITH STENCIL AND PAINT BRUSH"

Tests of distributing or control valves, reducing valves, triple valves, straight-air double-check valves, dirt collectors, and brake cylinders are also required at regular intervals, and a choice of three methods of recording the date of these tests is given. That is, it may be stenciled on the parts, stamped on metal tags attached thereto, or displayed on a card under glass in the cab of the locomotive.

The rules so far have not required sworn reports of these tests to be filed, but the practice which we find is being followed on some railroads indicates that such a rule may become necessary, as we have found that the practice which has long been too general on repair tracks of "cleaning" triple valves and brake cylinders on cars by means of a stencil and paint brush, is being adopted for locomotive practice, and dates of testing and cleaning are being placed in the cab without any work having been performed. In a number of instances the date shown has been one on which the locomotive was not at the terminal at all. This practice, if followed, will surely result in a change of the rule requiring such reports to be sworn to, placing a greater measure of responsibility on the inspector and officer in charge.

#### CLEAR VISION WINDOWS

Rule 16 covers the condition of cabs, warning signals and sanders, and attempts to provide for a reasonable view of the track and signals for the enginemen. One of the requirements which seems to be not generally understood is that relating to clear vision windows. It may be, perhaps, that the description of this window is not as complete as it might be. The term, however, indicates what is desired, and should in itself prevent the application of some of the windows which were designed to be used under this requirement. I refer particularly to the type of window, supposed to meet this requirement, which has a wooden frame from 1 in. to 2½ in. in width across the front cab window directly in the line of enginemen's vision. This surely could not under any circumstances be called a "clear vision" window. What is desired is not an obstruction, but something that will give an unobstructed view of the track and signals during stormy weather. On the best types the glass is securely attached to a frame at the top and sides only, leaving no obstruction across the center of the window at the bottom of the opening. Such a window will not obstruct the engineman's vision in any way when closed, and in stormy weather, if opened slightly, it will give the engineman an unobstructed view of track and signals, which cannot be obtained with his head out of the side cab window in a severe snow or rain storm.

#### TIMES FOR TESTS AND INSPECTIONS

Misunderstandings with respect to the periods within which the various tests and inspections required by the locomotive inspection rules must be performed have caused some confusion, and are resulting in some instances in carriers making an extra effort to make tests which might properly, and perhaps more satisfactorily, be made at a regular inspection period, and in other instances failing to make tests which should be made at inspection periods, and which will cause additional expense and delay to equipment when they are required later.

To make this point clear, beginning January 1, 1916, which is the date the locomotive inspection rules became effective, all tests or inspections required by them should be made within the prescribed periods. That is, inspections required monthly should be made within the first month, inspections required quarterly should be made within three months; and inspections required annually should be made within the year. This permits inspections required under the locomotive inspection rules to be made at the time the boiler inspections are made, and avoids the necessity of holding locomotives especially for this inspection.

When the locomotive is held for inspection, all of the work should be done; otherwise, it is sure to cause inconvenience later. To illustrate: Hydrostatic test of main reservoirs is required at least once each year. The intent of this clearly was that this test should be made when the hydrostatic test is applied to the boiler, but we are receiving annual reports from many roads showing hydrostatic test applied to the boiler, but none to the main reservoir. This is not only a failure to comply with the intent of the rule, but is sure to result in an inspector ordering the locomotive held to have this work done, and it may occur at a time which will be very inconvenient.

#### DRAW GEAR INSPECTIONS

There has been some question as to the proper answer to item 6 on Form 1, with reference to the condition of draw gear between locomotive and tender. Rule 22 provides in part that—

The pins and drawbar shall be removed and carefully examined for defects not less frequently than once in three months.

This has been interpreted by some to mean that the condition need be shown but once in three months, but it simply

provides a particular inspection for the pins and drawbar which should be made. The first sentence of the rule requires that—

The draw gear between the locomotive and tender, together with the pins and fastenings, shall be maintained in safe and suitable condition for service. Which means not only the drawbar and pins, but also the safety bars or chains, with their fastenings; therefore, they must be known to be in good condition, and so reported on each monthly report in answer to item 6. When the drawbar and pins are removed to make the special inspection required by the rule, that should also be indicated on the report. The remaining rules follow, with some slight modifications, the standard practice recommended by the Master Mechanics' Association, which should be so well understood that explanations are not necessary.

ACCIDENTS REPORTED

Up to March 1, accidents reported to us under the locomotive inspection rules had killed 7 and injured 113 persons, and we know that, perhaps on account of failure to fully understand the requirements, all were not reported. Among the most serious, as well as the most frequent, class of accidents are draw gear failures, allowing locomotive and tender to separate, 14 accidents of this character, resulting in two killed and 13 injured, having been reported. Twenty-two persons were injured by defective reversing gear. Broken spring hangers have caused two deaths and six injuries. Cylinder-head failures have killed one and injured six.

A general classification of accidents due to failure of parts of the locomotive and tender covered by the amended law has not been made, but is sure to be surprising. It is our purpose to investigate them carefully, and classify them, giving the cause. After a year or two of such work sufficient data will be available to enable not only the representatives of the government, but of the railroads, to systematically and effectively labor to remove the causes, and thereby reduce the number.

CHATTERING WHEEL SLIP IN ELECTRIC LOCOMOTIVES\*

BY G. M. EATON

When the steam pressure in the cylinders of steam motive power is high enough to start slipping of driving wheels, their acceleration is fairly uniform and rapid, the load on the piston being well sustained on account of late cut-off and stored steam in pipes, etc. In contrast to this, with electric motive power, regardless of the method of trans-

mitting the tractive effort from the rotors to the wheels, the acceleration after slipping starts is liable to be erratic, being dependent upon the distribution of rotating masses, and upon the characteristic of the coefficient of friction between wheel and rail.

The only moving parts having relatively high moments of inertia are the driving wheels. In an electric locomotive, the moment of inertia of the rotors, especially when operating through a gear reduction, may be as great as or greater than that of the driving wheels. The combined inertia of connecting rods, cross-heads, piston rods and pistons is practically negligible as far as it affects acceleration of driving wheels after slipping starts. In an electric locomotive, when slipping occurs, the sequence of events is as follows, regardless of the type of drive: Current is applied to the motor and the rotor starts to turn. Clearances in the entire transmission mechanism are first eliminated. Then, as the torque is increased, the metal of the transmission, framing, etc., is bent and twisted, or otherwise deflected. This stressed metal becomes a storage battery of energy. Finally the tractive effort reaches a value sufficient to overcome the existing adhesion at the rail (co-

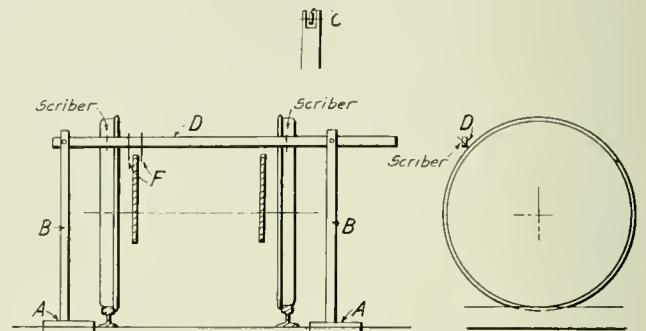

Fig. 2—Hand-operated Oscillograph for Recording Chattering Slip on the Wheel Tread

efficient of friction of repose), and the wheel starts to slip. The instant relative movement occurs between wheel and rail, the coefficient of friction drops from that of repose to that of relative motion. There is, therefore, an opportunity for the stressed metal to start discharging its stored energy, since part of the resisting force has disappeared. This energy is expended in accelerating the wheels ahead of the angular position they occupied relative to the rotor at the instant slipping started. Since the wheels are being accelerated ahead of the rotors, the rotors are losing their load and will tend to speed up.

Analyzing next the other division of the system, the adhesion at the rail will decrease as the velocity of the wheel tread relative to the rail increases. The effort being transmitted through the transmission system, however, will decrease very rapidly, due to expenditure of stored energy, and

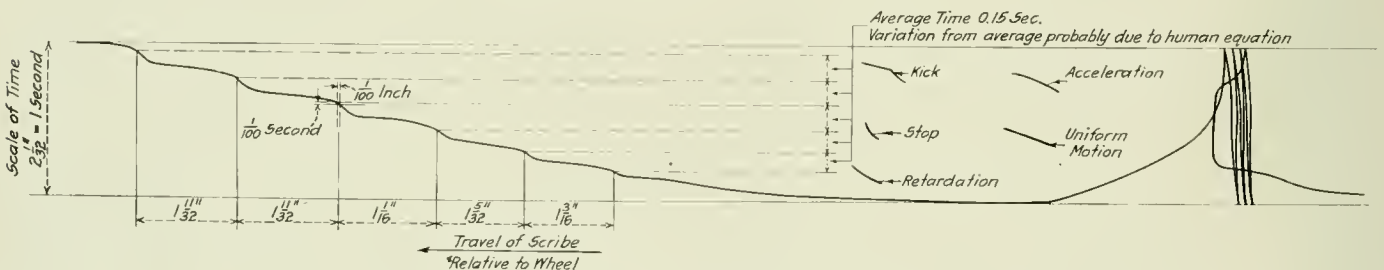

Fig. 1—Oscillograph Record of Chattering Wheel Slip Made Directly on the Wheel Tread

as soon as this effort, which is tending to accelerate the wheels, becomes less than the adhesion at the rail, which is tending to retard the wheels, the wheels will evidently start to slow down.

There are, then, two sets of rotating masses mechanically coupled, the masses at one end of the system accelerating and those at the other end retarding. As soon as clearances in the transmission are taken up, there is liable to be a jolt on the mechanical system, accompanied by a recoil. This

as soon as this effort, which is tending to accelerate the wheels, becomes less than the adhesion at the rail, which is tending to retard the wheels, the wheels will evidently start to slow down.

There are, then, two sets of rotating masses mechanically coupled, the masses at one end of the system accelerating and those at the other end retarding. As soon as clearances in the transmission are taken up, there is liable to be a jolt on the mechanical system, accompanied by a recoil. This

\*From a paper presented before the American Institute of Electrical Engineers in New York, February 9, 1916.

gives the setting for chattering action, and such action has been experienced in practically every type of electrically-driven rolling stock where the motors are sufficiently powerful to slip the wheels at high adhesion.

On the Norfolk & Western locomotives, after they had been in service for some months, evidences of failure were detected in the crank pins. The cause was traced to chattering slip by means of a rough oscillograph, as shown in Fig. 2. The brakes were set on three trucks, and the oscillograph frame was set up on the fourth truck. The wheel tread was chalked. The oscillograph frame was oscillated about its supporting points A, the amplitude of oscillation being two inches. The time of complete oscillation was two seconds. The scribes were pressed against the wheel treads, which were then slipped, and the characteristic diagram of the chattering slip was obtained, as showing in Fig. 1. The analysis in the figure is self-explanatory. By means of this diagram, it was possible to figure approximately the forces

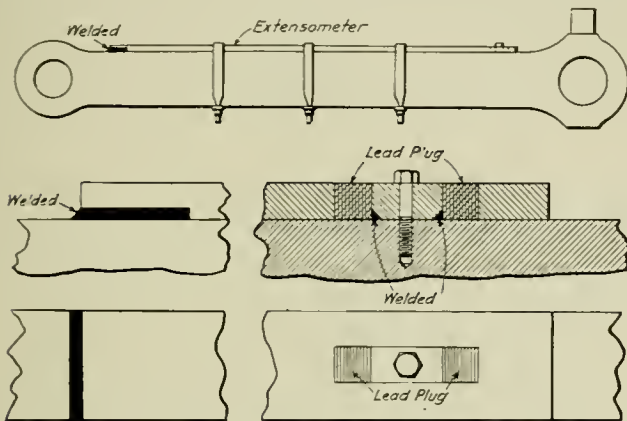

Fig. 3.—Details of Extensometers Used to Check the Oscillograph Figures

necessary to produce the acceleration and retardation which occurred, and the resultant stresses in the rods, pins, etc., were calculated.

To check the oscillograph figures, extensometers were arranged, as shown in Fig. 3, by means of which the connecting rods indicated their own stresses. The extension and compression of the rods were recorded by means of the compression of blocks of lead. The two methods checked within a very few per cent. On the basis of the results, new rods, pins, etc., were applied on the locomotives. These have proved adequate for the service.

This chattering slip was more evident on the Norfolk & Western locomotives than could have been anticipated, since this was the first time electric haulage had been applied in service where such extremely high tractive efforts were required.

**ANTIFRICTION A MISNOMER.**—Antifricition metals, so called, are useful for lining bearings chiefly because of the ease with which they can be formed (poured) and their ability to permit crushing and abrasion without great increase in friction, not because they have a lower coefficient of friction: hence antifricition is a misnomer.—*Power.*

**REMELTING BABBITT METAL CAUSES INFERIORITY.**—When babbitt metal has been remelted a number of times, it loses its fluidity, becoming more "pasty" or "mushy" the oftener it is remelted, and will not make as sharp, smooth and solid castings for bearings as when the metal is new. This probably is due to separation of the ingredient metals resulting from oxidation of those of lower temperature of fusion, when raised to much higher temperatures than may be necessary for the fusion of other ingredients.—*Power.*

## THE PREVENTION OF SPONTANEOUS COMBUSTION OF COAL

BY J. F. SPRINGER

Spontaneous combustion has been a source of much trouble and of considerable loss wherever coal has been stored in large quantities and many independent investigations have been made, all of which are in substantial agreement as to the underlying causes. In a previous article\* the writer has endeavored to set forth what these causes are and to outline the conditions favorable to ultimate self-firing.

From a practical standpoint one of the most important discoveries which has been made is that spontaneous combustion is due to accelerating oxidation and rise of temperature, the one activity continually boosting the other until actual ignition takes place. There are, accordingly, two remedies: first, to shut off the oxygen supply; second, to keep down the temperature.

The submergence of coal in water performs both of these functions. Bituminous coal stored under water, whether salt or fresh, is proof against self-firing. Submerged storage is further beneficial in that it preserves the thermal content and physical condition. New River, W. Va., coal,  $\frac{1}{4}$  in. in size, stored in salt water at Portsmouth, N. H.; Norfolk, Va., and Key West, Fla., either lost nothing at all of its heating value or the loss was less than .5 per cent. Similarly, the same coal of the same size, stored beneath fresh water at Pittsburgh, Pa., lost none of its heating value. In all of these cases the coal was stored two years. Parr and Hamilton in an investigation conducted under the auspices of a university in the middle west found that the heating value of submerged Illinois coals remained practically the same after a period of about nine months. All the coals were submerged when freshly mined, the interval between mining and submergence in no case exceeding one month. About the only objection to this method of storage seems to be that it requires the firing of wet coal. This is a real objection where Illinois and Wyoming coals are used, as they mechanically retain 5 to 15 per cent of water after draining. In the case of high-grade eastern coals, however, if firemen are permitted to wet down their coal before firing, in order, as some say, "to make a hotter fire," the addition during storage of the 2 or 3 per cent of moisture which these coals retain becomes of little consequence.

The capital outlay required to provide for submerged storage will differ with varying conditions. Where the storage is located on tide water or can be placed on the bank of a fresh water stream, the cost of construction would not appear to be necessarily unreasonable. On the other hand, where a special water-tight basin has to be constructed, the expense may be considerable.

The United States Government has wet storage in salt water in the new coaling stations at Cristobal and Balboa, Canal Zone. At the former station, which is the larger of the two, the capacity for wet storage will be about 100,000 tons. This will be for navy coal and not subject to the demands of commerce. The coal will be piled up above the sea level to a considerable height and there will be dry storage adjoining.

At a zinc smelting plant in Illinois consuming several hundred tons of screenings a day the problem of storage was solved by utilizing an abandoned excavation at a brickyard near by. The pit was 450 feet long, 250 feet wide and 45 feet deep. No lining aside from coal screenings at 45 cents a ton was found necessary and a storage basin for 100,000 tons was thus prepared at a very small outlay. The coal is delivered through a chute in which water is used to facilitate the movement and is recovered by a pumping operation. The total cost of handling, including interest and amortization on

\*See the *Railway Mechanical Engineer* for March, 1916, page 124.

the plant, the depreciation of the coal, etc., amounted to 22.5 cents per ton. The originator of this system states that experiments have shown that with properly designed equipment equally as good results may be obtained with coal not coarser than will pass through a 6-in. screen.

The use of carbon dioxide presents another possible means of cutting off the air supply from coal piles which might be applied under some conditions. Quantities of this gas are available in flue gases, which could be diverted and cooled. Its weight would then permit its use as a blanket over the coal pile to exclude the air, it being necessary, however, to provide a storage basin whose bottom and sides are air tight. Probably the greatest difficulty would be adequately to provide against dissipation of the carbon dioxide through the action of winds across the top of the storage basin.

The second remedy against spontaneous combustion seeks not to cut the air off but to supply it in quantity. Ignition will not take place until the temperature has risen to 600 deg. F. or higher. If the circulation of air is sufficient to carry away the heat liberated by the oxidation process oxidation may still continue, but will be slow and will not result in ignition. It has been suggested that the system of ventilation should be so arranged that the currents of air do not come in direct contact with the coal. In this way, the cooling effects may be obtained without exposing the coal to the oxygen supply in the flowing air.

Ventilation has been tried, apparently with some success, at Montreal in the 250,000-ton storage of the Canadian Pacific. That it is not always to be depended upon, however, may be illustrated by a case taken from experience in the Philippine Islands. A coal is mined on the island of Batan which changes its condition rapidly upon exposure to sun and air, losing its lustre and disintegrating into powder. Even in transit it is necessary to protect it from sun and wind to prevent this rapid alteration of condition. Several years ago 9,000 tons of this coal were stored by the Philippine civil government in piles about 15 ft. high, the piles resting on the ground and being protected by a roof. They were ventilated with alternate tiers of horizontal air passages, about 19 ft. 6 in. apart and at right angles to each other. The coal did not actually ignite, but the timbers used to make the ventilators were all badly charred.

So far our attention has been occupied with measures which are somewhat elaborate and expensive. It is, no doubt, often the case that nothing approaching any one of these remedies is practical. Perhaps the most important of the precautionary measures which must ordinarily be depended upon to prevent spontaneous combustion is to store the coal only in low piles. As already pointed out in the preceding article, the safe height will vary for different coals. Heights greater than 15 or 20 ft., however, are generally dangerous. Another precautionary measure is to avoid breaking up the coal when putting it into storage. The fracturing results in the exposure of fresh surfaces to oxidation. Fine coal produced by handling tends to run down into the interior of the pile and, especially when freshly broken up, is highly susceptible to oxidizing influences. Furthermore, the interior of the pile is the dangerous region.

More than ordinary care should be bestowed upon the storage of those coals which contain unsaturated compounds which are ready to absorb more oxygen. Although this process does not result in the formation of carbon dioxide, it nevertheless causes a rise in temperature. If the coal contains sulphur in the form of iron pyrites, another source of oxidation is present. The oxidation of iron pyrites is greatly accelerated when the coal is in a finely divided state and is also increased by the presence of moisture.

In a report on this subject by Porter and Ovitz, among other precautionary measures, it is recommended that coal should be rehandled and screened after the lapse of two

months, and that storage be delayed for a period of six weeks after mining to permit the coal to "season." Piling the coal in such a way that the lump and slack is distributed is also recommended. The lump should not be permitted to roll down from a peak to form air passages.

Where the water supply could be obtained by diversion from a nearby stream it might be practical under some conditions to provide a system of water cooling by means of pipes through the coal pile. The piping might be permanent and so arranged as to interfere but little with the recovery of the coal. Of systems which have actually been tried, however, submerged storage is the most important and best meets the requirements. Where submerged storage is not permissible, the best practice is to store in shallow piles, leaving frequent aisles between. As a means of frequently testing the temperature until the danger period is past, iron rods may be thrust down into the mass at various points. These should be pulled out and examined every few days until the temperature begins to drop. Where excessive heating or actual fire occurs, the very best method of attack is to dig out the heated coal. The use of water usually fails if the case of firing is really a bad one, because of the formation by the fire of a protective covering of coke which prevents the penetration of the water.

## FUEL ECONOMY ON THE ROCK ISLAND

W. J. Tellerton, general mechanical superintendent, Chicago, Rock Island & Pacific, in an article published in the March issue of the Rock Island Employees' Magazine, mentioned briefly the results of the systematic fuel economy campaign on that road and called attention to the possibility for further improvements. He said in part:

"The special department to effect economies in the consumption of locomotive fuel, under the general direction of the mechanical department, was organized in January, 1913. During the calendar year of 1915, as compared with the calendar year of 1912, on the basis of cost of fuel per 1,000 gross freight ton-miles, per 1,000 gross passenger ton-miles and per switch engine-mile, a reduction of \$1,010,681.84 was effected in the cost of locomotive fuel. I will not attempt to apportion the credit for this showing, as it was simply due to the co-operation of all employees, and they are to be congratulated on this excellent performance.

"There are still very large opportunities for making further substantial reductions in the cost of locomotive fuel. For instance, during the fiscal year ended June 30, 1915, in freight service there was an average consumption of 16 scoops of coal per engine-mile, in passenger service 7.4 scoops per engine-mile and 9 scoops of coal per switch engine-mile. If a reduction of only one scoop of coal per freight engine-mile and one-half a scoop of coal per passenger and switch engine-mile can be effected, the following annual saving would result:

Freight service, 131,022 tons.....	\$294,799.50
Passenger service, 67,496 tons.....	151,864.75
Switch service, 24,045 tons.....	54,101.25
	<hr/>
	\$500,765.50

"It is felt that with the continued co-operation of all concerned these figures could be exceeded. The main factors to be considered in accomplishing such a result are:

"Complete work reports by the engineers and prompt repairs by the roundhouse forces. This is also of vital importance in connection with the Federal requirements.

"Properly sized coal delivered to the locomotive tender.

"Locomotives should not be fired up an undue length of time in advance of the time they are needed, and care should be taken in building the fire.

"Proper instruction and co-operation of engine crews and terminal employees in the proper and economical performance of their duties."

# CAR DEPARTMENT

## QUALIFICATIONS AND TRAINING OF CAR INSPECTORS

BY MILLARD F. COX

The training of car inspectors does not vary materially from the training of men in every walk of life, for specific expert work; it is a process without short cuts. There was a time when nearly all railroad men were supposed to have been brought up through a long course of apprenticeship. These conditions have changed; all men nowadays are specialists, more or less. To say that a man can do anything is more than apt to create a doubt at once as to his ability.

In order to test the practicability of the system employed on the road with which I am connected, I sent a brief communication to one of our general car inspectors, asking him to answer a number of questions categorically. They are given below, with his replies:

- (1) *Where do we get our Car Inspectors?*  
As a rule we select from car repairers and car oilers the most intelligent and active man.
- (2) *How do they master the Rules of Interchange?*  
We supply them with the M. C. B. rules and instruct them to read and memorize them as much as possible.
- (3) *How are these men trained and developed?*  
When selected, we instruct a man in a general way what we expect of him, and that his continuance as an inspector will depend entirely on his conduct and the way he performs his duty. Then we place him in a location where there is more than one inspector working so that he is a constant partner or understudy to an experienced inspector. Later, when from daily observation we see that he is doing well, we can transfer him to a place where there is but one inspector.
- (4) *Do they get any special training?*  
As stated in No. 3, practical experience and such constructive criticism as from time to time may be rendered against or in favor of their work.
- (5) *What are the requisite qualities for a good inspector?*  
Honesty, sobriety, firmness of decision, loyalty, and intelligence.
- (6) *Should he be a mechanic?*  
This is not absolutely necessary if in train service, but in the shop or on new work, he should be a mechanic.
- (7) *What opportunity has he to advance in the service?*  
If in train service, he might from time to time advance to become a foreman of inspectors, or general inspector. If in the shop, to a gang foreman, shop or general foreman.

The necessary qualifications for a good car inspector might be enumerated at considerable length. The essentials are a clear head, an accurate memory, keen, quick eyes, and sound judgment. Without some of these, he cannot hope to reach any remarkable distinction. I once knew a man—the foreman of a large shop—who was one of the best organizers and disciplinarians I ever saw; and yet he was almost invariably under the influence of liquor. His legs were often shaky, but his head, never. Not many men

are so constituted, and it is just as well that they are not.

Sound judgment will almost stand for all the other essentials mentioned, if it is genuine. Sound judgment is common sense, and common sense is sometimes uncommonly scarce among inspectors, other than those who confine their efforts to cars. One of the most energetic inspectors I know is a man who knows everybody, much in general, and little about his own particular business. He could always tell what might, would or should happen, but when it did, his idea was the last to be accepted. His judgment is faulty.

The wide-awake, energetic inspector should be a man of ideas. Opportunities are now, and always will be open to the man with an idea, whether a car inspector or not. They need not necessarily be new, as all ideas are said to be "old things forgotten and found again." Such a man will be classed as a thinker, and the right word at the right time is effective. To think is to evolve, and if this process is repeated often and long enough, something will come to pass. A mechanical inspector without an idea is about as "dry pickings" as anything I know of.

The rules governing the interchange of cars are not as complicated as they will be. No normal human being can ever hope to be able to answer off-hand every question that arises regarding interchange; nevertheless, these rules must be studied and understood, or the inspector will lose his job, and before being discovered, damage the officer higher up. Therefore, he should have a clear head and accurate memory.

He will occasionally make a mistake, and when this occurs, it is ours to reason with him; and here is where he will prove himself if he is made of the right stuff. If by talking the matter over you find him nervous, high-strung, making you feel that you have not advanced a peg toward convincing him one way or the other, talking as it were in a circle, cut it short right then and there; you have struck a hopeless case. If on the other hand, he shows an inclination to prove his case calmly with facts and reason, showing an intelligent grasp of the meaning of the rules, encourage him.

Occasionally, superior men are discovered by accident. I once lost a very valuable foreman. He was so essential to our organization that I was puzzled for a while when he announced his intention of quitting. There did not seem to be one man in the department who could fill his place. In my dilemma, I appointed a man temporarily who, though a very skilled workman, had never shown one leadership trait. To my amazement, he seized this opportunity and in a short time had matters well in hand and proved entirely satisfactory. Here was a man so modest that it made his discovery well-nigh impossible. Our car inspectors must, when in the right, know how to assert themselves occasionally. Aggressiveness in an inspector is a fine quality; such a man never lets an obstacle go unsurmounted. If something unusual should get by him, he must be man enough to acknowledge it squarely, so as to be fully and clearly understood by his foreman. To go home after a long, strenuous day's work, feeling in your mind that however slow or plodding John seems to be, you know that whatever he tells you is absolutely correct, is a comforter of no mean proportions.

A car inspector's knowledge must be gained by hard study and close application, to be of real and lasting value to himself and to his employer.





# HOPPER COAL CARS FOR INDIA

Steel Equipment for Use on a Road With 5 ft. 6 in. Gage; Capacity, 94,000 lb.; Weight, 49,000 lb.

An interesting design of hopper coal car has recently been worked up by the Birmingham Railway Carriage & Wagon Company, Ltd., Smethwick, England, and 66 of these cars built for the Bengal-Nagpur Railway, which is a 5 ft. 6 in. gage road. The cars have a capacity of 94,000 lb. and a light weight of 49,000 lb.

The framing is built up mostly of structural shapes and plates, although pressed material is used in some instances. The side sills have 4 in. by 4 in. by  $\frac{5}{8}$  in. top and bottom angles with  $\frac{1}{2}$  in. web plates, and are 10 in. deep at the

The center sills are continued to a point 4 ft. beyond the center of the body bolster where they are connected to a  $\frac{3}{8}$  in. pressed transverse channel, this channel being at the hopper slope. Diagonal braces consisting of 9-in. by  $3\frac{1}{2}$ -in. 22.7 lb. bulb angles extend between the body bolsters and the buffers. The cars are braced from the sides of the body to the side sills by 4 in. by  $3\frac{1}{2}$  in. by  $\frac{3}{8}$  in. tees and at the center sills by 5-16 in. pressed plate gussets.

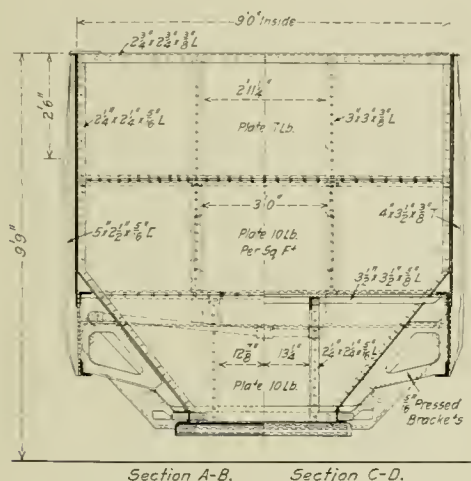

Section A-B. Section C-D.  
Cross Sections of the Hopper Car

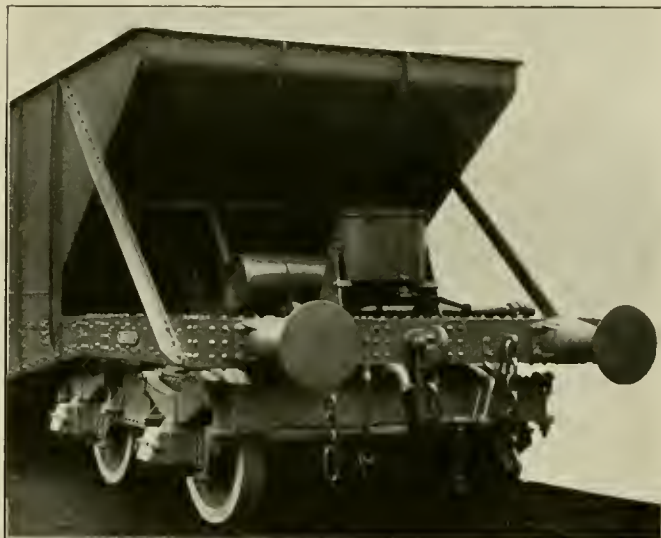

An End View of the Hopper Car

ends and 24 in. deep at the center, this depth being maintained for a distance of 10 ft. 9 in. The side stakes are 5 in. by  $2\frac{1}{2}$  in. by 5-16 in. channels and 4 in. by  $3\frac{1}{2}$  in. by  $\frac{3}{8}$  in. tees, the depth of the car side being 5 ft.  $8\frac{1}{2}$  in. The inside length of the car at the top of the hopper is 35 ft. and the top members of the body frame are  $2\frac{3}{4}$  in. by  $3\frac{3}{8}$  in. angles.

As will be seen from the illustrations, the car is so sup-

ported on the trucks that the hopper hangs between them and comes close to the track at the bottom. The center sills are 10 in. channels, weighing 19.85 lb. per ft. and extend between the  $3\frac{1}{2}$  in. by 10 in. channel end sill and the body bolster which is built up of 10 in., 30 lb. channels and top and bottom cover plates 28 in. by 5-16 in.

The trucks are of a built up type, the frame used being made of  $\frac{5}{8}$  in. plates with channel transoms and end sills. They have 37 in. diameter wheels and a wheel base of 6 ft., the distance between the center pins being 29 ft. 3 in. The hopper doors are operated horizontally by racks and pinions through the medium of Brampton's rail chains which are



Steel Hopper Car Built in England for the Bengal-Nagpur Railway

ported on the trucks that the hopper hangs between them and comes close to the track at the bottom. The center sills are 10 in. channels, weighing 19.85 lb. per ft. and extend between the  $3\frac{1}{2}$  in. by 10 in. channel end sill and the body bolster which is built up of 10 in., 30 lb. channels and top and bottom cover plates 28 in. by 5-16 in.

enclosed in special cases, the gearing being operated by hand wheels on either side of the car. The brakes are of the combined vacuum and hand lever type, having 21-in. cylinders with separate 14 in. diameter vacuum chambers. Both brakes operate on all the wheels of the car.

The cars were tested with a load of 179,000 lb. or 44,800

lb. per axle without any trouble resulting. The following table gives a list of the principal dimensions:

Length over buffers.....	44 ft. 11 in.
Length over end sills.....	40 ft. 9 in.
Length of body.....	35 ft.
Width of underframe.....	9 ft.
Centers of trucks.....	29 ft. 3 in.
Wheels, diameter.....	3 ft. 1 in.
Wheelbase of trucks.....	6 ft.
Buffer height (unloaded).....	3 ft. 7½ in.
Journals.....	5½ in. by 10 in.
Hopper doors openings.....	42 in. by 42 in.
Centers of hoppers.....	10 ft. 9 in.
Height of car from rail.....	9 ft. 9 in.
Weight.....	49,000 lb.
Capacity.....	94,000 lb.

**TABLES FOR DETERMINING THE MOMENT OF INERTIA OF RECTANGLES**

BY C. H. FARIS

Since the recommendation of the committee on car construction of the Master Car Builders' Association that the minimum strength for steel underframes be determined on the basis of the stress to end load in the center sills, frequent investigations are required to determine whether certain designs will meet the requirements outlined by the committee. Such investigations, as well as any investigation of

to simplifying the computations necessary to determine the moment of inertia of sections which are treated in the manner outlined above. In Table I are given the values of  $h^3$  for values of  $h$  from zero to 13 by sixteenths of an inch, Table II containing similar information for values of  $h$  from 14 in. to 41-7/8 in., varying by eighths of an inch. By using the tables the moment of inertia of any rectangle can be found by simply multiplying the tabular value corresponding with the height of the rectangle by its breadth.

The tables may be applied to the finding of the moment of inertia of a triangle by the use of the formula shown in Table II. For ordinary use the values for intermediate heights may be obtained with sufficient accuracy by interpolation between the values given in the tables.

**FIRE DAMAGE TO ELECTRIC GENERATORS.**—The chances of generators of the older types being seriously injured by fire in the event of some part of the insulation failing are slight. Their freedom from fire damage is due principally to the comparatively low speeds, the accessibility of the combustible insulation, and the large mass of the machines per unit of capacity. In the case of generators of the turbo type this condition is reversed. Undoubtedly manufacturing companies have given the subject serious thought, but there is still very

TABLE I

Moments of Inertia of Rectangles for variable depth  $h$  and breadth  $b = 1$

	0	1	2	3	4	5	6	7	8	9	10	11	12	13
0	.....	.08333	.66667	2.2500	5.3333	10.417	18.000	28.583	42.667	60.750	83.333	110.92	144.00	182.08
1/16	.....	.00002	.09996	.73114	2.3936	5.5873	10.812	18.568	29.356	43.674	62.024	84.906	112.82	146.26
1/8	.....	.00016	.11865	.79964	2.5431	5.8491	11.218	19.149	30.142	44.698	63.316	86.498	114.74	148.55
3/16	.....	.00055	.13955	.87229	2.6988	6.1190	11.633	19.741	30.942	45.738	64.627	88.109	116.69	150.86
1/4	.....	.00130	.16276	.94922	2.8607	6.3971	12.059	20.345	31.757	46.793	65.954	89.741	118.65	153.19
5/16	.....	.00254	.18842	1.0305	3.0289	6.6835	12.494	20.961	32.585	47.865	67.300	91.393	120.64	155.54
3/8	.....	.00439	.21663	1.1164	3.2036	6.9784	12.941	21.590	33.428	48.952	68.665	93.064	122.65	157.93
7/16	.....	.00698	.24754	1.2068	3.3849	7.2817	13.397	22.232	34.284	50.056	70.047	94.756	124.68	160.33
1/2	.....	.01042	.28125	1.3021	3.5729	7.5937	13.865	22.885	35.156	51.177	71.448	96.469	126.74	162.76
5/8	.....	.01483	.31789	1.4022	3.7678	7.9146	14.343	23.552	36.042	52.314	72.867	98.202	128.82	165.21
3/4	.....	.02034	.35758	1.5073	3.9696	8.2443	14.832	24.231	36.944	53.468	74.306	99.955	130.92	167.69
7/8	.....	.02708	.40046	1.6176	4.1784	8.5831	15.331	24.924	37.859	54.639	75.762	101.73	133.04	170.20
1	.....	.03516	.44662	1.7331	4.3945	8.9310	15.842	25.629	38.790	55.827	77.238	103.52	135.19	172.72
1 1/16	.....	.04470	.49620	1.8539	4.6179	9.2882	16.365	26.347	39.736	57.032	78.733	105.34	137.35	175.28
1 1/8	.....	.05583	.54932	1.9803	4.8488	9.6548	16.898	27.079	40.698	58.254	80.247	107.18	139.55	177.85
1 1/4	.....	.06866	.60610	2.1123	5.0872	10.031	17.443	27.825	41.674	59.493	81.781	109.04	141.76	180.46

Multiply the tabular value for the given depth by the given breadth to get the required moment of inertia of any rectangle.

TABLE II

	14	15	16	17	18	19	20	21	22	23	24	25	26	27
0	228.67	281.25	341.33	409.42	486.00	571.58	666.67	771.75	887.33	1013.9	1152.0	1302.1	1464.7	1640.2
1/8	234.85	288.34	349.40	418.51	496.20	582.94	679.24	785.61	902.54	1030.5	1170.1	1321.7	1485.9	1663.1
1/4	241.14	295.55	357.58	427.75	506.53	594.44	691.98	799.64	917.93	1047.3	1188.4	1341.5	1507.3	1686.2
3/8	247.54	302.88	365.90	437.11	517.01	606.10	704.87	813.84	933.49	1064.3	1206.8	1361.6	1529.0	1709.5
1/2	254.05	310.32	374.34	446.61	527.64	617.91	717.93	828.20	949.22	1081.5	1225.5	1381.8	1550.8	1733.1
5/8	260.68	317.89	382.92	456.25	538.40	629.87	731.14	842.73	965.13	1098.8	1244.4	1402.2	1572.9	1756.8
3/4	267.42	325.58	391.62	466.03	549.32	641.98	744.51	857.43	981.21	1116.4	1422.8	1595.1	1780.8	1804.9
7/8	274.28	333.40	400.45	475.95	560.38	654.24	758.05	872.30	997.48	1134.1	1443.6	1617.6	1804.9	
28	1829.3	2032.4	2250.0	2482.6	2730.7	2994.7	3275.3	3572.9	3888.0	4221.1	4572.7	4943.2	5333.3	5743.4
18	1853.9	2058.8	2278.2	2512.7	2762.8	3028.9	3311.6	3611.3	3928.6	4264.0	4617.9	4990.9	5383.5	5796.1
14	1878.8	2085.4	2306.7	2543.1	2795.2	3063.3	3348.1	3650.0	3969.6	4307.2	4663.5	5038.9	5434.0	5849.1
10	1903.8	2112.3	2335.4	2573.8	2827.8	3098.0	3384.9	3689.0	4010.8	4350.7	4709.4	5087.2	5484.7	5902.5
12	1929.1	2139.4	2364.4	2604.7	2860.7	3132.9	3422.0	3728.2	4052.3	4394.5	4755.6	5135.8	5535.8	5956.1
16	1954.6	2166.7	2393.6	2635.8	2893.8	3168.1	3459.3	3767.8	4094.0	4438.6	4802.0	5184.7	5587.3	6010.1
20	1980.3	2194.2	2423.0	2667.2	2927.2	3203.6	3496.9	3807.6	4136.1	4483.0	4848.8	5234.0	5639.0	6064.4
24	2006.2	2222.0	2452.7	2698.8	2960.8	3239.3	3534.8	3847.6	4178.4	4527.7	4895.9	5283.5	5691.0	6119.0

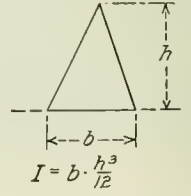
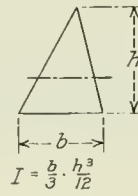
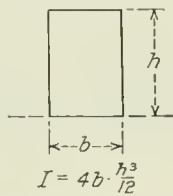
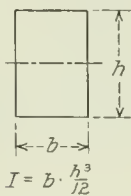

the properties of other sections in an analysis of the stresses in steel car members, usually involves the tedious computation of the moment of inertia of a number of rectangles into which a diagram of the section has been divided.

The accompanying tables have been prepared with a view

much to be desired. Besides improving the non-combustible properties of the coverings, it would seem feasible to provide means for cutting off the ventilating system and thus diminish the supply of oxygen, or even to introduce CO<sub>2</sub> in the place of air in the cooling system.—*The Engineer.*



delegating competent men to make periodical checks of the work performed by each inspector or repairman at all yard repair points. These investigations should be in the nature of a surprise check in order to realize the best results.

Another feature in connection with the supervision of repairs to foreign cars which may be productive of splendid results if handled along the proper lines, is the centralizing of M. C. B. billing work at one point on a system. Where the centralization idea is carried out and the billing repair cards from all points on the system are forwarded to one central office, a great deal of valuable information reflecting the condition as well as the practices at the various repair points, can be obtained by carefully analyzing the character of the charges, the reasons shown for making the repairs, etc. In other words, where this system is in effect the billing repair cards covering the charges against two or three roads, selecting different roads each month, should be sorted out by stations before the bill is rendered. This will permit of a careful comparison of the work performed at the various repair points and will readily disclose a tendency on the part of one point toward specializing on certain items of repairs, the use of stereotyped terms in designating reasons for repairs, etc. Where such tendencies are apparent, an immediate investigation can be made with a view to determining whether or not there is any special reason for such conditions existing, and, if necessary, corrective measures can be applied. Briefly, the plan outlined will enable those in charge of the M. C. B. work to keep in close touch with the conditions that obtain over the entire road. It is, of course, the general practice of roads to analyze the bills rendered against them somewhat along the plan as outlined above, and, while this is necessary, it is equally as important, and in fact the duty of every road, to make a similar study of their own charges.

Of equal importance to the question of providing for adequate supervision, is that of providing for suitable original records, for the reason that upon the correctness of the original record depends largely the correctness of the billing repair card. This card is the basis for the exchange, monthly, of large sums of money between the railroads of the country, and in an endeavor to bring out what may be

inspector's record blank, shown in Fig. 1. This form has been adapted not only to a record of repairs, but also shopping records, interchange records, and in fact any inspection record which an inspector may be called upon to make. As the note at the bottom of the blank explains, the word "Defects" shown at the top of the center column, is marked out when it is used as a record of repairs; likewise, the word "Repairs" is marked out when the blank is used as a record of defects. A space is also provided for showing the reason for making repairs, and the detailed instructions which govern the use of this form emphasize the importance of showing in the space referred to the *actual reasons for* making the repairs; in other words, the practice of using stereotyped terms is positively prohibited and no report covering repairs is acceptable unless the reason for making them are shown.

Attention is particularly drawn to the extreme right-hand

M. P. 310 a  
PENNSYLVANIA RAILROAD COMPANY  
Philadelphia, Baltimore & Washington Railroad Company  
West Jersey and Seashore Railroad Company

Report of change of Wheels and Axles at \_\_\_\_\_ Date \_\_\_\_\_ 191\_\_

Initial \_\_\_\_\_ No \_\_\_\_\_ Kind \_\_\_\_\_ Capacity \_\_\_\_\_ Load Weight I \_\_\_\_\_  
Max Wt \_\_\_\_\_ Load Weight II \_\_\_\_\_

WHEELS AND AXLE REMOVED

MAKER	Ry. Car & Initial	Wheel No.	Dia. Car	Kind	Size	Cause of Removal	SERVICE METAL	
							Before Turning	After Turning

AXLE: Size of Journal \_\_\_\_\_ Dia. of Wheel Fl. \_\_\_\_\_ Dia. of Center \_\_\_\_\_ Cause of Removal \_\_\_\_\_ Are Wheels Greased? \_\_\_\_\_

WHEELS AND AXLE APPLIED

MAKER	Ry. Car & Initial	Wheel No.	Dia. Car	Type of Flange	Kind	Size	Service Metal

AXLE: Size of Journal \_\_\_\_\_ New or 2d Hand \_\_\_\_\_ Location \_\_\_\_\_

Loaded or Empty \_\_\_\_\_

Inspector \_\_\_\_\_

Fig. 4—Shop Record of Wheels and Axles Changed

column under the heading "N. B. or B. O." The letters "N. B." stand for the words "No bill," while the letters "B. O." represent the words "Bill owners." This column may not, at first thought, appeal to many as being very important; yet it was incorporated in this form in order to carry out the idea of having a record from which the billing repair card can be prepared without any assumption whatever on the part of the person making up the billing repair card, as to whether or not any item of repairs is chargeable to car owners. For example, an inspector or yard repairman might have occasion to replace roofing boards that had been damaged on account of being cornered or raked, and if he was not required to specify whether these repairs should be considered "No bill" or "Chargeable to car owners," he might merely show on his record that the boards were broken and in the absence of any other information the repairs may be charged against the car owner. It is well known that inspectors not engaged in interchange inspection, or, in other words, those that handle ordinary train inspection or repairs, in many instances do not attempt to familiarize themselves with the M. C. B. rules insofar as differentiating between handling line's and owner's defects; and, therefore, they may fail to show the necessary information on their records that will enable the person preparing the billing repair card to make proper disposition of the charge. Therefore, by requiring each inspector or repairman to determine the responsibility and indicate it by proper designating marks on their records, they are compelled to study the rules and will naturally develop into more efficient inspectors, and the records will be more reliable.

Another requirement in connection with the use of this form is that each repairman must make his own record of the repairs he makes and his personal signature must appear in the space provided for it. This requirement is considered

REPAIRS REQUIRED.

101

Inspector \_\_\_\_\_

Renew	Replace	Partly R. & R.	Frame	Cause of Damage	Class of Car _____ Cap'y of Car _____	Tolls	Credits	Miles

Fig. 3—Reverse Side of Repair Card Shown in Fig. 2

considered some of the most essential points that should be covered by original records, the forms that are used in yards, as well as on shop and repair tracks on the Pennsylvania Railroad, have been incorporated in this paper.

Original records may be divided into two general classes: Yard Inspector's or Repairman's Record and Shop or Repair Track Record.

On account of the conditions previously outlined under which repairs are made to foreign cars in yards, it is apparent that special consideration should be given to providing a suitable record blank for this work. This blank should be so designed that the repairman, when he has filled in the information called for, will have a record that will show all the information necessary for the preparation of the billing repair card.

It may be interesting to consider for a moment the car

very important and, in fact, necessary in order to obtain a reliable record, for the reason that it eliminates the undesirable practice that is frequently followed where one man is permitted or required to take the records for several men working in the same gang. Where the latter practice obtains, there is a possibility that the man held responsible for keeping this record will take a record covering certain items of repairs before the repairs are actually made, with the result that if, for any reason, the repairman fails to make the repairs, an improper charge is rendered against the car owner. Another advantage in connection with requiring each man to take his own record, is that he can be held individually responsible not only for the repairs, but also for the record.

The detailed requirements as just outlined are absolutely

**THE PENNSYLVANIA RAILROAD COMPANY**  
REPORT OF WORK PERFORMED MATERIAL AND LABOR AT TEST RACK, ON TRIPLE VALVES, REMOVED FROM FOREIGN CARS

Initials \_\_\_\_\_ Car Number \_\_\_\_\_ Date \_\_\_\_\_  
 Repairman \_\_\_\_\_ Shop \_\_\_\_\_ Make and Type \_\_\_\_\_  
 Initials of Road and Date of Last Previous Cleaning \_\_\_\_\_  
 Why sent to Test Rack \_\_\_\_\_

Slide Valve Spring \_\_\_\_\_ Emergency Valve Piston \_\_\_\_\_  
 Graduating Valve Spring \_\_\_\_\_ Check Case \_\_\_\_\_  
 Graduating Valve Stem \_\_\_\_\_ Check Case Gasket \_\_\_\_\_  
 Cylinder Cup Gasket \_\_\_\_\_ Check Valve \_\_\_\_\_  
 Emergency Valve \_\_\_\_\_ Check Valve Spring \_\_\_\_\_  
 Emergency Valve Brass Seat \_\_\_\_\_ Bolts and Nuts \_\_\_\_\_  
 Emergency Valve Rubber Seat \_\_\_\_\_ Studs \_\_\_\_\_

Repairs could not be made at Test Rack, sent to \_\_\_\_\_ Shop \_\_\_\_\_  
 Date \_\_\_\_\_ 191 \_\_\_\_\_ for \_\_\_\_\_ Repairs \_\_\_\_\_  
 \_\_\_\_\_ Test Rackman

Fig. 5—Record of Triple Valve Repairs

essential to a complete and correct record; and when proper consideration is given to the fact that the original record of repairs made is the basis for a charge against the car owner, too much importance cannot be attached to the question of providing suitable forms. This particular blank is gotten out in books of one hundred, and the blanks covering an inspector's records for a day are removed from the book and turned into the office at the close of the day. It thus has an advantage over a book record, for the reason that where a book record is used, the inspector must necessarily carry the book until it is entirely filled, with the result that it may become lost, and as is frequently the case, some of the records become blurred and illegible. Further, this blank is convenient for filing, as it can be filed either with the repair cards covering the repairs enumerated on the individual blank, or it can be filed separately, keeping each day's records together, either of which methods permits of ready reference.

Shop or repair track records are to a certain extent governed by the requirements of the various roads, and while there are not the same possibilities for improper records on shop or repair tracks as there are in C. T. yards, the fact that the former embraces more extensive, as well as a varied class of repairs, makes it necessary that a thorough system for keeping records of this branch of the work be provided.

Fig. 2 shows one side of our repair card on which is recorded each operation performed, the reasons for making the repairs and the price paid the workman for the operation. The same instructions obtain with reference to using the actual reasons for making the repairs on this form as were previously outlined in connection with the car inspector's record blank. All the information shown on this form is filled in by the piece-work inspector, who outlines the work to be performed, and who also checks the work after it is completed; and the piece-work inspector is held personally responsible for showing the correct reasons for making the

repairs, as well as the operations which were performed.

Fig. 3 shows the opposite side of this shop repair card, the particular feature of which is that the piece-work inspector, or, in some instances, the gang leader, is required to enumerate thereon all material used in connection with the operations that are shown on the reverse side of the card. The advantage of this method is obvious as the person preparing the billing repair card does not have to draw his own conclusion by referring to the labor operations in order to determine definitely the amount, kind or size, of material used; in other words, the person who is in the best position to know the actual operations performed, as well as the material used, namely the piece-work inspector or gang leader, is held responsible for completing this record, and therefore responsible for the charge thus made against the car owner. An additional requirement in connection with completing this report is that the piece-work inspector is required to show whether the items of labor, as well as the items of material, are chargeable to the car owner. This is accomplished by separating the chargeable items from those that are not chargeable, the former being shown under the caption "Bill owners," and the latter under the caption "No bill." Thus we have a complete record from which a billing repair card can be prepared without any question as to the proper disposition of each item of repairs.

The next record to which attention is directed is shown in Fig. 4, which is a shop record of the change of wheels and axles. It will be understood that the shop repair card Fig. 2

**PENNSYLVANIA RAILROAD COMPANY**  
PHILADELPHIA, BALTIMORE & WASHINGTON RAILROAD COMPANY  
 NORTHERN CENTRAL RAILWAY COMPANY  
 WEST JERSEY & SEASHORE RAILROAD COMPANY

M. P. S. 774 C 2-16-13  
2 2 1/2

\_\_\_\_\_ Westinghouse—New York Type Triple Valve Removed  
 \_\_\_\_\_ 191 \_\_\_\_\_ From \_\_\_\_\_ Car Number \_\_\_\_\_  
 at \_\_\_\_\_ Shop \_\_\_\_\_  
 Date and Initial last Cleaned and Oiled \_\_\_\_\_  
 \_\_\_\_\_ Foreman \_\_\_\_\_

ABOVE TO BE FILLED BY SHOP REMOVING VALVE

	REPAIRS MADE	WHY MADE
Triple Valve Body		
Cylinder Bushing		
" Cap		
" Gasket		

Side		
Front "		
" " Gasket		
Slide Cup		
Cap Screw		
Half Inch Plug		
Exhaust Outlet Plug		

Repaired \_\_\_\_\_ 191 \_\_\_\_\_  
 To be sealed in check case. \_\_\_\_\_ Foreman \_\_\_\_\_

Fig. 6—Another Form Used in Connection with Triple Valve Repairs

merely covers the labor operation for the exchange of wheels, the reasons for repairs and the kind and amount of material used; whereas, the form shown in Fig. 4 supplements the repair card by showing all of the detailed information that is necessary for preparing the wheel and axle billing repair card. This record is prepared either by the piece-work inspector in direct charge of the repairs, or by a special man who is detailed to check up the condition of the wheels and axles removed, as well as those applied; except that the amount of service metal before and after turning on wrought steel wheels is determined at the wheel shop when the wheels are turned. This part of the information is obtained by a report being forwarded to the foreman of the wheel shop covering each pair of wrought steel wheels removed, the wheels also being properly tagged for identification. When the wheels arrive at the wheel shop the amount of service

metal is carefully measured before turning and again after turning, and the measurements thus taken are promptly reported to the foreman under whose jurisdiction the wheels are removed. The latter then inserts this information on the wheel and axle report and the wheel shop report is attached to the wheel record as a part of the permanent file. However, before filing, the billing repair card is prepared from the information shown on both the wheel report, Fig. 4, and shop repair card, Fig. 2.

The question of providing suitable forms for keeping record of triple valve repairs is an important one and therefore merits a few moments consideration. Fig. 5 is a facsimile of our form M. P. 298, which is intended to take care of repairs made to triple valves at test racks. The information called for on the upper portion of the form is filled in by the repairman who removes the triple valve from the car. The form is then inserted in the check valve case and the triple valve, after being either tagged or marked so that it can be readily identified at the test rack as a foreign triple valve, is sent to the test rack, where it is given preference over triple valves removed from system cars in order not to incur any unnecessary delay in preparing the billing repair card. The test rack man removes the form from the valve, and in cases where the repairs needed are of such a nature that they can be performed at the test rack, he indicates just what repairs are made, as well as the reasons for making them, on the blank line opposite the items that are involved. The form is then signed by the man in charge of the test

**THE PENNSYLVANIA RAILROAD COMPANY**  
P. O. BOX 1111, WASHINGTON, D. C.

M. P. 298  
© P-6-12-1111  
1915

Mr. \_\_\_\_\_, Alltoona, Pa. \_\_\_\_\_ 191\_\_\_\_\_

Dear Sir: Please refer to attached Repair Card showing repairs made to \_\_\_\_\_  
car No. \_\_\_\_\_ at \_\_\_\_\_ date \_\_\_\_\_ 191\_\_\_\_\_, and furnish information asked for below.

RETURN THIS FORM WITH CORRECTED CARD AND YOUR EXPLANATION SHOWN BELOW

Yours truly,  
J. T. WALLIS,  
General Supt. Motive Power.

Fig. 7—Form for Securing Additional Information

rack and forwarded to the foreman under whose jurisdiction the triple valve was removed. The foreman, in the meantime, is holding the shop repair card, Fig. 2, which covers the work performed at the car, and upon receipt of the test rack report he has all the necessary information to complete the billing repair card.

There are many triple valves, of course, which require repairs that are not ordinarily made at a test rack located adjacent to repair tracks. When the test rack man finds a valve that he cannot repair, he shows on the bottom of Fig. 5 the shop to which the valve is to be sent for repairs, the date, and the principal defect that necessitates sending the valve to the machine shop. After placing his signature on this form, it is forwarded immediately to the foreman under whose jurisdiction the valve was removed. The latter then prepares a billing repair card covering the test rack repairs, as well as the repairs made at the car, as shown on the shop repair card, Fig. 2, or the yard report, Fig. 1. This billing repair card is marked with the notation "Bill for repairs to follow." In order that the additional repairs to the triple valve may be obtained, the test rack foreman, before forwarding his report, Fig. 5, to the shop foreman, fills in the information called for at the top of form M. P. 8 Fig. 6. This form is inserted in the check valve case and the triple valves forwarded to the designated shop. After the repairs have been completed, the items of repairs, as well as the reasons for making them, are filled in on Fig. 6, which is then sent to the foreman holding the original record, Fig.

2 or Fig. 1, for his information in preparing the billing repair card for the additional repairs. In each case the original record, Fig. 2 or Fig. 1, is filed with the test rack report, Fig. 5, and the machine shop report, Fig. 6, when the latter is used. Thus we have a complete record of the entire transaction. It might be well to state in this connection that each form illustrated is supplemented by printed detailed instructions. Likewise, the entire subject of handling repairs to foreign cars and the preparation of charges for them is outlined by printed instructions. The particular advantage in issuing printed instructions is that every detail of the subject is presented to each individual employee who has to do with the handling of this work, without any possibility of the meaning or intent of the instructions being obscured by change of language or errors in transcribing, which conditions frequently obtain where instructions are issued through the usual channels by letter. Further, the printed instructions can be more readily filed for convenient reference.

After a complete and adequate system of original records has been provided for, as well as explicit instructions concerning their use, there is one more step that must be taken to insure correct charges, viz.: to institute frequent checks both of the work being performed and the records at all repair points, in order to see that every detail of the instructions is being fully complied with. Such checks are absolutely essential for the reason that no matter how efficient a system of records may be, or how explicit are the instructions, the results desired cannot be obtained if the supervision is neglected.

The most important, or rather the essential features that should be covered by the original records, may be summed up briefly, as follows:

1. Yard records should not be made until after the repairs have been completed and should be prepared and signed by the person performing the work.
2. Shop or repair track records should be checked against the repairs made after the work has been completed.
3. All material used in connection with labor performed should be itemized on shop or repair track records, care being exercised to show the proper description of the material, as required by the M. C. B. rules.
4. All items of both labor and material that are properly chargeable to car owners under the rules should be separated from the items that are not chargeable to car owners and a suitable designating mark or phrase used to show responsibility.
5. The actual reasons for making the repairs should also be shown on the original records and the use of stereotyped terms prohibited.

After disposing of the question of original records, the preparation of the M. C. B. building repair cards is a comparatively simple matter. However, there are a number of points in connection with this phase of the work which cannot be overlooked, the most important of which, without doubt, is to see that the information on the billing repair card coincides in every detail with that shown on the original record; and further, the man preparing the billing repair card should not be permitted to draw his own conclusions as to labor performed, amount and kind of material used, or reasons for making the repairs. In other words, if and details of these essential points are not clearly shown on the original record, the latter should be returned to the man preparing it for correction. If this plan is closely adhered to, a great many of the troubles experienced in connection with M. C. B. billing will be eliminated.

After the items of labor and material have been entered upon the billing repair card, the next step to consider is the details of the charges, viz.: weights, quantity and value of material, and labor allowances. It is the practice of some roads to enter these details on the billing repair card at cen-

tral or division offices; but the practice that is followed on the Pennsylvania Railroad of completing every detail of the charge in the office of the foreman under whose direct charge the repairs are made, has many advantages which may be summarized, as follows:

1—The shop people, by being required to complete all details of the charges, must necessarily become close students of the M. C. B. rules with reference to responsibility for repairs, and particularly with the prices for labor and material, and where the men preparing the billing repair cards do not have this knowledge, the card frequently is not intelligently prepared, with the result that it is difficult to determine what the proper material or labor charges should be.

2—Where the billing repair card is completed in all details in the shop where the work is performed, the record repair card necessarily shows all this information, and exact duplicates of the original can be obtained at any time.

3—This method results in the training of an efficient corps of M. C. B. clerks over the entire system, from which vacancies in the general office, where expert M. C. B. men are necessary, can at all times be filled.

4—The handling of the billing at the general office is greatly facilitated, as the necessity for returning the cards to the shop for additional information or correction is minimized.

In order to effectively carry out the idea of completing the billing repair card at the shop, it is necessary that the billing repair cards be forwarded daily, direct to the central office where they should be immediately and carefully checked. Any errors that are detected or additional information that may be required should be handled direct with the foreman whose name appears on the billing repair card, instead of such communications following the regular channel, as is provided for by the organization of the road. The advantage of this is obvious, for the reason that, in addition to getting quick results, a great deal of unnecessary work in the office of the superintendent of motive power, master mechanic or general foreman, is eliminated.

A convenient and efficient method of communicating with the shop foreman is by the use of a form similar to that shown in Fig. 7. The clerk who finds an error or insufficient information on a billing repair card indicates, in the space provided, the information desired. This form is filled out in duplicate, the original attached to the billing repair card which is to be returned and the carbon copy held, by the clerk who checks the charge, until a reply is received. It is advisable in the majority of cases to return the billing repair card to the shop for correction where it would necessitate an erasure of certain information, if the correction were to be made in the central office. However, in cases where it is not objectionable to make a correction on the billing repair card before the bill is rendered, the correction may be made at the central office, but the shop should be advised of the correction made by the use of the form referred to, so that they can correct their record repair card and be in a position to avoid similar errors in the future.

A very important factor that contributes greatly to the rapid and accurate checking of charges on the billing repair card is that of itemizing on the extreme right-hand margin the labor allowances for each item of labor appearing on the repair card, instead of merely showing the total hours labor on the card. This not only facilitates the work in the central office of the billing road, but also enables the car owner to readily see how the total labor charge has been determined, and consequently materially assists in minimizing correspondence between the car owners and the road rendering bill.

There are, of course, other details in connection with this subject that could be commented upon, but those already

covered will present the essential points that may be considered necessary to obtain an efficient and reliable system for handling foreign car repairs and the preparation of charges for the work performed.

### DESIGN OF PASSENGER EQUIPMENT

BY VICTOR W. ZILEN

Associate, American Society of Mechanical Engineers

#### IV

##### BRAKE SHOE SUSPENSION

In keeping pace with the increasing weight of cars, brake shoe loads have reached a point to exceed which results in the melting of the brake shoe metal. In what follows it is the purpose of the writer to show how a destructive pressure may be brought against a portion of the surface of the brake shoe when the total load is well within the capacity of the shoe if properly distributed by a correct suspension of the brake head.

In Fig. 5 *K-M* represents a four-wheel truck with inside hung brake shoes suspended from a point above the center line of brake head; *L-N* shows the brake shoes suspended from a point below the center of brake head.

- Let *P* = brake shoe load, normal to the wheel
- V* = frictional force between shoe and wheel, having for its reaction *R* at *E*
- A* and *B* = reactions of the brake shoe load *P*
- A*<sub>1</sub> and *B*<sub>1</sub> = reactions of the pressure produced by the force *V*, which tends to crowd the shoe against the wheel by turning it about the point *E*; the intensity of this pressure is evidently  $\frac{Vb}{c}$

- A*<sub>t</sub> and *B*<sub>t</sub> = total brake shoe pressure at top and bottom respectively
- f* = coefficient of brake shoe friction.
- V* = *fP*

Taking moments about *D* (Fig. 5 *K*) we have for the algebraic sum

$$Pd + Va + Ah - Bg = 0, \text{ or } B = \frac{Va + Pd + Ah}{g}$$

and for equilibrium of translation

$$B = P - A$$

By substituting for *V* its value, *fP* and transposing the following values are found:

$$A = \frac{P(g - d - fa)}{h + g} \dots\dots\dots (50)$$

$$B = P \frac{(h + d + fa)}{h + g} \dots\dots\dots (51)$$

Taking moments about *E*, we have

$$A_1(c - h) + B_1(c + g) - Vb = 0 \text{ or } B_1 = \frac{Vb - A_1(c - h)}{c + g}$$

and for equilibrium of translation

$$\frac{Vb}{c} - (A_1 + B_1) = 0, \text{ or } B_1 = \frac{Vb}{c} - A_1$$

Solving these equations and substituting for *V*, its value, *fP* the following equations are obtained:

$$A_1 = \frac{fPbh}{c(h + g)} \dots\dots\dots (52)$$

$$B_1 = \frac{fPbh}{c(h + g)} \dots\dots\dots (53)$$

Then the total pressure at the top and bottom of the brake shoe will be respectively

$$A_t = \frac{P}{h + g} \left( g - d - fa + \frac{fbg}{c} \right) \dots\dots\dots (54)$$

$$B_t = \frac{P}{h + g} \left( h - d + fa + \frac{fbh}{c} \right) \dots\dots\dots (55)$$

By the same process it will be found that the values of *A*<sub>1</sub> and *B*<sub>1</sub> in Fig. 5 *L* are the same as those shown in equations (52) and (53), while the values of *A* and *B* are:

$$A = \frac{P(g + d - fa)}{h + g} \dots\dots\dots (56)$$

$$B = \frac{P(h - d + fa)}{h + g} \dots\dots\dots (57)$$

The values for the total pressure at the top and bottom of the

brake shoe respectively will be found to be as follows:

$$A_t = \frac{P}{h+g} \left( g+d-fa + \frac{fbg}{c} \right) \dots\dots\dots(58)$$

$$B_t = \frac{P}{h+g} \left( h-d+fa + \frac{fbh}{c} \right) \dots\dots\dots(59)$$

Referring to Fig. 5 *M*, it will be seen that the direction of action of *P* is opposite to that shown in Fig. 5 *K*. In this case the brake shoe pressure values are:

$$A = \frac{P(g+fa-d)}{h+g} \dots\dots\dots(60)$$

$$B = \frac{P(h+d-fa)}{h+g} \dots\dots\dots(61)$$

$$A_t = \frac{fPbg}{c(h+g)} \dots\dots\dots(62)$$

$$B_t = \frac{fPbh}{c(h+g)} \dots\dots\dots(63)$$

$$A_t = \frac{P}{h+g} \left( g-d+fa - \frac{fbg}{c} \right) \dots\dots\dots(64)$$

$$B_t = \frac{P}{h+g} \left( h+d-fa - \frac{fbh}{c} \right) \dots\dots\dots(65)$$

In Fig. 5 *N* the values of *A<sub>t</sub>* and *B<sub>t</sub>* will be identical with those given for Fig. 5 *M*, while the others will be:

$$A = \frac{P(g+d+fa)}{h+g} \dots\dots\dots(66)$$

$$B = \frac{P(h-d-fa)}{h+g} \dots\dots\dots(67)$$

$$A_t = \frac{P}{h+g} \left( g+d+fa - \frac{fbg}{c} \right) \dots\dots\dots(68)$$

$$B_t = \frac{P}{h+g} \left( h-d-fa - \frac{fbh}{c} \right) \dots\dots\dots(69)$$

These formulae assume that the reactions *A<sub>t</sub>* and *B<sub>t</sub>* are at points near the top and bottom ends of the shoe and results derived by this method will serve as a basis for conclusions as to the relative merits of the various methods of brake shoe suspension. Replacing the various symbols in the formulae by values in pounds and inches taken from examples in actual service, we may determine what is the effect of differences in suspension. Let

- a = 4.5 in.
- b = 7 in.
- c = 20 in.
- d = 4 in.
- P = 15,000 lb.
- f = .19 mean coefficient of friction (friction of motion). (R. A. Parke; see Railroad Gazette, June 14 and 21, 1901.)
- g = 10 in. } Cases K and M
- h = 2 in. }
- g = 2 in. } Cases L and N
- h = 10 in. }

CASE K, FORMULAE (54) AND (55).

$$A_t = \frac{15,000}{10+2} \left( 10-4-.19 \times 4.5 + \frac{.19 \times 10 \times 7}{20} \right) = 7,263 \text{ lb.}$$

$$B_t = \frac{15,000}{10+2} \left( 2+4+.19 \times 4.5 + \frac{.19 \times 7 \times 2}{20} \right) = 8,735 \text{ lb.}$$

Difference = 1,475 lb.

CASE M, FORMULAE (64) AND (65).

$$A_t = \frac{15,000}{10+2} \left( 10-4+.19 \times 4.5 - \frac{.19 \times 7 \times 10}{20} \right) = 7,775 \text{ lb.}$$

$$B_t = \frac{15,000}{10+2} \left( 2+4-.19 \times 4.5 - \frac{.19 \times 7 \times 2}{20} \right) = 6,265 \text{ lb.}$$

Difference = 1,510 lb.

CASE L, FORMULAE (58) AND (59).

$$A_t = \frac{15,000}{10+2} \left( 2+4-.19 \times 4.5 + \frac{.19 \times 7 \times 2}{20} \right) = 6,600 \text{ lb.}$$

$$B_t = \frac{15,000}{10+2} \left( 10-4+.19 \times 4.5 + \frac{.19 \times 7 \times 10}{20} \right) = 9,400 \text{ lb.}$$

Difference = 2,800 lb.

CASE N, FORMULAE (68) AND (69).

$$A_t = \frac{15,000}{10+2} \left( 2+4+.19 \times 4.5 - \frac{.19 \times 7 \times 2}{20} \right) = 8,470 \text{ lb.}$$

$$B_t = \frac{15,000}{10+2} \left( 10-4-.19 \times 4.5 - \frac{.19 \times 7 \times 10}{20} \right) = 5,600 \text{ lb.}$$

Difference = 2,840 lb.

It is evident that the suspension as shown at *K-M* is to be preferred over that shown at *L-N* as a more uniform dis-

tribution of pressure over the face of the brake shoe is thereby obtained.

One more common method of brake shoe hanging may be considered. This is the suspension of brake head about a point on the center line. Under this condition *h* = *g* = 6

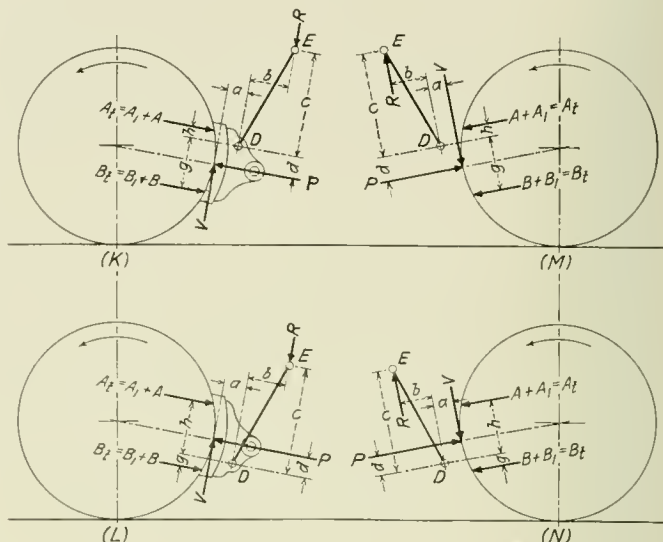

Fig. 5

in., and *d* = 0. The length and angularity of the hanger will be assumed as remaining unchanged. Referring to either formulae (54) and (55) or (58) and (59) for the leading wheel and substituting numerical values:

$$A_t = \frac{15,000}{6+6} \left( 6-.19 \times 4.5 + \frac{.19 \times 7 \times 6}{20} \right) = 6,930 \text{ lb.}$$

$$B_t = \frac{15,000}{6+6} \left( 6+.19 \times 4.5 + \frac{.19 \times 7 \times 6}{20} \right) = 9,068 \text{ lb.}$$

In a similar manner, by using either formulae (64) and (65) or (68) and (69) the values for the rear wheel are found to be:

$$A_t = \frac{15,000}{6+6} \left( 6+.19 \times 4.5 - \frac{.19 \times 7 \times 6}{20} \right) = 8,070 \text{ lb.}$$

$$B_t = \frac{15,000}{6+6} \left( 6-.19 \times 4.5 - \frac{.19 \times 7 \times 6}{20} \right) = 5,930 \text{ lb.}$$

The large differences in load between the two ends of the shoes make this method of brake shoe suspension undesirable.

The ideal suspension is one in which *A<sub>t</sub>* and *B<sub>t</sub>* are equal for the leading pair of wheels. Equating formulae (54) and (55) for the leading wheels:

$$\frac{P}{h+g} \left( g-d-fa + \frac{fbg}{c} \right) = \frac{P}{h+g} \left( h+d+fa + \frac{fbh}{c} \right)$$

$$d = (g-h) \left( \frac{fb}{2c} + .5 \right) - fa$$

The values of *g* and *h* depend upon the value of *d*. By referring to Fig. 5 *K* it will be seen that the relation is expressed by the equation

$$g-h = 2d \dots\dots\dots(56)$$

By substituting this value for *g-h* in the above and reducing it is found that

$$d = \frac{ac}{b} \dots\dots\dots(57)$$

and on substitution of the numerical values it is found that *d* = 12.9 in. This is beyond the limit to which the point of suspension can be raised above the center line of the brake head with the assumed dimensions and angle of inclination of the brake hanger, but it clearly indicates the desirability of raising the suspension as high as possible, and by proper proportioning of the length and angle of the hangers it would become possible to make the pressure equal at the top and bottom of the shoe.

Only so much of the subject of brakes has been treated



in this article as the writer thought was new. Other information bearing some relation to this is already available.

## COMPARISON OF ALL STEEL AND COMPOSITE COACH CONSTRUCTION\*

BY K. F. NYSTROM

Chief Draftsman, Car Department, Grand Trunk, Montreal, Que.

"Safety First" is the slogan of the present time. The safety of the working man and of the people at large, is at present considered as never before, and in passenger traffic this is carried to extremes. But the popular opinion regarding safety does not always coincide with the actual facts; for instance, an all-steel car can be of weaker construction than a wooden car. The all-steel car is considered by the traveling public as the only safe steam railway conveyance. Few practical men, however, will deny that the superstructure of a well-built wooden car is as strong as the average superstructure of a modern steel car. But they will admit that the weakness in an all-wood car lies in the underframe, on account of the continual increase in weight of trains.

### UNDERFRAME

The underframe, which is the back-bone of the car, must be of sufficient strength to sustain all imposed loads, including those arising from end-shocks. As the stresses produced from end-shocks in a heavy modern passenger train are occasionally extremely high, we have to resort to steel underframe construction. The ultimate strength of wood is too low to sustain the forces imposed. The wooden underframe is, therefore, a thing of the past in car construction.

In studying a number of designs of cars I have found that

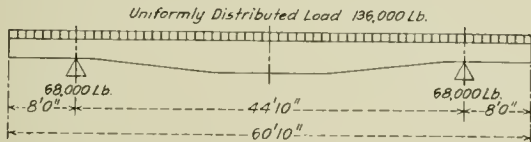

Estimated weight of car body.....	70,000 lb.
Live load.....	60,000 lb.
Overload, 10 per cent of live load.....	6,000 lb.

Total load.....	136,000 lb.
Bending moment = M.B.	
At center of car M.B. max.....	3,882,000 in. lb.
At bolster M.B. max.....	860,000 in. lb.

Fig. 1

in many cases it is economical to build the underframe sufficiently strong to carry the entire load, as well as to sustain the end-shocks. If the underframe is of sufficient strength to withstand both the load and the end-shocks the side construction can be much simplified. This is particularly true of mail and baggage cars, as the side posts can be uniformly spaced, thus reducing the amount of detail work.

In order to illustrate the requirements of a modern underframe the following example is selected: Figs. 1, 2 and 3 show an underframe for a 60-ft. baggage car, considered as a beam on two supports, these supports being the two trucks. The weight of the car has been assumed as 70,000 lb. for the car body and 60,000 lb. plus 10 per cent for live load, making a total of 136,000 lb. load on this underframe. This produces a bending moment of 5,882,000 in.-lb. at the center of the car and 860,000 in.-lb. at the bolster. The weight of car represented in this example is rather high and the live load is considerably above the actual requirements for a baggage or mail car. The United States post office department specification for a steel full postal car calls for a maximum of 50,000 lb. live load. The bending moment in a 74-ft. passenger coach is less than in the above example. It may, therefore, be assumed that if an underframe is designed to withstand

a bending moment of approximately 5,900,000 in.-lb. and an end-shock of 400,000 lb. it will be suitable for all classes of passenger cars.

The stresses imposed upon the underframe from end-shocks must be dealt with separately. The underframe must be treated as a column and both direct and eccentric forces considered. For members in compression the stresses must be reduced in accordance with usual engineering practice. The American Railway Engineering Association has adopted an empirical formula for unit compression stress as follows:

$$16,000 - 70 \frac{L}{R}$$

This formula has been approved by the United States post office department which allows 20 per cent greater fibre stress than that arrived at by using the above formula.

These requirements for the underframe could easily be satisfied if the car designer could change the construction to suit the conditions, but unfortunately a number of standards are established which the designer cannot change, such as truck height, coupler and buffer heights and the general clearance dimensions of cars. The designer has to compro-

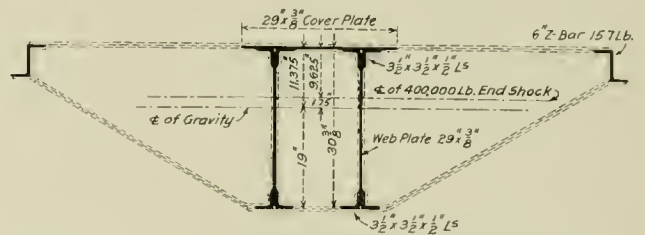

Area of section = A.....	67.805 sq. in.
Distance from top of cover plate to center line of gravity = e <sub>c</sub> .....	11.375 in.
Distance from bottom of center sill to center line of gravity = e <sub>t</sub> .....	19.00 in.
Center line of 400,000 lb. concentrated end shock = y.....	9.625 in.
Moment of inertia = I.....	9,428 in. <sup>4</sup>

Section modulus for compression =  $Z_c = \frac{I}{e_c} = \frac{9,428}{11.375} \dots\dots 829 \text{ in.}^3$

Section modulus for tension =  $Z_t = \frac{I}{e_t} = \frac{9,428}{19} \dots\dots 496 \text{ in.}^3$

Radius of gyration =  $R = \sqrt{\frac{I}{A}} = \sqrt{\frac{9,428}{67.805}} \dots\dots 11.8 \text{ in.}$

Allowable fibre stress per sq. in. for 60 ft. baggage car  
 $= \left(16,000 - 70 \frac{L}{R}\right) + \left(16,000 - 70 \frac{L}{R}\right) \frac{1}{5} \dots\dots 14,076 \text{ lb.}$

Bending moment produced by load (see Fig. 1) = Mb <sub>1</sub> .....	5,882,000 in. lb.
Bending moment produced by end shock = Mb <sub>2</sub> =	
400,000 lb. × 1.75.....	700,000 in. lb.
Total Mb.....	6,582,000 in. lb.

Maximum tension at center of car =  $S_t = \frac{Mb_1}{Z_t} = \frac{5,882,000}{496} \dots\dots 11,860 \text{ lb.}$

Maximum compression at center of car =  $S_c$   
 $= \frac{Mb_1 + Mb_2}{Z_c} + \frac{400,000}{A} \dots\dots 13,840 \text{ lb.}$

Fig. 2—Section Through Underframe at the Center

mise and be satisfied with a design which as closely as possible comes up to an ideal construction when considered from an engineering standpoint.

The sections shown in Figs. 2 and 3 satisfy the requirements for a modern underframe in relation to load and end-shocks. It will be observed that the extreme fibre stresses come well below the limits required by the United States post office department specification for all steel full mail cars, which is used as a foundation for all passenger car designs today.

The underframe considered in this example is probably not the most economical construction for all designs, but I have endeavored to give due attention to the construction from a maintenance standpoint, and have not employed any section with less thickness than 3/8 in. in order to provide ample bearing surface for all rivets and to give a reasonable allowance for deterioration. An attempt has been made to

\*Abstract of a paper read at the February, 1916, meeting of the Canadian Railway Club.

reduce the number of different sizes of material. All angles employed are of one size and all plates are  $\frac{3}{8}$  in. thick, so that the majority of details required can be obtained from the scrap cut from center sills.

The object, however, is not to produce an ideal design, but to show what a complex problem the car designer has to contend with.

BODY FRAMING

It is necessary to have a substantial end frame to prevent telescoping, particularly if an efficient anti-telescoping device is not employed. End framing built in accordance with United States post office department specifications, which call for a section modulus for vertical end members of not less than 65 of which 75 per cent must be concentrated in the door posts and posts adjacent to door posts, offers a very good construction which is amply strong.

To prove that the superstructure of a wooden car may be equally as strong as that of a steel car, I will compare the side posts in wood and steel cars. Fig. 4 shows a standard section of a wood post and Fig. 5, a typical design of a post for steel cars. For comparison consider the ultimate strength of ash to be 12,000 lb. per sq. in. and of steel 60,000 lb. per sq. in.; in other words, the steel to be five times as strong as ash when subject to bending. The United States post office department specification for the construction of steel full postal cars requires that "the sum of the section moduli taken

meet the United States mail service requirements. This comparison shows that the strength of the side of a wooden car—when considered perpendicular to its side, which is vital in case of wreck—is in some instances stronger than a steel car. I wish, however, to make plain that no claim of superiority is made for the side-framing of a wooden car, considered as a carrying member or truss. A combination of wood and steel for side-framing seems to me to be the most practical.

ROOF

No one familiar with car construction and maintenance of cars will deny that the canvas roof, properly laid, gives remarkably good service; in fact, it will outlast the car if given

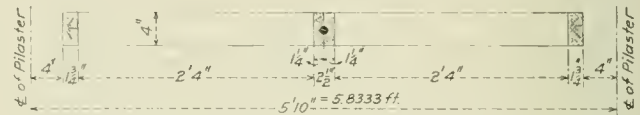

Section modulus four for ash posts as shown.....	16 in. <sup>3</sup>
Section modulus per running foot = $\frac{16}{5.8333}$ .....	2.74 in. <sup>3</sup>
The equivalent section modulus for steel, considering the strength of ash $\frac{1}{5}$ that of steel = $\frac{2.74}{5}$ .....	0.55 in. <sup>3</sup>

Fig. 4

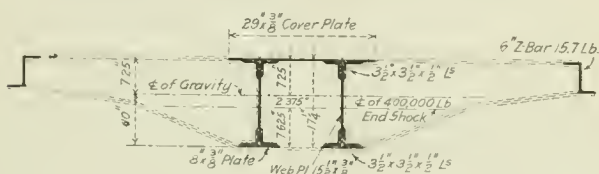

Area of section = A.....	63.68 sq. in.
Distance from top of cover plate to center line of gravity = $e_c$ .....	7.25 in.
Distance from bottom of center sill to center line of gravity = $e_t$ .....	10.00 in.
Center line of 400,000 lb. end shock = $y$ .....	19.625 in.
Moment of inertia = I.....	3,013 in. <sup>4</sup>

Section modulus for compression =  $Z_c = \frac{I}{e_c} = \frac{3,013}{10} = 301.3$  in.<sup>3</sup>

Section modulus for tension =  $Z_t = \frac{I}{e_t} = \frac{3,013}{7.25} = 416$  in.<sup>3</sup>

Allowable fibre stress per sq. in. for 60 ft. baggage car at bolster.....	15,000 lb.
Pending moment produced by load (see Fig. 1) = $M_{b1}$ .....	860,000 in. lb.
Bending moment produced by end shock = 400,000 lb. $\times$ 2.375 = $M_{b2}$ .....	950,000 in. lb.
Total $M_b$ .....	1,810,000 in. lb.

Maximum tension at bolster =  $S_t = \frac{M_{b1}}{Z_t} = \frac{860,000}{416} = 2,070$  lb.

Maximum compression at bolster =  $S_c = \frac{M_{b1} + M_{b2}}{Z_c} = \frac{400,000}{63.68} = 123.00$  lb.

Fig. 3—Section Through Underframe at the Bolster

at any horizontal section between floor line and top line of windows, of all posts and braces on each side of the car, located between end posts, shall not be less than 0.30 multiplied by the distance in feet between the center of end panels, a panel length being considered as the distance between lines of rivets in adjacent vertical posts."

In other words, the average section moduli on each side of the car for side posts must not be less than 0.30 per running foot. Now consider one section of the side of a standard railway car, now being largely used, the section being from center to center of pilasters which includes lower windows with a gothic above. The length of such a section is, on an average, 5 ft. 10 in. or 5.8333 ft. The number of posts in the 5.8333-ft. section is four for wood cars, two narrow and two wide, and three for steel cars. Referring to Figs. 4 and 5 the comparative section modulus for steel is seen to be 0.5 and for wood 0.55. The wood posts are 10 per cent stronger than the steel posts. Both constructions, however,

reasonable care. The steel roof, on the other hand, has not, up to the present time, proved a success. Steel roofs having vertical expansion joints about  $1\frac{1}{4}$  in. in height soon wear out on account of the abrasive action of cinders. The deck screens in an all steel car are objectionable on account of the pockets formed behind the screen in which gases, moisture and cinders collect. These destroy the paint and in a short time serious corrosion takes place, which cannot be detected before a car is sent to the shops for general repairs. A steel car roof must be frequently painted, and it cannot be neglected without serious consequences, as can a canvas roof, if the regular period between shoppings for any reason is prolonged. In connection with the canvas roof it is understood that the wood roof framing is tied together at frequent intervals with steel carlines which should extend in one piece from side plate to side plate, to which they should be firmly secured.

The inside finish in an all-steel car is hard to restore to its

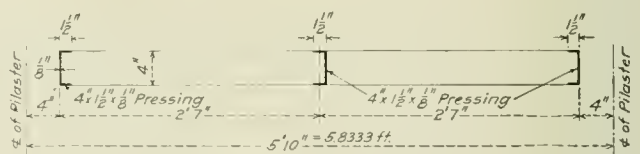

Section modulus of three pressed steel posts = $3 \times .98$ .....	2.94 in. <sup>3</sup>
Section modulus per running foot = $\frac{2.94}{5.833}$ .....	0.5 in. <sup>3</sup>

Fig. 5

original appearance, in case it must be touched up where the paint has been scratched, worn or peeled off. Wood cars having stained and polished wood finish can easily be restored to their original appearance in case the finish should be damaged.

The features of passenger car construction which, I believe, best meet present requirements, considering first cost, maintenance and the safety and comfort of passengers, may be summed up as follows:

First.—A steel underframe which will take care of all loads, strains and buffing shocks imposed on the car, with an efficient buffer, draft gear and some device which will lock the trucks to the body of the car in case of accident to prevent telescoping or a turn-over of the car.

*Second.*—A substantial end frame which will stand a very severe buffing shock and prevent telescoping.

*Third.*—A combination steel and wood side framing and wood exterior finish.

*Fourth.*—A combination wood and steel roof covered with canvas.

*Fifth.*—An interior wood finish.

With this construction the railroad can repair its own cars in the old wood-car repair shops, without going to the expense of installing a considerable amount of modern machinery, which would be necessary with all-steel cars. The traveling public will be provided with a car which will compare favorably in strength with an all-steel car. The inside finish can be made more artistic, easier to maintain and simpler to renew when required. In case of wreck the passengers will have a chance to cut their way out from the debris, which is impossible in an all-steel car.

The use of steam from the locomotive for heating passenger cars and lighting by electricity practically eliminate the danger of fire. The all-steel car is probably more nearly fire-proof, but when we consider that upholstering material, varnish and other details are inflammable, this car is comparatively as fire-proof as an all-steel car. The temperature in this car will not be subject to the sudden changes met with in the all-steel car. It will be warmer in winter and cooler in summer, and will not develop the sweating which is so troublesome in all-steel cars.

## STEEL BOX CARS ON THE PENNSYLVANIA

"Another Step Toward Making This an All-Steel Railroad," is the title of an article which appeared in a recent number of the Pennsylvania Railroad bulletin, "Information." This little publication is intended for the use of both

the extent to which the manufacture of all-steel box cars is carried on by the Pennsylvania and also the statement of policy which it contains as to the use of steel equipment by that system. The article is as follows:

Not many years will pass before the wooden box car will be a thing of the past on this railroad system. The fact is, it will not be long before every train operated by this railroad will be all-steel from one end to the other. One year ago the Pennsylvania Railroad announced that it had added to its equipment the most modern type of freight car in the world—the all-steel box car. To-day it has in operation more than 2,000 of these cars which have replaced wooden ones. Others are being turned out by the railroad shops at Altoona, Pa., at the rate of one every 55 minutes. At the end of 1915 the company had 6,500 steel box cars, representing an investment of about \$9,000,000.

The first steel box car cost \$1,500 to build. Experience has reduced this cost materially; it is now about \$1,300, which is still considerably above the cost of a wooden car, but this railroad believes that steel box cars will, to a large extent, justify their higher first cost by their added durability, greater strength and longer life.

Employees to the number of 705 are engaged in building these steel box cars in the Altoona, Pa., shops.

### WHERE THE STEEL BOX CARS ARE BUILT

The building in which the steel box cars are constructed—the company's Altoona steel car shop—covers the space of a large city square and looks as though it had been built to be the mammoth of all convention halls. The visitor's first impression is that he has entered a boiler factory. This is because every car is put together with 5,100 rivets, and every rivet is driven home with a rattle of blows from a pneumatic riveting tool—unquestionably one of the most successful noise-making devices ever invented.

Someone with a taste for figures has calculated that on a



Part of a Day's Output of Steel Cars from the Pennsylvania Steel Car Shop, at Altoona

the employees and the public. While the article is of the semi-popular type, as contrasted with the strictly technical article, it will undoubtedly prove of interest to many of our readers because of the information which it presents covering

busy day the riveting tools in this building strike 1,000,000 impacts upon resounding steel, or 25 to 30 per second throughout the working hours.

A steel box car from the trucks up—that is, the under-

frame, body and roof—is built practically altogether of riveted steel plates. These plates are first moved by overhead cranes to the shearing machines, of which there are several of different sizes. Suspended in chains, so that they may be swung and turned with the least possible expenditure of human effort, the plates are seized by gangs of men who, combining skill with brawn, guide them between the blades of the shears, where they are cut into the proper shapes. The largest of the shears can make a 10-ft. cut in a quarter-inch steel plate about as easily as a tailor snips three inches from a piece of cloth.

Next the rivet holes are punched. On the longest pieces this is done on the "multiple punch," a wonderful machine which handles four pieces of work at once, and can make as many as 160 holes through a half-inch steel plate on every movement.

After the punching, if the plates are not intended for parts of the car which are perfectly flat—that is, if the edges are to be turned for riveting, or if they are to be bent into the "U" forms used in giving rigidity to the underframe—they next go to the forming presses. These are the most powerful machines in the Altoona shops. The largest of them is capable of exerting nearly 4,000,000 pounds pressure. It folds steel so noiselessly and easily that it is difficult to realize the enormous power that is applied.

Fitting the center sills is the first job in erecting a car. A gang of men, armed with pneumatic riveting tools, fasten the sills together as fast as red-hot rivets can be tossed to them

small erecting trucks and lowered on a set of regular trucks, which are placed on a standard gage track leading out into the yards.

The roof is next added. The last operation inside the shop is riveting on the side ladders and hand-holds and applying the hand-brake equipment. The car is pushed out into the yard, where it is cleaned with benzine to remove grease. It is then ready for painting.

A steel box car in the course of construction occupies eight positions on the erecting tracks and goes through twenty-seven classified operations, each of which, of course, embraces the doing of a multitude of things. The 5,100 rivets which are beaten into place with the pneumatic tools hold together 129 pressed steel parts in each car. The car, with its trucks and equipment complete, weighs 50,000 pounds, and has a carrying capacity of double that.

In building steel box cars this company is following its policy of making steel the standard form of construction for all its cars. The Pennsylvania Railroad was the first to adopt steel passenger cars, and now owns more than any other railroad in the world.

### SERVICE OF NORFOLK & WESTERN 90-TON CARS

The Norfolk & Western has had in use for over two years 750 of the 90-ton capacity gondola cars which were described in the *American Engineer* for January, 1913, page

COMPARATIVE DATA ON NORFOLK & WESTERN COAL CARS

Car.	Light weight.	Pounds of coal in heaped car at 58.85 lb. per cu. ft.	Gross weight.	Volume in cu. ft.			Pounds lt. wt. of car per cu. ft. of heaped capacity.	Ratio of revenue load to total load, based on heaped coal load at 58.85 lb. per cu. ft.	Number of cars in a 5,000-ton train, cabin car not included.	Tons of coal in a 5,000-ton train, cabin car not included.	Coupled length of car.	Length of a 5,000-ton train, cabin car not included.
				Level.	30 deg. heap.	Total.						
57½-ton all steel hopper, Class HP. Two 4-wheel trucks.	42,900	125,400	167,400	1,807	327	2,134	19.7	75.0	59.7	3,743.19	33 ft. 5½ in.	2,000 ft.
57½-ton all steel gondola, Class GJ. Two 4-wheel trucks.	43,500	116,200	159,700	1,547	429	1,976	22	72.8	62.2	3,637.06	41 ft. 10¼ in.	2,620 ft.
90-ton all steel gondola, Class GKa. Two 6-wheel trucks.	59,300	198,900	258,000	2,829	551	3,380	17.5	76.9	38.7	3,850	48 ft. 9 in.	1,887 ft.

from the forges. Next in order, after the joining of the center sills, is the fitting and riveting of the diaphragms and braces, the application of air-brake equipment and couplers, and riveting the sides and ends. The car is then lifted from the

35. and 1,000 more are now on order. The accompanying table gives some interesting figures for these cars in comparison with 57½-ton cars also used on this road in coal service:

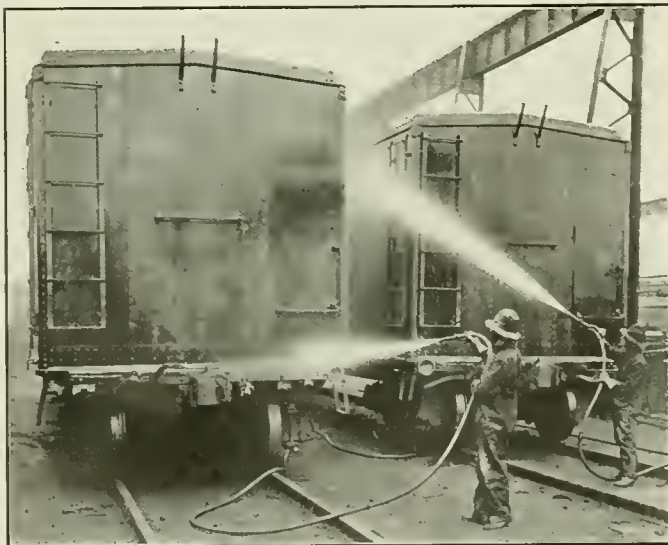

Painting Pennsylvania All-Steel Box Cars

**UNDERFEED STOKERS AND COMBUSTION.**—An underfeed stoker is able to smokelessly burn even high-volatile coals, because when the volatile is distilled, it must pass through the hottest part of the fuel bed before getting out into the furnace. Besides a sufficiently high temperature, the only other chief requirement for the proper burning of the volatile is time, just as it takes time for a cake of ice to melt at summer heat.—*Power.*

**FRENCH FUEL BINDER.**—A fuel binder recently patented by a French maker, which is fusible to a vitreous mass at 200 deg. C., consists of 15 parts of glassmaker's sand, 18 parts of Portland cement, and 10 parts of carbonate of soda or other flux for silica, such as sea salt or sulphate of soda. Dry fuel dust, such as coal in grains up to 5 mm. in size, is mixed with from 4 to 6 per cent of the mixed binding ingredients, the product, with the addition of 8 per cent of water, being compounded in a mixer to which steam under 8 kilos. pressure, at 170 deg. C., is admitted, the mass subsequently being pressed into briquettes. Heat may be applied to the material issuing from the press to increase the cohesion.—*Engineer.*

# SHOP PRACTICE

## BRAKE BEAM STRAIGHTENING PRESS

BY E. F. LICKY

One of the difficult and laborious jobs in a car repair shop is the repairing of the various types of brake beams which come in for straightening and the renewal of parts. The most difficult tasks are the stripping of the beam, which is done largely by manual labor, and the straightening of the beam after being stripped. The beam is usually straightened on a face plate with a sledge hammer and flatter after it has been brought to a red heat in an oil furnace. This operation is made difficult by the thin flanges and webs of the various members and because of the variety of twists and kinks encountered.

The best plan for performing this work is to concentrate

was made up mostly of material or patterns for parts already at hand. Patterns were already available for the large face plate forming the base and for the cylinders and cylinder heads so that the only ones which were required new were those for the dies and columns. The cylinders used were 10-in. waterscoop operating cylinders. The press was piped up as shown in order to get a uniform flow of air to the two

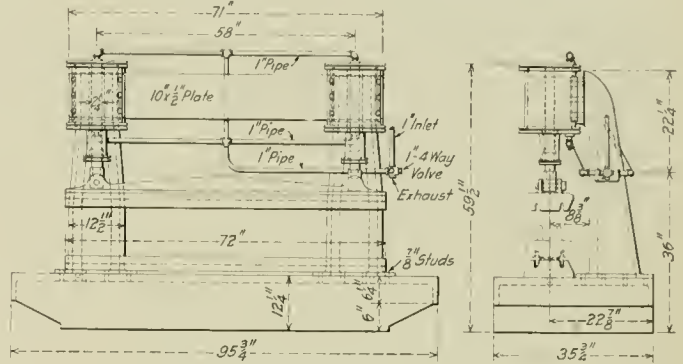

Press for Straightening Brake Beams

cylinders and to prevent as far as possible any binding due to one piston coming down ahead of the other.

In handling the beams it is usually customary to group the various types of beams together. They are then stripped and the dies for the particular kind to be handled applied to the straightening machine. The beams are heated in an oil furnace large enough to take the entire beam and when brought to a red heat they are withdrawn by suitable tongs or hooks and taken to the straightening press. Small kinks in the flanges of I-beams are first hammered out and the

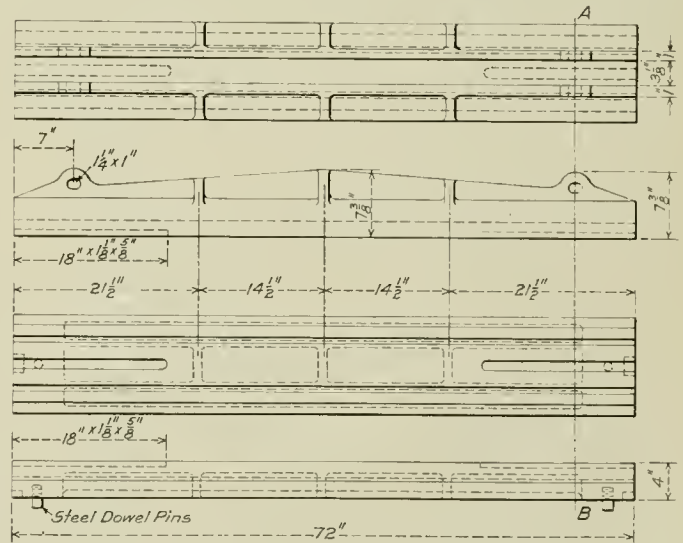

Dies for Brake Beam Straightening Press

beam is then inserted in the dies. Sometimes more than one operation is necessary to straighten a badly twisted beam, but a much better job is done than with the old method of straightening with sledge and flatter. It is unnecessary to change dies for each type of beam as it is possible to use the I-beam dies for a number of bulb beams. This is an advantage as the dies are heavy and difficult to handle.

The use of a 12-in. or 14-in. cylinder in place of the

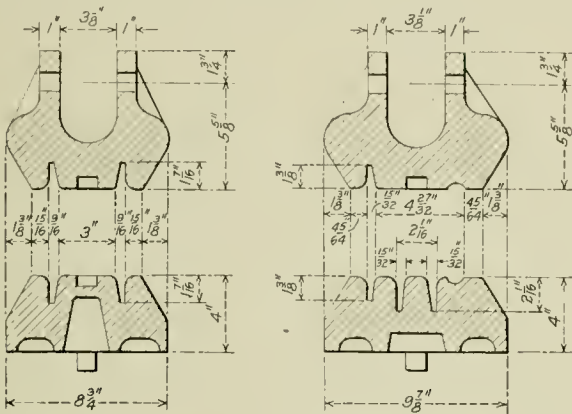

Sections of Some of the Dies Used

it for an entire road at one shop where tools and facilities can be maintained for doing the work to the best advantage. Brake beam work for the New York Central west of Buffalo is taken care of at the Air Line Junction car shops (Toledo, Ohio), the brake beams being shipped in to this point, repaired and returned to the other car repair points. In order to get away from the laborious hand method it was thought desirable to provide some kind of a press for straightening the beams, the development of which was assigned to the writer. The problem of designing a press which would do the work desired was rather difficult on account of the great variety of sections to be handled, but a pneumatic press having two cylinders mounted as shown in the drawing, was finally decided upon.

In order to keep the cost as low as possible the machine

10-in. cylinder shown would probably be of considerable advantage. The additional pressure secured would be desirable when more than one operation is required as the beam often cools slightly between operations. The machine is operated on 80 lb. to 100 lb. air pressure.

Details of some of the dies which are being used are shown and it will be noted in some cases that they are made to take two different styles of beams, thus reducing the number of dies required. The press has been in operation for several months and has proved very satisfactory.

### PATCHING BOILERS

Since the inauguration of the Federal boiler law, locomotive boilers are being patched, when this becomes necessary, in a variety of ways, some of which are good, while others reflect but little credit on those who do the work. One or two roads are carrying out this work entirely through the drawing office, a sketch being furnished the mechanical engineer by the shop officers. The drawing office then determines the best method of patching and

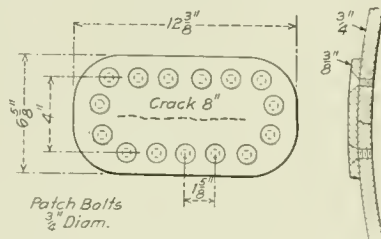

Fig. 1—A Bad Example of Boiler Patching

issues a blueprint. One large road in particular is having conspicuous success with this practice.

Returning to the discussion of patches in general, Fig. 1 represents a patch applied by shop forces without first receiving proper instructions from the drawing office. It will be noted that the patch is applied with patch bolts instead of rivets, and that the patch material is only 3/8 in. thick instead of the thickness of the shell sheet. The efficiency of the single riveted seam in this patch is very low

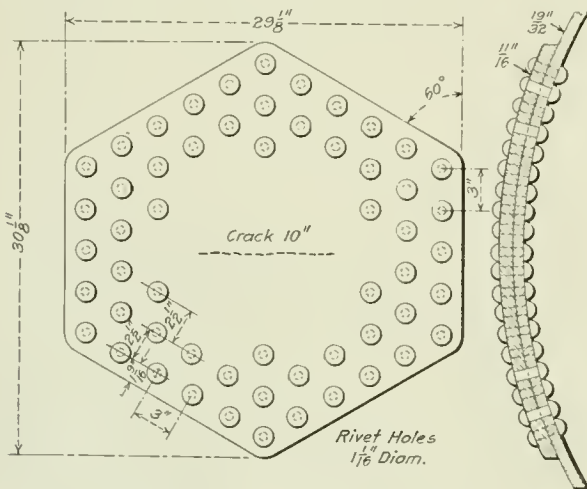

Fig. 2—Another Unsatisfactory Patch

and the factor of safety of the boiler has been materially reduced. The efficiency of the longitudinal seams in the shell of this boiler is 84 per cent. It is needless to say that such patches are very unsatisfactory.

Fig. 2 shows a patch applied in accordance with general instructions from the drawing office. These general instructions cover all patches and the patches are applied by the shop before the drawing office is advised of the defect.

In this case it would appear that the drawing office did not calculate the efficiency of the patch before the general instructions were issued. This patch is unsatisfactory and it will be necessary that it be removed or the boiler pressure reduced. The efficiency along the outer row of rivets can be found by calculating the seam as a diagonal seam. Many railway men would probably criticize this patch because of its unusual size and the large number of rivets used. It is, of course, possible to apply a smaller patch with fewer rivets at less expense, which would be materially stronger.

Fig. 3 illustrates a patch which was applied after proper

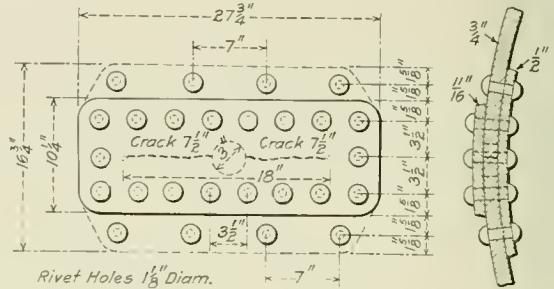

Fig. 3—A Patch Which Maintains the Factor of Safety

instructions were issued to the shop by the drawing office. In general these instructions are that in applying a patch the seam used should be as nearly as possible a duplicate of the longitudinal seam in the shell of the boiler. The pitch of rivets in the outer row of the seam is the same as the pitch of rivets in the outer row of the longitudinal seam. Comparing the patch shown in Fig. 3 with that in Fig. 2, it will be noted that it requires less material and fewer rivets and, of course, less time and money to apply the patch shown in Fig. 3. It will also be noted that although the patch in Fig. 3 is smaller than that in Fig. 2, the crack shown in Fig. 3 is nearly twice as long as the one shown

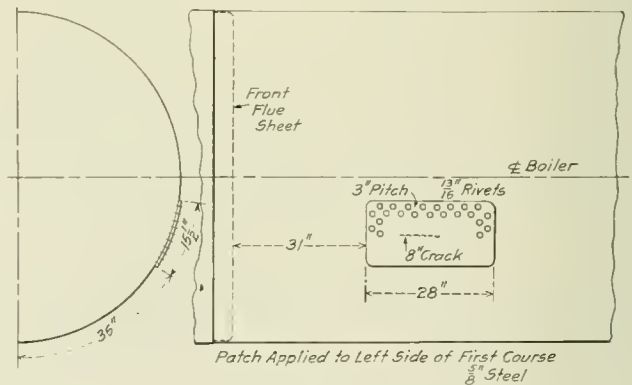
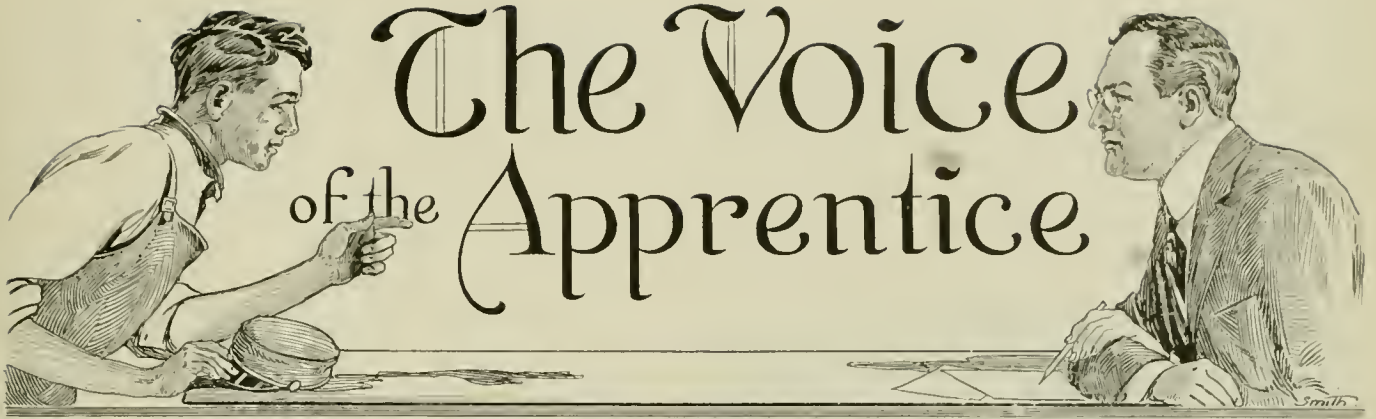

Fig. 4—This Patch Reduced the Factor of Safety to Less than Three

in Fig. 2. The factor of safety of the boiler was not reduced by applying the patch shown in Fig. 3.

The patch shown in Fig. 4 was applied to repair an 8 in. crack. It should be noted that a double-riveted lap joint is used for this patch, the efficiency of the seam being 70.8 per cent. The longitudinal seam on this course is a diamond seam with a calculated efficiency of about 96 per cent. The patch reduced the factor of safety of the boiler from over four to less than three.

**PROTECTION OF BLOWOFF PIPES.**—The blow off of a stationary boiler should be opened frequently enough to keep the pipe clear, and a bottom blowoff pipe that would be exposed to direct furnace heat should be protected by firebrick, a substantial cast-iron removable sleeve or a covering of non-conducting material.—*Power.*



Many railroads have made special efforts in recent years to attract young men to enter the shops and train them to become intelligent, efficient mechanics. What does the apprentice think of these methods and the treatment accorded him, and how in his opinion can they be improved with a view to securing better results? To obtain an expression from the apprentices a competition was announced in our issues of January and February.

As noted in the editorial columns, the first prize was awarded to J. C. Bowman, an apprentice at the Avis shops of the New York Central, and the second prize to E. C. Crawford, a machinist apprentice at the Drifton, Pa., shops of the Lehigh Valley Coal Company. Twenty-seven contributions were received from apprentices of the Lehigh Valley Coal Company and ten from apprentices on different railroads. The railroad contributors were M. R. Brockman, apprentice at the Spencer (N. C.) shops of the Southern Railway; William Heise, third year machinist apprentice, Erie Railroad, Jersey City, N. J.; William Johnston, fifth year locomotive apprentice, Canadian Pacific, Montreal, Que.; A. T. Kuelmer, assistant road foreman of engines, Baltimore & Ohio, Newark, Ohio (apprenticeship completed February 15, 1915); William L. Lentz, machinist apprentice, New York Central, Avis, Pa.; Arthur J. Merriman, boilermaker apprentice, Atchison, Topeka & Santa Fe, Richmond, Cal.; Nielsen Pollard, fourth year apprentice, Atchison, Topeka & Santa Fe, Albuquerque, N. Mex.; Carl J. Pryor, fourth year apprentice, Atchison, Topeka & Santa Fe, Clovis, N. Mex.; T. S. Tulien, special apprentice, Atchison, Topeka & Santa Fe, Topeka, Kan.

The Lehigh Valley Coal Company apprentices at Drifton, Pa., who participated were James Bowen, Howard F. Brauch, Victor E. Brauch, Albert W. Breyfogel, Thomas D. Brobst, Frank Chicalace, Charles M. Crawford, Harry E. Davis, Tony De Grosse, Charles A. Giulia, Stanley Hontz, Frank M. Jenkins, James Kennedy, Elmer Klein, Emanuel Korn, Clayton Kresge, Harrie E. McClellan, Bernard Murrin, Louis J. Polanerzky, Clifford L. Sachs, Emery Shanno, Charles Sweeney, Jr., Henry Thomas, Paul Tucker, Percy Turnback and Wilbert P. Wehner.

The two prize articles, with others, appear in this issue. A large number of the other contributions are well worth publishing, either in whole or in part, and will appear in future issues.

#### FIRST PRIZE ARTICLE

BY J. C. BOWMAN

Apprentice, New York Central, Avis Shops, Jersey Shore, Pa.

The larger railroads have organized apprentice systems and have provided class-rooms, in which the apprentice is obliged to spend a certain number of hours each week. Here he is instructed in mechanical drawing, sketching, blue-print reading, the common school studies, and the theory of his trade. This program, in conjunction with his practical ex-

perience in the shop, should make of him, at the end of his apprenticeship, a highly efficient mechanic.

These railroads are offering to the young man who wishes a technical education, and who cannot afford to get it at some college, an opportunity to realize his ambition.

Concentrating his mind exclusively on his work, both in the class-room and in the shop, helps the apprentice more than anything that can be done for him by his class instructor or by his shop foreman. To inspire him to thus concentrate his mind and to work to the limit of his ability, he has the knowledge that when he finishes his apprentice period, or as soon afterwards as an opportunity occurs, he will be promoted to a position of trust.

The practice of placing the apprentices on their own responsibility seems to make the greatest appeal to the bulk of the apprentices in their course of training. This is done by giving an apprentice charge of a job, with an assistant. It shows that some trust is placed in him and influences him to work harder to be worthy of this trust. This method also teaches him to think for himself.

So, all in all, the apprentice of today is pretty well provided for, both during his apprenticeship and afterwards. However, there are improvements that could be made in the apprentice systems that would make them of more practical value to the apprentices. Enough school work is not required of the apprentices outside of school hours. If a young man wishes to learn he should be willing to do anything required of him by those who make it possible for him to realize his ambition. Then again it might be an incentive to closer application to work if the diploma, which the industrious apprentice receives, showed him to be a man of higher standing than the one received by the apprentice who merely drifted through his apprentice period.

#### SECOND PRIZE ARTICLE

BY E. C. CRAWFORD

Machinist Apprentice, Lehigh Valley Coal Company, Drifton, Pa.

Although an apprentice of only a few months' experience in the machine department of the Drifton shops, I have had evidence of the interest and co-operation which the management shows in its dealings with its employees. Its effort to keep working conditions the best possible, maintaining sanitary shops—clean, well-lighted, and ventilated—serves as an inducement for workers to try more conscientiously to serve their employers.

The endeavor to prove to us that they consider us more than mere cogs to grind out dollars for their industrial machine is doubly inspiring, as it shows they wish us to live, not merely exist.

From the apprentice's viewpoint, I firmly believe the following slight changes in attitude and management would prove beneficial to us:

- (1) A little more leniency in punishment for shortcomings.
- (2) Recommendations upon our entering a department,

as to the tools which shall be required, where to acquire them and what make has met with the management's approval and is the uniform standard for its master artisans.

(3) Monthly lectures by the heads of the various departments dealing exclusively with the work of their distinct division, for which lecture the student apprentice should receive some preliminary coaching as to the proper method of jotting down notes, so that he may note the vital points of the foreman intended to convey.

(4) Establishment of a small circulating library dealing exclusively with systematic methods of production and technical work.

(5) A method of systematic, rather than periodic advancement as the apprentice familiarizes himself with the work of a distinct department.

(6) Establishment of a system of awarding slight bonuses to those artisans excelling in rapidity of production, thus causing the awakening of a keen sense of rivalry (altogether friendly, however), thereby causing an efficiency as regards production, amounting to practically 100 per cent.

(7) A recommendation that all apprentices attend some local night school, not making it compulsory, but presenting such inducements to those who do attend that those negligent in such matters will see that it is to their interests to do so.

### SOME PRACTICAL SUGGESTIONS

BY M. R. BROCKMAN

Machinist Apprentice, Southern Railway, Spencer, N. C.

Two incidents that encouraged me very much were (1) the superintendent of motive power inquiring if I were making good and offering any advice that I might desire; (2) the master mechanic gave me leave of absence with transportation, so that I could attend a special short course at school, saying that my apprenticeship would not be lengthened to make up for my absence, because I tried to do my best.

These incidents showed that the officers were interested in my progress, so I worked harder that they would continue to be interested and willing to help me.

Several days ago I asked the shop superintendent if he would kindly hold open one of the machinist vacancies until my apprenticeship expired, in about two months. He said: "I will gladly do this, young man; I wish that your time was out now, so that I could put you at the regular machinist's work." This incident showed that my efforts were not in vain, so I set out to make the last two months of my apprenticeship the most successful of all.

The present apprentice courses with the shop drawing school are efficient, but I think can be improved. The apprentice school can be improved by having a practical man that will teach more about shop kinks than drafting. The ordinary machinist's pay is nearly twice that of a fairly competent draftsman. Why not teach the apprentice about the locomotive which he will have to work upon, instead of drafting, which is another trade.

Reading drawings is the chief benefit derived from the study of drafting by the apprentice. This serves its purpose, but is a slow method. Why not teach the reading of drawings more efficiently and use the hours formerly spent in practising lettering and crosshatching, etc., for instruction in the advantages of different types of valves and valve gears, angularity of main rods, equalization of springs, the theory of air brakes, safety appliances, etc.

Instruction such as the above would certainly interest the average young man, and at the completion of his apprenticeship he would be a capable railroad machinist. Knowledge of the theory of machinery frequently prevents bad judgment when repairs are to be made.

I find that the work is much more interesting and that I learn a great deal more when working with some expert mechanic than with a group of apprentices under one fore-

man. Each mechanic has different labor and time-saving methods which would not die when they do, if the apprentice were given an opportunity to learn them; and the apprentice would be better informed if this practice were more commonly followed.

### A SUGGESTION TO OFFICERS

BY A. T. KUEHNER

Assistant to Road Foreman of Engines, Baltimore & Ohio, Newark, Ohio

(Apprenticeship completed February 15, 1915)

My career as an apprentice with the Baltimore & Ohio was exceptionally interesting. I began in the erecting shop, spent a few months each in the machine shop, air brake department, car shops, roundhouse, and the last six months with the road foreman of engines, this covering a period of three years.

The methods employed by our road in handling apprentices, both in personal treatment and mechanical teaching, can, I dare say, hardly be improved upon. Each apprentice enters under a certain class, according to his schooling, and is scheduled to follow out special instructions covering that class. Our mechanical instructor, a thorough, practical man, fair and square to all, has charge of the apprentices and sees to it that all boys receive proper instructions, fair treatment and are made to follow out the schedule. Then we also have an apprentice school, where we are taught the rudiments of mechanical drawing. Each apprentice attends school twice a week, from seven to nine in the morning; to make this work more interesting the company at the end of the term gives the three best and most energetic workers prizes that are well worth striving for.

At the close of the apprentice school the boys usually give a banquet and invite the higher officers, and the invitations are always gladly accepted. At one of these banquets I received my greatest inspiration, sitting among these great men, and hearing their early and wonderful careers and how they advanced step by step—really the finest kind of advice and encouragement. One statement in particular, made by one of our mechanical officers, stating that he felt the apprentices of today were not qualifying themselves for official positions as they should, being proved by the fact that there were more positions open in the supervising capacity than there were in the journeyman class, but no material available to fill them with, appealed to me strongly.

Boys, right here was where I stopped thinking of the impossible, and the thought of just finishing out the day. Instead I worked with renewed energy, and not very long afterward saw results forthcoming. And today I am more proud than ever of having heard this statement and the effect it had upon me, as it has led me to a position where the greatest future can be obtained. Can't more meetings of such a kind be arranged for, where the apprentices may meet the higher officers, to let the apprentice know he is being thought of and to hear the words that were so inspiring to me?

### THE SANTA FE METHOD

BY T. S. TULIEN

Special Apprentice, Atchison, Topeka & Santa Fe, Topeka, Kan.

One of the great questions with which the present-day manufacturers have had to deal is that of obtaining workmen, not only skilled and efficient but familiar with their peculiar requirements and from whom they can develop and choose men for executive positions. This has been solved to a great extent by the apprenticeship system. It not only gives to the company good workmen but offers the opportunity to observe which men are fitted to serve as foremen, or in higher official capacities.

The benefits are not restricted, however, to the manufacturer alone, but offer advantages to the apprentice himself which could be derived in no other way. There are a great many young men who are capable of holding good positions.



but are held back by their own timidity. If these same young men were to learn a trade under the old apprenticeship system, they would have nothing more than just the bare mechanical practice at the end of their courses. If they were observed at all it was only with reference to the kind of work they were turning out. Under the present system these young men come into direct contact with men who realize their ability and with a little help on their part are able to push ahead. By this means the young man is given not only the chance of earning a good livelihood, but a good substantial foundation for building his career.

The Santa Fe, under the supervision of F. W. Thomas, has an especially good system. This course covers a period of four years, during which time the apprentice is put through the various operations comprising his trade. The apprentices are divided into groups, and each group is put under the supervision of an instructor. These groups are small enough to allow the instructor to give a great deal of personal attention to each boy.

Before entering the course the applicant is required to pass a mental as well as physical examination. Although the examination is simple it is of such a nature as to show clearly the boy's ability to advance. The applicant must be between the ages of 16 and 21.

Upon entering the shop the apprentice is given the more simple operations and is advanced step by step, the period of time for each depending on the nature of the work, until, at the end of 12,000 hours, he has passed through all the typical operations. Apprentices of 21 years or over are required to fire locomotives on trial trips. This gives them the opportunity of observing the methods of handling and firing locomotives and also of locating defective work.

Besides the work in the shop the apprentice receives four hours of schooling each week. In the schoolroom he is taught mathematics, drawing, writing, and things pertaining to the department in which he is working.

Apprentices in the fourth year are required to attend night school one evening each week for a number of the winter months. These night schools cover various phases of the work in which he is interested. A competent instructor is placed in charge of each class. At different periods during the course men well versed on the subject are invited to address the respective classes.

Another feature which is proving very satisfactory was added about a year ago. This is a special course open to special apprentices in their third year, or journeymen apprentices in their fourth year. Apprentices for this course are selected by the local mechanical department, upon approval of the mechanical or shop superintendent and supervisor of apprentices. This course gives the young man an opportunity of preparing himself for general railroad work. It consists of two months in the boiler shop, two months in the car shops, four in the roundhouse, two with the road foreman and two months inspecting locomotives. Besides this work a course of reading, prescribed by the supervisor of apprentices, must be pursued by the apprentice. At the end of each month he is required to write a letter to the master mechanic telling of the work in which he has been engaged and offering criticism and suggestions. Also, at the end of each division of the course, he must be able to answer a set of questions covering that work. This last feature is especially good, for it gives the apprentice a knowledge of the things upon which to lay most stress.

As a conclusion it might be said that the advantages to be gained by the apprentice cannot be estimated, for they depend to a great extent on the apprentice himself. He must be willing to take an interest in his work, work hard and study. For my part, I am just beginning to realize all the advantages that I have gained. Perhaps one of the greatest was the opportunity I had of obtaining the Ryerson Scholarship, enabling me to take a four-year course at Purdue University.

## A RECORD CYLINDER WELD

Ever since the oxy-acetylene welding process has been in general use in locomotive shops instances have been mentioned of the success with which locomotive cylinders have been welded by this process. To those who have had but little experience in this connection, a certain job done at the Kansas City shops of the St. Louis & San Francisco will appear remarkable.

From Fig. 1 it will be seen that the cylinder casting was



Fig. 1—Broken Locomotive Cylinder That Was Repaired by the Oxyweld Process

broken in two pieces. Fig. 2 shows these two pieces welded in place. The cylinder was placed in service without being bushed and with no reinforcement except for the ring on the end of the cylinder, which is now believed to have been unnecessary, and has been running for some time successfully. John Foster, master mechanic in charge of the shops at which this work was done, describes the work as follows:

"The two broken parts were V'd out and clamped together in a true circle and placed on a blacksmith's fire,

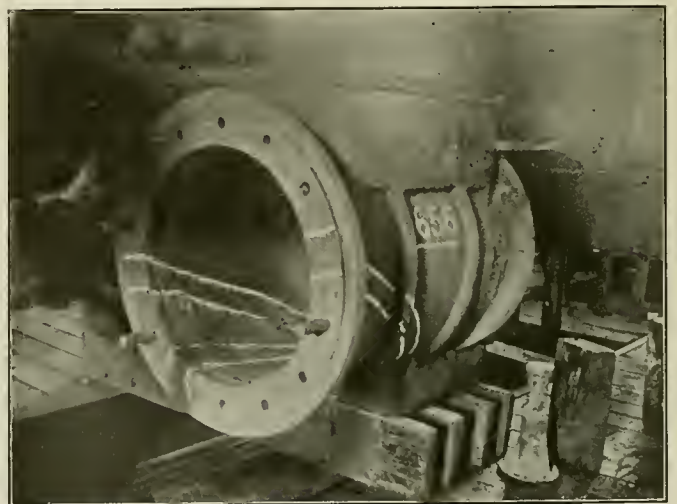

Fig. 2—The Welded Locomotive Cylinder

preheated and then welded together on the fire. This left one piece instead of two. This piece was then put up in the cylinder with what would be termed an arch clamp. This clamp was bent up in the shape of a U flattened out at each end and attached to the two studs in the cylinder next to the broken part, the idea being to give the operator

an opportunity to do the work without any of the surface of the clamp interfering. The cylinder was preheated to a good cherry red by a wood and charcoal fire and kept at an even temperature during the entire process of welding. Two operators were used, one from each end of the cylinder. The torches were extended, making them much longer in order to keep the operators as far away as possible from the intense heat. After the welding was completed the cylinder was thoroughly heated again by building a good charcoal fire inside and out, the fire being maintained until the entire work was uniformly heated. It took nearly 24 hours to bake the cylinder and allow it to cool off gradually. Below is an itemized statement of the cost of renewing the cylinder under the old method and the cost of welding by the Oxweld method:

OLD METHOD	
Cost of cylinder finished.....	\$230.00
Other material .....	19.28
Labor removing old and applying new cylinder.....	55.65
	\$304.93
Less value of scrap cylinder.....	31.70
	-----\$273.23
OXY-ACETYLENE METHOD	
Labor preparing .....	\$4.50
Wages of burner operators.....	7.20
Cost of Oxweld material.....	26.36
Labor finishing .....	19.00
	-----\$7.06
Total saving .....	\$216.17

The time required to do this job was as follows:  
 Preparing ..... 1 day      Grinding in the head..... 1 day  
 Welding ..... 1 day      Finishing ..... 1 day  
 Annealing ..... 1 day  
 Boring and finishing cylinder ..... 2 days      Total ..... 7 days

"The credit for this work is due C. R. Kew, general foreman, and Martin Whalen, foreman blacksmith, at these shops."

**HIGH SPEED STEEL TIPPED LATHE TOOLS**

BY E. J. McKERNAN  
 Supervisor of Tools, Atchison, Topeka & Santa Fe

In order to derive the greatest use from our available high speed steel we have tried in many ways to weld high speed steel tips on tire or carbon steel shanks, and have now accomplished results that are entirely satisfactory. We find that the oxy-acetylene process is best for doing this work. The method followed in making the weld is shown plainly in Fig. 2. The carbon steel holders must be forged as indicated in order to get the best results; also, it is necessary to forge the high speed steel tips to as nearly the proper dimensions as possible before the weld is made. When welding the tips should be heated to about 2,200 deg.

work is done in the blacksmith shop, but the welding is done by an expert gas welder. After the welding has been completed it is necessary for the tool grinder to grind the tools to the proper shapes.

On our wheel lathes we have been able to turn out 250 pairs of coach wheels with a pair of tools which were 2 in. by 3 in. by 20 in. These tools have given excellent service and we are able to keep up the same speed as when we used the solid high speed steel tools. Furthermore, we have had the tips "break down" on one of the welded tools, and have redressed them practically in the same manner as the solid high speed steel tools are redressed. This was done successfully without the high speed steel tip becoming loose

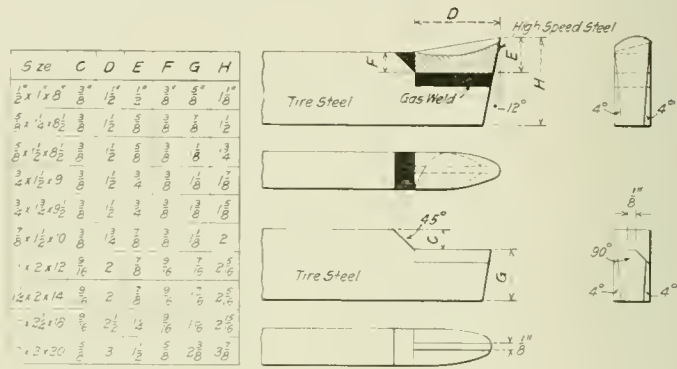

Fig. 2—Method of Welding High Speed Steel Tips to Carbon Steel Tool Shanks

on the carbon steel shank. To redress these tools successfully it has been found advantageous to draw the part of the tool underneath the tip down to about 1/4 in. below the bottom surface of the tool. It is then placed under a steam hammer and a blow is struck on the top surface directly back of the welded tip. This will return the point of the tool to the proper place, giving it the proper shape, etc. We have adopted this plan over the entire system and it is giving complete satisfaction so far. The work is so well done that it is practically impossible to tell where the tool is welded and the performance of these tools is equally as good as that of the solid high speed steel tools. Fig. 1 shows a group of tools welded by the method described.

FRICITION.—Friction of lubricated surfaces is determined by the nature of the lubricant rather than by that of the solids or bearing metals themselves.—Power.

RUNNING AN ENGINE OVER.—The advantage of this is

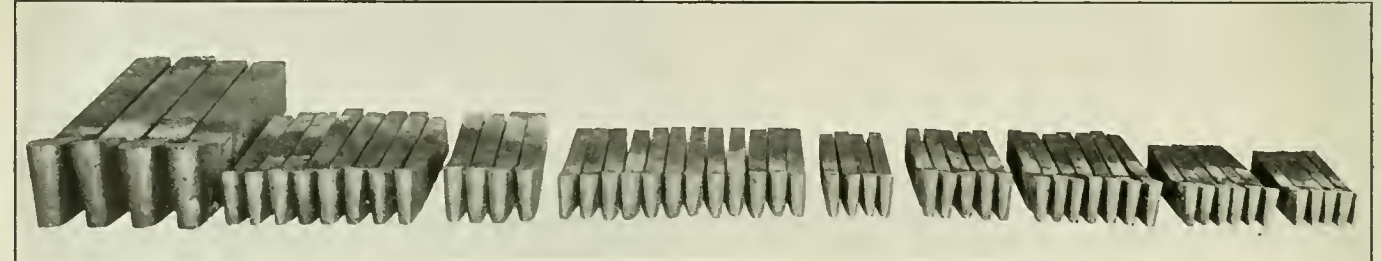

Fig. 1—Group of Lathe Tools with High Speed Steel Welded Tips

F. and the side that is welded to the carbon steel shank should be faced with Norway iron. In making the weld a good grade of special rolled steel must be used, the tip being welded to the shank by the oxy-acetylene process at the points indicated in the drawing. A large number of the carbon steel shanks and the high speed steel tips should be made up so that the work can be done quickly. This

that the pressure of the crosshead is always downward upon the guide. If the engine is run under, the thrust of the crosshead will be upon the top guide on both the outward and inward strokes, and unless the crosshead is properly adjusted, it will lift when subjected to thrust and fall by its own weight on the center, making the engine pound.—Power.

# ESSENTIALS OF SHOP EFFICIENCY

Discussion of the Features of Scientific Management Which Are Applicable to Railroad Shops

BY G. W. ARMSTRONG

Scientific management is by no means inapplicable to railroad work. A common mistake, however, is to disregard the fundamental fact that a railroad shop is not and cannot be handled as a manufacturing shop in the strict sense of the word. Its organization on the scientific basis of the best productive efficiency is impossible. Shop systems must be subordinate to the keeping of locomotives in service by reducing the time they are in the shop. With this essential for guidance, the principles underlying scientific management can be applied. Line and staff, standards, the time study and scheduling and routing all have possibilities in their application to railroad shops.

The size of the staff organization required is dictated

Having effected an organization, the first step must be a study of conditions with a view to improvement and standardization. This will require considerable detail, consume much time and owing to the absence of immediate tangible results will tend to a distrust of the value of the plan unless the full co-operation of the management has been secured. Plans should be worked up showing the various tool layouts and a thorough study made of the location of each tool with respect to its source of raw material and the destination of finished product. This study will undoubtedly indicate the advisability of relocating certain machines to promote greater efficiency.\*

Related to the determination of proper machine tool location is the preparation of the machine tool record cards shown in Figs. 1 and 2. The data on these cards enables a comparison of the productive efficiency of machines in the various shops to be made and serves a useful purpose in judging the possibilities for standardization of machine tool operations in the various shops. The preparation of these record cards will often reveal wide discrepancies in the speeds and speed changes of similar machine tools from different manu-

FILE NO. 453      MACHINE TOOL RECORD      DATE 9/30/15

MACHINE <i>Lathe</i>			
NUMBER 150	LOCATION Mach Shop		
SPEEDS LINE SHAFT			
CONE	BACK GEAR OUT      BACK GEAR IN		
STEP 1	512      252      44.0      21.6		
" 2	302      147      26.0      12.6		
" 3	181      88.5      15.6      7.6		
" 4			
" 5			
POWER FEED Friction HAND FEED			
SPINDLE SPEED			
STROKES PER MIN.			
LENGTH OF STROKE			
RETURN RATIO			
DRIVE <i>Belt</i>			
GRINDING TOOLS <i>Man</i>			
COOLING AGENT <i>None</i>			
FEED CHANGE <i>Lever and Gear Box</i>			
FEEDS			
THDS. 1, 1½, 1¼, 1⅜, 1½, 1⅝, 1¾, 2, 2¼, 2½, 2⅝, 3, 3¼, 3½, 4, 4½, 5, 5½, 6½, 7, 8, 9, 10, 11, 12, 13, 14, 16, 18, 20, 22, 24, 26, 28, 32, 36, 40, 44, 48			

Fig. 1—Machine Tool Record Card

DRIVING BELT <i>3 1/4 Double Ply Open Leather</i>	MANUFACTURER <i>H---L---C---</i>
CONE BELT " " " " " "	DATE INSTALLED <i>June 22, 1910</i>
	COST MACHINE <i>\$ 845.00</i>
	" INSTALLATION <i>\$ 22.00</i>
	WEIGHT
	FOUNDATION SIZE
	CLASS OF WORK
CUTTER	REMARKS:
TOOL SIZE <i>3/4 x 1 1/2</i>	
METHOD HOLDING TOOL <i>Sing. Screw Post</i>	
KIND OF STEEL <i>High Speed</i>	
SHAPE OF TOOL <i>Lathe Shapes</i>	
NO. OF TOOLS <i>One</i>	
TOOL HEAD <i>One</i>	

Fig. 2—Back Side of Machine Tool Record Card

wholly by the extent of the system to be covered. The duties of the various staff officers are the same for any size road although where the expense is unwarranted the functions of more than one may be vested in one person. Much of the success or failure of such an organization depends upon the man selected as its head, the efficiency engineer, shop specialist or whatever title he is given. He should be vested with sufficient authority to create respect for his orders and suggestions and yet in no way connected with the actual shop management, but reporting to the chief mechanical officer. The assistant engineer, or machine tool specialist, should be equally as capable as the shop specialist, but, primarily, he should have an intimate and thorough knowledge of machine tools. All matters relating to their maintenance and operation should be supervised by him and his opinion should have considerable weight in the selection of new equipment. Upon the shop demonstrators devolves the detailed work of the organization. From time studies made by them at the various shops are worked out the instruction cards, referred to later. Owing to the tendency to use them for other duties, these men should be under the jurisdiction of the shop specialist and should also be transferred from shop to shop at intervals in order that they may thoroughly acquaint themselves with the varying conditions at different points on the system. Should the establishment of a manufacturing department be considered advisable, the shop superintendent of such a plant should report to the shop specialist rather than to any local officer.

factors and in the installation of the same machine tools at different shops. As a preliminary to the preparation of standardized conditions, it is essential that these variations be corrected as much as consistent with the work performed. This alone in many cases will effect notable increases in efficiency, as many tools are not speeded to give the best results.

As an illustration of conditions of this kind actually encountered the diagrams in Figs. 3 and 4 are shown. These are for two 20-in. engine lathes purchased from the same manufacturer and installed at the same time. The lathe, the record for which is shown in Fig. 1, is another machine of the same type and from the same manufacturer. The three diagrams and accompanying data plainly illustrate the wide variations in speed changes which may exist between similar machines and show the necessity of standardizing conditions before attempting to realize any degree of standardization of methods.

Suppose a 12-in. valve chamber bushing is to be turned for

\*For a discussion of the location of machines see an article by the same author on "General Machine Tool Efficiency," on page 255 of the May, 1914, issue of the *Railway Age Gazette, Mechanical Edition*.

chamber fit, the material being a good grade of gun iron and the best speed for the feed and depth of cut being 35 ft. per min. If the work is performed on the machine shown in Fig. 1 the machine must be run on cone 3 with the back gears, at 7.6 r.p.m. or a cutting speed of 24 ft. per min. The next available speed, 12.6 r.p.m., gives 40 ft. per min., or a speed which would probably prove too high for economical work-

mendations for their correction. Too much care and caution cannot be exercised in the setting of time limits, nor in recording the conditions under which and for which each limit is set and the actual work and the degree of finish covered by each limit. A careful study should be made of these time studies and where feasible the best practice or a suitable combination should be drafted up in the form of an instruction

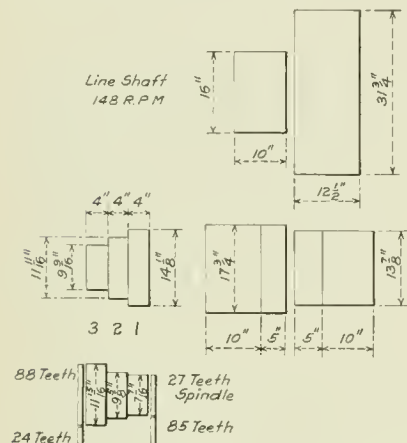

Cone	Open Belt		Back Gear In	
	Fast	Slow	Fast	Slow
Step 1	645.	254.	56.0	22.0
Step 2	411.	162.	35.6	14.0
Step 3	272.	107.	23.6	9.3

Fig. 3

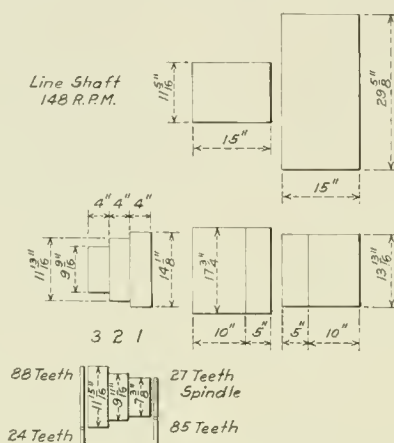

Cone	Open Belt		Back Gear In	
	Fast	Slow	Fast	Slow
Step 1	608.	181.	52.8	15.7
Step 2	388.	115.	33.6	10.0
Step 3	254.	76.	22.0	6.5

Fig. 4

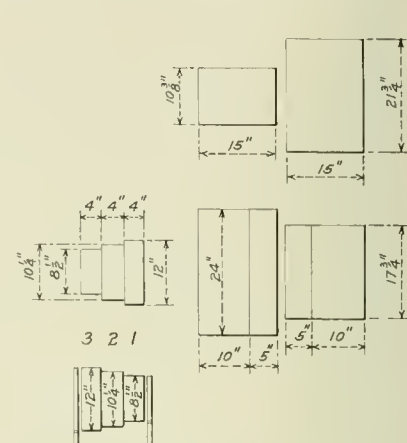

Cone	Open Belt		Back Gear In	
	Fast	Slow	Fast	Slow
Step 1	256.	905	320	113
Step 2	181.	64.0	22.6	8.0
Step 3	125.	45.2	16.0	5.66

Fig. 5

ing. Thus we encounter a loss of about 33 per cent from the most economical cutting speed. Trying the machine shown in Fig. 3, we find that by using cone 3 with the back gears a surface speed of 29.8 ft. per min. is obtained, while the next step gives 45 ft. Thus again a loss of efficiency is unavoidable. With the machine shown in Fig. 4 the best conditions are found as by using cone 2 with the back gears, a speed of 32 ft. per min., with less than 10 per cent loss in efficiency, is obtained.

card. The degree of refinement employed in making the time study and preparing the instruction card depends primarily upon the frequency with which the operation is repeated. Where possible one instruction card should be prepared for

It will be observed that the interval between the speeds is very irregular. While the machines have twelve speeds, some of these are so high as to be of little or no use and others are so close together that they almost coincide, thereby in reality restricting the number of speed changes available. These conditions are indicated by the logarithmic chart in Fig. 6. This gives the cutting speeds for various diameters of work with the available spindle speeds, for the lathe referred to in Fig. 1. At the top, on a scale of spindle speeds, are shown the intervals between the various speed changes, the irregularity between the steps being clearly brought out.

In order to overcome these disadvantages, Carl G. Barth has suggested the use of the geometric progression for machine tool spindle speeds. The speed change conditions of a machine so designed are shown in Figs. 5 and 7, a geometric progression with a ratio of  $\sqrt[3]{2}$  having been used. This gives speeds of 40 ft. per min. and 65 ft. per min. for the diameters ranging from 1 in. to 20 in., which are the most commonly used within the range of the machine. It will readily be seen from a comparison of the speeds available and the variations in these speeds that a lathe constructed similar to that in Figs. 5 and 7 possesses marked advantages for general work over the other machines.

The use of the time study is essential in the standardizing of methods. Upon the diligence and accuracy with which these studies are made rests much of the success of the efforts to increase efficiency. The operations should be thoroughly timed at the various points under differing conditions and with different operators, particular attention being given to feeds, speeds, cuts, special appliances used, methods of setting and notes as to inefficiencies with reasons and recom-

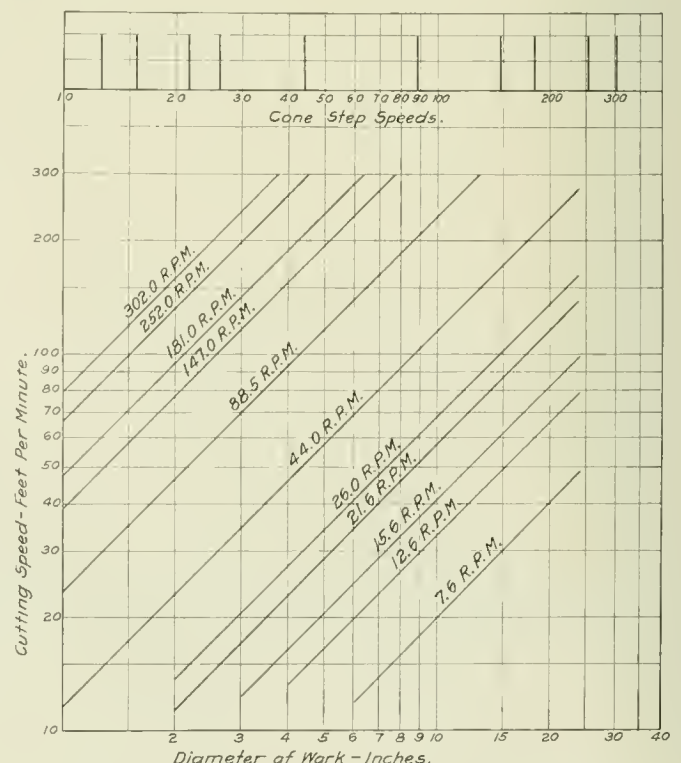

Fig. 6—Logarithmic Chart of Cutting Speeds of Lathe Referred to in Fig. 1

system use but often, owing to variations in the facilities at the various points, this is not feasible; in this case the minimum number possible should be used. Where operations, such as hydraulic press work, are performed at but one point,

time studies should be made independently by two or more shop demonstrators.

The instruction card gives the time allowance in detail with all necessary directions regarding special tools, appliances, method of setting, speeds, feeds, cuts, etc., and relieves both the workman and the foreman from the necessity of remembering any of the conditions. It becomes in reality a permanent record of the best practice for each operation.

Where instruction cards are completely and carefully prepared they may often serve to prevent drifting away from good, economical standards, through the loss of facilities. The possibility of this use of the cards is brought out by the following case, in which a special angle plate was constructed to hold eccentric halves, matching with a tongue and groove, for planing. As this ordinarily would necessitate an expensive set up, a large saving was effected and a reasonably small piece work price established by the use of the special fixture. In time, different workmen performed this operation and through lack of proper instruction, the jig was mislaid, the work being done without it. Soon the inevitable result followed; a complaint was made that the price was too

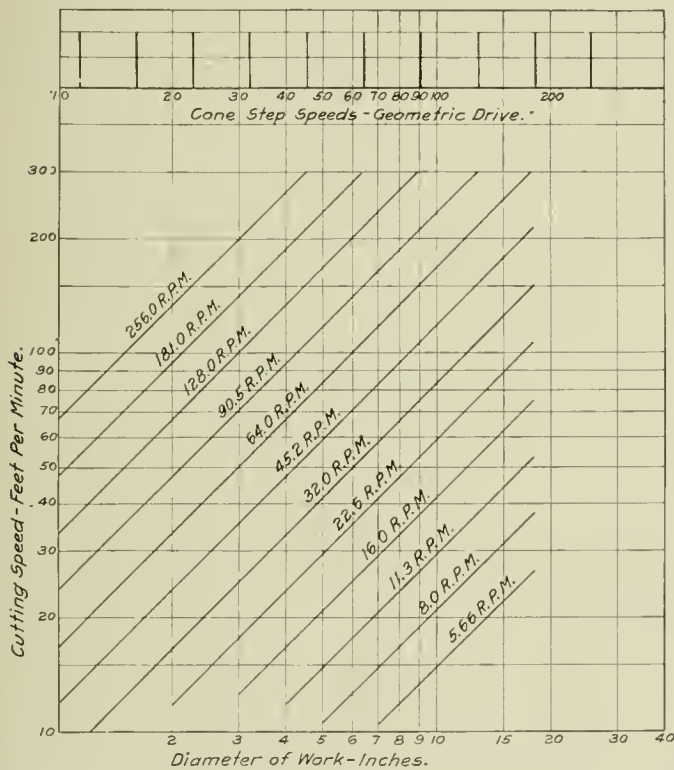

Fig. 7—Logarithmic Chart of Cutting Speeds of Lathe Referred to in Fig. 5

low. In the investigation some one was found who remembered the old jig, and when it was discovered and again placed in service no further complaint was received. Had an instruction card been used, the jig would never have been lost.

In the event of changing conditions as to material, size, machine tools and methods used, etc., the time studies and instruction card on file in the central office will serve as a means for quickly and thoroughly determining what effect these changes will produce and modified instruction cards can be issued.

The task of thus perfecting the method of performing each one of the innumerable operations occurring in a railroad shop would be one of inconceivable magnitude were it not for the great similarity of many operations and the possibility of developing new standards from the records of past performances combined with experience in their application.

While the foregoing has referred mainly to machine tool

operations, the same methods are applicable and should be utilized for all operations, including those performed in the erecting shop.

In addition to the record previously mentioned a card record should be maintained at the central office for each individual machine tool, giving a record of all breakages, defects and repairs. Data for this record should be forwarded monthly from the shops. The same index number should be assigned to this card as is assigned to the machine-tool record card. Such a record as that described will prove of inestimable value in comparing the service of various makes of machines, in locating weaknesses and giving opportunity to strengthen them and also in indicating whether the cost of maintenance is becoming prohibitive. Aside from these advantages it is useful as an aid to the proper selection of new equipment.

Closely allied with machine tool efficiency is belt efficiency. This is an item commonly given little attention in the average shop. To realize the maximum of belt efficiency at a minimum cost the selection of the right type of belt for the conditions encountered, must be made at the outset. The application and maintenance should then follow a definite standard practice. The methods to be standardized may briefly be stated as follows:

- Method of lacing.
- Tension to be maintained and means provided for securing it.
- Keeping belts clean.
- Insure that belts do not wear against guards, shifters, or flanges of cone steps.
- The use of a good belt dressing to keep belts pliable.
- The placing of belts on pulleys so the hair side is next to the pulley, and the outside lap trailing when running ahead.

A belt record should be maintained and periodical inspections made, in order to anticipate breakdowns. Repairs should always be made outside of working hours.

A careful study should also be made to establish a line of standard tools. When warranted by the extent of the system a specialist should be placed in charge of this branch, his duties including the study of the heating, forging, tempering and grinding of tools, as well as their shapes and sizes. To insure correct maintenance, the tools should, as far as possible, be supplied from a central point and repairs carefully checked to insure that standards established are maintained.

Opinions vary as to the details to be employed in scheduling and routing locomotive repairs, but to secure the best results, it is necessary to so schedule each important division of the work that nothing is left to chance. A careful working out of such a system will assist materially in a well-balanced distribution of the working force, enabling all departments to work effectively, eliminating petty complaints, delays and misunderstandings and tendency to an improved shop output.

Where the system is of any size a manufacturing department is a very useful adjunct in securing decreased cost of maintenance. Such a department should be entirely divorced from the repair shop organization and operated as an outside concern. The repairs on structures and machinery, depreciation, interest on investment, power, oil, waste, defective material, etc., should be accurately accounted for and the output charged to the various shops at a price sufficient to provide for all these indirect charges as well as the labor, material and supervision.

VALUE OF EXHAUST STEAM FOR HEATING.—Under average conditions the steam discharged as exhaust from a stationary engine can be made to accomplish about 90 per cent as much heating as when in the form of live steam discharged direct from the boiler. But from the waste incurred by drips and leakage of back-pressure relief valves, the heat that can be realized in average plants where exhaust is used for heating is probably not more than 80 per cent of that contained in the steam supplied to the engine.—*Power.*

**PROGRESS IN ELECTRIC ARC WELDING\***

Practically every large railroad shop in this country is using the electric arc process with metal electrodes for flue welding. Welded tubes are practically permanent since the tube and the sheet are bonded together without a joint, leaving virtually no chance for leaks to develop. It has been found that the tube sheet, after the tubes have been removed, is in better condition than where the tubes have not been welded in. The welding builds up the sheet around the holes almost to the original thickness. It is essential that only a first-class operator be allowed to do work on the repair of boilers, because of the dangers that are attendant upon defective workmanship where welded plates are subject to pressure.

Firebox repairs are closely related to flue-welding and are being made with equal success. They include cracks in the side, tube, door and crown sheets, leaky staybolts, seams, etc. Patches may be put on when the sheets have become weakened so that repairs are impossible. The carbon electrode is ordinarily used to cut out the defective part and a new section is then welded in place. Half-side sheets, door sheets, etc., are welded in without difficulty.

Broken locomotive frames are very successfully repaired by the use of the electric arc. The great advantage in this work is the great speed that may be obtained, as no dismantling of the locomotive is necessary beyond that required to give the welder access to the broken parts. There are cases where frames have been welded without drawing the fire.

The actual cost of repairs made in a large railroad shop in the middle west is tabulated below, with the cost of the method previously used to secure the same results. In some instances replacement was the only method possible until the electric arc was used. The arc welding costs were based on a power cost of 51 cents an hour with the carbon electrode, and 17 cents with the metal electrode, together with the cost of labor and an overhead charge of 40 per cent.

	Cost of welding	Cost by other methods
Plugging 51 holes in expansion plate, holes 1 in. diameter by 1/2 in. deep.....	\$2.75	\$10.15
Repairing mud ring.....	6.50	34.57
Cutting four 6-in. holes in tender deck sheet 1/2 in. thick.....	1.08	8.35
Welding eccentric strap, broken through neck.....	1.08	41.28
Welding two spokes in driving wheel center.....	7.98	99.98
Welding cracks in side sheets.....	26.15	31.79
Repairing firebox.....	134.89	869.58
Building up flat spots on locomotive driver.....	.40	225.00

On the last item the large saving is due to the making of the repair at the roundhouse without withdrawing the locomotive from service, while any other method would require a week or 10 days' loss of time while the locomotive was shopped and the drivers turned down. If the loss of time be considered the cost of the older method might easily be \$500 or more.

It has become universally accepted that a special motor-generator set gives the best results, because it supplies current of the necessary characteristics and does it at the lowest cost. The question that remains to be decided is the size of the set. Originally a separate set was supplied for each operator, but experience has proved that in a shop where two or more welders are employed it is better and cheaper to have one set supply several operators. Arc welding is necessarily an intermittent process, and hence the average load on the motor generator is low. Practice has shown that the arc will not be in use more than 50 per cent of the total time in most cases. This makes the cost of power higher than if the average load were nearer the capacity of the set.

Furthermore, the single set for several operators is cheaper to install than a set for each operator. The efficiency of the smaller set will of necessity be lower than that of the larger set. The general practice now is to install a motor-generator of sufficient capacity to supply all operators within a range of 500 to 600 ft. of the set with permanent wiring and outlet

\*From an article by J. H. Bryan in the February, 1916, issue of The Boiler Maker.

panels for the individual operators installed at the most convenient points where welding is to be done.

For miscellaneous repair work around large industrial plants a 300-ampere equipment, sufficient to allow two operators to work simultaneously with the metal electrodes, is usually satisfactory. Where more operators are employed for welding, and where carbon electrodes are used, it is usually desirable to put in a large set, though if the welding booths are scattered over a very wide area the use of several sets for two operators each may be found desirable. Individual consideration of the conditions must be made and the system best suited then installed.

**CHISELS\***

BY HENRY FOWLER

Chief Mechanical Engineer, Midland Railway

Very considerable attention has been given to the composition and treatment of tool-steel used in machine-tools, but the three implements of the hand worker—the file, the chisel, and the hammer—have been comparatively neglected. The author is aware of the work recently done in testing the former of these, and knows that there is little need of improvement with the last-named, but believes that the chisel has not received the systematic attention its importance deserves. A close ex-

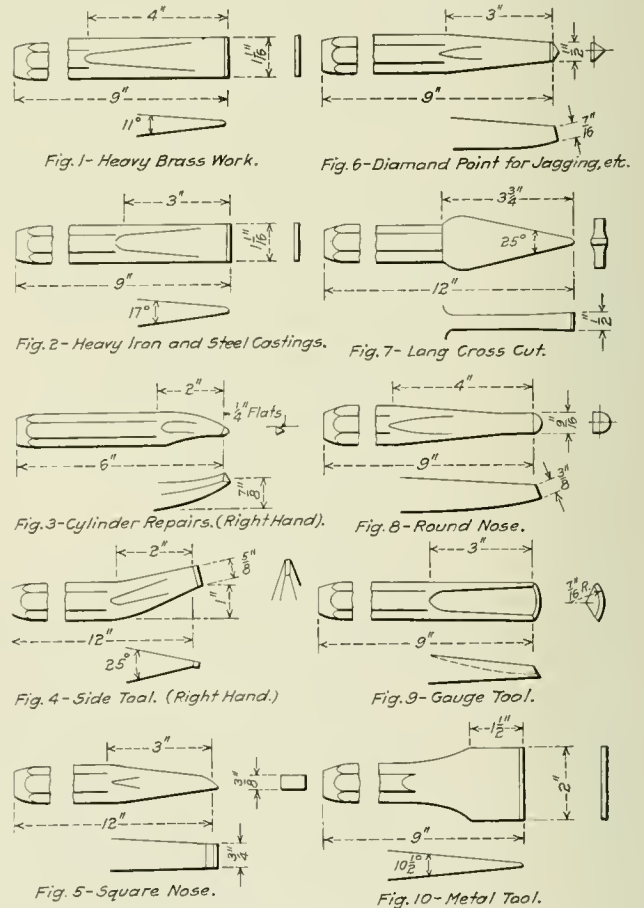

Chart of Standard Chisels

amination of the new and used chisels in the shop over which he had control, confirmed that view.

The material usually employed for chisels is not bought to specification, but a well-known and tried brand purchased. In the chief mechanical engineer's department of the Midland Railway, after considerable experiment it was decided to order chisel steel to the following specifications: "Carbon 0.75 per

\*From a paper presented before the Institute of Mechanical Engineers on February 18, 1916.

cent to 0.85 per cent, the other constituents being normal." This gives a complete analysis as follows:

	Per cent
Carbon .....	0.75 0.85
Manganese .....	0.30
Silicon .....	0.10
Sulphur .....	0.025
Phosphorus .....	0.025

It is perhaps interesting to note that the analysis of a chisel which had given excellent service was as follows:

	Per cent
Carbon .....	0.75
Manganese .....	0.38
Silicon .....	0.16
Sulphur .....	0.028
Phosphorus .....	0.026

The heat treatment this chisel received is unknown.

At the same time that chisel steel was standardized, the form of the chisels themselves was revised, and a standard chart of these as used in the locomotive shops drawn up. Figs. 1 to 10 show the most important forms of these, which are made to stock orders in the smithy and forwarded to the heat-treatment room where the hardening and tempering is carried out on batches of fifty. A standard system of treatment is employed here which to a very large extent does away with the personal element. Since the chemical composition is more or less constant, the chief variant is the section, which causes the temperatures to be varied slightly. The chisels are carefully heated in a gas-fired furnace to a temperature of from 730 to 740 deg. C. (1346 to 1364 deg. F.) according to section. In practice the chisel, Fig. 1, is heated to 730 deg. C., chisel, Fig. 2, to 735 deg. C. (1355 deg. F.), and a 1-in. half round chisel to 740 deg. C., because of their varying increasing thickness of section at the points. Upon attaining this steady temperature, the chisels are quenched to a depth of 3/8 in. to 1/2 in. from the point in water, and then the whole chisel is immersed and cooled off in a tank containing linseed oil. This oil-tank is cooled by being immersed in a cold-water tank through which water is constantly circulated. After this treatment, the chisels have a dead hard point and a tough or sorbitic shaft. They are then tempered or the point "let down." This is done by immersing them in another oil-bath which has been raised to about 215 deg. C. (419 deg. F.). The first result is of course to drop the temperature of the oil, which is gradually raised to its initial point. On approaching this temperature the chisels are taken out about every 2 deg. C. rise and tested with a file, and at a point between 215 deg. C. and 220 deg. C. (428 deg. F.) it is found that the desired temper has been reached, the chisels are removed, cleaned in sawdust, and allowed to cool in an iron tray.

A question which naturally will be asked is whether comparative tests of these chisels with those bought and treated by the old rule-of-thumb methods have been made. It must be admitted that the author knows of no method of carrying out such tests mechanically, other than that of hardness by the Brinell or scleroscope method, while any ordinary test depends largely upon the dexterity of the operator. The universal opinion of foremen and those using the chisels of the advantages of the ones receiving the standard treatment set out has, however, convinced the author of the improvement made.

Questions may be raised as to why the chisels have not been normalized at about 900 deg. C. (1652 deg. F.) after forging and before hardening. This matter had attention when the question was first dealt with, but at that time there were no facilities for carrying out this work. These have since been provided in connection with certain other work, but although various chisels have been normalized in the manner mentioned, no advantage has been found in carrying this out.

EFFECT OF INSIDE LAP.—Addition of inside lap causes the exhaust to open later and to close earlier, with more compression and greater cushioning effect of the exhaust.—*Power.*

## OPERATING A LARGE ENGINE TERMINAL\*

BY F. W. SCHULTZ

District Foreman, Union Pacific, Grand Island, Neb.

A foreman who, through promotion, is placed in charge of a large and long-established engine terminal, regardless of facilities, does not have the job on his hands that a foreman has who takes charge, as an entire stranger, of some terminal where it is necessary to make an organization. Organization is a big study in itself, and it is a first-class organization that gets results. No matter how good a terminal may be as to facilities, it will not run itself. Supervision means a good deal, and plenty of it can be had in any organization. The best engine terminal organization is one in which when a man drops out for any cause he is immediately replaced by not only a good man but perhaps a better man. Understudies in all departments are necessary, and a live foreman should so know his organization as always to have a good man to promote. Develop an organization so that each department reports to the various heads, such as clerks to the chief clerk, foreman to the general foreman, helpers to their respective mechanics and hostler helpers to the hostlers. Where there are three fire builders, one should be the lead man; foreign laborers always work well together with a lead man. If only two blacksmiths are employed, one should be the lead man. It does not look well, and does not get results without causing friction, for a foreman to tell a hostler's helper to tell the hostler what he wants to do any more than it would look well for the general foreman to issue orders direct to an employee, ignoring his subordinate officer. If he desires to investigate a matter, or issue instructions personally, he should be considerate enough to take a subordinate officer with him. One man can handle no organization alone. He must have good subordinates, and by establishing such a system it will give the general head time enough to calmly think over matters and also take time to see for himself how things are going. Foremen should see what they can without asking too many questions. It is a poor time to investigate a piece of work after some irregularity has happened.

When two men are set to work on a piece of work at equal pay and are to be left alone any length of time, one man should be the lead man. When a man does a certain piece of work, he likes to know how well he has done it, and if a foreman finds a man's work is good he should say so. Nine times out of ten the man performing this piece of work will do the work quicker next time and try to do it better; therefore the foreman gets results.

Systematic promotion of men should be practised. Very often an employee with an intermediate rate of pay leaves the service. Some foremen have instructions not to fill such a vacancy. This is a mistake. Men who have not received this rate of pay are looking forward to this increase, and, when several men can be advanced, it increases the efficiency of the men because of their receiving encouragement and better pay. They usually begin at once to improve themselves for a still bigger job, which is getting results. An employee in any organization, who has a good idea, or discovers some irregularity and reports it to the foreman, should immediately receive commendation, and if his accomplishment is great enough to warrant it he should receive an increase, however small. Censure may do much, but encouragement does more.

Men in any organization appreciate clean, orderly and sanitary premises. This gets results by teaching order and cleanliness.

Modern locomotives which have outgrown a roundhouse are housed very often with part of the tender sticking out of the door, and at zero weather, or colder, this plays havoc with both men and equipment. Some enginehouses have a few stalls to accommodate part of the large power. A live foreman should see that his mechanics do not have to bundle

\*Entered in the Enginehouse Competition which closed February 1.

up with so many clothes that they will be "clothes-bound," and should either put an engine in the house or leave it out. The greatest mistake a foreman can make is to do a day's work on an engine under such conditions without cutting off the tank, closing the doors, and showing his organization that he has their welfare at heart. Many a man has slighted a job, said mean things about a foreman and done a good deal to poison the rest of the organization, because the foreman has told him to put on some clothes to keep warm and go on back to work, forgetting that a man who is too heavily bundled up cannot handle any class of work effectively. Nowadays when there are seven or eight different nationalities employed in a large terminal employing 300 to 500, and repairing from 75 to 125 engines daily, a foreman must step into the plant as a diplomat and see that there is no friction. Employees in their various stations are continually looking to some man whom they consider above them, principally for their own welfare. If a foreman encourages them it spreads through the organization and gets untold results.

As regards facilities, there should always be two incoming tracks as well as two outgoing tracks to the turntable. Care must be taken not to mix the direction of traffic. Usually tracks can be placed on each side of the coal chute. If the roundhouse is too small, there should be enough storage tracks outside so as to accommodate the overflow. Any roundhouse can be well lighted, and if steam heat is not enough in pit pipes, stoves can be placed in the house. Up-to-date engine houses usually have heat enough from steam heating plants. There should be a vise and a work bench between every two stalls; also a small machine room adjacent to the roundhouse, centrally located, with proper machine tools and a few of the ordinary supplies which are used daily. It pays to put a man in charge of such a room and the tools, with instructions immediately to see that defective tools of any kind are repaired. Mechanics assigned to special work should be given special tools to be kept along with their private tools. A metal bench block riveted to the bench prevents the using of a vise as an anvil. The closer facilities are placed to the work, the less steps high priced labor will have to take. High priced mechanics required to push a truck instead of doing skilled work is labor misdirected.

An experienced foreman should know his various classes of power just as well as he should know each mechanic. Engine failures are avoided by knowing when to keep a weak engine off the road.

A foreman who is getting near the 100 per cent efficiency mark usually maintains a permanent organization, as no company or manager is going to disrupt any organization by requiring a reduction in force when results are nearly perfect. It should not be forgotten that regardless of facilities the one important matter is to make an organization and maintain it. The continued getting of results shows a stable organization and one that is handled properly. The best thing for any foreman to do in case he is not getting results is to investigate himself. He may be ever so conscientious, but he may need some experience; above all things, he should never allow prejudice or sentiment to enter into business.

**ADVANTAGES OF POPPET VALVES.**—The main advantages of poppet valves are that they have no wear from movement on their seats, and requiring no lubrication, they are better adapted to the use of superheated steam.—*Power.*

**BOILER EXPLOSIONS.**—The mechanism of a boiler explosion known as the Colburn Clark theory is as follows: An initial rupture; sudden, rapid reduction in pressure; the formation of a great quantity of steam in the water, hurling the water at the opening, increasing the latter and shattering the boiler; completion of vaporization of the liberated water, projecting the parts to distances depending on the violence of the expansion.—*Power.*

## RECLAIMING DRIVING BOXES

BY R. P. PETERMANN

Tool Foreman, Atlantic Coast Line, Waycross, Ga.

The Atlantic Coast line has been increasing the life of driving boxes by placing brass liners on the shoe and wedge faces. The box is dovetailed and heated, and is then jacked open before the brass liner can be poured, which takes a great deal of time. In addition, it is possible to obtain only an average of one shopping out of brass liners as the metal is so soft that it either works loose or pounds out at the ends of the box.

The illustration shows a box with a steel boiler plate liner applied. With this method it is necessary to true up

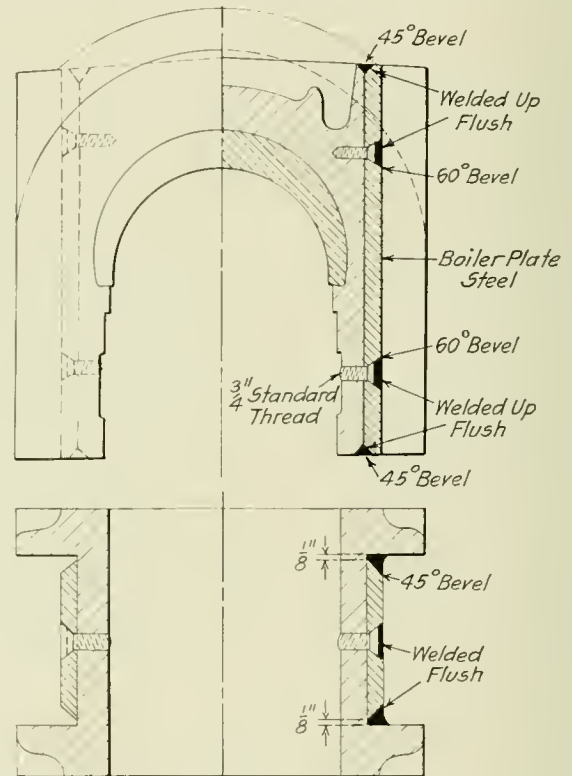

Driving Box with Steel Plates on the Shoe and Wedge Faces

the box on a planer and plane the radius out of the corners so that the liner can be welded all the way up. This welding is done by an electric welder. The plates are pulled down solid by means of two countersunk  $\frac{3}{4}$  in. screws and the heads of the screws are welded to prevent their getting loose. This method of reclaiming driving boxes is a great deal cheaper than using the brass liners, and it is believed that it will result in at least twice the amount of service from the box.

**STOP-COCKS FOR BOILER PRESSURE GAGES.**—The connection of a steam gage should be so arranged that the gage cannot be shut off from the boiler except by a cock placed near the gage, showing at a glance whether the cock is open or closed. To fill this requirement the cock should be provided with a tee or lever handle arranged to be parallel to the pipe in which it is located when the cock is open.—*Power.*

**WETTING DOWN SLACK BEFORE FIRING.**—Although moistening fuel detracts from its heat value, the loss is usually more than compensated by prevention of dust in handling and, especially where there is a strong or forced draft, wetting down will generally be of advantage to prevent fine fuel particles from being caught up by the draft and deposited on the heating surfaces of the boiler or swept out of the chimney unburned coal or ashes.—*Power.*



# NEW DEVICES

## UNIVERSAL NON-PACKING VALVE

According to the report of the chief inspector of locomotive boilers for the Interstate Commerce Commission 1,770 locomotives were found defective during the past fiscal year on account of leaking valves. This defect is principally due to improperly applied or worn packing in the stem of the valve. To eliminate trouble and defects of this sort, valves which require no fibrous packing have been developed by the Universal Valve Company, Karpen Bldg., Chicago. The construction of these valves is shown in the illustration. They are made up of a handle .1 which has a free fit on a

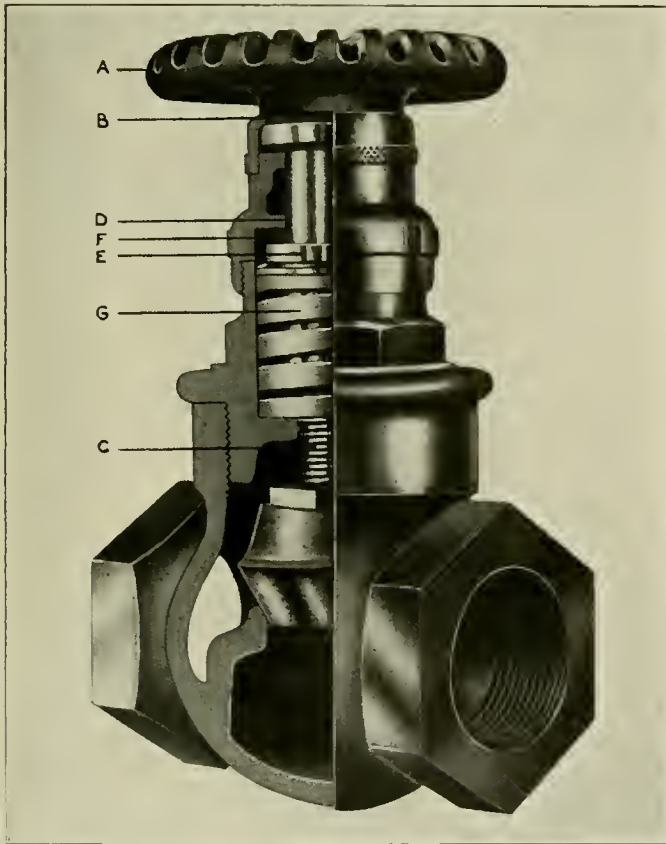

Universal Non-Packing Valve

square shank of an auxiliary valve stem *D*. The handle is held in position by the collar *B* which is screwed onto the body of the bonnet. The auxiliary valve stem *D* is provided with a square socket to receive a square shank on the end of the main valve stem *C*. This member is threaded into the bonnet as indicated in the illustration and is raised or lowered as the handle is turned, a square socket in the auxiliary valve stem being sufficiently deep to always engage the shank of the main valve stem.

The shoulder *E* on the auxiliary stem is grooved on its upper surface and bears directly on the babbitt ring *F* and is held in permanent contact with that ring by the cast-iron spring *G*. This forms a sufficiently tight joint with but little spring tension. It is guaranteed by the maker to last the life of the valve under high and low pressures and at temperatures ordinarily met with in the use of saturated and super-heated steam. The spring is made of cast-iron under the Knudsen patent, as this material has been found

to better withstand high temperatures than a steel spring. In view of the construction of this valve it will withstand unusually hard service without its operation being affected. The company making this valve is in a position to make the entire valve or only the bonnet for application to valves of other makes. The composition of the babbitt ring is varied to meet the temperature requirements. These valves have been in successful service on locomotives, high pressure steam plants, hydraulic systems and piping systems for the lighter gases such as oxygen, acetylene, etc.

## MACHINE FOR GRINDING REFLEX WATER GLASSES

A machine for grinding reflex water glasses is being manufactured by H. B. Underwood & Company, Philadelphia, Pa.

It is simple in construction with very few wearing parts which are protected from coming in contact with the grinding material, thus avoiding unnecessary wearing of parts. The only part which is likely to require attention is the removable loose grinding disc, which can be redressed or replaced at little cost. The machine can be operated by unskilled labor and with cheap materials. It consists of a revolving table .1 to which motion is imparted by an air mo-

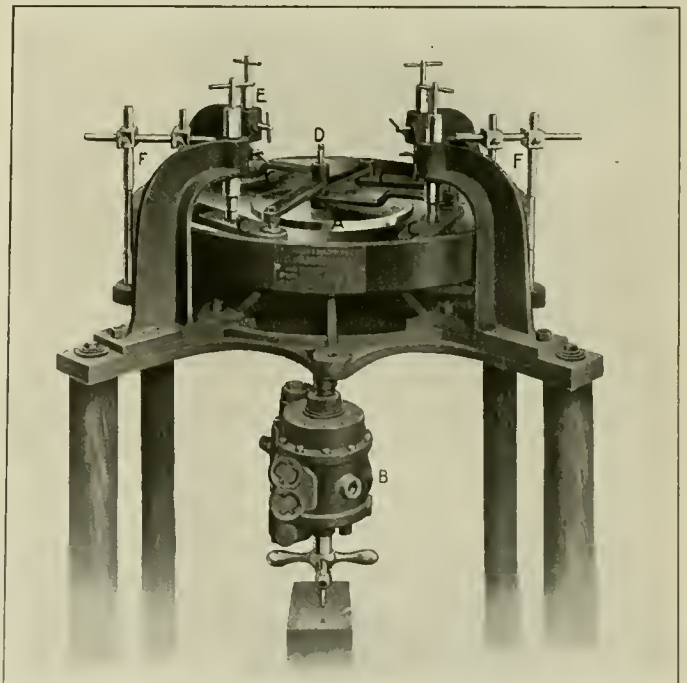

Reflex Water Glass Grinding Machine

tor *B* running at 100 to 125 r. p. m., and four glass holders *C* which are given an oscillating motion by the pin *D* set eccentric with the table. This prevents the glass running in a concentric groove and avoids scratching or cutting it in ridges. The glasses are held under a flexible pressure, which can be regulated to the required amount by the pressure device *E*. The grinding compound is kept in contact with the glasses by two spreaders *F* placed diametrically opposite each other.

## BORING BAR FOR CYLINDER AND VALVE CHAMBER BUSHINGS

Safe guarding all moving parts of machine tools, both stationary and portable, has become not only desirable but, in many states, obligatory. In the new design of the Rooksby portable boring bar, the manufacturers have been guided by the "Safety First" principle and have carefully guarded all exposed gears and moving parts.

These machines are designed especially for re boring locomotive cylinders and valve chamber bushings. They can be used with one or both cylinder heads removed and are easily and quickly set up. The crosshead blocks are bolted to the cylinder with the cylinder head studs and the bar revolves in the sleeves supported and centered by set screws in the crossheads. When boring with only one head removed, the expanding chuck and pin, having five sets of taper gibs to fit in stuffing boxes of various diameters, is used to support the crank end of the bar.

The power is applied to the bar by means of a back geared driving power having a two speed quick change gear drive. This is a recent improvement and is of particular advantage where the same bar is used to re bore cylinders and valve chamber bushings of various sizes. The quick change is accomplished by simply pulling out a slip pin.

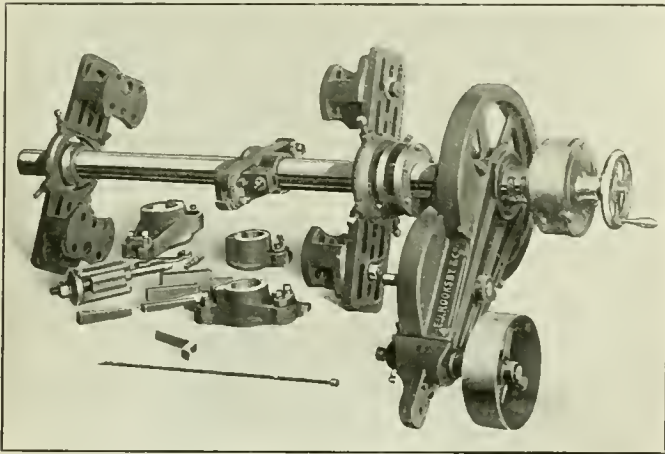

Portable Boring Bar for Cylinders and Valve Chambers

shifting the primary pinion out of gear and driving by the intermediate shaft. There has also been designed an improved tool holder using high speed cutters for extra hard service. The cutter head is fed by means of an automatic feed case having two changes of feed controlled by a slip pin. This is also completely encased as shown in the engraving.

For setting the bar up in valve chamber bushings, a novel device is used enabling the operation to be quickly and accurately performed. This consists of a set of taper cone sleeves in halves, fitting in the counterbore, supporting the bar in a central position while the blocks and crossheads are being bolted up, after which the cones are removed and the bar is ready for re boring. The sleeves being taper, one set can be used in bushings of various sizes within their range.

These portable boring bars are manufactured by E. J. Rooksby & Company, 431-439 N. 11th St., Philadelphia, Pa.

**MANGANESE STEEL.**—This steel has the peculiar property of being toughened and softened by quenching in water, resembling copper in this respect. All manganese steel castings are subjected to this treatment to remove brittleness. It has found its principal application in castings for crushing and grinding machinery and railroad crossings.

## CHUCK FOR DRIVING TAPS

Considerable trouble is experienced with the ordinary methods of driving taps in getting them to run true. This is detrimental both to the quality of the work and the life of the tap and is due to the fact that the shanks and squares of the taps vary considerably in size. These variations have made it very difficult to secure uniformly satisfactory operation with the type of holders generally used. A simple tap chuck for use in the drill press spindle, which is designed to overcome this difficulty, is shown in the drawing. This device is known as the True Drive tap chuck and has recently been placed on the market by Scully-Jones & Co., Chicago.

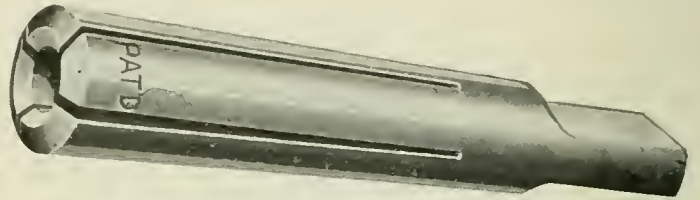

Simple Tap Driving Chuck

The chuck is made in one piece, the body being split into four segments for a distance of from two to four inches from its lower end. The square head of the tap is placed in the socket of the chuck, and as the latter is driven up into the Morse taper socket of the drill spindle, the segments of the chuck are tightly closed against the head of the tap. The chuck socket is of square section to correspond with the square of the tap, thus providing for a positive transmission of the drive. The chuck is of hardened steel, and this, together with the manner in which it is used, are claimed to make it almost indestructible.

## MOORE TYPE REFRIGERATOR AND HEATER CAR

The Moore type of car is designed to meet the requirements for the transportation of perishable freight under all weather conditions. It is a combination refrigerator, ventilator and heater car. Its general construction is the same as that of any refrigerator car with the substitution of a live air space about 1½ in. wide in the sides, ends, floor and ceiling of the car in place of the usual dead air space. This space is connected to the interior of the car by a ¾-in. slot in the inner lining located about 4 in. above the floor, and to the ice box at the top of the car, as shown in the illustrations. The purpose of this live air space is to assist in the matter of circulation and to completely surround the contents of the car with a wall of cold or warm air, according to whether it is used as a refrigerator or a heater car. The interesting feature in the arrangement of the Moore system is the means employed to secure a positive and active circulation of air throughout the entire car, no matter in which service it is used.

The ice box is located in the center of the car directly under the roof. It is substantially supported by T-beams and is loaded through six hatchways in the roof. The ice box has three openings into the car, one at each end and one in the center. Through the opening in the center the cold air is discharged into the car, as indicated by the arrows in Fig. 1. The cold air falls to the floor and tends to spread out over the bottom of the car towards each end. The warm air rises and enters the ice box through a netting at the end where it is cooled and again passes through the opening in the center of the ice box into the car chamber. The cold air is also drawn into the live air space through the opening in the sides and ends of the car by the rising warm air which passes through this space to the ice box, where it is again cooled and discharged through the middle opening of the ice box. Tests made with this type of car under refrigeration show-

that an even temperature is obtained throughout the entire car. This positive circulation not only gives the proper refrigeration but has a drying effect, which is of decided advantage when perishable freight is being transported. The dampness, being taken up by the warm air, is carried to the ice box and there condensed and deposited on the ice, where it is washed away with the drippings from the ice box. There are four drains which carry away the melted ice, two being located on each side of the car and discharging underneath the car well outside of the tracks and away from the trucks.

through temperatures as high as 110 deg. in the sun and 96 deg. in the shade. The temperature record at the top of the fruit is especially noteworthy, as it was only 3 ft. from the ice box. It was also stated in the report of this test that throughout the test the fruit did not show any sign of moisture to the extent that usually is shown on refrigerated fruit due to condensation. This undoubtedly is due to the good circulation obtained in the car. Comparative tests with the end ice box cars have shown that the Moore cars consume from 50 to 60 per cent less ice under the same conditions,

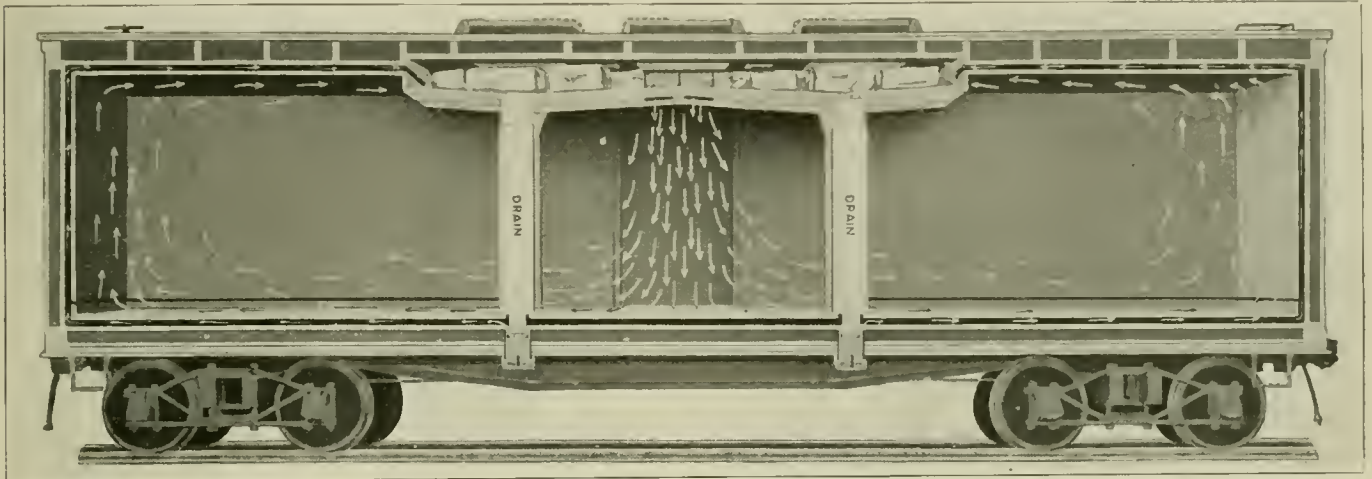

Fig. 1. Moore Type Car in Use for Refrigeration

There is no opportunity for the water from the melted ice to cause rotting and corrosion.

The accompanying table, which is a report of a test made on one of these cars, illustrates the even temperature maintained throughout the car while under refrigeration.

	Floor Front.	Floor Center.	Top Fruit Center.	Floor Rear.	Outside Temp.
Friday, 11:00 a. m.....	64	64	64	64	82
Friday, 6:00 p. m.....	62	62	62	62	78
Saturday, 7:30 a. m.....	62	62	60	60	68

due to the fact that with good circulation less ice is required.

The ice tanks, being built directly under the roof of the car, do not occupy valuable space, as do the ice boxes in refrigerator cars equipped with end ice boxes. By this means it is possible to carry from 20 to 25 per cent more freight in a Moore car than in an end ice box car of the same dimensions. The rigid construction of the ice box also provides a valuable reinforcement to the superstructure of the car. A possible objection might be raised due to the raising of the

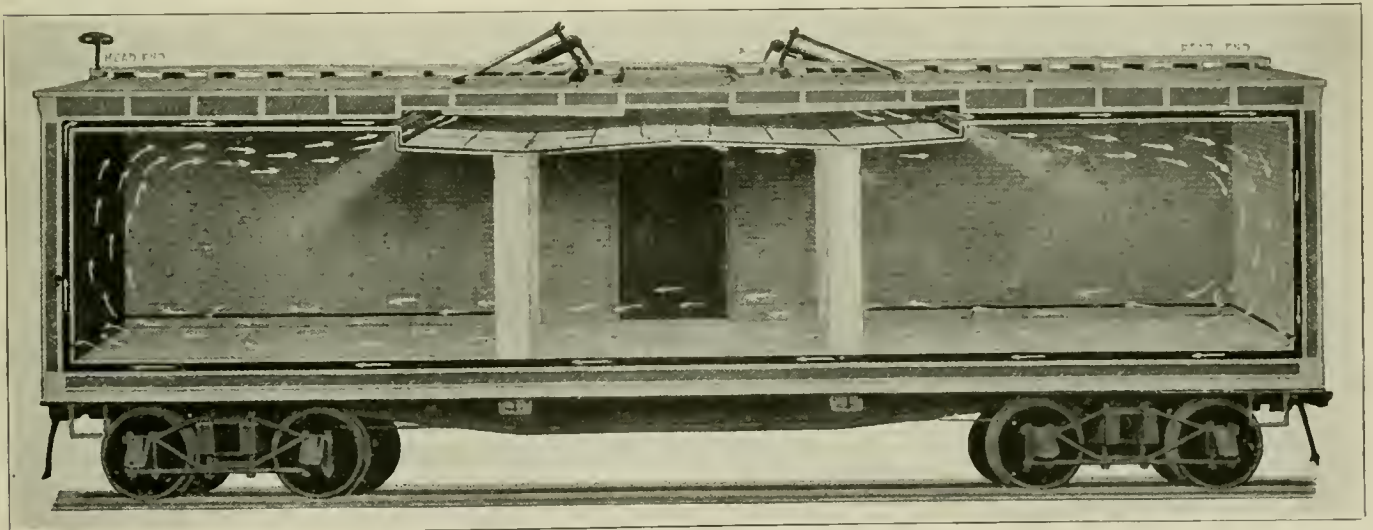

Fig. 2. Moore Type Car Under Ventilation

Saturday, 5:15 p. m.....	64	62	62	64	76
Sunday, 11:05 a. m.....	64	64	64	64	78
Monday, 6:00 a. m.....	70	70	70	70	74

This car was loaded with 320 bunches of bananas, the temperature of the fruit when placed in the car being about 64 deg. A high temperature is required for banana service. To obtain the desired temperatures in this test refrigeration and ventilation were used at the same time, all plugs being out and all vents being partly open. The car was sent from New York to Toledo, Ohio. Throughout the trip it passed

center of gravity of the car by placing the ice in such a high position, but it has been calculated that this figure will not be increased materially, it varying from one to two inches higher than refrigerator cars using the end ice box system.

When this type of car is used as a ventilator car the front and rear hatches are raised to an inclined position, the rear hatches being open to the direction of travel and the forward hatches away from the direction of travel. The air passes into the car through the rear hatches, passing down into the

ice box and into the car itself through the grating at the rear end of the ice box. The tendency is for this air to pass along the ceiling to the end, thence downward, back along the floor to the front end and out through the forward hatches, the suction caused by the outer air passing over these hatches assisting to remove the air from the inside of the car. The action of the air when the car is used in this service is well shown by the arrows in Fig. 2. Records of the temperature taken with one of these cars under ventilation loaded with 317 bunches of bananas show the same uniformity of temperature as was obtained when the car was running as a refrigerator car. The following table gives the temperatures at various parts of the car on a shipment from New York City to Dunkirk, N. Y.:

	Ceiling.	Floor Front.	Floor Center.	Top Fruit Center.	Floor Rear.	Outside Temp.
Friday, 11:00 a. m.....	74	64	64	62	64	76
Friday, 7:00 p. m.....	68	60	60	60	60	74
Saturday, 7:00 a. m.....	64	60	60	60	60	66
Saturday, 4:30 p. m.....	70	66	64	66	68	74
Sunday, 10:30 a. m.....	68	66	64	66	66	66

On arrival the fruit was green and cool. In the report of these tests it was stated that although this was not as severe a test as could have been made, the results show that the Moore system of ventilation is to be considered superior to the end system of ventilation. Bananas are a difficult product to transport without deterioration.

When the car is to be used to carry perishable freight under heat a coal stove is provided, as shown in Fig. 3. It is carried in an insulated box located under the car at the side near the door, and is operated entirely from the outside. It heats the fresh air taken from an intake located directly beneath the stove. This air surrounds the stove and chimney, passing up through the heating drum, and enters the car near the top, displacing the colder air, forcing it down through the live air space and off the floor of the car into the live air space under the floor, where it passes into the heater box whence part of it goes out through the waste air pipe which is connected to the chimney and part is reheated and passed back into the car. The arrows in Fig. 3 show the action of the circulation of the air in the car. The stove used for

west, and it has been found entirely adequate to handle perishable freight in the coldest weather. The rights for the use of this car are now controlled by the Refrigerator, Heater & Ventilator Car Company, St. Paul, Minn.

### LUBRICATOR FOR LOCOMOTIVE AIR PUMPS

The subject of locomotive air pump lubrication is one which has not been given a great deal of consideration by the mechanical departments of most of the railroads of this country. The lubrication of the steam cylinder is usually taken care of in one of three ways:

Where locomotives are equipped with hydrostatic lubricators for lubricating the engine cylinders, an additional

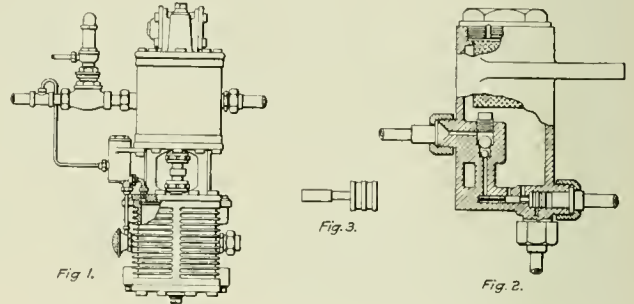

Air Pump Lubricator for Both Air and Steam Cylinders

feed is supplied on the lubricator and connected to the steam cylinder of the air pump;

Where locomotives are equipped with force-feed lubricators for lubricating the engine cylinders, an additional pump is supplied for furnishing lubrication to the steam cylinder of the air pump;

In some instances a separate single feed hydrostatic lubricator is applied to the locomotive.

None of these schemes is entirely satisfactory, as, in the

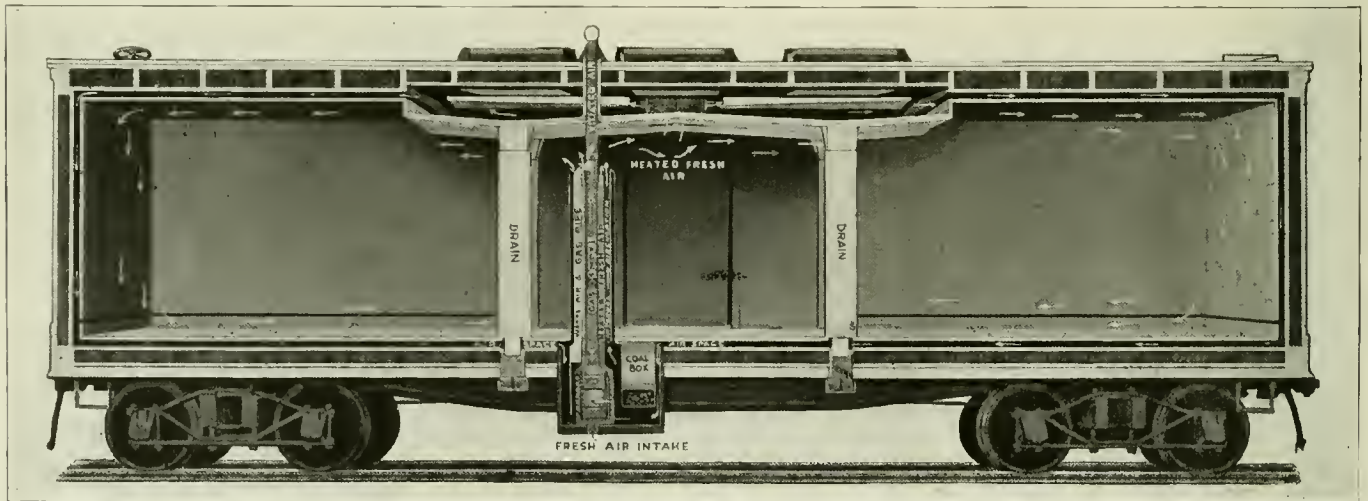

Fig. 3—Moore Type Car Arranged for Heating the Lading

heating is simple in construction and may safely be operated by inexperienced men. The coal used in the stove is carried in the coal box directly alongside of the stove. Pea coal has been found to give the best results, although any kind of fuel can be used in case of necessity. Results of tests with this type of car used as a heater have shown that a uniform temperature can be maintained throughout the car, and that the air in the car is maintained in a particularly clear and pure state. The heater car has been made standard on three prominent roads operating in the North-

first case, the lubrication of the steam cylinder of the air pump is placed in the hands of the engine crew, with the natural result that oil is fed continuously, regardless of the amount of work which the pump is doing. This objection applies also to the third scheme.

The second scheme is open to the objection, and it is a serious one on heavy freight power, that lubricant is furnished the steam cylinder of the air pump when the locomotive is in motion only, and it will be fully appreciated that it is at this time that the air pump on a heavy freight

locomotive requires the least amount of lubrication. When a locomotive so equipped makes a stop with a long train the air pump is usually required to make several hundred strokes in recharging the train line, during which time it will in many cases become so dry as to interfere seriously with its operation and efficiency.

The lubrication of the air cylinders of locomotive air pumps is generally taken care of even more inadequately than is the lubrication of the steam cylinders. Neither the hydrostatic lubricator nor the ordinary force-feed lubricator is a satisfactory device with which to lubricate the air cylinders, as in either case the oil is introduced in amounts in excess of what is required, and in a form which is not best suited to the lubrication of the hot dry cylinder walls and the valves. It is the practice generally to introduce oil into the air cylinders through what is commonly known as an oil cock applied to the top head. With this arrangement someone is depended upon to fill the cup with oil, open the cock and allow it to flow down into the cylinder when the pump is not in operation. This method is not conducive to good results on account of the fact that as a general proposition oil is not applied until indications of its need are observed; also on account of the fact that when oil is introduced it is in such quantities and in such form as to carbonize on the walls of the cylinder and to gum up the discharge valves. Further, the lack of facilities for properly lubricating the air cylinder leads to the objectionable practice of pouring oil on the outside of the intake strainer, which tends to gum it up, causing dirt to collect in such quantities as to restrict the free passage of air through the intake, and interfering with the capacity and efficiency of the pump.

With the view of overcoming these difficulties and furnishing lubrication to air pumps in proportion to the amount of work done, the lubricator illustrated has been designed by O. C. Wright, assistant engineer of motive power, Pennsylvania Line, Fort Wayne, Ind., and patents applied for. Fig. 1 shows the lubricator as applied to a Westinghouse 9½ in. air pump. Fig. 2 shows a section through the operating parts of the lubricator; Fig. 3 shows the operating member of the lubricator in detail.

Referring to Fig. 1, it will be noted that three connections are made to the lubricator. No. 15 leads to the pipe supplying steam to the steam cylinder; 12 to the top head of the air cylinder, and 14 to the air inlet of the air cylinder.

Referring to Fig. 2, it will be noted that connection 12, being made to one end of the air cylinder, provides a means for creating alternate vacuum and pressure in the cavity *P*, which produces a reciprocating motion of the operating member; in other words, one cycle of the air pump produces a complete stroke forward and back of the operating member. In the backward stroke a quantity of oil is drawn from the cup *L*, through the port *V*, into chamber *Q*, a part of which on the forward stroke is forced through the passage *V*, past the double ball check valves 5 and 6, into the connection 15, and thence to the steam supply pipe of the steam cylinder. Simultaneously with this operation on the back stroke of the operating member a small quantity of oil is drawn from the cup *L*, through the port *U*, into the chamber *P*, and on the forward stroke part of the oil is forced through port *S* into connection 14, thence through the air inlet past the inlet valves and into the air cylinder. This oil enters the cylinder in an atomized state on account of its mixture with air during its ejection from chamber *P*. From the foregoing it will be noted that on each stroke of the pump a quantity of lubricant is supplied to both the steam and air cylinders, which quantity can be regulated by the proper proportioning of the ports *U* and *V* and locating them with proper relation to the limits of travel of the

operating member. It will be noted from Fig. 1 that the bolting flange *J*, Fig. 2, is attached to the lower steam cylinder head, which not only serves as a convenient method of supporting the lubricator, but also affords a means of conducting heat from the steam cylinder, maintaining the oil in the lubricator at practically constant temperature under all weather conditions.

It is believed that the application of this device will be found to result in not only a reduction in the amount of oil used and the number of train detentions on account of air pump failures, but also in an appreciable reduction in the cost of maintaining the pumps.

## COMPOUND-GEARED PNEUMATIC DRILL.

An exceptionally powerful, compound geared pneumatic drill motor has recently been brought out by the Ingersoll-Rand Company, 11 Broadway, New York. This drill is reversible and is designed to handle the heaviest flue rolling, drilling, reaming and tapping. It is particularly adapted to tapping operations on flexible stay bolt work, running-in stay bolt sleeves, locomotive valve setting, and other heavy duty operations. The construction is such that it develops full power on the reverse as well as the forward motion. This is of particular advantage in applying flexible stay bolt sleeves as, after the sleeve has been set up tight, it is possible to unscrew the sleeve cap by reversing the motor. This obviates the necessity for the usual cumbersome wrench.

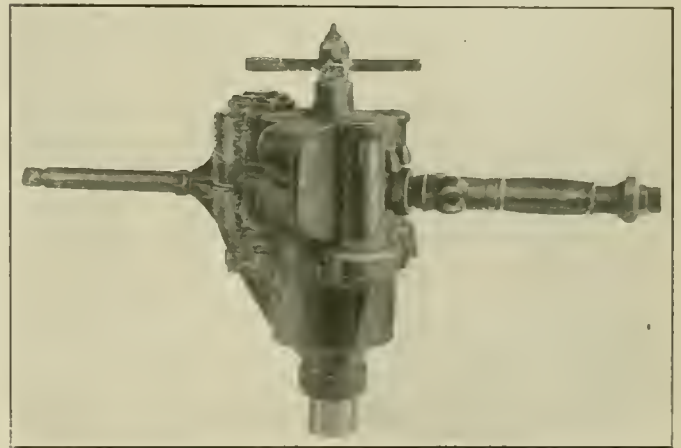

Heavy Duty Compound-Geared Drill Motor

In setting locomotive valves this motor has the same advantage in that it will revolve the drivers in either direction with equal facility.

The motor has the one piece, gear timed valves, the ball and roller bearing crank shaft and connecting rods, and is generally similar in construction to the other pneumatic drills built by the same manufacturer. It is ordinarily furnished with a No. 5 Morse taper socket and operates at a free spindle speed of 100 r.p.m.

**OXYGEN TESTS.**—The only positive way to test the comparative value of electrolytic and liquefaction oxygen is by a practical laboratory test using a gas-bell and meter, cutting metals that are identical and using the same torch for all tests. This will give the relative oxidizing effects pressure and costs.—*The Welding Engineer*.

**BOILER TUBES SPLIT IN BEADING.**—When tube ends become split from beading they may not have been properly annealed, the beading may not have been done gradually around the tube, or before any beading was done the tube ends may have projected too far beyond the tube sheet to be turned over without splitting.—*Power*.

# Railway Mechanical Engineer

(Formerly the RAILWAY AGE GAZETTE, MECHANICAL EDITION with which the AMERICAN ENGINEER was incorporated)

PUBLISHED ON THE FIRST THURSDAY OF EVERY MONTH BY THE SIMMONS-BOARDMAN PUBLISHING COMPANY

EDWARD A. SIMMONS, *President* L. B. SHERMAN, *Vice-President*  
HENRY LEE, *Vice-President and Treasurer* M. H. WIUM, *Secretary*  
WOOLWORTH BUILDING, NEW YORK, N. Y.

Chicago: Transportation Bldg. Cleveland: Citizens' Bldg.  
London: Queen Anne's Chambers, Westminster.

ROY V. WRIGHT, *Editor*  
A. C. LOUDON, *Managing Editor*  
R. E. THAYER, *Associate Editor* C. B. PECK, *Associate Editor*

Entered at the Post Office at New York, N. Y., as mail matter of the second class.

Subscriptions, including the eight daily editions of the *Railway Age Gazette* published in June in connection with the annual conventions of the Master Car Builders' and American Railway Master Mechanics' Associations, payable in advance and postage free: United States, Canada and Mexico, \$2.00 a year; Foreign Countries (excepting daily editions), \$3.00 a year; Single Copy, 20 cents.

WE GUARANTEE, that of this issue 8,300 copies were printed; that of these 8,300 copies 7,238 were mailed to regular paid subscribers, 125 were provided for counter and news companies' sales, 391 were mailed to advertisers, exchanges and correspondents, and 546 were provided for new subscriptions, samples, copies lost in the mail and office use; that the total copies printed this year to date were 31,700, an average of 7,925 copies a month.

The RAILWAY MECHANICAL ENGINEER, and all other Simmons-Boardman publications are members of the Audit Bureau of Circulations.

VOLUME 90 APRIL, 1916 NUMBER 4

## CONTENTS

<b>EDITORIALS:</b>	
How Can the Car Designer Improve?.....	165
What Is Heat-Treated Steel.....	165
The Apprentice Competition.....	165
Shop Improvement Committee.....	165
Reducing Weight in Car Design.....	165
Lost Motion in the Roundhouse.....	166
Developing the Apprentice.....	166
Costs Needed in Reclamation Work.....	166
The Expense of Poor Repair Facilities.....	166
Constructive Methods in Re-organization.....	167
Periodical Appropriations for Material.....	167
New Books .....	167
<b>COMMUNICATIONS:</b>	
The Mechanical Department Clerk.....	168
<b>GENERAL:</b>	
Scrap; Human or Material?.....	169
Diameter of Driving Axle Journals.....	171
The Locomotive Inspection Rules.....	175
Chattering Wheel Slip in Electric Locomotives.....	178
The Prevention of Spontaneous Combustion of Coal.....	179
Fuel Economy on the Rock Island.....	180
<b>CAR DEPARTMENT:</b>	
Qualifications and Training of Car Inspectors.....	181
Tables for Determining the Moment of Inertia of Rectangles.....	184
Foreign Car Repairs and Billing.....	185
Design of Passenger Equipment.....	189
Comparison of All Steel and Composite Coach Construction.....	191
Steel Box Cars on the Pennsylvania.....	193
Service of Norfolk & Western 90-Ton Cars.....	194
<b>SHOP PRACTICE:</b>	
Brake Beam Straightening Press.....	195
Patching Boilers .....	196
The Voice of the Apprentice.....	197
A Record Cylinder Weld.....	199
High Speed Steel Tipped Lathe Tools.....	200
Progress in Electric Arc Welding.....	204
Chisels .....	204

Operating a Large Engine Terminal.....	205
Reclaiming Driving Boxes.....	206
<b>NEW DEVICES:</b>	
Universal Non-Packing Valve.....	207
Machine for Grinding Reflex Water Glasses.....	207
Boring Bar for Cylinder and Valve Chamber Bushings.....	208
Chuck for Driving Taps.....	208
Moore Type Refrigerator and Heater Car.....	208
Lubricator for Locomotive Air Pumps.....	210
Compound-Geared Pneumatic Drill.....	211
<b>NEWS DEPARTMENT:</b>	
Notes .....	212
Meetings and Conventions.....	213
Personals .....	214
Supply Trade Notes.....	216
Catalogues .....	217

## NEWS DEPARTMENT

### CORRECTION

In the article on the design of Hollow crank pins in the February number, there was an error in equation (6), on page 67. This equation should read  $D_o = 8 \sqrt[3]{\frac{P^3 L^3}{15 \pi S}}$  where S is the allowable fiber stress of the material. As the formula is printed s is the stroke used in finding P. The same error occurs directly below, where the formula should read,  $D_s = \frac{\sqrt[3]{32 PL}}{\pi S}$ .

### JOHN SCOTT LEGACY MEDAL AWARDED TO CLEMENT F. STREET

The city of Philadelphia, acting on the recommendation of the Franklin Institute, has awarded the John Scott Legacy Medal and Premium to Clement F. Street, vice-president of the Locomotive Stoker Company, for the Street locomotive stoker. About 100 years ago John Scott, a chemist and metallurgist of Edinburgh, left to Philadelphia a large sum of money, the interest on which is used for the encouragement of "ingenious men and women who make useful inventions." The legacy also provides for the distribution of a medal inscribed "To the Most Deserving," and a money premium to persons whose inventions shall merit it.



Clement F. Street

Mr. Street was at one time mechanical editor and manager of the Railway and Engineering Review, now the Railway Review. He was later associated with the Dayton Malleable Iron Company for nine years, engaging in the designing and selling of railway supplies; with the Wellman, Seaver, Morgan Company, and the Westinghouse Electric & Manufacturing Company. He began development work on the stoker that bears his name in November, 1907, the first machine being put in service on a Lake Shore & Michigan Southern locomotive in May, 1909. There are now 1,000 Street stokers in service and on order.

In accepting the award of the Medal and Premium, Mr. Street expressed his high appreciation of the honor which had been conferred upon him by the Franklin Institute. He took occasion to give full credit to his assistants who had helped him perfect the stoker. He also made the statement that Herman H. Westinghouse, president of the Westinghouse Air Brake Company, was the man who really made the Street stoker a success, and added that had it not been for the financial backing which he secured and, equally important, the moral support he gave it and the men who were developing it, the machine would not be where it is today.

**EQUIPMENT ORDERS IN MARCH**

The heavy buying of cars and locomotives continued during the month of March. The sales during the last week of the month were especially large, orders having been reported during the week for 128 locomotives, 4,250 freight cars and 98 passenger cars. Orders so far reported this year to date compare with orders during the same period of 1915 as follows: Locomotives, 1,137 as compared with 181 in 1915; freight cars, 38,189 as against 8,943, and passenger cars, 535 as compared with 696. The orders for March were as follows:

	Locomotives	Freight Cars	Passenger Cars
Domestic .....	368	9,050	146
Foreign .....	41	75	24
	409	9,125	170

The important locomotive orders included the following:

Road	No.	Type	Builder
Atlantic Coast Line.....	10	Pacific	Baldwin
	2	Switch	Baldwin
Chicago & North Western.....	28	Switch	American
	14	Pacific	American
	35	Mikado	American
Great Northern .....	25	Mikado	Baldwin
Missouri Pacific .....	20	Mikado	American
	6	Switch	American
Pennsylvania Lines West.....	25	Mikado	Lima
	25	Mikado	Baldwin
St. Louis & San Francisco.....	30	Santa Fe	Baldwin
Central of Brazil .....	15	Consolidation	American
	3	Mallet	American
Java State Railways.....	8	Mallet	American

The freight car orders included the following:

Road	No.	Type	Builder
Atlantic Coast Line.....	500	Box	Barney & Smith
	300	Flat	Barney & Smith
Chicago, Burlington & Quincy...	500	Automobile	Amer. Car & Fdy.
Erie .....	1,000	Dump	Standard Steel
Great Northern .....	500	Refrigerator	Haskell & Barker
New York Central.....	1,000	Box	Amer. Car & Fdy.
	1,000	Cool	Standard Steel
Philadelphia & Reading.....	500	Hopper	Standard Steel
	500	Hopper	Pressed Steel
Southern .....	1,000	Gondola	Pressed Steel
	500	Gondola	Mount Vernon
Union Tank Line.....	750	Tank	Amer. Car & Fdy.

Nearly all the passenger cars ordered were included in two orders, those for the Atlantic Coast Line and the Illinois Central, respectively. The Atlantic Coast Line order was for 22 cars placed with the Pullman Company, including 6 baggage, 4 baggage and mail and 2 passenger and baggage cars and 10 coaches. The Illinois Central order included 1 postal and 9 mail and baggage cars ordered from the American Car & Foundry Company, and 18 baggage, 45 coaches, 10 dining, 4 buffet and 7 chair cars ordered from the Pullman Company. The foreign order for 24 passenger cars, the first large order for passenger cars for export re-

ported for some time, was for passenger train cars for the Chilean State Railways ordered from the Osgood-Bradley Car Company.

**MEETINGS AND CONVENTIONS**

*American Railroad Master Timmers', Coppersmiths' and Pipefitters' Association.*—The fourth annual convention of the Railroad Master Timmers', Coppersmiths' and Pipefitters' Association will be held at the Hotel Sherman, Chicago, on May 22-24.

*International Railway General Foremen's Association.*—The annual convention of the International Railway General Foremen's Association will be held on August 29-September 1, at the Hotel Sherman, Chicago. The following is the list of topics to be considered at this meeting: Car Department Problems, E. E. Griest, chairman; Counterbalancing the Locomotive and Fitting Up Frames and Binders, H. C. Warner, chairman; Classification of Repairs, Robert Wilson, chairman; Relation of the Foreman to the Men, T. E. Freeman, chairman.

*Master Blacksmiths' Association.*—The twenty-fourth annual convention of the International Railroad Master Blacksmiths' Association will be held at the Hotel Sherman, Chicago, August 15-17, 1916. The following subjects will be discussed: Frame Making and Repairing, Drop Forgings, Tools and Formers, Spring Making and Repairing, Frogs and Crossings, Carbon and High Speed Steels, Case Hardening, Oxy-Acetylene and Electric Welding, Shop Kinks, Heat Treatment of Metals, Piece Work and Other Methods, Reclaiming of Scrap Material, Flue Welding.

*Railway Storekeepers' Association.*—The thirteenth annual convention of the Railway Storekeepers' Association will be held on May 15-17, at the Hotel Statler, Detroit, Mich. The following subjects will be discussed: Dismantling of Cars; Standard Push Poles, Tool Handles, Jack Handles, Brake Clubs, etc.; Handling of Company Material, L. C. L. or otherwise, to Conserve Use of Cars; Filing Correspondence; Recommended Practices; Accounting; Piece Work; Standardization of Tinware: Stationery; Lumber; Ties; Rails; Scrap and Scrap Classification; Standard Buildings and Structures; Book of Standard Rules; Marking of Couplers and Parts; Reclamation.

*Master Car & Locomotive Painters' Association.*—The next annual convention of the Master Car and Locomotive Painters' Association will be held at Atlantic City, N. J., on September 12-14, 1916. The list of subjects to be presented is as follows: The Initial Treatment and Maintenance of Steel Passenger Equipment Roofs, etc.; Headlinings Painted White or in Very Light Shades—How Should They Be Treated and Should They Be Varnished; Is It Economy to Purchase Paints Made on Railroad Specifications; The Shopping of Passenger Cars for Classified Repairs; Railway Legislation and Its Effect on Business. The following questions will also be discussed: To what extent is it necessary to remove trimmings from passenger car equipment undergoing paint shop treatment? How

**RAILROAD CLUB MEETINGS**

Club.	Next Meeting	Title of Paper	Author	Secretary	Address
Canadian .....	Apr. 11	The Railways of India.....	S. J. Sarjant ....	James Powell .....	St. Lambert, Que.
Central .....	May 11	.....	.....	Harry D. Vought... ..	95 Liberty St., New York
Cincinnati .....	May 9	.....	.....	H. Boutet .....	101 Carew Bldg., Cincinnati, O.
New England .....	Apr. 11	Preparedness .....	I. A. Droegge.....	Wm. Cade, Jr.....	683 Atlantic Ave., Boston, Mass.
New York .....	Apr. 21	Passenger Car Sanitation .....	Thos. R. Crowder ..	Harry D. Vought... ..	95 Liberty St., New York
Pittsburgh .....	Apr. 21	Locomotive Inspection Laws and Rules.	F. McManamy....	J. B. Anderson....	207 Penn Station, Pittsburgh, Pa.
Richmond .....	Apr. 10	Efficiency and the Supply Department...	H. C. Pearce.....	F. O. Robinson....	C. & O. Ry., Richmond, Va.
St. Louis .....	Apr. 14	.....	.....	B. W. Frauenthal..	Union Station, St. Louis, Mo.
South'n & S'w'rn .....	Apr. 20	.....	.....	A. J. Merrill.....	Box 1205, Atlanta, Ga.
Western .....	Apr. 18	.....	.....	Jos. W. Taylor.....	1112 Karpen Bldg., Chicago.

does the hot water and oil method of cleaning locomotives at roundhouses affect the painted parts? Is there any advantage in painting or oiling the interior of new or old steel gondola and hopper cars? Is there anything superior to varnish remover for removing paint from a steel passenger car, considering labor and material costs? Is there anything superior to soap for the cleaning of passenger equipment cars preparatory to painting and varnishing?

*Central Railway Club.*—The principal speaker at the annual dinner of the Central Railway Club held at the Hotel Statler, Buffalo, N. Y., Thursday evening, March 9, was John J. McInerney, of Rochester, general counsel of the New York State Motor Federation. Mr. McInerney spoke on "Preparedness of Men to Enter the Railroad Service and the Possibilities of Advancement in the Service." He maintained that railway men were not properly "prepared," that no one of our great colleges trained men for practical railway service, and that, in consequence, there was clearly need for training schools or colleges for railway men.

The other speakers were W. L. Conwell, assistant to the president of the Safety Car Heating & Lighting Company, and John D. Wells, editor of the Buffalo News. Frank Hedley, vice-president and general manager of the Interborough Rapid Transit Company, of New York, was toastmaster.

One of the features of the evening was the testimonial accorded Harry Vought who, for 25 years, has held an official relationship with the club, two years as assistant secretary and treasurer and 23 as secretary and treasurer. Mr. Vought was presented with a purse of gold and was later arraigned on an indictment offered by B. A. Hegeman, Jr., president of the United States Metal & Manufacturing Company, and D. W. Pye, president of the Transportation Utilities Company. He had to plead to a long list of charges, after which Toastmaster Hedley, as judge, passed judgment upon his case and presented him with a roll of bank notes on behalf of the New York delegation.

The dinner was considered the most successful yet held. There were 265 ladies and gentlemen present, of which 67 were from New York, 47 of the New York delegation having come to Buffalo on three special cars.

The following list gives names of secretaries, dates of next or regular meetings and places of meeting of mechanical associations:

AIR BRAKE ASSOCIATION.—F. M. Nellis, Room 3014, 165 Broadway, New York City. Convention, May 2-5, 1916, Hotel Ansley, Atlanta, Ga.

AMERICAN RAILROAD MASTER TINNERS', COPPERSMITHS' AND PIPEFITTERS' ASSOCIATION.—W. E. Jones, C. & N. W., 3814 Fulton St., Chicago. Convention, May 22-24, Hotel Sherman, Chicago.

AMERICAN RAILWAY MASTER MECHANICS' ASSOCIATION.—J. W. Taylor, Karpen Building, Chicago. Convention, June 19, 1916, Atlantic City, N. J.

AMERICAN RAILWAY TOOL FOREMEN'S ASSOCIATION.—Owen D. Kinsey, Illinois Central, Chicago. Convention, August 24-26, 1916.

AMERICAN SOCIETY FOR TESTING MATERIALS.—Prof. E. Marburg, University of Pennsylvania, Philadelphia, Pa. Convention, June 27-July 1, Traymore Hotel, Atlantic City, N. J.

AMERICAN SOCIETY OF MECHANICAL ENGINEERS.—Calvin W. Rice, 29 W. Thirty-ninth St., New York.

ASSOCIATION OF RAILWAY ELECTRICAL ENGINEERS.—Joseph A. Andreucetti, C. & N. W., Room 411, C. & N. W. Station, Chicago.

CAR FOREMEN'S ASSOCIATION OF CHICAGO.—Aaron Kline, 841 Lawlor Ave., Chicago. Second Monday in month, except July and August, Hotel La Salle, Chicago.

CHIEF INTERCHANGE CAR INSPECTORS' AND CAR FOREMEN'S ASSOCIATION.—W. R. McMunn, New York Central, Albany, N. Y. Convention, October 3-5, Indianapolis, Ind.

INTERNATIONAL RAILWAY FUEL ASSOCIATION.—J. G. Crawford, 547 W. Jackson Blvd., Chicago. Convention, May 15-18, Hotel Sherman, Chicago.

INTERNATIONAL RAILWAY GENERAL FOREMEN'S ASSOCIATION.—William Hall, 1126 W. Broadway, Winona, Minn. Convention, August 29-31, 1916, Hotel Sherman, Chicago.

INTERNATIONAL RAILROAD MASTER BLACKSMITHS' ASSOCIATION.—A. I. Woodworth, Lima, Ohio. Convention, August 15, 1916, Hotel Sherman, Chicago.

MASTER BOILER MAKERS' ASSOCIATION.—Harry D. Vought, 95 Liberty St., New York. Convention, May 23-26, 1916, Hollenden Hotel, Cleveland, Ohio.

MASTER CAR BUILDERS' ASSOCIATION.—J. W. Taylor, Karpen Building, Chicago. Convention, June 14, 1916, Atlantic City, N. J.

MASTER CAR AND LOCOMOTIVE PAINTERS' ASSOCIATION OF U. S. AND CANADA.—A. P. Dane, B. & M., Reading, Mass. Convention, September 12-14, 1916, "The Breakers," Atlantic City, N. J.

NIAGARA FRONTIER CAR MEN'S ASSOCIATION.—E. Frankenberger, 623 Brisbane Building, Buffalo, N. Y. Meetings monthly.

RAILWAY STOREKEEPERS' ASSOCIATION.—J. P. Murphy, Box C, Collinwood, Ohio. Convention, May 15-17, 1916, Hotel Statler, Detroit, Mich.

TRAVELING ENGINEERS' ASSOCIATION.—W. O. Thompson, N. Y. C. R. R., Cleveland, Ohio. Convention, September, 1916, Chicago.

## PERSONAL

### GENERAL

ELMER A. BORELL, general air brake inspector of the Philadelphia & Reading, has been appointed engineer of motive power, with office at Reading, Pa., and the position of general air brake inspector has been abolished.

JOHN P. RISQUE has been appointed mechanical engineer of the United Railways of Havana at Cienaga, Havana. Mr. Risque was born in 1880 at Silver City, New Mexico.



John P. Risque

After finishing a manual training course at Washington University, St. Louis, Mo., in 1897, he joined the staff of the *Railway Age* in Chicago, Ill. In 1899 he entered the shops of the Atchison, Topeka & Santa Fe at Topeka, Kan., as a machinist apprentice, and in 1903 went to the Mexican Central as a machinist at Mexico City, where he later became general foreman of the main shops at Aguas Calientes. He left the Mexican Central in 1905 to accept a position with the Minne-

apolis, St. Paul & Sault Ste. Marie at Minneapolis, Minn., leaving there in 1907 to go into the manufacturing business for himself. He remained in this work until recently, when he again entered the railway field as mechanical engineer of the United Railways of Havana.

PHILIP H. CONNIFF, whose appointment as assistant superintendent of motive power and machinery of the Florida East Coast, with headquarters at St. Augustine, Fla.,

has already been announced in these columns, was born on April 10, 1871, in Trumbull County, O., and was educated in the public schools of Allegheny County, Pa. In April, 1891, he entered the service of the Pittsburgh & Lake Erie at McKees Rocks, Pa., and left that road in 1896, to go to the Pennsylvania Lines West as a machinist at the Allegheny, Pa., shops. He was promoted in 1898, to assistant roundhouse foreman and in 1900 was transferred to Ash-



P. H. Conniff

tabula as general foreman. The following year he returned to the Allegheny shops as general roundhouse foreman. In January, 1902, he entered the service of the Baltimore & Ohio as general foreman at Lorain, Ohio, and in 1906, was promoted to master mechanic of the Wheeling division. He was trans-



ferred to the Washington Terminal Company in charge of the locomotive department in 1908, and was appointed master mechanic of the Connellsville division of the Baltimore & Ohio in 1910. The following year he was appointed master mechanic of the Cumberland division of the same road. In June, 1912, he was transferred to Baltimore, Md., as superintendent of the locomotive and car departments at the Mt. Clare shops, and left the service of that road in January of this year to go to the Florida East Coast as assistant superintendent of motive power and machinery as above noted.

H. J. WARTHEN, master mechanic of the Richmond, Fredericksburg & Potomac at Richmond, Va., has been appointed superintendent of motive power, succeeding W. F. Kapp, resigned. Mr. Warthen will continue to perform the duties of master mechanic at Potomac yard.

#### MASTER MECHANICS AND ROAD FOREMEN OF ENGINES

A. BROWN, locomotive foreman of the Canadian Pacific at Ft. William, Ont., has been promoted to district master mechanic at Winnipeg, Man., succeeding A. Peers, transferred.

J. L. BRUMMEL has been appointed road foreman of engines of the Minneapolis & St. Louis at Monmouth, Ill.

T. W. COE, superintendent of shops of the New York Central west of Buffalo, at Elkhart, Ind., has been appointed master mechanic of the Indiana Harbor Belt, with headquarters at Gibson, Ind., in charge of the machinery and car departments.

B. B. EIDSON, formerly road foreman of locomotives of the Grand Trunk at Smithers, B. C., has been appointed road foreman of locomotives at Regina, Sask.

W. B. EMBURY, master mechanic of the Chicago, Rock Island & Pacific at Valley Junction, Iowa, has been transferred to Estherville, Iowa, succeeding W. T. Fitzgerald.

W. T. FITZGERALD, master mechanic of the Chicago, Rock Island & Pacific at Estherville, Iowa, has been transferred to Manly, Iowa.

WM. GEMLO has been appointed road foreman of engines of the Minneapolis & St. Louis at Watertown, South Dakota.

R. HAYLOR has been appointed road foreman of engines of the Minneapolis & St. Louis at Fort Dodge, Iowa.

R. C. HYDE, master mechanic of the Chicago, Rock Island & Pacific at Manly, Iowa, has been transferred to Valley Junction, Iowa.

M. F. McCARRA has been appointed master mechanic of the Illinois Southern, with office at Sparta, Ill., succeeding G. A. Gallagher, deceased.

P. C. MOSHISKY, joint foreman of the Denver & Rio Grande at Durango, Col., has been appointed master mechanic, with headquarters at Ridgway, Col., succeeding J. A. Edwards, resigned.

A. PEERS has been appointed district master mechanic, district 2, Saskatchewan Division of the Canadian Pacific at Moose Jaw, Sask., succeeding J. Neill.

W. J. RENIX, heretofore district master mechanic of the Canadian Pacific at Calgary, Alta., has been appointed district master mechanic, district 1, British Columbia division, at Revelstoke, B. C., succeeding L. Fisher, assigned to other duties.

A. J. ROBERTS, formerly locomotive foreman of the National Transcontinental at Transcona, Man., has been appointed district master mechanic, district 2, at that place, succeeding A. Devine.

J. P. STOW, JR., has been appointed master mechanic of the New London division of the New York, New Haven & Hartford, with headquarters at Midway, Conn.

S. WEST, formerly district master mechanic of the Canadian Pacific at Kenora, Ont., has been appointed district master mechanic at Medicine Hat, Alta., succeeding R. Brown, who has received a commission as lieutenant for overseas service.

JAMES B. WYLER has been appointed master mechanic of the Midland division of the New York, New Haven & Hartford at Boston, Mass.

#### CAR DEPARTMENT

W. JONES has been appointed assistant foreman in charge of freight car repair yards of the National Transcontinental at Transcona, Man.

W. MILLS has been appointed car foreman in charge of all work at Transcona yards of the National Transcontinental at Transcona, Man.

C. A. MUNRO, formerly car foreman of the Grand Trunk at Edson, Alta., has been appointed car foreman at Melville, Sask., succeeding W. Mills, resigned.

B. WOODCOCK, formerly car inspector of the Grand Trunk at Melville, Sask., has been appointed car foreman at Edson, Alta., succeeding C. A. Munro, transferred.

#### SHOP AND ENGINE HOUSE

GEORGE W. ARMSTRONG, assistant shop superintendent for the Erie at Susquehanna, Pa., has been promoted to superintendent of the central manufacturing plant at Meadville, Pa.

P. S. BEATT, formerly locomotive foreman of the Canadian Pacific at Coronation, Alta., has been appointed locomotive foreman at Ogden, Alta.

A. W. CLARK, formerly locomotive foreman of the Canadian Pacific at Kamloops, B. C., has been appointed locomotive foreman, Brandon, Man., succeeding G. Twist, transferred.

G. CLISSOLD, formerly night locomotive foreman of the Canadian Northern, has been appointed assistant foreman at Rainy River, Ont., succeeding E. R. Mills, promoted.

J. N. DUNCANSON, formerly assistant locomotive foreman of the Canadian Northern at Winnipeg, Man., has been appointed locomotive foreman at Dauphin, Man., succeeding J. W. Skinner.

H. HERICK has been appointed locomotive foreman of the Canadian Pacific at Coronation, Alta., succeeding P. S. Beatt, transferred.

R. N. MILLICE has been appointed assistant locomotive superintendent of the United Railways of Havana at Cienega, Havana. Mr. Millice gained his first experience in his father's machine shop at Topeka, Kan., and afterwards spent four years in the shops of the Santa Fe at that place. In 1900 he went to the Mexican Central, working successively as draftsman, efficiency expert, general foreman and master mechanic. He went to the Mexican Railroad Company in 1909 at Orizaba, where he remained until 1911, when he left the railway field.

E. R. MILLS, formerly assistant foreman of the Canadian Northern at Rainy River, Ont., has been appointed locomotive foreman at Dauphin, Man., succeeding J. Duncanson.

C. H. MOULTON, formerly acting road foreman of locomotives, district 3, of the National Transcontinental at Redditt, Ont., has been appointed locomotive foreman at Transcona, Man., succeeding A. J. Roberts promoted, and his former position has been abolished.

B. T. PATTERSON, formerly machinist of the Canadian Northern, has been appointed night locomotive foreman at Rainy River, Ont., succeeding G. Clissold, promoted.

E. A. PETTIT has been appointed general foreman of the locomotive shops of the New York Central West at Elkhart, Ind., succeeding H. E. Warner, promoted.

W. SHEPHERD has been appointed locomotive foreman of the Canadian Northern at Portage la Prairie, Man., succeeding S. Hicks.

W. F. SMALLWOOD has been appointed locomotive foreman, temporarily, of the Intercolonial Railway, at Newcastle, N. B., a new position.

G. TWIST, formerly locomotive foreman of the Canadian Pacific at Brandon, Man., has been appointed locomotive foreman, Fort William, Ont., succeeding A. Brown, promoted.

H. E. WARNER has been appointed superintendent of shops of the New York Central West, at Elkhart, Ind. He was born on March 2, 1872, and was educated in the grammar schools of Elkhart and took a course of mechanical engineering in the International Correspondence Schools. He began his railway work as an apprentice on the Lake Shore & Michigan Southern, at Elkhart on May 7, 1888. Later he was a machinist at Elkhart and at various contract shops throughout the country. He later returned to Elkhart as a machinist and was appointed piece work inspector in 1904. Since that time he has held the positions of shop inspector and general foreman, being appointed to his present position on March 1, 1916.

J. J. WENZEL, formerly assistant roundhouse foreman of the New York Central West at Air Line Junction, Ohio, has been appointed erecting shop foreman at Elkhart, Ind., succeeding E. J. Pettit, promoted.

W. H. WORTMAN, formerly general foreman of the Canadian Pacific at Ogden, Alta., has been appointed locomotive foreman at Calgary, Alta., succeeding J. Neill, transferred.

#### OBITUARY

WILLIAM H. ELLIOTT, formerly fuel agent of the New York, New Haven & Hartford, died on March 2, at his home in New Haven, Conn., at the age of 63.

CHARLES F. ROBERTS, assistant locomotive superintendent of the United Railways of Havana, died on March 8 at his home in Cienaga. Mr. Roberts was born in Wilkes-Barre, Pa., 38 years ago, and served on railways in the United States, Mexico and Ecuador before going to Cuba.

G. A. GALLAGHER, master mechanic at the Illinois Southern at Sparta, Ill., died in that city on February 24 of pneumonia.

ROBERTS LAWRIE STEWART, mechanical superintendent of the Second district of the Chicago, Rock Island & Pacific at El Reno, Okla., died suddenly at Kansas City, Mo., on March 24, at the age of 50. He was born March 22, 1866, at Tyrone, Pa., and was educated in the public schools and at Cornell University. He entered the service of the Denver & Rio Grande in 1885 as machinist apprentice and after completing his course was appointed roundhouse foreman, leaving that road in 1905. He was employed later by the Atchison, Topeka & Santa Fe, the Kansas City Southern and the Chicago, Rock Island & Pacific as general foreman and master mechanic. On June 1, 1914, he was promoted to mechanical superintendent of the Third district of the Chicago, Rock Island & Pacific at El Reno, Okla., and on January 1, 1916, his jurisdiction was extended to cover a portion of the old Second district when it was consolidated with the First and Third districts. Mr. Stewart was in active service up to the time of his death.

## SUPPLY TRADE NOTES

W. G. Willcoxson has been appointed sales representative of the Boss Nut Company, with headquarters at Chicago, Ill.

Edwin H. Baker, second vice-president of the Galena Signal Oil Company, has retired from that position after having been engaged in the manufacture and supply of lubricating oils for 43 years.

Charles Morgan Hewitt, chairman of the board of directors of the Magnus Company, Inc., and president of the Hewitt Company, both of Chicago, died at Palm Beach, Fla., on March 16, after a prolonged illness.

The Sherritt & Stoer Company, Inc., 603 Finance building, Philadelphia, Pa., has been appointed exclusive sales agents in the Philadelphia district for the Beaudry Champion and Peerless power hammers made by Beaudry & Co., Inc., Boston, Mass.

Frank G. Wallace, of Pittsburgh, Pa., for many years a director of the Canadian Locomotive Company, Ltd., Kingston, Ont., has been appointed managing director of that company, and William Casey, hitherto assistant general manager, has been appointed manager.

H. A. Gray has been appointed assistant manager railroad sales of Joseph T. Ryerson & Son, with jurisdiction over Eastern railroad and machinery sales, with headquarters at New York. All branches of the sales and operating departments will be directed as heretofore, from Chicago.

L. E. Jordon, president and general manager of the Vulcan Process Company, Inc., Minneapolis, Minn., has disposed of his interest in the company and has been succeeded in office by Clifford N. Lockwood, who will have the position of treasurer and general manager. The Vulcan Process Company, Inc., deals in oxy-acetylene apparatus and supplies.

George E. Fox, formerly southeastern representative of the Curtain Supply Company, has been appointed western sales agent of the same company, with headquarters in Chicago. T. P. O'Brien has been appointed southeastern sales agent, with headquarters at New York City. Mr. O'Brien has been with the O. M. Edwards Company of Syracuse, N. Y., for a number of years.

Ralph G. Coburn, for the last few years eastern sales manager of the Franklin Railway Supply Company, has been appointed sales manager of the electrical department of that company, now handling the Stone-Franklin lighting equipment. Mr. Coburn has been with the Franklin Railway Supply Company for the past seven years, and was at one time in charge of its Chicago office. His headquarters will be in New York.

The Quigley Furnace & Foundry Company, Springfield, Mass., having recently added to its business a brass rolling mill department for the production of flat brass, the stockholders of the company, at the annual meeting on January 26, decided to adopt a new and more comprehensive name, the Metals Production Equipment Company. No change has been made in general policy or management. The furnace, foundry and powdered coal departments will be continued as heretofore.

Holden & White is the name of a new firm formed by R. R. Holden, formerly with the Wesco Supply Company, of St. Louis, Mo., and recently a manufacturer's agent in Chicago, and W. McK. White, former sales manager of the Esterline Company, of Indianapolis, Ind. The new company will represent a number of manufacturers of railway materials and equipment, and has arranged for affiliated representation in 15 cities in the United States and Canada. The company has opened offices in the Fisher building, 343 South Dearborn street, Chicago, Ill.

H. E. Creer, who for the past five years has been associated with McCord & Co., of New York and Chicago, has resigned to become eastern sales agent for the Union Railway Equipment Company, with headquarters in the McCormick building, Chicago, Ill. B. H. Forsyth, who for three years has been a member of the sales force of the Hale & Kilburn Company, has been appointed western sales agent of the Union Railway Equipment Company, with offices in the McCormick building, Chicago. Mitchel A. Evans, formerly associated with the Railway Appliances Company, has been appointed sales agent, with headquarters in the McCormick building, Chicago.

G. H. Groce has entered upon his new duties as head of the railway department of the Electric Storage Battery Company of Philadelphia, with headquarters at Chicago. Mr. Groce was born at Tarentum, Pa., February 19, 1864. He was educated in the public schools, and in 1880 became a telegraph operator on the Pittsburgh & Lake Erie. After two years' service on that road, he was for one year an operator on the Baltimore & Ohio, and then returned to the Pittsburgh & Lake Erie as freight and ticket agent and train despatcher. From 1885 to 1897 he held positions with various roads as train despatcher, chief train despatcher and chief clerk in the general superintendent's office. In 1897 he became superintendent of telegraph of the Baltimore & Ohio Southwestern, and from 1899 to 1901 was superintendent of the Springfield division of that road. In 1902 he became southwestern agent of the Taylor Signal Company at St. Louis. He returned to railway work the following year, serving from 1903 to 1910 as superintendent of telegraph and assistant to the general manager of the Illinois Central. From 1910 to 1912 he was assistant to the president of the General Railway Signal Company, and for the following two years was vice-president of the Wright Telegraphic Typewriter Company. For the past year he has been engaged in special work for the General Railway Signal Company.

Walter H. Bentley, who has been appointed assistant to the president of Mudge & Co., Chicago, Ill., was born in Chester, England, in 1888. He came to America in 1892, and was educated in the public schools at Oak Park, Ill. In



Walter H. Bentley

1903 he entered the service of the Chicago & North Western as an employee of the storekeeping department. From 1903 to 1908 he was in the maintenance of way department of the same railroad. In 1909 he entered the employ of the Duluth & Iron Range as a locomotive fireman, returning to the North Western in December of the same year. From that time until May, 1917, he worked in various capacities in the maintenance of way department, the pension department, the superintendent's office and the purchasing department. He became a member of the Chicago sales force of the Baldwin Locomotive Works and the Standard Steel Works upon leaving the North Western. In April, 1914, he became western representative of the Curtain Supply Company, and on March 1, 1916, was appointed assistant to the president of Mudge & Company, of Chicago.

## CATALOGUES

**ELECTRIC HAMMER DRILLS.**—Bulletin E-38 issued February 1 by the Chicago Pneumatic Tool Company, describes the Duntley universal electric hammer drill manufactured by that company.

**FORGING MACHINES.**—The National Machinery Company, Tiffin, Ohio, in National Forging Machine Talk No. 8 describes the new method used in the company's heavy-pattern forging machines of alining heading slides.

**TESTING MACHINES.**—Catalogue No. 93 recently issued by the Watson-Stillman Company, Aldene, N. J., describes in detail the Sturcke-Watson-Stillman testing machine for cylindrical gas containers. The booklet describes and illustrates the machine and explains its uses and possibilities.

**TUNGSTEN MINING IN COLORADO.**—A folder bearing this title, recently issued by the Vanadium-Alloys Steel Company, Pittsburgh, Pa., contains a reprint of an article on this subject written by Roy C. McKenna, the president of the Company, which appeared in the Iron Trade Review.

**ELECTRICAL APPARATUS.**—One of the recent publications of the railway and lighting department of the Westinghouse Electric & Manufacturing Company is an illustrated booklet containing a paper presented before the Railway Club of Pittsburgh by E. M. Herr, entitled "Notes on Electric Power Development."

**MACHINE TOOLS.**—The Niles-Bement-Pond Company has recently issued four folders relative to its machine tools. Circular No. 101 illustrates and describes a 48-in. car wheel borer; circular No. 102, a center drive car wheel lathe; circular No. 103, a 36-44 in. side head boring mill, and circular No. 104 a 90-in. driving wheel lathe, heavy pattern.

**INDUSTRIAL LOCOMOTIVES.**—The Bell Locomotive Works, 30 Church street, New York, in Record No. 7, illustrates and describes its line of industrial steam locomotives burning liquid fuel. These locomotives burn fuel-oil, distillate or gasolene, etc., and have been supplied for use on sugar plantations, in tunnel construction, in industrial plants and mines, on logging railroads, and for similar purposes.

**LIGHTING AND HEATING BURNERS.**—The Alexander Milburn Company, Baltimore, Md., has recently issued a 12-page booklet describing and illustrating the Wells Light and Heating Burner. This burner, which until June, 1915, was handled by the Wells Light Manufacturing Company, Jersey City, N. J., burns kerosene oil and is adapted for contractors, railroads, industrial plants, foundries, ship yards, etc.

**REFRIGERATION, VENTILATION AND HEATING OF CARS.**—The Refrigerator, Heater & Ventilator Car Company of St. Paul, Minn., has issued a 64-page booklet explaining the Moore system of heating, cooling and ventilating cars and pointing out the economies which obtain from its use. It also contains 41 testimonials to the merits of the system received from companies which are using it in their cars.

**WIRING DEVICES.**—The Bryant Electric Company, Bridgeport, Conn., has issued an elaborate catalogue of 168 pages containing illustrations, descriptions, list prices, etc., of the company's line of Superior wiring devices. In the catalog there are illustrated "New Wrinkle" and "Wrinklet" sockets and other fixtures and various types of switches, receptacles, plugs and similar fixtures. The book is very well gotten up and profusely illustrated.

**STORAGE BATTERY CARS.**—The Railway Storage Battery Car Company, New York, has issued a booklet entitled Self-Propelled Passenger Cars. The booklet contains views and plans of cars which have been supplied for city and

suburban service. The cars are equipped with the Edison non-acid storage battery, and are supplied for both steam railroads and electric railways.

**HOISTS AND DERRICKS.**—The Minneapolis Steel & Machinery Company, Minneapolis, Minn., has published a 112-page catalogue describing its steam and electric hoisting engines, tractors, derricks, hoists and miscellaneous material used for hoisting purposes. The catalogue is fully illustrated and goes into considerable detail as to the mechanical parts of the hoists and derricks.

**FREIGHT CARS.**—The Ralston Steel Car Company, Columbus, Ohio, has recently issued a loose-leaf binder containing copies of bulletins showing cars which this company has built for various railroads and other owners of freight cars. Each bulletin illustrates one or more cars and gives a very brief description and general information relative to each car. The illustrations are extremely clear and the binder and its contents very attractively gotten up.

**FOUNDRY EQUIPMENT.**—Catalogues No. 118 and No. 119, recently issued by the Whiting Foundry Equipment Company, Harvey, Ill., deal respectively with the Whiting cupola and the company's line of air hoists. In the latter booklet the air hoists are described in detail, views being shown of the several hoists and of typical installations. The catalogue describing the Whiting cupola shows sectional and other views, and typical installations of the apparatus in connection with an explanation of the features of the cupola's design.

**CONDUIT CHART.**—The National Metal Molding Company, Pittsburgh, Pa., manufacturers of electrical conduits and fittings, is distributing an attractive wall hanger, reproducing, in one-half actual size, conduit charts as adopted and recommended by the National Electrical Contractors' Association, showing sizes of conduit required by the National Electrical Code for carrying various sizes of conductors. This hanger is printed on linen-backed stock and will prove of convenience for reference in the offices of architects, engineers and electrical contractors.

**BEARINGS.**—The Norma Company of America, New York, has recently issued catalogue No. 105 describing and illustrating and giving list prices of the Norma precision bearings made by the company. A large part of the booklet is devoted to a description of the Norma ball bearing. The various types of bearing are shown in halftone and line illustrations and the accompanying reading matter discusses the design of the bearing and its advantages for various kinds of service. A large part of the booklet is devoted to lists of bearings giving the dimensions, types and list prices.

**TIMBER FOR STRUCTURAL PURPOSES.**—The Structural Timber department of the National Lumber Manufacturers' Association, Chicago, has issued the first of a series of engineering publications on structural timber. This book of 20 pages discusses briefly the need for engineering information concerning timber. It also contains much information of value regarding the available supply of timber, its relative cost and its suitability for modern forms of mill or other construction, and serves to introduce later bulletins which will deal more specifically with the various phases of structural timber.

**STORAGE BATTERIES.**—Two of the recent publications of the Edison Storage Battery Company are entitled, respectively, "The Edison Alkaline Storage Battery" and "Edison Alkaline Storage Batteries and Some of Their Applications." The former booklet has been issued as Monograph III of the National Education Association Joint Committee Series. It describes the manufacture of the Edison batteries—and in one of its chapters takes the reader on a trip through the factory in Orange, N. J. The booklet also touches upon some of the characteristics of the battery, dealing with its chemistry,

its advantages, its approach to the ideal battery, etc. The other bulletin mentioned considers the possible use of Edison batteries and their advantages for various kinds of service. Both booklets are illustrated.

**WELDING.**—The Goldschmidt Thermit Company, 90 West street, New York, has recently issued three attractive bulletins relative to the Thermit process of welding. One is a folder, treating in a somewhat general way of the subject of locomotive repairs. The other two are much more elaborate and are entitled respectively: "Thermit Locomotive Repairs" and "Thermit Mill and Foundry Practice." These books contain instructions for the use of Thermit and are illustrated with drawings and other views showing the necessary steps to be taken. There are also a number of views showing the results which may be obtained.

**CENTRIFUGAL PUMPS.**—The Allis-Chalmers Manufacturing Company, Milwaukee, Wis., has recently issued pamphlets describing its centrifugal pumps and pumping units, and a summary of tests on a 10-in. centrifugal pump. In these tests the maximum efficiency of 85 per cent. was reported. The pamphlet describing the centrifugal pumping units shows cross section illustrations of the various types of pumps manufactured by that company, describes the construction and gives the reports of tests made with the different types. Illustrations of test plants and various pump installations are also included.

**LOCOMOTIVE DEVICES.**—The Franklin Railway Supply Company has recently issued an attractive and well illustrated booklet describing and illustrating in half-tones and line drawings the McLaughlin flexible conduit, Franklin ball joints and the Franklin single water joint. The McLaughlin flexible conduit is an all-metal connection for use between engine and tender, etc., for air, steam and oil lines. When assembled it consists of two double joints, one single joint and two lengths of extra heavy wrought iron pipe. The Franklin ball joint is intended to replace rubber hose for use in round-houses or for heating coaches in terminals or coach yards. The single water joint is designed for injector connections.

**ELECTRICAL SUPPLIES.**—The Western Electric Company's 1916 year book, which is now being distributed to the trade, contains 1,504 pages, nearly 300 pages more than the first edition of the Electrical Supply Year Book which the company published on January 1, 1915. The book contains illustrations and list prices of the extensive lines of electrical equipment which are sold by the company, and like the 1915 year book, it is characterized by list prices which are subjected with very few exceptions to a single discount for all the lines included. The Western Electric Company announced last year that it was its intention in the future to revise its catalogue yearly, and the present edition is a result of that policy.

**BOILERS.**—The Harrison Safety Boiler Works, Philadelphia, Pa., has recently issued a 68-page catalogue entitled "Finding and Stopping of Waste in Modern Boiler Rooms." The book treats of the value of feed water and condensate meters as aids in the management of power plants and it is shown how with a feed water meter one can ascertain the results of various factors, such as grade of fuel, grates, methods of firing, air leaks, control of draft, condition of gas passages, scale and soot on boiler tubes, radiation, etc. The point is made that the use of records which may be obtained with the meters arouses the ambition and spirit of emulation of the men, and makes it possible to reward special skill or attention to duty, as by bonuses or promotions. A section of the book also treats of the Cochrane metering heater (combined open feed water heater and hot water heater) with its several modifications. The Cochrane flow recorder for use in connection with V-notch weirs and a new type of meter working on the volumetric principle are also described. The book is well illustrated.

# Railway Mechanical Engineer

Volume 90

May, 1916

No. 5

## Saving Weight to Provide Boiler Capacity

A great deal has been accomplished within the past two or three years in the way of reducing the dead weight of the machinery in a locomotive by the use of special steels. That there is still more to be attained is evident when we consider the changes which would be made possible by the use of different materials in some of the locomotives now in service. Take, for example, a recent design of Santa Fe or 2-10-2 type locomotive. The substitution of alloy steel for carbon steel in the piston rods, crossheads and pins, side rods, crank pins and valve gear and the use of hollow driving axles would result in a reduction in weight of almost 5,000 lb. The use of the hollow axles alone would save in the neighborhood of 1,000 lb. The value of this saving in a direct way, aside from other considerations, will be seen when it is considered that if put into the boiler this extra weight would add fully two inches to its diameter. Looking at the matter of saving in weight from this angle shows in a very practical way the value of refinement in design in the increasing of capacity.

## The Car Terminal Competition

The first prize in the car terminal competition, which closed April 1, was awarded to R. S. Mounce, general foreman car repairs, Erie Railroad, Jersey City, N. J. The article is published in the car department section of this issue. The judges awarded the second prize to J. E. Ross, master painter of the New Orleans, Mobile & Chicago at Mobile, Ala., whose article will be published in an early issue. There were a number of other articles received in the competition, most of which are suitable for publication either in whole or in part. Mr. Mounce's article should be of general interest. It describes the practice at the Erie Railroad's terminal at Jersey City, where a very large suburban traffic is smoothly and effectively handled under conditions made difficult by the physical characteristics which have necessitated the present layout in increasing capacity. If a car terminal could be laid out under ideal conditions as regards distance from the passenger station, track room, repair facilities, etc., the problem of caring for the large number of cars which are daily cleaned and repaired at Jersey City would be a comparatively simple one. The principal value of Mr. Mounce's article lies in the fact that it describes the practice that is in daily successful operation in a terminal where the conditions are not ideal.

## Cleaning Passenger Cars

It is doubtful if the average car foreman or car cleaner fully realizes the value to his company of cars thoroughly cleaned inside and out. Many of these men do not ride in regular passenger trains to any extent and consequently they are not familiar with the attitude taken by the traveling public. The road that neglects the cleaning of passenger cars in order to save mechanical de-

partment expense is providing decidedly poor advertising for the traffic department. No other single item has as much direct effect on the passenger's opinion of a railway as the condition of its passenger equipment. This does not apply simply to the inside of the car. If the outside is dirty it produces a bad effect in the mind of the passenger before he enters the train, and he is then likely to look for and comment unfavorably on things which he might otherwise have overlooked. We have frequently called motive power men to account for being motive power men and not railroad men. This is a case where the car department has a chance to show that its employees are not simply car department men but are railroad men, who will take into consideration the work that has to be done by officers of the traffic department in creating business which may very easily be lost by laxity on the part of the car department. If a neighboring road has clean cars, no matter how nearly alike the service on the two roads may be in other respects, the road with the clean cars is likely to get more of the business than the one which neglects the matter of cleanliness.

## The Fireman and Boiler Capacity

It took locomotive designers some time to realize that a locomotive's capacity depended mainly on the boiler, but since they have realized it they have taken adequate steps to provide locomotives with ample steam making facilities. With the growth of the locomotive the size of the boiler has increased to such an extent that it has overreached the limitations of hand firing and the mechanical stoker has been a necessity in many cases. In fact, there is little question but that there are locomotives now in service from which the maximum capacity is not being obtained because of its being impossible to obtain this capacity with hand firing. This has been pointed out previously by L. R. Pomeroy in remarks made before the New York Railroad Club. An ordinary rate of evaporation for a locomotive is 10 lb. of water per square foot of heating surface per hour; this may reach 12 lb. for short intervals but the probability is that in average service not over 7 or 8 lb. is being attained. A fireman cannot be counted on to fire continuously over 5,000 lb. of coal per hour. If we consider a locomotive with 4,500 square feet of heating surface, the total evaporation per hour at the rate of 10 lb. will be 45,000. At 6 lb. of water per pound of coal, the coal necessary to produce this evaporation would be 7,500 lb. per hour, which is well above the limit for hand firing. It would seem that there are a good many cases where locomotives, both passenger and freight, are not delivering the output which was expected of them and in which the steaming qualities of the engine are blamed for the trouble when in reality the difficulty lies in the inability to obtain the full capacity by handfiring. When a locomotive is equipped with such a large boiler there should be sufficient foresight brought to bear on the subject to insure the development of all the power possible. The mechanical stoker is capable of firing coal at any rate at which the present day firebox can burn it

and if large locomotives are required to obtain maximum train loads it is no economy to hand fire them if by doing so their full capacity cannot be attained.

**Specializing  
Enginehouse  
Work**

Many of our contributors on engine house subjects lay considerable stress on the value of having specialists for the different classes of work in the enginehouse. There can be little doubt as to the value of organizing an enginehouse force in this way, particularly if the terminal is a large one. The man, or gang of men, who attends to nothing but electric headlight repairs very soon becomes expert in the determination of what is wrong with this equipment and what should be done to remedy it. Air brake work has long been specialized and it is probable that the desirability or even necessity of having experts in air brake work led to the extension of the practice as terminals increased in size and the locomotives became more complicated. One class of work that should be taken care of by specialists wherever possible is the reducing and fitting of main rod brasses. If this work is assigned to men who do nothing else except in cases of emergency they become so expert that it will be found that trouble from heating at either end of the rod will be greatly reduced, if it is not entirely eliminated. While the practice of specializing the work is not so readily carried out in the small engine house it is possible even there to obtain very satisfactory results by assigning to one man two or three lines of work that are closely allied. Of course, the men who are assigned to special work should be good all-round mechanics in the first place, but by careful selection of the men and due consideration of the class of work for which they are best fitted, better results can be obtained in almost any engine terminal by specializing the work than by the indiscriminate assignment of all the mechanics to all classes of work.

**England's Idea  
of the Steel  
Passenger Car**

From the experience the railroads have had in this country with the public demand for all-steel passenger cars, it is hard to understand that the English people can have the objections to this type of equipment as expressed recently in *The Engineer* of London. That publication states:

"The all-steel vehicle is an unsatisfactory ideal. It is difficult to construct, is not easily decorated and is very susceptible to climatic changes. Steel coaches are understood to resist better the evils of collision and derailments, but they are not without objections that are not found in wooden stock. One does not relish the idea, for instance, of having to be rescued from an all-steel car by an oxy-acetylene blowpipe cutting the sides of the carriage open. The rendering of wood non-inflammable is a better idea, etc."

First, *The Engineer* calls attention to the difficulties met in the decoration of the steel cars. Notwithstanding these difficulties, however, the American railroads are today producing steel cars as handsome, we venture to say, as any of the wooden cars in use in England. Their susceptibility to climatic changes has been amply taken care of by our insulating engineers. The item referred to passes over lightly the advantages the steel car has in collisions and derailments, indicating that it is far more desirable to be rescued from a wreck by means of a hatchet than the oxy-acetylene blowpipe. Our English contemporary evidently forgets the fact that the need for rescue has been very materially reduced by the adoption of steel equipment, and further, that this steel equipment is so carefully designed that, even in the case of accident, seldom, if ever, will the oxy-acetylene blowpipe be found necessary to rescue passengers. We are satisfied with the steel equipment. We know it is a good thing. Our

engineers have met the problems raised by the introduction of this equipment in an able manner. That the English public, and especially the English engineers, are not in accord with the idea of steel cars is possibly due to the fact that the designs of and methods of constructing our steel equipment have not been as carefully studied and analyzed as they might have been.

**Altering  
Locomotive Front  
Ends**

When a locomotive is reported as not steaming the first move made in the roundhouse is to examine the front end and if there are no leaks or other plain indications of the cause of the trouble either the nozzle is reduced or the diaphragm shifted. It is well known where such indiscriminate "fooling" with front ends leads. There are many roads on which it is doubtful if two locomotives of the same class have the same front end arrangement; the locomotives have been changed in one way at one terminal and in another way at another terminal. A bridge is put in the nozzle at one engine house and is taken out and the diaphragm shifted at the other end of the run. Some of the roads that have gone into an extensive program of fuel economy have found it necessary to restandardize the front end arrangement of practically all of their locomotives. There must, however, be a prohibition placed on indiscriminate front end alterations if this work is to have any effective results or if new locomotives are to develop their full effectiveness. There was a time when little or nothing was known about front end design and it may have been justifiable at that time to let every master mechanic and engine house foreman work out his own ideas regarding the drafting of locomotives, but there is now sufficient definite information available to guide the designer in determining on a front end arrangement that should result in a free steaming engine. If adjustments or alterations are afterwards found necessary they should be made under the direction of a mechanical department officer who will investigate matters deeply enough to be sure what condition needs correcting and then see that the correcting is done in a manner that will not tend to completely demoralize the standard front end arrangement of all locomotives on the system.

**Railway  
Mechanical  
Conventions**

With the month of May the various mechanical department associations begin holding their annual conventions. Some of these associations are well supported by the representatives of the different roads, while others do not have the support they are entitled to. This is not always the fault of the members of the associations, as in several instances the roads by which they are employed refuse them transportation and the time for attending the conventions. A review of the work done by the associations, especially in the past few years, should make it plain to the mechanical department officers that a large amount of good constructive work is being accomplished by these associations. Further than this, the benefits derived by the men in meeting and becoming acquainted with fellow craftsmen, and the interchange of personal experiences during the convention period, are of decided advantage to both the men and their employers. It broadens the men and fills them with new ideas and an enthusiasm which will have its good effect on the work when they return to their shops or offices. The duties and responsibilities of the minor mechanical officers are constantly increasing. The "stay-at-home" man cannot pretend to meet these conditions adequately. The men must broaden out. They must be educated, and the annual conventions offer an excellent means for this education. If the officers in authority will view the matter as one of investment and send their subordinates to conventions with instructions

to give as much as they can and absorb all that they can, the work of the associations will still further increase in value and the men and their companies will be greatly benefited.

#### The Responsibility of Car Inspectors

In writing to the editor of the Railway Age Gazette, a car foreman compares the duties of the locomotive engineer, the conductor and the car inspector. The latter is responsible to a large extent for the safety of human life and property. In the matter of responsibility his duties rank high even when compared with those of the man in charge of the operation of a locomotive and the knowledge required of him is at least as great as that possessed by the average locomotive engineer of today, even with the considerable difference in the salaries paid. But the car inspector is not always in full realization of the responsibility which rests upon him and this is a point which we do not feel has been brought out as strongly as it might be in the various discussions on the car inspector and his duties which we have published in the past few months. The foreman in charge of the inspector may have a full realization of the responsibility which rests on himself and through him on his inspector, but unless the inspector himself realizes this responsibility he will not be as effective as he should be. We have known car inspectors to deliberately neglect the repair of slight defects which they must have known were dangerous and who did not hesitate to let cars go out in such condition. If a car inspector is to live up to what is, or at least should be, expected of him, he not only should possess a very complete knowledge of everything pertaining to his work, but he should be brought to realize to the fullest extent that on him rests the responsibility for determining not simply whether a car is fit to run but whether or not it is in such a condition that it can safely carry passengers or freight.

#### Getting the Most Out of Locomotives

The longer a locomotive is kept in service the more it earns for the railway. This does not mean simply that if a locomotive is turned out of a shop at a certain time and is not returned to the shop for repairs until a month or two months after the regular shopping time it has fulfilled its duty as a contributor to the company's earnings. The locomotive may have been out of service for considerable periods during this time for heavy roundhouse repairs or it may have been a large contributor to the total of the road's engine failures, in either of which cases it is falling short of accomplishing its maximum as an earner. A locomotive should be kept in service as long as possible, provided excessive running repairs are not required in order to accomplish this, and also that this extra period of service is not purchased at the expense of a demoralization of traffic because of engine failures. The condition which should be striven for is the turning out of locomotives which have undergone general repairs in such good condition that they are capable of maximum performance without failure for the greatest length of time. Such results obtained from locomotives give the company a maximum return for the money invested in motive power and to obtain them does not necessarily require that the road expend more per engine for repairs than a neighboring road or than is spent by the average road. But it does require that the general repairs be carried out in the best manner possible and that no running repairs be neglected. Finally, the effectiveness of repair work depends very largely on the shop organization and equipment. The matter of equipment applies particularly at the present time on many roads which have added to their motive power considerable numbers of large engines which are beyond the capacity of the road's engine house and shop buildings and machine facilities. There is too little being spent on facili-

ties for the upkeep of modern locomotives and the saving in capital expenditure so realized is being felt as an increase in operating expenses.

#### NEW BOOKS

*Corrosion of Iron.*—By L. C. Wilson. Bound in cloth. 169 pages, 4¼ in. by 7¼ in. Published by The Engineering Magazine Company, 140 Nassau street, New York. Price \$2.

This book is a revision of a series of articles recently published in *The Engineering Magazine*. The author's purpose has been to assemble and condense the most interesting and important studies and facts connected with the corrosion of iron and its protection therefrom. Considerable practical information is included concerning materials available for the preservation of iron and steel.

*Scientific Management and Labor.* By Robert Franklin Hoxie, associate professor of political economy, University of Chicago. Bound in cloth. 302 pages, 5 in. by 7½ in. Published by D. Appleton & Co., New York. Price \$1.50.

Generally speaking, through improvements in industrial processes and elimination of wastes in the expenditure of labor scientific management is designed to serve the interest of employers and workmen alike, as well as society at large. That in many respects it has accomplished much toward this end cannot be denied. It has standardized facilities and processes, and has brought about co-ordination of effort where little better than confusion existed before. In its methods of dealing with labor, however, it has generally failed to win confidence, either because of the blind prejudice of organized labor or a lack of appreciation of the complexity of the labor problem. With the claims of the advocates of scientific management as to its relation to labor and those of the labor leaders, directly opposed to each other there has been practically no reliable information available from which an unprejudiced opinion on the merits of the controversy could be formed. Primarily to test the validity of these opposing claims as brought out at the hearings on scientific management held by the United States Commission on Industrial Relations in April, 1914, the author was commissioned to conduct a thorough investigation of the relations of labor to scientific management as they have developed in the operation of the three generally recognized systems.

The present volume contains the conclusions of the author based on the results of this investigation. The points at issue were carefully analyzed and a comprehensive study was made of scientific management as it was found in actual operation in 35 shops and other concerns. Care was taken throughout the investigation that it might be entirely impartial and to this end the author was assisted by a representative of employing management and a representative of labor, both of whom have fully approved the author's conclusions. In a number of appendices at the close of the volume are contained detailed statements of the labor claims of the three principal exponents of scientific management and the trade union objections to the system, together with a statement of the vital points at issue. The volume closes with the text of an elaborate questionnaire by the use of which most of the facts were obtained.

This volume is a valuable addition to the literature on scientific management and cannot fail to prove of great interest to all who are in any way concerned in the administration of the system, as well as to shop managers generally. The extravagance of the labor claims which have been made for scientific management is clearly indicated, some of them being inherently opposed to the system employed. It is also evident that there has been a disregard for the human element in all its complexity, throughout the system. Notwithstanding the numerous defects, however, "it is to date the latest word in the sheer mechanics of production and inherently in line with the march of events."

## COMMUNICATIONS

### A WORD FOR THE EFFICIENCY ENGINEER

TO THE EDITOR:

I have been greatly interested in reading the article in the December issue of the *Railway Age Gazette, Mechanical Edition*, entitled "How the Old Man Beat Him to It."

It would appear that Mr. Wolcomb has invaded the realms of fiction in his endeavor to parade "Old Dan" Keefe as a hero in the modern novel of "How the Old Man Beat Him to It"; he has relegated the efficiency engineer to the role of a dire villain, whose main object appears to be to get "Old Dan."

The primary theme, however, is predicated upon a fallacy, as the aim of an efficiency engineer, shop betterment specialist, or what not, is not the supplanting of present organization unless unresponsive, but rather the discovery of points for betterment, directing attention to them and aiding in their improvement. Efficiency is not magic, but is simply another term for common sense applied to the attainment of economy in the operation of shops and in the use of materials. Efficiency is the best attainable and can only be secured through comparative analysis.

The successful efficiency engineer is he who, not as Mr. Wolcomb leads us to believe, looks for opportunities to make radical alterations in equipment and facilities at a large expense, but rather for the best use of the facilities available and the improvement of these facilities at a slight cost. The efficiency engineer who did not have the power of analysis to recognize the reasons, which "Old Dan" was keen enough to perceive, as to why the patternshop should not be located immediately adjacent to the foundry, would be very weak. The economy of installing an electric crane in an old shop is questionable; those familiar with shop operation know that the time required to wheel or unwheel an engine with a long drop table or an electric crane is about the same. This by no means depreciates the value of a traveling crane, as it would be considered the height of folly to omit such equipment in a new building. Its use, however, may be questioned where old buildings must be adapted to receive a crane.

The same reasoning holds with motor drive for machine tool equipment. While highly desirable, no justification can be found for a wholesale installation of individual motor drive. Yet examples might be found where certain large machines and ones frequently called upon for overtime service could economically be so equipped, while in the main, if found desirable and economical to use electrical equipment, restricted group drive would be far more advantageous.

Again, does it seem conceivable that an efficiency engineer who really could claim such standing would be so inappreciative of fire hazards as to wander through a pattern shop smoking? Would he also be so lacking in tact and the appreciation of his co-operative function as to first look over a prospective field without making his presence known, explaining his mission and endeavoring to pursue his calling in harmony with the local organization?

Would he overlook the most important of all, the distribution and handling of material? It is the customary function of a shop betterment engineer to give this his first and careful attention, as without betterment in this respect no permanent improvement may be expected in the material costs.

Concerning the construction of machines instead of purchasing, an extremely questionable field of economy is entered. Shop kinks and jigs are of inestimable value, as is attested by the efforts directed by an efficiency engineer to their design and use, with substantial encouragements offered in efficiently operated plants for suggestions made by workmen. When, however, the field of the machine tool builder and designer is trespassed upon, it is severely to be criticised. There is hardly a railroad shop in the country, perhaps, but

could furnish one or two examples of misdirected efforts in this respect. Frequently, if all the misapplied costs entering into its construction could be ascertained, it is probable that its expensiveness would be self-evident, not to consider the greater cost of production.

And in conclusion, it is self-evident why "Old Dan" beat him to it, as Mr. Wolcomb's efficiency engineer has only the name to justify his profession, lacking a very essential qualification required to fit him for such an occupation: *i.e.*, an appreciation of the necessity for a systematic and co-operative co-ordination of purpose toward the attainment of improved and economical shop operation. MECHANICAL ENGINEER.

### THE MECHANICAL DEPARTMENT CLERK

WINNIPEG, Man.

To the Editor:

Referring to the communication in your April issue by A. C. Clark on The Mechanical Department Clerk. It would appear that the mechanical department clerk was giving something for nothing, whereas in reality, although he may be underpaid on a general average for what he does, he usually is getting a training that fits him for some other position. My experience may not be long enough perhaps to be representative, but I have been in a good many mechanical department offices and my observation is that, outside of the chief clerk, the rank and file of the office is composed entirely of young men who are drawing more money than they would had they been learning a trade. It is true also that these young men, as soon as they realize that they cannot pass a certain limit, take the first opportunity to better themselves elsewhere, and, judging from the appearance of our offices generally, it does not appear that to do so is very difficult.

Is not every job a "blind alley" job, unless we make it otherwise? It is said of the man who is left behind, that his responsibilities have raced ahead of his salary with his increasing years. This may be quite true, but in most cases the reason if traced will be found in the individual rather than in the job. A job may be practically the same for twenty years, and the same man may be at it, unless he makes the move or unless the company moves him. Competent men get advanced to other positions or else they advance themselves elsewhere. Some competent men lack the necessary spirit to make the break with a company which at least gives them the security of a steady, if small, income for fear that the new job with the smaller concern may not be suitable to them. It is this class, I take it, that our friend refers to as the "competents in a blind alley," and there is no doubt that there should be some better system of recognizing such faithful service as these men give on every railroad.

Various schemes are being used by different companies to help this situation and with varying success according to the application. The practice of having the department chiefs send in periodic staff recommendation sheets for the purpose of advancing deserving men to positions in other departments, appeals as being in the right direction. Other roads try to discover the unappreciated employee of merit by means of special service investigators, these latter being doubly useful in also finding ineffectual service.

While each of these systems has its merit, it cannot be overlooked that there is always the human element factor behind it all. There is always someone overlooked and always someone jumped ahead unfairly, at least so it appears. In the case of the mechanical department clerk, his scope is as wide as any other employee's. Under a broad system of advancement such as above mentioned, he can take a position in other departments with increased salary accordingly as his capabilities are recognized.

A SHOP ENGINEER.



# LOCOMOTIVES OF THE SANTA FE TYPE

Two Recent Engines with 2-10-2 Wheel Arrangement and Lateral Motion Front Driving Boxes

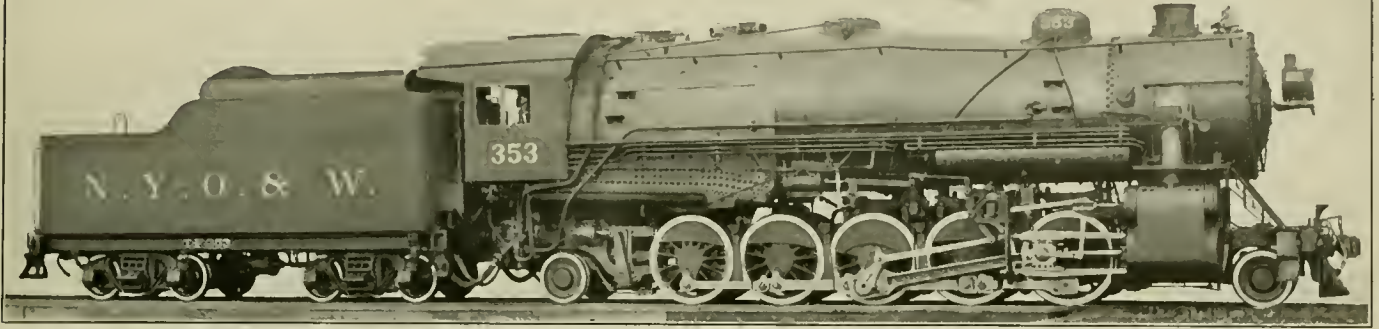

New York, Ontario & Western 2-10-2 Type Locomotive with Lateral Motion Driving Boxes

THE American Locomotive Company has recently delivered 12 locomotives of the 2-10-2 type to the New York, Ontario & Western and five to the Erie Railroad, the leading axles of which are fitted with patented lateral motion driving boxes. The 2-10-2 type has been handicapped by its long, rigid wheel base and the application of the lateral motion driving axles was made to keep the rigid wheel base within limits commonly met with on smaller types, at the same time securing the advantages of the increased capacity which may be attained with the ten-coupled wheel arrangement.

The lengths of rigid wheel base shown in the table are well within the figures used on a very large number of Mikado and Consolidation type locomotives in service throughout the country.

	Driving wheelbase	Rigid wheelbase
N. Y. O. & W. ....	20 ft. 0 in.	15 ft. 0 in.
Erie .....	22 ft. 6 in.	16 ft. 6 in.

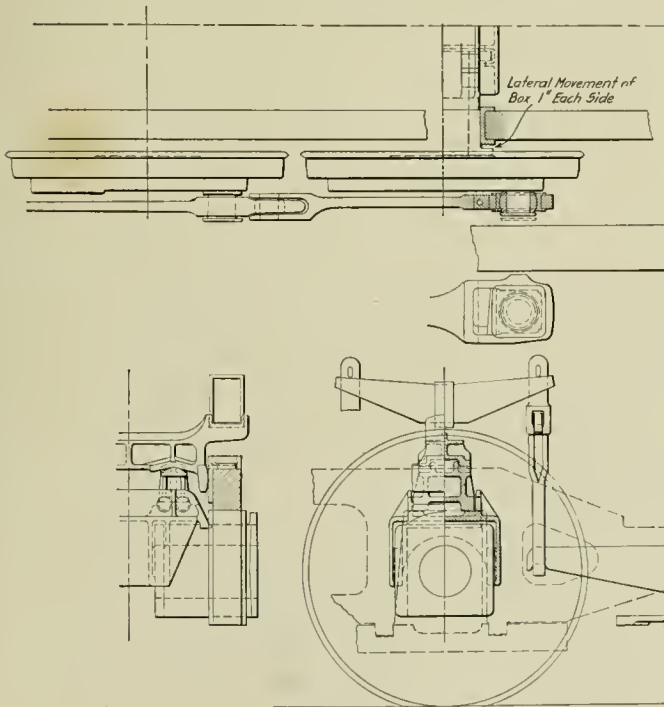

or spacing member which engages the inner flanges of the boxes. The weight, which is transmitted through this bridge member, is applied to the boxes on their transverse centers. The lugs which engage the inner flanges of the boxes are for the sole purpose of maintaining the proper spacing of the boxes and do not transfer any vertical load. The driving springs are in about the normal position and are carried on a cross member which has a vertical movement only between the engine frames, a wearing shoe being placed upon the inner side of the main frames to prevent side motion. Between this cross member and the bridge are interposed two inverted rockers designed so that a lateral force equal to 20 per cent of the weight transmitted is required to deflect them from their normal position. When the boxes are deflected from their normal central position by a side movement of the first pair of driving wheels, the boxes and the bridge casting are moved laterally relative to the member carrying the springs. This movement deflects the inverted rockers which offer a definite resistance against the motion. The spring and equalizer work is not shifted from its normal position by this movement.

It will be seen from the photograph and drawings that one side of the bridge member is carried below the driving axle with a bolting flange. This is provided for the attachment of a finger to guide the brake beam and insure that the brake heads register properly with the tires on the leading drivers.

The rod connections between the first and second drivers are arranged with ball knuckle joints ahead of the pins on the second drivers, which allow for the necessary deflection of the side rods. The construction of the crank pin and rod bearing at the first driver is clearly shown on the drawing. It consists of an ordinary design of cylindrical crank pin, on which is placed a hard bronze bushing, the outside of

6 1/2" Swing Each Side of Center

Arrangement of the Lateral Motion Journal Boxes and Flexible Side Rod Connections

The lateral box arrangement consists of two independent driving boxes, whose lateral centers are about on a line with the inside of the main engine frames. These two driving boxes are held in a fixed relation to each other by a bridge

which is turned to a spherical surface. Encasing this bushing are two pieces of hard steel which are held in place in the rod end with a wedge in the same manner as two ordinary brasses. The bushing can revolve either on the crank pin



or within the two steel pieces. When the rod is deflected from the normal position, the spherical bushing allows the parts to rotate sidewise around the center of the front crank pin; at the same time the bushing can revolve on the cylindrical portion of the pin. Several oil holes are provided through the bronze bushing to insure lubrication of both the spherical and cylindrical surfaces.

The operation of the lateral motion axle should be considered in connection with the engine truck. The driving

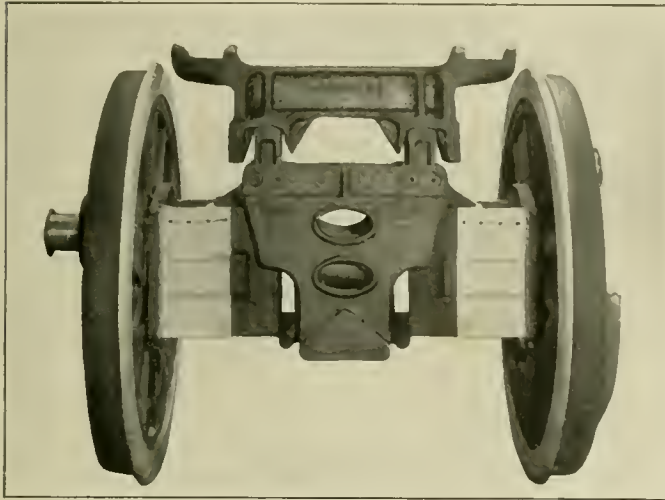

Lateral Motion Device Assembled on the Axle

springs of the first and second axles are equalized in the usual manner with the engine truck; therefore, the weight on the engine truck center pin and the lateral motion boxes on the first axle is divided in proportion to the arms of the front equalizer. The engine truck is of the inverted rocker type, having a resistance of 50 per cent against the initial movement, and, as previously stated, the resistance of the lateral device at the first driver is 20 per cent. These re-

lateral resistance is applied in the plane of each wheel instead of being applied midway between the wheels and divided between them as in the case of a four-wheel truck. As far as guiding the engine is concerned, therefore, the arrangement is very similar to a four-wheel application with the rear wheel of the truck acting as a driving wheel.

The resistance of the lateral motion box is proportioned with the idea of providing enough initial resistance so that for any ordinary road service on tangent track or curves the first driver will remain in normal position, and will deflect only when passing through turnouts and yard curves. The operation of the device in service has clearly demonstrated the correctness of the design in this particular. A close inspection of the engines in operation discloses the fact that the lateral motion driver very rarely deflects when the engine is running on the road. When the locomotive passes through sharp turnouts or is operating in yards, the lateral motion driver will deflect, thus preventing the cramping of the driving wheel base in the curve and limiting the pressure upon the driving wheel flanges.

It should be noted that the action of the rockers provides a limit to the lateral pressure which can be placed upon the first driving wheel flange. When this lateral resistance exceeds 20 per cent of the weight carried upon the lateral motion rockers the boxes will deflect, the excess lateral pressure being then transferred to the second driver, thus dividing the work of guiding the engine through curves between the truck and the first and second drivers instead of the truck and the first driver only, as in the ordinary ten-coupled arrangement.

The lateral motion driving boxes can also be applied to engines having four-wheel trucks.

In the ordinary design of 2-10-2 type locomotive, about 80 per cent of the total weight of the engine is on the drivers. It is therefore interesting to note the increase which has been obtained on these new engines, as shown in the table:

	Total Weight	Weight on Drivers	Percentage
N. Y. O. & W.	325,500	293,000	83.2
Erie	401,000	335,500	83.7

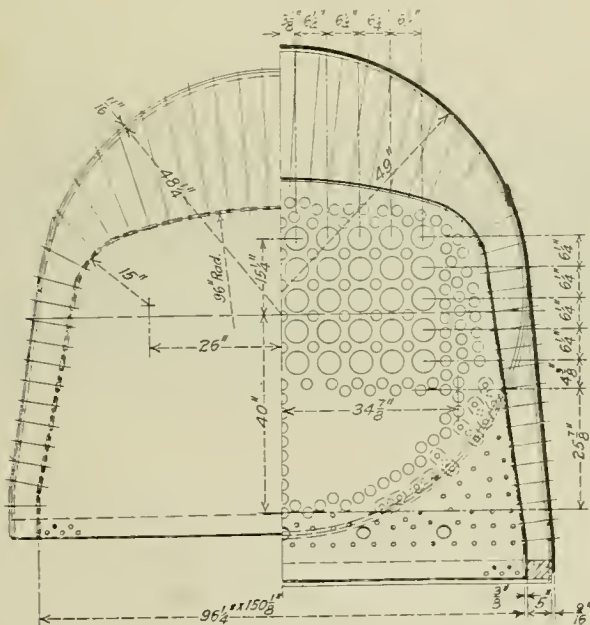

Cross Sections of the Boiler

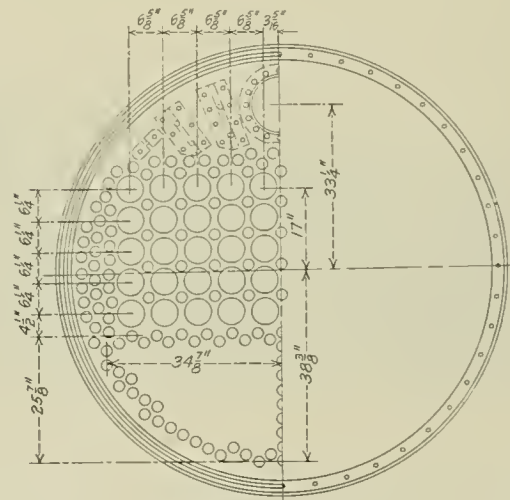

337, 2" Tubes 50, 5 3/8" Flues.

sistances are so chosen in relation to the weight coming upon each centering device that the lateral resultants at the engine truck and first driver are about the same in amount. It will thus be seen that in effect the engine truck and the first driver act in practically the same way as a four-wheel engine truck in guiding the front of the locomotive, except that the

Careful attention was given to the boiler design, and the boilers of both engines have the advantage of short tube length and large diameter. A short tube length not only gives greater evaporative value per square foot of heating surface, but also reduces back pressure and consequently increases the power of the engine. Large boiler diameter

combined with short tube length gives a large volume of water where the evaporative value is the highest.

The distance is short from the rear wheel to the draw bar in both engines. This not only makes the engine ride easier on curves, but it reduces the friction between the flange of the wheel and the rail.

The engines are equipped with superheaters, a combination Gains and Security arch, Street stokers, Baker valve gear, Ragonnet air reverse gear, Chambers throttle valve,

		Valves	
Kind .....		Piston	Piston
Diameter .....		16 in.	14 in.
Greatest travel .....		6½ in.	6¾ in.
Outside lap .....		1 in.	1 1/16 in.
Inside clearance .....		1/16 in.	
Lead in full gear .....		3/16 in.	¼ in.
		Wheels	
Driving, diameter over tires .....		63 in.	57 in.
Driving, thickness of tires .....		7 in.	7 in.
Driving journals, main, diameter and length .....		13 in. by 22 in.	12 in. by 22 in.
Driving journals, front, diameter and length .....		11 in. by 19 in.	10 in. by 13 in.

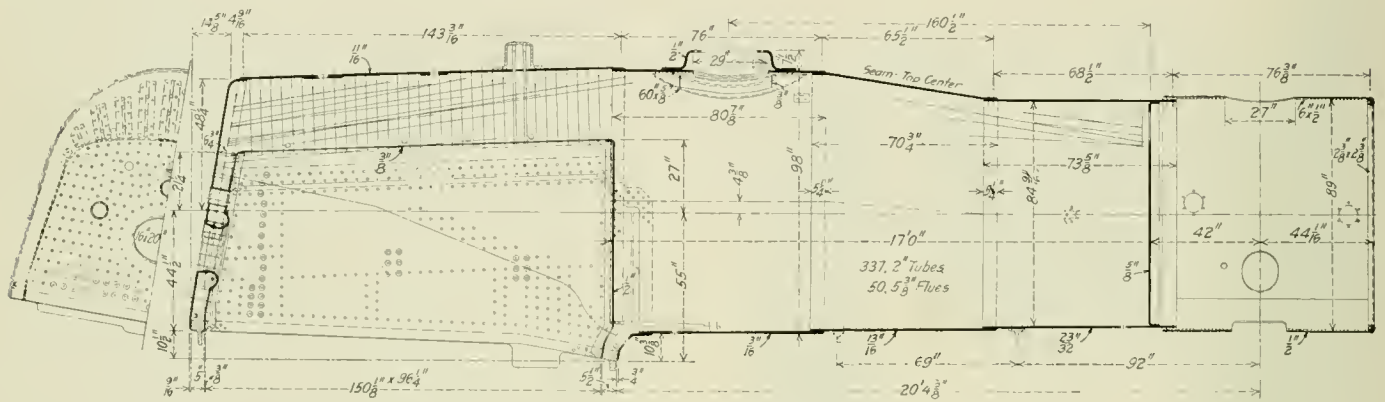

Boiler of the New York, Ontario & Western Locomotive

Economy front and rear trucks, and vanadium cast steel frames.

The following table gives the principal dimensions and data for both engines:

Driving journals, others, diameter and length .....	11 in. by 13 in.	10 in. by 13 in.
Engine truck wheels, diameter .....	33 in.	33 in.
Engine truck, journals .....	6½ in. by 14 in.	6½ in. by 12 in.
Trailing truck wheels, diameter .....	33 in.	33 in.
Trailing truck, journals .....	6½ in. by 14 in.	6½ in. by 12 in.

General Data

	Erie, 2-10-2	New York, Ontario & Western, 2-10-2
Gage .....	4 ft. 8½ in.	4 ft. 8½ in.
Service .....	Freight	Freight
Fuel .....	Bit. coal	Bit. coal
Tractive effort .....	83,000 lb.	71,200 lb.
Weight in working order .....	401,000 lb.	352,500 lb.
Weight on drivers .....	335,500 lb.	298,500 lb.
Weight on leading truck .....	34,000 lb.	30,000 lb.
Weight on trailing truck .....	31,500 lb.	24,000 lb.
Weight of engine and tender in working order .....	585,000 lb.	521,200 lb.
Wheel base, driving .....	22 ft. 6 in.	20 ft.
Wheel base, total .....	40 ft. 3 in.	36 ft. 9 in.
Wheel base, engine and tender .....	71 ft. 9½ in.	66 ft. 10 in.

Boiler

	E. W. T.	E. W. T.
Style .....	E. W. T.	E. W. T.
Working pressure .....	200 lb. per sq. in.	190 lb. per sq. in.
Outside diameter of first ring .....	92 3/8 in.	86 in.
Firebox, length and width .....	160 in. by 108 1/4 in.	150 3/8 in. by 96 1/4 in.
Firebox plates, thickness .....	{ Crown, sides, back, 3/8 in.; tube, 5/8 in. }	{ Crown, sides and back, 3/8 in.; tube, 1/2 in. }
Firebox, water space .....	6 in.	{ Front, 5 1/2 in.; sides and back, 5 in. }
Tubes, number and outside diameter .....	317—2 1/2 in.	337—2 in.
Flues, number and outside diameter .....	60—5 1/2 in.	50—5 3/8 in.
Tubes and flues, length .....	17 ft.	17 ft.
Heating surface, tubes and flues .....	4,617.5 sq. ft.	4,173 sq. ft.

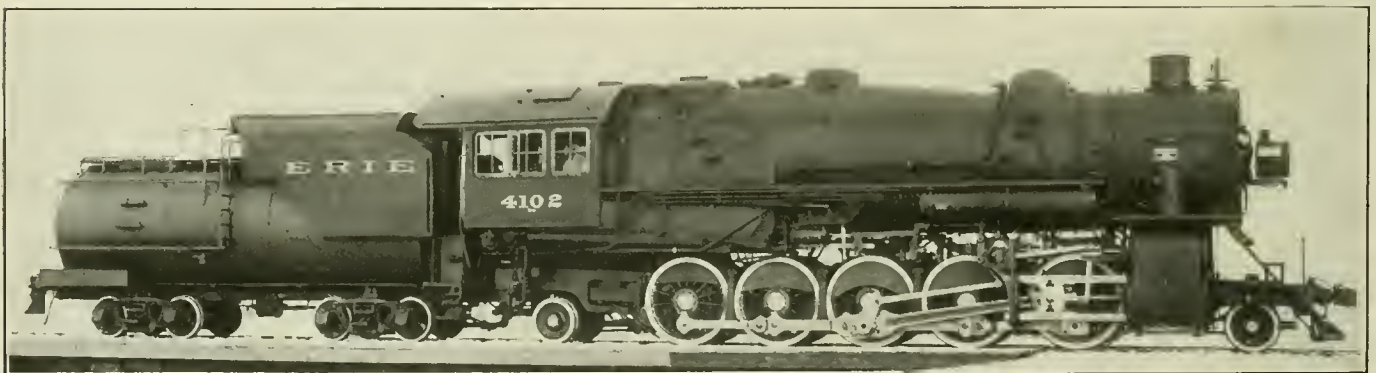

The Erie 2-10-2 Type Locomotive

Ratios			
Weight on drivers ÷ tractive effort .....	4.05	4.21	
Total weight ÷ tractive effort .....	4.83	4.95	
Tractive effort × diam. drivers ÷ equivalent heating surface* .....	760	677	
Equivalent heating surface* ÷ grate area .....	72.4	75	
Firebox heating surface ÷ equivalent heating surface*, per cent .....	4.97	5.42	
Weight on drivers ÷ equivalent heating surface* .....	48.8	49.7	
Total weight ÷ equivalent heating surface* .....	58.4	54.2	
Volume both cylinders .....	27.9 cu. ft.	22.7 cu. ft.	
Equivalent heating surface* ÷ vol. cylinders .....	246	264	
Grate area ÷ vol. cylinders .....	3.4	3.5	
Cylinders			
Kind .....	Simple	Simple	
Diameter and stroke .....	31 in. by 32 in.	28 in. by 32 in.	
Heating surface, firebox .....	† 341.6 sq. ft.	† 325 sq. ft.	
Heating surface, total .....	4,959.1 sq. ft.	4,498 sq. ft.	
Superheater heating surface .....	1,274.2 sq. ft.	1,007 sq. ft.	
Equivalent heating surface* .....	6,870 sq. ft.	6,008.5 sq. ft.	
Grate area .....	94.8 sq. ft.	80.2 sq. ft.	
Smokestack, diameter .....	23 in.	21 in.	
Smokestack, height above rail .....	16 ft. 3 7/16 in.	15 ft. 0 1/2 in.	
Tender			
Tank .....	Vanderbilt	Water bottom	
Weight .....	184,000 lb.	168,700 lb.	
Wheels, diameter .....	33 in.	33 in.	
Journals, diameter and length .....	6 in. by 11 in.	6 in. by 11 in.	
Water capacity .....	10,000 gal.	9,000 gal.	
Coal capacity .....	19 tons	15 tons	

\*Equivalent heating surface = total evaporative heating surface + 1.5 times the superheating surface.  
 †Includes arch tube heating surface.

## PREVENTION OF CORROSION IN PIPE\*

BY F. N. SPELLER, PITTSBURGH, PA.

Casual observation will show very marked differences in the degree of corrosion of pipe in service. For instance, hot water heating systems and sprinkler systems show practically no deterioration in service after 25 years, while low pressure steam returns sometimes give trouble after 15 years' service or less. Galvanized pipe in hot water supply systems where the water is heated under pressure, lasts from about five years upwards, depending on the temperature and quality of the water and volume of flow. The last named condition is so severe on iron and steel pipe that many are compelled to use brass pipe, at a cost approximately ten times that of galvanized pipe. These few instances are the extremes, but are surely suggestive when we consider that in pipe carrying ordinary water under some conditions there is no apparent deterioration in a generation; whereas in other cases, the same grade of pipe is seriously damaged in a very few years.

Some years ago, when steel pipe was comparatively unknown and not fully developed, it was natural to question this material, but comparisons of the modern wrought iron and steel pipe in the same lines in service have shown beyond any question that where corrosion is found one material suffers on the average as much as the other.

It has been the custom of the writer to keep several service tests under way continuously for the past few years. One of the most recent to be completed may be described as an example of the method pursued in conducting such tests. Four standard grades of pipe of well-known manufacture were selected and four pieces of each taken at random and coupled together alternately so that the hot water passed through each sample at the same temperature.

### DETAILS OF TESTS

Date installed—October 27, 1913.  
 Date removed—November 20, 1915.  
 Location—Hot water return line, Pennsylvania Building, Philadelphia  
 Temperature of water—175 deg. Fahrenheit, average.  
 Amount of water—5,000 gal. per day for 600 days.  
 Method of installation—In form of box coil.

### CORROSION MEASUREMENTS

Lot	Material	Sample Number	Depth of Pitting in Inches Average of 10 deepest pits in each piece	Deepest Pit
A	Steel	1	.068	.094
A	Steel	2	.087	.124
A	Steel	3	.045	.050
A	Steel	4	.063	.074
B	Steel	5	.079	.104
B	Steel	6	.056	.094
B	Steel	7	.054	.065
B	Steel	8	.070	.081
C	Iron	9	.065	.073
C	Iron	10	.072	.097
C	Iron	11	.078	.105
C	Iron	12	.077	.080
D	Iron	13	.055	.075
D	Iron	14	.067	.112
D	Iron	15	.067	.078
D	Iron	16	.073	.090
A	Steel	General Average	.066	.085
B	Steel	General Average	.067	.086
C	Iron	General Average	.073	.089
D	Iron	General Average	.066	.088

Inasmuch as both materials have been found to fail in about the same time under the same conditions, and as both have shown practically no deterioration after many years under other conditions, it would seem that with a correct understanding of the fundamental causes of corrosion a practical solution of this problem should be possible. The author has devoted a considerable portion of his time for the past ten years to a study of the factors governing corrosion of pipe in service, and is writing this paper in order to open up a more general discussion of measures for its prevention.

The inside of pipe is subject to peculiar conditions not to

be compared with external corrosion, and the inside surface is particularly vulnerable in that protective coatings are difficult to apply, therefore more liable to be defective.

Consider for a moment the situation in a hot water heating system and a hot water supply system where the temperature of the water is about the same. It is evident that the water alone is not responsible for the results observed, but rather something brought in with the water. The hot water heating lines have started to rust and then the action has apparently stopped, while in hot water supply lines the action is continuous and rapid; so much so, that if the pipe does not fail by leaking it may be plugged up tight with the reddish hydroxide of iron. The only way to account for this accumulation of oxide of iron is through the oxygen in solution in the cold feed water, amounting to 6 to 10 cubic centimeters per liter according to the temperature and quality of the water. This very small percentage of oxygen is apparently the measure of the destructive power of the water and accounts for the fact that a limited volume of water has no serious action on iron, whereas when this water is renewed continually, especially when heated, the results are liable to be most disastrous. It will be useful to consider the mechanism of corrosion before discussing ways and means for preventing this action.

All water supplies carry more or less foreign matter in solution. What are usually considered the purest natural water supplies are generally saturated with oxygen and carbonic acid, which cause such waters to be very corrosive, particularly when heated. Iron in all its forms is soluble in water to the amount of a few parts per million, depending on its composition and that of the water. In this treatise, in referring to water in connection with corrosion, it will be understood to include domestic supplies of the usual degree of purity. Chemically pure water does not occur in nature, and therefore may be omitted from consideration.

The phenomenon of solution is now generally explained as an electrochemical reaction. When pieces of zinc and copper are connected and suspended in water, a current of electricity starts to flow through the water from the zinc to the copper. The zinc is termed the anode and the copper the cathode. While the current flows the zinc goes into solution, the amount dissolved being proportional to the current, according to Faraday's Law.

If we replace the zinc with a piece of iron, a current flows in the same direction and iron will be found in solution. Suppose we now replace the copper with another piece of iron. A small current of electricity will still flow, but not necessarily in the same direction, this depending upon the relative condition of the surfaces of the two pieces of iron.

It is this small current flowing between one piece of iron and another under water which causes iron to enter solution, and this is now recognized as the *initial reaction of corrosion*. Solution is hastened by carbonic acid and mineral salts in solution, as these make the water a better electrolyte. However, it has been proved that iron will dissolve to some extent in the purest water that has yet been made. If the iron is exposed to nothing but water this reaction will soon cease, due to the accumulation of hydrogen at the cathode causing polarization; and this is what actually happens in practice in hot water heating and other systems in which the water and consequently the supply of free oxygen is not renewed. On the other hand, when oxygen is present it combines with the hydrogen, depolarizing the surface of the iron and thus causing solution of the iron to continue. Oxygen enters further into the reaction by combining with the ferrous hydroxide to form insoluble ferric hydroxide, generally known as rust. With an unlimited supply of water and oxygen, corrosion will continue

\* From a paper read at the January, 1916 meeting of the American Society of Heating and Ventilating Engineers.

until the iron is all converted into the form of ferric hydroxide.

So far most of the authorities are agreed as to the cause of corrosion, although there has been considerable scientific argument as to whether a trace of carbonic acid ( $\text{CO}_2$ ) is necessary or not for the solution of iron. For all practical purposes we can let this question rest and combine the acid and electrolytic theories into one, as outlined above, which affords the best explanation of the observed facts available at this time.

Ever since the electrochemical theory of corrosion was proposed by Whitney in 1903 there has been a division of opinion as to the cause of the difference of potential observed between two pieces of iron. The majority at first assumed that this was due to variation in composition of the metal, and the manufacture of iron of a high degree of purity in the open hearth furnace was heralded with great expectations as to durability. So far, after several years of trial it has not been found that such iron is so well adapted for the manufacture of pipe as the grade of soft weldable steel now generally used for this purpose.

In the year 1904 the writer started a study of the potential differences as found on the surface of iron of various compositions, and has invariably found just as much difference in potential on the surface of very pure iron as on steel or wrought iron of ordinary commercial quality. Subsequent observations, covering several years of service with pure iron, open hearth and Bessemer steel and wrought iron of the quality required for the manufacture of wrought pipe, have confirmed the conclusion expressed by the writer after his earlier experiments, viz., that composition has very little to do with the rate of corrosion of these metals under water. It should be remembered, however, that conditions underground or inside pipe lines are not the same as when exposed to the atmosphere, so that these conclusions do not apply to materials subjected directly to atmospheric conditions, such as metal roofing, which is another problem.

The tests and experiments referred to indicate that differences in finish and density of the material, particularly the character of the mill scale and how firmly it is attached, usually determine where corrosion starts and how it proceeds. The difference of potential due to surface influences was found to be many times greater than that due to variations in composition in the ordinary run of steel, and predominated over all other influences in nearly every case. These conclusions were tested in the most critical manner and have since been borne out by service tests of several years' duration.

Among the surface influences which directed the course of corrosion it was found that rust, when once formed, was nearly as potent as mill scale in its effect on corrosion. Some recent work by Mr. James Aston, M. E. of the U. S. Bureau of Mines, confirms these conclusions, but goes further in showing that the influence of rust in some cases is to render the metal underneath the rust anodic. As the mill scale is always the cathode, there is every reason to believe that we may have in certain places on the surface nearly double the difference of potential which was expected and this without reference to the actual composition of the iron or variations thereof. Everything seems to point to this explanation of the cause of pitting as being the true one. Under some conditions of service in water lines or boilers it frequently happens that the tubes, which prove to be of a high standard of quality as regards chemical composition, structure and physical properties of the metal have rapidly pitted through in places. The difference of potential and the current which thereby flowed from the exposed places to the firmly attached mill scale, especially after the exposed metal becomes covered with rust, affords a satisfactory explanation of the rapid pitting observed in such cases.

The current flowing between two points on the surface of a piece of iron is very difficult to measure accurately, and it might seem at first that such currents are too small to cause serious damage. A rough calculation based on some experiments will indicate the ultimate result from such currents acting continuously with certain submerged areas of electrodes:

1 ampere acting for 6 months, will dissolve 10 lb. of iron, or a plate 12 in. by 12 in. by  $\frac{1}{4}$  in. thick.

1 milli-ampere acting for 6 months, will dissolve .144 sq. in. of this plate, making a hole about  $\frac{7}{16}$  in. in diameter by  $\frac{1}{4}$  in. deep.

0.1 milli-ampere acting for 60 months, will perforate this plate with a hole of the same size.

This rate of pitting is not so far different from that experienced under some conditions of service. The remedy seems to lie in the elimination of dissolved oxygen from water before use. This may be accomplished in practice in at least two ways:

1. By allowing the hot water to come to rest for a few minutes under greatly reduced pressure. As no reliable data could be found on the amount of oxygen retained in solution in water at various temperatures and pressures, a series of experiments were run to determine these constants. The results indicate that the pressure must be reduced below normal or the temperature raised nearly to the boiling point with the water at atmospheric pressure to get proper separation of oxygen and other gases.

2. An alternative method of reducing corrosion in water lines by "satisfying" or "fixing" the free oxygen was tried out by the writer several years ago, using clean iron turnings. It was found difficult to get the scrap free from oil, and after rusting had progressed for some time there was a tendency for the mass to cake together and so impede the flow. By using sheet iron, so formed as to provide a large number of channels with about  $\frac{1}{4}$ -in. clear passage through which the hot water slowly percolates, we expect that these difficulties will be overcome. The rate of rusting varies with the surface condition of the plates becoming more rapid as the surface is covered with a good coating of oxide. The speed of rusting is 50 per cent more rapid at 110 lb. per sq. in. pressure than at atmospheric pressure, and, of course, the time required to "fix" the free oxygen of the water varies with the amount of surface of metal exposed per cubic foot and other conditions which are liable to vary. For these reasons, the results obtained were only relatively correct.

On this principle, two small plants have been equipped to carry out this method of treatment in practice. These systems were installed at places where considerable trouble has already been developed through the clogging and corrosion of galvanized pipes. These plants, which have only been operating a short time, show a reduction of oxygen contents from 8 or 9 c.c. per liter to 0.1 to 1 c.c. per liter according to the rate of flow and temperature. At present it seems desirable to design the plant so that the oxygen contents will be less than 1 c.c. per liter at all times, at which point corrosion seems to be reduced to a negligible amount. Some more definite data on this point will be available after these plants have been in operation for several months. The indications are that the rate of rusting of the plates, and hence the efficiency of the apparatus, will increase with time. Water should be in contact with the plates for at least ten minutes.

Similarly, the corrosion of low pressure steam lines will be found to depend principally on the amount of oxygen which finds access to the system. The return lines naturally suffer the most and are usually the first to show failure. Condensed water when freed from oxygen in solution is harmless, and will not even tarnish bright iron after months of exposure; but this water, on account of its great purity, has greater capacity for solution of oxygen than the average natural water and is therefore apt to be very corrosive when aerated. This may be prevented in large measure by using

an open feed water heater and keeping the water over 185 deg. Fahrenheit.

In some cases the surface of the pipe may be protected with a film of oil deposited from the steam. The writer's attention was recently called to the satisfactory results obtained in some buildings using exhaust steam which on investigation was accounted for by the thin film of oil found on the inside of these pipes. This was such an interesting matter that we made some tests in the research laboratory on long lines of new pipe and found that mineral lubricating oil, when dropped into a pipe carrying steam under pressure at the rate of two drops per minute, was carried forward in a fine state of division and in a few minutes was found condensed in a uniform film in the pipe about 160 ft. from the lubricator. While this simple means of protection would perhaps be objectionable in some cases, there are many steam heating systems where the oil could do no harm and might result in considerably prolonging the life of the lines. Of course, nothing but a good grade of mineral lubricating oil should be used, and the supply should be regulated by a reliable sight feed lubricator.

Summarizing very approximately, the influence of various factors on corrosion, it appears from the experience we have at present that developments in the metallurgy and manufacture of steel pipe promise to add 50 or perhaps 100 per cent to the life of pipe compared with the service obtained under like conditions ten or twelve years ago. However, it appears well within the bounds of possibility to predict that de-aeration of the water, through the use of plants designed with this end in view, should at moderate expense increase the life of some piping systems four or five times.

### TEST OF THE YOUNG VALVE AND VALVE GEAR

Comparative tests made by the Grand Trunk on two Pacific type locomotives of the same class, one equipped with Young valves and valve gear and the other with ordinary piston valves and the Walschaert valve gear, show a creditable performance for the Young valves and valve gear. This gear, which was described in the *Daily Railway Age Gazette* of June 11, 1915, page 1284, was the first of this

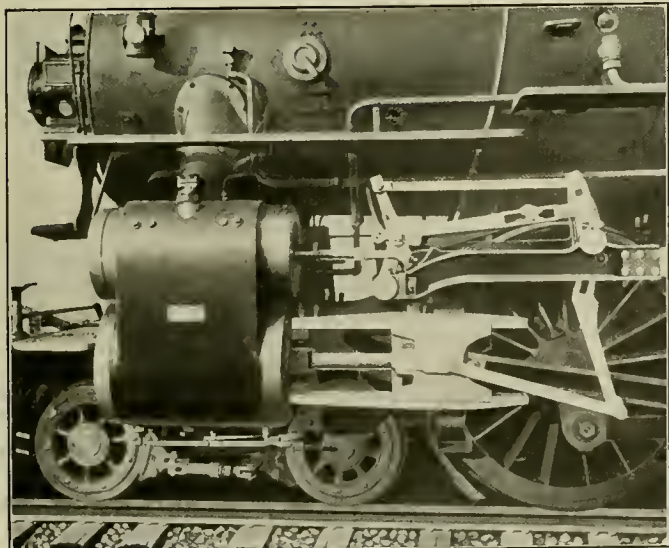

Young Valve Gear Applied to a Pacific Type Locomotive

type to be applied to a locomotive. It is the invention of O. W. Young who was for some years in charge of valve gear design for the American Locomotive Company, and it is controlled by the Pyle National Electric Headlight Company, Chicago.

The gear was designed primarily to give a better and more economical steam distribution. Of special interest is the performance of the engine at starting and at high speeds. A maximum cut-off of 88 per cent can be obtained with no detrimental effects to the other events of the stroke and it is possible to clear the cylinders of steam with practically no back pressure. This is shown by the indicator card, Fig. 1. This card was taken at starting, the speed being 5 m. p. h. The initial pressure is 184 lb. which is one pound less than the boiler pressure. The mean effective pressure is 173 lb., which gives an indicated tractive effort of 35,200 lb. This is 5,600 lb., or almost 19 per cent greater than the rated tractive effort of the engine. The back pressure lines of this card also show how easily the cylinder was cleared of the steam on the return stroke. This is the result of the extra long travel given the valve by the valve gear and the exceptionally open construction of the valve itself. A card taken at a speed of 40 m. p. h. with the Young gear is shown in Fig. 2, and Fig. 3 shows a card taken at the same speed with the Walschaert gear. The characteristics of these two cards are as follows:

	Fig. 2 Young	Fig. 3 Walschaert
Type of gear.....	Young	Walschaert
Speed .....	40 m.p.h.	40 m.p.h.
Boiler pressure .....	185 lb.	185 lb.
Initial pressure (cylinder).....	141 lb.	141 lb.
Mean effective pressure.....	76 lb.	45 lb.
Driving wheel diameter.....	72 in.	71 in.
Tractive power .....	15,440 lb.	9,270 lb.
Horsepower .....	1,645	988
Water per i. hp. hr.....	24.55 lb.	27.20 lb.

This comparison shows the advantage the Young gear has over the Walschaert gear, the conditions being the same in both cases. Still more interesting, however, is the performance of the Young valve and valve gear at high speeds.

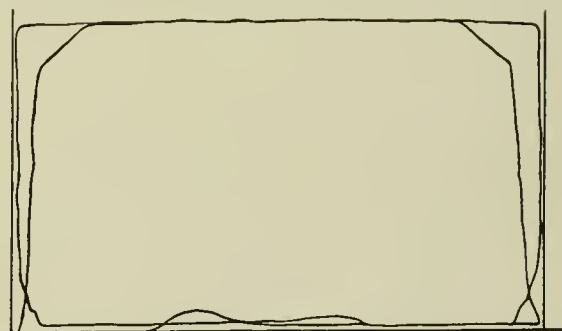

Fig. 1—Starting Indicator Card Taken with Young Valve Gear—Speed 5 Miles per Hour

An indicator card taken at a speed of 77 m. p. h. is shown in Fig. 4. The back pressure and compression lines are especially noteworthy. The back pressure is only 2.5 lb. and is remarkably constant throughout the return stroke when the speed at which the engine is running is considered. The compression curve shows that at even this high speed the cylinders are so well freed of steam that the compression could easily be begun at a point earlier in the stroke.

A study of these cards indicates that with this valve and gear a smarter engine is obtained at starting, more power is available and greater speeds are obtainable than with similar engines equipped with the Walschaert gear. In the report of the tests, shown below, it was stated that there scarcely seems to be any limit to the speed that this engine could make with the reverse lever in the twenty-first notch (almost at center) and the throttle only open a crack.

The tests were made on Pacific type locomotives of the same size and class, using superheated steam and having 23-in. by 28-in. cylinders with 185 lb. boiler pressure. Engine 293 was equipped with the Walschaert valve gear and engine 298 with the Young valves and valve gear. Both locomotives had made substantially the same mileage since

general shopping and were in practically the same condition. Engine 293 had drivers 71 in. in diameter, which gave it a rated tractive effort of 30,000 lb., while the drivers on engine 298 were 72 in. in diameter, giving it a rated tractive effort of 29,600 lb. One round trip was made with each engine in freight service and three in passenger service between Battle Creek, Mich., and Chicago. While the loco-

the handling of the engine during the tests it was found that the Young gear was operated with ease at high speeds and that there was no vibration in the valve stem at any time, indicating that the gear is under no severe strains. This was to be expected as the gear is some 1,100 lb. lighter than the Walschaert gear, and the Young valve is decidedly lighter than the valve ordinarily used. In this particular instance

AVERAGE TEST RESULTS PER SINGLE TRIP WITH YOUNG AND WALSCHAERT VALVE GEARS

Item.	Freight Service		Passenger Service		Engine 298 Compared with 293—Per cent	
	7 hr. 1 min. Young	7 hr. 38 min. Walschaert	4 hr. 27 min. Young	4 hr. 26 min. Walschaert	Freight Service	Passenger Service
Type of valve gear.....	298	293	298	293	.....	.....
Number of engine.....	1	1	3	3	.....	.....
Number of round trips.....	45	41	8.66	9	+ 9.8	- 3.7
Number of cars.....	1,612	1,485	.....	.....	+ 8.5	.....
Gross weight of train, tons.....	169	169	176	176	.....	.....
Train miles.....	7,605	6,844	1,526	1,584	+11.1	- 3.6
Car-miles.....	272,512	250,965	.....	.....	+ 8.5	.....
Ton-miles.....	11.92	13.31	8.82	10.40	-10.4	-15.2
Coal consumed, tons.....	3.20	3.9	11.58	13.35	-18.	-13.2
Coal per car-mile, lb.....	8.65	10.56	.....	.....	-18.1	.....
Coal per ton-mile, lb.....	173,044	187,250	107,602	118,860	- 7.5	- 9.4
Water evaporated, lb.....	7.25	7.08	6.13	5.73	+ 2.4	+ 6.9
Water evaporated per lb. of coal, lb.....	180	178	180	177	+ 1.1	+ 1.6
Boiler pressure, lb. per sq. in.....	24.14	22.33	39.71	39.65	+ 8.1	+ 0.15
Speed, m.p.h.....	7 hr. 1 min.	7 hr. 38 min.	4 hr. 27 min.	4 hr. 26 min.	- 8.	.....
Actual running time.....	1 hr. 36 min.	3 hr. 57 min.	23 min.	27 min.	-59.5	-16.6
Detentions.....	11	18	12	13	-38.9	- 7.6
Number of stops.....	40	17	41	26	.....	.....
Temperature, deg. F.....	.....	.....	.....	.....	.....	.....

motives are generally used in passenger service they were tested on freight runs for the purpose of seeing how the Young gear would perform in that service. The average results of the tests are shown in the table. These results show a slight increase in evaporation in favor of engine 298 indicating that it had slightly better steaming qualities but the percentage decrease in the coal consumed per car-mile

the reciprocating weight of the valve and gear has been reduced 40 per cent.

While this gear has not been in service long enough to determine its actual maintenance cost it is expected to prove more economical to maintain than the Walschaert gear and the ordinary piston valve. The Young valve is lighter due to the packings being carried in the valve bushing instead of the valve and this feature also permits the valve to be made much simpler in construction. The gear itself is also of simple construction. It derives its motion direct from the crosshead, there being no revolving parts. It is so designed that it can be made standard on a wide range of locomotives of various designs, and the valve can be used

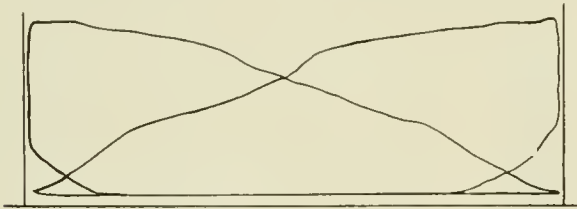

Fig. 2—Young Valve Gear Indicator Card at a Speed of 40 Miles per Hour

in passenger service and per ton-mile in freight service is far greater than that in the evaporation. In this connection it must be noted, however, that the tests are not strictly comparable because of the difference in temperature on the days the tests were made and also, in the case of the freight tests, because of the great difference in the time of detentions.

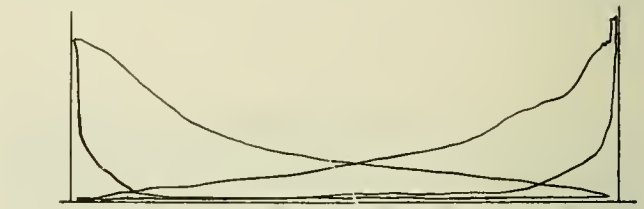

Fig. 4—Young Valve Gear Indicator Card at a Speed of 77 Miles per Hour

with any other type of valve gear. With the application of this valve and gear to locomotives it is possible to obtain the same results with a smaller diameter of valve than when the Walschaert gear is used because of the increased port openings made possible by the increase in the length of travel of the valve.

**BUCKLING OF FIRE TUBES.**—The buckling may result from relaxation of the stresses that are introduced by bending the tube to straighten it or for the purpose of getting it in the boiler, or may be due to one side of the tube becoming heated more than the other from carrying a low water level or from a deposit of scale on the tube.—*Power.*

**REDUCING BLOWDOWN OF SAFETY VALVES.**—Most pop safety valves are provided with an adjustable sleeve, or ring, that causes the escaping steam to react against the valve in such a manner as to assist the pressure of the boiler in holding the valve off its seat. By moving the ring farther away from the valve, there will be less reaction of the escaping steam and the amount of blowdown will be reduced.—*Power.*

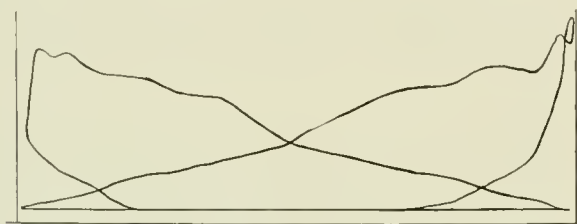

Fig. 3—Walschaert Valve Gear Indicator Card at a Speed of 40 Miles per Hour

that engine 298 had a marked advantage over engine 293 in starting trains and, as above noted, in making speed. Engine 293 was stalled on a grade about one mile west of Battle Creek with a train of 1,550 tons while engine 298 with poorer rail conditions made the same grade with practically the same tonnage at a speed of 13 to 15 m. p. h. In



# EXPRESS LOCOMOTIVES IN FRANCE

Six-Coupled Engines of the Four-Cylinder Compound Type Prevail; Schmidt Superheaters Used

BY EDOUARD SAUVAGE

With the exception of some locomotives of the Atlantic type, which are not likely to be reproduced, all the engines built in France for express passenger service since 1904 are six-coupled, either ten-wheelers (4-6-0) or Pacifics (4-6-2). Superheated steam is largely used, especially in the latest construction. With a few exceptions, the Schmidt standard superheater has been adopted.

Except on one road, all engines for express service have four cylinders, with a large proportion of compounds; in a few cases, single expansion, in four equal cylinders, is used, but the compound system appears altogether to be preferred. The one exception is the recent building, by the Midi Railway, of simple engines with only two cylinders, using superheated steam, for express service.

When the superheaters have been added to the four-cylinder compounds, the diameter of the high-pressure cylinders has been increased, the low-pressure cylinders being left unaltered. Piston valves are generally used on all cylinders, even on non-superheaters, but in a few cases, for instance, on Paris-Orléans engines, flat valves have been preserved on the low-pressure cylinders of superheater locomotives.

The usual practice is to have four separate valve motions, of the Walschaert type, for the different cylinders of the

box the collectors and ends of superheating pipes, have been taken off. No inconvenience seems to result from this suppression. Trouble would arise from a prolonged use of the blower, which may be avoided. If further experience proves that this mechanism can be dispensed with, including the steam cylinder for the automatic working of the damper, the saving in first cost and expenses for repairs will not be negligible, as well as the reduction in weight of about 660 lb.

The driver's station, that used to be on the right side of the engine, has been transferred to the left. Bogie wheels are, as a rule, braked.

Tables I and II give the leading dimensions of the latest 4-6-0 and 4-6-2 type locomotives for the different railway systems. Following are some details on the practice of each railway system:

TABLE I.

Principal Dimensions of Recent 4-6-0 Type Locomotives, with Superheaters

	East. 4-cyl. compounds	P. L. M. 4-cyl. compounds	State 4-cyl. simple	Nord, 4-cyl. compounds	Midi. 2-cyl. simple
Grate area, sq. ft....	34.02	32.07	29.92	29.71	29.92
†Heating surface sq. ft.	1,709.90	1,611.87	1,464.65	1,766.77	1,730.27
Superheat'g surf., sq. ft.	400.97	362.0	463.18	430.89	530.89
Tubes, number and	{ 21—5.23	{ 21—4.99	{ 22—5.23	{ 22—5.23	{ 24—5.23
outside dimen-	{ 28—1.93	{ 19—1.97	{ 139—1.97	{ 20—1.97	{ 143—1.97
sions, in.....	{ 75—2.76†	{ 64—2.76†	.....	{ 60—2.76†	.....

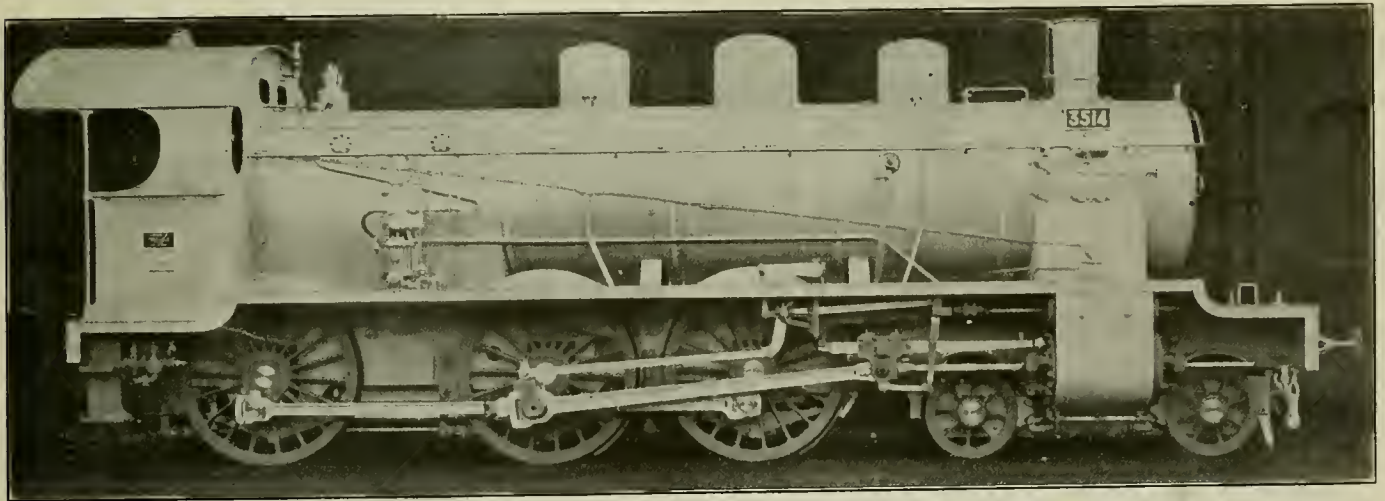

Midi Railway Two-Cylinder Simple Locomotive, Equipped with Superheater.

compounds; the reversing gear can operate at will the high-pressure and the low-pressure motions together, or only one of them. The starting device, when admitting steam directly to the low-pressure cylinders, opens a direct exhaust to the high-pressure. An exception is to be found on the Paris-Lyons-Méditerranéan engines: the low-pressure valve motion gives always the same admission backwards and forwards; it is operated by the same screw as the high-pressure motion, but is only transferred from one position to the other when reversing. The high-pressure valve motion being designed to give a very prolonged admission, the starting device comprises only a cock admitting live steam into the low-pressure cylinders, without special exhaust for the high-pressure.

As regards details it may be mentioned that, in some engines, the damper-box and doors, that enclose in the smoke-

Length between tube sheets, ft. in.....	14—5	13—1	14—1	14—1	.....
Mean diam. of barrel, ft. in.....	5—1	4—11	5—3	4—9	5—0
Height of center above rail, ft. in.....	8—10	8—6	9—2	8—7	.....
Working pressure, lb. per sq. in.....	227.6	227.6	170.7	227.6	170.7
Diameter of driving wheels, in.....	82	79	80	69	69
Diam. of cyls., in.....	{ 15.35	{ 14.57	{ 16.93	{ 14.96	{ 23.23
	{ and 23.93	{ and 21.27	.....	{ and 21.66	.....
Stroke of piston, in..	27	24	25	25	25
Weight in working order, long tons.....	76.9	72.0	70.4	68.6	75.1
Weight on drivers, long tons .....	52.3	50.2	48.1	49.0	53.1

\*488.4 sq. ft. with Mestre's superheater.

†Serve ribbed tubes.

‡In France the heating and superheating surfaces are generally computed on the fire side, including the whole surface of the ribs of serve tubes. An exception is made on the East Railway.

## EAST RAILWAY

Other systems of superheaters besides the Schmidt have been experimented upon. First, for fear of overheating the

\*From a paper presented before the Institution of Mechanical Engineers.

high-pressure cylinders, superheating in two stages was resorted to, high-pressure steam being moderately superheated, while receiver steam passed a second superheater. This plan has been abandoned. A helical superheater, on the principle

tance being reduced to 21.7 in. It has been found that these castings rapidly become covered with a slag deposit that protects them from a too intense heat.

With the exception of the points mentioned, the several

TABLE 11  
Principal Dimensions of Recent Pacific Type Locomotives

	P. L. M.		State 4-cyl. compounds	Nord. 4-cyl. compounds	Paris-Orleans		Midi	
	4-cyl. compounds	4-cyl. simple			4-cyl. com- pounds without superheater	4-cyl. com- pounds with superheater	4-cyl. compounds	2-cyl. simple
Grate area, sq. ft.....	45.75		45.96	34.67	45.96	43.27	43.06	
Heating surface, sq. ft.....	2,175.3	2,360.6	2,270.84	2,292.5	2,768.99	2,271.95	2,328.12	
Superheating surface, sq. ft.....	693.98	760.28	683.5	484.4	.....	673.9	655.3	
Tubes, number and outside diameter, in.....	28—5.23 143—2.17		24—5.23 151—2.17	24—5.23 90—2.76*	..... 257—2.17	24—5.23 151—2.17	24—5.23 145—2.24	
Length between tube sheets, ft. in.....	18—0.53	19—8	19—4.3	14—9	19—4.3	.....	.....	
Mean diameter of barrel, ft. in.....	5—5.39	5—6	5—6.13	5—4.61	5—6.13	5—6.13	5—6.13	
Height of center above rail, ft. in.....	9—9.7		9.42	9—3	9—4.2	.....	.....	
Working pressure, lb. per sq. in.....	227.57	199	227.57	227.57	227.57	227.57	227.57	
Diameter of driving wheels, in.....	79		76.4	80	76.4	76.4	76.4	
Diameter of cylinders, in.....	17.33 25.59	19	16.54 and 25.20	16.14 and 25.62	15.35 an 125.20	16.54 and 25.20	15.75 and 24.41	
Stroke of pistons, in.....	25.59	..	25.59	25.98	25.59	25.59	25.59	
Weight in working order, long tons.....	89.8	91.6	93.6	84.2	88.9	90.7	89.9	
Weight on drivers, long tons.....	54.9		53.1	48.4	51.7	52.1	53.1	

\*Serve tubes.

of the Field tube, with ribs, was fitted to some engines, and was abandoned, too, on account of its insufficient surface and of the difficulty of cleaning its outside ribs. Another system is the Mestre squirrel-cage superheater, which is

lots of these engines show but slight differences. The principal dimensions are given in Table I. The heating surface is computed on the side in contact with combustion gases; in the case of Serve tubes, it is reckoned as the mean between

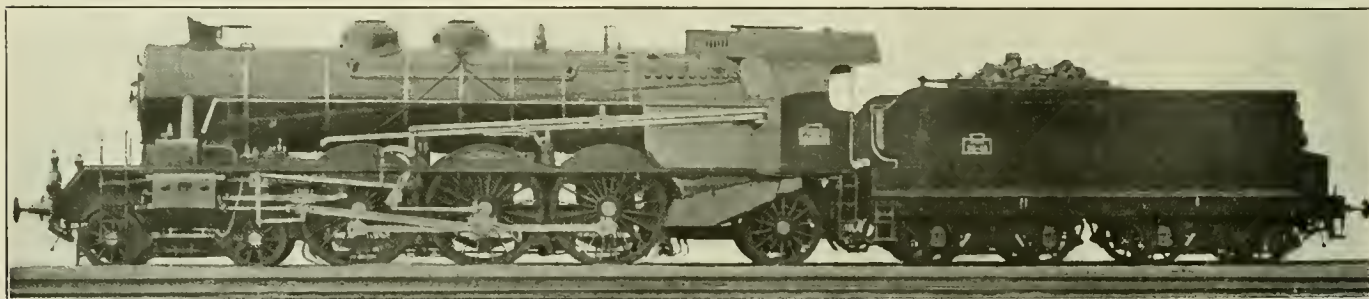

Paris-Lyons-Mediterranean Pacific Type Locomotive

working on some engines and gives ample surface. In some engines the receiver comprises a number of large pipes in the smoke-box with a heating surface of 83.3 sq. ft., the object being to dry or even to superheat the low-pressure steam.

the actual surface ribs included\* and the surface of a plain tube of the same inside diameter. The surface of the superheaters is the mean between their inside and outside surfaces.

These engines have six-wheeled tenders, holding 4,850

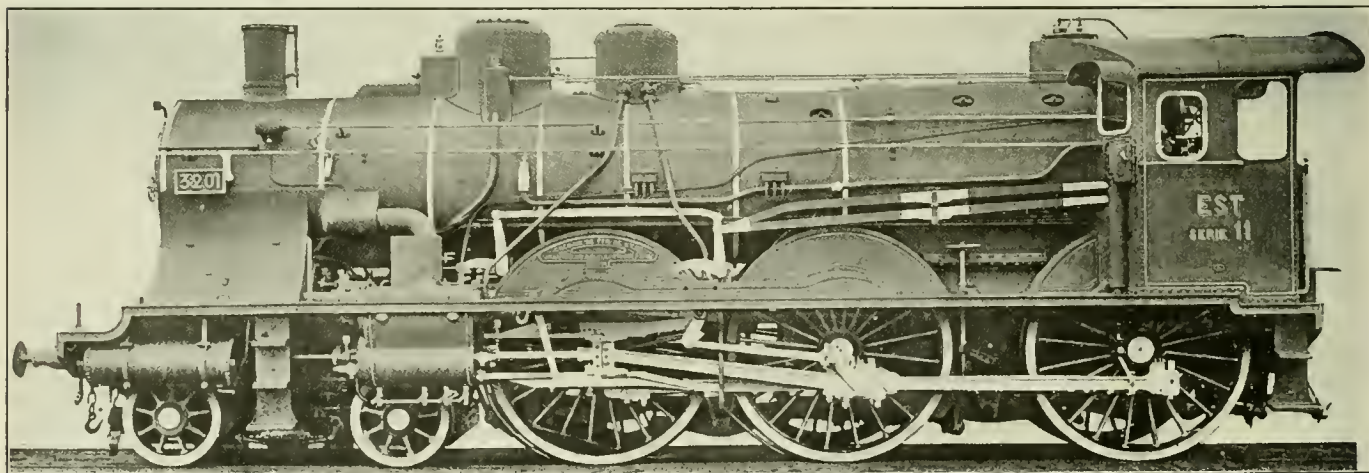

Ten-Wheel Locomotive Used on the Est Railway

This contrivance does not seem to have any well-marked effect.

The ends of the superheating tubes, which are steel castings in Schmidt's system, come close to the firebox, the dis-

Imperial gal. of water and 8 long tons of coal, weighing empty 20 long tons. Mr. Lancrenon, chief engineer of the East Railway, declares these six-coupled engines give entire satisfaction. Although utilized mainly for fast trains, they

can negotiate all passenger, and even occasionally heavy freight trains. They attain easily the limit speed of 74.6 miles an hour and run smoothly without injuring the track; the expenses for keeping up, as well as coal and water consumption, are moderate.

As regards boiler pressure, the practice of the East Railway is to reduce the maximum allowed by one unit, so as to be certain that this maximum is never exceeded. On boilers marked 227.6 lb. per sq. in. the safety valves blow off at 213.35 lb. per sq. in.

#### PARIS-LYONS-MEDITERRANEAN

Comparative trials of No. 6102 (simple, 4-6-2 type, superheater) and No. 6204 (compound, 4-6-2 type, super-

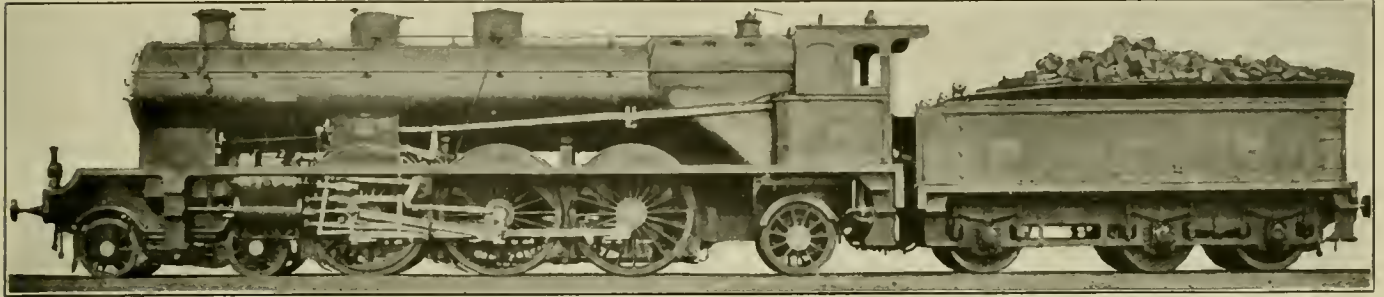

Paris-Orleans Pacific Type Locomotive

heater) were made on this road between Laroche and Dijon, the line rising from Laroche to Blaisy (82.0 miles) with long continuous grades of about 1 in 200.

With trains weighing as much as 487 tons, locomotive 6102 (simple) indicated 2,051 hp.,\* the utilized power on the draw bar being 1,364 hp. The water consumed per hour and per indicated horse power varied, in the different experiments, from 19.1 lb. to 21.5 lb., the gross coal consumption, including lighting up of fires, from 3.42 lb. to 40 lb., and the net coal consumption (deduction made for lighting up) from 2.98 lb. to 3.5 lb. In some cases as much as 1,543 lb. of coal were shovelled in per hour and for each 10.764 sq. ft. of grate.

Compound locomotive 6204 hauled trains of 646 tons at

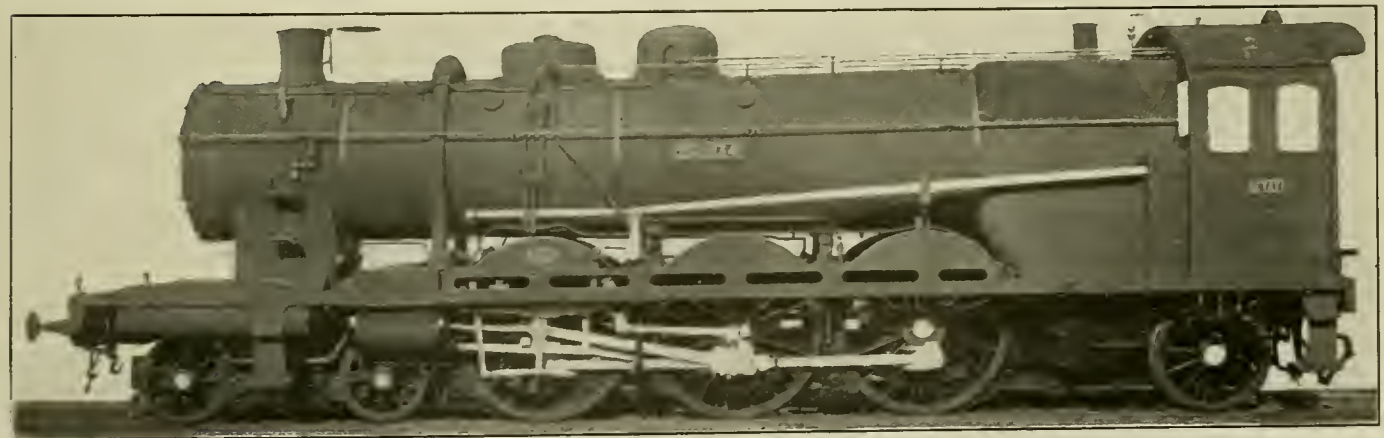

Pacific Type Locomotive Used on the French State Railways

an average speed of 49.7 miles to 55.9 miles an hour from Laroche to Blaisy; 2,425 hp. was indicated and 1,604 hp. registered by the dynamometer on the drawbar. The water consumed per hour and indicated horse power varied from 13.51 lb. to 15.03 lb., the gross coal consumption from 2.27 lb. to 2.69 lb. The rate of combustion never exceeded 1,183.9 lb. per hour and for each 10.764 sq. ft. of grate.

\*1 French hp. equals 542.5 ft. lb. per second.

#### STATE RAILWAYS

No precise experimental data, referring to the types of engines mentioned, are available. As regards the comparison of simple four-cylinder engines versus compounds, all with superheaters, the impression of some officials of the State railways seems to be in favor of the compound principle.

#### NORD

The locomotives used for fast trains on the Nord since 1904 are all four-cylinder compounds. They consist of 35 of the Atlantic type; 150 of the 4-6-0 type; 2 Baltic\* type engines (4-6-4), and 20 Pacific type.

The six-wheel tenders of some of these engines have been designed with a view of reducing, as far as possible, the fire-

man's work. The coal tank is entirely in front, with a bottom sloping at an angle of 45 deg. On both sides, auxiliary tanks are provided for briquettes, which are also close at hand.

Owing to the moderate diameter of their wheels, these engines may be used for every kind of service; they negotiate heavy freight as well as fast passenger trains. This has proved a great convenience on the Nord, where in the fall of the year the freight traffic is heavy, while in summer and on holidays a large number of supplementary expresses, all heavy, have to be run.

It was not thought advisable to build more locomotives of the Baltic type before a longer experience; for this reason 20 Pacific type engines were placed in service at the end of

1912 with the same diameter of wheels that the Atlantics had, but with a greater power and more adhesive weight. The principal dimensions of these Pacifics are given in Table II.

One peculiarity of these engines is the use of by-passes on their high pressure cylinders instead of air relief valves. After the results of experiments on the first of these engines,

\*For description see *American Engineer*, April, 1913, page 190.

the section of the steam pipes, the length of ports of the high pressure cylinders, and the travel of the valves was increased, with a notable gain of power. The indicated power in regular working attains 1,900 hp. to 2,000 hp.; 2,120 hp. was obtained on one occasion. With a train of 422 tons the speed has been increased from 21.7 to 57.2 miles an hour on the 1 in 200 grade from St. Denis to Goussainville. On the 1 in 125 grade from Marquise to Caffiers, 4.97 miles long, the speed fell from 64.6 miles to only 46.6 miles an hour, with the same train.

Superheating has been adopted for all recent Nord engines, and will be continued in future engines; with steam temperatures of 300 deg. to 340 deg. C., no undue expenses for repairs have been experienced. The Nord engineers are of opinion that superheating and compounding must be combined.

The two Baltic type engines are mere experiments. As regards power they are far in advance of the Pacifics, but far less economical.

#### PARIS-ORLEANS

The shape of the firebox of the Paris-Orleans Pacific type engine is peculiar; it extends over the back trailing wheels, but also extends between the last pair of drivers, the object being to avoid a shallow box. Reports of the working of this style of firebox are quite satisfactory. Owing to the great length of the tubes, 19 ft. 4 in. between tube sheets, plain ones without ribs have been adopted, with an outside diameter of 2.17 in. The necessity of increasing the diameter of very long tubes is obvious; but the reason why they are not of the Servé system is not evident. It may be that a sufficient heating surface being obtained with plain ones, it is better to avoid the increase in cost and weight of the ribbed tubes.

Indicator diagrams on the superheater engine made apparent a too high compression in the high pressure cylinders. The clearance being enlarged, a smoother running was obtained without any increase of steam consumption. Experiments with fast and heavy trains showed an indicated power up to 2,180 hp. and 1,266 hp. on the drawbar behind the tender.

An interesting comparison was made in actual running of twenty Pacifics without and of fifteen with superheaters, taking in turns the same trains. The mean coal consumption per 100 ton-kilometre was, in winter, including steam heating of the trains, 8.64 lb. for engines without superheaters, and 7.74 lb. for engines with superheaters. In summer the figures were, respectively, 7.78 lb. and 6.99 lb. These figures show an economy averaging 10 per cent in favor of the superheat.

#### MIDI

During the last decade the Midi Railway has added to its motive power a number of Atlantic ten-wheel and Pacific type locomotives. The leading dimensions of the latter types are given in the tables.

**ALL-STEEL TRAIN IN INDIA.**—The Great Indian Peninsular Railway has recently put in service the first complete all-steel train in India. The train was built in England, shipped to India in parts and put together in the shops at Bombay.

**PROPERTIES OF AUTOGENOUS WELDS.**—The strength of the joint produced by autogenous welding has been a fruitful source of discussion in the application of the process, and many contentions have been advanced as to the necessity of welds of highest tensile strength. It was early found that welds having a breaking strength equivalent to that of the metal itself could be produced, but the sacrifice of elongation and reduction of area materially lessened the apparent value of such welds.—*Valve World*.

## GREASE LUBRICATION OF LOCOMOTIVE DRIVING BOXES

BY GEORGE J. BURNS  
President, Burns System, Inc., Chicago

To the extent of the writer's observation there is but one railroad applying grease lubrication to its locomotive driving boxes in accordance with scientific principles, which are so simple, obvious and well recognized that, were they not disregarded, their mere enumerations would be inexcusably elementary.

Lubrication is the intervention between sliding surfaces of a substance the properties of which are such that: a film of it adheres to each surface; the molecules, beyond the adhering zone, roll over and slide upon each other with a minimum amount of frictional resistance. The principal rule of lubrication is to introduce the lubricant at the point of least resistance and to prevent its escape at the point of greatest pressure. A set of gages applied to the side of a driving box, the journal of which runs in a bath of oil, indicates that the pressure is zero at the point where the oil enters, and that it gradually increases up to a point just over the crown in the direction of the movement of the journal, from which point it rapidly falls off. It is to be observed, as confirming this, that a crown brass wears upward and slightly forward.

A properly designed driving box with a grease cellar is a most effective example of force lubrication. As the journal revolves, the molecules of the lubricant between it and the crown brass slide and roll over each other, each being pushed forward by the combined pressure of those behind it. The forward movement might be compared to that of anti-friction ball bearings. The efficiency of lubrication is dependent upon the maintenance and forward movement of an intervening film of the lubricant, the forward pressure depending upon the speed of the journal. The rate at which the forward movement of the lubricant takes place is dependent upon the pressure and the fluidity of the lubricant. As the lubricant not only reduces the coefficient of friction but absorbs and carries away heat and flushes the bearing, its forward movement through the bearing is essential.

When driving boxes were lubricated with oil, introduced through a hole at the top, the movement of the journal tended to keep the oil from the back quarter of the bearing. It was, therefore, necessary to cut radiating grooves in the face of the crown brass in order that the lubricant might flow by gravity to the portion of the journal that the oil could not otherwise reach. Lubrication by a grease cellar being the reverse of oil lubrication, grooves are not only unnecessary but are a positive obstruction to lubrication. They are not a factor in drawing in the lubricant and they provide a means for its escape at the point of greatest pressure where it is most needed. They reduce the bearing area of the crown brass and if left in the scale they tend to cut and roughen the journal.

Like many other railroad mechanics, the writer accepted the opinion of the manufacturer of the grease cellar until through constant observance he had come to accept grooves in a crown brass as an essential element of driving box design. He was, therefore, not a little surprised to note their omission on one road, and that their omission was attended by a decrease in the number of hot boxes. Appreciating that every result has a cause, his attention was directed to a study of the principles of lubrication.

The greatest handicap to increased efficiency in railway shops is an obsession resulting from a long observance of "usual" practices.

**DOUBLE-ECCENTRIC ENGINE.**—Engines known as double-eccentric engines are provided with one eccentric for operating the admission valves and another for operating the exhaust valves.—*Power*.



EXAMPLES OF RECENT LOCOMOTIVES OF THE MALLET AND MIKADO TYPES

ARRANGED IN ORDER OF TOTAL WEIGHT

Table with columns for Type, Name of road, Road number or class, Boiler, When built, Tractive effort, lb., Weight, total, lb., Weight on drivers, lb., Weight on leading truck, lb., Weight on trailing truck, lb., Weight of tender, loaded, lb., Wheel base, driving, ft. & in., Wheel base, total engine, ft. & in., Wheel base, engine and tender, ft. & in., Diameter of drivers, in., Cylinders, number, Cylinders, diameter, in., Cylinders, stroke, in., Valve gear, type, Steam pressure, lb., Boiler, type, Boiler, smallest outside diameter, in., Tubes, number and diameter in inches, Flues, number and diameter in inches, Length of tubes and flues, ft. & in., Heating surface, tubes and flues, sq. ft., Heating surface, (reboiler), sq. ft., Heating surface, total, sq. ft., Heating surface, (superheater), sq. ft., Heating surface, equivalent,\* sq. ft., Grate area, sq. ft., Firebox, length, in., Firebox, width, in., Kind of fuel, Tender, fuel capacity, tons or gallons, Tender, water capacity, gal., Weight on drivers ÷ tractive effort, Total weight ÷ tractive effort, Tractive effort X dia. drivers ÷ equivalent heating surface, Equivalent heating surface\* ÷ grate area, Firebox heating surface ÷ equivalent heating surface, per cent., Weight on drivers ÷ equiv. heat. surface, Total weight ÷ equiv. heating surface, Volume both cylinders, Equiv. heating surface\* ÷ vol. cylinders, Grate area ÷ vol. cylinders, Reference to photographs, drawings or description

\* Equivalent heating surface = total evaporative heating surface + 1.5 times the superheating surface. † Includes arch tube heating surface. ‡ Includes combustion chamber heating surface.

# CAR DEPARTMENT

## PORTABLE SCAFFOLD FOR CAR REPAIR TRACKS

BY E. W. HARTOUGH

General Foreman, Car Department, Missouri, Kansas & Texas, Denison, Tex.

The illustration shows a portable scaffold which has been adopted at this point for use on repair tracks where the means of building a permanent scaffold are not available. The scaffold board is 12 in. wide and 10 ft. long and it will be noticed that there is a pair of drop handles at each end for use in moving the scaffold about the yard. When not in use these handles drop down beside the end frame where they are out of the way and in no danger of being broken off. At one end the legs are fitted with small rollers which facilitate moving the scaffold about. These rollers make it possible for one man to handle the structure and also protects the legs from being broken by dragging it about in adjusting it to the work.

It will be noted that the horizontal braces near the bottom which connect the two end frames are sprung in at the

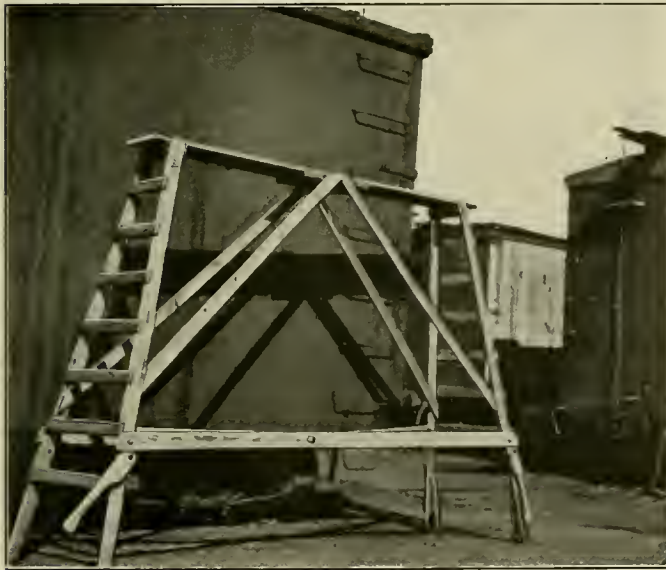

Portable Scaffold with Rollers and Drop Handles

center and bolted together. This makes a much stronger brace than would two straight pieces and also leaves room for a man standing on the ground to work between the brace and the side of the car. It is of advantage in placing the scaffold around the corner of a car or across the end, where the coupler would interfere with a straight brace and make it impossible to get close to the end of the car.

**SMOKE AS AN INDICATOR OF EFFICIENCY.**—In burning oil as fuel, dense smoke may indicate that a very considerable proportion of the fuel is going to waste from imperfect combustion; but in burning coal a smoky chimney does not necessarily indicate serious inefficiency of firing, as the losses due to visible smoke seldom exceed 2 per cent. Dense clouds of smoke may result from the operation of a furnace with minimum air supply and incomplete combustion that will give a higher evaporation per pound of fuel than where the furnace is made smokeless by a larger excess of air, causing much greater losses of heat in the chimney gases.—*Power.*

## NUMBERING REPAIR PARTS OF CARS

BY W. H. HAUSER

Mechanical Engineer, Chicago & Eastern Illinois

It has been standard practice for years for railroads to number all locomotive, car and miscellaneous castings with individual numbers and to issue a blue-printed or some

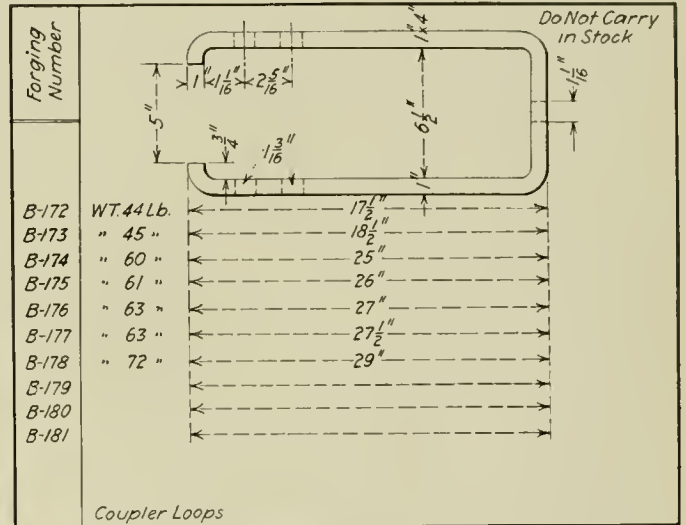

Fig. 1—Example of Classifying Detail Repair Parts

other type of pattern record to all storekeepers and foremen interested in the use of such a record. Some roads, on account of their size and the diversity of classes of power, have been forced to adopt quite complicated pattern num-

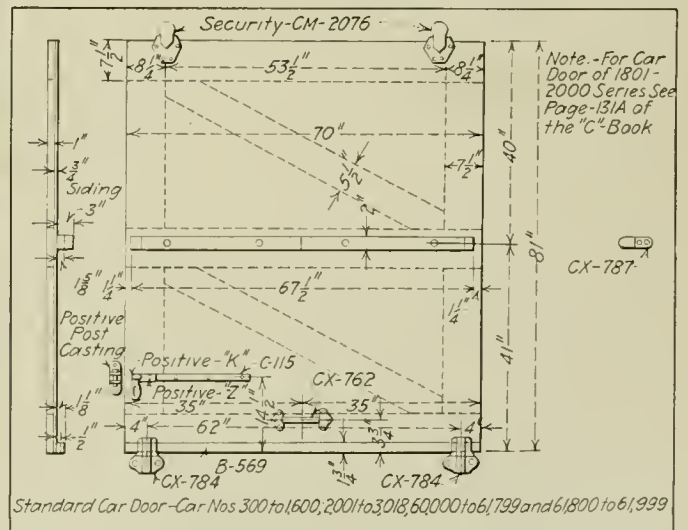

Fig. 2—Identification Drawing for Box Car Doors

bering systems. Other roads have found the simple numbers, with the prefixes as shown below, the most satisfactory:

L B 1000 meaning, a locomotive (L), brass (B), casting number 1000  
 L S 1000 meaning, a locomotive (L), steel (S), casting number 1000  
 L C 1000 meaning, a locomotive (L), cast iron (C), casting number 1000  
 L M 1000 meaning, a locomotive (L), malleable iron (M), casting number 1000  
 and so on.

We have extended this system of record and numbers to

forgings, standard practices, steel work details and safety appliances of all kinds on freight and passenger cars. We have made up and issued to all storekeepers and freight car foremen a book named "Freight Car Forgings and Standard Practices." This book, in a convenient size of 10 in. by 14½ in., shows at least two forgings on each page. It is known to all men using it as the "B" book, since we use the prefix "B" in numbering freight car forgings. In the book are shown arch bars, brake levers, all kinds of brackets, hangers, loops, pins, rods, carriers, special bolts, etc. These are all shown in detail so that forgings can be made from the drawings. The size of material used and the weight per piece is also noted.

Fig. 1 illustrates the plan. B 172 to B 178 are miscellaneous 6½ in. coupler loops. They are not our standard, but cover sizes that are occasionally used. They are not carried in stock, and are to be made as needed. In case a car foreman orders a 6½ in. loop not shown on this sheet his storekeeper can immediately call his attention to the fact

show the "C" book details. These drawings are given numbers in addition to the "C" book numbers to facilitate ordering from manufacturing concerns. This book also permits of the store department painting these numbers on the pieces as they are received and checked and also to sort and file them for easy identification. The idea of steel details having "C" numbers and forgings "B" numbers greatly aids all concerned in efficient handling.

In addition to the above there are all the safety appliances forgings. These we give an "SB" number showing that they are safety (S) forgings (B). An assembly drawing shows all the various forgings and the application necessary to bring one of these cars up to U. S. Safety Appliance Standard requirements. Smaller sheets show the exact details of these forgings. They are made into a book 7¼ in. by 10 in. over all, including a binding edge.

Car men and storekeepers will appreciate how much such a simplified record means. There is no more ordering by name with each man using a different name. No ordering

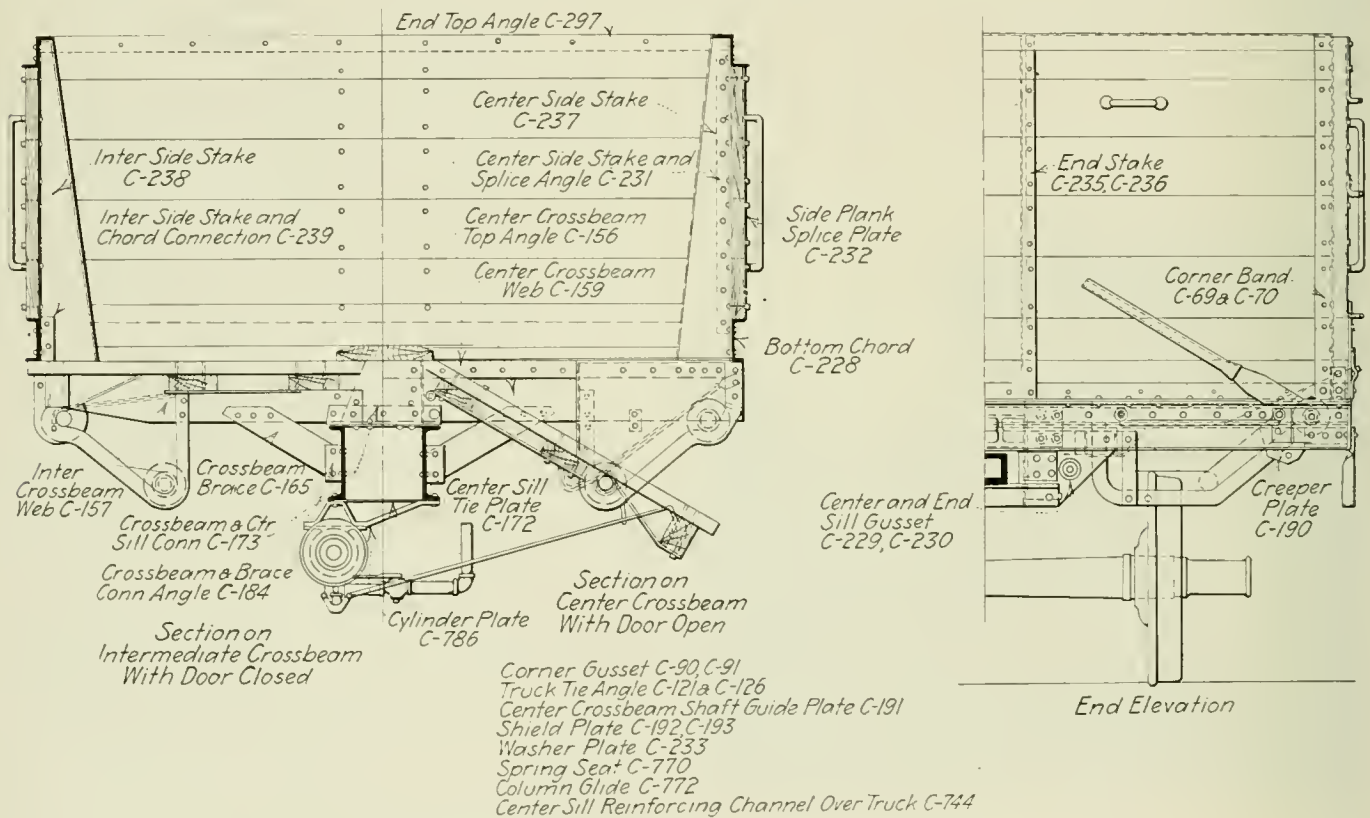

Fig. 3—Sample of Index Sheet for Steel Car Detail Book

and probably save the making of a loop that is not wanted. Arch bar drawings are made for the different series of cars. Each bar has a "B" number which can be painted on the finished bar.

In addition to forgings wooden pieces or parts which are frequently ordered are identified in the same manner, and box car doors have been standardized and identified, as shown in Fig. 2. In the line of standard practices betterment drawings are outlined and sent to all car foremen, in addition to a circular letter. Many railroads have made Shop Card files which cover some of the ideas outlined above, but this "B" book form permits of more ready binding and through the consecutive numbering shows each holder of a book whether or not he has all drawings or "B" numbers of all forgings and other car data.

In addition to the "B" or forging book, a steel car detail book has been drawn up, called the "C" book. Fig. 3, drawing No. 7159 C, shows the end elevation of a car which serves as an index sheet in the "C" book. Other drawings

of forgings seldom used to lay in stock and eventually find their way back to the scrap dock. The men readily remember the simple numbers of the pieces most frequently used and talk and work with those numbers. If these records are kept up to date, and it can readily be understood that they are useless unless they are, the storekeeper's troubles are greatly lessened, the car foreman's hunt for the right piece is as nothing compared with having no such record, and the railroad is constantly the gainer through the use of correct forgings and no more overstock of useless forgings.

**KEROSENE IN BEARINGS**—Kerosene oil has little or no lubricating property, but its use in bearings to remove gum and worn-out oil is an excellent practice provided it is flushed out with a liberal application of lubricating oil so that the bearings are left in a well lubricated condition to start. The fact that kerosene dissolves rust is no indication that it dissolves metal; it has little or no deteriorating effect on steel, brass, bronze or iron.—*Machinery*.





# T PASSENGER TERMINAL INSPECTION

The Relation of the Car Department to the Operation of a Large Passenger Terminal

BY R. S. MOUNCE

General Foreman Car Repairs, Erie Railroad, Jersey City, N. J.

The following article was awarded the first prize in the car terminal competition which closed April 1. The author in writing it has adhered strictly to practical cases, the description dealing with the terminal yard of the Erie Railroad at Jersey City. The second prize was awarded to J. E. Ross, master painter of the New Orleans, Mobile & Chicago. This article, together with others submitted in the competition, will be published in early issues.—EDITOR.]

The operation of the Jersey City passenger terminal of the Erie Railroad presents some unusual problems, mainly because of the nature and volume of the traffic handled in the limited space available. All movements follow a carefully planned schedule, and the mechanical and operating departments work in such close harmony that the combination forms a single well-rounded organization. The discussion which follows briefly outlines the method of preparation and the operation of passenger trains at this terminal

this statement it is seen that 89 per cent of all the trains operated are used in suburban traffic:

	Arrive	Depart
Through trains, Buffalo, Cleveland, Cincinnati & Chicago	4	4
Wells Fargo express trains, transcontinental	1	2
Milk trains	5	4
New York division trains	8	7
Suburban trains:		
Main line, proper	31	39
Main line, Newark branch	16	14
Northern R. R. of New Jersey	22	22
New Jersey and New York R. R.	20	20
Greenwood Lake division	26	26
New York, Susquehanna and Western	24	22
Total suburban trains	139	143
Total all services	157	160

Grand total, trains arriving and departing..... 317

The diagram shows the number of trains arriving at and departing from the station during each of the 24 hours. Between the hours of 7 and 10 a. m., 65 trains arrive and

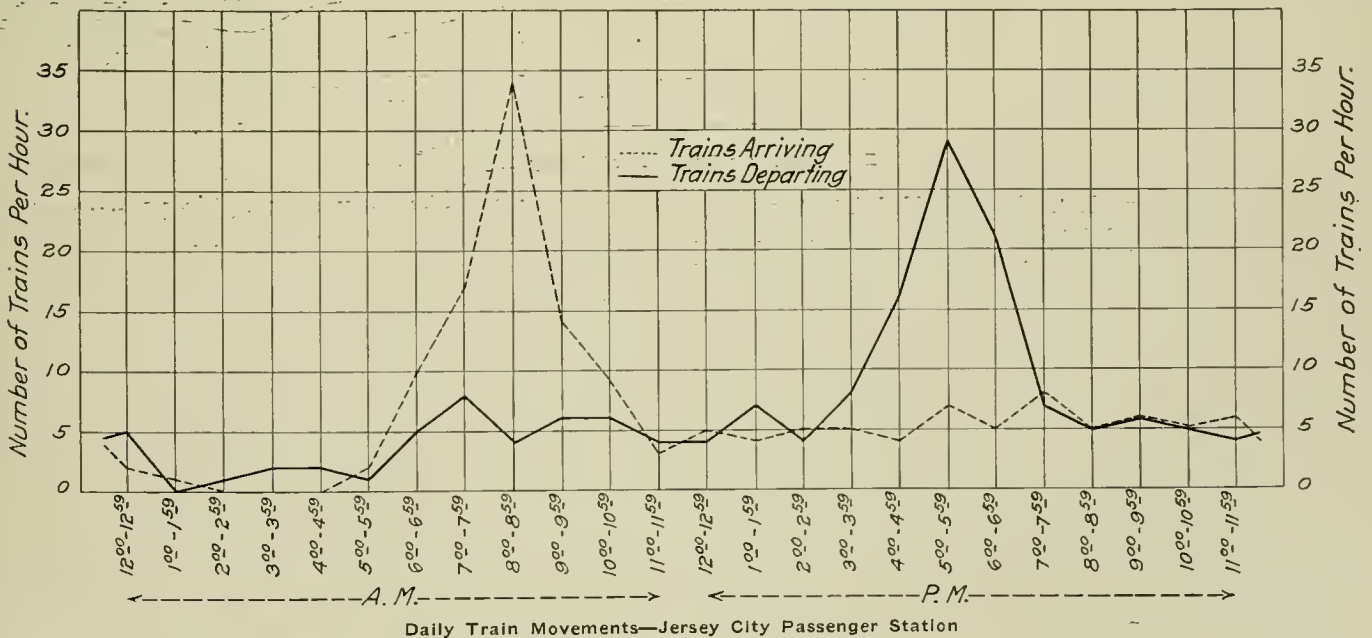

during the 24 hours of an ordinary week day in the winter season.

## NUMBER AND NATURE OF TRAINS

During a period of 24 hours a total of 317 regularly scheduled passenger trains arrive at and depart from the Erie station at Jersey City over the main line and four side lines according to the classification which follows. From

18 depart, and between 4 and 7 p. m., 66 depart and 16 arrive. Taking the trains out of the 12-track train shed to the various storage yards during the morning rush hours, and bringing them back again for the evening business without interrupting scheduled train movement, is a complicated problem which, from the nature of this discussion, cannot be described here.

The daily passenger train car movements out of the sta-

tion approximate more than 900, subdivided into the following classes:

Commuter coaches and combined cars.....	775
Through-line cars, including coaches, Pullman, dining baggage and mail cars.....	35
Through-line Wells Fargo express cars.....	20
Local express cars.....	30
Milk cars.....	50

The accompanying map shows the location of the several passenger car storage yards in relation to the station. Kelso street yard is located just north of the train shed so that a minimum amount of switching is required to place trains there. There are 70 trains handled in this yard during the 24 hours. The two Wells-Fargo trains are prepared and loaded on the Wells Fargo dock, which is adjacent to and north of the passenger station. Here also express cars for through line and local trains are handled. One short track at the head of the dock is used for the preparation of mail cars.

At Jersey avenue yard coaches, combined cars, diners and Pullman cars used on through line trains, as well as parlor cars and coaches for six local trains, receive the necessary attention. At the west end of this yard storage room is provided for extra coaches, Pullman and parlor cars. One portion of this end of the yard has an enclosed space with track room enough for the several business cars.

Monmouth street yard is located opposite Jersey avenue

required for these trains numbers about 300 persons, including supervision. All of this work comes under the direct charge of the general foreman car repairs, with a staff of several foremen. The station, Kelso street yard and the Wells-Fargo dock are looked after by one foreman with the aid of two assistant foremen, one of whom devotes his entire time to the express and mail cars, while the other attends to the station work and milk trains at night. Jersey avenue yard has one foreman, and Monmouth street yard has two, the one at the shop and the other in charge of the storage yard. All air brake inspectors at the several yards report directly to the yard foremen and indirectly to the air brake foreman, who gives the greater part of his time to the inspection and testing of brakes on trains arriving at and departing from the station. The foreman of electric car lighting has charge of all work on electrically lighted cars, including inspection and repairs to generators and storage batteries.

INSPECTION

All trains receive a running inspection while passing into the train shed, in order that flat wheels or any part which is dragging may be most easily detected. All through line trains, and commuter trains which remain there long enough are given a standing inspection before being taken to the layover yards. Any part found defective is marked with

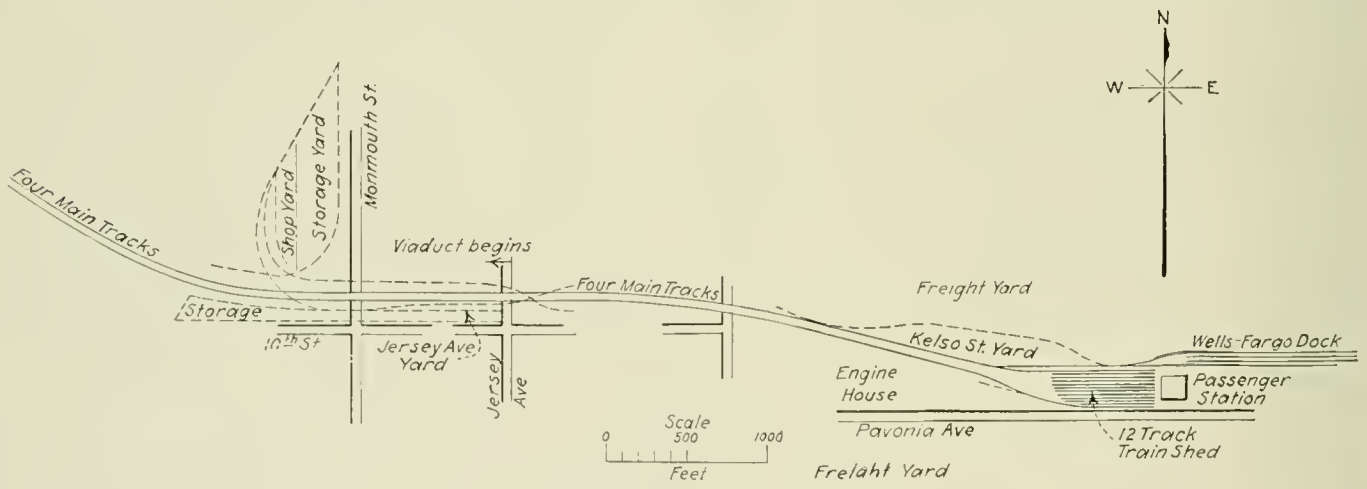

Erie Passenger Terminal at Jersey City

yard, north of the viaduct. It is divided into two parts, a shop yard with 5 tracks, and a storage yard with 19 tracks. There are 34 trains handled at the storage yard, the majority of them being placed there after the morning rush and remaining there until required for the heavy evening business.

The remaining trains, with the exception of milk trains, are handled by what are termed "relay" and "quick turn" movements, there being 23 "relay" and 17 "quick turn" trains. Immediately after a "relay" train reaches the station, its locomotive is uncoupled and moved a few feet away from the head car. Shortly afterward another locomotive backs down to the other end of the train and couples on ready for departure. After the arrival of a "quick turn" train, it is backed to the engine yard. The locomotive is then uncoupled and taken over the turntable, after which it is coupled to the other end of the train. The train then backs to the train shed and soon departs on its trip.

The four milk trains are loaded and prepared at the local freight yard south of Pavonia avenue. Three of them are afterward placed in the passenger train shed on account of their including coaches.

CAR DEPARTMENT ORGANIZATION

The force necessary to handle the inspection, maintenance, heating, lighting and cleaning of the passenger equipment

chalk and if the repairs will require several hours work or are of such a nature that the car will have to go over a wheel pit or be jacked up, shop marks are applied and the car is taken to Monmouth street shop. Minor repairs are made in Kelso street repair track or in the several storage yards. After trains are placed in the storage yards, a yard inspector goes over them again, locating any defects which were overlooked at the station. Express cars used on the Wells-Fargo trains, and mail cars are handled on the dock, where they receive most careful inspection on account of the exacting nature of these classes of service. Milk cars are inspected and minor repairs made in the freight yard.

The interiors of all coaches and combined cars are inspected daily by an experienced carpenter, who makes written report to the yard foremen regarding defects in seats, windows, deck sash, toilets, doors, steam heat appliances and any other defects reported by the train crews. Before departure from the station, all trains are given a standing air brake test by the air brake inspectors. At the same time air signals are tried and steam train lines examined.

MAINTENANCE

Minor repairs to all passenger cars are made in the storage yards by car repairers assigned to follow up the yard inspectors. Carpenters go through all trains taking care of work reported by the interior inspector and watching

for other defects which may have been previously overlooked. Air brake inspectors go over trains daily, examining air and steam train lines and hose, and cleaning cylinders and changing triple valves when they are out of date. They also make daily tests of brakes on all trains, adjusting piston travel when necessary, and trying the hand brakes periodically.

Heavy running repairs, such as change of wheels, journal boxes or pedestals; raising car bodies and other work requiring the use of jacks; platform, buffer or draft gear repairs; steam and air pipe work, and other similar repairs which will not hold the car out of service an undue length of time, are handled at Monmouth street shop. Cars requiring repairs of too extensive a nature for the somewhat limited facilities available are sent to the nearest general repair shop.

Through line, express and mail cars have all journals and journal bearings thoroughly inspected and the packing carefully examined and adjusted before each trip. All other cars receive this attention at regular and frequent periods.

#### HEATING AND LIGHTING

During the cold weather all trains, with the exception of certain cars held in the shop yard, are placed on steam while lying over in the yards. A power house, located just west of Monmouth street yard, equipped with three 500 hp. water tube boilers, supplies Monmouth street and Jersey avenue yards. Another power house, located near the station, furnishes steam for Kelso street yard, the Wells-Fargo dock and the station. Daily inspection of cars while under steam permits of keeping train line valves, steam hose and supply valves in good serviceable condition.

A large number of cars are lighted by Pintsch gas. All storage yards and the tram shed are provided with gas lines and connections, making it possible to supply gas to cars with but little trouble on account of switching. Gas checkers take readings of the gas gages on all cars and, in the case of local cars, if the pressure has dropped to a specified minimum, the reservoirs are charged to a certain maximum pressure. Through line cars are supplied with gas to the full line pressure every trip, regardless of the initial gage pressure. Regularly assigned men inspect and repair the gas lamps.

About 225 electrically lighted cars, in both through and local service, are operated. A portion of these cars in both classes of service are equipped with axle generators and the others with straight storage batteries.

Two inspectors go over the electric lighted cars on arrival, except in the case of axle light local cars which are inspected once daily regardless of the number of trips made. The first inspector reports all defects and replaces burned out or missing lamps and fuses. The second inspector reads the voltage on all cars, marking for charging those cars whose batteries are found with voltage at or below the specified minimum. All dining and mail cars are carefully inspected and repaired after arrival by electricians assigned to this work.

Storage battery cars which require charging are handled either at Jersey avenue or Monmouth street yards, where charging plants are located. Several pairs of tracks in each yard have third rails placed between them for carrying the charging current to the cars, connection being made from the third rail to the receptacle on the car. The current is returned to the charging plant through bonded service rails and underground cables. Two men operate each plant and charge the cars in the respective yards. These men are required to keep all cells flushed and to report defects in batteries or connections. Defective cells are located by electrolyte and voltmeter test. The repairing and cleaning of batteries is handled by a gang of four men, stationed at Monmouth street shop.

When the batteries of axle light cars require charging, the cars are taken to the western end of Jersey avenue yard, where a small charging machine and the electricians' shop are located. The periodic washing of batteries is looked after at this point.

#### CLEANING

About 140 car cleaners are required to take care of the cleaning of the equipment. Nearly all of this work, except the cleaning of relay trains, is done on a piece-work basis, insuring close adherence to time schedules, which is most necessary at a terminal when so many trains are handled. The sanitary condition of the cars is also a matter of prime importance.

All layover local coaches are swept and dusted; have their floors mopped with water containing disinfectant; toilet hoppers disinfected; lamps, globes and windows cleaned, and vestibules and hand rails cleaned, daily. Relay cars are swept, mopped and dusted after every trip, and held over at least once in ten days for a thorough cleaning of both interiors and exteriors. Exterior scrubbing of car bodies is given at regular intervals and dry wiping is done between scrubbing. Renovating interior woodwork, renovating plush seats, cleaning headlining, scrubbing toilets, scalding water coolers, and the vacuum cleaning of seats are operations which are performed periodically.

Through line coaches, Pullman, dining, parlor and mail cars are thoroughly cleaned both inside and outside after every trip. Certain of the above-mentioned periodic operations are not done so frequently.

The successful maintenance and operation of the equipment required to handle the large passenger business of the Erie Railroad in and out of its Jersey City terminal are the result of close co-operation and complete harmony, not only between the division operating officers and the local head of the car department, but also between the members of the car department staff. Close attention to the mechanical condition of the equipment and systematic care of every detail, bring about a reasonably satisfactory solution of a necessarily complex problem.

### THE SANITATION OF RAILWAY CARS\*

BY THOMAS R. CROWDER

Director of Sanitation and Surgery, The Pullman Company

One of the things through which disease is most readily transmitted by the indirect route is the common drinking cup. Infected lips leave bacteria on the rim, and well lips pick them up. Ten years ago the common cup was universal on railway trains; now it is a thing of the past. Thanks to the initial temerity of Kansas in 1907, a reform was started which has now become complete. The common towel was another very great evil. It has gone the way of the cup. The comb and brush, while less important, should be induced to make a similar exit.

Ample provision should be made in all railway cars for travelers to wash their hands and faces. Lavatories should be conveniently located, supplied with an abundance of water, well drained and trapped, and should have smooth surfaces for easy cleaning. Towels should be constantly at hand and in sufficient quantity for individual use. There should be a place for brushing the teeth—a dental lavatory—in all cars which make long journeys. Using a wash basin for this purpose is to make a cuspidor of it.

Toilets should be always available, well flushed, perfectly emptying, and capable of easy cleaning. The old type of open hopper, with its up-draught of wind and dust and its nearly constant fouling, is disagreeable, and its use is avoided to the detriment of the health of passengers. Cuspidors should be provided that spitting may not become an

\*From a paper read before the New York Railroad Club, April 21, 1916.

insanitary nuisance. The disinfection of toilets and cuspidors is largely esthetic, though it is often insisted upon by laws and regulations. What goes into them is well disposed of; it is not touched, cannot fly into the air, and does no harm unless it becomes a nuisance to sight or smell, when immediate remedies are demanded. The fallacious drip-machine—the so-called continuous disinfector—made so popular by the inspired commercial tongues of pseudo-scientists, should be mentioned only to be condemned. It does not disinfect; it only distils an odor, sometimes worse than the one it tries to hide, and diverts attention from conditions that need mending.

Day coaches should have cans for garbage and refuse. Not that garbage and refuse carry infectious diseases—that is one of the fallacies of popular thought—but particles of food and other rubbish may be picked up from a dirty floor by children, or from a cuspidor on which it lodges.

An ample supply of pure and wholesome drinking water should be supplied and stored in such a way that it cannot readily be contaminated by passengers. Ice that goes into the water should be also pure and clean and should not be handled with bare hands. Better yet, ice should not go into the water at all, but into a separate compartment of the cooler. Such an arrangement is now required by some of the states and is being carried out by numerous corporations where there is no regulation. It is standard on many railroads and in the Pullman service.

In addition to providing for the sanitary arrangements outlined above, the roads have another duty: to instruct their employees in the principles that govern the protection of public health, to make rules for their sanitary guidance, and to see that these are obeyed.

It is of course desirable that the railroads should take precautions to keep infection down to a minimum. This may be done in two ways: by mechanical cleaning which removes the bacteria, and by fumigation which kills them. Of the two methods, the former is much the more important. Mechanical cleaning will not remove all the bacteria—for it cannot remove the last particle of dust and dirt in which the bacteria are contained—but if it is well done not enough will remain to hold out any danger to passengers.

The method used in the cleaning of cars is of less importance than the result obtained, which must be reasonable cleanliness in all instances. For bare floors, toilets, woodwork and utensils, soap, water, and elbow-work are the important ingredients which must enter into the process. For dislodging dust from corners and angles an air blast is both rapid and efficient. For removing it from carpets and fabrics the vacuum process is best; it not only removes the dust but collects it for final and quick disposal instead of scattering it about. But vacuum cleaning without sufficient power is a makeshift. Some two years ago, as a member of a committee to investigate car cleaning, I went through this subject in an experimental way. In the beginning there was no vacuum machine on the market which was well adapted to the work in car cleaning yards, but one was soon developed which did better cleaning than the compressed air process and did it cheaper, as has been amply verified by two years of practical application in Pullman service.

Fumigation is a procedure which has been much overworked in the past. Ten years ago there was an epidemic of state Board of Health regulations requiring it at frequent periodic intervals. If properly carried out, there is no doubt that fumigation will kill the vast majority of the bacteria in a car; but it is not a proper substitute for thorough mechanical cleaning, after which not enough bacteria will remain to be of any real hygienic significance. In recognition of this fact the movement for periodic fumigation is now dying out: the tendency is rather to require it only after serious infectious diseases are known to have been carried, as is done by the new Interstate Quarantine Code. No objection

should be made to that demand, even though the good it does is questionable and problematic.

Ventilation is a vital sanitary problem. Good air is of prime importance to good health. Ten or twelve years ago, attempts to supply good air to railway cars were generally failures. The problem seemed complicated and almost hopeless. It still has its difficult points, but thanks to the enlightening research of the last ten years it is now much simplified. We have learned what good air is: it is air that bears a proper thermic relation to the body. It must be able to absorb the body heat as rapidly as formed, without being cold enough to produce chilling. It must be warm, but not too warm; it must have motion, but not enough to cause discomfort; it must be changed constantly to prevent stagnation and overheating. The chemical changes brought about by respiration are ordinarily negligible.

Due to the high wind pressure to which running trains are constantly subjected, a surprising amount of air enters them even when no special provision is made for it. I believe the quantity can always be kept adequate by the application of a simple exhaust system, as is now done on many lines. A more difficult problem than maintaining the air supply is the proper control of heat. If the temperature is carefully regulated to between 65 and 70 deg. F., complaint of poor ventilation will rarely arise, even with impure air and a very small supply. Above 70, trouble comes quickly; we think there is not enough air to keep our lungs flushed out. That is not the trouble at all, for let the air supply remain the same and the temperature drop to the lower sixties and we think there is too much. The income and the outgo create air motion within. When the temperature is high we need more motion, hence a larger air supply, to keep the body cool; when it is low we need less motion, or a lower air supply, to keep the body warm. But the lungs and the function of respiration have nothing to do with this; it is entirely a surface function; and that is what ventilation is for—to act on the surface of the body and carry away its heat.

With a simple exhaust system of ventilation, specific air inlets are not necessary unless cars are greatly crowded. Natural crevices, to which may be added open sashes in the end doors, will be sufficient. For supplying artificial heat, direct radiation is better than indirect. Little cold streams of incoming air, mixing with the warmer and stiller body of air within, contribute to the stimulating variations of surface environment which are necessary to comfort and health. Only when large quantities of cold air are admitted at one place is heating of the incoming stream desirable, and this is not a good plan for ventilating railway cars. When no artificial heat is needed, as in the warm summer months, nothing can take the place of open windows; for large streams of rapidly moving air are necessary to maintain the thermic balance of the body.

A certain amount of dust, smoke and engine gases inevitably enters cars. They are, of course, liable to great variation. Smoke and gases are never troublesome except in passing tunnels, when they produce no more than temporary discomfort. I have examined many specimens of tunnel air and have found the gases of combustion always far below the point of danger. Ordinarily only the heavier particles of smoke—the small cinders—enter the car, the lighter solid particles and gases floating up and away with the wind.

Ordinary dust is of more importance because it is more prevalent and because it is possibly infectious. If not infectious it is at least irritating and uncomfortable, and prolonged breathing of a heavily dust-laden air predisposes to infections of the respiratory tract. Its sources from within the car should be limited by good cleaning, which is now generally satisfactory. When this is well done, carpets and plush are better than bare floors and smooth upholstery because they hold the dust that settles on them and prevent its redistribution to the air of the car.

# NORTHERN PACIFIC EXPRESS CARS

Designed for the Transportation of Perishable Freight in Both Passenger and Freight Service



Northern Pacific Refrigerator Express Car

THE Northern Pacific is called upon to transport large quantities of berries, cherries and other fruit from the states of Washington, Idaho and Oregon, to many distant inland cities, the cherries being shipped as far East as New York, Boston and Philadelphia. A considerable amount of fresh fish obtained from the fisheries in the Northern Pacific and Alaskan waters is also transported to inland

head end of the train, which made it advisable that the strength of the underframe be equivalent to the United States railway mail service requirements for steel postal cars. It was also necessary to apply a spring buffing arrangement, which, when the cars are used in freight service, can be easily and quickly taken out of service. These cars have a light weight of 74,700 lb. and have a capacity of 70,000 lb.,

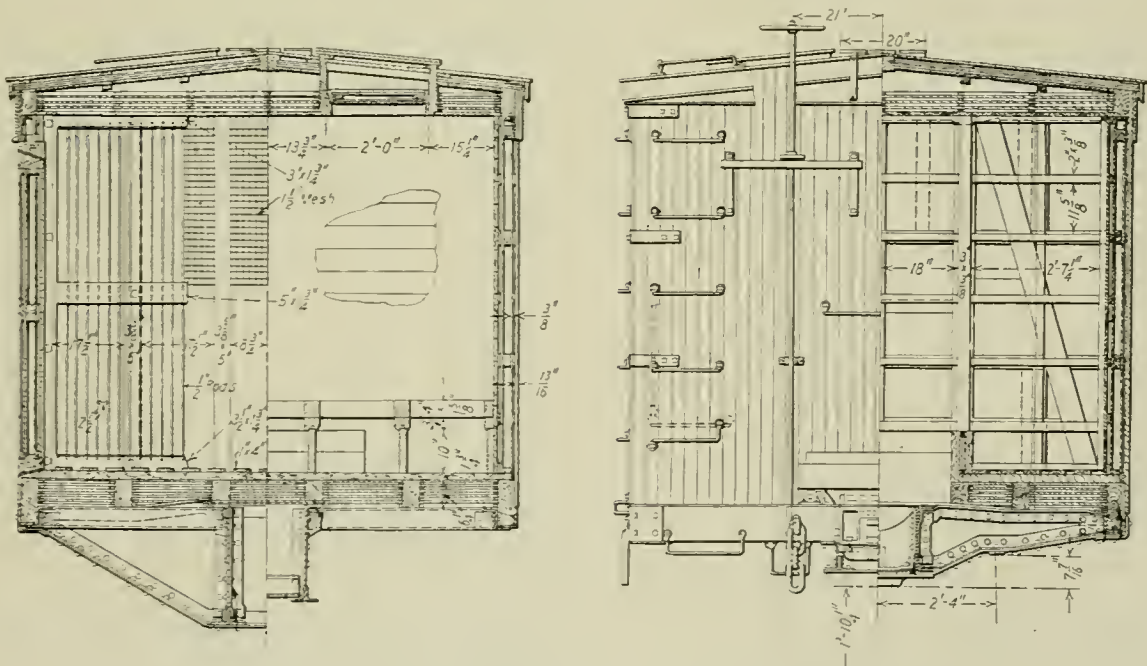

Cross Sections of the Northern Pacific Express Refrigerator Car

and Eastern points. In order to insure prompt and expeditious delivery at such distant points special passenger refrigerator cars are required. Forty of these cars, which have given very satisfactory service as refrigerators and as cars were built for this road by the Pressed Steel Car Company from the designs and specifications of the railway company. The cars were designed to be used in both passenger and freight service and have some interesting features of construction.

When used in passenger service they are placed at the

including 10,000 lb. of ice. The following are their principal dimensions:

Length over sub-end sills.....	42 ft.
Length inside .....	41 ft. 2 1/8 in.
Length inside, between ice boxes.....	34 ft. 3 1/2 in.
Width inside .....	8 ft. 10 in.
Distance between floor and ceiling.....	6 ft. 11 in.
Bolster centers .....	32 ft.
Top of rail to top of running board.....	12 ft. 2 3/4 in.
Width over sheathing.....	9 ft. 9 3/8 in.

The cars are designed to pass safely over curves of 150



ft. radius, and are built to conform to the New York City electric zone clearances and the American Railway Association's clearance for third rails. They are designed to carry a live load of 70,000 lb. plus 10 per cent overload in addi-

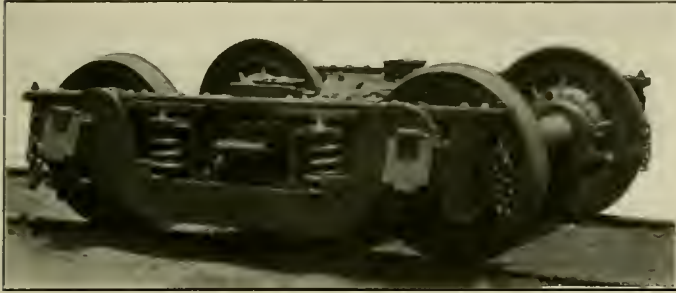

Four-Wheel Truck for the Northern Pacific Express Cars

tion to the dead weight plus the usual 50 per cent allowance for shocks and oscillations. The steel underframe is similar to that used on the 60-ft. steel postal cars in use on that road

by 7/16-in. angles at the bottom (inside and outside), 3 1/2-in. by 3 1/2-in. by 7/16-in. angles at the top on the outside, one 26-in. by 1/4-in. cover plate extending from end sill to end sill, and one 26-in. by 7/16-in. cover plate extending from bolster to bolster. The center sills are 15 1/2 in. deep at the bolsters. The side sills are composed of one 5-in., 11 6-lb. Z-bar and one 5-in. by 4-in. by 3/8-in. angle. The bolsters and cross-bearers are of the built-up type consisting of web plates reinforced by angles at the top and bottom and by cover plates. The platform end sills are composed of channel sections with cover plates at the top and bottom. The car body is of wooden construction consisting of 5-in. by 6-in. oak door posts, 5-in. by 5 3/4-in. oak corner posts, 2-in. by 5-in. fir side posts, 2-in. by 5-in. oak end posts, and 2-in. by 5-in. fir side and end braces. There are two 2-in. by 3-in. belt rails, and eighteen 1 3/4-in. by 10 1/2-in. carlines.

The arrangement of the buffing device is shown in the accompanying drawings. The buffing springs are encased in a cast steel housing which is held in either the "in" or "out" position by toggle bolts fitting in the lugs at the cor-

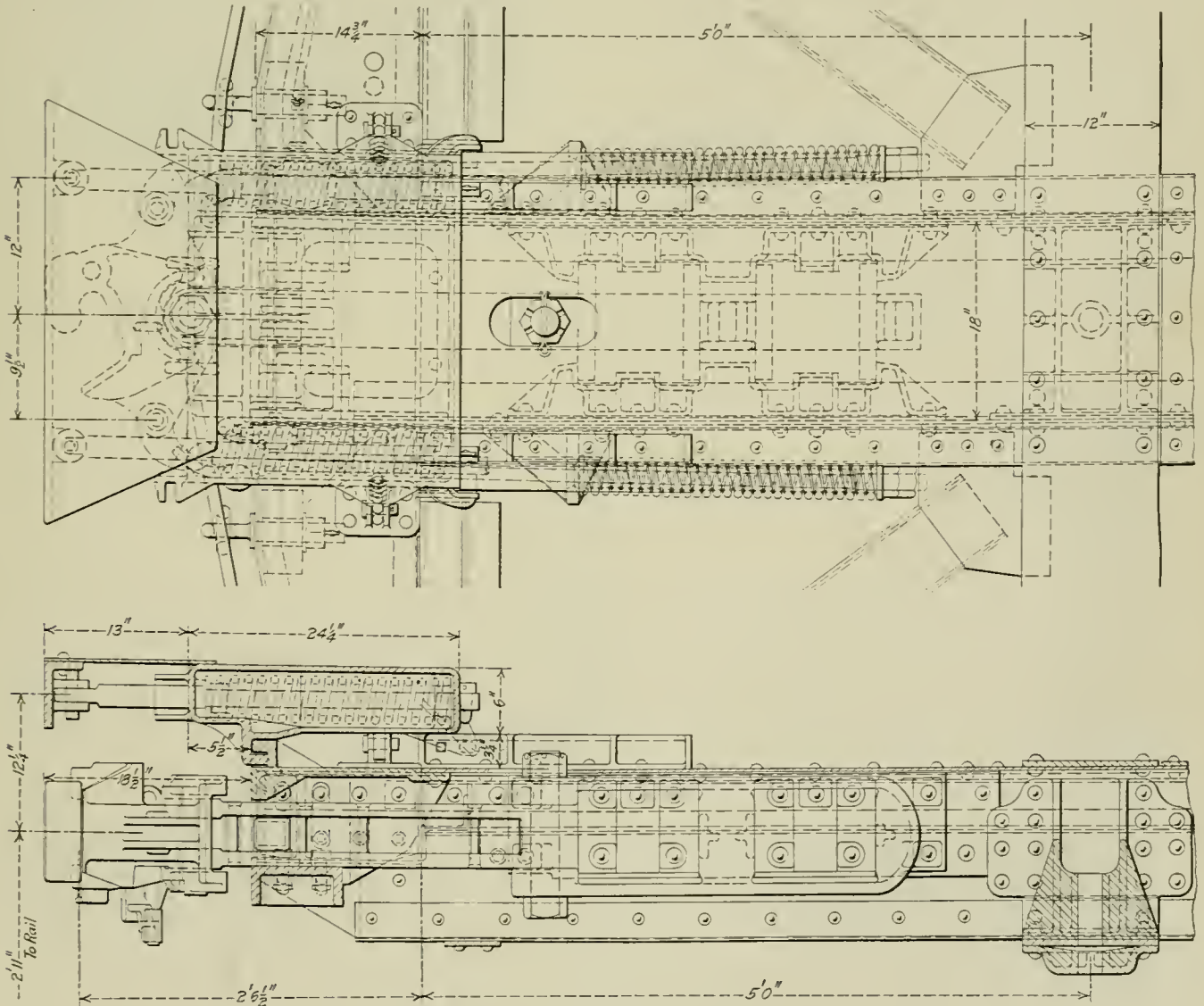

Application of the Buffer and Draft Gear

and is designed to withstand a buffing shock of 400,000 lb. applied as a static load.

The center sills are of the fishbelly type, 28 in. deep at the center. They are composed of 5/16 in. vertical web plates located 18 in. back to back with 3 1/2-in. by 3 1/2-in.

ners of the housing. When in the "out" position the thrust on the buffer is transferred to the draft gear housing by means of interlocking lugs cast on both the buffer and draft gear housings, as shown directly underneath the front of the buffer housing. When in the "in" position the buffer hous-

ing rests on a bed plate and is well inside of the car in a recess built under the ice grates, as shown in the sectional elevation. A sliding door is provided on the end of the car to cover the recess when the buffer is in the "in" position. The time consumed for changing the buffer from one position to the other, either for freight or passenger service, is from 10 to 15 minutes.

Sectional air space insulation for the walls, floor and roof is similar to that of the freight refrigerator cars built for this road in 1913. The accompanying table gives a detailed description of the insulation construction (from the inside of the car in the order shown).

INSULATION

FLOOR	WALLS	ROOF
1 3/4-in. flooring	13/16-in. lining	13/16-in. ceiling
90-lb. Neponset paper	90-lb. Neponset paper	90-lb. Neponset paper
1 1/2-lb. wool felt	1 1/2-lb. wool felt	1 1/2-lb. wool felt
3/8-in. ship lap	3/8-in. air space*	Air space
1/2-in. air space	1 1/2-lb. wool felt	3/8-in. ship lap
90-lb. Neponset paper	90-lb. Neponset paper	90-lb. Neponset paper
1 1/2-lb. wool felt	3/8-in. ship lap	1 1/2-lb. wool felt
3/8-in. ship lap	2-in. air space	Air space
1/2-in. air space	3/8-in. ship lap	3/8-in. ship lap
1 1/2-lb. wool felt	90-lb. Neponset paper	1 1/2-lb. wool felt
90-lb. Neponset paper	1 1/2-lb. wool felt	90-lb. Neponset paper
3/8-in. ship lap	3/8-in. air space*	Air space
1/2-in. air space	1 1/2-lb. wool felt	3/8-in. ship lap
1 1/2-lb. wool felt	90-lb. Neponset paper	1 1/2-lb. wool felt
90-lb. Neponset paper	13/16-in. sheathing	90-lb. Neponset paper
3/8-in. ship lap		Air space
1/2-in. air space		5/8-in. sub roof
1 1/2-lb. wool felt		90-lb. Neponset paper
90-lb. Neponset paper		Paroid plastic roofing
3/4-in. dead floor		Sub-carlines, 9/16 in.
		Sub-purlins, 7/8 in.
		13/16-in. roofing

\*In the 3/8-in. air spaces in the walls vertical and horizontal flat wooden strips 3/8 in. thick are provided to cut up this air space into small sections, thus making these air spaces as near "dead" as they can be made by the careful fitting of wood to wood. In addition, these strips serve to hold the wool felt in place.

There is an ice box at each end of the car having an ice capacity of 5,000 lb. The Bohn syphon type fixed bulk-head is used. In addition to the usual ice pan drainage,

are used wherever practicable. The railway company's standard four wheel equalized trucks are used, having a wheel base of 6 ft. 6 in. and 5 1/2 in. by 10-in. M. C. B.



End View, Showing the Buffer Arrangement

journals. The bolsters are steel castings and the spring planks are made up of two 6-in. by 4-in. by 3/8-in. angle

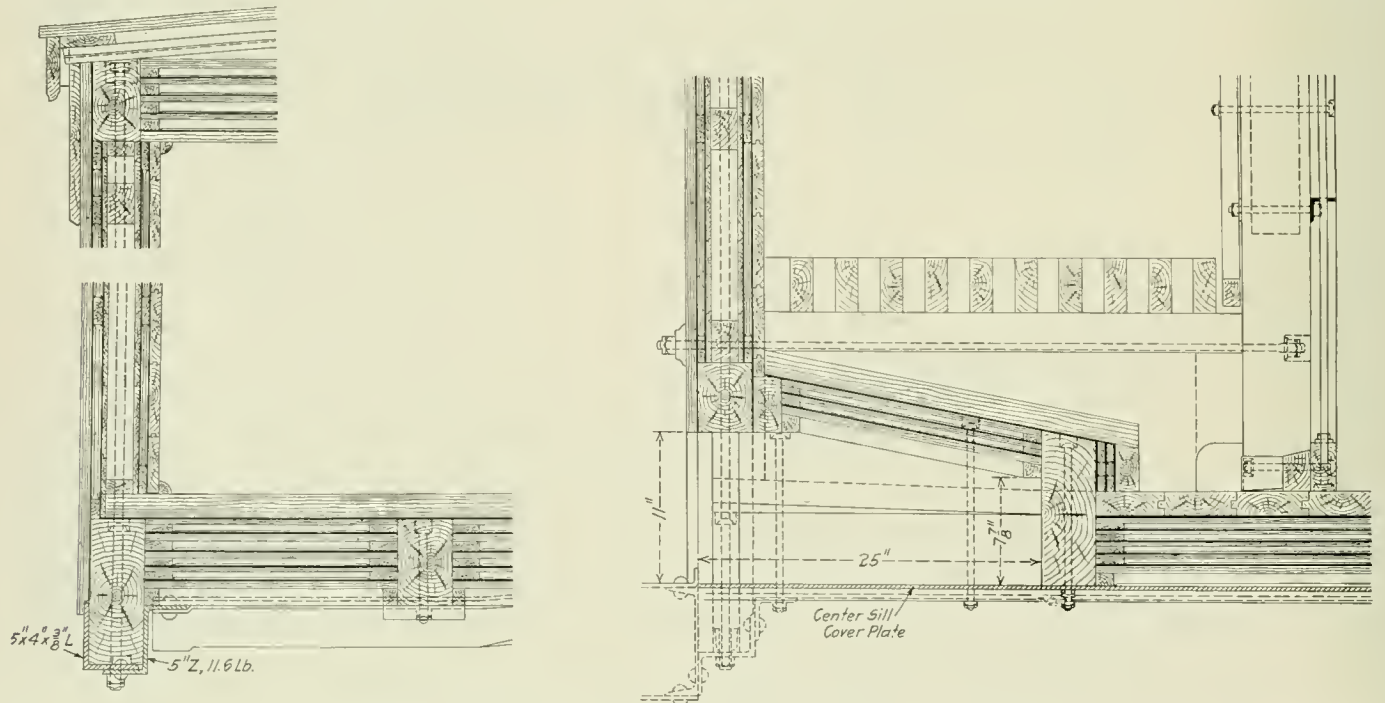

Sections Through Side, Roof, End and Floor, Showing Recess for Buffer

drainage is also provided for the floor. The Miner tandem spring draft gear is used with one M. C. B. class G and one 8 in. by 8 in. Harvey friction draft spring in each gear. The cars are provided with the Westinghouse schedule LN-1412 air brakes. Cast steel parts, instead of forgings

bars. The bolster springs are triple elliptic and the equalizer springs are coil springs of the M. C. B. standard class G. The wheels are 34 1/4 in. in diameter with 3 1/8-in. steel tires. The brake beams are of the Davis high speed solid truss type.



THE CAUSE OF SLID FLAT WHEELS\*

The relation of slid flat wheels to uniform retardation, or rather the lack of it, is not generally apparent. In the first place it is well to review the influence of adhesion or wheel-rail friction on the braking problem. Fig. 1 shows a locomotive driver with the crank pin on the top quarter and the force applied by a horizontal cylinder with a main rod of infinite length. As long as the wheel doesn't slip, it is evident that the wheel moves about the point of contact of the wheel with the rail as fulcrum. A line joining the crank pin with this fulcrum point may be considered as a simple lever of the second class. The delivered force appears at the center of the wheel and is the force which moves the train. Strictly the net force serving to move the train is the difference between the delivered and applied forces, because the reaction of the steam acting against the back cylinder head is exactly equal and opposite to the applied force on the piston and is applied through the locomotive frame to the center of the wheel and directly opposes the delivered force. This difference between the two forces sets up a thrust of the wheel to the left against the rail, which thrust is equal, of course, to the force difference causing it. This thrust of the wheel on the rail is exactly equaled and opposed by the thrust of the rail on the wheel. That is, action and reaction are always equal and opposite. With reference to the ground this thrust of the rail on the wheel is the force which, applied from a point external to the locomotive, moves it. *If this is only remembered it will be easy to visualize the effect of the*

engine the pin is still on the quarter. The lever now becomes instead of the straight line lever of Fig. 1, an offset lever; otherwise Figs. 1 and 2 are much the same. Were the crank pin shifted to the tread of the wheel the engine stroke would equal the wheel diameter and the same applied force would be much more effective in moving the train. The lever would now be a 1 to 1 lever; that is, the power arm and weight arm would be equal.

That is just the condition of affairs in Fig. 3. The applied force is the force of friction of the brake shoe, applied at the tread of the wheel, and this is a 1 to 1 offset lever with the fulcrum at the point of contact of wheel with rail. The delivered force at the center of the wheel opposes the motion of the train. It is equal to the applied force, which, in turn, is equal to the braking ratio (actual) times the weight on the wheel times the coefficient of brake shoe friction. It is also equal to and agrees in direction with the thrust of the rail on the wheel. As before noted, this is limited in value by the adhesion between wheel and rail.

If a car in motion and with the brakes applied suffers impact in a direction such that the car is accelerated, the rotative speed of the wheels will be increased also. But to accelerate the wheels a certain thrust is required from or of the rail. This is in addition to the thrust caused by brake shoe friction. If the sum of the two thrusts exceeds the adhesion the wheel will slide. The impact lasts a very short time only, and the rail thrust brought into play by this impact lasts only as long. But brake shoe friction in this very short interval of time has jumped up in value, becoming static where

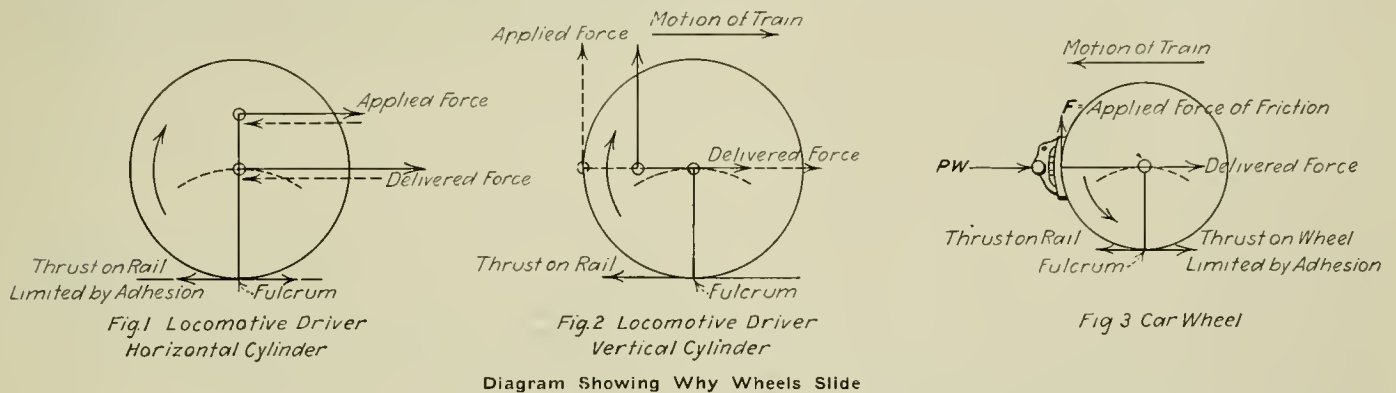

rail on the train when the brakes are applied. Now, if the locomotive be reversed, which means also reversing the forces, as indicated by the dotted lines, a retarding force is set up and finally applied by the rail to the wheel in a direction opposed to the motion of the train, according to the sequence above pointed out.

Plainly, if the fulcrum, or point of purchase, at the contact of the wheel with the rail, should fail, the drivers will slip and the train fail to move—or at least fail to be accelerated except for an amount equal to the kinetic friction, or friction of relative movement, between wheel and rail. The value of this kinetic friction is far less than the static or rolling friction, which is most frequently termed "adhesion." This failure of the fulcrum occurs when the thrust of the wheel on the rail exceeds the adhesion between the wheel and the rail. This adhesion is generally taken as 25 per cent of the weight resting on the rail. With a good dry condition of tread and rail surfaces 30 or 35 per cent may be the limiting value, and, on the other hand, the adhesion may drop to 15 per cent or less if the surfaces are slippery, due to frost, etc.

Now consider Fig. 2. The crank pin has been shifted 90 deg. and the cylinder placed vertically, something like a walking beam engine for a river boat. With reference to the

it was kinetic before, and the wheel-rail friction has dropped in value, becoming kinetic where it was static or rolling before and the wheel continues to slide. In other words, the impact has "knocked the car off its feet" and brake shoe friction keeps it "off its feet."

However, even though the car is knocked off its feet and thus the wheels slide momentarily, it doesn't always follow that they will continue to slide. For if the pull of the rail with the wheel sliding exceeds the pull of the shoe, the wheel will commence to rotate again and so continue. This statement will help to nail the fallacy that once a wheel starts to slide it will *always* continue to slide; and, also, that a wheel can be slid from a standstill with a low cylinder pressure. To slide the wheel from a standstill, or to keep a car off its feet, once it has been knocked therefrom, either the cylinder pressure must be high or the rail bad, or both. The assumption made in the analysis appearing on Plate 2 is a cylinder pressure of 34 lb. and a drop in wheel-rail friction from 25 per cent to 10 per cent and a rise in shoe-wheel friction from 15 per cent to 30 per cent. With a loaded car the cylinder pressure will have to be *very* high and the rail *very* bad before the wheels can be slid from a standstill or will continue to slide after a shock has knocked the car off its feet. That is, slid flat wheels appear on empty cars much more frequently than on loaded. The cylinder pressure or rail condition necessary to keep wheels sliding on passenger cars is

\*Abstracted from a paper on the Empty and Load Freight Brake presented at the February meeting of the St. Louis Railway Club by Walter V. Turner, assistant manager, Westinghouse Air Brake Company.

much less extreme in value, due to the use of a much higher braking ratio than on freight cars.

An impact opposed in direction to the motion of the train can effect the same result if it be enough greater, other things being equal, to neutralize the rail thrust set up by brake shoe friction and carry in the opposite direction beyond the limit of wheel adhesion. The wheel once stopped in rotation, be it but for an instant, is readily "locked" by the brake shoe as pointed out above, and it continues to slide, provided the brake shoe friction exceeds the wheel-rail friction.

For example: A freight car weighing 50,000 lb. has an adhesion of 3,125 lb. per pair of wheels, if the factor of adhesion is 25 per cent. A 15-lb. brake pipe reduction gives 690 lb. brake shoe friction for 60 per cent braking ratio on 50-lb. cylinder pressure, 85 per cent brake rigging efficiency and 15 per cent brake shoe friction. An impact of 200,000 lb. will bring the total rail thrust up to the above adhesion limitation. If the braking force is greater, the impact greater (not unusual in service), or the adhesion less, the car will be "knocked off its feet." If the brake shoe friction at this instant exceeds the wheel-rail friction the car will be held "off its feet." This will be true if the rail friction drops to 10 per cent (1,250 lb.) and the shoe friction rises to 30 per cent (1,380 lb.), due to the change from static to kinetic friction and vice versa, respectively. Under the same conditions an impact in the opposite direction must exceed 300,000 lb. to knock the car off its feet. The impact computation is based on two 700-lb. wheels and a 500-lb. axle having a moment of inertia of 143.

Thus it is obvious how prolific in slid flat wheels may be shocks due to the lack of uniformity in braking.

## SYSTEMATIC REPAIRS TO FREIGHT EQUIPMENT

BY F. G. LISTER

Mechanical Engineer, El Paso & Southwestern, El Paso, Texas

On a railroad system where it is the practice to make extensive repairs to a series of freight cars of the same kind, or where a large number of new cars of one type are being built, a systematic arrangement of the work is of the utmost importance in order to keep costs as low as possible and not keep the cars out of service any longer than is absolutely necessary.

The El Paso & Southwestern system has arranged an organization at the El Paso shops which it is believed brings the cost of repairs down to the minimum. The organization consists of a number of gangs of men, each gang having a special line of work to perform in a given length of time. The number of men in each gang depends altogether on the class of work to be done. An example of this organization is outlined below for a series of 50-ton box cars which were recently put through the shops and rebuilt. The required output was one car every five hours with a gang of 27 men, and the number of gangs, and men in each gang, were arranged accordingly. This, of course, means that each gang must perform its particular work on each car in the five hours.

*Gang No. 1.*—Remove trucks and apply temporary trucks. Send trucks to truck repair track or shop for required repairs. Strip car of all appliances that are to be removed.

*Gang No. 2.*—Remove tie rods, broken or decayed posts, and other defective parts. Clean out all post pockets.

*Gang No. 3.*—Repair steel underframe.

*Gang No. 4.*—Apply posts, side and end plates, belt rails, cripples, ridge poles, carlines, grain strips, side sill nailing strips, decking, tie rods, and square up car.

*Gang No. 5.*—Apply all lining, siding and roof sheath-

ing. Apply side and end door tracks, guides, stops, threshold plates, etc.

*Gang No. 6.*—Make or repair side and end doors, latitudinal running boards, etc.

*Gang No. 7.*—Apply roof, fascia, running boards, and safety appliances, hang side and end doors, apply brake staffs and foot boards.

*Gang No. 8.*—Repair trucks and apply them at this point in the line. Repair draft gear.

*Gang No. 9.*—Apply first coat of paint (eight hours to dry); apply second coat of paint (eight hours to dry).

*Gang No. 10.*—Stencil. Car O.K.

In organizing a gang for making repairs as outlined above, there must first be ascertained the required output of O.K. cars per day, then a unit of work or schedule of operation established, each operation of which must be completed in a stated time. If it is desired to turn out a car every 30 min., the operation must be manned sufficiently, and the operations must be what every man or gang of men can do in that time. A 30 min. schedule on a steel underframe box car similar to the above series of cars would require about 80 men, and from 16 to 20 operations, on which would show a labor cost of about \$12.00 per car if the average wage does not exceed 30 cents per hour. Of course, mill labor would be a separate item, as there are very few mills capable of handling material this fast. Therefore, material for the entire output of cars must be accumulated in advance.

The man assigned to the work of organizing the gangs for this work must have a thorough knowledge of what a man or gang of men is capable of doing in a given length of time. Upon this hinges the success or failure of the plan. At the end of each 30 min., or whatever period is decided upon for each operation, each gang moves each car ahead one car length, which will turn out a car O.K. every 30 min. It is imperative that the entire line move promptly at the end of the required period of time.

Just before the car goes to the painter, two or three men, known as the "OK" gang, go over the car and finish anything that may have been left uncompleted by some one of the other gangs at the expiration of their work period. By watching at this point for uncompleted work the incompetent workmen can be traced and weeded out, as every man does the same work on every car handled. Anything he leaves undone shows up when the inspector goes over the finished car.

By specializing the work in this way each man in a very short time becomes an expert in his particular operation, and it is surprising how each gang watches the gang ahead and behind to see that they are not through first. Of course, if one gang stops or lags, the entire line will be held up. But if the man in charge is alert and keeps in close touch with his gangs and what they are doing, he will see to it that not a single operation fails after the first eight or ten cars are put through.

In order that work on the roof and upper part of the body may move rapidly, a scaffold should be built on each side of the repair track the length of the line. It is necessary that a sufficient number of cars be on hand and that they be lined up on a track open at each end. Sufficient material should be gotten out before the cars begin to move so that there will be no possible chance of the gangs being held up. For the second coat of paint and stenciling, the cars may be moved to a separate track.

After the work is started and is in full swing, a piece work price would be placed on each operation, and will give the men performing the operation, each a fair day's wages. This price, when it has once been established, makes the cost per car, under all conditions, the same for every car that is turned out.

# SHOP PRACTICE

## INTERESTING BOILER SHOP DEVICES

The following four devices in use in the boiler shop of the Elgin, Joliet & Eastern at Joliet, Ill., have been found useful in making repairs to locomotive boilers. Fig. 1 shows

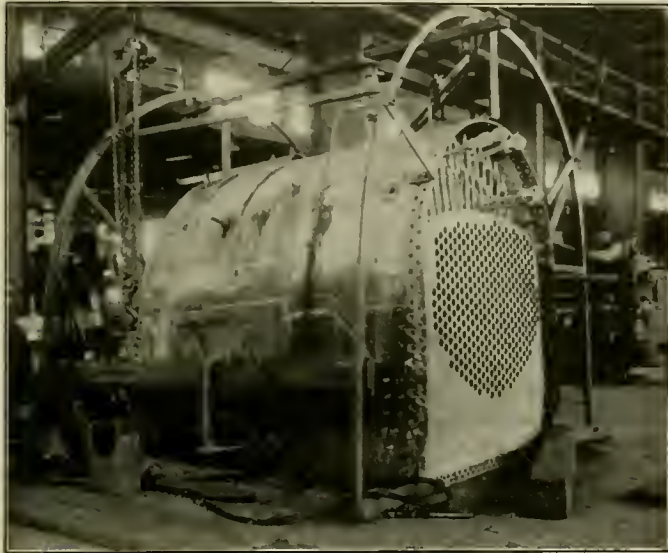

Fig. 1—Jig for Drilling Holes in Firebox Wrapper Sheets

a frame surrounding a firebox for the purpose of backing up air drills, reamers and the like, used in drilling the wrapper sheets. It consists of a frame work of angle iron bent

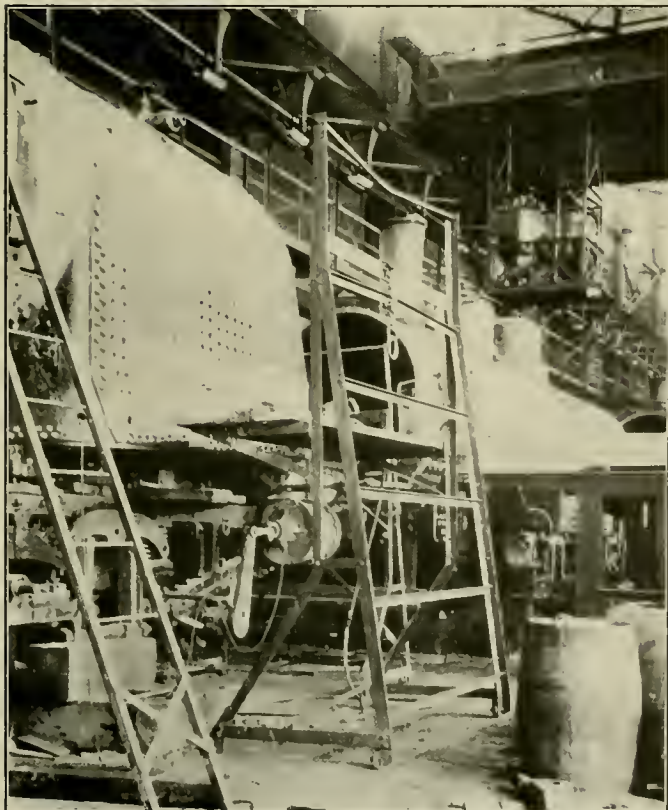

Fig. 2—Portable Scaffold for Boiler Work

to conform to the shape of the firebox, supported by tie bars extending out from the boiler, as indicated in the illustration. The two angle forms are tied together by heavy planks

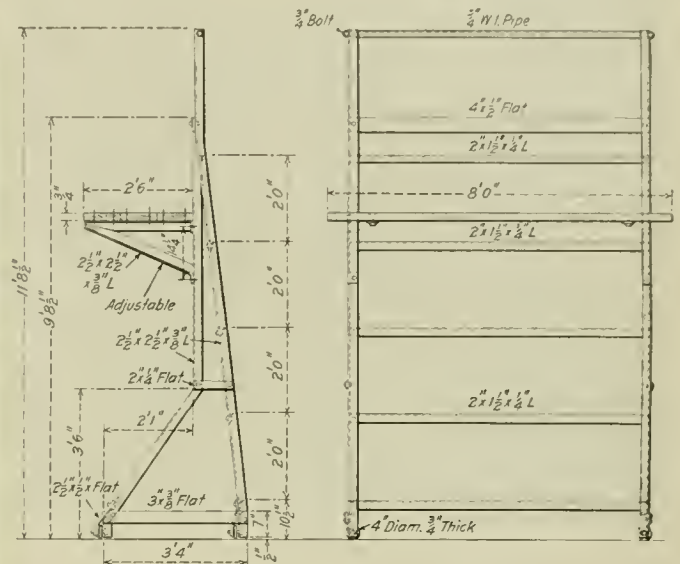

Fig. 3—Portable Scaffold for Boiler Work

which are adjustable on the bars and serve as back rests for the air motor.

Figs. 2 and 3 show a portable scaffold for use in working on the boilers. As indicated in the sketch, it is made up of angle iron and supported on small wheels so that it can be easily shifted from one part of the engine to the other. In moving it about the shop it is handled by the overhead crane. The scaffold may be adjusted to any height, bolt

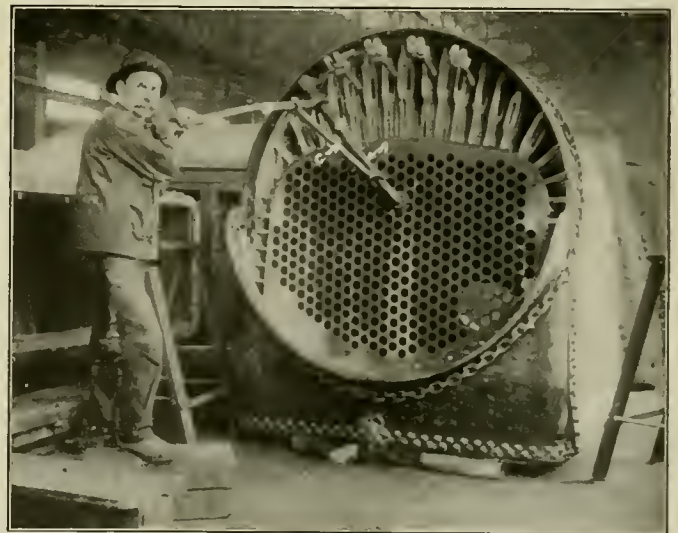

Fig. 4—Holder-On for Riveting the Boiler Barrel to the Wrapper Sheet

holes being provided in one leg of the vertical angles for securing it to the frame work. At the top there is a rail between the two uprights, which prevents the men from falling when the platform is raised to the top of the scaffold.

Fig. 3 shows the method used for backing up the rivet

hammers when riveting the boiler barrel to the firebox, the helper, of course, being inside the barrel instead of on the floor, as indicated in the illustration. This device consists of a rod *A*, which is bent and threaded for a nut at the tube-sheet end in order to hold it in the tube sheet. The anvil is mounted on the tubing *B*, which slides on the rod *A*. The truss rod *C* is hinged to both the rod *A* and the lever *D*, and forms the fulcrum for the lever. The weight of a helper on

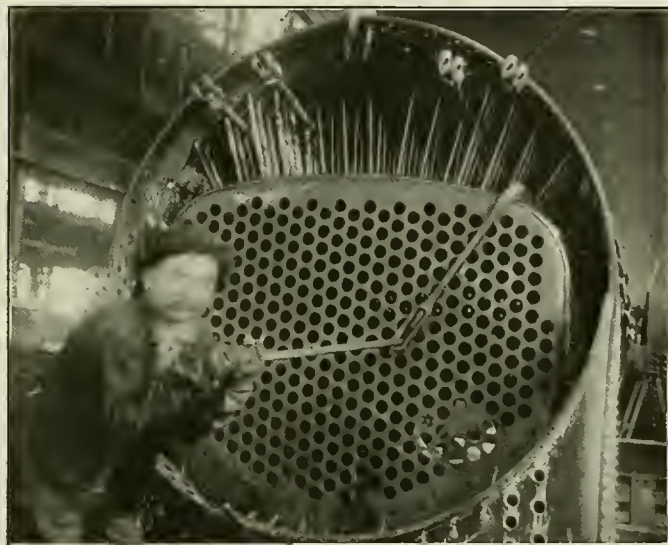

Fig. 5—Holder-On for Riveting Tube Sheets to the Crown and Side Sheets

the end of the lever arm *D* forces the anvil out against the sheet, providing a substantial backup for the riveter.

Fig. 5 shows a similar device for riveting tube sheets into the firebox sheet. In this case, as before, the helper is on the inside of the boiler and putting his weight on the lever brings the anvil hard down on the crown sheet. The end of the anvil rod is equipped with a turn buckle so its length may be readily adjusted. The other end of the lever arm is simply placed in one of the holes in the tube sheet.

## EFFICIENCY IN SCHEMING

BY RUSSELL R. CLARKE

Assistant Foreman, Brass Foundry, Pennsylvania Lines, Pittsburgh, Pa.

All industrial service improves with quality and congenial personality of workmen, suggesting the advantage of a plan to differentiate in choosing men. Manners, intelligence, principles, record and experience can be drawn out by casual conversation in sizing up the applicant. A record of constant change means something, while a man willing to belittle past employers will usually be found hiding behind a question mark.

Interesting workmen is vitally important, co-operation resulting. Men like to co-operate on a participating basis. Encouragement inspires suggestiveness in men and intensifies effort. Often we have thought of something and in a round-about way solicited opinion. From many suggestions we got a little better idea and gained co-operation in advancing it.

The individual and his inclinations is a remunerative study. Failure in one capacity is no absolute evidence of his worthlessness. Every good man has his element. The problem is to discover this and place him in the proper place.

Square dealing, preparedness and precision in plan and execution are essential to best results in introducing an idea. A scheme once launched will often capsize at a single break in piloting it.

Men love and trust the open plan. Improvements were

made on a car bearing boring mill to increase its output by nearly one-half, and a test made. Nothing was concealed, the regular operator being told to get out 500 bearings as quick as honest effort could accomplish it. We figured on nine hours; he did it in seven hours forty-two minutes.

All classes of men have leaders. In scheming it pays to reckon with them. We once changed our machine molding system, encountering stiff opposition from the men. We got in touch with a leader, offered him inducements to give the thing an honest trial and we would abide by the results. He accepted, and the system worked to the ultimate satisfaction of all.

In all departments waste of material and abuse of equipment demand consideration. To overcome this waste we have disciplined and fined more or less effectively. Greater than all, however, we attempt to educate workmen to a keen sense of moral obligation. To the guilty man we now present a serious analysis of his conduct and inquire what he would do if he were in authority.

Progress on work passing through different channels to completion merits attention. We find it a good plan to draw sharp lines of related responsibility and hold each man strictly accountable for conditions in his field.

Cultivating a spirit of helpfulness with other department heads is a broad idea. We invariably aim to accommodate.

Teaching men to work from motive instead of precedent develops efficiency. The automaton is the zero of accomplishment. We scheme to better things by taxing individual resources and withdrawing temporary aid.

Little meeds of praise count much. Each task faithfully performed, every added year of good service, merits recognition. To accord such spurs men to stronger effort.

In discussing plans or issuing instructions we find the plural "we," a much better pronoun than the singular and exclusive "I."

New and added equipment offers splendid opportunities. We always encourage men to study machines and equipment, discover shortcomings and suggest improvements.

Encouraging men to familiarize themselves with details of work outside their own prescribed effort, though related to it, is often beneficial. We find this admirably applicable in foundry casting inspection where familiarity with the principles of molding is a great aid to high-class inspection. Actual demonstration of a machine's reasonable capacity will often work in spurring indifferent workmen to put forth more effort. Sometimes we put a hustler on a job just to show some indifferent man what the possibilities of the job really are.

Shop order and cleanliness are important. We remember a dark corner and a bad machine where nobody worked with heart. We cleaned the place up, added new lighting facilities and repaired the machine. The dark corner and poor machine jumped above par at once.

**RUSSIAN COAL.**—Russia's production of coal during 1913 amounted to about 31,000,000 tons, and in 1914 to 28,000,000 tons. As the Polish districts, which in 1913 yielded 22 per cent. of the aggregate output, are now occupied by Germany and Austria-Hungary, Russia's production of coal for 1915 cannot be estimated at more than 20,000,000 tons.—*Engineering.*

**SAFETY OF CLOSED FEED-WATER HEATERS.**—Closed feed-water heaters become weakened from the corrosive action of feed waters, and serious injuries by scalding have resulted from the unexpected rupture of the shells. To guard against accidents, the shell of a closed heater should be frequently subjected to a test pressure not less than 50 per cent greater than the highest pressure possible for the discharge from the feed pump. Trials of the safety valve should also be made to determine its condition and the ampleness of its capacity for safely relieving excessive pressure when the feed pump is operating at its maximum.—*Power.*



# SPOKES IN THE ROUND-HOUSE WHEEL

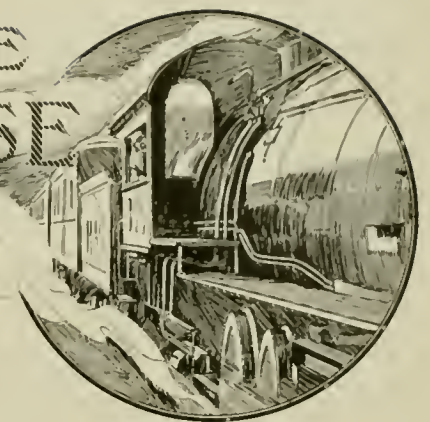

Two Articles Which Were  
Submitted in the Engine  
Terminal Competition

## HANDLING A BIG ENGINE TERMINAL

BY PAUL A. SCIENCK

There are today more enginehouses which are having difficulty in meeting the service demanded of them, due to poor facilities than to poor organization or poor management. The size and number of locomotives has increased at a greater rate than have the facilities for handling them. In many cases, a recommendation from the enginehouse foreman might bring about needed improvements. In other cases he might help himself. Possibly he has a compressor which will not maintain a working pressure and although he has asked for a new one, his men have been kept so busy trying to drill out broken bolts and bead tubes with 50 lb. air pressure, that he has not had time, or rather has not taken time, to overhaul the compressor and repair the leaky pipe lines. It may be that he has done everything in his power, but his superior officers have been too busy putting new rail on the main line to put in a new outbound track at the engine house or a new motor on the turntable.

It is deplorable to see the struggles that are made to meet the service of today with the enginehouse and terminal of 15 years ago. The ties and rails have been replaced, the locomotives have grown in size and power, the cars are bigger, the yards have grown, the freight houses have grown; in fact everything has outgrown a large percentage of the enginehouses in service today.

For efficient work, the tracks from the yard or station to the enginehouse should be so arranged that an engine which has but a short time from its arrival to leaving time does not have to spend two out of the three hours in going and coming from the station to the enginehouse. The inbound as well as the outbound tracks should pass the coal chute, and the chute should be of a capacity large enough so that coal will be always waiting for the engines instead of the engines waiting for the coal. The same may be said of the water service.

Some ashpits are so designed that it is impossible for one engine to pass another at this point and delays occur accordingly. With an ashpit so arranged that one engine can be run around those already on the pit, it is an easy matter to give a "short turn" when desired. Where there are perhaps three engines having their fires cleaned and two behind them awaiting their turn, and but one track over the ashpit, it takes time to have the fire cleaned on an engine coming in for a quick turn, and it is hard to explain to the despatcher why it has taken an hour and a half to clean the fire and turn an engine on the turntable.

Next comes the turntable, or "king pin" of the engine terminal. When the turntable stops, the entire plant stops. Is the best any too good for this important factor? In order to despatch 100 engines a day, the table must turn two hundred times in getting the engines in and out, 40 times more for other purposes such as "spotting" dead engines, putting

in wheels, etc., making 240 times in every 24 hours, or an average of once every six minutes. If an electric motor is used to drive the table, an emergency engine of some description should be mounted and ready for service at the other end. No matter what power is used, for that matter, there should be something besides pushing by hand, to fall back on when it fails.

Before going into the house, let us look at the outbound, and storage tracks. Are there several tracks or but one track by which an engine may leave? Although all of them converge into but one outbound track passing the coal chute, there should be several between this point and the turntable, where outbound engines may be lined up when they are ready for service and the room which they occupy in the house is needed for other engines, or when there are so many due to leave about the same time of day that it is impossible to handle them all over the turntable without a delay to some. A sufficient number of storage tracks to accommodate all extra engines, engines awaiting material, stored engines, extra wheels, etc., are indispensable. In many cases, the capacity of an enginehouse may be easily increased by the addition of storage tracks. There is no need of taking up valuable room in the house, with engines which are apt to lie for any length of time.

If the enginehouse is located in a climate of severe winters, it should be long enough so that the doors can be closed behind the engines in the house if effective results are expected from the workmen. No matter what the heating facilities are, no house can be kept warm if the doors are open and a cold house is an inefficient house. How can a man keep his mind on his work if he is having a struggle to keep warm?

Drop pits should be furnished which are suitable for all wheels. If tank and engine truck wheels can be renewed in an hour by using a drop pit, where it would take four hours without, not much figuring is needed to indicate the saving thus affected.

The better the power plant and machine shop, the more efficient will be the enginehouse. The old idea that any machine, boiler or compressor which has been worn out in the shop should be put up in an enginehouse instead of being scrapped, is fortunately dying out. As a rule a shop is better able to get along with a machine which is on its "last legs" than is an enginehouse. The machines may not be used steadily from morning till night, but an important train may be delayed on account of a lathe breaking down while boring a set of piston packing or a drilling machine failing while drilling a crosshead shoe.

The storeroom is a hard proposition at the best and one which requires the closest kind of co-operation between the enginehouse foreman and the storekeeper; but in far too many cases the former expects the latter to be somewhat of a mindreader in regard to material needed. If he would spend more time in going over the stock with his storekeeper and

weeding out the surpluses, the latter could order more of the essentials without fear of being reprimanded for carrying too large a stock.

The best organization is the one which can turn an engine in the shortest time without overlooking any work. A large blackboard will be of great benefit to any enginehouse in recording the progress of work. The size of the board in regard to length depends upon the number of engines handled and the items may vary to suit local conditions. A separate board for each division using the terminal will be found convenient.

A man who has had experience enough to be a foreman should know about how much work a man can do in a day or a certain time without watching him, and can put all of the work slips on certain kinds of work into a box where the workmen can get them. A box of this kind located near the black board will save many steps both for the foreman and the men.

The greater the responsibility felt by the men, the less supervision is necessary and the less the foreman will have to carry; and the more time he will have to investigate and improve the general conditions of the enginehouse. If this responsibility is not already felt, it can easily be brought about little by little until the pipe fitter will take so much pride in the condition of his pipes that he will tighten a check pipe which he sees leaking without waiting to be told, and do many other little jobs which take but little of his time when done in this way. On the other hand, were the leak unnoticed until the engineman had found it after backing out of the house, he would have to hunt up the foreman, who, in turn, would have to find the pipe fitter, stop the work which he was doing and by the time the leak was repaired, the engine would be badly delayed. Moreover, the foreman would have lost his time and his temper, and the pipe fitter would be disconcerted for an hour. The same can be said of the work of the air brake inspector, the cab man, and, in fact, all work which is specialized and looked after by one man or gang of men.

Some difficulty may be found in locating the inspector, or whoever is wanted, without considerable hunting. This is overcome by the flag system, under which each specialist carries a flag or lantern of distinctive color and when he goes to work on an engine, places it on the pilot. This system is used on several roads with good results.

One of the hardest problems is keeping the house clean and the space between the pits clear of obstructions. If the floor is once cleaned up and each individual given to understand that they must pick up all tools, scrap, and material of all kinds when they complete a job, the floor can be kept clean.

With proper facilities and organization, the efficiency of an enginehouse should increase with the size of the house up to the limit of the turntable, for the larger the terminal, the greater is the opportunity for installing systematic and efficient organization, where someone is responsible for every move and each part of the locomotive, from the time of arrival until it leaves on its outbound trip. Any hitch in the work while the locomotive is at the terminal, or the failure of any part while it is on the road, can then be easily traced to the individual responsible.

### SOME NOTES ON ENGINE TERMINALS

BY GEORGE TWIST

Locomotive Foreman, Canadian Pacific, Fort William, Ont.

In considering the management of an engine terminal we must commence with the general foreman. He should be intelligent, courteous, farseeing and above all, ambitious and enthusiastic. Without ambition and enthusiasm he cannot be successful as undoubtedly he will be subject at times to criticism which would knock the spirit out of a man without these qualities. He must gather around him a staff of fore-

men, any one of whom would be able and willing to handle the station successfully in his absence. His staff should be so organized that every man's work, no matter how seemingly unimportant, may be checked up and the responsibility placed for failure.

Shop tracks should be so laid out that the possibility of a tie-up through accident will be reduced to a minimum. Crossovers should be suitably placed to enable an engine to be taken out of a line of power when required for quick turn around or to go into the shop. It frequently happens that engines are required for special service, or for work that men are waiting to perform and it necessitates a lot of unnecessary switching to get an engine into the shop at such times. Shop trackage laid out with convenient crossovers will avoid such extra work and consequent delays.

Suitable lockers should be provided in a clean room to permit of the men keeping their clothes clean and comfortable. In too many roundhouses there are used open steel-work lockers through which the steam, water, and smoke can pass and come in contact with the clothing. All shops should be kept clean and comfortable in order to obtain the best results from the workmen.

Hostlers should be assigned to special work where the output of terminal is sufficient. For instance, the work of turning in should be handled by a different hostler or hostlers from that of turning out. Hostlers taking charge of engines on arrival should inspect the firebox and see that the leaks are promptly reported. Many cases have occurred where the responsibility for damaged boilers due to low water has not been properly placed because of not inspecting engines on arrival.

When taking coal care should be taken not to overload tender, and the coal should be trimmed so as to avoid waste through allowing it to fall on the right of way. When an engine is standing over the ashpit, the air pump should be shut off in order to avoid the possibility of dust being drawn into the pump and causing unnecessary wear. In knocking out and cleaning fires, water should be used freely in the ashpan and pit to keep down the dust. The blower should not be used too strongly when cleaning or knocking out fires as this is frequently the cause of tubes and staybolts leaking. In moving engines around shop tracks, care should be taken to see that all switches, derails, etc., are set correctly, and engines should not be moved too fast. Considerable delay might occur through carelessness or negligence in this. If engines are pooled, all tools, etc., should be taken off by a man assigned to this work and put away in the place provided for this purpose. Hostlers should see that no tools or equipment are left unprotected.

When an engine arrives in the shop, no time should be lost by the different foremen in getting their men to work in order that no unnecessary delay will occur in getting power back into service. The men assigned to the work should be chosen only because of their qualifications. Roundhouse work is often looked upon as rough and not very particular. This is a wrong viewpoint; every job should be done properly. If at any time due to lack of time or of material a thoroughly perfect job cannot be made the foreman should decide what means to adopt. No workman should be allowed to put up a makeshift job on his own responsibility as this tends to encourage and cultivate the habit of letting work go improperly done. Foremen should be kept informed of the special or heavy work required, and a bulletin board marked up for the information of hostlers and others, so that engines may be placed in a part of the shop set aside for special work.

Every man should be instructed in his special duties and should be disciplined for neglect. Care should be taken by boilerwashers to avoid scale and grit being allowed to get into the machinery, and good canvas coverings should be provided. Foremen should check up the work being done

and men who are not giving value for the money they are getting should be cautioned and assisted to improve; if after a reasonable time they do not show improvement, they should be replaced. Boiler foremen should go into fireboxes on every possible occasion and check up the tube cleaners, as this is a job which is frequently improperly done, men often cleaning the tubes only a short way in. Boilermakers and tubers should be taught the proper use of the heading tool as it has been found that the improper use of this tool is accountable for much trouble from tube leakage. Tools should be abundant and kept in good order.

A close check should be kept on work reports, and jobs which are booked to be done and O. K.'d by mechanics, and are later reported again should be examined personally by the shop foreman, in order that steps can be taken to prevent engine failures which frequently occur through work being improperly done. It often happens that an engine comes in trip after trip requiring new piston rod packing. Investigation will probably reveal the fact that the crosshead is very slack in the guides, the piston too small for the cylinder or that the rod is bent or scored. Each time work is improperly done means loss of time and money. When an engine is O. K.'d and is ordered out on the road care should be taken to see that the crew is around in time and that nothing is allowed to prevent its leaving in ample time, fully prepared in every way to make a successful trip. Regarding terminal delay and engine failures, if every man understands his duties and performs them properly, and foremen and engine despatchers insist on engines being O. K. before supplying them, the delays will be few. There are engine failures that are sometimes unavoidable, but experience has shown conclusively that a large majority are man failures and could be avoided. Pick out the proper men to inspect and repair the power, lay down instructions and see they are lived up to, take no unnecessary chances, and the engine failures will be reduced to a great extent. In conclusion, just a word about organization. No foreman has his shop properly organized unless it is possible for any man to be away from his duties and still have his work go along smoothly. This applies particularly to the foreman himself. The most perfect organization is the one which allows the foreman to be the least missed of any man.

### CLEAN LIGHTING FIXTURES

There is nothing on a railroad that depreciates so rapidly as does the efficiency of the lighting system. The rapid collection of dust and smoke on the lighting fixtures causes the illumination to be reduced to about 50 per cent. of its initial value in some locations within a week, and in the average station or shop it would reduce to about 50 per cent. efficiency in one month.

The saving effected by systematically cleaning reflectors and lamp bulbs will more than pay for the small extra expense involved. The following example will serve to emphasize this point. Take a railroad which operates 5,000 150-watt lamps and assume that these lamps burn eight hours out of every 24 and that the cost for current is two cents per kw. hour. The total cost of current per year then will be \$37,560. It has been shown in numerous tests that a collection of dust and soot on reflectors and lamp bulbs will reduce the illumination by 50 per cent. This means that if the 5,000 reflectors and bulbs above mentioned are not cleaned half of the light from these lamps will be absorbed and wasted, causing a direct loss of \$18,780 per year, while on the other hand this amount will be saved if the reflectors and bulbs are systematically and regularly cleaned. The cost of cleaning will not amount to more than three cents a fixture a month or a total of \$1,800 a year, which is only 9.6 per cent. of the saving. In other words 1,040 per cent. will be earned by the investment.

In addition to the saving in energy thus effected will be the saving in workmen's time which would be lost due to inadequate illumination if the reflectors and bulbs are not cleaned. Ordinarily the expenditure for lighting is about 1/2 of 1 per cent. of the wages of the workmen employed, while to properly maintain that lighting system costs only about 1/30 of 1 per cent. of the wages.—*Railway Electrical Engineer.*

### FORGE SHOP PRACTICE

BY V. T. KROPIDLOWSKI

There is often considerable choice of method in forging, and the skillful workman selects that method of procedure which will produce the results with the least amount of manual labor. The practices in blacksmith shop work herein illustrated were described to the writer by an expert in smith shop work. Fig. 1 shows the method of forging a cage for a spherical valve of a deep well pump. First, hammer out a round disc to the required thickness and diameter,

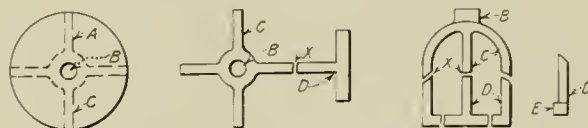

Fig. 1—Forged Cage for Spherical Pump Valve

leaving a boss B, into which is to be screwed the pump rod; then cut out the solid segments A, leaving the portions shown in dotted lines. The segments cut out make four tee-shaped pieces D, of the required dimensions, the Tee being thicker than the "stem," so that thread can be cut when the cage is finished on the inside, E, for a brass seat to be screwed

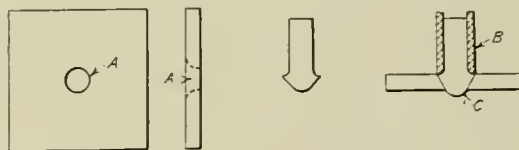

Fig. 2—Forging an Expansion Plate with a Gudgeon

in. Having made the Tees, they must be welded to the other piece at X. The whole is then shaped over a mandrel. The bronze cages usually break in a short time, due to crystallizing of the metal, but wrought iron cages made 13 years ago are still in service.

Fig. 2 illustrates the forging of an expansion plate with a gudgeon. Cut off a square piece from a flat bar, punch a

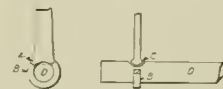

Fig. 3—Welding on a Tumbling Shaft Arm

hole A and scarf it as shown. Cut off a piece from a round bar and upset it at one end as shown. Set the upset end in the hole A and use a tool B in making the weld. Strike a few blows on C and the expansion plate is made.

In welding an arm at right angles to a round bar in making a tumbling shaft, Fig. 3, take a piece of 1-in. square iron, B, and weld it around the round bar D. Hammer out the arm and upset it to form the required end; fuller out the round bar as shown at C, and set the arm in the fullered place in the bar D. Strike with a hammer on the fillets of the arm and also on the ring B, to weld it to the arm at A.

Fig. 4 shows the forging of rod straps. Hammer out a

bar of rectangular section to the required width and the thickness wanted at the end of the rod; or if the boss to form the grease cup needs to be thicker than the end, make it of that thickness, fuller it out as shown and draw down

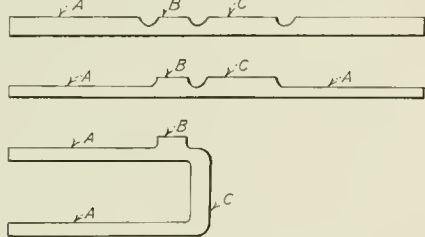

Fig. 4—Forging Rod Straps

the ends *A*, leaving *B* and *C* the same thickness. Bend it to shape as shown.

Fig. 5 illustrates a method of forging valve yokes. There are several ways of making a valve yoke, some probably

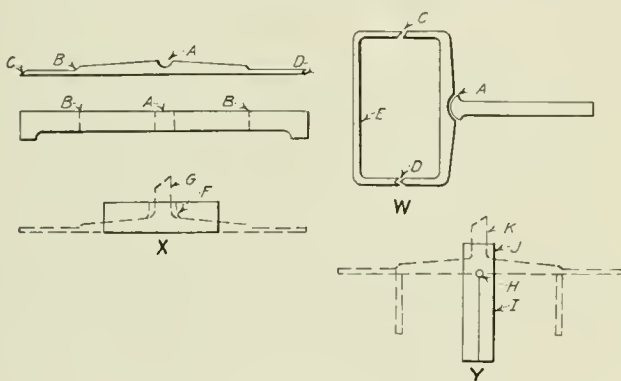

Fig. 5—Forging Valve Yokes

quicker than this, but they do not result in as good and durable yokes. One method is shown in *X*. Take a piece as shown by the full lines and hammer it out to the dotted line shape, leaving a boss which is then hammered to the

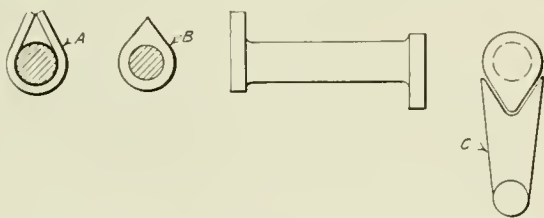

Fig. 6—Making a Rocker Arm

shape *C*, when the stem can be welded to the scarf. This method has the objection of the stub *G* being cross-grained, and invariably it will break. Another quick method, which usually is the most common practice, is shown in *Y*. Take a piece as shown by the solid lines, punch a hole *H* and

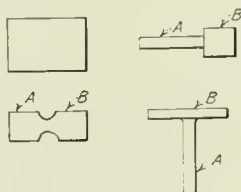

Fig. 7—Forging a Link Saddle

split the piece along the line *I*; spread it and hammer it out and bend as shown by the dotted lines; then draw out the boss *J* to the shape *K* and weld the valve stem to the scarf. This has the same objection as the first one, the metal being

cross-grained. The best method to obtain a strong job is as follows: Hammer out a shape as in *W*, and fuller out at *A*. Hammer out another piece *E* and weld to the front piece (after both are bent) at *C* and *D*; either a scarf can be used, as at *C*, or the method shown at *D*, the latter being recommended. Now hammer out a round bar, upset it, and weld it into the fullered space, as at *A*.

Fig. 6 shows the making of rocker arms. Take a piece *A* of square section and the required dimensions and weld it around a round bar at the end; repeat at the other end as shown. Now hammer out two arms *C*, the required size and shape, U them in and weld to the ends as shown.

Fig. 7 illustrates the forging of a link saddle. Take a rectangular piece like that shown, of the required dimension. Fuller it out on both flat sides, then draw out the end *A* round. Flatten out the end *B* to the required dimensions.

## PISTON VALVE PACKING RINGS

BY JOHN V. LeCOMPTE

The piston valve is much better than the slide valve for locomotives; it is more equally balanced and has low cost of upkeep. The built-up type piston valve, composed of one spool, two bull rings, four packing rings and two follower heads, which clamp the valve rigidly in position and form walls for the two end rings, gives the greatest satisfaction. To obtain the best results from this valve the bull rings should have a limit of wear not to exceed 3-16 in., so as to provide a bearing surface of the packing ring on the bull ring great enough to hold the ring in its proper position. The same is true of the follower heads. The end play of the packing ring should not exceed the thickness of a piece of paper, and should be just enough to permit the packing ring to work freely.

The wearing surfaces of a valve should be made of the best material possible to insure long life to the valve, a good mileage and low cost of repairs. This is especially true of the packing rings. The rings should not only be made of a good quality of iron, but they should be carefully turned and applied to the piston valve chamber in order that they will satisfactorily do the work required of them. The rings should be turned on a machine having two heads, both heads being used at once. They should be turned 1/8 in. larger than the bore of the valve chamber bushings, and, after they have been properly cut, they should be clamped snugly together on the face of a lathe or any other machine suitable for this purpose, and turned to the exact diameter of the bushings, and also at the break in the rings. After the rings have been made they should be handled with care, as careless handling in assembling, or applying them to the valve chamber, has often destroyed the efficient work done in their manufacture.

The valve chamber bushing should be maintained round and should be bored if it is 1-16 in. or more out of round. The cylinder casting itself should be properly bored, for otherwise new bushings, that are accurately bored, will be distorted when forced into the cylinder casting, which will necessitate reboring the bushings after they have been applied. If the rings are properly made and properly applied to perfectly round bushings, the oil consumption will be reduced, better mileage will be obtained, and there will be a reduction in repair costs.

PLACING U-BENDS IN PIPE LINES.—The bend should be in the same plane as the pipe; that is, it should be so placed that the ends will be forced nearer together or drawn apart by the action of expansion or contraction of the line whose variation in length it is intended to compensate by the flexibility of the bend.—Power.



# WHAT THE BOYS THINK OF APPRENTICESHIP

## Half-a-Dozen Letters From Live Apprentices With Suggestions as to Improved Practices

The two prize articles in the recent apprentice competition, together with three other letters, were published in our April issue, page 197. The following letters were received in this same competition:

### AN APPRENTICE SCHOOL IS NECESSARY

BY WILLIAM HEISE

Machinist Apprentice, Erie Railroad, Jersey City, N. J.

I don't think anything quite equals a well-equipped, well-regulated apprentice school, with a capable, intelligent instructor, for aiding the apprentice. Those boys who already have a good knowledge of mathematics and drawing can go ahead with other more advanced studies. A little theory in the school room will aid them considerably in their shop practice.

A machinist apprentice should learn all about the various machines he is taught to operate. When he is working on locomotives the same thing should apply. The instructor would do well to give the boys lectures from time to time on lubricators, pumps, injectors, superheaters and the like. A few models for valve setting and shoe and wedge setting would not be amiss in the school room. Charts could also be hung around the school room walls with such important data as the various cutting speeds and feeds, and the proper way to grind cutting tools and drills. In fact, anything at all important pertaining to the machinist trade should be brought to the attention of the apprentice.

The boilermaker apprentices also have much to learn regarding their trade, which can only be taught in the school room. It is well enough to know how to do a certain thing, but it is also important to know why it should be done in that particular way. The boilermaker's apprentice should learn where to apply single or double rows of rivets, and the strains which rivets and staybolts must withstand. There is just as large a field of study for the young boilermaker as there is for the machinist.

The blacksmith apprentice has a somewhat different and more difficult proposition to deal with. There are, of course, many books written on the heat treatment of steel, forging, tempering, etc.

I think that it is up to all machine and repair shops of any considerable size to establish an apprentice school, if they have not already done so.

### DON'T SCOLD

BY ARTHUR J. MERRIMAN

Boilermaker Apprentice, Atchison, Topeka & Santa Fe, Richmond, California

During my career as an apprentice I have found that the more a foreman encourages an apprentice the more willing he is to work and strive harder to succeed. One word of encouragement is worth more than all the scolding. Some foremen, of course I am not saying all, are in the habit of getting very angry when an apprentice makes a mistake. He is bound to make mistakes; if he did not, he would not be an apprentice.

After an apprentice finishes his course he does not want to get it into his head that he is through with his schooling. He is just beginning, and it is going to take a great deal of study on the outside to make of himself a capable and efficient mechanic.

I do not know if all railroads have established apprentice schools, but if other roads are working under the same system

as the Santa Fe I cannot see how to make the apprentice course of greater practical value.

In the shops where I am working I have noticed a great deal of improvement in the last four years. The work is done now with more science and a great deal quicker. This road makes a practice of promoting its own men to fill vacancies as they occur, which I think is very good.

### TEAMWORK BETWEEN SCHOOL AND SHOP

BY WILLIAM L. LENTZ

Machinist Apprentice, New York Central, Avis, Pa.

The apprentice school not only educates us for better and higher positions at the expiration of our apprenticeship, but makes it possible to attain more than a common school education. Then, too, the elements of that which inspire and make it possible for an apprentice to develop in knowledge may be found in the methods employed and advantages which these schools afford. This is not only true in regard to the four hours each week in the school room, but also of the confidence and tests of proficiency by the management during the regular working hours. The privilege of putting to a test the question or questions that arise, and which cannot be thoroughly solved in the school room, appeals greatly to the average apprentice. Furthermore, I am strongly impressed with the trust bestowed by the officers permitting us to perform special duty whenever it is necessary.

A greater interest would be taken in each apprentice school if a reward were given for the amount of work accomplished. Such a reward may be effected by awarding a bonus for all sheets of home or classroom problems, or other courses over the number required of each apprentice every month. This bonus may be any one of a number of articles, one of which may be a portion of a series of books similar to the Mechanic's Hand Book.

During the past two years of my apprenticeship I have visited three different railway shops in which apprentice schools were established, and have found the greatest mistake to be that the average class instructor does not know the situation among foremen, mechanics and apprentices. While the latter are being taught up-to-date methods of doing work by the class instructor, their superiors throughout the shop are teaching them methods many years behind the times. This has a tendency to keep both the school and shop efficiency down.

Many of the shop instructors become discouraged when instructing a boy who may be deficient in understanding. To overcome such a condition he should overlook these shortcomings and assist him in every possible way, instead of neglecting him entirely. Negligence and partiality on the part of instructors make all these deficiencies possible, and may create in the mind of the apprentice boy the impression, "I am not getting a show."

### THE RIGHT AGE TO START IS 18

BY NIELSEN POLLARD

Fourth Year Apprentice, Atchison, Topeka & Santa Fe, Albuquerque, New Mex.

The greatest factor in producing expert workmen from the average apprentice is the instructor, and by instructor I mean anyone who may have occasion to show an apprentice anything pertaining to his trade. Thus the need of having a good, clean and competent working force in clean and sanitary surroundings may be seen. These are first requirements

without which it is useless to try to produce expert mechanics. Also to produce efficient workmen the shop itself must be efficient with good, up-to-date machinery.

The instructor must be a man that apprentices can respect. If he is interested in their sports and can join in with them he can gain their confidence much more quickly. It is also a great advantage for an instructor to have served his time as an apprentice, for in no other way can he understand the apprentice's private opinion of his job.

The apprentice believes he is there to learn his trade, not to see how many pieces of work he can turn out in a day. This is why I do not believe in a bonus system for apprentices. One must first learn thoroughly to do a job correctly before he can speed up, and when he has learned to do a job correctly it is time to go to something else. At any rate, bonus will have very little effect on an apprentice who is interested in his work. A good apprentice will not slight any thing for bonus, and he will not be capable of turning out good work any faster than he is.

And last, but not by any means the least, and perhaps from the employer's standpoint it is the first, is the selection of the apprentice. I believe that the older the apprentice is when he starts the better he will be when he graduates. If he is 18 years old he will have outgrown his boyish tendencies toward having a good time during working hours and will settle down to a good, steady pace. Also if he is 18 he will have had time to go to high school, and the more general education a boy has the better it will be for all concerned. Also an apprentice of 18 will practically have attained his growth physically, and a good strong body certainly helps; at least it does in locomotive shops. I have seen apprentices with no great intelligence forge far ahead of the others simply on account of being strong and husky.

### THE NEW APPRENTICESHIP

BY WM. JOHNSTON

Fifth Year Locomotive Apprentice, Canadian Pacific, Montreal, Canada

Hand in hand with the rapid increase in train tonnage, larger locomotives, heavier cars and extensive shops has risen the demand for more efficient mechanics to cope with the maintenance and operating conditions of the railroads of today. To this end the old apprenticeship system has had to give way to better.

The old system of rough and tumble, get through anyhow, of favoritism and its attendant discontent and discouragement to the less favored apprentices, has passed, and in its place has come a golden opportunity to the young mechanic, where systematized instruction in the modern theory and practice of the trades is given by expert instructors. Under the new system merit, grit and intelligence are the only factors that count; each apprentice has an equal chance to make good; his work is carefully inspected and criticized, advice being given towards improvement.

In conjunction with the practical shop work is the school work, the apprentices being paid the regular rates while in school, a thing unheard of a few years ago. Scholarships are offered annually, enabling the brightest apprentices to continue their studies into their future life's work, and many of the modern roads maintain a university scholarship for those of their apprentices who qualify, thus enabling an earnest, ambitious young apprentice to start right at the foot of the ladder and to climb right through to the uppermost rung of the profession by simply applying himself and grasping each opportunity offered by his apprentice course.

The social side of apprentice life has also expanded. Many lines now encourage and organize baseball, amateur athletic and debating clubs and inter-shop teams, and matches are regularly played, lending an altogether different aspect to the former humdrum existence of the apprentices.

More attention might be paid to attracting the young men

graduating from the high schools, who at present largely drift into poorly paid office work, through ignorance of the splendid opportunities offered by the leading railroad apprentice courses and the great and ever increasing field of engineering with its persistent demand for highly skilled, intelligent mechanics and engineers. It is not enough that a young man be started on such an apprentice course and left to strive along, but rather efforts must be made by the departments to keep up his enthusiasm in the work during those four or five long apprenticeship years, by keeping a definite goal or objective vividly in his view.

A new day has dawned in apprenticeship methods, the day of the self-confident, ambitious and efficient apprentice who can use his head as well as his hands, with the result that a better and closer feeling of loyalty is steadily growing up between the graduating apprentice and his railroad alma mater. But the full benefit will not be obtained from the courses until the apprentices have been educated to grasp the present opportunities and facilities to the limit.

### FOUR SUGGESTIONS

BY CARL J. PRYOR

Apprentice, Atchison, Topeka & Santa Fe, Clovis, New Mexico

Without any doubt, the most inspiring and helpful feature of the modern railway mechanical apprenticeship course is the arrangement whereby the training in the shop is supplemented by a study in the school room of mathematics, elementary mechanics, railway shop practice and drafting. No longer is the road to advancement to positions which require a technical education closed to the young man who did not have the opportunity to finish his education before beginning to serve his apprenticeship. The modern apprentice school gives such a young man an opportunity to acquire the first steps in a technical education. It trains him to study and gets him in the habit of studying, so that a boy who is ambitious and anxious to learn has a fair education at the end of four years and the ability to pursue any line of technical study he may desire.

The shop instructor instructs the boy at each new step, sees that he gets a chance to learn all the classes of work in the shop, that he is given fair treatment by all, and that the apprentice behaves himself, both while in the shop and off duty.

Following are a few practices which, in the writer's opinion, could be altered and be of practical benefit to the railroad:

(1) The greatest aid would be actually to convince all the officers, from the highest to the lowest, that the only way to insure a supply of intelligent, competent and loyal workmen to meet future requirements is to educate and train them in the present.

(2) There is too great a tendency to entirely excuse the apprentice for all his mistakes in judgment and work. There are foremen who are afraid honestly to criticize an apprentice, unless the case is serious, for fear they will be misunderstood by the higher officers and be considered as too hard on the boys. An apprentice who is not taught responsibility will become a mechanic that cannot always be relied upon.

(3) The length of the apprenticeship should be made variable, with perhaps a fixed minimum, or the scope of the work the apprentice is to learn should be made variable. With the present system the idea seems to be to hold each boy on each class of work about the same length of time regardless of his ability. This plan must work to the detriment either of the bright, hard-working, quick-learning boy, or the slower, less gifted one.

(4) Make the shop instructor, not the foreman, absolutely responsible for the work done by the apprentices. This causes the instructor to break in the apprentices in such a way that they will not slow down the work and thus does away with the average foreman's main objection to the apprentice.

## A DOUBLE THERMIT WELD

BY ROBERT W. MILLER

Foreman Blacksmith, Cincinnati, Hamilton & Dayton, Cincinnati, Ohio

Recently we received two locomotives at the Ivorydale shops of the Cincinnati, Hamilton & Dayton, each of which had two broken frame rails, the breaks being located one above the other in the top and bottom rails of the main frame just in front of the forward pedestal jaw. As no other repairs were required on the engines and they were needed in service the possibility of Thermit welding both breaks at one time suggested itself as a means of reducing the time that they would be held in the shop. As there would be difficulty in securing the right amount of expansion on the second weld if the job were completed in two welds, which would not be

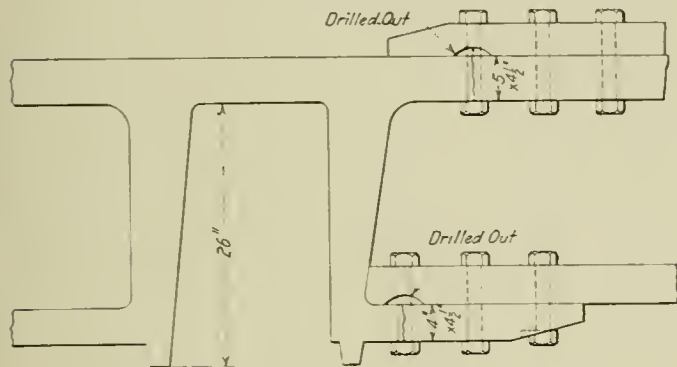

Location of the Fractures in the Main Frame Rails

experienced were both fractures to be welded at the same time, it was decided to use one crucible and make both welds in the same mold. For this work but one pair of wheels was dropped and the crosshead was disconnected but not removed, the guides being left in position.

The fractures were first drilled out to a width of one inch and the metal of the front rails also removed, as shown in the sketch of the frame, to allow a free flow of the welding metal and to assist in reinforcing the main frame at the welds. A

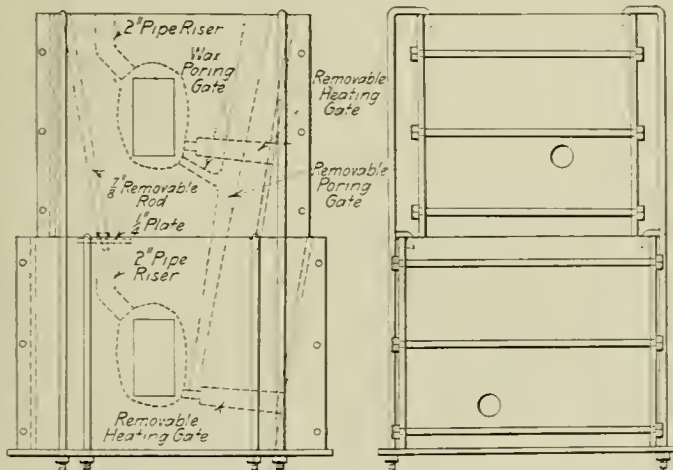

Arrangement of the Mold for Double Thermit Weld

bar of iron 2 in. by 4 in. in section was placed across the engine against the back cylinder heads and the pedestal binder put in place. By means of a jack, placed between the front end of the binder and the bar, an equal expansion of 3/16 in. was secured on both rails. A box was then built up around the bottom rail, just as it would have been if but the one weld were to have been made. The wood pouring gate, however, was long enough to extend up to a point above the riser on the top weld. With the wax mold in place about the lower

fracture this box was filled and tamped with the usual mixture of one part fire clay and two parts sand, the top of the riser being covered with a 1/4-in. plate, through the center of which a hole was drilled. This was closed by a 7/8-in. rod, the end of which was reduced in diameter to fit the hole in the plate. The top box was made 2 in. smaller all around than the lower box, the two being held together with the tie rods, as shown. A wax connection was made from the main pouring gate to the top mold and the upper box was filled and tamped in the usual manner, the vent in the plate over the lower riser being closed with the 7/8-in. rod. The risers in each case were formed of 2-in. pipe.

With the mold complete the frames were preheated with two torches, one being used in each of the heating gates. The 7/8-in. rod was removed to facilitate the proper heating of the lower frame rail and to vent the lower mold while pouring. The success of this arrangement is attested by the fact that the lower rail reached the desired temperature first.

The welds required 175 lb. of Thermit mixture and were both successful, the engine being held out of service but little longer than what would have been required for one weld.

## THE MAINTENANCE OF THE LOCOMOTIVE BOILER

BY A. R. HODGES

General Foreman Boilermaker, St. Louis & San Francisco; Memphis, Tenn.

Before an engine is placed in service after being turned out of the back shop, the roundhouse inspectors should give it a thorough examination. The front end appliances, ash pans and grates, fire box and tubes should receive special attention. Of course this has already been done by the back shop inspectors, but the roundhouse inspector should check up all the work performed in the back shop from the maintenance point of view. For it is the roundhouse force which from now on will have to do with the upkeep of the boiler, and upon whom will rest the responsibility for properly maintaining the locomotive in serviceable condition. No mechanical man engaged in construction and repair work in the back shop can hope to make the success he should, except that he keep himself in touch with the roundhouse conditions and the performance of the locomotive while in service.

An essential element in the proper maintenance of the locomotive boiler, is to maintain an even temperature as near as possible at all times. It is detrimental to the upkeep of the locomotive boiler to open the fire door when it is permitted to "pop," as this reduces the temperature of the fire box and contraction sets in. This is liable to result in leaky tubes. For the same reason an engine should not be permitted to drift without keeping a white fire in the fire box while doing so. An injector should not be in operation when the engine is popping unless there is a hot fire in the fire box at the same time. Enginemen should endeavor to leave their engines at the cinder pit with a full boiler of water and a good fire in order that the hostlers will not be compelled to fill the boiler just previous to blowing off the steam. The water should never be raised after the fire has been dumped and the engine is placed in the roundhouse. All these precautions should be exercised to avoid abrupt changes in temperature, which are the cause of more leaky tubes than almost any other factor. Moreover, any condition necessitating frequent working of the tubes in the roundhouse, greatly reduces their life and leads to an early shopping of the engine.

The prevention of engine failures due to leaky tubes does not rest entirely with the roundhouse boilermakers, regardless of the fact that they are compelled to assume the responsibility. A proper appreciation of the effects of the inequalities of temperature in the locomotive boiler on the part of enginemen and hostlers would bring about considerable improvement.

In working over leaky tubes in the roundhouse, too often

not enough time is taken to perform the work properly. The "hot man" is urged to get the engine ready as soon as possible. Accordingly, therefore, he enters the box with his hammer and beading tool, and hurriedly and in a superficial manner works the leaky tubes. In some instances where it is difficult to hold the beading tool and hit it with his hammer he discards the tool altogether and simply uses the peen of his hammer. No doubt he stops the leaks and the engine leaves the terminal with the boiler apparently in good condition. But the moment the engine begins to work hard, or the temperature is suddenly reduced the flues will begin to leak again, and long before the terminal is reached it may be necessary to reduce the tonnage, or a complete failure may result. If investigation is made to locate the responsibility, the roundhouse boilermaker will try to justify himself by truthfully saying: "She was dry when she left the roundhouse."

Tubes should never be beaded to make them tight. Beading should be resorted to only occasionally and then for the sole purpose of laying the bead back to the sheet where it belongs. Excessive beading flattens the bead, cuts up and destroys the sheet and reduces the tube in thickness until the bead falls off and the tube loses its holding force in the sheet. Because of the improper use of the beading tool three or four different standard sizes are furnished. Size No. 1 is used in the first setting of the tubes in the back shop. The "hot work" man is furnished with a No. 2 beading tool, which is a little larger than a No. 1. As the flues are rebeaded again and again, the beads flatten out until finally a No. 3 or 4 tool is required.

If the boiler repairs have been properly made when an engine comes from the back shop, the tubes will have been swaged to a size requiring two or three good blows with a backing hammer to drive them through the holes in the back flue sheet, leaving 3/16 in. of the ends projecting beyond the sheet to form the beads. This is sufficient to fill a No. 2 beading tool, which is the most generally accepted standard. The No. 1 tool is sometimes used in applying new tubes because it requires but a scant 3/16 in. of material to properly fill it and allows a greater range of tools to take care of the flattening of the bead while the engine is in service. However, the No. 2 bead is more substantial in every respect and should be used at the outset. It should be maintained by refraining from continuous use of the beading tool as a means of caulking leaky tubes and other sizes of tools should be unnecessary.

Rollers are but little better than beading tools in the working of leaky tubes, as they expand the tube only on the fire

side of the sheet. Their repeated application also rapidly reduces the thickness of the tubes and thus shortening their life, increases the diameter of the tube holes, cracks the bridges and buckles the sheet. Although the complete prohibition of their use in the roundhouse is often recommended, I believe they may be used with good results if proper care is exercised in determining when to use them. Their complete elimination from the roundhouse and their continuous use in reworking tubes are extremes neither of which are desirable.

In setting tubes with a prosser expander the writer believes that the type B tool should be used. The shoulder on a type A expander is rather sharp, and has a tendency to shear the tube on the inner edge of the hole, while the type C does not have sufficient shoulder to form a substantial joint. The type A tool should be used not only in the application of the tubes but in their maintenance for the same reasons that a No. 2 beading tool should be used both in application and maintenance work. In applying the tubes, after they have been prossered they should be given a light rolling. In maintenance, however, the rollers should be used only occasionally. Their application after each prossering is neither necessary nor desirable to secure the best tube service.

There are many differences of opinion as to the best type of copper ferrule. Many boilermakers believe it should be heavy while others believe it should be light, and the same statement applies to its length. In some instances the best type will be determined by water conditions. The writer has obtained successful results from all types and believes that the selection depends largely on local conditions.

The proper handling of the locomotive when washing out the boiler is another important factor in the maintenance of the boiler. Where improved hot water washing and filling systems are installed, this presents no difficulty, but where hot water is not available considerable care must be exercised to avoid too rapid reduction in the temperature of the sheets. The foreman boilermaker should have entire supervision of all boiler washers and their work.

### PORTABLE TIRE HEATER

BY E. A. MURRAY

Master Mechanic, Chesapeake & Ohio, Clifton Forge, Va.

The tire heater illustrated differs from the ordinary tire heater employed in railway shops, in that it is arranged so that two burners can be used at once, so that its capacity is increased 50 per cent. We have found that kerosene is best suited for use in this machine. As seen on the drawing, it

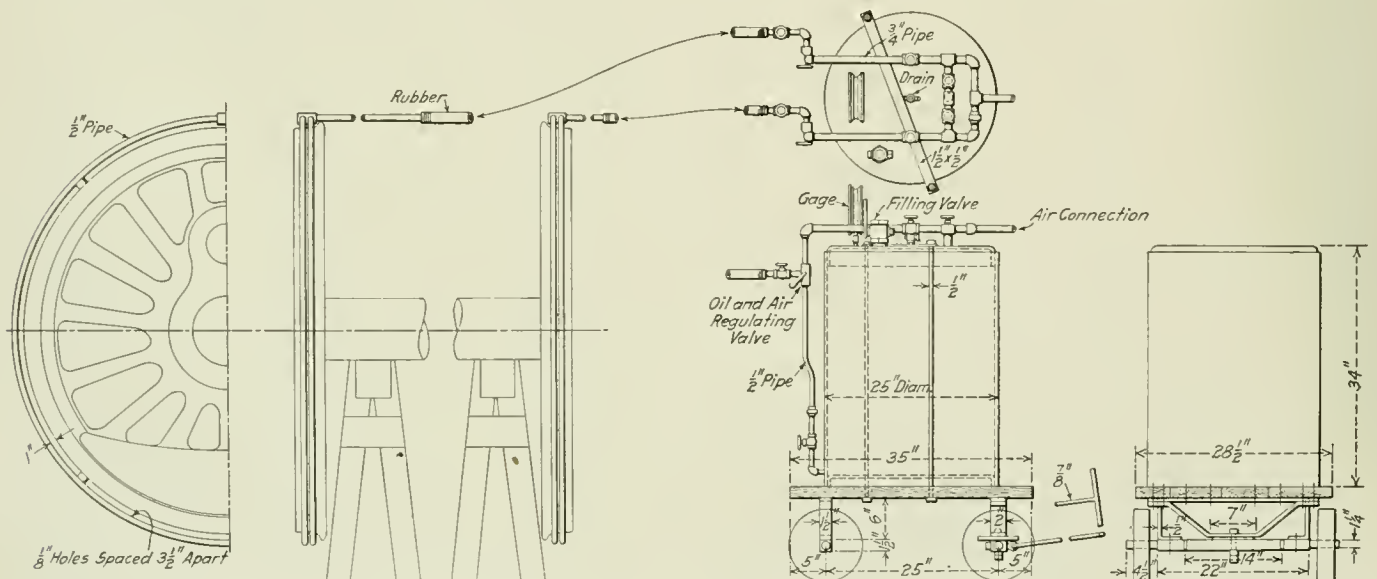

Double Ring Tire Heating Apparatus In Use at the Clifton Forge Shops of the Chesapeake & Ohio

consists of a tank 25 in. by 28½ in. mounted on a four-wheel truck, and the necessary pipe connections. The oil and air regulating valves are at the side of the tank, and the ¼ in. pipes leading from them are connected to the ½ in. heater pipes by flexible connections.

### WASTE STORAGE CAN

BY C. W. SCHANE

The sketch shows a type of waste storage can for clean and soiled waste that is discarded, but can be of further use about shops for building fires or cleaning dirty machine parts. This receptacle is fireproof, and is so constructed that it cannot be left open. It is intended for use in engine

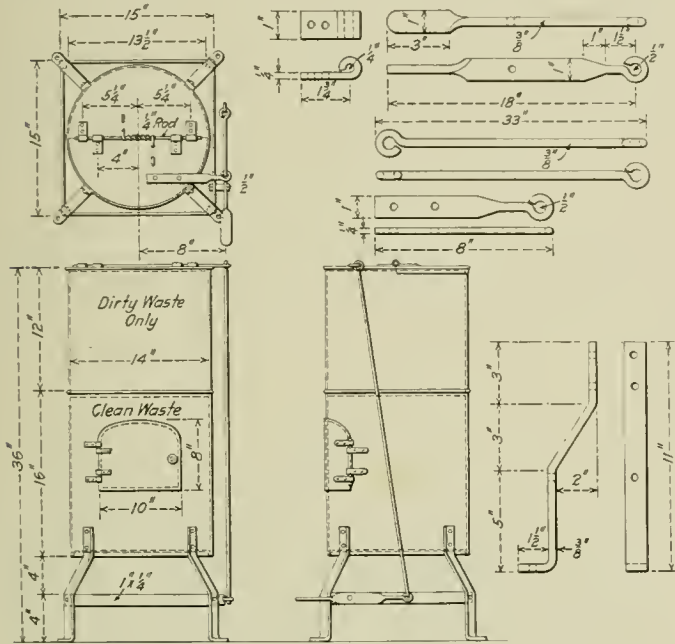

Storage Can for Waste

rooms, paint shops, etc., and will prove valuable wherever gasoline is used. It is opened by a series of levers and rods by foot power. It can be built of scrap material such as locomotive jackets or old car roofing.

### WHAT CAN BE DONE FOR THE APPRENTICE?

BY JOHN C. MURDOCK  
Boston and Albany, Allston, Mass.

Patience is a great virtue for those who have to do with the training of the ordinary boy. According to the teaching of economics, the subject must be fit, or else the time used is wasted. Let the proper subject come under a poor system of training and education, and an improper subject under a good system of training and education, and I think the one under the good system will surpass the better adapted boy under less favorable conditions.

The greatest drawback to the apprentice, as a rule, is the tendency of having output as the main effort in most American shops. Eagerness to have this output as high as possible tends to keep men on one job all the time, and the apprentice, being one of the men, becomes in many cases a specialist, not a general mechanic.

Any man having experience as a tutor will admit that the more interest he takes in teaching, the more interest the scholar takes in being taught.

\*Entered in the competition on "How Can I Help the Apprentice?" which closed September 1, 1915.

An apprentice should be taught the importance of technical knowledge from the moment he starts to learn a trade. This sharpens his mind and makes him think, and also has the effect of increasing his confidence when he finds that the theories for many things are so simple. Many mechanical blunders are made and carried through to a finish from lack of theoretical knowledge.

A suggestion to make in behalf of the apprentice would be to have a sum of money awarded as a prize for the highest percentage received. Also special training should be given students free of charge with opportunity to have time allowed for it when they show exceptional ability. This would be an incentive to strive toward higher positions.

The responsibility for the kind of mechanic turned out should rest upon the man in charge, in the same manner as he takes the responsibility for the machine output. Both are manufactured from raw material. If he is responsible for one, why not the other? Therefore, he should move the apprentice about to develop him and not place too much stress on material output.

### HOSE STRIPPING MACHINE

BY R. E. BROWN  
Machine Shop Foreman, Atlantic Coast Line, Waycross, Ga.

In order to reduce the cost of stripping and remounting air brake and signal hose, a stripping machine has been developed at this point from which excellent results have been obtained. The machine is very simple, both in construction and operation and is made from material usually found around a railroad shop, no special patterns having been required. It is used in cutting, splicing, mounting and stripping both air brake and signal hose, but one change being required for the performance of these operations.

The construction of the machine is clearly shown in the drawing. At one end of the table is a cutter *A*, operated by a vertical air cylinder which may be of any size desired.

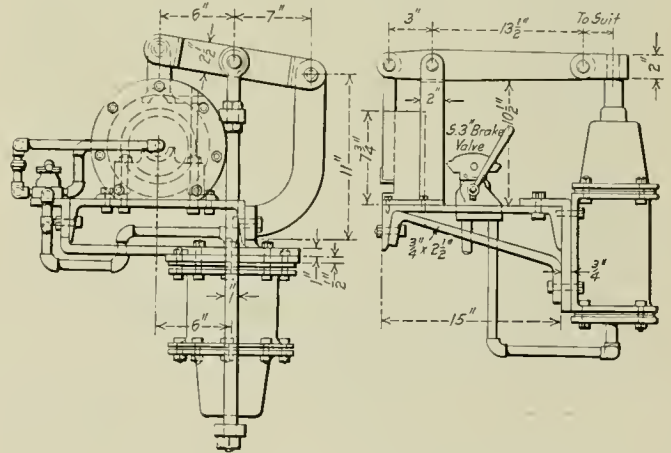

End Views of the Hose Stripping Machine

At the center are placed the clamps *B*, in which the hose is secured while having the coupling and nipple removed or applied. These clamps are operated by an 8-in. by 7-in. driver brake cylinder, the thrust of the push-rod being transmitted to the clamp-operating lever by means of the tension rods and yokes shown. The horizontal cylinders *C* and *D*, which are 8-in. by 12-in. brake cylinders, are used to remove and apply the coupling and nipple from the ends of the hose. The operation of each cylinder is controlled by a Westinghouse valve, the type of which is indicated on the drawing.

The first operation in stripping old hose is to cut the clamp bolt on the cutter *A*. The hose is then passed to another man who clamps it at *B* and pulls out the coupling

and nipple by means of the cylinders *C* and *D*. The hose clamps are then struck in the opening with a cross peen hammer to spread them so that they may be easily removed from the hose. While the hose is being stripped, all couplings, nipples and clamps, as well as the hose itself, are inspected, and are placed in boxes for future use. In mounting hose the clamps are first placed in position and the hose clamped in the machine. The coupling is then placed in the holder *E* and pressed into the end of the hose by the cylinder *C*. The nipple is placed in a holder on the piston rod of cylinder *D*, by means of which it is pressed into the hose. The holder *E* is used in both stripping and mounting work, but separate holders are required for use with cylinder *D* in the two operations.

After being mounted, the hose are piled on the end of the clamping machine, which is directly behind the mounting machine, where they are later clamped and the bolts applied, after which they are tested under air pressure. The clamping machine is a simple device in which the clamps are gripped and closed by means of an 8-in. by 8-in. air cylinder.

Two men do all the stripping and mounting of hose by means of this machine, including the handling of the hose to the machine and disposing of the parts after the hose has been stripped. They also do any repairing which is required by the clamps and couplings and count and rack the mounted hose. Under these conditions the following performance has been made: One man with a helper has mounted and tested 250 hose in a nine-hour working day.

### BOILER WASHER'S HOSE CART

BY E. A. MURRAY

Master Mechanic, Chesapeake & Ohio, Clifton Forge, Va.

It is not unusual to see the boiler washer dragging the washout hose through the roundhouse, and after he has succeeded in getting the hose to the point where it is to be used, it is necessary to return for the tools. By the use of one of

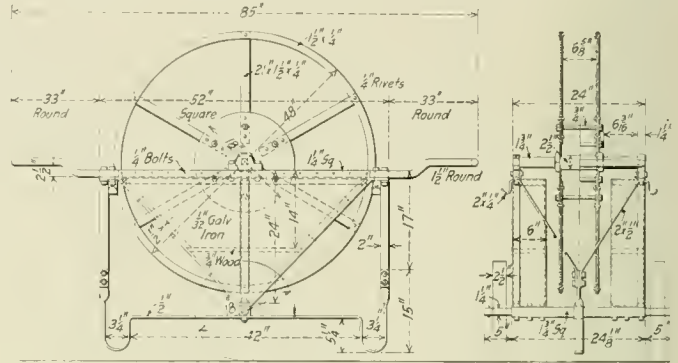

Washout Hose Car

these hose carts this trouble is eliminated, as it can easily be moved from place to place, and provides suitable means of transporting the washout hose and the other boiler washing tools.

It might be added that a pot of graphite mixed with valve

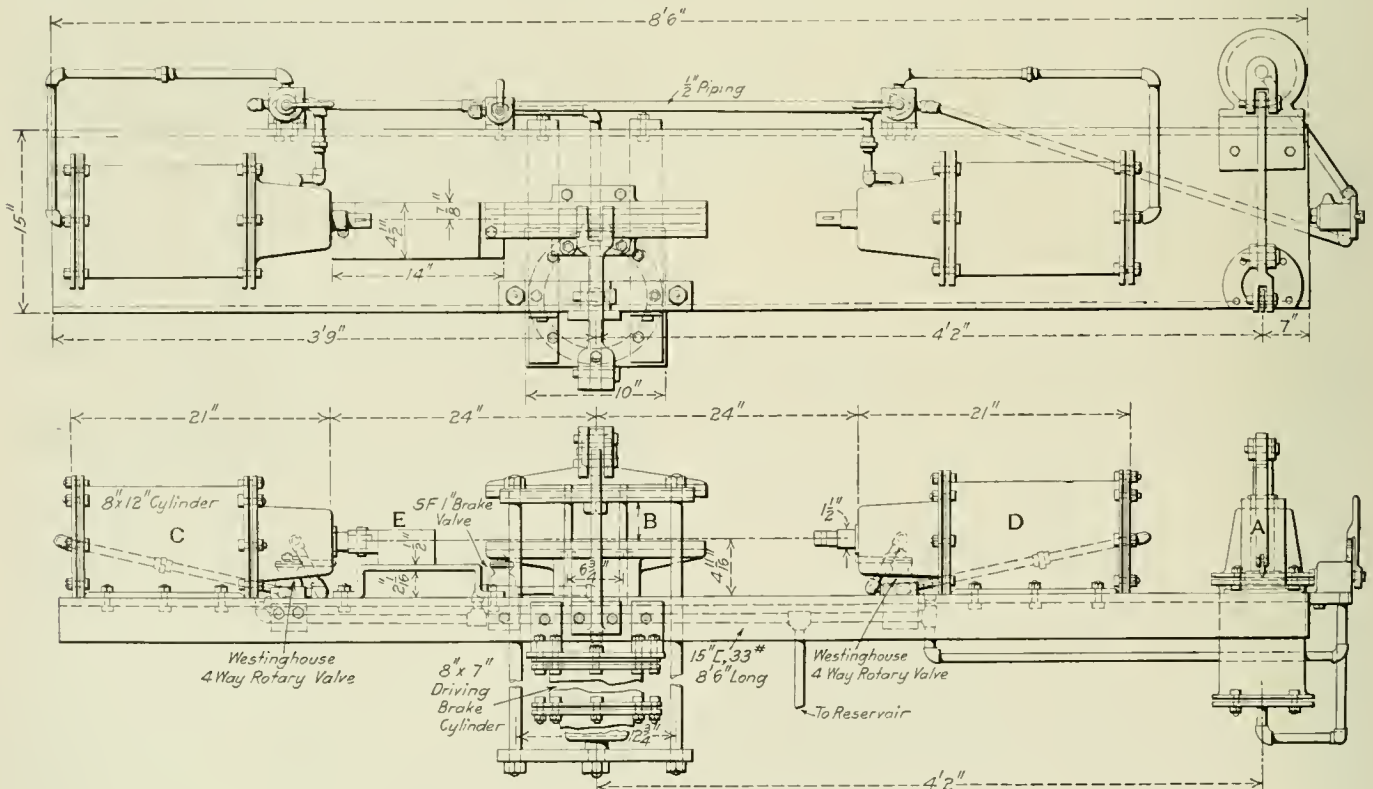

Machine for Stripping and Mounting Air Brake and Signal Hose

In stripping, one man and a helper will average 700 hose per day of nine hours. One man with a helper can splice 200 hose in a day of eight hours. One man with a helper will mount, on an average, 300 signal hose in eight hours.

oil is always in evidence with the outfit, this being used on the threads of washout plugs to make their removal easy. There is very generally not enough attention given to the importance of boiler washing.

**FEED-WATER TEMPERATURE WITH OPEN HEATERS.**—In an open feed-water heater the water to be heated is under atmospheric pressure and its temperature cannot be raised above 212 deg. F.—*Power.*

**FUEL BRIQUET INDUSTRY IN 1915.**—Over a million dollars' worth of briquets were made from waste coal in 1915, the exact production being 221,537 tons, valued at \$1,035,716.

# NEW DEVICES

## FUEL OIL DRIVEN AIR COMPRESSOR

To produce air compressors with lower operating costs and of lower first cost than any previously known has been the idea of the engineers of the Chicago Pneumatic Tool Company, Chicago, in the development of their Class N-SO fuel oil driven compressors.

These compressors are guaranteed to run on any mineral oil of 26 deg. Beaumé scale or lighter, containing not over one per cent sulphur. There are a number of oils well below this scale on which they will operate satisfactorily, but this depends upon the characteristics of the particular oil. A number of these fuels are obtainable for three cents per gallon, and the compressors are warranted to compress air to 100 lb. per sq. in. at a cost not exceeding 56 cents per day of nine hours for each 100 cubic feet per minute of free air delivered to the receiver. There are many of these machines in service with daily records of fuel consumption that bring their costs of operation well under the amount stated.

These compressors are of the horizontal, straight line, single stage type with compressing cylinder bolted to the main frames and closely connected in tandem to the power ends. The propulsive cylinders are of the valveless, two-cycle, low compression design. Ignition is produced by a

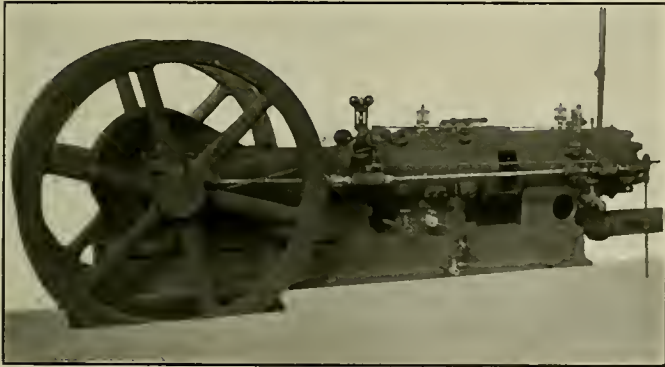

Air Compressor Using Oil as Fuel

patented, positive-acting hot-plate system, that eliminates all electric apparatus such as magnetos, timers, mixers, and spark plugs. As in the Diesel engine, combustion takes place at the end of the compression stroke. Air only is compressed in the cylinder, and combustion is so complete by the time the exhaust port is opened that the fuel loss is negligible. The result is attained through the medium of a small oil pump which injects the fuel against the hot plate on the piston as it approaches the end of the compression stroke. Increased economy is obtained by the use of water with the fuel oil. The quantity of both oil and water admitted to the combustion chamber is controlled by a fly-ball governor. The outstanding features of the compressing cylinders are the patented "Simplex" \* flat disc air inlet and discharge valves. They are guaranteed for three years.

N-SO compressors are made in both single and duplex types. Single compressors come in six standard strokes; 8, 10, 12, 14, 18 and 21 in. The smaller sizes may be tank mounted and the larger types set on skids so that their use is not confined to stationary requirements. The adaptability of these machines to severe service conditions renders

\*See *Railway Age Gazette Mechanical Edition* for October, 1915, page 545.

them particularly attractive to mines and contractors, but they are equally desirable for railroad and industrial shops, for pumping oil and water by various systems, and for use wherever cheap compressed air can be utilized.

## DRIVING BOX BRASS

The illustrations show a departure in sectional locomotive driving journal bearings or brasses. The Langton brass, of which there are now 270 in service, has been designed with a view to simplifying the operation of applying and removing such brasses. This operation, heretofore, has involved the shopping of the locomotive, dropping the wheels and otherwise dismantling, with an attendant expense, including the loss of the earning capacity of the locomotive, often amounting to \$125 or more. With the use of the Langton brass it is possible to crown a pair of journals in less than two hours, at a cost of less than \$3.00, without the use of a

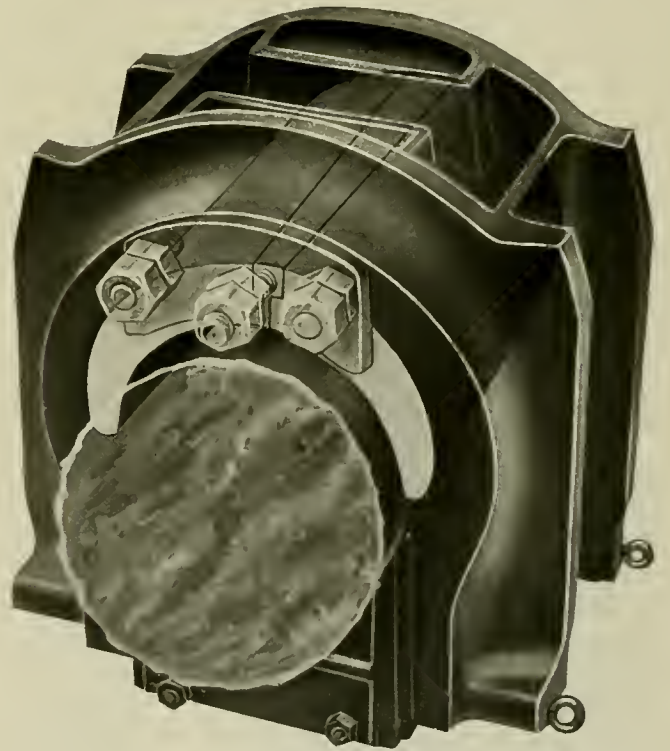

Langton Driving Box Brass

drop pit or any other facilities than a journal jack, making it possible to do the work during the lay-over period, consequently the locomotive need not miss its regular run. Brasses can be closed on the journal in less than 30 min.

No change of existing patterns of boxes or brasses is required. The solid brass is simply split lengthwise and provided with a tapered groove or key-way at the top to receive a tapered key or wedge which forms the adjusting means. A small holding plate fastened to the inside face of the box by means of two studs completes the arrangement. It can be manufactured at any shop having a lathe, planer or shaper, and drilling machine, and can be applied at any roundhouse.

In applying a solid brass the driving box, weighing sev-

eral hundred pounds, has to be handled and trucked a number of times, while with the Langton brass the heaviest part moved is the brass itself. This brass has been in service

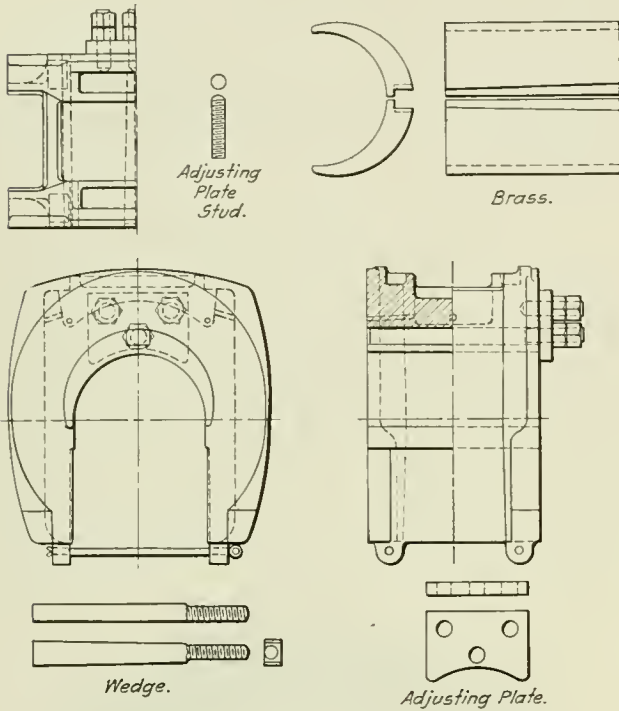

Details of the Construction of the Langton Brass

nearly two years on all classes of power and has demonstrated its entire practicability. It has been developed by J. W. Small and G. H. Langton, Portsmouth, Va.

### PYROMETER FOR MEASURING TEMPERATURE OF STEEL

The Gibb Instrument Company, Highland Bldg., Pittsburgh, Pa., has placed on the market a departure from the

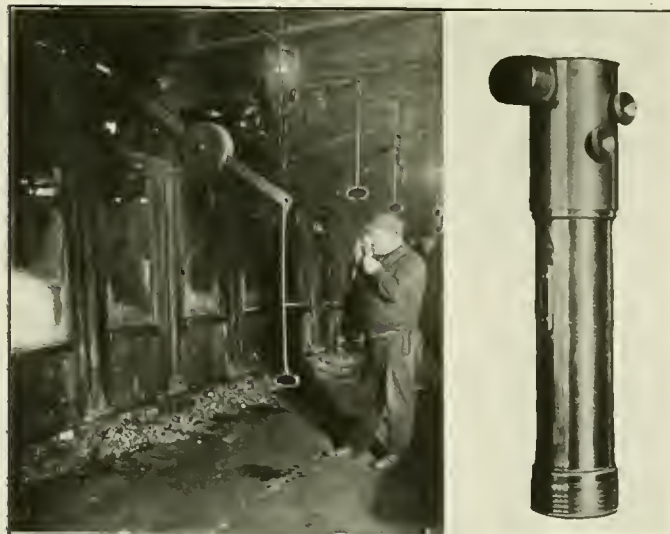

Pyrometer and Its Method of Use

ordinary thermo-electric pyrometer, known as the "I-Rite." Its principal claim for distinction is that while the thermo-electric pyrometer indirectly measures the temperature of the material under heat by measuring furnace temperatures, the new instrument directly measures the temperature of the

piece. The instrument is of pocket size, simple, accurate and inexpensive.

It is claimed that this pyrometer will exactly duplicate the color of heated bodies and at the same time indicate the temperature on an accurately calibrated scale. It is possible for the user to read the temperature of the piece under treatment within one to two per cent, regardless of the furnace temperature. It is not necessary to take into account the length of time the body has been subjected to the specified temperature in order that it may assume this temperature. The pyrometer immediately shows either that the piece is or is not up to temperature and, in the latter event, how many degrees it must be raised.

The operation is simple and the instrument can safely be placed in the hands of an unskilled workman. The construction is claimed to be such that it cannot get out of order. While it is designed for the more precise temperature measurements of high grade steels under treatment, inasmuch as it is made in two ranges, 1,000-1,800 deg. F. and 1,800-2,300 deg. F., it can also be used for taking the temperature of heated bodies either within or without a furnace.

### PORTABLE DRILLING AND TAPPING MACHINE

The portable, electrically operated drilling and tapping machine shown in the illustration, is handled by the Wiener Machinery Company, 50 Church St., New York. These machines are intended chiefly for use in locomotive repair

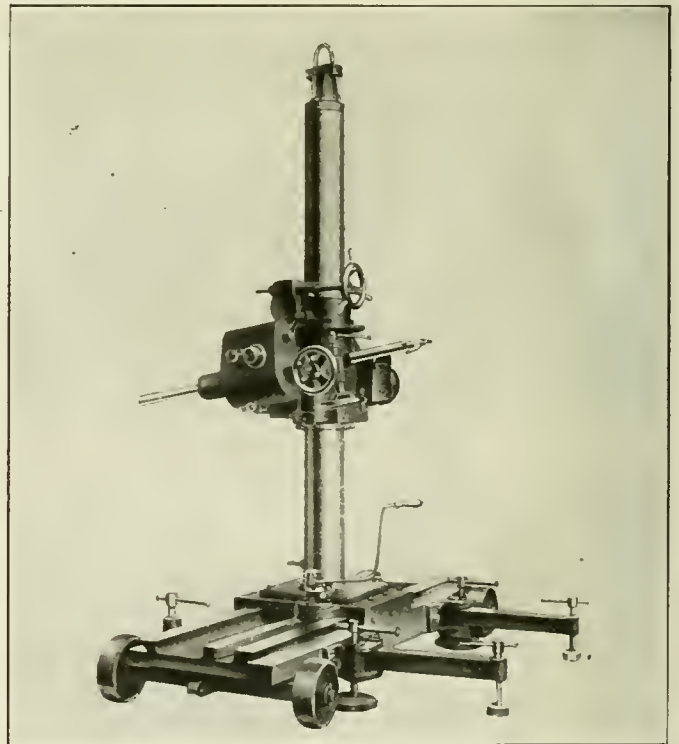

Portable Drilling and Tapping Machine

shops. They can be moved directly to the place where they are to be used and can be put into operation without any installation work. The fastening of the drill to the object to be drilled is avoided, and in the drilling of small and medium-sized holes the weight of the machine is enough to counteract the drilling pressure. For larger holes and in case the drillhead is on top of the column, the machine is supported by the turnable arms mounted on the bedplate. For fixing the machine to the floor, four heavy plate screws are provided.



The drilling spindle is driven by a three horsepower electric motor which is located near the drilling head. A double acting worm gear and a compound gear are provided so that four cutting speeds can be obtained. The drilling-head is turnable around the horizontal axis and can be swiveled 360 deg. around the column and also can be moved up and down; besides this the column with its foot-plate can be moved horizontally along the carriage bedplate. The spindle therefore can be adjusted in every direction. The machine drills holes up to 1½ in. into the solid and taps up to 1¼ in. By the use of a boring bar, holes up to 4 in. in diameter can be drilled. The up-and-down movement of the drilling gear on the column is accomplished by motor power.

### INTERCEPTING VALVE FOR MALLET LOCOMOTIVES

In the accompanying drawings are shown the details and method of operation of an intercepting valve which has recently been developed by the Economy Devices Corporation, New York, for use on Mallet compound locomotives. It is known as the Simplex intercepting valve and is shown as applied to cylinders which are cast integral with half saddles. It is enclosed in a separate lagged and jacketed casing in

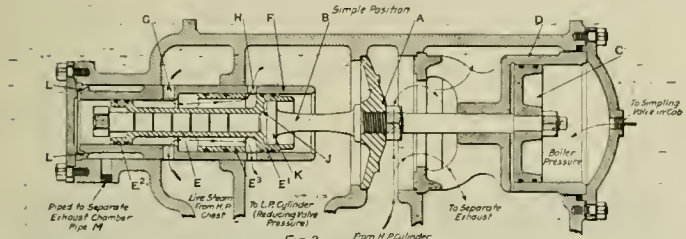
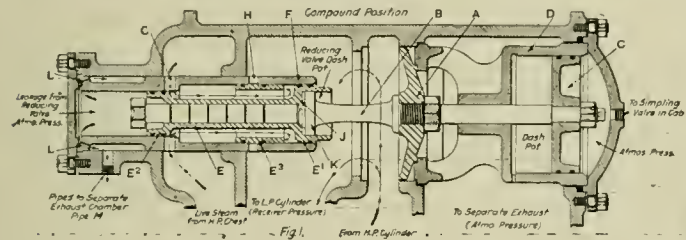

Sections Showing the Construction and Operation of the Simplex Intercepting Valve

front of the cylinders, with separate connections to each. This arrangement permits the use of the same pattern for both right and left cylinders, the openings in the rear walls being closed by special caps as shown in one of the illustrations. It may readily be adapted for use with cylinders which are attached to a separate saddle casting, in this case it being possible to provide the necessary passages and chambers for the operation of the valve inside the saddle itself.

By referring to the drawing showing the operating positions of the valve it will be seen that the casing is divided into four chambers communicating respectively from left to right with the live steam chamber of the high pressure steam chest, the receiver pipe, the exhaust passages of the high pressure cylinders and a separate exhaust pipe leading to a removable annular nozzle surrounding the main exhaust nozzle. The exhaust steam from the high pressure cylinders is controlled by the main valve *A* which causes it to flow into the receiver chamber and thence to the low pressure cylinders when the engine is working compound and through the separate exhaust chamber to the atmosphere when working simple. The intercepting valve stem on which this valve is secured is extended to the right, the end carrying a piston *C* operating in the cylinder *D*. Live steam is admitted to the

outer face of the piston by placing the operating valve in the cab in the position marked "Simple," thus forcing the operating parts into the position shown in Fig 2. The inner end of the cylinder serves as a dash pot and prevents shock in the movement of the valve.

At the left end of the valve stem is a differential piston valve *E* which controls the admission of live steam to the low pressure cylinders. This valve has a movement of one-half inch on the stem, the latter having a traverse of three inches. It works in a bushing through which are ports communicating with the live steam and receiver chambers, port *G* admitting live steam to the annular space between the two pistons and port *H* admitting live steam to the low pressure cylinders under control of the reducing valve.

Referring to Fig. 2, showing the intercepting valve in simple position, it will be seen that until pressure is built up in the receiver pipe the reducing valve will occupy the position shown, owing to the greater area of piston *E*<sup>1</sup> as compared with piston *E*<sup>2</sup>. As soon as the predetermined pressure has been built up in the receiver pipe, however, it reacts on the outer end of the piston *E*<sup>1</sup>, causing the valve to move to the left on the stem and closing port *H*. The width of the opening through this port will thus be automatically regulated to meet the requirements of the low pressure cylinders at a constant receiver pipe pressure.

When the pressure is released from cylinder *D* the tendency of the reducing valve to move to the right is utilized to move the main valve from its simple to its compound position. At the outset this movement is aided by the action of the receiver pipe pressure against the piston *A*. When the valve moves from simple to compound position the intermediate piston *E*<sup>3</sup> moves over the port *H* and closes it as shown in Fig. 1.

The control of the power exerted by the high pressure cyl-

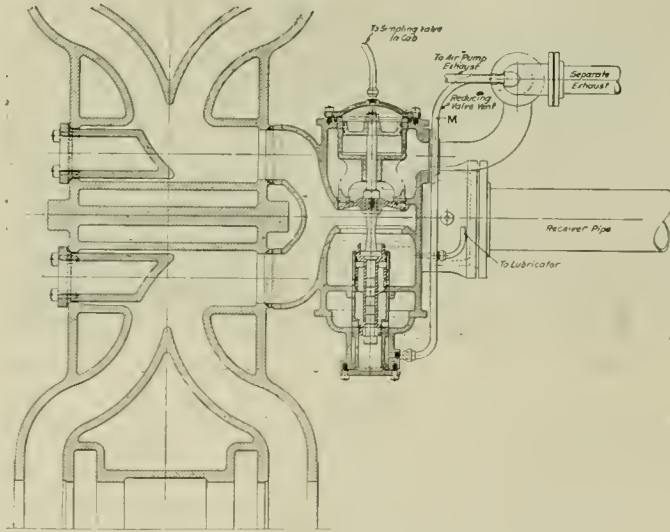

Sectional Plan of Cylinders with the Intercepting Valve in Place

inder when working simple is effected by changing the size of the annular exhaust nozzle. The small end of the reducing valve is vented to the atmosphere through the pipe *M* which leads into the high-pressure exhaust pipe. The smaller the exhaust nozzle the greater the back pressure acting on the high pressure piston; this in turn, acting through the pipe *M* against the small reducing valve piston, increases the receiver pipe pressure and adds power to the low pressure cylinder. Should the high pressure engines slip when working simple, the resulting increase in back pressure will produce the same effect, temporarily increasing the pressure admitted to the low pressure cylinders and thereby tending to maintain a uniform total drawbar pull.

Care has been taken in designing this valve to facilitate

removing it for inspection or repairs. The entire mechanism including the operating cylinder *D* may be removed by taking off the cylinder head, the arrangement being such that the work may be done from the ground without going between the locomotive frames. This work may be done with no other tools than a monkey wrench.

### KO-SHOVEL MECHANICAL STOKER

A new scatter type stoker for stationary boilers has been placed on the market by the Goetz Company, Chicago. The stoker is installed either directly in the upper portion of the fire door opening or immediately above the door in the boiler front. The entering chute and plunger occupy a space but 5 in. deep, and when installed in the fire door opening a new door is provided. The installation does not prevent, or interfere in any way with firing by hand, or cleaning the fire through the fire door. The coal is fed to the hopper of the stoker, as shown in the photograph, and from there passes through a pair of agitator crushers to a rotary coal valve. This valve regulates the flow of the crushed coal to the discharge cylinder, where it is ejected onto the grate by means of a spring actuated plunger, the coal passing over a water-

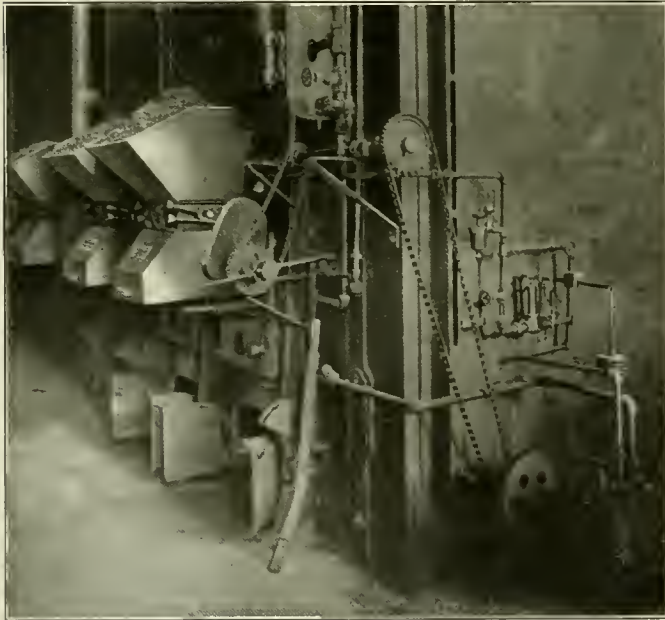

Ko-Shovel Mechanical Stoker Applied to a Battery of Boilers

cooled deflector suitably arranged to properly scatter the coal over the grate.

The rotary valve is simply a disc with two diametrically opposite pockets which take the correct amount of coal from the crusher chamber and deliver it to the discharge cylinder. The plunger is driven by two compression springs and is pulled out to the charging position by means of a cam, as indicated in the drawing. The gearing is so arranged that as the plunger is pulled back the rotary coal valve delivers its charge to the discharge cylinder. By the time the second cam roller disengages from the second lug on the plunger the rotary valve is closed and the coal is in the cylinder ready to be discharged. A compression spring is provided, as indicated, to serve as a buffer for the plunger at the end of the stroke.

The stoker may be driven by either a steam engine or an electric motor or by a belt from a line shaft. When a steam engine or motor is used the speed at which the stoker is operated may be regulated by an automatic regulator controlled by the pressure of the steam in the boiler. The coal hoppers are designed to hold one hour's supply of coal and the coal

is fed to the grate in one-half pound charges. This stoker will fire successfully any grade of fuel between 1½ in. bar screening and No. 5 washed or unwashed coal. With the stoker better combustion of the fuel is obtained, due to the

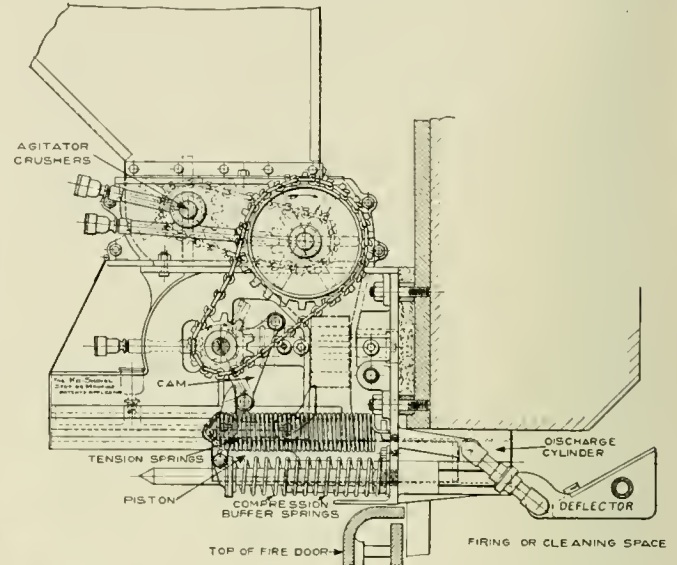

Section Through the Ko-Shovel Mechanical Stoker

fact that the charges are small and frequent and that the fine dust particles are completely burned almost before they reach the grate. Exclusive sales rights for this machine are held by George A. Kohout & Company, Monadnock building, Chicago.

### MOLDING METALLIC PACKING FOR SATURATED STEAM LOCOMOTIVES

It has long been the practice to machine all metallic packing to fit the vibrating cup, but errors are bound to creep in, even if the most perfect gages are used in the finishing. By means of the machine here shown, metallic packing can



Machine for Making Metallic Packing

be molded to the exact finished size ready to be cut and put in the vibrating cup. An allowance of  $\frac{1}{8}$  in. is made for piston or valve rod fit. This machine not only does away with bad fitting packing, but reduces the labor cost very materially, and in cases where leaks occur, the cause can be traced back to imperfect angles of the cup or to some other defect, instead of blaming the packing.

One of the illustrations shows a front and side elevation as well as a top view of plate .1, which is counterbored to receive the steel molds and rigidly held in position. The

side of the pistons, thereby causing plates *C* and *D* to move away from .1 allowing the operator to remove the packing from the molds. In order that the packing may be free from fins, the molds and plungers are set on springs *V*, which take up any variation in alignment between .1, *B* and *C*.

This machine has been in continuous service for six months and during this period one operator produced a daily average of 350 sets of packing. The dotted lines through .1 and marked "steam inlet" and "steam outlet" are passages for steam used to heat the dies and to keep the temperature uniform.

This device was developed by F. J. Dailey on the Erie Railroad and a patent has been applied for.

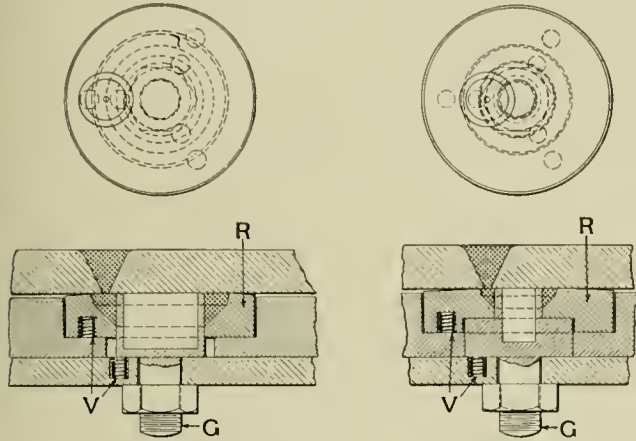

Arrangement of Moulds for Piston Rod Packing.

Arrangement of Moulds for Valve Stem Packing.

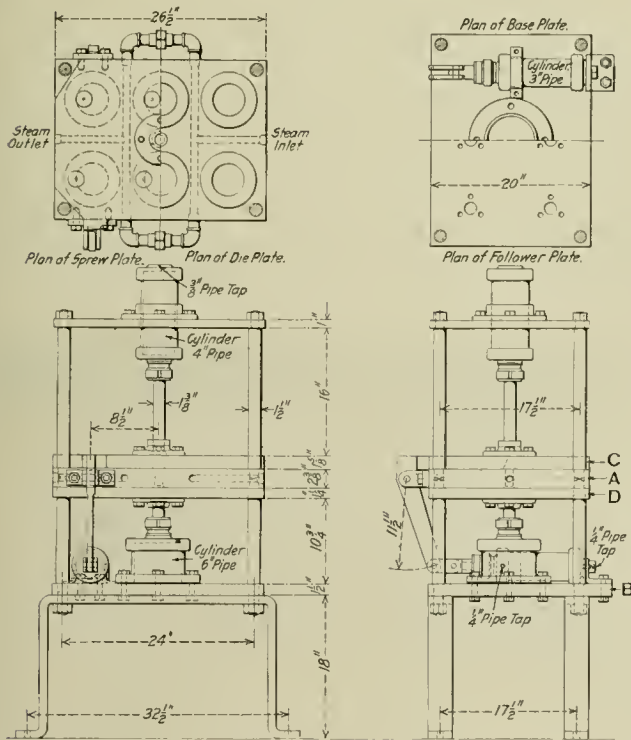

Details of Machine for Making Metallic Packing

pneumatic cylinder for shearing the gates is bolted to *B*. The machine can be operated either by steam or air but on account of the condensation from steam, air is preferable.

Two cylinders are used to raise and lower plates *C* and *D* by means of a four way valve which will allow air to pass into the head ends of both cylinders to close *C* and *D* against *A*, or the opposite sides of the pistons to open plates *C* and *D*. When *C* and *D* are closed against *A* and the plugs *G* and molds *R* are in proper place, the metal can be poured through the gates in the plate *C*. After the metal sets, plate *C* shears the gates and air is admitted to the rod

### PNEUMATIC PUNCH AND RIVETER

The pneumatic punch and riveter shown in the accompanying photograph may be used either as a portable or a stationary machine and is a tool which is suitable for any shop doing light punching or riveting. It has a punching capacity of  $\frac{3}{16}$  in. to  $\frac{1}{2}$  in. holes in  $\frac{1}{4}$  in. plate at 90 lb.

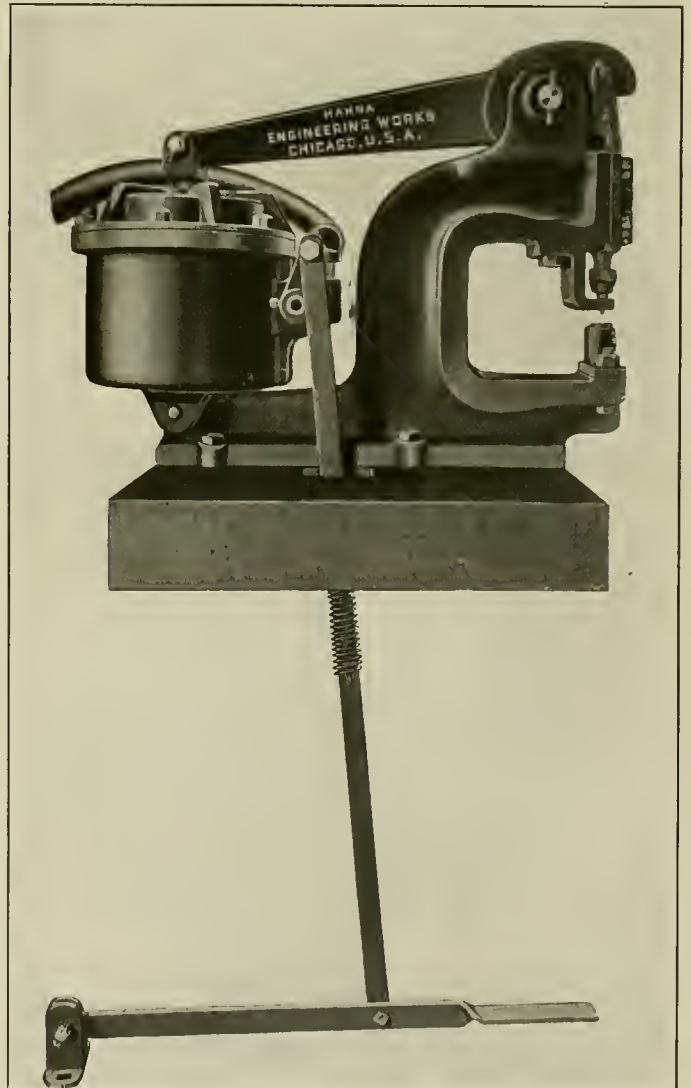

Pneumatic Machine for Light Punching and Riveting

air pressure and will satisfactorily drive  $\frac{1}{4}$  in. rivets cold. A specially designed cushion in the top head prevents shock after the punch has passed through the plate. The frame, the main lever and the plunger are steel castings, the cylinder

parts being chiefly of cast iron. The machine weighs 225 lb. and consumes 1.26 cu. ft. of free air per stroke. It is manufactured by the Hanna Engineering Works, and distributed through the Vulcan Engineering Sales Company, Chicago.

### TURBO-BLOWER

The Ingersoll-Rand Company, New York, has added to its turbo-compressors and blowers a low pressure machine for volumes of from 3,000 to 35,000 cu. ft. per minute at from 1 to 2½ lb. pressure. These are particularly adapted to such service as foundry cupola blowing, atomizing oil for

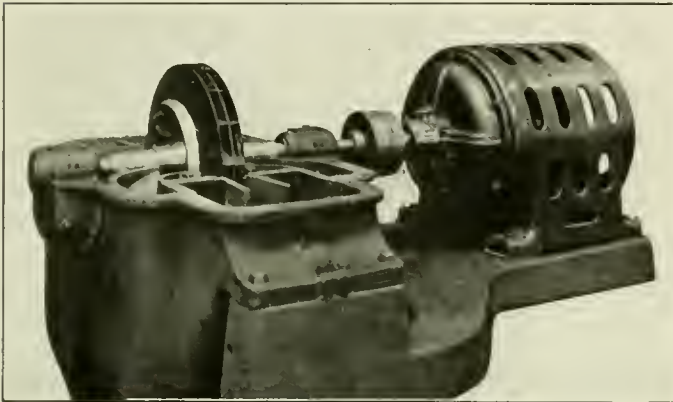

Low Pressure Type Turbo-Blower with Upper Casing Removed, Showing Double Flow Enclosed Impeller

oil burners, supplying blast to heating and annealing furnaces of various kinds, blowing air for water gas generators, pneumatic conveying and ventilating. They are of the single stage, double flow type and are furnished either electric motor, steam turbine or water wheel driven. Electric drive is



Ingersoll-Rand Low Pressure Type Turbo-Blower

generally employed for the classes of service mentioned and in the case of the I-R turbo-blower, the high operative speed permits direct coupling to the motor. This motor-driven blower maintains constant pressure while delivering any

volume from zero to maximum demand and proportionately varying the electrical horsepower input.

These blowers embody the four bearing construction featured in all turbo machines of this make. The casing is horizontally split for ease in installation and subsequent inspection. The assembled casing is doweled and bolted to a heavy sub-base which ordinarily serves for both blower and driving element. The I-R machine occupies small floor space and its lack of vibration in operation obviates the necessity for foundation bolting. The impeller is of the enclosed double flow type, which is claimed to secure the highest efficiency. The wheel is machined from a solid, special steel forging. The vanes and covers are of pressed steel securely riveted. All rivet heads are driven flush and the entire assembly is polished. Every care is taken to reduce skin friction. All impellers are over-speeded in a testing machine to insure correct balance, strength and eliminate vibration. Impellers are keyed to a heat treated, forged steel shaft. Labyrinth packing is employed to prevent leakage between impeller and casing. The bearings are ring oiled and both bearings and their housings are horizontally split. The use of flexible couplings between the blower and the driving unit is standard practice on all I-R turbo-blowers. The machines are all of the closed intake type. The intake opening is at the bottom and the discharge at the top. There are no rubbing surfaces in the I-R turbo-blower, precluding the necessity for adjustment to take up wear and minimizing the cost of maintenance. The only lubrication necessary is that of the bearings, all other parts working without friction. ---

### PROTECTING BLUE PRINT PAPER

The Security tube, shown in the illustration, has been brought out by Kolesch & Co., 138 Fulton St., New York, for storing and protecting blueprint paper, tracing linen and drawing paper. The tube is made in three lengths, 30, 36 and 42 in., of heavy tin japanned black. It tends to eliminate waste and loss of time and avoids the inconvenience of opening and closing the tube every time paper or cloth is required. The paper is placed in the tube by pushing back the slide cover and closing it, the paper remaining protected

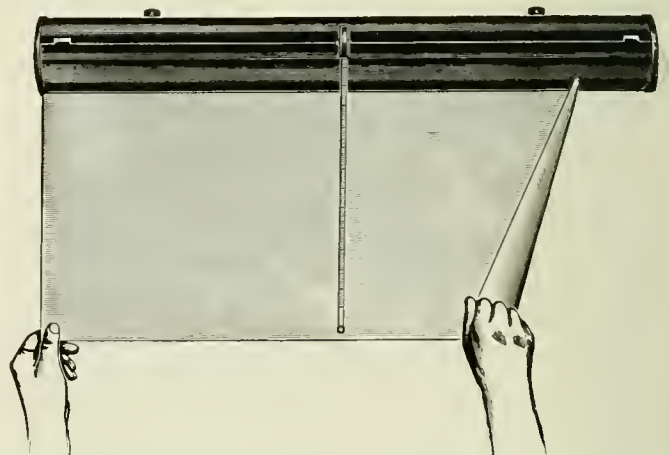

Container for Blue Print Paper and Tracing Linen

without again opening the tube until the entire roll has been used.

When a sheet of specified length is to be used, a spring measuring tape, which is attached to the tube, is drawn to the required length, the paper or cloth drawn out and cut by means of a straight cutting edge provided for the purpose.

The tube is provided with brackets so that it can be fastened to the wall, or it may be fastened to a drafting table, as desired.

# Railway Mechanical Engineer

(Formerly the RAILWAY AGE GAZETTE, MECHANICAL EDITION with which the AMERICAN ENGINEER was incorporated)

PUBLISHED ON THE FIRST THURSDAY OF EVERY MONTH BY THE SIMMONS-BOARDMAN PUBLISHING COMPANY

EDWARD A. SIMMONS, *President*                      L. B. SHERMAN, *Vice-President*  
 HENRY LEE, *Vice-President and Treasurer*      M. H. WIUM, *Secretary*  
 WOOLWORTH BUILDING, NEW YORK, N. Y.

Chicago: Transportation Bldg.                      Cleveland: Citizens' Bldg.  
 London: Queen Anne's Chambers, Westminster.

Roy V. WRIGHT, *Editor*  
 A. C. LOUDON, *Managing Editor*  
 R. E. THAYER, *Associate Editor*                      C. B. PECK, *Associate Editor*

Entered at the Post Office at New York, N. Y., as mail matter of the second class.

Subscriptions, including the eight daily editions of the *Railway Age Gazette* published in June in connection with the annual conventions of the Master Car Builders' and American Railway Master Mechanics' Associations, payable in advance and postage free: United States, Canada and Mexico, \$2.00 a year; Foreign Countries (excepting daily editions), \$3.00 a year; Single Copy, 20 cents.

WE GUARANTEE, that of this issue 8,800 copies were printed; that of these 8,800 copies, 7,512 were mailed to regular paid subscribers, 100 were provided for counter and news companies' sales, 411 were mailed to advertisers, exchanges and correspondents, and 777 were provided for new subscriptions, samples, copies lost in the mail and office use; that the total copies printed this year to date were 40,500, an average of 8,100 copies a month.

The RAILWAY MECHANICAL ENGINEER, and all other Simmons-Boardman publications are members of the Audit Bureau of Circulations.

VOLUME 90                      MAY, 1916                      NUMBER 5

## CONTENTS

EDITORIALS:

- Saving Weight to Provide Boiler Capacity..... 219
- The Car Terminal Competition..... 219
- Cleaning Passenger Cars..... 219
- The Fireman and Boiler Capacity..... 219
- Specializing Enginehouse Work..... 220
- England's Idea of the Steel Passenger Car..... 220
- Altering Locomotive Front Ends..... 220
- Railway Mechanical Conventions..... 220
- The Responsibility of Car Inspectors..... 221
- Getting the Most Out of Locomotives..... 221
- New Books ..... 221

COMMUNICATIONS:

- A Word for the Efficiency Engineer..... 222
- The Mechanical Department Clerk..... 222

GENERAL:

- Locomotives of the Santa Fe Type..... 223
- Prevention of Corrosion in Pipe..... 227
- Test of the Young Valve and Valve Gear..... 229
- Express Locomotives in France..... 231
- Grease Lubrication of Locomotive Driving Boxes..... 234
- Examples of Recent Locomotives..... 235

CAR DEPARTMENT:

- Portable Scaffold for Car Repair Tracks..... 237
- Numbering Repair Parts of Cars..... 237
- Passenger Terminal Inspection..... 239
- The Sanitation of Railway Cars..... 241
- Northern Pacific Express Cars..... 243
- The Cause of Slid Flat Wheels..... 247
- Systematic Repairs to Freight Equipment..... 248

SHOP PRACTICE:

- Interesting Boiler Shop Devices..... 249
- Efficiency in Scheming..... 250
- Spokes in the Roundhouse Wheel..... 251
- Cleaning Lighting Fixtures..... 253
- Forge Shop Practice..... 253
- Piston Valve Packing Rings..... 254
- What the Boys Think of Apprenticeship..... 255
- A Double Thermit Weld..... 257

- The Maintenance of the Locomotive Boiler..... 257
- Portable Tire Heater..... 258
- Waste Storage Can..... 259
- What Can Be Done for the Apprentice..... 259
- Hose Stripping Machine..... 259
- Boiler Washer's Hose Cart..... 260

NEW DEVICES:

- Fuel Oil Driven Air Compressor..... 261
- Driving Box Brass..... 261
- Pyrometer for Measuring Temperature of Steel..... 262
- Portable Drilling and Tapping Machine..... 262
- Intercepting Valve for Mallet Locomotives..... 263
- Ko-Shovel Mechanical Stoker..... 264
- Molding Metallic Packing for Saturated Steam Locomotives..... 264
- Pneumatic Punch and Riveter..... 265
- Turbo-Blower ..... 266
- Protecting Blue Print Paper..... 266

NEWS DEPARTMENT:

- Notes ..... 267
- Meetings and Conventions..... 268
- Personals ..... 269
- Supply Trades Notes ..... 270
- Catalogues ..... 272

# NEWS DEPARTMENT

## CORRECTION

In the article on the "Diameter of Driving Axle Journals" by L. R. Pomeroy, in the April number, a typographical error appears in the footnote in the second column on page 171. The character surrounding the expression for the diameter of axle *d* should indicate the cube root and not the square root.

## ORDERS FOR CARS AND LOCOMOTIVES IN APRIL

The orders for cars and locomotives in April were considerably below the average which had been set during the last quarter of 1915 and the first quarter of the present year. It is becoming evident that the high prices for steel and other materials going into the construction of railway equipment are acting as a damper on the equipment market. The orders reported during the month were as follows:

	Locomotives	Freight Cars	Passenger Cars
Domestic .....	178	7,228	101
Foreign .....	12	1,000	...
	190	8,228	101

Among the important locomotive orders were the following:

Road	No.	Type	Builder
Chicago Great Western.....	3	Pacific	Baldwin
	7	Santa Fe	Baldwin
Norfolk & Western.....	20	Mallet	American
Philadelphia & Reading....	20	Mikado	Baldwin
	6	Mallet	Baldwin
St. Louis & San Francisco..	10	Pacific	Baldwin
St. Louis Southwestern....	20	.....	Baldwin
Southern .....	30	Santa Fe	Baldwin
	15	Mountain	Baldwin
Pekin Hankow (China)....	10	Consolidation	American

Of the 7,228 freight cars ordered for domestic service, 3,857 were on orders placed by the Southern Railway as follows: 1,750 box cars, American Car & Foundry Company; 1,500 box cars, Mount Vernon Car Manufacturing Company; and 1,007 box, 500 automobile and 100 caboose cars, Lenoir Car Works. The Wabash placed an order for 1,000 box car bodies with the American Car & Foundry Company.

The Southern Railway ordered nearly all the 101 passenger cars reported during the month, that company having given the Pullman Company an order for 92 cars, including 45 coaches, 13 passenger and baggage cars, 19 baggage and express cars, 10 mail and baggage cars and 5 club cars.

## THE JUNE CONVENTIONS

Oscar F. Ostby, president of the Railway Supply Manufacturers' Association, has named the following as members of the nominating committee: George M. Basford, Loco-

motive Pulverized Fuel Company, New York; Charles C. Pierce, General Electric Company, Boston, Mass.; B. E. D. Stafford, Flannery Bolt Company, Pittsburgh; Harry Frost, Frost Railway Supply Company, Detroit; L. F. Wilson, Bird-Archer Company, Chicago; George L. Morton, Galena Signal Oil Company, Atlanta, Ga., and Clarence H. Howard, Commonwealth Steel Company, St. Louis.

In addition to the officers, nominations will have to be submitted for five members of the executive committee. These will succeed in the first district: C. B. Yardley, Jr., Lubricating Metals Company, New York, and J. C. Currie, Nathan Manufacturing Company, New York, who are retiring members; in the third district, C. E. Postlethwaite, Pressed Steel Car Company, who retires on account of having moved from Pittsburgh to New York, or out of the district; in the fourth district, C. F. Elliott, Acme White Lead & Color Works, Detroit, whose term will have expired, and in the fifth district, Joseph H. Kuhns, Republic Rubber Company, Chicago, whose term also expires.

**MEETINGS AND CONVENTIONS**

*American Railroad Master Tinnners', Coppersmiths' and Pipefitters' Association.*—The fourth annual convention of this association will be held at the Hotel Sherman, Chicago, on May 22-24. The following subjects will be considered: Sheet Metal Work and Machinery; Acetylene in the Tin Shop; The Use and Abuse of Pipe Fittings; Wrought Iron and Steel Pipe; Standard Piping and Clamping; Jackets; Ventilation and Heating of Steel Coaches; Oil Burning Engines and Appliances; Smoke Prevention Devices; Shop Practice; Concentration and Lost Motion.

*American Railway Tool Foreman's Association.*—The convention of the American Railway Tool Foreman's Association will be held on August 24-26, at the Hotel Sherman, Chicago. The following subjects will be presented by the committees: Heat Treatment of Steel, Henry Otto, chairman; Special Tools for Steel Car Repairs—Devices for Reclaiming Material, J. W. Pike, chairman; Special Tools and Devices for the Forge Shop, G. W. Smith, chairman; Emery Wheels as Applied to Locomotive Repairs, A. Sterner, chairman; Jigs and Devices for Enginehouses, F. D. West, chairman.

*Master Boiler Makers' Association.*—The tenth annual convention of the Master Boiler Makers' Association will be held at the Hotel Hollenden, Cleveland, Ohio, on May 23-26, 1916. The following is a list of the subjects to be presented and the committee chairmen: Cleaning and Maintaining Superheater Tubes, T. F. Powers; Removing and Replacing Wide Fireboxes, B. F. Sarver; Basic or Acid Steel for Fireboxes, James C. Clark; Cleaning Boilers with Tubes Removed, George Austin; Cracking of Barrel Sheets, C. R. Bennett; Bulging of Front Tube Sheets, J. B. Tate; Advantage of Cutting Off Stay Ends with Oxy-acetylene, Thomas Lewis; Rules for Arriving at Maximum Heating Surface, C. P. Patrick; Fusible Plugs in Crown Sheets, A. R. Hodges; Standard Thickness of Copper Ferrules for Good and Bad Water Districts, W. H. Laughridge; Do Long Tubes Vibrate

in Service, C. L. Hempel; Oxy-acetylene and Its Advantages in Boiler Repairs, John Harthill; Electric Welding and Its Advantages in Boiler Repairs, P. F. Gallagher; Prevention of Cracking in Side Sheets, T. P. Madden.

*International Railway Fuel Association.*—The eighth annual convention of the International Railway Fuel Association will be held on May 15-18, at the Hotel Sherman, Chicago. The following is a list of the papers to be discussed and their authors: Care of Locomotives and Boilers with Relation to Fuel Economy, A. N. Willsie; Psychology of the Fireman, Ralph Bradley; Interpretation of Coal Analysis with Special Reference to Non-Combustibles, E. G. Bailey; The Transportation Department and Fuel Economy, W. H. Averell; The Functions of a Railroad Fuel Inspector, E. McAuliffe; Method of Illustrating Value of Components of Coal, A. G. Kinyon; Fuel Distribution Record System, J. G. Crawford. There are also the following committee reports: Powdered Coal; Fuel Stations; Storage of Coal; Fuel Accounting; Firing Practice; Fuel Tests; Front Ends, Ash Pans and Grates. It is not yet known who will make the opening addresses. At the banquet which will be given on May 17, George A. Post, president of the Railway Business Association, will deliver the address of the evening. At other times during the convention addresses will be made by M. P. Blauvelt, controller, Illinois Central Railroad; Samuel O. Dunn, editor, *Railway Age Gazette*, and J. W. Higgins, chairman, General Managers' Association, Chicago.

*The following list gives names of secretaries, dates of next or regular meetings and places of meeting of mechanical associations:*

- AIR BRAKE ASSOCIATION.—F. M. Nellis, Room 3014, 165 Broadway, New York City. Convention, May 2-5, 1916, Hotel Ansley, Atlanta, Ga.
- AMERICAN RAILROAD MASTER TINNERS', COPPERSMITHS' AND PIPEFITTERS' ASSOCIATION.—W. E. Jones, C. & N. W., 3814 Fulton St., Chicago. Convention, May 22-24, Hotel Sherman, Chicago.
- AMERICAN RAILWAY MASTER MECHANICS' ASSOCIATION.—J. W. Taylor, Karpen Building, Chicago. Convention, June 19, 1916, Atlantic City, N. J.
- AMERICAN RAILWAY TOOL FOREMEN'S ASSOCIATION.—Owen D. Kinsey, Illinois Central, Chicago. Convention, August 24-26, 1916.
- AMERICAN SOCIETY FOR TESTING MATERIALS.—Prof. E. Marburg, University of Pennsylvania, Philadelphia, Pa. Convention, June 27-30, Traymore Hotel, Atlantic City, N. J.
- AMERICAN SOCIETY OF MECHANICAL ENGINEERS.—Calvin W. Rice, 29 W. Thirty-ninth St., New York.
- ASSOCIATION OF RAILWAY ELECTRICAL ENGINEERS.—Joseph A. Andreucetti, C. & N. W., Room 411, C. & N. W. Station, Chicago. Semi-annual meeting, Hotel Denis, Atlantic City, N. J., June 16.
- CAR FOREMEN'S ASSOCIATION OF CHICAGO.—Aaron Kline, 841 Lawlor Ave., Chicago. Second Monday in month, except June, July and August, Hotel La Salle, Chicago.
- CHIEF INTERCHANGE CAR INSPECTORS' AND CAR FOREMEN'S ASSOCIATION.—W. R. McMunn, New York Central, Albany, N. Y. Convention, October 3-5, Indianapolis, Ind.
- INTERNATIONAL RAILWAY FUEL ASSOCIATION.—J. G. Crawford, 547 W. Jackson Blvd., Chicago. Convention, May 15-18, Hotel Sherman, Chicago.
- INTERNATIONAL RAILWAY GENERAL FOREMEN'S ASSOCIATION.—William Hall, 1126 W. Broadway, Winona, Minn. Convention, August 29-31, 1916, Hotel Sherman, Chicago.
- INTERNATIONAL RAILROAD MASTER BLACKSMITHS' ASSOCIATION.—A. L. Woodworth, Lima, Ohio. Convention, August 15-17, 1916, Hotel Sherman, Chicago.
- MASTER BOILER MAKERS' ASSOCIATION.—Harry D. Vought, 95 Liberty St., New York. Convention, May 23-26, 1916, Hollenden Hotel, Cleveland, Ohio.
- MASTER CAR BUILDERS' ASSOCIATION.—J. W. Taylor, Karpen Building, Chicago. Convention, June 14, 1916, Atlantic City, N. J.
- MASTER CAR AND LOCOMOTIVE PAINTERS' ASSOCIATION OF U. S. AND CANADA.—A. P. Dane, B. & M., Reading, Mass. Convention, September 12-14, 1916, "The Breakers," Atlantic City, N. J.
- NIAGARA FRONTIER CAR MEN'S ASSOCIATION.—E. Frankenberger, 623 Brisbane Building, Buffalo, N. Y. Meetings, third Wednesday in month, New York Telephone Bldg., Buffalo, N. Y.
- RAILWAY STOREKEEPERS' ASSOCIATION.—J. P. Murphy, Box C, Collinwood, Ohio. Convention, May 15-17, 1916, Hotel Statler, Detroit, Mich.
- TRAVELING ENGINEERS' ASSOCIATION.—W. O. Thompson, N. Y. C. R. R., Cleveland, Ohio. Convention, September 5-8, 1916, Chicago.

**RAILROAD CLUB MEETINGS**

Club.	Next Meeting	Title of Paper	Author	Secretary	Address
Canadian .....	May 9	Annual Meeting; Election of Officers....	.....	James Powell .....	St. Lambert, Que.
Central .....	May 11	Modern Superheaters.....	S. S. Riegel.....	Harry D. Vought.....	95 Liberty St., New York
Cincinnati .....	May 9	Locomotive Feed Water Treatment.....	L. F. Wilson.....	H. Boutet .....	101 Carew Bldg., Cincinnati, O.
New England .....	May 9	.....	.....	Wm. Cade, Jr.....	683 Atlantic Ave., Boston, Mass.
New York .....	May 19	Lighterage .....	H. L. Joyce.....	Harry D. Vought.....	95 Liberty St., New York
Pittsburgh .....	May 26	Advantages of Railroad Test Department.	C. D. Young.....	J. B. Anderson.....	207 Penn Station, Pittsburgh, Pa.
Richmond .....	May 8	Automatic Stop and Train Control.....	Stephen Smith.....	F. O. Robinson.....	C. & O. Ry., Richmond, Va.
St. Louis .....	May 12	Tests of Bridge Timbers and Ties.....	H. F. Weiss.....	B. W. Fruenthal.....	Union Station, St. Louis, Mo.
South'n & S'w'rn .....	.....	.....	.....	A. J. Merril.....	Box 1205, Atlanta, Ga.
Western .....	.....	.....	.....	Jos. W. Taylor.....	1112 Karpen Bldg., Chicago.

## PERSONAL

### GENERAL.

H. D. CAMERON has been appointed mechanical engineer of the Canadian Northern, with office at Toronto, Ont.

M. JEFFERSON, assistant master mechanic of the New Jersey and Lehigh division of the Lehigh Valley at Easton, Pa., has been appointed master mechanic of the Auburn division at Auburn, N. Y.

A. T. KUEHNER has been appointed motive power inspector of the main line district of the Baltimore & Ohio.

THOMAS LEWIS, master mechanic of the Auburn division of the Lehigh Valley at Auburn, N. Y., has been appointed general boiler inspector for the system, with headquarters at Sayre, Pa.

H. H. MAXFIELD, master mechanic of the Pittsburgh division of the Pennsylvania Railroad, has been appointed superintendent of motive power of the Western Pennsylvania division.

W. J. O'NEILL, master mechanic of the Chicago, Rock Island & Pacific, at Shawnee, Okla., has been appointed mechanical superintendent of the Second district, with office at El Reno, Okla., succeeding R. L. Stewart, deceased.

E. S. PEARCE has been appointed assistant mechanical engineer of the Cleveland, Cincinnati, Chicago & St. Louis at Beech Grove, Ind. Mr. Pearce graduated from Purdue University as a mechanical engineer, and then entered the machine department of Jos. T. Ryerson & Son, Chicago. He got his first railway experience in the motive power and maintenance of way departments of the Norfolk & Western Railway at Portsmouth, Ohio. For the last two years he has been engaged in special work in the motive power department of the Cleveland, Cincinnati, Chicago & St. Louis, which position he leaves to accept his new appointment.

F. P. PFAHLER has been appointed motive power inspector of the Baltimore & Ohio at Baltimore, Md.

L. K. SILLCOX has been appointed mechanical engineer of the Illinois Central in charge of car work. Mr. Sillcox was born April 30, 1886, at Germantown, Pa., and was educated at Trinity School, New York, and the Mechanical and Electrical Institute of Brussels. He entered the High Bridge shops of the New York Central as an apprentice in 1903, leaving there in 1906 to go to the McSherry Manufacturing Company, at Middletown, Ohio. In 1909 he resigned from that company as assistant shop superintendent. He was then made shop engineer of the Canadian Car & Foundry Company at Montreal, leaving in 1912 to become chief draftsman of the Canadian Northern, which position he resigned to go with the Illinois Central.

### MASTER MECHANICS AND ROAD FOREMEN OF ENGINES

J. BUTLER has been appointed assistant master mechanic of the Cleveland, Cincinnati, Chicago & St. Louis at Bellefontaine, Ohio.

FRANK S. COOPER has been appointed general foreman of the locomotive department of the Baltimore & Ohio at Newark, Ohio, succeeding J. T. Gethens, promoted.

OSCAR CULBRETH has been appointed road foreman of engines for the Cairo division of the Cleveland, Cincinnati, Chicago & St. Louis at Mt. Carmel, Ill.

G. K. GALLOWAY has been appointed assistant master mechanic of the Baltimore & Ohio, at Glenwood, Pa.

J. T. FLAVIN, master mechanic of the Chicago, Indiana &

Southern at Gibson, Ind., has been appointed master mechanic of the New York Central at Elkhart, Ind., succeeding M. D. Franey. He will have charge of the fourth district.

P. L. DRESCHER has been appointed master mechanic of the Evansville & Indianapolis with headquarters at Terre Haute, Ind. Mr. Drescher was born in New York City on



P. L. Drescher

July 24, 1868. He received a high school education and entered railroad service in March, 1888, as a machinist with the Louisville, Evansville & St. Louis, now a part of the Southern Railway. After serving 10 years in this capacity he became machine shop foreman and in April, 1901, was appointed general foreman at Princeton, Ind. In July, 1902, he was transferred to Louisville, Ky., as general foreman, serving there until May, 1904, when he left railroad service to engage in business at Princeton, Ind. In September, 1906, he entered the service of the St. Louis, Iron Mountain & Southern as division foreman at McGehee, Ark. A year later he left this road to become roundhouse foreman on the Chicago & Eastern Illinois at Villa Grove, Ill., in which capacity he served until April, 1911, when he was appointed general foreman at Villa Grove. He left the service of the Chicago & Eastern Illinois in May, 1914, subsequently going with the Big Four at Mt. Carmel, Ill., where he remained until his recent appointment as master mechanic of the Evansville & Indianapolis.

P. C. MOSHISKY, whose appointment as master mechanic of the Rio Grande Southern at Ridgway, Colo., was announced in these columns last month, was born on December 27, 1883, at Marysville, Kan., and was education in the public schools of his native state and in the Marysville Normal College. In 1901 he entered the service of the Denver & Rio Grande in the stationery department and later served in the purchasing agent's office. In 1904 he started serving an apprenticeship as a machinist with the same company, also taking a course in mechanical drawing. He was later employed as a machinist on the Colorado & Southern and in the United



P. C. Moshisky

States reclamation service on the Gunnison Tunnel. In 1909 he entered the service of the Rio Grande Southern at Ridgway, Colo., as a machinist and in April, 1910, was appointed enginehouse and shop foreman at that point. In

September, 1911, he was appointed general foreman at Durango, Colo., and in March, 1916, he was appointed master mechanic of the Rio Grande Southern at Ridgway, Colo.

J. T. GETHENS, who has been general foreman, locomotive department, of the Baltimore & Ohio, at Newark, Ohio, has been appointed assistant master mechanic at Baltimore, Md.

#### CAR DEPARTMENT

H. E. PIERCE has been appointed general car foreman of the Illinois Central at Weldon passenger yard, Chicago, succeeding M. H. Long, deceased.

E. OPIE has been appointed car foreman of the Grand Trunk Pacific at Endako, B. C., succeeding H. Saunders, transferred.

H. SAUNDERS, formerly car foreman of the Grand Trunk Pacific at Endako, B. C., has been appointed car foreman at Biggar, Sask., succeeding H. E. Jell, who has left the company's service.

H. J. WHITE, heretofore supervisor of car work of the Canadian Northern at Toronto, has been appointed general car foreman of the National Transcontinental at Cochrane, Ont., with territory from Quebec, Que., to Graham, Ont.

#### SHOP AND ENGINE HOUSE

H. E. BENNETT has been appointed superintendent of shops of the Chicago, Terre Haute & Southeastern at Bedford, Ind.

E. G. CROMWELL has been appointed general foreman of the Baltimore & Ohio at Cumberland, Md.

J. HONAN has been appointed locomotive foreman of the Grand Trunk Pacific, at Calgary, Alta., succeeding F. Lozo.

F. J. LOZO, formerly locomotive foreman of the Grand Trunk Pacific at Calgary, Alta., has been appointed locomotive foreman at Wainwright, Alta., succeeding W. W. Yeager, transferred.

H. WALKER, heretofore night locomotive foreman of the Canadian Pacific at Schreiber, Ont., has been appointed locomotive foreman at White River, Ont., succeeding F. H. Hetherington, who has enlisted for active service.

#### PURCHASING AND STOREKEEPING

I. H. HARSH has been appointed purchasing agent of the Duluth, South Shore & Atlantic and the Mineral Range, with office at Duluth, Minn., succeeding P. W. Brown, who has retired from service.

H. A. SPIERS, formerly fuel agent of the Canadian Pacific at Vancouver, B. C., has been appointed assistant storekeeper there.

#### OBITUARY

JAMES F. WALSH, who was general superintendent of motive power of the Chesapeake & Ohio from May 1, 1910, to July, 1912, died suddenly of apoplexy at the Hotel Roanoke, in Roanoke, Va., on April 13. He was born in March, 1857, at Cleveland, Ohio, and began railway work in 1871 on the Cleveland, Columbus, Cincinnati & Indianapolis, now a part of the Cleveland, Cincinnati, Chicago & St. Louis. From 1871 to 1892 he was consecutively apprentice, locomotive fireman, locomotive engineman and shop foreman. Mr. Walsh left railway work in 1892 to become mechanical expert for the Galena Oil Company, but returned to railway service 10 years later as superintendent of motive power on the Chesapeake & Ohio. In May, 1910, he was promoted to general superintendent of motive power at Richmond, Va., and on July 1, 1912, retired from the active duties of that office, but later served in a consulting capacity on the same road. At the time of his death Mr. Walsh was on a business trip to Roanoke for the Galena Oil Company.

## SUPPLY TRADE NOTES

The main offices of the S. K. F. Ball Bearing Company have been moved from New York to Hartford, Conn.

The Baldwin Locomotive Works has moved its New York office from 50 Church street to the Equitable building, 120 Broadway.

The Robinson Connector Company has removed its office from New Haven, Conn., to the works at Branford, which is a suburb of New Haven.

The Hydraulic Press Manufacturing Company, Mount Gilead, Ohio, has opened a branch sales office at 416 Citizens' Building, Cleveland, Ohio, in charge of Charles E. Newell.

The Pressed Steel Car Company and the Western Steel Car & Foundry Company removed their Chicago sales offices from the Old Colony building to 425 Peoples Gas building on April 15.

M. D. Franey, master mechanic of the New York Central at Elkhart, Ind., has resigned to become superintendent of the Erie plant of the American Brake Shoe & Foundry Company, Mahwah, N. J.

Carleton D. Sperry, up to December, 1915, editor of the Railway Electrical Engineer, and since then with the B. F. Goodrich Company, Akron, Ohio, has entered the railway sales department of the company.

J. E. McLain, district sales manager of the Cambria Steel Company at Pittsburgh, has also been appointed manager of sales in that district for the Worth Brothers Company and the Midvale Steel Company, with offices at 1812 Oliver building.

G. I. Evans, formerly mechanical engineer, shop superintendent at Montreal, and later district master mechanic at Toronto for the Canadian Pacific, has been made general manager of the Imperial Iron & Steel Works, with headquarters at Collingwood, Ont.

E. S. Cullen, who has been associated with the Niles-Bement-Pond Company as representative for a number of years, has left the services of that company, and has established the E. S. Cullen Machinery Company, with office in the Leader-News building, Cleveland, Ohio, to deal in machine tools and locomotive cranes.

W. D. Smyth, district sales manager of the Cambria Steel Company at Cleveland, Ohio, has also been appointed manager of sales for the Cleveland territory of the Midvale Steel Company and the Worth Brothers Company. The three separate offices now maintained by these companies will be combined June 1 in new offices in the Swetland building.

Clifford J. Ellis, who has for many years been sales manager for the Cambria Steel Company at Chicago, has been appointed sales manager for the Midvale Steel Company, in charge of sales in that territory for the Midvale Steel Company, Cambria Steel Company and Worth Brothers Company in their combined relations.

The following have been elected directors of the Midvale Steel & Ordnance Company: John C. Neale, vice-president and general manager of sales of the Cambria Steel Company; E. E. Slick, vice-president and general manager of the Cambria Steel Company, and William B. Dickson, secretary and treasurer of the Midvale Steel & Ordnance Company.

Thomas Dunbar, manager of the mechanical department of the Pullman Company, Chicago, Ill., has resigned. C. W. Pflager, assistant to the manager of the mechanical department, has been appointed supervisor of the repair shops. Those officers of the construction department, who formerly



reported to Mr. Dunbar, will now report directly to Le Roy Kramer, vice-president.

Richard Brinsley Sheridan, general manager of the Brown Hoisting Machinery Company, Cleveland, Ohio, has resigned to become one of the executives of the American International Corporation, which recently purchased the Allied Machinery Company of America. He has been succeeded by A. C. Brown, assistant manager and vice-president of the Brown Hoisting Machinery Company.

The Vulcan Brake Shoe & Equipment Company was incorporated in Delaware, April 3, 1916, with an initial capital of \$1,000,000. The company will engage in the manufacture of brake shoes and grey iron castings. It will have offices in the Equitable building, 120 Broadway, New York, and works at Baltimore, Md. Its officers are: W. H. McDonough, president; Edward Barrett Smith and R. M. Brower, vice-presidents; F. W. Grant, secretary and treasurer. Robert N. Hill is engineer of tests, and H. K. Schoenheiter, superintendent of the works.

W. H. McDonough has been elected president of the Vulcan Brake Shoe & Equipment Company. Mr. McDonough was born in New York City, and was educated



W. H. McDonough

at the College of the City of New York. He is a lawyer by profession, but has been in active commercial work for some years. Until recently he was associated with the American Brake Shoe & Foundry Company, and was an officer in several corporations controlled by interests connected with that company.



E. B. Smith

and until his resignation on March 31 had been with the American Brake Shoe & Foundry Company and its predecessors, the Ramapo Foundry Company and the Ramapo Iron Works, for twenty years. When he left to become associated with the Vulcan Brake Shoe & Equipment Company he was in the sales department, specializing in the sale of brake shoes to electric railways and for the export trade.

Edward Barrett Smith, who has been elected vice-president of the Vulcan Brake Shoe & Equipment Company, was born in Riverton, N. J., and was associated with the American Brake Shoe & Foundry Company for eight years. For a number of years he was in the motive power department of the Central of New Jersey. During his first two years with the American Brake Shoe & Foundry

Company he was engaged in special work in the engineering and testing departments, and at the time of his resignation on March 31 was connected with the sales department, specializing in the sale of brake shoes to steam railroads.



R. M. Brower

F. W. Grant, who has been elected secretary and treasurer of the Vulcan Brake Shoe & Equipment Company, was born at East Windsor Hill, Conn. He was with the American Brake Shoe & Foundry Company for nine years. Prior thereto he was connected with the Pope Manufacturing Company for eight years.



F. W. Grant

He entered the services of the American Brake Shoe & Foundry Company in March, 1907, and served successively as chief clerk of the Mahwah (N. J.) plant, chief clerk at the Chicago Heights (Ill.) plant, assistant comptroller in charge of the cost department, and assistant to the vice-president in charge of sales and accounting.

Robert N. Hill, who has been elected engineer of tests of the Vulcan Brake Shoe & Equipment Company, was born in Ontario, Can. He graduated from Cooper Union, New York City, with the degree of electrical engineer, afterwards taking a post-graduate course in mechanical engineering. He was for several years in the engineering department of the Interborough Rapid Transit of New York City, and was five years in the testing and engineering department of the American Brake Shoe & Foundry Company.

H. K. Schoenheiter, who becomes superintendent of the works of the Vulcan Brake Shoe & Equipment Company, was born in St. Paul, Minn. He learned the trade of foundryman and machinist with Henry H. Ormes & Sons, of Minneapolis, with which company he was connected for 15 years, seven years of which time he was superintendent of the works. The business of this firm was later purchased by the American Brake Shoe & Foundry Company, and became known as the Twin City plant. He remained there in charge as superintendent for two years, and five years ago was transferred to the company's largest plant at Mahwah, N. J., where he remained until he severed his connection with the organization.

The Acme Supply Company announces the appointment of Franklin M. Nicholl as sales representative, with headquarters at the general sales office, Steger building, Chicago, Ill. Mr. Nicholl has been for the last seven years eastern and Canadian sales representative of the Dayton Manufac-

turing Company. Previous to that he was for five years sales representative of the O. M. Edwards Company, and for a short period was also salesman for the Curtis Truck Company.

At the annual meeting of the American Tool Works Company, held at Cincinnati, March 30, the following officers were elected: J. B. Doan, president, succeeding the late Franklin Alter; Robert S. Alter, vice-president and foreign manager; Henry Luers, secretary and treasurer. The directors are as follows: J. B. Doan, Robert S. Alter, L. E. Voorheis, Clifford Wright and Walter Hofer.

Leigh Beekman Morris, for the past four years New York district sales manager for the Cambria Steel Company, was on April 1 made manager of sales in the New York territory for the Cambria Steel Company, the Midvale Steel Company and Worth Brothers Company. It is expected that the offices of the three companies will be consolidated in New York City, possibly in the City Investing building, 165 Broadway, where the Cambria offices are now located. Mr. Morris has been connected with the sales organization of Cambria Steel Company for about 23 years.

B. A. Clements, western railroad representative of Worth Brothers Company at Chicago, has left that position, and has been elected vice-president of the Rome Merchant Iron Mills. Mr. Clements was born at Indianapolis, October 3, 1877, and after graduation from the public schools of Centralia, Ill., entered the service of the Illinois Central as messenger boy. From 1891 he served successfully as clerk and stenographer to the roadmaster and superintendent of the Chicago and St. Louis divisions until July, 1898, when he became secretary to the general passenger agent of the Michigan Central at Chicago. In 1899 he returned to the Illinois Central as secretary to the general superintendent of transportation, and from 1902 to 1904 was chief clerk to the general manager. From 1906 to 1909 he was chief clerk to the vice-president in charge of operation, when he was appointed general agent, operating department, reporting to the president. In 1910 Mr. Clements left the Illinois Central to accept the position of western railroad representative of Worth Bros. Company, with headquarters at Chicago. As vice-president of the Rome Merchant Iron Mills, he will have headquarters at 30 Church street, New York.

The Universal Arch Company has been incorporated for the manufacture and sale of locomotive arch fire brick and other railway equipment. The company has established its general offices in the McCormick Building, Chicago, directly in charge of William Smith, president, formerly master mechanic of the New York Central, J. B. Kilpatrick, vice-president, formerly district mechanical superintendent of the Chicago, Rock Island & Pacific, and John H. Cavender, vice-president and treasurer. The company has placed contracts with leading fire brick manufacturers. The types of locomotive arch fire brick which the new company has placed upon the market have been passed upon and accepted by the Western Railroad Association



B. A. Clements

## CATALOGUES

**PULVERIZED FUEL.**—The United Combustion Company, 30 Church street, New York, in its first bulletin issued under date of March 1 describes the company's pulverized fuel feeder for stationary service.

**MACHINE TOOLS.**—Bulletin No. 140 recently issued by the Lodge & Shipley Machine Tool Company, Cincinnati, Ohio, is a manual for the operator's guidance in using Lodge & Shipley engine lathes and attachments. It gives brief descriptions of the different parts of the lathe, instructions for operating, suggestions for handling work, grinding tools, etc.

**PUMPS.**—The A. S. Cameron Steam Pump Works, New York, has recently issued bulletins Nos. 154 and 110. Catalogue 154 is devoted to Cameron centrifugal pumps. Sectional views are used to illustrate both the single and double suction open impeller types, and the booklet gives tables of capacities, speeds and horse powers. Catalogue 110 covers the Cameron line of duplex pumps, including both piston and plunger types, with single and compound steam cylinders for general service, boiler feeding, tank service, water works, hydraulic elevators, automatic pumps and receivers, brewery, quarry and mining work. The catalogue is well illustrated and also contains tables of sizes and capacities.

**CORROSION RESISTANCE OF COPPER STEEL.**—The American Sheet & Tin Plate Company, Pittsburgh, Pa., has issued a 22-page booklet entitled, "Research on the Corrosion Resistance of Copper Steel," by D. M. Buck, metallurgical engineer, American Sheet & Tin Plate Company, Pittsburgh, and J. O. Handy, director of laboratories of the Pittsburgh Testing Laboratory, Pittsburgh, describing the results secured from elaborate tests on full size sheets of copper-steel alloy. These tests show that steel or iron containing copper shows greatly increased corrosion resistance when exposed to atmospheric conditions, the most effective amount of copper for this purpose being approximately 0.25 per cent. This book is valuable to any one interested in this subject.

**ALLOYS.**—The Titanium Alloy Manufacturing Company, Niagara Falls, N. Y., has recently issued, through its bronze department, a booklet bearing the title: Titanium Aluminum and other standard bronze castings. This booklet describes over 30 alloys made by the company for various uses. In the case of each alloy there are given the approximate composition, the service for which the bronze is best adapted and the physical properties, as well as etchings showing each alloy magnified 20 and 200 diameters. A number of pages in the book explain how the various tests were made and contain tables showing: The electro-chemical series of the elements; the resistance and relative conductivity of various metals and alloys; physical constants of the more common metallic elements, etc.

**FIRE EXTINGUISHERS.**—The railroad number of the Firefly issued by the Pyrene Manufacturing Company, New York, under date of February, 1916, shows in a striking way the necessity for fire extinguishers in railway cars, stations, warehouses and similar places. The articles are illustrated with pictures showing fires in and the resulting destruction of railway property, the point being made that in nearly every case the fire could easily have been extinguished before it had become too big had fire extinguishers been available. It is noted, moreover, that in each of these cases the value of the property destroyed was many times the cost of a complete installation of extinguishers. The advantages of Pyrene extinguishers are given in detail and mention is made of the installations in railway service and of instances in which the Pyrene apparatus was put to good use by being at hand when the fire started.

# Railway Mechanical Engineer

Volume 90

June, 1916

No. 6

## What is Heat Treated Steel?

On page 111 of the March issue of the *Railway Mechanical Engineer* we announced that a prize of \$35 would be awarded for the best article, and a prize of \$25 for the next best article submitted on heat treated steel. The competition closed on May 1, and the first prize has been awarded to Lawford H. Fry. Mr. Fry is with the Standard Steel Works Company and is well qualified to speak on this subject. His article will appear in the July number, and will answer many of the questions arising in the minds of railroad men relative to the heat treating process and to the handling of heat treated material in the repair shop. The second prize has been awarded to George Hutton and will appear in an early issue. Several other articles were received which will be published in whole or in part from time to time and which contain a number of valuable suggestions for the blacksmith foreman who may be called upon to handle a heat treating plant.

## The Cleaning of Locomotives

We have never been able to see the logic in the argument that it is economical to let locomotives go without cleaning. In the first place, clean locomotives as well as clean cars help materially in advertising the road in the right way; then there is the standpoint of safety. There is no question that a locomotive can be much more thoroughly inspected if it is cleaned than if it is not, and the damage done by the breaking of a single part can very easily cause trouble that will cost in repairs enough to clean a good many locomotives a good many times. Only recently we had called to our attention a crack in a strap which, if the engine had been allowed to go without cleaning, as is the case on many roads, could not have failed to have resulted in a bad accident. In this case the engine was cleaned and it was due to this fact alone that the inspector was able to find the crack which, at the point where it was visible, was extremely small. It is surprising that the oil-and-water method of cleaning which has been so successful on the Lackawanna has not had a more extended application on other roads. The process of cleaning by this method is extremely simple, the cost is small and the appearance of the engines on that road is a plain indication of the results which it gives.

## Locomotive Repair Facilities and Costs

It was recently stated by a mechanical department officer of a large road that while his road spent relatively a very large amount on locomotive repairs, the power was still not in as good condition as on some roads where the expenditure per locomotive-mile was lower. This officer did not understand why this should be so but he admitted that the shop and enginehouse facilities of his road were not as good as they ought to be. The saving that can be effected in the cost of locomotive repairs by adequate and up-to-date shop and enginehouse equipment is ample

justification for the expenditure for such improvements. Consider, for example, two roads, one with a locomotive cost of 8 cents per locomotive-mile and the other one a cost of 15 cents. There must be some good reason why the road with the lower cost can obtain such a figure, it being assumed, of course, that the power is kept in good condition by an expenditure at this rate. It should be apparent without any extended argument that the difference between 8 cents and 15 cents per locomotive-mile when applied to the considerable total to which locomotive mileage climbs during a year of ordinary business, will constitute a percentage of the operating expenses which, if it appears in the form of a reduction, will prove ample justification for the money which has been expended in shop and terminal improvements.

## Convention Papers and Discussion

It seems as if some improvement could be made as regards the amount of time taken up at conventions by the reading of papers. If the papers were sent out a sufficient length of time before the time of meeting there is no reason why every member should not familiarize himself with their contents so that all that should be necessary at the convention by the author or the committee chairmen is a few remarks emphasizing the more important parts of the paper. This would lengthen the time for discussion, and if the papers were properly gone into beforehand instead of being glanced through as the chairmen read them, the members would be much more likely to find in them points which they would feel competent to discuss. A good many of our mechanical conventions are given over to a large extent, and we feel to too great an extent, to the reading of papers which have been already printed, and, unless there has been some unusual delay, have been in the hands of the members for some time before they arrive at the convention. Under such circumstances it is the fault of the members themselves if they are not familiar with the contents of the papers and it does not seem right that the amount of time that is now commonly given to the reading of papers should be taken from the time of the convention when it could be used to much better advantage either in a discussion by the members or in some other way.

## Dealing With Government Inspectors

Some railway mechanical men are severe in their criticism of the methods pursued by the boiler and machinery inspectors of the Interstate Commerce Commission. Doubtless, some of this criticism is justified but at the same time we believe that some of the railway officers are too prone to look for faults in the inspectors. Whatever the attitude taken by the individual members of the inspection staff, it is well known that those in charge of the inspection work have no wish other than to deal fairly with the railways in every way, meeting them half way or more than half way wherever it is possible. It is easy to understand how a foreman or master mechanic can have his

work considerably upset and his temper severely strained by the action of an inspector, but on the other hand we have known cases where the inspectors were antagonized from the first and would have been justified in taking even more severe measures than they ultimately did take. We do not believe that any inspector unless he be of an unfair mind, wishes to hold a locomotive out of service if it can be avoided in any way possible without violating the law; nor do we believe that the chief inspector desires to retain on his staff any man who is not disposed to give the railways a fair show. But a good deal of the unfairness of mind and attitude is on the side of the railway men. It requires a little diplomacy and a good deal of common courtesy on both sides but whether or not the railway men originally disliked the idea of having the inspectors around they may as well make up their minds now that inspection has come to stay and that it will be much easier to make matters run along smoothly if the inspectors are on their side, at least to the extent of knowing that they will do the right thing, than it would be to have them against them.

#### Welding Tubes in the Back Tube Sheet

When the practice of welding tubes in the back tube sheet was introduced about five years ago it promised much in simplifying boiler maintenance in the roundhouse. Under some conditions the practice has been very successful not only in increasing the life of the tubes but in reducing the cost of maintenance. The discussion of the report on electric welding at the convention of the Master Boiler Makers' Association brought out very clearly, however, that while electric welding of tubes has been successful in good water districts, it has been very much less successful in bad water districts. In all cases where bad water is used the tubes eventually leak in spite of the welds, and when leaking begins to take place, working the leaky tubes soon loosens the welds on those adjacent until conditions are no better than they would have been if the welds had not been made.

It is probably possible to make welds in the back tube sheet that will hold the tubes even under the most severe conditions but this would result in undue damage to the sheet when removing the tubes. The practice followed by one of the southern roads is worthy of attention in this connection. The tubes of engines running in bad water districts are not welded when applied, but are set in the usual manner. After the engine has been in service and when trouble from leaking begins they are re-welded in. They will then run for sometime longer before requiring constant attention. The result is a considerable saving in the amount of roundhouse work required to keep the engines in service, although the life of the tubes themselves is not increased.

#### Air Brake Association Convention

Those attending the convention of the Air Brake Association, held in Atlanta, Ga., last month, must have come away with two thoughts uppermost in their minds. The first relates to the problem of a proper foundation brake gear to be used on the improved heavy passenger equipment in service today; and the second, the necessity of giving much more attention to the proper maintenance of the air brake equipment, especially on freight cars, than has been the custom in the past. From the papers and discussion it was shown that considerable difficulty is being experienced in handling long passenger trains without injury to the equipment, let alone without inconvenience to the passengers. One prominent air brake inspector was heard to remark that break-in-tuos in some of the best passenger trains on his road were becoming altogether too common. This trouble is caused by unequal brake cylinder piston travel on the different cars in the train due to inefficient foundation gear. To obviate

such conditions it was believed that the clasp type of brake was a necessity.

The need of better air brake maintenance was made plain by the investigations mentioned in Mr. Purcell's paper on "Maintenance of Freight Brakes." Train line leakage not only means poor air brake performance, but in many cases limits the length of trains. Brake cylinder leakage is another source of a great deal of annoyance and considerable trouble; it causes unequal braking of the cars resulting in break-in-tuos. Both the repairs to the air equipment and the train line leakage can be controlled by proper supervision and education of the air brake mechanics. This has been proved by several roads which control their train line leakage to below five pounds per minute.

The paper on "Air Brake Apprentices" was of special interest and will be found of considerable value, for it is here that the railroads are deficient. The work of the air brake repairman affects all the departments of the railroad. It is the results of his work that carry the trains over the lines with despatch and without damage. He should be carefully educated and instructed in his work. Air brake work is not for any Tom, Dick and Harry that happens along; it is a real man's job and requires experience and care.

#### Storekeepers' Association Convention

The recent convention of the Railway Storekeepers' Association at Detroit was well attended and the members in presenting their remarks seemed to know what they had to say and went about saying it without any undue delay. Undoubtedly the proceedings were materially assisted by President Stuart, who insisted on everything being done on time. There is room for improvement at all the conventions in the matter of adhering to the schedule and all could well take a leaf from the book of the Storekeepers' Association in this regard.

In his presidential address Mr. Stuart laid special stress on several important points, among which may be mentioned that of storekeepers familiarizing themselves more with the conditions and requirements affecting material in the various departments. There is a great deal of time lost and material delayed because of differences of opinion between the store department and whatever other department may be concerned. If the storekeeper will get in touch with what is going on in the various departments and learn so far as it is possible how material is used and how much of it is used at various times, he will make himself a much better storekeeper and a much better man for his railway. Undoubtedly, as Mr. Stuart suggests, this adds to the breadth and responsibilities of the storekeeper's position, but it also tends to make of him a better all round railroad man, and what the railroads of this country need are railroad men and not merely department men.

Several papers were presented at this meeting on the handling of company material and the subject was considered of such importance that it was decided to have a committee to prepare a report for presentation at the next convention. The most important point brought out in all of these papers was in connection with the prompt release of cars which are loaded with company material in order to get them back into revenue service as quickly as possible. This is something that all storekeepers and in fact all railway officers should keep constantly in mind. Cars constitute a large part of the means of bringing in the company's earnings and every one that is kept in non-revenue service when it might be in revenue service is reducing the company's possible earnings. There is too much tendency on the part of the stores and mechanical department officers, at small points in particular, to consider a car more or less as of no great importance and consequently material is frequently left in the cars when it should be unloaded and the car released. Another

point that is worthy of attention in connection with the conservation of cars is the consolidation in one car of as many shipments as possible for outside points. It is a very common occurrence to find a number of cars moving in the same direction, and all with only partial loads in them. It is quite possible in many cases to make one car do the work of two or three.

#### Railway Fuel Association Convention

The importance of the International Railway Fuel Association to the railroads of this country and to railway men who are directly interested in the handling of fuel is increasing year by year. Of the subjects considered at the eighth annual convention, held in Chicago last month, that of powdered coal will be found of greatest interest to the mechanical department officers. The paper, which outlined the progress in the use of this grade of coal, was supplemented by a most interesting discussion. A large number of the members of the association who have ridden the Chicago & North Western locomotive, which was equipped during the past year with powdered coal burning apparatus, could not speak too highly of the performance of this engine in service. In addition to this the remarks of C. W. Corning, of the North Western, who has been with the locomotive constantly since the powdered fuel apparatus was applied, gave considerable additional information as to the merits of powdered coal in locomotive service.

Taking the discussion of the fuel problem as a whole, a thought of pre-eminent importance and one which appeared in almost every subject discussed, was that of the necessity of proper co-operation by the transportation and general operating officers in order to make a successful effort to save fuel. There is hardly a man in a railroad's employ who cannot contribute his mite toward fuel economy. While the engine crew are the ones who finally consume the fuel, it is necessary that they be assisted by having properly maintained equipment to operate, by being delayed on the road as little as possible, and by having the road conditions suitable for a good fuel performance. They should be properly trained and given every opportunity to know how they may best get the most out of a ton of coal. The importance of carefully selecting the proper grade of men for firemen was specially emphasized.

In the purchase and inspection of coal there is much that can be done to provide fuel that will prove the most economical to use. Chemical analysis and the price alone are not sufficient to determine what coal should be used. Careful service tests, supplemented by these two factors, should be the criterion on which to base the purchase of coal. The fuel bill for American railroads takes seven cents out of every dollar earned by the railroad companies. It is, therefore, an important factor, and is deserving of far greater attention than is at present given to it by some roads. The results obtained on the Chicago Great Western, as mentioned by S. M. Felton, president of that road, in his address before the association, show what can be done by giving this problem proper attention.

#### Painting of Steel Freight Cars

The condition of many of the steel freight cars in general service is so bad, due to the lack of paint, that we feel that it would be well to call the attention of mechanical department men to some of the statements that have been made by experienced car men as the result of careful experiments with cars painted in various ways. There has been a great deal of discussion as to whether or not it pays to keep steel coal and ore cars well painted but, as pointed out by M. K. Barnum, superintendent of motive power of the Baltimore & Ohio, in his article on the life and maintenance of steel cars, published

in the *Railway Mechanical Engineer* for March, 1916, many of the higher officers who are responsible for the entire cost of operation seem to have come to the conclusion that it does not pay to paint them except when they receive new sheets or the letters and numbers need to be brightened up so that their ownership and identity can be distinguished. It would almost seem that any road would have sufficient pride in the appearance of its equipment to avoid the unsightly splashes that are daubed on many steel hopper and gondola cars in order to make a background in the general field of rust on which the letters can be placed.

It is not out of place to quote again from the report of the committee of the Master Car Builders' Association on this subject, presented at the 1908 convention, and to urge railway officers to give this matter of painting more energetic attention: "We cannot be too emphatic as to the necessity of taking the proper care of the exterior, and regret that we are not able to give the interior the same care. The painting of the inside of steel cars has been thought by some to be beneficial, but your committee can see no lasting results in this, and do not recommend it, but are of the opinion that coating the interior of the cars about once every six months with black oil would act as a preservative." As to the economy of painting steel cars Mr. Barnum says definitely in his conclusions that it will pay to keep steel cars well painted on account of preserving their strength, improving their appearance and extending their life, and a glance at some of the illustrations in his article should convince the most skeptical of the advisability of the proper protection of such cars.

Again in a comprehensive paper on the life of a steel freight car, read before the Pittsburgh Railway Club, and abstracted in the *Railway Mechanical Engineer* for January, 1916, S. Lynn, master car builder of the Pittsburgh & Lake Erie, one of the pioneer roads in the use of the steel car, says that if a steel car is given reasonable treatment and repairs are made when they are needed and *if the car is repainted when the steel becomes exposed to the weather*, the renewing of some of the parts will not become necessary for a longer period than is now the case. With what Mr. Barnum brings out in his article this testimony from such a road as the Pittsburgh & Lake Erie should provide ample evidence that proper painting of steel cars is not only desirable, but is essential, if the maximum life and earning capacity is to be obtained from these cars.

#### NEW BOOKS

*Principles of Locomotive Operation and Train Control.*—By Arthur J. Wood, M.E., assistant professor in charge of railroad mechanical engineering, Pennsylvania State College. Bound in cloth. 264 pages, 6 in. by 9 in. Illustrated. Published by the McGraw-Hill Book Company, Inc., 239 West 39th street, New York.

The absence of a text book presenting the recent developments in locomotive performance and including a study of air brakes led the author to prepare this work, which is intended as an elementary treatise for use in technical schools. At the same time the engineer may review in it the theories on which are based certain problems in design and construction. The author has endeavored to present the principles, beyond which lies the field for extended study. The book takes up tractive effort, the acceleration of trains and train resistance and there is a chapter devoted to new graphical methods applied to locomotive performance as well as one on dynamometer car tests and tonnage rating. Another chapter is devoted to air brakes while considerable space is also devoted to combustion and fuel economy; the formation and action of steam; theory and practice as regards superheated steam; locomotive ratios; testing, and counterbalancing. Chapters are also given to the electrification of steam railways, and materials of construction, while an appendix contains a number of valuable tables.

## COMMUNICATIONS

### LEAKAGE OF HORIZONTAL SHEATHING

HAMILTON, Canada.

TO THE EDITOR:

Regarding the leakage of outside steel frame, horizontally sheathed box cars, referred to in an editorial in the *Railway Mechanical Engineer* for March, 1916, if the question of water passing through the tongue and groove joint, apparently by some sort of capillary action, is a vital one in this design, would not a joint similar to that shown in the sketch minimize, if not entirely overcome this action?



A. E. HEFFELFINGER,  
Chief Draftsman, National Steel Car Company, Limited.

### TOBESURA WENO ON LOCOMOTIVE INSPECTION

(With apologies to Wallace Irwin)

CHICAGO, Ill.

Dear editor:

I have now become U. S. Federal I. C. C. detector. My job are to catch slick mms. and dope eater formen who defy Safety First and members of Honorable brotherhood.

I have assume great pleasure in presenting form 5 although some time it appear to create extreme disgust to mms. who affirm it are disagreeable and impudent interference with states rights and constitutional perogative of RR. corporation.

On large railroad I have just experience peculiar situation. I detect switchlocomotive with wheel rubbing on staybolt side sheet. I immediately call out forman and demand full explanation, assuming it are entirely necessary to douse fire to prevent disagreeable explosion. Foreman summon boiler man who reply that huge mistake been made on this engine. I inquire to know and he relate



"I Dispute and Flash Scale and Caliper"

that she just complete new coal box in rear shop and on account bonehead bull by active foreman  $\frac{3}{4}$  inch sheet installed by error. So soon as one sixty-fourth worn off by encroaching driver wheel, engine are to go to shop for new sheet of proper section. I agree and call attention to sand pipe not hitting middle of track. Foreman say it are correct so I dispute and flash scale and caliper. It follow as I say and sand distribute on track one thirty-second inches from center. I order repair made soon and when foreman disavow intention to defraud, I rescind Form 5.

Yours truly,

TOBESURA WENO.

### A CORRECTION

CHICAGO, Ill.

TO THE EDITOR:

My attention has been called to a paragraph under the heading, "Supply Trade Notes," on page 272 of the *Railway Mechanical Engineer* for May, 1916.

It is there stated that the types of arch which the Universal Arch Company (formerly the National Arch Company) has placed upon the market "have been passed upon and accepted" by this association. In view of the wide circulation of your paper, I cannot allow this unauthorized

statement to pass without correction, lest our members be misled. With one exception, this association has held that the arches, so far as known to us, offered by the Universal company infringe prior patents and can only be used, if at all, under bond.

GEORGE S. PAYSON,  
General Counsel, Western Railroad Association.

### APPRENTICESHIP IN THE DRAWING ROOM

OMAHA, Neb.

TO THE EDITOR:

It seems to be the practice on our road to let a boy start as a sort of a messenger for the drawing room and filing clerk as well, and then work into the drafting room. In this way he gets to see the different phases of the drafting business and may learn to read blue prints and incidentally to do some drafting before he takes up the work seriously.

Occasionally some little job will come up which does not require much experience, and it is given to the young hand to do. Gradually he is intrusted with more complicated work, and as soon as there is an opening on the table he is generally able to do fair work.

The greatest aid which I received while working up to my present position was the interest which was shown by the other draftsmen, who, when they could, explained drawings and the methods used by the draftsmen.

Another thing which always helped was that whenever any package or message was to go to the shops *rush*, we boys were the ones to take it. In this way, by keeping our eyes open, we could see how things were done and what could be done with iron, steel, etc. The thought that if we did keep our eyes open and learn things we would have a chance to become draftsmen was a spur and inspiration.

WILL C. MOONEY, JR.,  
Draftsman, Union Pacific.

### THE MECHANICAL DEPARTMENT CLERK

RAILROADVILLE, U. S. A.

TO THE EDITOR:

I heartily agree with the writer of the letter "The Mechanical Department Clerk," in your April number, having been a mechanical department clerk for 17 years and still being on the "blind alley job."

We are requested not to join any labor organization and personally, I feel that the request should be recognized by any clerk in this department, due to the fact that we come in contact with and have the handling of considerable important correspondence and details.

The highest point which a strictly mechanical department clerk can ever reach would be that of chief clerk to the superintendent of motive power. This would not happen to one in a thousand of us. I have clerks of my acquaintance who have never been advanced in position or salary, other than general increases which were given by the company of their own initiative. This is not so much the fault of the clerks as of opportunities which present themselves. Even the stores department would be a better place for a young man to enter as clerk. I know of storekeepers and superintendents of stores who have advanced from clerkships. Speaking of transportation department, I know of cases where men started in as clerks and advanced to the position of trainmaster and division superintendent.

I feel, along with A. C. Clerk, that the clerks in the mechanical department are not given proper consideration. We have full office details to look after and keep straight and this is no easy matter with the Interstate Commerce Commission and the various state commission rulings of the present day. Added to this, the factory inspection laws and requirements which affect some of our states, and the life of a clerk in the mechanical department of any railroad is anything but a bed of roses.

ONE OF THEM.

# FUEL ASSOCIATION CONVENTION

Papers on Powdered Fuel, Locomotive Maintenance  
and Fuel Economy, Front Ends, Coal Analysis



*Banquet of the International Railway Fuel Association*

**T**HE eighth annual convention of the International Railway Fuel Association was held in the Hotel Sherman, Chicago, May 15 to 18, D. C. Buell, Union Pacific, presiding. The convention was opened with prayer by Rev. Joseph A. Milburn.

## PRESIDENT'S ADDRESS

Mr. Buell said in part: A survey of activities along fuel lines during the past year discloses several noticeable achievements, among which are the development of fuel economy devices, the excellent results obtained by a number of roads in the economical use of fuel and the completion and publication of the Report of the Chicago Association of Commerce Committee on Smoke Abatement and Electrification of Railway Terminals in which it was shown that the steam locomotive was a minor offender among the list of smoke producers. Among the important things yet to be accomplished in order to further improve the fuel service of our railroads may be mentioned:

First: The perfection and adoption of devices or schemes whereby an accurate check can be made on the amount of coal delivered to a locomotive and used during a trip.

Second: The working out of a practical plan for simple, accurate daily reports showing the economy or lack of economy with which fuel is being used, so that prompt action can be taken by those responsible for its use.

Third: The development and adoption of C O<sub>2</sub> recorders for use on locomotives.

Fourth: A reduction in the amount of fuel consumed by locomotives while at terminals. The possibility of running locomotives over more than one division may be worthy of careful reconsideration.

Fifth: A more careful review of the use of fuel for other than locomotive purposes. Approximately one-twelfth of a railroad's fuel bill is for coal used in this way.

Sixth: The education of new firemen before they are placed in regular service.

In connection with the latter item it is suggested that a school for new firemen be established at some central point on each system, where applicants can be instructed concerning the principles underlying practical locomotive firing.

There are two fundamental principles in connection with the present method of fuel handling that I desire to call particular attention to today. The first is the necessity for a more complete and thorough understanding of the importance of fuel matters by operating officials. The responsibility for

fuel economy has too long been considered purely a mechanical department matter.

The second is the necessity for a more careful consideration being given to the dollar-and-cents value of things. It is my firm belief that railroad men must educate themselves as to the cost of material, supplies and operation more fully than in the past in order that they may more properly analyze conditions and thus be better fitted to apply their best efforts to those matters wherein the largest and most practical savings can be effected.

## ADDRESS BY MR. FELTON

S. M. Felton, president, Chicago Great Western, talked on the "Railroad Fuel Problem, Past and Present." He described the system followed by the Pennsylvania Railroad on its Western lines during the Seventies. At that time that road charged each engine crew with the coal placed on the tender and a performance sheet was made up each month. In referring to the present practice he described the system followed on the Chicago Great Western, saying, in part:

In 1909 the line was equipped with the old-fashioned chutes, coal being unloaded by hand from gondolas and box cars at a cost of about 10c. per ton. In order to carry out the program decided upon, the old stations, which were pretty well along in years, were torn down and replaced by modern mechanical stations of the conveyor or balanced bucket type. Instead of having a number of small pockets the stations were designed with one large bin, which was mounted on or suspended from specially designed scales, the scale beam being placed on the track level where the inspector in charge of the coaling station could weigh the coal conveniently. By means of a registering device, duplicate tickets are printed showing the actual amount of coal taken at any time from the bin; one ticket is handed to the engineer and the other retained by the man in charge of the coaling station. The company provides self-clearing cars designed to handle the coal in the most economical manner, and keeps these cars in company coal trade. This makes it possible to handle coal at these stations at a cost ranging from 2 to 3 cents per ton, depending upon the tonnage handled; the cost includes maintenance.

When the contracts were made the actual analyses of the coal and the Btu's were embodied therein, and, in order to see that they were observed, samples of the coal as received were taken every two weeks and analyzed; in addition, a coal inspector was placed at the mine.

It was determined that it would be more economical to

use coal from one mine for each division, rather than have different mines supply the same division. After the contract is made, the superintendent has entire charge of its execution; the inspector at the mine reports directly to him; he has charge of the coaling stations, is responsible for the weighing, and is furnished with the analyses of the coal. The best possible supervision and most economical results are obtained, because of this concentration of authority.

The actual weight of coal in the tender of a locomotive is reported to the chief dispatcher before the train starts, coal taken at intermediate coaling stations on the run is reported by wire, and upon arrival at terminal the coal on the tender is leveled off by a man assigned to that duty; the amount determined by means of measuring strips on the inside of the tender is likewise reported to the chief dispatcher, who is then able to figure the exact amount of coal consumed on the run. The chief dispatcher gets the trainload when the train leaves terminal and the conductor reports to him any changes en route, so he is able to determine the gross ton miles handled by the engine during the trip. As a result of careful investigation, allowances are determined for the different engines and different classes of service, and if the engine has consumed more than the assigned amount of fuel the engineer is immediately interviewed in order to determine the cause of the trouble; it may be the fault of the engine crew, it may be the fault of the locomotive, but whatever the cause it is at once investigated and a remedy applied, so that a check is made daily instead of waiting, as used to be the custom, until the end of the month. The knowledge the engine crews have that the coal is actually weighed is worth many times what it costs to do the weighing.

On the eastern division, in passenger service, in 1915, compared with 1911, when the system was first put in force, the train mileage increased 1.5 per cent, being very nearly the same; the tons of coal consumed decreased 28 per cent, the cost decreased \$25,851, or 28 per cent, and the pounds of coal consumed per passenger car mile decreased 31.7 per cent.

In freight service between 1911 and 1915, the trainload increased from 505 to 790 tons, or 56 per cent; the gross ton miles increased but 1 per cent, the tons of coal consumed decreased 27 per cent, the cost decreased \$94,671, or 27 per cent; the tons of coal consumed per 100 gross tons moved one mile decreased 28 per cent, the price per ton having remained practically the same.

It was customary in days gone by to provide switching power in many cases from wornout road engines. But more recently a series of tests has demonstrated that the ordinary road engine does not make a desirable switcher and is anything but economical in fuel consumption, so engines specially designed for switching service, superheated and with brick arches and all the latest devices for the prevention of smoke have been adopted.

The use of powdered coal, which you are now so carefully studying, will undoubtedly give the most satisfactory results that can be looked for outside of the use of oil, and I look forward to the work you are doing in that direction with

the greatest possible interest. You certainly should, and no doubt will, be encouraged in this work to the greatest possible extent by your executive officers.

In conclusion, the lesson to be drawn from this talk is:

First—Check-weigh and analyze coal at frequent intervals, as received from the mines.

Second—Weigh all coal to individual locomotives; keep records of the coal consumed, not only by locomotives, but by engine crews as well.

Third—Check the individual performance of locomotives and crews against the actual gross tons handled per freight train mile; per car mile in the case of passenger trains, and per hour worked by yard engines.

Fourth—The responsibility for the coal from the time it is mined to its final consumption should be fixed upon the division superintendent, so there may be no conflict of authority.

Fifth—In the purchase of new locomotives, specify superheaters and brick arches of approved form; also equip old engines where age and capacity justify the expenditure.



D. C. Buell, President,  
International Railway Fuel Assn.

## EFFICIENCY OF RAILROAD OPERATION

BY SAMUEL O. DUNN  
Editor of the Railway Age Gazette

It is the irony of fate that the managements of the railways of the United States should have been subjected to criticism for alleged inefficiency at the very time when they have been giving the most splendid demonstration of efficiency in the history of transportation. It is not exaggerating, but speaking the words of truth and soberness, to say that the courage and efficiency displayed by their managements, in meeting and triumphing over the unfavorable conditions with which they have had to deal during the last ten years, have never been exceeded in industrial history.

Many abuses have existed and many offenses have been committed on our railways; but we should begin to recognize and emphasize the fact that the shortcomings of their managements have been far more than compensated for by their constructive achievements. Consider briefly the circumstances in which their officers have had to do their work during the last ten years. In August, 1906, the Hepburn act went into effect, giving the Interstate Commerce Commission increased authority over rate-making and accounting and over some features of operation. Maximum freight rate laws, 2-cent fare laws, acts prescribing the number of hours the employees might be kept at work, the number of them there should be in train crews, etc., were poured forth in all parts of the country. There was a perfect cloudburst of regulatory laws and orders. There was one great and successful movement after another by railway employees for increases in their wages. There were demands for new and improved facilities—for steel cars, the elimination of grade crossings, the installation of block signals, and so on—which caused heavy additions to the investment demanding that a return be paid on it.

Let us see what was the effect of certain of the more important changes which occurred during this period on earnings and expenses. The average freight rate per ton



per mile was reduced from 7.48 mills in 1906 to 7.33 mills in 1914, and the average passenger rate from 2.003 cents to 1.982. That cost the railways \$50,800,000 a year; and it includes nothing for the reduction of express and mail rates.

The taxes the roads had to pay were increased from 3.2 per cent to 4.6 per cent of their total earnings. This increase in the rate of taxation made the total taxes paid in the year 1914, \$42,650,000 greater than they would have been if this increase in the rate of taxation had not occurred. The average compensation of a railway employee in 1914 was \$218 greater than in 1906, which makes a total of \$369,600,000 more than it would have been on the basis of the average wages paid in 1906. These reductions in rates and increases in taxes and wages between 1906 and 1914 made a total increase in the annual burden, direct and indirect, that the managements had to carry of \$462,902,000. In 1906 it took 69 cents out of every dollar earned to pay operating expenses and taxes. In 1914 it took 77 cents out of every dollar earned to pay operating expenses and taxes. If none of these changes in rates, taxes and wages had occurred, and the roads had been managed and operated otherwise just as they were, their net operating income in 1914 would have been \$1,168,900,000 instead of only \$706,000,000, and it would have required only 61 cents out of each dollar earned to pay expenses and taxes, as compared with 69 cents, the outlay per dollar of earnings for operating expenses and taxes in 1906, and 77 cents, the actual outlay for these purposes in 1914.

These data are a striking vindication of the efficiency of the management of our railways. They show clearly that the roads were constantly being operated more and more economically, but that much faster than they could save money it was being taken from them. They also show that it was the rate-regulating authorities, the tax gatherers and the employees who were taking it. Let us hope that the time will come when those who serve the railways, and through them the public, so well as do the International Railway Fuel Association and its members, will have their work better appreciated by the public, and will not see the results of it constantly swept away chiefly to benefit classes of persons connected with the railways who constantly strive to prevent increases in the efficiency of operation or other classes of persons who are not connected with the roads at all.

Various other steam railways, among which may be mentioned the Atchison, Topeka & Santa Fe, Grand Trunk, Southern Pacific, Kansas City Southern, Chicago Junction,

the Delaware & Hudson has just put into freight service a new powdered fuel burning Consolidation locomotive, probably the largest of this type in the world. The Delaware & Hudson is also installing a complete fuel drying, pulverizing, storage and disbursing plant, and is equipping the stationary boilers at Olyphant, Pa., for burning the waste tailings from anthracite culm banks. The Missouri, Kansas & Texas is installing a complete pulverized fuel preparing plant at Parsons, Kas., and applying equipment or burning pulverized coal and lignite in its stationary boilers and locomotives.

The usual methods for burning pulverized fuel necessitate the use of steam, air or mechanical contrivances for projecting the fuel, or a mixture of fuel and air, into the furnace. When applied to steam generators this process has resulted in failure due to the severe effect of concentrated heat on the firebrick and firebox. The more recent process, as applied to the Chicago & North Western and other steam locomotives, provides for a combustible mixture of fuel and air being automatically induced or drawn into the firebox by means of the front end draft, and its perfect combustion in suspension without any concentration of heat, due to the fact that the combustion flamework and the products of combustion are at all times being drawn toward an opening and thereby avoid any impinging action. Furthermore, this process is divided into three stages, *i. e.*, conveying and comingling of fuel and air, gasifying of combustible mixture, and perfecting of the combustion in the final high temperature heat zone, all of which insures completion of the combustion process.

From observations taken with fuels of different kinds and degrees of moisture and fineness, in every case the smokebox gas analyses will average between 13 and 14 per cent of CO<sub>2</sub> when coal is fired at the relatively low rate of about 3,000 lbs. per hour, and is increased to 15 and 16 per cent of CO<sub>2</sub> as the rate of combustion increases, so that there is no falling off in the efficiency, as obtains when coarse coal is fired on grates. At the same time the smokebox temperatures are maintained between 425 deg. and 500 deg. F. Summing up the results that are being obtained from the use of powdered coal in locomotive service, they may be stated as:

First—Smokeless, sparkless and cinderless operation.

Second—Maintenance of maximum boiler pressure within a uniform average variation of three pounds without popping.

Third—An increase of from 7½ to 15 per cent in boiler efficiency as compared with burning lump coal on grates.

Contents	Illinois Bituminous Unwashed Screenings		Kentucky Bituminous Screenings	North Dakota Lignite	Pennsylvania Bituminous Run of Mine					Pennsylvania Anthracite Waste Tailings from Culm Banks	Pennsylvania Bituminous Run of Mine
	From 3.18 to 15.36	1.9 to 2.8	1.8	1.8	0.72	0.95	0.51	0.88	0.67	Average 0.50	Average 0.50
Moisture (%)	Average 34.0	36.0	47.25	62.51	59.80	59.17	63.05	65.16	Average 8.30	Average 33.0	
Volatile (%)	Average 47.0	54.0	40.91	8.94	9.35	9.59	10.40	13.21	Average 72.09	Average 57.50	
Fixed carbon (%)	Average 10.0	8.0	9.32	28.75	30.85	31.25	25.67	21.63	Average (12 to 22), 16.50	Average 9.0	
Ash (%)	Average 1.70	0.79	0.72	2.49	2.30	2.21	1.64	1.51	Average (0.66 to 1.97), 1.00	Average 2.00	
Sulphur (%)	From 10.720 to 12.400	13.964	10.960	14.096	13.773	13.804	13.912	13.671	Average 12,000	Average 13,750	
B. T. U.											
Fineness:											
Through 100 mesh. (%)	From 90.7 to 99.69	93.0	98.0		From 88.0 to 96.5		98.7	100.0	99.68	98.1 100.00 98.46	
Through 200 mesh. (%)	From 71.45 to 97.06	83.0	95.9		From 66.5 to 96.0		75.3	85.6	92.41	77.0 86.5 89.37	

and Central Railway of Brazil, are now considering the use of pulverized fuel for locomotive service, the last named road having already decided to adopt it after an exhaustive three months' investigation made in the United States.

During the past year various fuels have been successfully burned in pulverized form in railway locomotive and stationary boilers performing regular service, and a list of some of these follows. The analyses are of the fuels when in pulverized form, ready for use.

**POWDERED FUEL**

Since the last meeting of this association the Chicago & North Western has equipped an Atlantic type locomotive for burning powdered fuel which is now operating in regular passenger train service between Chicago and Milwaukee and

Fourth—Saving of from 15 to 30 per cent in fuel of equivalent heat value fired.

Fifth—Enlarged exhaust nozzle area, resulting in greater drawbar pull and smoother working of locomotive.

Sixth—Elimination of a-shpit delays, facilities and expense and reduction in time required for, and ease in firing up

Seventh—Maintenance of a relatively high degree of superheated steam.

Eighth—No accumulation of cinders, soot or ashes in superheater or boiler flues, smokebox, or on superheater elements.

Ninth—No punishment or overheating of firebox, new or old sheets, seams, rivets, patch bolts, stay or flue beads.

Tenth—Elimination of arduous manual labor for building, cleaning and dumping fires.

Eleventh—Avoids expense and annoyance of providing various sizes and kinds of fuels.

Twelfth—Eliminates the necessity of front end and ash pan inspection and for special fuels, firing tools and appliances for building fires and for stoking and cleaning fires.

Thirteenth—Equal provision with engineer for fireman to observe signals and track, thus reducing liability of accident.

The committee is of the opinion that the effectiveness and utility of the use of fuel in pulverized form has been demonstrated from the past year's development, and that the progress in the use of this method of stoking and burning bituminous and anthracite coals and lignites for generating power, heat and light on railways will be quite marked from now on. The constantly increasing cost of railway fuel at the mine; the scarcity of fuel oil; the domestic and export demand for the larger sizes of coal; the prohibitive cost of briquetting the smaller sizes of coal and of lignite for railway use; the payment of labor on the run-of-mine basis for mining bituminous coals; and the necessity of eliminating smoke, sparks and cinders, will all tend toward the inauguration of this practical means and method for increasing the efficiency of steam boiler operation which today affords the greatest opportunity for improving locomotive and power plant costs and performance, and for changing public sentiment by smoke abatement.

The report was signed by: W. L. Robinson, chairman

It was stated that the cost of drying and pulverizing the coal would vary according to location and the amount of coal pulverized. One set of figures, given by H. G. Barnhurst, of the Fuller Engineering Company, for the Lehigh Valley district showed a variation of \$1.00 per ton for a mill of 10-ton capacity to 29 cents for a mill of 250-ton capacity, these costs including the interest and depreciation of the entire plant.

Of the various coals mentioned in the report as being used it was stated that the Kentucky bituminous and the North Dakota lignite gave very good results. Trouble was experienced with the Illinois bituminous due to the high percentage of moisture. Tests with the powdered lignite were especially successful, and this has a direct bearing on the roads in the Northwest. It was stated that one ton of powdered lignite at \$1.60 would give as good results as the same quantity of the eastern coals at \$4 per ton hand fired. A mixture of anthracite and bituminous coal is being experimented with on the Delaware & Hudson pulverized coal locomotive. At the present time a mixture of 40 per cent anthracite and 60 per cent bituminous coal is being used successfully and it is believed possible by further experimentation to bring this to 80 per cent anthracite and 20 per cent bituminous. In stationary plants 100 per cent anthracite powdered coal can be used. It was also mentioned that due to the methods of mine operation at the present time the



W. H. Averell, Vice-Pres.  
International Ry. Fuel Assn.



J. G. Crawford, Sec.-Treas.  
International Ry. Fuel Assn.



E. W. Pratt, Vice-Pres.  
International Ry. Fuel Assn.

(B. & O.); H. T. Bentley (C. & N. W.); W. J. Bohan (N. P.); M. C. M. Hatch (D. L. & W.); H. B. Brown (I. C.); D. R. MacBain (N. Y. C.); A. G. Kinyon, (Pow. Coal Eng. & Equip. Co.); H. C. Oviatt (N. Y., N. H. & H.), and L. R. Pyle (M., St. P. & S. S. M.).

#### DISCUSSION

The theory of the burning of powdered coal was likened to that for the burning of fuel oil, that is to say, the coal being ground to such a fine state enters the firebox of the locomotive in the same condition as the atomized fuel oil. If it is properly mixed with air, it will be immediately and completely consumed. The coal, however, should be properly prepared. It is necessary to have thoroughly adequate machinery for drying and pulverizing it to the proper degree of fineness. The coal should not contain more than one per cent moisture and should be of such fineness that 95 per cent will pass through a 100 mesh screen and 85 per cent will pass through a 200 mesh screen. While this degree of perfection was not obtained with the coal used on the Chicago & North Western locomotive there was a marked decrease in coal consumption shown in comparative tests. Without the proper dryness and proper amount of air it was found that slag and honeycombing would occur.

slack is obtained in larger quantities than ever before; this can be very advantageously used on powdered fuel installations.

Tests made on the Chicago & North Western showed that more than 30 per cent saving in the weight of coal consumed was obtained in the powdered coal superheater Atlantic type locomotive over a similar saturated steam locomotive hand fired and a saving of 15.92 per cent was shown over a similar superheated steam locomotive hand fired. The steaming capacity of the powdered coal locomotive was far greater, it being found necessary to replace the 3-in. safety valves with 4-in. safety valves to properly relieve the boiler. There was no difficulty in maintaining the full boiler pressure on the powdered coal engine and care must be taken, as in fuel oil locomotives, to avoid excessive popping. No difficulty was experienced in operating this engine in cold weather. With the application of the powdered fuel equipment the size of the exhaust nozzle was changed from 5 in. by 4½ in. to a round nozzle 5½ in. in diameter.

It was stated that no boiler repairs have been made that were attributable to the pulverized fuel installation. In the nine months the engine has been operating the tubes have been blown twice and the superheater unit ends remain clean. It has not been necessary to clean the smokebox during that

time. The arch tubes have been increased to 3½ in. in diameter to provide for the extreme heat of the firebox. It was found that the fire brick used in connection with the powdered coal equipment does not burn out nearly as rapidly as was first expected, due to the fact that there was no pronounced impinging action of the flame on the brick work.

The advantages mentioned for the use of the powdered fuel were the utilization of the cheaper grades of fuel, especially that now being absolutely wasted, a larger field for the use of lignite, less absolute fuel consumption, better utilization of the fuel, elimination of smoke, cinders and sparks, greater boiler capacity and greater safety in train operation due to the fireman being free to give closer observance to signals. This latter item was believed to be of great importance.

**LOCOMOTIVE MAINTENANCE AND FUEL ECONOMY**

By A. N. WILLISIE

Chairman, Fuel Economy Committee, Chicago, Burlington & Quincy

Every delay, every piece of careless or indifferent work to a locomotive on the part of road or shop or roundhouse men, every neglect of attention on parts of machinery wear, or boiler and flues allowed to become foul, all revert back to the coal pile. The boiler capacity and heating capacity should be great enough to more than fill the cylinder volume, as the engine cannot be 100 per cent efficient all the time on account of the varying condition of the fuel; the condition of the water; of the boiler and flues; inexperienced firemen, and men newly promoted to the position of engineer. Boiler repairs must not be neglected, as the boiler is the vital part of the engine. The heaviest drain of all the accessories on the boiler are the air compressors.

Many times from 10 to 15 per cent of the entire coal consumed on a trip is used to generate steam which is used by the compressors. Air compressors should be equipped with the proper kind of strainers to protect the air intake. Arrangements should be made so that it is possible to lubricate the air end properly. There should be no traps in the steam line between the supply valve and governor, or between the lubricator and the steam line leading to the compressors—yet how often this occurs! Another important factor is to see that the proper sizes of pipes and valves and governors are used for the different sizes of compressors.

The air compressor exhaust should be located so that the steam will not go directly up the stack, as when standing this creates a terrific draft on the fire, with same effect as a strong blower, resulting in a great waste of coal. I believe every engine should be equipped with a two-way valve, controlled from the cab, so that the pump exhaust can be turned into the tank, when so desired. Heating the water in tanks results in a saving of coal to the amount of one per cent for each eleven degrees of increased temperature.

It will surely pay well to cover the steam line to the air compressors' steam pipes with a good insulation; but better yet, put as much of the pipe as possible under the boiler lagging. According to Steam Power Plant Engineering, by G. F. Gebhart, Professor of Mechanical Engineering of Armour Institute:

"For most practical purposes the loss of heat from bare steam pipes or drums may be taken at 3 B.t.u. per square foot heating surface per hour per degree difference in temperature of steam inside and air outside."

From tests made by Dean Goss several years ago on a small engine with 61 per cent of the boiler covered, the loss due to radiation while standing was 18 lb. of coal per hour, temperature of the air being 80 degs. The loss at 28.3 m.p.h. was 37 lb. of coal per hour. On the same boiler with no covering the loss, standing, was 48 lb. of coal per hour. At 28.3 m.p.h. the loss was 100 lb. of coal per hour. This gives an idea of the importance of keeping the boilers

well lagged, and also of getting them out with the least terminal delay.

There seems to be a variance of opinion as to the losses due to the accumulation of scale in boilers. Some of the best authorities give the losses about as shown in the following table:

LOSS OF HEATING POWER DUE TO SCALE  
(Approximate)

Thickness of scale.....	1/64	1/32	1/16	3/8	3/16	1/4	3/8	1/2	5/8	3/4
Per cent loss of heating power .....	2	4	9	18	27	38	48	60	74	90

These figures are not considered absolutely accurate, as these losses are not found to occur in all boilers, because the whole of the boiler surface does not usually become covered; still the loss is always serious, apart from the stresses set up in the boiler plates.

I have been unable to obtain any reliable data as to the percentage of loss due to soot in flues on locomotives, but my opinion is that the amount of soot that will adhere to the inside of a flue will cause as much loss of heating power as 1/64-in. scale on the water side of flue, or 2 per cent, and any ash accumulating in the bottom of flues causes still a greater loss, according to the area covered. Prof. Ordway, in the Transactions of the American Society of Mechanical Engineers (Vol. 6, page 168), shows that there are only two materials that rank higher than soot as non-conductors of heat. The first is loose wool; the second is live goose feathers. Asbestos is thirteenth on the list.

A boiler should be washed regularly, using hot water with a pressure of about 100 lb. Begin early and keep at it, and do not allow accumulations of sludge. Nothing is gained by trying to get too many miles out of an engine between washings, as the boiler getting foul results in water being carried over into cylinders, ruining lubrication and packing; and the mud and scale in boilers reduce the absorption of heat.

Engines should be drafted and grated for the coal that is to be used, and the same grade of coal should be supplied as far as practicable. In this way the crews become familiar with the best way to handle the coal, and the engines will burn it more economically. The center of the nozzle must not only be plumb with the center of the stack, but it must be level, otherwise the exhaust steam will not properly fill the stack. In order that the nozzle and front end may perform their functions the flues must be kept clean and dry, and no leaks allowed in steam pipes, dry pipe connection or nozzle stand seat. When an engine begins to lag on steam, reducing or bridging the nozzle should be the last resort; the trouble is usually at some other place.

Flues should be cleaned every trip, especially on superheater engines. If the superheater flues are not free but little superheated steam will reach the cylinders.

Water losses should not be neglected. A total leak of but one pint per minute is 180 gallons per twenty-four hours. One hundred and eighty gallons per day is 65,700 gallons per year; this at 5 cents per 1,000 gallons represents a loss of \$3,285 per engine per year. One pint per minute is a very small leak, taking into consideration the leaks around tank, tank hose and injector overflows, etc. Water is wasted by carelessness in filling tanks; they often overflow to the amount of 100 gallons or more.

All steam leaks must be avoided, such as those in valves in cab, injector throttles, blower valve, boiler checks, surface blow-off valves, valve to headlights and heater valves. On engines in freight service equipped with train heating apparatus the steam valve in cab is usually cracked a trifle to allow some circulation, to avoid the line freezing up; this soon cuts the seat; then it is impossible to close the valve tight. On engines in this class of service I would suggest that a small by-pass valve be used, so that circulation may

be possible with no injury to the main and reducing valves. The expense of grinding in the small valve will amount to nothing compared with the other valves.

All steam joints in front end should be tested every thirty days. Leaks in front ends of superheater engines can be so bad that no superheated steam reaches the cylinders, yet the engine may work along, doing nearly as well as a saturated engine. If such leaks occurred with a saturated engine there would be a complete engine failure. Simmering flues soon honeycomb the sheets, reduce the heating surface and waste coal. Honeycomb must be removed from all parts of the firebox. It is often allowed to remain on crown staybolt heads.

Grates must be kept in good condition, so that they will work freely, and there should be no unnecessary openings, such as broken fingers. If the grates work hard the fireman puts the job of shaking off as long as he can, resulting in heavy fires and waste of fuel. Grates should be shaken only when necessary, and not too hard. They should be shaken only when the engine is standing or drifting in order to avoid tearing holes in the fire.

Arch tubes should be used. This not only gives more heating surface, but makes it possible to get many more miles out of the arch brick. Arches supported on studs do not last nearly as long, and when one brick goes down, at least one more (the opposite) goes with it; then the trip is continued with an arch of improper dimensions, resulting in loss of fuel. The saving in coal by use of an arch is not all due to the arch itself, as by the use of an arch the fireman is compelled to do a better job of firing than he might possibly do were there no arch in the firebox. The maintaining of a good arch of the proper height reduces a great deal of the front end losses, which are greater than generally considered; these front end sparks contain 25 to 40 per cent carbon.

The decks of the engines must be kept tight; no opening should be allowed around the pin hole or shaker levers and other places. A loss of 200 lb. per trip through such openings is very conservative with the average fireman. The same applied to the decks of tanks; and the shovel plate should be smooth, with no seams or rivets. Tanks should be built so that coal will be kept within easy reach of the fireman. There should be guards to prevent coal working out of gangways. Usually the coal space is longer than it is wide; if so, the tail board should be higher, or shaped to conform to the crown of the pile of coal on tender. The manhole on tender should be as long as allowable, so that the water crane spout will fit. This saves delay, also saves water and time filling the tank.

The stacks should be covered while in the house, to save heat and save the flues, and the boiler will hold steam much longer. If an engine is kept in good condition it is not only possible for it to do better work, but it encourages the engineer and fireman to do better work. When they are able to handle the trains faster the conductors and brakemen naturally get into the game, also the dispatcher, with the result that the crews are on the road less time, saving time and overtime, all of which saves coal, if the engine is not worked beyond the economical point.

#### DISCUSSION

Considerable stress was laid upon the necessity for maintaining the locomotive and the air brake equipment of the cars in proper condition. Applying the figure of \$.00015, given by Mr. Willsie in his paper as the cost for fuel for air leaks per car mile, to the total revenue car mileage in the year 1914, it was found that over \$3,000,000, or about 1.3 per cent of the total fuel bill, was spent in this way. It was also pointed out that by keeping the air leakage down it was possible to materially increase the length of trains, especially on the mountain grades.

While the effect of soot in tubes in locomotives was not definitely obtained, it was stated that in stationary practice it was found that the soot would collect cinders, forming gas pockets which insulate the heating surface of the tubes from the hot gases. In this connection it was stated that for every 20 deg. decrease in stack temperature there will be a saving of one per cent in fuel. The use of the pyrometer on superheater locomotives was strongly recommended as a device that would soon pay for itself due to the fact that the condition of a locomotive can be more accurately determined. Without the pyrometer it is difficult to determine whether the proper superheat is being obtained. The packing of the engine should be carefully maintained and the valves kept square. The proper maintenance of the arch and clean tubes have shown that savings of 10 to 15 per cent can be obtained.

#### FRONT ENDS, GRATES AND ASH PANS

*Front End.*—The taper stack seems to be the most generally accepted design. Many previous experiments have shown that this form is somewhat more efficient and also more "flexible" than the straight type.

The exhaust jet acts to move the gases by frictional contact, and by enfolding and entraining them. The whole surface of the jet, from the time it leaves the nozzle until it finally fills the stack, exerts this action on the gases, and hence it would seem logical to make the travel of the jet in the front end as long as possible. In other words, the highest stack with the lowest exhaust base should be the best combination. If a "basket" around the nozzle is not used (and there seems to have been some fault found with this design) the lowest limit of exhaust base will be that which allows sufficient gas area under the table plate, and no more.

The adjustable petticoat or draft pipe seems to be disappearing, and this is believed to be consistent. In place of the petticoat pipe the extended or drop stack is employed, with a generous flare at the bottom, and run as high above the nozzle as can be done and still clean the table plate. With this plan we do not believe that "over-draft" is necessary or desirable.

We wish to go on record as decrying the use of bridges or splits in exhaust nozzles. It is of course a fact that, if the over-all design is not right, a split may help to make an engine steam, but its use is at best merely introducing an evil to partly counteract another, which may, however, be basic. Any bridge or split increases cylinder back pressure, and hence is undesirable.

In general it may be said that: Taper stacks are desirable; the lowest possible exhaust base should be used; the adjustable petticoat pipe should be discarded; maximum netting area should be employed; bridges or splits should be avoided; "over-draft" should be eliminated, and the only adjustment (if any) to be made should be in the diaphragm apron.

*Grates.*—The grate is the mechanical supporter of combustion, just as oxygen is the chemical supporter, but nothing like a proportionate amount of study has been given to it. Material and design have generally been on a more or less haphazard basis, the iron used being whatever happened to come out of the cupola, and the design following general practice, which may or may not have had originally some good and consistent basis. There is no limit, from a combustion standpoint, to the air opening which could be permitted to advantage. We should endeavor to obtain as large an amount of air opening, evenly distributed through the grate bars, as can be done without mechanical loss of fuel. One road is experimenting with a grate of the non-interlocking, cross-rocking, finger type, in which an air opening of slightly better than 50 per cent is obtained. Besides improving combustion by reducing the restrictions imposed on the flow of air to the fire and distributing it more evenly

throughout the fuel bed, we may expect a reduction in clinkering.

The matter of interlocking versus non-interlocking fingers is one which is open to discussion. The interlocking type introduces features which may tend to cause unnecessary burning of grates, as the fingers are long, and it is a frequent occurrence for clinkers to catch between fingers of adjacent sections when they are rocked, either forcing them out of place or cocking them. This type gives, of course, a more pronounced "chopping" action on the fire than the non-interlocking, but with most coals if a consistent thickness of fire is carried and excessive hooking (tending to cause clinker) is not indulged in, the non-interlocking type offers advantages which are worthy of consideration.

Grate fingers in transverse cross-section should be approximately sections of a frustrum of a cone, with the base up. This shape gives better air inlet conditions than if fingers are rectangular in section, and also allows the grates to clear themselves to much better advantage, as the space between the fingers, through which ash and refuse must pass, is of constantly increasing area below the grate surface.

The material used in making grate bars should be cast iron of maximum strength commensurate with toughness, small shrinkage and high melting point. As a rule it is difficult to control with any degree of exactness the mixture from which grates are cast, as special heats are seldom run for this purpose, the ordinary practice being to use the general casting mixture. Some study has, however, been given this matter, and the committee would tentatively recommend the following analysis:

Silicon .....	1.20 per cent to 1.40 per cent
Phosphorus .....	not over .50 per cent
Manganese .....	.75 per cent to 1.00 per cent
Sulphur .....	trace to .10 per cent

Experiments with a mixture approximating the above have been made with good results, although they have not been carried far enough as yet to give any comparative figures.

*Ash Pans.*—The committee recommends the largest possible amount of air opening in the ash pan, with a minimum of one square foot of opening for each 7 sq. ft. of grate area, or a percentage of about 14, this holding for bituminous coal. For anthracite, 50 per cent of the above ratio may be used. Two locomotives, recently tested at Altoona, Pa., having identical boilers, but with, in one case, an ash pan air inlet area of 12.2 per cent of grate, and in the other of 11.1 per cent, a difference of 10 per cent, showed efficiencies throughout the entire range of fuel rates 4.5 per cent greater for the first than for the second.

Ash pan volume should be as large as consistent with the design of the locomotive, and not less than 1.25 cu. ft. for each square foot of grate area. In many cases, on large power, this will mean multi-hopper pans, but these are to be desired rather than to sacrifice necessary space for simplicity of design. A small pan will, under some conditions, seriously affect the steaming qualities of the boiler. A point in favor of multi-hopper pans is that in such a design it is possible to make all slope sheet angles greater than the angle of repose of ash. This again tends to keep air intakes free and to reduce burned grates, and also does away with the somewhat common practice of flushing the flat pan sheets by a stream of water, which is bound to have a bad effect on hot cast iron grates.

*General.*—The heat loss in the furnace offers a great field for investigation. We lose heat here, first, by sparks and cinders; second, by the escape, unconsumed, of certain CH<sub>4</sub> series hydro-carbons; third, by CO; fourth, by combustibles through the grates; and fifth, by radiation at the grate.

The most efficient furnace design can be reached by the use of large grate areas, by large combustion chambers, and by allowing the admission of plenty of air (there should not be less than 50 per cent excess) through grates and ash pans. The large grate area will reduce the rate of combustion at

maximum boiler outputs and thus reduce spark losses (which are proportionate to fuel rate) and CO losses. The combustion chamber will shorten the tubes, will increase the heat absorbed by the firebox, will lower the gas temperature entering the tubes (and hence the front end temperature, which is a measure of efficiency) and will conduce to better mixing and burning of the elements of combustion. An excess of air, obtained without restriction, is a prime necessity for perfect combustion, and it is not believed that, within reason, it exerts a deleterious effect on firebox temperature and evaporation.

The velocity of the gases through the tubes has an important bearing on the capacity of evaporation of the tube heating surface. Other conditions being equal, the evaporation increases almost directly as the velocity of the gases increases, while the efficiency decreases but very little after the point of critical velocity has been reached.

At ordinary or low speeds the gases seem to flow in stream lines, and that portion of the gas nearest the metal becomes cool and tends to act as a sort of insulation against the hot gases flowing through the center. When the critical velocity is reached this stream flow is broken up by violent eddying, which tends to mix the hot and cool particles and increase the rate of heat transfer.

The report was signed by: M. C. M. Hatch, *Chairman*, (D. L. & W.); Ralph Bradley, (B. & M.); E. B. De Vilbiss, (Penn. Lines); W. F. M. Goss, (Univ. of Ill.); H. B. McFarland, (A., T. & S. F.), and J. P. Neff, (Am. Arch. Co.).

DISCUSSION

L. R. Pyle, of the Minneapolis, St. Paul & Sault Ste. Marie, called attention to the fact that some of the States are requiring a legal standard for the size of openings and size of wire for the front end netting, in order to reduce the liability of live sparks passing from the locomotive. He stated that the oblong mesh gave better results than the square mesh in that the cinders are broken up to a greater extent before leaving the front end, and that a greater opening was obtained with the attendant less resistance to the draft. Recent tests have shown a decrease of six per cent in the amount of steam used to do the same amount of work after the nozzle tip had been increased 5/8 in. in diameter, which was due to the reduction in back pressure in the cylinder. It was also stated that the relation of the height of the table plate to the top of the tip was of importance. The Santa Fe finds that by placing the table two inches below the tip the best results are obtained. The question of grate and ashpan opening was discussed to some extent, and particular stress was laid upon the necessity of having these openings as large as possible.

FUEL STATIONS

At the last meeting of the association, it was suggested that some reliable automatic means and devices might be cheaply installed, operated and maintained; not only on new plants being installed, but also to plants that are in operation; and also that certain devices might be developed to provide automatic and reliable record of the actual amount of coal issued by each plant to each locomotive and engineman. At that time, reference was made to a certain device for weighing and measuring coal, and since then the committee has endeavored to urge all manufacturers to complete their studies and plans, and we are submitting the results of the year's work.

DESIGN A

This measuring device consists of a square box holding a full ton of coal. At the back of the box is located a curved undercut gate to cut off the flow of coal between the coal pocket and the measuring device. The front of the box is closed by means of a gate hinged at the top; both openings

in the box, front and rear, are of ample size to allow the coal either to escape quickly or to flow into the box quickly, whether small or large coal is used. The two gates operate alternately—that is, when the back gate is open, allowing coal to flow from the pocket into the box, the front gate is closed, and *vice versa*. Both gates are positive in operation, and the device may be operated either by hand power, by electric motor, air, steam or other power. An apron is hinged to the bottom of the box at the front in such a manner that it may be swayed from side to side. This distributes the coal evenly over the tender without moving the locomotive.

The workable cycle of operation of the measuring device has been found to be four measures or tons per minute when operating by power. If operated by hand the number of measures per minute would be reduced.

The measuring device is provided with a revolution or cycle counter, registering one ton for each cycle of operation. Each fireman on the arrival of his locomotive at the coaling station records the number of tons shown on the counter. He then takes as many tons as he requires and records on his ticket the final number of tons as shown by the counter. The difference between the two records indicates the amount he has received. By this method each fireman's record is a check on the one preceding and the one following his locomotive.

This measuring device has been designed with the object

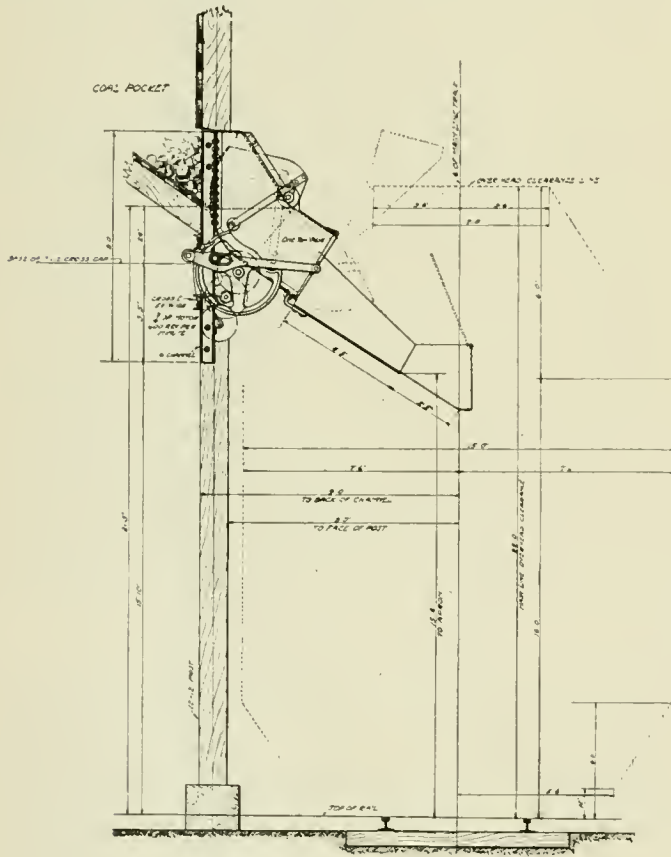

Device for Coaling Stations

in view of its being attached to existing structures without any appreciable alteration to them. It has also been designed to conform to standard track clearance lines.

DESIGN B

The measure is constructed in such a manner that it can be attached to the present stations without loss of elevation or standard clearance, as there is no change in the main slopes of the storage bin floor. The only change necessary is the side slopes and an additional small baffle over the measure, which can be changed at a nominal cost.

The measure is of half-cylinder design, pivoted in the center, with a gate at one end and a cut-off at the other. The bottom is provided with an additional plate extending from the cut-off to the center or pivot, and is located so that it continues the slope of the bin floor when in a filling position, also providing a very steep slope when the measure is in a discharging position, causing a quick delivery of the coal. The main bottom of the measure extends beyond the cut-off plate, and forms a pocket to catch the fine coal that might pass by the cut-off. All coal caught in the pocket is passed to the measure when discharged through the opening under the cut-off. The measure is held in position by a

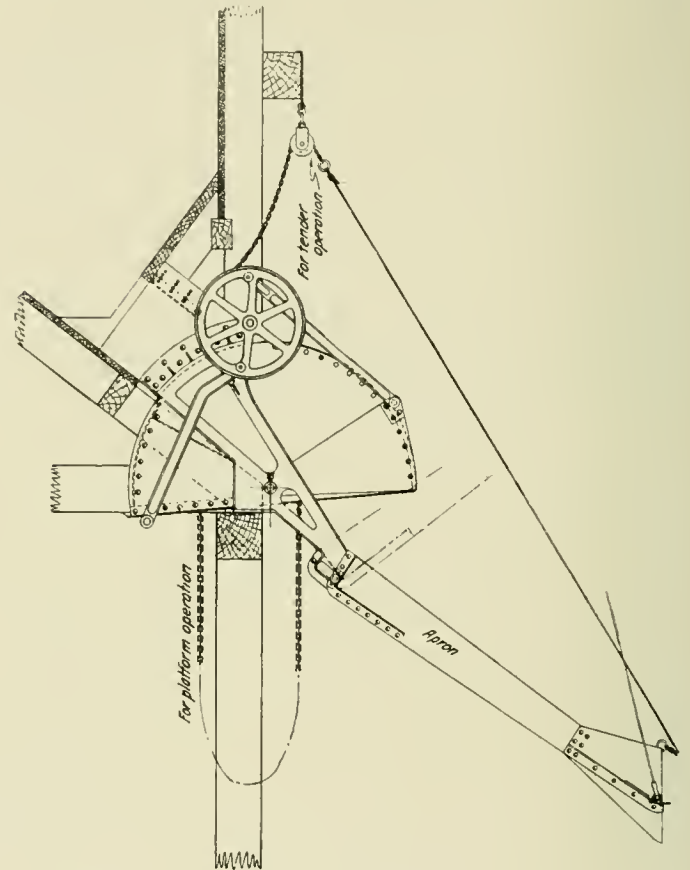

Coal Measuring Device

pivot shaft which is attached to the bottom and passes through the two steel side castings, these castings being securely attached to the building at the pivot and upper end. The lower end of the side castings is provided with a cross-connection, and attached to same is a hinge or pivot to support the delivery spout.

The measure is operated through the link connections by rotating the sheave wheels, the links forming a toggle as the pivots pass over dead center, holding the measure in a locked position until the wheel is rotated by the operator. The measure is counterweighted sufficiently to cause it to return to the filling or horizontal position. The coal flowing into the measure causes the center of gravity to change to the front or discharging position, and it will immediately tip and discharge the load when unlocked, by rotating the wheel out of the toggle position. In the discharging of the coal or returning to a loading position, the link connection to the rotating wheel eliminates all slam or shock to the measure, as the movement is gradually reduced as the links pass over dead center. When the coal is discharged the measure automatically returns to the filling position and is again locked by the toggle links. The operation of the measure is produced by a slight pull on the rope or chain to rotate the wheel

causing the link pivot to pass dead center, the weight of the coal causing the measure to tip.

The capacity of the measure is one ton, and the movements are about eight to the minute. Attached to the measure is a recording device which records each issue to the engine, also a total record of the amount of coal passing through the chute. The measure is simple and strong in construction and cannot get out of order, and can be operated by hand from the tender or a platform, or power can be attached when desired.

The report was signed by: H. J. Slifer, chairman (Cons. Eng.); E. E. Barrett (Roberts & Schaefer Co.); H. B. Brown (Ill. Cent.); W. E. Dunham (C. & N. W.); J. C. Flanagan (Fairbanks-Morse & Co.); G. W. Freeland (Williams, White & Co.); W. T. Krausch (C., B. & Q.); R. A. Ogle (Ogle Const. Co.); J. L. Rippey (C., M. & St. P.), and A. Warner (Link Belt Co.).

#### DISCUSSION

The moral effect of weighing the coal on the tender of a locomotive was believed to have a very beneficial effect on the engine crew. Tests have shown that where the enginemen know that they are being checked upon the amount they use, a 10 per cent saving will result. It also serves to keep a more careful check on the condition of the locomotives. There was some disagreement regarding the measuring of the coal by volume as against obtaining the true weight of coal used. It was pointed out, however, that the volumetric devices could be adjusted for the different grades of coal used, so that the error would be slight. Tests on the type A machine shown in the paper, which was installed April 7 on the Nashville, Chattanooga & St. Louis, and had distributed 4,623 tons, showed that there was less than one per cent error per ton.

It was believed as necessary to weigh the coal into the coal chute as it was to weigh it out, as by this means a more definite check can be obtained on the coal used. In making adjustments for the overage or shortage, it was believed far better to adjust through a profit and loss account rather than to apply a correction to each individual engine, as it was much fairer to the engine crew.

A device for measuring the coal on the tender was mentioned by M. C. M. Hatch, of the Delaware, Lackawanna & Western, which was in the process of experimentation. He believed that this system would be of material advantage in that the men could constantly be informed as to the amount of coal they are using throughout the run. This device is such that the coal container in the tender is supported on diaphragms which are supported by a fluid. The pressure of this fluid is registered on gages which show the weight of the fuel container.

#### INTERPRETATION OF COAL ANALYSIS

BY E. G. BAILEY

The purpose and value of coal analysis should be better understood. The man who is responsible for the buying or burning of the coal accepts the figures from the chemist for the purpose of comparison, and proceeds to draw certain conclusions as to the relative value of the coals under consideration according to his own ideas of what the chemist's figures really mean. Very often these conclusions are not borne out by the practical road tests or the actual use of the coal in regular service.

It is regretted that too often the results of the chemical analysis are wrong, not by insignificant fractions of one per cent, but by several per cent or several hundred B. t. u. Very frequently the trouble is in the sampling, the original sample not being large enough to be truly representative, or else not having been properly reduced and pulverized. The methods of sampling and analysis recently proposed by com-

mittees of the American Society for Testing Material\* and the American Chemical Society, should be carefully considered.

The cost of fuel alone is not the sole criterion on which to judge the value of the fuel, for the character of the fuel has a great deal to do with the cost of repairs to grate bars, furnace linings and arches, and is of very great importance in the case of locomotive practice.

While the heating value of a fuel may be the item of primary importance, yet the effect of the non-combustibles upon the action of the coal in the firebox has such a modifying influence that very frequently the coal with the higher heating value gives the poorer results.

The usual analysis of coal gives the percentage of moisture, volatile, fixed carbon, ash and sulphur, in addition to the heating value. The moisture is of course a non-combustible. The principal importance of moisture is that it acts as so much inert matter, which is paid for at the same price as coal. This applies only to the moisture which is in the coal at the time of its being weighed.

According to the best authorities all of the oxygen which occurs in coal and which is not shown in the analysis as moisture is included in the volatile. By dividing the volatile matter of a typical West Virginia gas coal into its different elements, hydrogen, oxygen, carbon, nitrogen and sulphur, it is found that in the volatile there is a total of 5.38 per cent of the total coal, or about 13 per cent. of the volatile, that is water, besides some nitrogen and sulphur as non-combustibles. Making a similar division of the proximate analysis of a typical Illinois coal, we find that 9 per cent of the total coal occurs in the volatile in the form of water, or 25 per cent of the volatile itself is non-combustible. In the case of lignite and peat, the percentage of volatile which is non-combustible proportionately increases. So that in this we see that volatile itself is not an indication of rich locomotive fuel.

The question of clinkers is one of the very vital problems in locomotive practice. The whole question of clinkers can be summed up in the fusing temperature of the ash and the temperature to which this ash is subjected. Clinker accumulates gradually, and is more or less open and does not obstruct the air beyond the critical limit. But slicing or working the fire, causing the ash, which has already been liberated from the coal in the lower and cooler part of the fuel bed, to be again thrown up into the hotter zone, will melt it into a very fluid mass and obstruct the air flow to a serious extent.

Many people have considered that the percentage of sulphur was a true indication of the clinkering property of a coal. Sulphur is an indirect cause, however, for it is really the iron which has the effect upon the fusing temperature, and the percentage of iron usually increases or decreases with the sulphur. There are so many exceptions to the relation between sulphur, or even iron, and the clinkering property of coal, however, that a dependence upon either is apt to lead to erroneous conclusions.

The percentage of ash and its clinkering property is the critical factor to be considered in comparing the commercial value of different fuels of the same character. When it comes to comparing coals of different character practical tests are the only reliable means of arriving at comparative results.

#### DISCUSSION

It was generally agreed that ordinarily the sampling of coal was very poorly done which gave erroneous results. A mechanical sampling device being tested at the University of Illinois was believed to satisfactorily solve this difficulty. Some advanced the idea that the oxygen compounds were of

\*Proceedings American Society for Testing Materials, Volume XV, Part 1. Also Year Book 1915.

advantage in that they assisted in the combustion of the coal. The trouble from clinking will be materially reduced if sufficient air is allowed to pass through the grates and thoroughly oxidize the iron content in the coal. One coal operator believed that the best results would be obtained from analyzing the coal at the face of the mine, determining the percentage of foreign matter in the vein and using this as a check on the fuel delivered, inspections being made occasionally of carloads of coal to determine the percentage of foreign matter.

### FUNCTIONS OF A RAILROAD FUEL INSPECTOR

BY EUGENE McAULIFFE

General Coal Agent, St. Louis & San Francisco

The function of the fuel inspector will vary with the conditions surrounding the source of the railroads' fuel supply. For convenience I will attempt to divide the more important duties of the inspector under certain subheadings:

*What Constitutes Inspection.*—Assuming that the inspector has been provided with copies of contracts, the enforcement of grade specification still remains in so far as results are concerned, a relative matter; in other words, the ideal can only be attempted, and the degree of success attained is best determined by comparison. The greatest controllable losses in quality of fuel lie in the direction of excess moisture and ash content, and where sulphur and its concomitant refractory ash making constituents occur in large quantities, a general attempt at excess ash control will usually in turn keep all such down.

It is entirely possible to equip every fuel inspector with simple apparatus and a formula easily understood, which will make the determination of ash and moisture content within reasonable limitations easily obtainable. United States Geological Survey Bulletin No. 621-A, "Field Apparatus for Determining Ash in Coal," by C. E. Leshner, Department of the Interior, U. S. Geological Survey, describes in simple language the apparatus and practice necessary to conduct this test.

*Car Supply.*—When cars are placed and the men are in the pit and on the tippie the production of a coal mine may commence; at the moment the car supply is exhausted the mine stops producing. No man can do more to raise the standard of this branch of mine service than can the competent fuel inspector, who works closely with the yardmaster, despatcher or superintendent who handles this work. The time lost by holding cars at mines, including delays incident to cars left over, empty or partially unloaded, unbilled loads, etc., is astonishingly large; an average delay of five or six days in moving all cars in and out of many mining districts is not uncommon. No railroad can own an average capacity coal car at an expense of less than 60 cents per day, counting interest, depreciation, taxes and repairs; too many men confound the agreed per diem rental with the cost of owning a coal car; they are dissimilar quantities, and when cars are in sharp demand \$2 to \$3 per day is not an excessive value to put on one.

*Proper Carload Weighing.*—The fuel inspector can assist materially in improving the standard of track scale weights, particularly when weights are made on scales located near the tippie. Perhaps the greatest service that he can confer on the traffic and operating department is that of assisting in the enforcement of the work of loading coal and coke cars to their full carrying capacity.

*Inspection of Anthracite Coal.*—A sufficiently competent inspection of a limited tonnage of anthracite can be made by:

(a) Observing the per cent of coal under size, including pea and buckwheat sizes.

(b) Note the percentage of rock or slate, readily removable, that is mixed with the coal.

*Inspection of Fuel Oil.*—Fuel oil should be purchased

under specifications, and the inspector should be provided with a standard Fahrenheit thermometer, a Baumé or specific gravity gage and a standard centrifuge testing machine. The thermometer is used to determine the temperature of the oil in storage tank or tank car, and when it varies from 60 deg. F. due allowance in gallonage should be made from a basis of 60 deg. F. The centrifuge testing machine, easily managed, is used to determine the percentage of water and sediment contained in the oil. Unless care in unloading is exercised many cars will go back to the loading rack with a material amount of oil left in them; this due to unloading cars standing on grades, carelessness in cold weather, etc.

*General.*—A fuel inspector who is competent will organize his work and indirectly create a staff of helpers at each mine or storage pile. The fuel inspector should be able:

(a) To establish a proper standard of quality.

(b) To measure results quickly and accurately.

(c) To make the mine employees his willing helpers.

(d) To impress all with the fact that it is not his desire or intention to spend one day on one certain coal tippie, the next on another, and so on to the end of the month, getting a 10 per cent result, but on the other hand, to establish and secure automatically a standard of efficiency instead.

### THE HUMAN FIREMAN

BY RALPH BRADLEY

Inspector of Fuel Service, Boston & Maine

There are two big problems in the efficient operation of the motive power department of a railroad—the "mechanical" and the "human" problem. In the mechanical problem we find that the machine (let us say a locomotive or an automatic stoker) has no initiative; it will not run itself, but power must be generated and furnished from some separate source. With the man (let us say a fireman or an engineer), however, it is a different problem. Initiative or power is a part of him and cannot be supplied from the outside. It is a man's will and mind and nervous system which provide the power to make him do the work, and the adequacy of this impelling force and its transmission to the physique is just as necessary to the man as the power is to the machine. Just as careful specifications, examinations and tests should be made covering mental and nervous processes of employees in engine service, as are made covering the generation of mechanical power, and the sooner such steps are taken the sooner will a great light be shed on the mystery of the "human equation."

We hear it said that men are not the "same class" today as they used to be. There are just as many good men as before if you want to get them. If we do not get them, it is because we do not attract them, which is not their fault, but the fault of the job or the fault of the employer.

Why should not the new firemen be examined as to their mental and nervous qualifications? It is the mental traits and disposition which are the essential ones. The mind and nervous system lie beyond and control the action of everything which the surgeon examines.

Theoretic training, though not indispensable, should be given greater prominence than heretofore, if 100 per cent efficiency is to be approximated. Assuming that the candidate for fireman is chosen or at least held as a student, he should be trained in theory. The fact that he is not a high school or a university graduate, and probably has small appreciation for theory, is no reason why he should be spared the work of learning important theories. The normal man has the curiosity instinct, which we have all inherited from our savage ancestors. If you do not tell him the "why" he is very apt to work out some theory of his own, with extraordinary results. The ordinary run of men are more inclined to absorb through oral instruction, visualization and practical demonstration than by literature. For this reason it is diffi-



cult to conceive a more practical method of imparting theories than by use of the lecture and demonstration car.

Whereas theoretic training is to explain *why*, practical training is to explain *how*. Practical training of a new fireman is indispensable, and specially so at the very start. It is far more important that the fireman should habitually strive to keep his fires as light as is consistent than that he should grasp the scoop in this way or that. It is far more important he should habitually study the condition of his fire and strive to place each scoopful of coal on that part of the fire bed where it will do the most good than that he should fire according to some system. The best practical training to fit a fireman to meet the variable conditions always present in locomotive operation is on the deck of the engine.

The first five trips of the new man on the engine are his habit-forming trips; they are more important in their effect on the direction of his habitual attitude toward his work and toward the welfare of the company, and in their effect on his sense of duty and responsibility and on his character than any other five trips of his life. Not every road can afford to carry enough road foremen or assistant road foremen or fuel supervisors (call them what you will) to accompany each new man for five trips, nor is it necessary; but no road should under any circumstances permit a new man to make his student trips with any but the very best engine crews.

The fireman should be required to pass a series of progressive examinations dealing with questions pertaining to both theory and practice in locomotive and train operation. At the same time he should be required to pass a physical and mental examination under a specialist, particular attention being given to a test of both sight and hearing. It is not until such tests and examinations have been made, and the result combined into some compact and readily available form, that a railroad can claim to have inspected the condition of its firemen with any degree of completeness.

Unless supervision and inspection under service conditions is much closer than it has been in the past, countless opportunities to commend efficiency and criticize inefficiency will continue to be lost, and with the same effect. The individual fuel performance statement, either with or without bonus, provided it is thoroughly reliable and gives credit for all the many factors entirely beyond the control of the fireman, is an excellent method for encouragement; but unless the fireman has the utmost confidence in the accuracy and fairness of the figures, even though the man who orders their compilation thinks them perfect, the statement fails to encourage, and may even discourage. It is an indisputable fact that the least laborious and most economical way to fire a locomotive is according to correct principles.

A series of interesting tests was conducted by two large eastern railroads, covering this feature of this subject. On each road a careful record was kept of the fuel performance of ten firemen on a number of trips under similar conditions. On part of the trips the firemen were unaware that they were under observation, whereas on the balance of the trips the test conditions were apparent. The following results, expressed in percentage, were obtained.

Average of test trips, Road A.....	100
Average of test trips, Road B.....	100
Average of service trips, Road A.....	131
Average of service trips, Road B.....	133

For one reason or another, the variety of duties which a fireman used to be required to perform have been reduced in number, so that today the fireman has as his particular job but one object—to maintain full pressure and to make the fuel supplied to the firebox evaporate into steam as much water as possible. As expressed by President Buell, "There is nothing more discouraging to a good fireman than an engine that will not steam properly. But a poor steamer seems to have some hypnotic effect on a poor fireman or a new man that not only causes him to forget everything he has ever known or heard about correct principles of firing, but sug-

gests that he is no longer a fireman, but merely a coal heaver—and he acts on that suggestion." If the co-operation of the fireman is desired, co-operation must be given.

DISCUSSION

In the matter of hiring men for the position of locomotive firemen, it was believed that too much care could not be taken in selecting the right kind of men. The hiring should be done by experienced men, such as road foremen, master mechanics, etc., and a record should be kept of applicants most suitable for the work so that they may be called upon on short notice. The new men should be required to work in the roundhouse a sufficient time to familiarize themselves with the work required to be done on a locomotive. The locomotives should be maintained in proper condition, for a poor steaming engine will discourage the engine crew in making any attempt to save fuel. Instruction books and reading matter, if properly handled, it was believed would be of considerable assistance to the firemen. Only by treating the men in a fair, intelligent way is it possible to obtain the proper co-operation.

OTHER BUSINESS

Two other papers which interested particularly the transportation department were presented; one by W. H. Averell on "What the Transportation Official Can Do to Promote Fuel Economy" and the other by J. G. Crawford on "Coal Distribution Record System."

A paper was also presented by A. G. Kinyon of the Powdered Coal Engineering & Equipment Company on the "Influence of Intimate Knowledge of Coal on Fuel Economy Efforts of Enginemen and Others." Mr. Kinyon performed practical experiments showing how the constituents of coal may be burned efficiently. A half a pound of coal slightly dampened was heated in a retort and it was shown how the moisture was driven off before any of the volatile matter. The gases coming off from the coal were burned, and it was shown how with inefficient air supply considerable smoke was produced. This gas was also passed through a scrubber removing all impurities and it was also shown how this colorless volatile gas could be made to burn, producing smoke by being in contact with a cold surface. It was believed that if such experiments were shown to the men actually handling locomotives it would give them a clear idea of the properties of the fuel they have to deal with.

Progress reports were submitted by the committee on Fuel Tests, Fuel Accounts, and on the Storage of Coal. The Committee on Fuel Tests reported that about \$2,000 has been obtained for the purpose of conducting the tests at the University of Illinois testing plant, and that the committee had been assured of the co-operation of the University of Illinois and the United States Bureau of Mines. George A. Post, president of the Railway Business Association, made an interesting address at the annual banquet.

The secretary-treasurer reported a total membership of 636 and a cash balance of \$1,940.11 up to May 1, 1916. During the convention 68 new members were enrolled. The proportion of attendance at the convention to the total membership was greater than ever before in the history of the association. The following officers were elected for the ensuing year: President, W. H. Averell, general manager New York properties, B. & O.; vice-presidents, E. W. Pratt, assistant superintendent of motive power and machinery, C. & N. W.; L. R. Pyle, fuel supervisor, M., St. P. & S. S. M., and W. L. Robinson, supervisor fuel consumption, B. & O.; executive committee, for two years, A. N. Willsie, C. B. & Q.; T. Duff Smith, G. T. P.; R. R. Hibben, M. K. & T.; Ralph Bradley, B. & M.; C. M. Butler, A. C. L.; for one year, William Schlafge, Erie Railroad, and W. K. Kilgore, C. M. & St. P. Chicago received the largest number of votes for the next place of meeting.

# LOCOMOTIVE IMPACT TESTS

By C. B. YOUNG

Mechanical Engineer, Chicago, Burlington and Quincy

The Chicago, Burlington & Quincy purchased seventeen 2-10-2 type locomotives in 1914 and 1915, and 15 Pacific type locomotives in 1915, which were built with reciprocating parts made of special heat treated steel in order to reduce the amount of counterweight ordinarily required to balance these parts. Last September impact tests were conducted on a three-track 63-ft. plate girder skew span bridge to determine the effect these locomotives had on bridges and track in comparison with locomotives of approximately the same size and design with reciprocating parts made of ordinary steel. In making the tests the railroad company was assisted by W. S. Kinne of the University of Wisconsin, who has had considerable experience in tests of this nature.

## DESCRIPTION OF THE LOCOMOTIVES

Four locomotives were used in the tests, two of the 2-10-2 type and two of the Pacific type. The locomotive of the 2-10-2 type provided with the special heat treated steel reciprocating parts is designated as M-2-A and the other having the ordinary steel, as M-2. Similarly, S-3 designates the Pacific type locomotive having the special heated treated steel reciprocating parts and S-2 the locomotive of the same type using the ordinary steel for these parts. Both of these types have been described in the *Railway Age Gazette*, the 2-10-2 locomotives in the issue of August 13, 1915, page 275, and the Pacific type locomotives in the issue of August 28, 1914, page 387. The locomotives are of the following general dimensions:

The M-2-A locomotives have .40 per cent carbon steel (electric process) pistons and crossheads (the crossheads being of the Laird type to reduce the weight), Nikrome steel piston, main and side rods, Nikrome steel main crank pin and nickel steel crosshead pins. The S-3 locomotives are similarly equipped with the exception of the crosshead pins which in this case are of Nikrome steel. The piston rods on both engines have a 2 1/2-in. hole through the core and the

## TEST METHODS

In order to determine the actual conditions existing for the locomotives under comparison, recording extensometers were used to measure the actual stresses in the girder flanges of the bridge, and the actual deflection of the girder was determined by means of a recording deflectometer. A comparison of the stresses and deflections caused by any two locomotives gives an idea of their relative impact effect. In order to secure data from which a comparison can be made as to the relative impact effect of any two locomotives, it is necessary to realize certain conditions. The speed at which the two locomotives are run must be equal, and the counterweights on both locomotives must be in such a position that their maximum downward thrust due to centrifugal force is exerted at

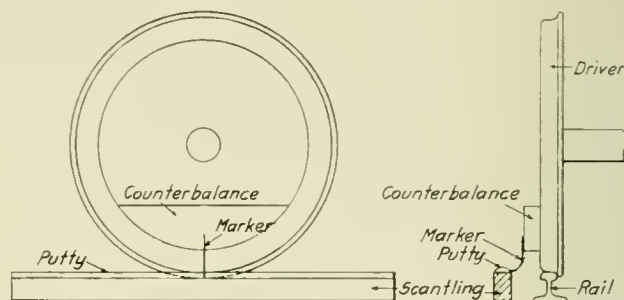

Fig. 1—Arrangement for Determining Location of Counterbalance Relative to the Center of the Bridge Span

the same point on the bridge. The method followed for obtaining the data was to determine the points on the bridge at which the counterweight was in the down position and to determine the speed at which the locomotive was running. In making comparisons, records were selected from the test runs where the locomotives to be compared were running at the same speed, and where the counterweights came down at the same point on the structure.

The determination of the position of the counterweights was accomplished by placing a marker on the counterweight

Class	2-10-2		Pacific	
	M-2-A	M-2	S-3	S-2
Reciprocating parts	Light	Ordinary	Light	Ordinary
Total weight	367,850 lb.	377,100 lb.	266,400 lb.	226,100 lb.
Weight on drivers	295,950 lb.	300,700 lb.	169,700 lb.	153,100 lb.
Size of cylinders (diameter and stroke)	30 in. by 32 in.	30 in. by 32 in.	27 in. by 28 in.	25 in. by 28 in.
Boiler pressure	175 lb.	175 lb.	180 lb.	165 lb.
Diameter of drivers	60 in.	60 in.	74 in.	69 in.
Tractive effort	71,500 lb.	71,500 lb.	42,200 lb.	35,600 lb.

maincrank pin a 4-in. hole. On the M-2-A locomotive the weight of the reciprocating parts is 379 lb., or 16 per cent lighter than the reciprocating parts on the M-2 locomotive. Similarly the weight of these parts is 73 lb. (5.33 per cent) lighter on the S-3 locomotives than on the S-2 locomotive. While the difference in this case appears small it must be noticed from the table below, that the S-3 locomotives are heavier and more powerful than the S-2 locomotives.

The M-2-A locomotives were built with these light reciprocating parts for the purpose of decreasing the effect on the track of the heavy counterweight required by the M-2 locomotives and to eliminate the use of the bob weights which were applied to the driving axles of the M-2 locomotives as a necessary addition to the counterweight in the wheels, the size of the wheels being such that the entire counterweight could not be contained therein. The S-3 locomotives were built with the light reciprocating parts for the purpose of obtaining heavier and more powerful engines than the S-2 locomotives without increasing the impact effect of the wheel load and counterweight on the track.

of the main driver. Alongside the rail was placed a scantling with a strip of putty on its upper edge. The scantling was so placed that the marker on the counterweight made a mark in the putty as the locomotive passed over the bridge. (See Fig. 1). The span center was used as a reference point, and the position of the counterweights is given in feet east or west of the span center. This information is given in the tables under the columns headed "C. B." Another column gives the speed in miles per hour at which each run was made. These speeds were determined by a stop-watch timing over a 1,000-ft. base line.

The detail results were worked up from the records of the recording extensometers and the deflectometer. By scaling the maximum ordinate from each record, the maximum flange stress or deflection caused by the locomotive is obtained for the test run in question. These are given under "M" in the tables. To obtain the impact effect the stress or deflection caused by the locomotive running at high speed is to be compared with values caused by the same locomotive running at low speed. These low speed records were taken for the loco-

motive crossing the bridge at a speed of about 5 m. p. h., for it has been found that at this speed the centrifugal force due to the counterweights is practically zero. In each series of test runs for a certain locomotive, the first and last runs were made at low speed, and are called "static" runs. The average values for these static runs are given in the columns of the tables headed "S." By subtracting these static values from the maximum values the excess due to the centrifugal force of the counterweights is obtained. In the tables these values are given in the columns headed "E." Finally, by dividing the excess by the static values, the "impact per cent" is obtained, the values of which are given in the columns headed "per cent E."

The instruments used in making the tests were two recording extensometers and one recording deflectometer. A complete description of these instruments is given in Bulletin No. 125 of the American Railway Engineering Association. The instruments were placed at the center of the top flange

of the north girder supporting the center track. Extensometer No. 11 was placed on the north edge of the flange, and Extensometer No. 12 was placed on the south edge of the flange. The deflectometer was placed at the center point of the top flange of the girder.

tives, but as the counterweight positions were not similar no comparison can be made. It seems probable, however, that the conclusions reached from Table II still hold true for high speeds. At 65 m. p. h. the maximum observed impact for the S-2 locomotives was from 35 to 40 per cent and for the S-3 locomotives from 30 to 35 per cent. As stated above, in designing the S-3 engines, it was desired to produce an engine of greater tractive effort and greater weight on drivers than the S-2 engine, without producing greater stresses on track and bridges. These tests developed that the S-3 engines having 16,600 lb. greater weight on drivers and 6,600 lb. greater tractive effort, actually produce less stress on track and bridges than the lighter S-2 engines with which they were compared.

*General Conclusions.* Where the locomotives are of equal weight, the locomotive with heat treated steel moving parts is not as hard on bridges and track as a locomotive with ordinary steel moving parts. The use of heat treated steel mov-

TABLE I—DATA FOR COMPARISONS BETWEEN CLASS M-2-A AND M-2 LOCOMOTIVES

Class	Speed, m. p. h.	C. B.	Extensometer No. 11				Extensometer No. 12				Deflectometer				
			M	S	E	Per cent E	M	S	E	Per cent E	M	S	E	Per cent E	
A	M-2-A	41.1	6.1 W	7,730	7,020	710	10.1	4,640	4,450	190	4.3	0.275	0.260	0.015	5.8
	M-2	41.1	5.8 W	8,800	7,020	1,780	25.3	4,840	4,520	320	7.1	0.305	0.258	0.047	18.2
B	M-2-A	44.9	7.0 W	8,100	7,020	1,080	15.4	4,720	4,450	270	6.1	0.275	0.260	0.015	5.8
	M-2	39.6	7.7 W	9,280	7,020	2,260	32.1	5,030	4,520	510	11.3	0.315	0.258	0.057	22.0
C	M-2-A	38.3	3.8 E	8,330	7,020	1,310	18.6	5,030	4,450	580	13.0	0.305	0.260	0.045	17.3
	M-2	39.6	2.8 E	9,350	7,020	2,330	33.1	5,550	4,520	1,030	22.8	0.315	0.258	0.057	22.0
D	M-2-A	42.1	2.3 E	8,270	7,020	1,250	17.8	5,420	4,450	970	21.8	0.300	0.260	0.040	15.4
	M-2	41.1	2.0 E	9,760	7,020	2,740	39.0	5,940	4,520	1,420	31.4	0.345	0.258	0.087	33.6

Values for extensometer given in lb. per sq. in. Values for deflectometer given in inches.

TABLE II—DATA FOR COMPARISONS BETWEEN CLASS S-2 AND S-3 LOCOMOTIVES

Class	Speed, m. p. h.	C. B.	Extensometer No. 11				Extensometer No. 12				Deflectometer				
			M	S	E	Per cent E	M	S	E	Per cent E	M	S	E	Per cent E	
A	S-2	68.2	3.8 W	6,600	4,820	1,840	38.2	5,940	3,805	2,135	56.0	0.255	0.195	0.060	30.7
	S-3	68.2	3.7 W	6,300	5,120	1,180	23.0	5,030	4,260	770	18.1	0.260	0.205	0.055	26.8
B	S-2	66.9	1.5 W	6,600	4,820	1,840	38.2	5,160	3,805	1,355	35.5	0.245	0.195	0.050	25.6
	S-3	68.2	1.6 W	6,600	5,120	1,540	30.0	4,900	4,260	640	15.1	0.250	0.205	0.045	22.0
C	S-2	66.9	7.0 E	5,830	4,820	1,010	21.0	4,520	3,805	715	18.8	0.275	0.195	0.080	41.0
	S-3	66.9	6.7 E	5,950	5,120	830	16.2	4,900	4,260	640	15.1	0.260	0.205	0.055	26.8
D	S-2	66.9	9.2 W	6,600	4,820	1,840	38.2	5,290	3,805	1,485	39.0	0.260	0.195	0.065	33.3
	S-3	68.2	9.3 W	6,600	5,120	1,540	30.0	5,420	4,260	1,160	27.3	0.275	0.205	0.070	34.1

Values for extensometer given in lb. per sq. in. Values for deflectometer given in inches.

of the north girder supporting the center track. Extensometer No. 11 was placed on the north edge of the flange, and Extensometer No. 12 was placed on the south edge of the flange. The deflectometer was placed at the center point of the top flange of the girder.

RESULTS OF TESTS

*Locomotives M-2-A and M-2.* Four test runs were obtained from each locomotive from which comparisons can be made. The data from these runs are given in Table I. This table shows that the maximum stresses, deflection and impact are less for the M-2-A locomotive than for the M-2 locomotive notwithstanding the fact that the static values are equal. This, of course, is due to the light reciprocating parts of the M-2-A engine. The maximum impact obtained for the M-2-A engine during the tests was about 22 per cent and for the M-2 engine, 35 per cent. In both cases the speed was about 40 m. p. h.

*Locomotives S-3 and S-2.* Four test runs were obtained from each locomotive from which comparisons can be made. The data for these runs are shown in Table II. Engine S-3 has a greater static value than engine S-2, but notwithstanding this the maximum stresses and deflections shown are practically equal in all cases, indicating that, regardless of the difference in static value or the weight on drivers, the engines have the same effect on the track.\* This is due to the lighter reciprocating parts on the S-3 engine. Test runs at speeds exceeding 75 m. p. h. were made with both loco-

motives. In addition to the above report on impact tests, attention should be called to the very thorough investigation made of this subject by the American Railway Engineering Association which was published in its Bulletin No. 125 in 1911. This report includes an account of tests made with two Burlington Atlantic type locomotives, one of which was a balanced compound having a weight of 51,000 lb. on the main driving axle. This engine was tested on a Pratt truss, pin connected single track bridge of 132 ft. span and a maximum percentage deflection of 15 per cent was obtained at a speed of 46 m. p. h. at the center of the span. At 58 m. p. h. the maximum speed at which this engine was run, the percentage deflection was 14 per cent. For comparison a test was run on a single expansion engine of the same type, having a weight of 46,500 lb. on the main driving axle, over the same bridge. This engine showed a maximum percentage deflection at the middle of the span of 26 per cent at a speed of 52 m. p. h., which was but 2 m. p. h. less than the maximum speed made by that engine during the tests. It will be understood that a legitimate comparison cannot be made between these tests and those relating to the Pacific type engine described above, due to the vast difference in the length of the spans of the two bridges, and to the difference in weight of the locomotives.

OTHER TESTS

ing parts allows the addition of considerable weight on the drivers over that used in a locomotive with ordinary steel moving parts without increasing the total effect of the locomotive on bridges and track.

\*The fact should not be overlooked, in this comparison, that the two locomotives have driving wheels of different diameter.—Ed.

# RAILWAY STOREKEEPERS' CONVENTION

A Digest of Reports Which Include Accounting,  
Reclamation and Handling of Company Material

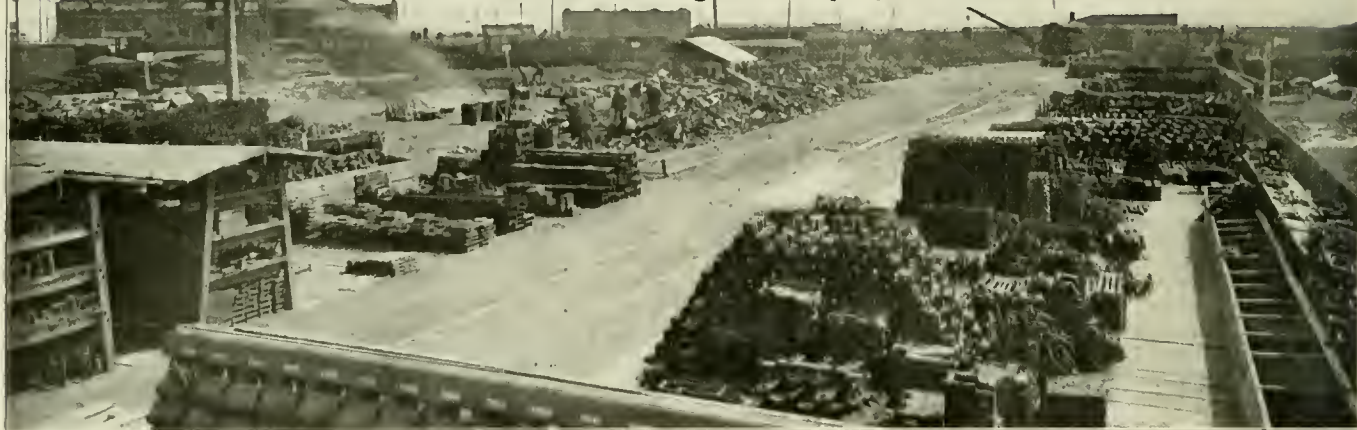

Reclamation Yard, Seaboard Air Line, Portsmouth, Va.

THE thirteenth annual convention of the Railway Storekeepers' Association was held at the Hotel Statler, Detroit, Mich., May 15, 16, 17, President J. G. Stuart, general storekeeper of the Burlington, presiding.

The invocation was offered by Rev. C. B. Emerson, after which the association was welcomed to the city by Hon. Oscar B. Marx, mayor of Detroit.

In his opening address President Stuart emphasized the continued need of economy. Material should be used to the very best advantage, as the railroads are now confronted with industrial conditions differing from any previously experienced. The manufacturers are doing their best to meet the demand for material, but the demand greatly exceeds the supply, so that special efforts must be made to obtain the best possible service from material now on hand and that which is received.

The work of the storekeeper is continually broadening and in selecting a man for promotion he should not be chosen simply because he has filled a certain position, but because he has filled it in such a way as to impress his superiors with his ability to handle something larger. The storekeeper should get around and familiarize himself with conditions and needs in the various departments, and study the conditions under which the work is done, so that he will realize fully the need or the lack of need of material that is ordered. Attendance at the conventions and participation in the discussion can aid greatly in helping the storekeeper to give what is demanded of him—service.

The secretary-treasurer reported a cash balance of \$171.80, and an active membership of 791.

## PIECE WORK

There was no committee report on piece work, but several members gave the results of their experience. D. C. Curtis of the Burlington stated that care should be taken to get the prices right in starting. There should be no mystery made of it with the men; under these conditions a piece work system will hold laborers with less shifting than day work. Do not try to change prices unless conditions are changed. J. H. Waterman of the Burlington gave it as his opinion that prices should be made so carefully at starting that there will be no need to readjust downward, which frequently causes dissatisfaction among the men.

It has been found on the Rock Island that piece work laborers stay longer with the company than do men employed at a day rate. This road pays its foremen an hourly bonus

for work done during the time a gang is working on piece work.

## ACCOUNTING

The accounting committee made the following recommendations:

That detail accounting be done by storekeepers at storehouses where the material is actually disbursed, and original requisitions be retained by them, except at outlying points under jurisdiction of employees of other departments, or where issues are so small that it is unquestionably desirable for accounting in connection therewith to be done at the division store controlling the territory, or at some other central store.

That storekeepers, where accounting is done, make distribution by values to primary operating accounts, operating divisions, main and branch lines, states, etc., and render necessary reports covering this and other accounting functions direct to auditing departments or thereto through higher store department consolidation offices, at the option of the carrier.

That as this association, in its convention at St. Louis in 1910, recommended basing the comparison of efficiency of operations on the unit of stock on hand and disbursements for actual use or other final disposition, reports of such operations shall be segregated according to the material classification adopted by this association, so that in such reports the materials or classes handled by the store department of each road will stand out clearly and can thus be compared intelligently with any other road in classified form. Thus any groups not handled by one road would be omitted and we would not endeavor to compare one property with another as regards materials which are handled by the one road which are foreign to the store department jurisdiction of another.

That by reason of the present requirements of the Interstate Commerce Commission, all stocks of frog and switch material along the line shall be carried in stock and charged out on semi-monthly or monthly reports from the track department as to actual applications, such material to be included in the regular inventories and any discrepancies not previously discovered adjusted in connection therewith.

That stock records be maintained covering such material and monthly checks made to see that all applications are reported.

That material provided for A. F. E. work be carried in

stock and charged to the work on reports from those in charge of actual use; such reports to consist of diaries at completion of small jobs (done in two weeks to thirty days) and semi-monthly or monthly diaries covering material used on large jobs.

That charges as made show price, point of origin, and actual weight of each item.

That an inventory of contract oils and greases be taken the first of each contract adjustment period at all points where such are issued for use and a statement prepared showing the quantities on hand from preceding reports; receipts during the period; total to account for; issued; en route; and balance on hand at end of period, the latter being represented by an actual check.

The difference between the amount on hand by inventory and the amount on hand by total to account for less issues, to be adjusted over the issues, on a pro rata basis. These reports to be substantiated by oil requisitions covering issues and receipted shipping notices covering receipts. The reports after being checked, to be consolidated for the entire railroad and one adjustment made on the consolidated report. Report of the oils and greases issued to be made by classes of service to the oil company at the end of each period. The oils and greases used for breaking in locomotives, and for the initial packing of boxes, to be included in issues.

A tentative schedule of bases for second-hand prices was submitted to the convention and will also be submitted to the Association of American Railway Accounting Officers.

The report is signed by H. C. Stevens, H. H. Laughton, D. R. Elmore, C. A. Miller, W. E. Brady and W. L. Hunker.

*Discussion.*—Several members did not agree with the percentages given by the committee. The report was referred back to the committee with instructions to substitute for the list given, a price for second-hand material of 100 per cent of the new cost, less the cost of repairs, except on certain specified items. The report was changed to conform with these instructions.

#### MARKING OF COUPLERS AND PARTS

The committee on the Marking of Couplers and Parts presented a progress report. The committee has been in communication with the manufacturers, and many items included in the 1915 report have been eliminated due to obsolescence. The members feel that all manufacturers should use the numbers recommended by the committee.

#### SCRAP AND SCRAP CLASSIFICATION

A number of inquiries were made as to the disposition of scrap glass. The result of the committee's investigation developed that there is a market for scrap glass and it can be disposed of in accordance with Item 85A—R. S. A. standard scrap classification. This glass must be clean in every respect; if any colored or dirty glass is mixed with the clear glass, the purchaser will not accept it.

If a carload lot can be accumulated from time to time it can be disposed of at any glass works. All of this glass is sold f. o. b. works and will net from \$2.50 to \$3.50 per ton.

In large cities there are generally one or more scrap dealers who will take glass, delivered in small lots, netting about \$1.00 to \$2.00 per ton, according to the market price.

It is the opinion of the committee that close supervision should be given to the handling of glass, and that it should be disposed of under rigid specifications in order that a loss will not result.

Scrap paper, such as accumulated by railroads, is worth from \$7.00 to \$10.00 per ton disposed of to scrap dealers, etc., in cities where it is accumulated.

By the proper supervision in handling of scrap paper a considerable saving can be made. In large cities a contract can be made with some dealer to furnish sacks, and a place set aside so that all paper from offices can be accumulated and put in the sacks belonging to the dealer. The dealer comes at intervals for the paper accumulated, leaving empty sacks to take care of further accumulation.

There is on the market a baling press for scrap paper which could be located at some large outside freight house and agents could save all paper, then forward it to this point in local shipments by sacks. It could then be put in this press and baled from time to time. This press could be stationed in one corner of the freight house. It is absolutely fire proof, made of metal and compresses bales weighing from two to three hundred pounds. After bales are pressed they are easily disposed of.

Where railroads are operating supply cars it would not be necessary to install a press at the larger stations, as outlined above, but agents could accumulate paper and hold it until the supply cars arrive. One of these presses could be installed in the supply car which could compress the paper and as fast as bales are accumulated they could be disposed of to the market direct.

The report is signed by W. Davidson, F. D. Reed, W. A. Linn, LeRoy Cooley, C. C. Dibble, A. R. Dale and R. L. Morris.

*Discussion.*—The members were urged to adopt and use the association's scrap classification. Some roads are selling scrap electric lamps, but the economy is doubtful owing to the difficulty of collection.



J. G. Stuart, President,  
Railway Storekeepers' Association

#### FILING OF CORRESPONDENCE

BY W. C. HUNT

An ideal filing system where every letter and every record can always be found is often advertised, but it has not been our good fortune to come in contact with such a system and for an office where there is a large volume of work, we do not believe such a system has been invented. There are, of course, various plans in use and they all have good points, consequently this is a subject which can be discussed from various angles.

The more simple we make the filing method, the more easily it is understood, but to make even the simple plan work we must supplement it with competent clerks in the filing room and with the proper facilities. A filing system for a store department must have a wide scope, as not only correspondence regarding material and accounting must be handled, but a great many other subjects come within the boundaries of this department.

Most of our correspondence troubles, it seems to me, are due to lack of supervision and a realization by the people who handle it of its importance. We know how annoying it is to call for a file of correspondence or a record and after search has been made to be told "It cannot be found"; or on the other hand, to have another department call for a reply to one of its letters and have to tell them "Cannot locate—Please send copy." This means waste of valuable time, and in most cases I believe it will be found that the system is not so much at fault as is a lack of proper supervision.

Because we experience these difficulties does not necessarily mean that we ought to try a new plan or make a very radical change in our old one. To do this simply adds confusion and a further difficulty in locating papers after a little time has elapsed. You cannot always keep the same man in the filing room and changes are always occurring in the personnel of a large office. It is my belief, therefore, that any plan which has been given some thought in its original construction, with relation to the requirements of the department, will prove satisfactory, if it is given necessary supervision. We ought to analyze these troubles to see why they occur, teach the stenographers and others who handle correspondence the importance of placing proper filing references thereon, and to handle them promptly.

I would like to outline the method we have been using in the store department of the Atchison, Topeka & Santa Fe for a number of years. We have had our troubles but we did not discard the whole plan on account of the minor difficulties. We analyzed and corrected them as they came up, until we feel that the system now covers our requirements and we experience little trouble.

The method we are using is one which covers the entire store department of the railway, from the smallest division store to the largest general store, and the details pertain to our general store at Topeka, where we are receiving and sending on an average of 700 letters and telegrams per day, 225 invoices, 400 requisitions from the store and operating departments, to say nothing of all the mechanical departments' requisitions, various reports, etc.

Foremost, in any system, is the matter of supervision and we have provided this by having what we call a head filing clerk, who has three assistants, a mailing clerk, and under him also comes the office boy who distributes the correspondence to the different desks, etc., after it has passed over the chief clerk's desk. All incoming mail goes to this filing room, where it is opened, stamped and all correspondence pertaining thereto attached. All outgoing mail passes to this room for placing in envelopes and addressing, thus conserving the use of envelopes.

This method insures always having someone in the filing room who is familiar with the records and the method employed. The expense of maintaining this may seem large but it is small compared with the time lost under the old method of letting high priced clerks spend a great deal of their time looking for records.

Under our actual filing method, all subjects are arranged alphabetically and each subject is given a number. These subjects are sent, in printed book form, to all stores and we

have endeavored to cover each class of material, report and statement under its respective subject. We have found that we can cover practically all subjects in less than 600 numbers and under any subject where the amount of correspondence is voluminous we make a further separation, arranging such separation alphabetically.

As an example of how this plan is arranged under the alphabetical and numerical arrangement, file No. 1 is Abrasives, No. 2 Acids, No. 3 Air Brake, No. 14 Locomotive Parts, No. 21 Mechanical Lumber, No. 22 Bridge and Building Lumber, and so on, until we reach No. 584, Zinc. These subjects are also cross indexed, as under the alphabetical arrangement, the same class of material may properly appear under two different letters. To make this clear, we will take file No. 1, Abrasives; the subject covers a number of articles and under it ground emery will appear under the letter "E," file No. 1; Pumice Stone under the letter "P," file No. 1, and so on, until each class of material is covered. In addition to the printed book of these references which is sent to each store, a copy is furnished each stenographer, thus insuring all correspondence being carried under its original number and subject to its completion.

It would seem under the method outlined that some of the files would become exceedingly large, but as I have before stated, we get around this difficulty by arranging the file alphabetically under its respective number where the amount of correspondence warrants.

We have further divided this system into two parts, one which we call the "Open File" and the other the "Closed File." Under the first heading, we keep under the jurisdiction of the filing clerk all correspondence that is awaiting a reply or is not complete. In this way a systematic check can be kept on correspondence which is not closed and also a regular follow-up plan maintained.

Under the second heading we keep all correspondence which is closed and is of no further use, except as reference. This closed correspondence is also kept under its proper date order. We follow this plan further when incoming mail has been opened, stamped and files pertaining thereto attached; it is passed over the desk of the chief clerk for check and distribution. This enables the chief clerk to keep posted on everything that is going on, as the files are complete when they pass over his desk. At the same time the filing clerks can be held strictly accountable for all the records.

Under this plan, of course, no clerk is allowed to keep any files or closed records on his desk. They must all be sent to the file room to be placed either in the "Open" or "Closed" file.

To work this method it is necessary to have the proper facilities and these we have provided at our general stores by having a separate filing room. These rooms are arranged with shelving, cases, etc., to take care of our needs. Neatness is one of the essential points in any filing room and to instill this into the minds of the people who handle this work, we paint all shelving cases, etc., with white enamel and provide them with the other necessary facilities, such as proper filing boxes to take care of the letters, requisitions, invoices, reports, etc.



W. A. Summerhays, 1st. Vice-Pres.  
Railway Storekeepers' Association



J. P. Murphy, Sec.-Treas.  
Railway Storekeepers' Association

In this room we keep all duplicating machines for getting out circular letters, bulletins, etc.; also have a binding machine for binding reports, requisitions, invoices and other records. One thing which we attempt to do is to allow nothing to be tied into bundles. We bind everything we possibly can and properly stencil it. At the end of each year's business we bind all requisitions, invoices, etc. You cannot lose a requisition or an invoice in this manner and it can never get out of its proper place.

**STANDARDIZATION OF TINWARE**

W. F. Jones, New York Central, chairman of the committee on Standardization of Tinware, presented a final report stating that the standards of the association and those of the Master Mechanics' Association were now identical and that they would be found in the 1915 proceedings of the latter association. All roads were urged to take immediate steps to adopt these standards, as considerable savings can be realized because of the ability of the manufacturers to manufacture in large quantities and carry the various items in stock.

**RECLAMATION**

Reclamation has become one of the biggest words in store department work and the possibilities of enormous savings are becoming more apparent every day.

The storekeeper is the pioneer in this work, but on many roads the reclamation work has been started by him and turned over to the mechanical department for the reason that facilities were needed and by the argument that it would require a duplicate organization to do this work under the store department.

Before the storekeeper began this work, it was attempted in the shops, but was objected to for the following reasons:

First—The shops were organized to turn out power and could not break into their regular work.

Second—The cost of reclaiming with high priced mechanics would show no saving.

Third—Their supervision was given to turning out locomotives and cars, and this work must have first consideration.

Fourth—Reclamation without organization, and where considered secondary, without proper methods regarding costs and overhead, is expensive.

These arguments are admitted as true and are the strongest recommendation for a separate reclamation plant where the work can be efficiently handled, supervised, inspected, and costs given proper consideration. If the work is handled by the storekeeper, he will see that the material that is needed is reclaimed so as to prevent in every way possible the purchase of new material.

*Supervision.*—The handling of scrap on practically all roads is under the store department. Scrap is carried in the storekeeper's accounts and sales are made through him. The proper sorting and reclaiming, therefore, simply means the expanding of this work.

When sorting the scrap to classification for the purpose of obtaining the highest price, it is only necessary to have men who are acquainted with material to pick out the serviceable parts. The store department has men who are acquainted with material for all departments and are therefore valuable for this work.

Inasmuch as the store organization is provided with the necessary records, as regards the amount of material on hand and the amount used, it can be seen that there would be no money wasted in picking out material that was already in stock, surplus or more than needed, and instead of reclaiming useless material, will quickly turn this into money.

The store departments are already trained in the proper accounting and prices, and are placed in the position where they cannot reclaim material unless such work shows a profit.

The users of material would always rather have new than second-hand, but when this material is handled by the storekeeper he will see that second-hand material is used first and in this manner provide an outlet for all that can be reclaimed and used.

The final measurement of a store department is its purchases, and it is interested in the use and any abuse of material. If this work is handled under the store department, a large percentage of the work and the handling of reclaimed material can be done by the regular storehouse force and by laborers and handymen. It is necessary when this work is handled by the mechanical department to do a good deal of it with mechanics and, in fact, the shop crafts would demand this work if done in the shops. Railroads, therefore, make a serious mistake in not taking advantage of using cheap labor in this work.

*Handling and Sorting Scrap.*—No railroad should sell scrap unsorted. Someone must sort and classify it before it is used and large quantities of serviceable material can be reclaimed from almost any car of scrap that will pay for the sorting.

Many scrap docks have just grown and the costs of doing the work have not been carefully considered or kept. Where from two to six thousand tons of scrap is handled per month, as is the case on the average road, the saving of ten cents per ton is no small item. Every road should keep these costs accurately so that they can be compared with other roads which have facilities, cranes, etc., and be able to show the savings which can be made by having the proper tools and facilities for doing the work.

The following statement showing costs of handling scrap will be of interest. It will be noticed that the roads that have gantry or overhead cranes are able to handle scrap cheaper than those equipped with locomotive cranes. The committee felt that these figures would be of interest to those roads which desire better facilities, cranes, etc., and which desire figures that will show what can be done.

STATEMENT SHOWING COST OF HANDLING SCRAP

Road	Cost per ton, old method	Cost per ton, new method	Average tons handled monthly	Cranes with Magnet
A	\$0.40	\$0.20	2,880	1 Gantry
A	.42	.37	7,000	1 Locomotive Crane
B	.50	.16½	6,000	2 Gantry
C	.57	.44	6,000	2 Locomotive Cranes
D	.52	.38	3,000	1 Locomotive Crane
E	.50	.40	4,000	1 Locomotive Crane
F	.80	.60	2,500	2 Locomotive Cranes
G	1.25	.42	2,550	1 Locomotive Crane
H	....	.58½	2,000	2 Locomotive Cranes
I	....	.61	6,000	3 Locomotive Cranes
J	....	.24¾	9,500	2 Locomotive Cranes

Road "A" has two plants and one equipped with Gantry crane reduced the cost 20 cents per ton.

*Reclamation Plant.*—In order efficiently to handle scrap, to know exactly what is being spent and to have the necessary supervision and force, it is desirable to have one reclamation plant on the average road, if the geographical location will permit. Local reclamation many times is carried too far, as no cost account is kept of the work and it is not properly supervised or inspected.

Centralized plants only will justify machinery and organization and keep a force constantly employed. Where material can be reclaimed at point of origin in the shops, cheaper than at the reclamation plant, it should be done, but there is great danger of duplicating work at point of origin as the work is not under proper supervision, and there is a tendency to work high price men. This work is also of secondary importance to the shops and does not receive the proper attention as regards costs, etc.

In laying out the reclamation plant, it should be designed so that the work will be progressive—in other words, so that the scrap will move one way and the good material go at once

to racks conveniently located and the material for reclamation move toward the proper machine without rehandling.

Many reclamation plants have just grown and are subject to criticism on account of the extra rehandling. Future needs should be considered so that as the different machines are added the whole plant will work as a unit.

The committee presents the following list of tools which are needed on practically every railroad handling even a small amount of scrap. These tools are in use at all points which have been doing this work and will save the greatest amount of money for the investment:

	Cost
1—Alligator shears for general run of scrap—motor-driven.....	\$1,500
2—Vise, forge, emery wheels, small tools, for repairing jacks, drills, shovels, etc. ....	100
3—Brass magnetic separator—motor-driven.....	300
4—Small shears for rounds and bolts—motor-driven.....	450
5—Small hammer, shop made—air.....	100
6—Bolt cutter—motor-driven.....	780
7—Nut tapper—motor-driven.....	600
8—Spike straightener, shop made—air.....	100
9—Coil spring reclaiming plant.....	350
10—Re-babbiting journal bearing.....	250
11—Brakebeam repairing plant.....	400
12—General utility hammer—motor-driven.....	600
13—Acetylene cutter and welder.....	.....
14—Washer machine—motor-driven.....	2,000
15—Iron reclaiming rolls—motor-driven.....	9,400

The committee has investigated these prices and knows that the amount shown will provide a suitable tool for the work.

Several hundred dollars per month can be saved by picking out good bearings and relining them. Many journal bearings can be reclaimed by the use of a cheap patented boring machine, which can be purchased for less than \$200 and many roads are making good savings along these lines. While it is better to have a broaching machine with which to bore these out, large numbers can be relined with cheap facilities.

If brakebeam work is done at the plant, it is not necessary to transport beams to and from the shops, or have any extra handling of the scrap. A good furnace for heating and a plate for straightening is about all that is required. The work is such that good handy men can do a first-class job. No refitting is necessary as parts for each beam interchange.

Acetylene cutters and welders can be used for many purposes and, while a general plant is the best, cheap portable plants can make big savings in cutting up large trusses, etc., and in welding and building up many articles. Close attention must be given this work, as it is expensive and many roads are curtailing its use.

A good washer machine will save its cost in a few months. Cutting miscellaneous scrap and flues is severe work and a good strong machine should be secured, which can also make other specialties.

Iron reclaiming rolls are particularly desirable at this time on account of the high price of iron and poor delivery. Any road that has sufficient accumulation of scrap that will re-roll should not be without one. Any shortage of iron that a reroll will handle can be quickly placed in stock. It is particularly desirable to have these rolls near the reclamation plant to save all extra handlings of both the scrap and the output.

The first twelve tools can be placed in the most temporary kind of building, built from scrap lumber and sheet and practically every tool will save its cost in from 30 to 60 days.

Brakebeam repair shops and reclaiming rolls require supervision to handle them, but there is no reason when the first nine tools are installed along with such work as repairing track jacks, drills, rehandling shovels, remounting hose, re-babbiting bearings, why an organization will not be sufficiently large to have proper supervision and inspection to efficiently handle brakebeam work and rerolling.

The following lists are given as a guide to show what is being done on different roads, and what can be done with only a small investment, as outlined in the list of tools:

ROAD A		Average amount per month
Savings made by—		
1—Reclamation and sorting out car material.....		\$10,000.00
2—Reclamation and sorting out mechanical department.....		450.00
3—Reclamation and sorting out roadway material.....		800.00
4—Reclamation of bolts.....		400.00
5—Reclamation of nuts.....		50.00
6—Reclamation of shovels.....		2,700.00
7—Reclamation of springs.....		.....
8—Reclamation of track spikes.....	Included in Road Material	1,700.00
9—Reclamation of bar iron.....		.....
10—Reclamation of paper.....		4,000.00
11—Reclamation of brakebeams.....		.....
12—Reclamation of hose.....		100.00
13—Reclamation of washers.....		.....
		\$20,200.00

ROAD B		
1—Reclamation and sorting out car material.....		\$ 6,913.08
2—Reclamation and sorting out mechanical department material.....		2,328.66
3—Reclamation and sorting out roadway material.....		1,587.90
4—Reclamation of bolts.....		1,633.42
5—Reclamation of nuts.....		1,221.89
6—Reclamation of springs.....		577.49
7—Reclamation of bar iron.....		124.04
8—Reclamation of brakebeams.....		3,253.00
9—Reclamation of washers.....		17.64
10—Reclamation of wrought iron.....		3,717.32
11—Reclamation of hose fittings.....		3,130.02
12—Reclamation of waste.....		252.73
		\$24,758.03

The committee has the necessary data regarding costs of tools and savings which can be made, in case any storekeeper or railroad is figuring on general reclamation work where a large or complete plant is desired.

These would be divided into three groups, as follows:

*For Yard*—Large alligator shears, magnet crane, casting drop, skips or buckets for handling scrap.

*For Bolt Shops*—Shears, bolt headers, bolt threaders, hammers, nut tappers, washer punch.

*For Blacksmith Shop*—Large power hammer, small power hammer, forges, bulldozers, spring tester, punch, emery wheels, power saw, rolling mill, furnaces, fans or blowers.

*General*—Magnetic separators, cinder washers, re-babbiting bearings, tin shop, hose room for mounting steam and air hose, stripping machinery, sewing machine for repairing sacks where used.

The inspection of material is a very important item and unless this inspection is carefully made, the statement from other departments that the work is inferior will have its effect. It is, therefore, especially desirable and necessary that all items reclaimed be inspected in the most thorough manner.

Many times complaints are made that reclaimed material is not satisfactory, and often the blame is placed where it does not belong, as the reclaimed articles may be picked out of some car or repaired at local points. It would appear desirable to have knuckles, coupler parts and similar articles dipped in some cheap asphaltum mixture so that if correct, these difficulties could be remedied; even though material is first class, it will be made use of much quicker if it looks like new.

Managements of railroads have been fooled so many times by figures that do not represent facts that it is necessary that the proper accounting be instituted that will bear the most rigid scrutiny, and if necessary call on the auditors to check the work so that they may know and you may be assured that your management respects the figures which are furnished as being accurate in every detail and that they cover overhead and all other charges and are real savings.

Cost of reclaiming, which includes all costs, is the governing factor and must include all costs of handling actual costs of reclamation, interest on investments, and the item must be satisfactory after being turned out.

It has been found to be a good thing to arrange visits of master mechanics, shop foremen and heads of departments to reclamation plants so that all may observe the loss of having material find its way to the scrap, also be of service in suggesting new ideas.

Reports showing the labor, overhead, total cost and comparison as authorized in last year's report should be made



each month so that the management will be aware of the savings being made.

The report is signed by D. D. Cain, chairman; R. K. Graham, J. C. Kirk, A. L. Tucker, H. G. Cook and W. J. Deihl.

#### COMMITTEE ON LUMBER

*Inspection.*—So far as the committee is able to learn, it is the general practice to inspect lumber at destination, there being but few exceptions to this rule, among which are the Union Pacific, which inspects oak at the point of loading; the Gulf, Colorado & Santa Fe, the Pennsylvania Railroad and the Illinois Central.

The inspection of lumber when received should be made strictly in accordance with the grade ordered; such grade having been adopted by the manufacturers' or dealers' association, governing grades in the territory where the stock is purchased; it being assumed that the railway in making the purchases selects the grade to fit its specifications. In cases of special specifications not conforming to the grades governing the territory in which the purchases are made, the inspection should be in accordance with the railroad company's specifications or special grade.

*Disposition of Rejected Lumber.*—The question of disposition of rejected material was discussed very thoroughly at last year's meeting and it is the committee's understanding that a majority of the members were favorable to declining all compromises with shippers, so far as accepting rejected material at a discount. It is found that on such roads as have adopted this plan, a marked improvement is manifest in the quality and grade of shipments received; there being a marked decrease in the number of rejects, as compared with the past.

*Stacking Lumber.*—There is a great variation in practice as between the different railroads; and a most decided difference in methods as between the railroad and commercial lumber yards, especially with respect to set rules as regards uniformity in foundations, stripping, height of piles, and their general appearance and grouping of dimensions in proper order. There are few railroads having ideal lumber yards, as in most cases the lumber storage must be arranged to fit local conditions, such as ground space available, track layout, convenience of delivery to shops, switching facilities, etc. The most important factors necessary to the ideal lumber yard are ground space and tracks. It would not be practicable for all roads to adopt the same practice, therefore, the committee recommends for consideration the practice as now in effect on the Gulf, Colorado & Santa Fe, quoted from a report from that road follows:

"All stacks should be from two to three feet above ground, to allow free circulation of air, and should be pitched, the front end higher than the rear end, on a pitch of one inch per lineal foot; thus in piles of 16 ft. lumber, the front end would be 16 in. higher than the rear end. Each piece should be exactly over the piece underneath it, and from 1 in. to 1½ in. apart from pieces on each side, for say 4-in. lumber, and increasing this space up to 3 or 4 in. in lumber up to 12 in. Crown pieces should be the same as the balance of the stack in lumber and timber, 1 to 4 in. thick. In timber 6 in. thick and over, this plan would run the stack too high, and 1 to 2 in. strips of waste lumber can be used. These cross pieces should be put on every layer and about 4 ft. apart and the front piece should project ⅛ to ¼ in. over the ends to protect the stack from sun and rain. Cut strips of waste lumber 2 in. by 2 in. and then saw these 2 in. square across from corner to corner and each piece will make two pieces that will be satisfactory, or saw pieces 1 in. by 2 in. by 2 in. When the stack is complete, take one piece the same as the balance of the stack and lay it flat on the space between each tier. Some saw mills put an air space 12 in. wide in the center of the stack, which they call a flue; others do not do this. Probably this is a

matter that should be regulated by climatic conditions.

"Be sure that the center bearings of each stack are not lower than the end bearing. The lines should be straight to avoid sagging and the consequent accumulation and retention of dampness.

"Be sure that the cross pieces are exactly over each other, or crooked lumber will result. Do not use decayed or rotten lumber for cross pieces or foundations, as doing so will contaminate the good lumber."

*Economical Ordering of Lumber.*—It is recommended that storekeepers take up with the heads of the various departments having the making of requisitions the matter of specifying the exact widths or lengths in which lumber is to be applied. If this practice were followed out, it would result in a very material saving, as a great amount of lumber could be ordered in random widths and lengths, which can, as a rule, be purchased at a lower figure.

*Saving by Re-Sorting and Substituting.*—A representative of one of the large systems reports that the road which he represents has effected a considerable saving by re-sorting from lower grade lumber. One item amounted to \$4,200 during the past year, in sorting V. G. and clear stock from common grades.

*Saving Effected by Using Lower Grades.*—On two of the systems represented on the committee, a considerable saving has resulted in the adoption of a lower grade of poplar. This grade has been found to be equally as good for the service as the higher grade stock. It was formerly the practice to use first and second clear yellow poplar. These systems are now using sap clears, which can be purchased at an average of \$10 per thousand less than the grade formerly in use.

*Re-Sawing.*—A very large saving has been effected by re-sawing, the principal stock used in re-sawing being second-hand bridge lumber. The Burlington kept account of the operation of its machine and the saving effected has approximated \$6,000 per year for the past three years. There is not only a saving in the sawing of the second-hand material, but also in the re-sawing of new lumber into odd dimensions, which are not ordinarily carried in stock. The re-sawing done by the Burlington has been principally in connection with lumber used in construction of buildings, stock yard trestles, etc.

Several points should be taken into consideration before locating a re-sawing plant. Perhaps the most important is the amount of available material that may be obtained from old bridges, buildings, etc. Such a mill should also be located as near as possible to the bridge and building material yard in order that the working force may be worked in conjunction with the force that handles the material. Storage tracks should be located convenient to the plant for unloading the material and piling it prior to shipment. The sawmill best adapted to this purpose is known as the "pony" type and can be purchased from a number of manufacturers for about \$250. The saws should be 40 to 44 in. in diameter and have what is known as the inserted tooth. A 30 h.p. engine or motor will furnish the necessary power for such a mill providing the larger machines are not operated at the same time. The sawdust is used in ice houses and sent out to passenger stations for sweeping floors. The cost of handling and re-sawing timbers varies from \$3 to \$5 per thousand and much of it may be worth from three to five times that amount.

*Manufacture of Tie Plugs.*—Of the roads represented on the committee, the Burlington is the only one manufacturing tie plugs. It manufactures these at all of its principal plants. The machinery originally in use consisted of table gang saws. Material is made into slabs of the required thickness, double the length of the plug. These slabs are gained in the exact center at right angles to the length, then put through the saw and ripped in from four to six strips, producing eight to twelve plugs, according to the widths of the slabs. The plugs were separated by breaking at the gain, breaking at

that point shaping the point of the plug. This process was found not sufficiently rapid to produce the number of plugs required for the season's work. It therefore became necessary to devise different machinery, and the mechanical department constructed a machine by converting a boring and mortising machine for this purpose. This tool cuts and points the plug in one operation, and has a capacity of approximately 200 plugs per minute. The maximum production has thus far not exceeded 1,600,000 plugs per month, on account of lack of material. There are three of these machines in use at this time. The cost of the original machine, including converting and installing, was \$226.

The material used in the manufacture of the plugs is mill waste, sawed into squares of the required dimensions and in lengths from 3 ft. up. The shorter waste is manufactured by the old style process—that is, the gang saw.

*Reclaiming Material from Torn Down Cars.*—The proposition of reclaiming lumber from torn down cars has not been taken up to any great extent, with the exception of four of the roads represented on the committee. The Burlington has gone into this matter to a greater extent than any of the roads represented. While it has no detailed figures to show the exact saving, by estimating a thousand feet to each car, multiplied by the number of cars torn down during the past year, the most conservative estimate suggests a saving of between \$20,000 and \$25,000. It must be understood that, of the lumber reclaimed, every foot displaces an equal amount of new material. Very much of the roofing goes back in repairs for the same purpose. It is also used for coal doors, sheathing under metal roofs, lining repairs, etc. The lining is also used for sheathing under metal roofs.

The reclaimed siding is used for original purposes; also for making of end doors, and repairs to side doors. All lining and roofing which is not fit for purposes previously mentioned is used in the manufacture of coal doors. Flooring is used for repairs in kind; also for decking for hand and rubble cars, sidewalks, platforms and coal door battens. The sills that are reasonably sound are used for sill splices.

The report is signed by James Garrett, chairman; J. F. Ritter, W. H. Clifton, W. S. Morehead, W. H. Thorn, A. L. Tucker, E. S. Newton, C. H. Schneider, F. B. Ashley and A. H. Young.

DISCUSSION

Certain questions pertaining to changes in specifications were recommended to the incoming committee on recommended practices. The committee also suggested the elimination of the first three paragraphs of the report on lumber. This suggestion was approved.

OTHER BUSINESS

Reports were also presented on Rail, Ties, Buildings and Structures, Stationery and the Handling of Company Material, and a paper by J. W. Gerber on Dismantling Cars is published in the Car Department section of this issue.

The following officers were elected: President, W. A. Summerhays, Illinois Central; first vice-president, H. S. Burr, Erie; second vice-president, E. J. Roth, Chicago, Indianapolis & Louisville; third vice-president, J. N. Shaw, Delaware, Lackawanna & Western; treasurer, J. P. Murphy, New York Central.

*POWER HACK SAWS.*—The first power hack saw machine was put on the market about twenty-five years ago. During the past few years the range and capacity of these machines have been greatly extended. They are furnished with quick return stroke, relief action for back stroke, means for using the full length of the blade, angle chucks and other improvements that have made this humble machine tool of high efficiency and low operating cost. Blades of great durability are furnished at low cost.—*A. S. M. E. Journal.*

DETENTIONS FROM A NEW ANGLE

BY F. E. SELLMAN

When at the end of a month, the various divisions on a railroad compare their locomotive failures, the usual practice is to give the number of failures, number of minutes detention, locomotive mileage, number of detentions per ten thousand locomotive-miles and number of minutes detention per ten thousand locomotive-miles. This is unquestionably a good comparison, but does it go into the subject deeply enough? From the motive power point of view it covers the ground fully; furthermore, that is what we have been used to—and no further questions have been asked. Let us consider if it covers the ground fully.

Why do we go to the expense of investigating the locomotive failures and tabulating the results? Of course, "to prevent recurrences," is the simple answer. Then why do we try to prevent locomotive failures? The traveling public would complain and soon a railroad would have a reputation for delayed trains that would take years of endeavor to correct.

The matter then assumes this aspect: We must not delay passengers. The number of passengers on a delayed train then becomes a factor; yet it does not appear in the reports of comparison. A through express train, carrying a large number of passengers, 300, for instance, is detained 20 minutes. This means that the passengers have altogether lost 6,000 passenger minutes. On the other hand, a local on a branch line carrying 30 passengers, loses 20 minutes, which would mean 600 passenger minutes. For the railroad's reputation and good name it matters a great deal whether there are 30 dissatisfied passengers or 300. Yet on the monthly reports of comparison each would appear as one failure of 20 minutes duration, while the fundamental factor has been overlooked, i.e., the number of passengers-minutes detention is the indicator of the service rendered.

For example: Two divisions, A and B, having the same mileage and the same locomotive mileage, have six detentions aggregating 95 minutes. These divisions would compare exactly alike from the motive power department's standpoint; yet from the traffic and operating department's point of view, division B excels in service division A, in that it detained less passengers per 10,000 locomotive-miles.

	Division A	Division B
Number of failures .....	6	6
Minutes detention .....	95	95
Locomotive mileage .....	106,000	106,000
Failures per 10,000 locomotive-miles .....	0.172	0.172
Minutes per 10,000 locomotive-miles .....	8.95	8.95
Passenger minutes per 10,000 locomotive-miles.....	1.235	923

*SPEEDS AND FEEDS.*—The important questions of speed and feed in connection with machining operations have, during recent years, been carefully studied by many superintendents and foremen who formerly relied entirely on the judgment of the workmen, which was sometimes good and sometimes bad. Speeds and feeds are fixed in the planning department and are based on the power of the machine and character of the metal.—*A. S. M. E. Journal.*

*ACCIDENT PREVENTION.*—The prevention of industrial accidents has received wide attention in industrial establishments. In machine shops accident prevention is a relatively simple matter, but there are a few points of danger which have become generally appreciated, and all of the better types of machines are equipped with guards to cover gears, setscrews, flywheels and all moving parts not necessarily exposed. There are also certain sources of danger which exist in practically all manufacturing plants and the general rules to prevent accidents from slipping ladders, piles of castings, elevators, etc., are being applied.—*A. S. M. E. Journal.*

# Car Department

## TERMINAL CLEANING OF PASSENGER CARS\*

BY J. E. ROSS

Master Painter, New Orleans, Mobile & Chicago, Mobile, Ala.

Terminal cleaning of passenger cars is an operation of primary importance and a problem involving the attainment of maximum results in a limited time for the least expense, time being as important a consideration perhaps as any other factor. Cleaning of any kind is ineffectual if not done thoroughly, and a delusion in the matter of cost if the work is in any way injurious to the article cleaned. Thus the need is emphasized of a system based on thoroughness and backed by a knowledge of what is best for the articles to be cleaned.

The term "terminal cleaning," while conveying the impression of one operation, actually covers three; one of these, really more important to patrons than mere tidiness, is sanitation; the other operation and to the railroad company itself a most important one, is the preservation of the mediums used to preserve and beautify the interiors and exteriors of passenger cars. Thus we have three operations, cleaning, sanitation and preservation.

Efficiency in this important work is governed entirely by three factors, interlocking and indispensable one to the other: First: A suitable location and suitable equipment; Second, Organization; Third, a director who understands the nature of the surfaces to be cleaned and having some knowledge of hygiene and sanitation.

The cleaning yard should be located in an open space of suitable area connecting with or adjoining the storage yard for passenger cars easily accessible and having a hard level floor, preferably of screened cinders, with sufficient drainage to take care of storm water quickly. All tracks should be of sufficient capacity to accommodate trains of ordinary length. Each track should be served with water and compressed air openings sufficient to space two to a car, these openings to be located between the tracks and in receptacles below the freezing lines and fitted with suitable covers when not in use. Steam pressure connections should also be provided, and so located that all cars in the cleaning and storage yard can be heated when necessary to prevent freezing or when being made ready for service.

For the cleaning of seat cushions, carpets, aisle strips, etc., a rack should be provided, made in sections so as to be easily moved from place to place if necessary. In localities where severe weather conditions obtain for long periods, a suitable shed should be provided located at the most accessible point in order to perform this work without loss of time or increased cost. Granted these facilities, we will now proceed with the various operations and methods of actual cleaning.

To a greater or lesser extent there will be found a miscellaneous assortment of discarded newspapers, candy boxes, chewing gum wrappers, fruit peelings and what not, strewn about the car interiors and whether the loose dust and cinders are removed with a compressed air nozzle or by the vacuum method, this litter must be removed first. This is done by a man going through the train and gathering it up in a suitable receptacle. All removable equipment should now be

taken out, such as cuspidors, aisle strips, seat cushions and water coolers (if these are removable), all equipment being checked as removed and anything missing or in bad order reported. This leaves the interior practically stripped and ready for the air or suction cleaner. The writer favors the former as being quicker and it can be made as effective as the suction method by using a six-inch nozzle made of brass with an opening not over 1/16 in., as this furnishes sufficient volume without waste of pressure. A nozzle of the same design, but 12 in. wide, is used for carpets and aisle strips. The nozzle is passed over and around steam heat pipes, behind fender guards and around seat frames, the operator passing it over the plush seat backs with a firm pressure against the pile of the plush, around and behind window fixtures, pulling down each curtain and working both sides of the aisle and toward one end of the car. All windows should be open during this operation to allow the dust to escape. In performing this work the operator should be protected by a respirator made from a piece of sponge of close texture dampened and fastened over the mouth and nostrils, and a long dust coat buttoned up closely.

The window glass should now be cleaned. This is best done by rubbing the glass quickly with a small sponge or piece of waste dampened and dipped in powdered Tripoli; when nearly dry the glass is polished off with clean, dry waste. Parts of the glass not accessible to the hand on account of sash overlapping can be reached with a small mop having a thin flexible handle of hardwood and a cloth wrapped around the end.

This leaves the general car interior ready for wiping down which should be done with clean cotton waste of fine texture and long fibre, 1/4 lb. per car being sufficient for all wiping of interior and exterior, including the trucks. This waste should be impregnated with a non-drying oil, neutral and preferably of vegetable origin, by immersing the hands in the oil and wiping them with the waste, repeating as often as necessary until the waste is sufficiently impregnated to catch all the dust without leaving the surface noticeably greasy. In blowing out and wiping down it is not always necessary to remove seat cushions or to wipe headlinings, although in the case of the latter if gas or oil is used for lighting it must be done frequently to prevent accumulation of smoke grease, both objectionable in appearance and destructive to the finish. It will be found that varnished or enameled surfaces treated in this manner are free from all dust particles and will present a revived and fresh appearance, the life of the varnish being prolonged and the dual service of cleaning and preserving being carried out.

The floor is now mopped with a deodorizer-disinfectant solution, hoppers and urinals having been cleaned and disinfected in the meantime, which leaves the car interior clean and sanitary, the appearance being governed largely by the general condition of the interior finish.

Water coolers, cuspidors, hoppers and urinals in the meantime are receiving the attention necessary to secure cleanliness and sanitation. After removing the cuspidors from the car, the operator takes them to a large sink with trapped sewer connection, and dumps them into a metal receptacle having a perforated bottom so as to allow all

\*Awarded the Second Prize in the Car Terminal Competition.

liquid to waste off and hold the solids, which are later removed; they are then mopped out with a strong potash or alkali solution containing an abrasive, rinsed with a hose and after being replaced, a small quantity of a deodorizer-disinfectant solution is poured into them. The same operator cleans and disinfects the hoppers and urinals, using much the same methods and materials as used in cleaning the cuspidors.

All passenger cars for the cleaning of which the writer is responsible, are equipped with removable water coolers of a standard and interchangeable design. After being removed from the car they are emptied and examined and if in good order are taken to a steam pipe having an open pipe connection in a horizontal position and fitted with a globe valve. The cooler is hung on the pipe, which is long enough to support it, and a strong pressure of live steam is turned in and maintained about half a minute. This thoroughly cleans and sterilizes the cooler and insures sanitation. The coolers are then ready to be replaced, filled and iced, tongs being used to handle the ice. If a hose is used for filling, care should be exercised not to allow water which has stood in the hose for any length of time to enter the drinking water containers, especially if exposed to the sun, as it invariably gives the water a bad taste. Complaints are frequently made of bad water and in many instances they are traceable to improper cleaning of the containers or carelessness in filling. If the drinking water containers are stationary they should be emptied and flushed out thoroughly.

The aisle strips or carpet having been cleaned in the meantime should now be replaced, completing the interior and bringing our attention to the outside of the car body.

The same waste used to wipe the interior is again treated with oil renovator and used on the outside, wiping being superior to washing as a regular cleaning method, inasmuch as while removing dust and in a measure preserving the varnish it also tends to remove dead or oxidized varnish film from the surface.

There are two ways of reaching the upper parts of the car, both practical. One is by the aid of the old style coach ladder fended off from the car surface with a box-like fender at the top having the contact face covered with a padded cushion. The other is by the use of a portable scaffold or bench ten or twelve feet long, with two low wheels attached to the legs at one end and two handles formed by the braces projecting at the other end. It is constructed of the proper height to permit an ordinary sized man to reach the letter board and has one step brace below the platform to enable the operator to attend to the windows and window stretch without stooping. The advantage of this bench over the ladder is obvious as the operator can cover a long stretch, properly cleaning the windows at the same time without getting up and down so often. It also saves time and effort in moving the ladder. The bottom stretch is treated the same as the top which completes the car body.

If the train arrives in the cleaning yard during a rain storm or with the outside of the car bodies wet, the use of the car washer brush will be necessary. This should be either of the fountain variety or in connection with a water supply from a hose, and during periods of low temperature and bad weather conditions, outside cleaning may have to be omitted altogether. Cars just out of the shop should be flushed down with a gentle stream of water, a good long bristle washer being used to start all dust that will not move otherwise. This cleans a freshly varnished car without marking or scratching the varnish, and assists in hardening it.

The trucks are often neglected and seldom receive the attention they deserve. The condition of the main surfaces should determine the cleaning treatment. If the surfaces are rough and broken and otherwise in bad condition it is obviously a waste of time to try to wipe them. A quick

treatment with the hose assisted by an old car washer brush is usually sufficient for trucks in this condition and as good as any, but if the surfaces are bright and reasonably smooth a quick treatment with the air nozzle, followed by hand wiping, gives good results quickly. Still another method is to spray the trucks with a mixture of water and oil, which is done by spraying from a reservoir having two compartments, one filled with oil and the other with water and having two nozzles spraying simultaneously. The mixing takes place at the nozzles. This should be followed by a quick application of the air nozzle which dissipates and evaporates the water and leaves a fine film of oil, thus cleaning and preserving the enamel besides improving the appearance wonderfully at little expenditure of time and effort. This should complete the terminal cleaning, and by proper organization can be done at a very low cost per car.

On railroads where the shopping periods for passenger cars varies from 18 months to 2 years and longer, this treatment will not be sufficient, and at intervals of not more than six months the cars should be taken out of service and thoroughly cleaned. This should include washing down and renovating of interiors and the cleaning of the exteriors with a neutral oil emulsion cleaner. If the cleaner is followed by the application and rubbing off of a good renovator, surprising results can be obtained, but this is optional as the car should look well without this. At this time a little touching up here and there on irons, pipes, etc., more than compensates for the time and material used in improved appearance. Acids and alkali solutions and emulsions are best avoided in terminal cleaning, as they are at best dangerous, and while they clean they also destroy to a greater or lesser extent, depending on the operator and how they are used.

## HOW TO KEEP CAR INSPECTORS

BY A. C. SHINAVER

Judging from the different articles published in the *Railway Mechanical Engineer*, there seem to be ideas on how to make good car inspectors but no clear or defined idea on how to keep them. My opinion, and I think the opinion of many others that have worked as car inspectors or around freight or passenger cars, is that if the following suggestions were tried there would be less trouble in securing and retaining a sufficient number of reliable inspectors:

Let the head of the car department look into the actual conditions under which their inspectors have to work in the different yards. I have found in my experience that no two yards are handled alike.

Have a sufficient number of the proper kind of tools.

Have one person who will give the inspectors *all* instructions, instead of half a dozen or more telling them what to do.

Show appreciation when good work is done. When an inspector makes a mistake do not say, "Why didn't you do it *this way*?"; but caution him to be more careful in the future.

Have a school for inspectors and give them instructions in the interchange, safety appliance and loading rules. Have the men get together and be more sociable.

Shorten the working hours and make three shifts in the 24 hours and pay better wages. It would be impossible to work for any less than inspectors are getting now and live. It is well known that the inspectors are not getting paid in proportion to what men get in the other departments, considering what they have to learn.

COOLING LUBRICANTS.—An improvement in shop practice worthy of mention is the more generous use of cooling mediums on cutting tools, and the provision of distribution systems for both the tools and the bearings supplied from a central reservoir.—*A. S. M. E. Journal*.



The Air Brake Association at Atlanta, Ga.

THE twenty-third annual convention of the Air Brake Association was held in the Ansley Hotel, Atlanta, Ga., May 2-5, 1916, J. T. Slattery, superintendent of the Denver & Rio Grande presiding. The convention was welcomed to the city by J. G. Woodward, the mayor of Atlanta.

#### PRESIDENT'S ADDRESS

The president called particular attention to the need of better air brake maintenance. He believed that railway officers were taking more interest in air brake questions but it seems that the money to be spent for maintenance of air brakes is still grudgingly given. The importance of the air brake in safely conducting the transportation business would seem to warrant a more liberal expenditure of money for its maintenance. The eastern roads should give more attention to the retaining valve pipe and associated parts. Usually these parts, which are of no service to the eastern roads, are neglected, and when the car arrives on the western mountainous road, repairs must be made before it is fit for grade work, causing serious delay to traffic.

#### SLACK ACTION IN LONG PASSENGER TRAINS

Troubles incident to operating long passenger trains have increased in the past few years, notwithstanding the consideration that the subject of passenger train handling has been given by the air brake men and others. Slack action in any train is produced only by a change in speed between the various cars comprising such trains. The degree or severity of such slack action depends on the rate at which the change in speed takes place, and the weight and number of cars involved.

Brake cylinder pressure must rise gradually in order that the movement in the train will be taken care of gradually, unless the speed be very high. Under the present order of general passenger brake conditions, this must be brought about by the brake pipe reduction being made in light steps and an increase in the time of making stops. The amount of the initial and succeeding brake pipe reductions, producing brake applications, must therefore be made in proportion to the speed of the train and the number of cars involved. It is necessary to maintain a brake cylinder volume equal to 8 in. piston travel on cars, if it is desired to obtain proper brake

cylinder pressure, and at the proper rate that the operating mechanism was designed for. Piston travel shorter than 8 in. produces a higher cylinder pressure for any given brake pipe reduction than should be the case; therefore this reduces the time in which the cylinder pressure can be built up, causing the cars to stop more suddenly than desired. It is the opinion of the committee that some means will have to be provided to offset the bad effects of heavy cars and single shoe type of foundation brake gear. The automatic slack adjuster cannot be eliminated, since it is impractical to attempt manual adjustment of piston travel on passenger cars generally, on account of wide variations in the matter of time, difference between standing and running travel, the inability to determine these differences and the liability of excessive travel.

Therefore it can be seen that although a train may be equipped throughout with PM or LN equipment, many faults exist in which the type of triple valve has no bearing. The manner in which experience has demonstrated the responsibility of the triple valve in relation to slack action in passenger trains, is that in connection with mixed PM and LN equipments, where the graduated release of the L triple valves are being used in connection with cars in the same train equipped with P triple valves. The L triple valve, if a reduction of brake pipe pressure is made after a partial release, develops a higher brake cylinder pressure in proportion to the brake pipe reduction than is the case with the P triple valves. This feature of the L valve produces a high rate of brake cylinder pressure increase which may produce slack action in trains.

There are four causes contributing to poor train handling, but no attempt will be made to cover them more than fully enough for those broadly informed on the subject to follow cause and effect.

*Weight of Vehicle.*—This necessarily involves magnitude of braking forces, which in turn means large brake cylinders, which require: Large air volumes; large air valves, and heavy foundation brake gear.

*Length of Trains.*—This introduces a serious element into brake operation and performance, namely, that of time, particularly that of difference in time between brake application on the vehicles at the front of the train and those at the rear, permitting retardation to commence at the front of the train long before it commences at the rear, thus bunching the train and producing a reaction when an equivalent re-

tardation from brake action ultimately takes place at the rear.

*Foundation Brake Gear.*—On account of the heavy forces and consequent severe duties imposed on the foundation brake gear, the designs generally used have become entirely inadequate as far as efficiency in permitting the air brake itself to perform its functions in proper proportion and the smooth handling of trains are concerned. The faults in the present foundation brake gear are principally in the spring suspension of hangers, the shoes being hung very low on the wheel, and the use of the "single shoe" type of gear. This design and type of foundation brake gear necessarily involves the condition of very short piston travel, which even with very light reductions results in a complete annulment of the proportions of the air brake proper, which results in very heavy braking forces, even when the lightest is necessary to avoid shock. In the endeavor to avoid this shock on the part of the engineer by making very light reductions, so little differential in pressure is produced between brake pipe and auxiliary reservoir that some of the brakes will fail to release with the consequent loss of power, inability to make schedule time, increase in fuel consumption, burning up of brake shoes and heads, and flat wheels.

*Air Brake Valve Mechanism Itself.*—When length and weight of trains was much less than at present (remember that many cars in trains of today now require two complete brakes per car) the attainment of a comparatively great and rapid differential or change of pressure was easily secured, but under present conditions this necessary condition is not possible with the equipment as now used.

This report has dealt only with the fundamental causes of the bad effects, and the remedies suggested strike at the root of the evil. It may be presumed, however, that the bad effects may be mitigated in a practical manner by instruction, maintenance and manipulation.

The report is signed by J. A. Burke, chairman, and W. Hotzfield.

DISCUSSION

The foundation gear on many of the modern heavy cars was believed to be of improper design. Those roads that are using the clasp brake do not have nearly the amount of trouble that is experienced by those roads using the single shoe brake. The violent shocks in passenger trains which are many times sufficient to break a passenger train in two are the direct result of uneven piston travel in the cars throughout the train. This is due to an efficient foundation gear and poor brake cylinder maintenance. It was stated that the locomotive engineer could not be held responsible for poor handling of the train when such conditions exist. With the single shoe type of gear the shoes are hung below the horizontal center line of the wheels and as they are pulled down by the friction of the wheel, in heavy brake applications, the automatic slack adjuster compensates for this additional horizontal movement of the shoes and thereby shortens the piston travel which gives unequal braking. For this reason the clasp type of brake was strongly recommended. With this type the shoes are hung on the horizontal center line of the wheels and the pressure of each individual shoe on the wheel may be reduced. The forces acting on the truck are also such as to tend to keep the shoes in their proper position. With conditions such as they are at the present

time it is believed necessary to take longer time in stopping the long passenger trains than is necessary in stopping the short trains by a more gradual application of the brakes. The subject was continued for the purpose of investigating means for overcoming the difficulties now met in train operation with the present air brake systems.

MAINTENANCE OF FREIGHT BRAKES

To maintain higher efficiency of freight brakes, regular and systematic inspection and repairs are necessary. There are no doubt thousands of brakes practically useless which reach the next cleaning date without their condition becoming known. Recent dates of cleaning, shown by stencils on many defective brakes found, indicate poor work done by cleaners. Brake cleaners cannot be criticized where adequate means for testing are not provided or where the men are not properly instructed in making brake tests and repairs or are not allowed sufficient time to do the work well. The error is often committed, in connection with air brake work, of requiring quantity and neglecting quality.

In 25 trains tested on account of complaints that they were hard to hold on heavy grades, it was shown by thermal tests made at the foot of a grade that from 10 to 26 brakes in each train were of no use. The test before leaving the summit consisted in a 20 lb. reduction being made and all brakes were considered good that remained applied while an inspection was being made (about 14 minutes). This indicated 28 to 49 tons per brake, while the thermal tests made after descending the grade showed 36 to 74 tons per good brake. The number of cars in these trains ran from 56 to 70 and the gross tonnage from 1,940 to 2,850 tons per train.

As an indication that the condition of freight brakes showing the need of more efficient cleaning and repairing is found throughout quite an extensive territory, we will give a few figures covering brake conditions on cars passing over a group of roads which maintain "deadlines" to protect their mountain grade traffic. One tabulation shows that out of 19,862 freight brakes, representing many different lines of railroad, that were tested during the last eight months of 1914, parts required repairs as follows:

Triple valves .....	2,268
Brake cylinder packing leathers.....	2,295
Pressure retaining valves and their pipes.....	3,080

By another tabulation made at "deadline" points covering 40,367 brakes tested during eleven months in the latter part of 1913 and the forepart of 1914, the parts shown to be defective were as follows:

Triple valves .....	5,386
Brake cylinder packing leathers.....	8,369
Brake cylinders cleaned, including those having packing leathers defective .....	17,813
Pressure retaining valves.....	10,046

The following tabulation covering triple valves removed and sent to repair shops when defects were indicated by yard and cleaners' tests and in cases of slid flat wheels, will give an idea of the kind of defects found in triple valves and the extent to which they exist.

15,270 triple valves removed for all causes.
8,638—56 per cent—Packing ring leaking.
5,444—36 per cent—Slide valve leaking.
1,871—12 per cent—Graduation valve leaking.
1,348—9 per cent—Piston hushing worn.



J. T. Slattery, President.  
Air Brake Association

1,244— 8 per cent—Emergency valve defective  
 156— 1 per cent—Feed groove defective.  
 274— 2 per cent—Vent valve defective.  
 350— 2.2 per cent—Vent valve piston.  
 196— 1 per cent—Water in triple.

The foregoing figures would indicate the necessity for more and better triple valve repairs and, in addition to this, the committee emphasizes the need of systematic and continued attention to brake cylinder leakage. It is indicated by careful tests made that approximately 50 per cent of freight brake inefficiency is due to brake cylinder leakage.

A large part of these brakes are considered efficient by level roads. This involves a number of details, such as packing leathers in poor condition on account of being porous, due to not being treated at regular intervals with a proper filling substance, worn thin or cracked, not being centrally applied on the piston, follower plate bolts not drawn tight, expander ring of poor quality of metal and lacking elasticity, failure to shape the expander ring to fit the cylinder



T. W. Dow, 1st Vice-Pres.  
Air Brake Association

and follower plates of too small diameter to prevent the expander ring slipping out of place.

As showing the effect of service, a gage test of 76 brakes that had run less than the allotted time since cleaning showed, after obtaining 50 lb. brake cylinder pressure and noting loss during one minute:

71.0 per cent leaked over 5 lb.  
 59.2 per cent leaked over 10 lb.  
 40.7 per cent leaked over 15 lb.  
 21.0 per cent leaked over 20 lb.

The 59.2 per cent that leaked over 10 lb. averaged 22 lb. leakage per minute, or 44 per cent of a full service application. Yet, all of these are brakes that would be termed "Efficient" in an ordinary terminal test.

A thorough instruction trip, during which work done by cleaners and repair men was carefully checked and advice given as to how to locate and remedy defects, produced a betterment in the following year of 7.5 per cent in the average months of service before cleaning was required.

The report was signed by: Mark Purcell (chairman), J. T. Slattery, and Frederick VonBergen.

DISCUSSION

The importance of maintaining the brake cylinder in good condition was greatly emphasized. Trouble has been experienced with the cylinder packing leathers becoming porous. Some roads are attempting to reclaim them by soaking them in a suitable "filler."

F. B. Farmer, Westinghouse Air Brake Company, referred to the brake cylinder as one of the most important and vital parts of the air brake system. Its cleaning, lubrication and repair are almost entirely placed in the hands of the lowest paid air brake man, and too often the quantity handled by this man is the sole measure of his work. The properly maintained triple valve must accompany the properly maintained brake cylinder. With the latter and without the former the brakes will creep on, resulting in stuck brakes and slid-flat wheels. The soap-suds leakage test on the brake cylinder piston rods is a simple, quick and reliable test which none should neglect to use.

On the Northern Pacific a brake cylinder is set up at repair points to enable the men working on air brake repairs to test out packing leathers and learn to distinguish between the good and bad ones. In the closing Mr. Purcell stated that a great deal of inefficient work is due to the lack of proper instruction or education of the man that is assigned to do this class of work. It is possible to maintain an air leakage of less than five pounds per minute by proper organization and competent workmen. The lubricant used in an air brake cylinder should be such as would penetrate into the packing leather serving as a filler.

AIR BRAKE APPRENTICES

BY C. M. DRENNEN

Few, if any, railroads have made any effort, until recently, to produce specially trained men to take care of the air brakes. Air brake mechanics are generally selected in locomotive service from machinists or in car service from car repairers or helpers. According to the schedules of most railways, machinist apprentices are given their choice of two or three months in either "the tool room, air room, or brass corner." This is usually the experience that a greater part of the air brake mechanics have during their apprenticeship. They are, therefore, not equipped to take the responsibility of air brake work in the roundhouse or shop, but must get their training by experience after becoming machinists. This is expensive, not only because of the pay the machinist draws but also because of the mistakes he will make and, therefore, the delays he will cause while he is getting this experience.

One railroad is training machinist apprentices for air brake work by giving them their last six months on air brake work with the two or three months they had in the air brake repair room. This will give them eight or nine months of practical experience. This road gives all machinist apprentices air brake class room instruction once a week for four to six months of the year. Classes are held at night in a room especially equipped and attendance is made compulsory. The

boys are started in these classes not later than the time they begin work in the air brake room. Another road gives six months in the air brake repair room, six months in roundhouse air brake running repairs and turns the technical training over to the International Correspondence School. An efficient air brake mechanic is one having such practical experience and working knowledge of air brakes that he can inspect, repair, set up and test properly the



C. H. Weaver, 2nd Vice-Pres.  
Air Brake Association

equipment in his charge in the least possible time.

Following are the proposed schedules for specializing apprentices on air brake work. In the first one the boy would be selected from the machinist apprentices as they go through the air brake repair room. They will have served two and a half years as machinist apprentices, and when they get in the air brake work, if they show themselves especially adapted for this work, they may be made air brake apprentices and given the following schedule with which to finish their time as such:

	Months.
Air brake repair room in general shops.....	8
Lubricators, injectors, and headlights.....	3
Air brake pipe work.....	1
Roundhouse air brake repairs, inspecting, etc.....	5
With road foreman of engines, air brake instruction car, or firing .....	1
Total .....	18

The schedules following will give an air brake apprenticeship from the start. The usual method of selecting apprentices would be followed; that is, from boys in the shop or applications. They should be given six months as others are, and if not fitted for the work could be transferred or dismissed:

	Months.
Repairing hose, angle and cutout cocks, retainers, etc. ....	3
Cleaning and repairing triple valves .....	6
Dress press and lathe work .....	3
Repairing pumps .....	3
Repairing brake valves and engine equipment .....	4
Lubricators, injectors, headlights .....	2
Air brake pipe work.....	2
Rip-track air brake work.....	1
Inspecting trains (helper).....	1
Roundhouse air brake works .....	9
With road foreman of engines, air brake instruction car and firing.....	1
Total .....	36

It may be said that there is not enough demand for air brake mechanics to afford a place for such an apprenticeship. Yet, if the number of men who are employed on railroads in the service of tinner, blacksmith, painter, upholsterer, patternmaker, molder, etc., for all of which an apprenticeship course is furnished, is compared with the number of men working on air brakes, lubricators, and injectors, it will be found that the latter will exceed any one and most any two of the former classes. The air brake is fully as important, requires as much skill, and certainly more time should be spent in learning how to take care of it.

A schedule for air brake apprentices for car work is given below:

	Months
Dismantling air brake equipment.....	1
Repairing hose, angle cocks, etc.....	2
General rip-track and air brake repair work.....	10
Cleaning and repairing triple valves.....	4
On brake cylinders.....	2
Leverage work .....	1
Testing .....	1
Inspecting trains .....	8
Braking on road.....	1
Total .....	30

This would make a trade out of air brake repairing and inspecting and would secure better men in the service; it would produce men that would be valuable assets to the car department. The efficient air brake mechanic will keep down failures, keep engines and cars moving, and add much to the life of air brake equipment. The value cannot be estimated, nor can the railroad determine the exact results from such an expenditure, but it will be repaid many times for the efficiency added to these departments.

DISCUSSION

It was stated that the importance of having an adequate and thorough apprentice system for the instruction of the men that maintain the air brakes has been greatly underestimated in the past. It is necessary for these men to thoroughly understand the purpose for which the various parts of the air brake equipment are used in order that they may know of the importance of their work in train operation. There is no question but that a lot of work is done inefficiently, and that delays and accidents occur because the men

handling the air brake repairs are not properly informed. It was believed that this subject was a most important matter for the railroads to consider.

CARE OF MODERN PASSENGER BRAKE EQUIPMENT

BY C. U. JOY

The subject of the care of modern passenger brake equipment naturally divides itself into three parts, namely: Inspection, yard testing, and maintenance.

*Inspection.*—Car inspectors, repairmen and air brake inspectors should be instructed and required to pass an examination on the construction and operation of the air brake equipment in order to qualify them properly to perform their duties. Trains should be properly inspected on arrival at terminals. Local trains should be given a terminal inspection once each day. The automatic slack adjuster is an essential part of a modern passenger brake equipment, and must be attached to each brake cylinder.

*Yard Testing.*—Every passenger train, after having had its terminal inspection, should be subjected to a proper yard test. The yards should be properly piped and have compressor capacity sufficient to maintain at least 110 lb. air pressure. There should be a portable testing machine with suitable walks between the tracks to facilitate moving it about. A terminal yard handling 16 trains, averaging 8 cars each per day, should have one testing machine and two men to make the tests.

*Maintenance.*—The subject of maintenance may, for convenience in handling, be divided into three parts: Valvular mechanism; parts connected with air, such as piping, brake cylinders and slack adjusters, and the mechanical transmission, such as levers, rods, brake shoes, etc.

It has been the practice of practically all railroads to clean the triple valve every three months and the brake cylinder and slack adjuster every six months. Tests have developed that a PC control valve properly cleaned and lubricated and afforded proper protection from dirt and moisture will remain in service over a year and stand the yard test each day, and also that this same valve will pass the rack test. Such being the case it is reasonable to assume that the efficiency of the valve is increased above what it would be if it were cleaned four times during the year or every three months. The control valves that were subjected to this test were lubricated as follows: The slide valves, piston bushings and packing rings were lubricated, sparingly, with dynamo oil, graphite and oil, triple valve oil and a light generator oil.

The cost of removing, cleaning, testing and replacing a control valve is, together with the dust collector and strainer, about \$1.53. All valvular mechanism that fails to pass the yard test should be removed and shopped for repairs.

All piping should be thoroughly inspected and tested. Tests have determined that if brake cylinders are properly cleaned and lubricated, particularly if they are equipped with the J. M. expander ring, they will remain in service with a minimum leakage for 18 months. The cost of cleaning and lubricating the brake cylinders and slack adjusters is about \$1.02, which, added to \$1.53 for the control valve,



F. M. Nellis, Sec.  
Air Brake Association



Otto Best, Treas.  
Air Brake Association



gives a total cost for cleaning the entire equipment of \$2.55, the average price of labor being 25½ cents per hour. Extending the time of cleaning of the control valve to six months and the brake cylinder and slack adjuster to 12 months would mean a saving of 50 per cent of the present cost of this work, and experience will probably demonstrate that a further saving may advantageously be made along these lines.

Lever and rods should be carefully inspected. The construction of the foundation brake gear should be such as to maintain the position of the brake shoe in relation to the wheel at the same point practically all the time, giving uniform braking and an even wear of the shoes.

With the heavy passenger equipment now in use a properly designed clasp brake is of the utmost importance for efficient and satisfactory braking. The advantage derived by using the clasp brake is very noticeable in service, as it does away with the pulling-down effect on the truck during a brake application, making a much smoother stop. Hot boxes are eliminated to a certain extent due to an equal pressure being exerted on each side of the wheel which holds the journal in its bearing and the tendency of picking up waste between the journal and bearing is remote. Tests have shown that with this type of brake the life of the brake shoes is approximately 30 per cent greater, due to the low brake shoe pressure.

DISCUSSION

It was generally believed that the time of cleaning triple valves, control valves and brake cylinders on passenger equipment could be increased from three to six months provided the work was thoroughly done by competent men. This does not mean, however, that they should not be tested. One member believed that it would be practicable to allow these parts of the air brake equipment to go without cleaning until they were shown defective by the M. C. B. tests. This would materially reduce the cost of the air brake maintenance. Some members advocated that no oil be used on a triple valve slide valve seat. Oil is a cause of undesired quick action and will catch dust and cause the valve to become dirty. Tests made on the Central of New Jersey with 1,000 new cars, on 500 of which the triple valves were lubricated with graphite and the other 500 having no lubrication at all, showed at the end of the year that those with no lubrication had given the better service and were in better condition.

MOISTURE IN LOCOMOTIVE BRAKE SYSTEM

BY MARK PURCELL

It is absolutely necessary thoroughly to thaw and blow out the main reservoirs and piping each trip before the engines leave the roundhouse. Where this practice has been followed, freezing of the pipes in severe cold weather has been eliminated, and where this has not been done the freezing has been frequent.

Temperature tests of the air were made on a locomotive having an 8½-in. cross compound compressor located on the left side, and well forward, two main reservoirs—one on each side under the running boards and well forward of firebox—with a combined capacity of 75,000 cu. in., 45 ft. of 1½-in. discharge pipe between the compressor and the first main reservoir located under running board on left side of engine and 50 ft. of 1-in. equalizing pipe between the first and second reservoirs running from the forward end of the first main reservoir on the left side, under boiler to the right side, then forward and back under the running board connecting to the forward end of the main reservoir on the right side of the engine, a 1-in. pipe extending from the back end of the second main reservoir to the engineer's brake valve. Thermometers were inserted in the piping at different points as follows: No. 1 at the point of connection of the compressor discharge pipe to the first main reservoir; No. 2 at

the connection of the 1-in. equalizing pipe to the second main reservoir, and No. 3 in the 1-in. pipe between the second main reservoir and the engineer's brake valve. Other thermometers were used to determine the prevailing temperature of the air before it entered the compressor. The locomotive was standing still during the tests and there was a slight wind blowing against the right side of the engine.

The compressor was started and when the pressure had been raised from atmospheric to 90 lb., as shown by the air gages, thermometer No. 1 showed 80 deg.; No. 2, 41 deg., and No. 3, 44 deg. The engineer's brake valve was then placed in full release and the rear angle cock opened sufficiently to relieve the pressure, and the compressor was run for 2 hours and 45 minutes with results shown in the following table:

No. of Run	Time run—min.	Speed single strokes per min.	Temperature degrees—F.			Air pressure pounds		
			Atmos.*	At strain-ers†	Ther. No. 1		Ther. No. 2	Ther. No. 3
1	27	128	40	60	121	61	63	90
2	25	108	40	60	116	56	62	90
3	15	120	40	60	136	66	60	88
4	25	120	45	63	146	81	68	85
5	20	122	45	63	146	83	63	90
6	28	80	45	60	106	61	60	90
7	25	80	45	58	106	60	60	90

\*Thermometer was located 15 ft. from the engine on the right side.

†Thermometer was located 10 in. from the strainer of the compressor.

As shown in the table, thermometer No. 3 showed a slightly higher temperature than thermometer No. 2 in the first and second runs and lower in the subsequent runs. This was due to the effects of heat from the firebox and variation in the speed of the prevailing wind. The difference in temperature of the surrounding atmosphere and that at the compressor air strainers indicates the necessity of locating strainers in the coolest place possible. Conditions observed generally as well as the temperatures shown by the tests would indicate that the proper amount of cooling pipe needed has not been reached in any of the locomotive installations yet recorded.

There should be at least two main reservoirs on each locomotive with 50,000 to 90,000 cu. in. total storage volume, corresponding to compressor capacity, and preferably not less than 60,000 cu. in. for freight locomotives, with 45 ft. of discharge pipe between each compressor and the first main reservoir, and from 50 to 60 ft. of equalizing pipe between reservoirs. One inch pipe is preferable to any larger size for the equalizing pipe between reservoirs on account of it giving a greater amount of radiation per cu. ft. of air passing through it and providing sufficiently rapid flow to fill the requirements when releasing the brakes. Air cooling pipes should be located above the point of connection to the reservoirs so that moisture may drain into the reservoirs with the flow of air.

DISCUSSION

It was stated that it was impossible to lay down a hard and fast rule governing the length of radiating pipe between the air compressor and the main reservoir. The length of radiating pipes depends upon the size of the compressor. Mr. Park, of the Westinghouse Air Brake Company, stated that ½ sq. ft. of radiating surface is allowed per cu. ft. displacement of the compressor in communities where it is neither too warm nor too cold. The pipe passing from one side of the engine to the other is not included with the radiating surface, as it is too near the boiler. Also the surface of the reservoir is not included in computing the radiating surface. The air strainer to the pump can, with considerable advantage, be piped out from the pump to permit of getting as cool and dry air as possible.

Mr. Purcell stated that on the Northern Pacific 88 sq. ft. of radiating surface is used per 100 cu. ft. of free air displacement of the compressor, and one-third of the surface of

the main reservoir was included in the radiating surface, although he believed this was excessive.

### EXCESS PRESSURE

BY M. S. BELK

Excess pressure is generally understood to mean the difference between the pressure in the main reservoir and that in the brake pipe. Since my connection with air brake work, 20 lb. excess pressure has been considered the proper amount to carry on all classes of trains. In the past few years we have made many changes in the air brake equipment, necessitated by increased weight of cars and locomotives and the great increase in the number of cars hauled. There are times when we need a higher excess pressure when the brake valve should be allowed to remain in running position. When ascending long grades, we always have quite an increase in brake pipe leakage. In addition to this, the compressor is called upon to furnish then more air than at any other time for sanders, fire doors and sometimes the bell ringers. Should we be unable to maintain the proper excess, does not the feed-valve commence to close? If so, do not the brakes commence to creep on? This very often necessitates "doubling."

We were not in a position to materially increase the compressor capacity immediately and it was up to the "air-man" to do something. So, in our efforts to overcome the trouble, we increased our excess from 20 to 30 lb. with excellent results.

### DISCUSSION

It was stated by several members that if the feed valves and their connections were kept in proper condition, and the leaks in the train line brought down to the proper amount there would be no necessity for carrying more than 20 lb. excess pressure in the main reservoir. Some members recommended that the feed valve be tested every two weeks, and one member stated that every week was plenty long enough for them to run. An imperfectly maintained feed valve is responsible for the brakes creeping on and for stuck brakes. It was also stated that the need of excess pressure was due to insufficient capacity of the compressor. On the long trains carrying an excess pressure greater than 20 lb. the pump is liable to run hot. On the Santa Fe soap-suds tests are applied to the hose, and tests for leakage are made to every car sent to the repair tracks, whether it is sent for air brake repairs or not.

### RECOMMENDED PRACTICE

Under heading "Gages," sub-heading "Location," the following articles should be added: (4) All cabooses should be equipped with an air gage. (5) Caboose gage should be lighted with a lamp arranged with suitable shades that will permit the light to show only on the face of the gage. (6) Gage location to be such as to permit of readily noting the pressure either from the cupola or the conductor's desk. (7) Caboose gage should be of good quality and the dial should be not less than 5 in. in size. (8) The ¼-in. pipe to air gage to be provided with a tee head cut-out cock and between cut-out cock and gage a plug tee to be provided for use in carrying on necessary tests with caboose gage.

Under heading "Triple Valves," sub-heading "Cleaning and Repairing," the following article to be added: (10) In cleaning emergency valve seats no sharp instrument should be used that would possibly scratch or mar it. All flat seats should be re-machined to the standard half-round bearing.

Under heading "Piping," sub-heading "General," Article 2 to be changed to read: All pipes should be hammered and thoroughly blown out before being connected and all pipe ends to be reamed full size after cutting.

Under heading "Foundation Brake Gear," sub-heading "Leverage," Article 11 to be changed to read: Foundation brake gear on all modern passenger equipment cars should

be designed so as to withstand 105 lb. cylinder pressure.

The report was signed by: S. G. Down, chairman; H. A. Wablert; N. A. Campbell; J. R. Alexander and N. A. Clarke.

### OTHER BUSINESS

Other papers and reports were presented on Piping of Locomotives and Cars, and Hand Brakes for Heavy Passenger Cars. On Wednesday afternoon a lecture on the manufacture of iron tubes was given by R. W. Kenney, of the A. M. Byers Company, Pittsburgh. Motion pictures were shown illustrating the lecture. Walter V. Turner made a novel and interesting talk on Thursday afternoon. He showed by means of motion pictures the operation and the manner in which the air flowed through the various passages of the U. C. triple valve during the charging service application, emergency application and the releasing of the brakes. The possibilities of illustrating brake performance by this method is well worth considering in the matter of instruction. Mr. Turner also showed illustrations of various freak inventions which were both interesting and amusing. T. O. Sechrist, master mechanic, Louisville & Nashville, also addressed the association during the Thursday morning session.

The secretary reported a total membership of 1,177, and a cash balance of \$1,360.90. There were over 200 members present at the convention.

The following officers were elected for the ensuing year: President, T. W. Dow, Erie Railroad; first vice-president, C. H. Weaver, N. Y. C. West of Buffalo; second vice-president, C. W. Martin, Pennsylvania Railroad; third vice-president, F. J. Barry, N. Y. O. & W.; secretary, F. M. Nellis, Westinghouse Air Brake Company, and treasurer, Otto Best, Nathan Manufacturing Company.

### CLEANING PASSENGER CARS

The exterior of cars when very dirty from rain and dust should be thoroughly washed by means of a hose with a small nozzle and a brush on a long handle, one man using the brush while the other applies the water. This also applies to the trucks. When the windows are dry wipe them off with dry white waste or cheese cloth. This will in most cases give the outside a good appearance. In stormy weather this cannot be successfully done unless the cars are in a shed for protection. Air cleaning for the interior is preferred, as all dirt and scraps of paper can be cleaned out from behind and under steam pipes; then the ceiling and walls can be uniformly cleaned, as well as the lamp shades. The cushions should be thoroughly beaten about twice each week, taking them out of the cars and placing them on a rack made for that purpose. All seat arms and window sills should be thoroughly cleaned with white waste or cheese cloth.—*W. T. Clanton.*

CHOOSING STEEL OR MALLEABLE IRON CASTINGS.—The choice between steel and malleable iron castings is dictated partly by their respective properties, partly by price and partly by the limitations of the processes by which malleable iron is made. As pointed out in a paper read before the International Engineering Congress, steel is, in its nature, a more homogeneous metal and therefore tougher and stronger than malleable iron. Moreover, castings of malleable iron are somewhat prone to actual porosity or sponginess at the center, especially in certain portions of irregular castings, so that for this reason also a steel casting is stronger and more reliable. Finally malleable iron can be made only into castings of quite light sections, whereas there is almost no limit to the size and weight of steel castings that can be produced. For uses where only a fair amount of strength and toughness is necessary, and the castings are therefore of light section, it often pays to buy malleable castings, because they are cheaper than steel.—*American Machinist.*

# HOW TO DEVELOP THE CAR INSPECTOR

Suggestions From Several Viewpoints Which Were  
Made by Contributors in a Recent Competition

One of the most successful competitions which we have ever held was that for the car inspectors, which closed October 1, 1915. A number of the contributions to this competition were published in the November and December, 1915, and the January, February and April, 1916, issues. The present article is made up from the more important parts of papers which were presented by four contributors whose experiences enable them to comment on the subject from widely varying viewpoints.

BY W. E. PATTERSON

Air Brake Foreman, Car Department, Pittsburgh, Cincinnati, Chicago, & St. Louis, Logansport, Ind.

Men are being trained as car inspectors by practical experience and also by instruction in classes, which are held once a week in charge of a competent man, in order that they may become familiar with and thoroughly understand the rules of interchange and the laws as applied by the interstate commerce commission or government inspectors. We find that the best results can be obtained in the application and maintenance of United States safety appliance standards by dividing the work on the repair tracks into three classes, viz., truck inspectors, air brake inspectors and car body inspectors. This arrangement divides the responsibility, facilitates instruction and brings about better supervision.

The men are furnished with literature on the subject of car repairs and by close application and study become fitted to fill the next higher position. In past years very little literature was available on this subject at a price within the reach of all. This condition developed two classes of men. The one who studied became a theoretical man and the one who labored without study became the practical man, but the theoretical man was always the man selected to fill the higher positions; today conditions have changed. Literature may be obtained at a price which is almost ridiculous.

No man can become a competent car inspector without practical experience and study. The air brake, the rules of interchange and the laws of the country governing the maintenance of cars have become so broad and complicated that study is imperative.

BY S. E. NELL

Foreman, Chicago, Rock Island & Pacific, Carrie Ave. Shop, St. Louis, Mo.

A remark common among officers and foremen is to the effect that a car inspector is merely a necessary evil: in other words, he is stationed in the transportation yards to detect defects, and then proceed to bad order a car to the repair tracks. It is quite true that the inspector is necessary, but as to being an evil depends entirely upon his qualifications and training.

To become a successful interchange inspector the man should be promoted from the repair tracks to light repairman or safety appliance inspector in the train yards, inspector in straight inspection, and finally to the interchange point. The foreman of a repair track who makes a close study of his men will invariably find some who will qualify above the others in the gang and show more alertness, and these should be selected to make the start for better positions.

By first placing the candidate for the position of car inspector in the transportation yards as light repairman or safety appliance inspector, whichever he may be termed, he will familiarize himself with the handling of trains and gather information which will be of advantage in fitting him for the higher position. After the man has served enough time, and this must be left to the judgment of his foreman,

he should be promoted to car inspector, preferably in a straight inspection yard, where little or no interchange work will be necessary, but using him as extra inspector at an interchange point as much as possible, by swinging him in for the regular interchange man at times he is off duty. When the interchange opening occurs the foreman will not only have an available man, but one really fitted to become an ideal interchange inspector.

During the time of his training he should be schooled in the Master Car Builders' rules, and by the practical experience gained should be thoroughly familiar with the use and interpretation of these rules.

Foremen, by keeping in close touch with their men, not only perform a service toward the men, but also to their employer, as it will not only develop better workmen, but will prove an incentive to the car men with ambition and lift the entire department to a higher plane.

Some of the most prominent and best qualified men in car department affairs today have risen from the ranks of inspectors.

BY J. E. HELMS

Head Car Inspector, Atchison, Topeka & Santa Fe, Pueblo, Colorado

It is extremely important that the car inspector be honest, hardworking, have a fair education, know how to write a legible hand, be sober, and, above all, he must possess that indispensable qualification, judgment. No other endowment is quite so essential.

The M. C. B. rules are very complicated, and a thorough study of them, linked with some practical applications, will give the average car inspector a working idea of their intent and purpose. Along with this knowledge must be carried that of the local agreements, which, when governing the handling of traffic between several systems, become very complicated and often more difficult to apply than the M. C. B. rules.

If he be a yard inspector handling trains in and out of a terminal he must know the local rules of agreement and the M. C. B. rules; also how to handle the air and air brakes on passenger and freight trains in and out of the terminal; along with this he must also know how to execute the general orders with faithfulness and be governed by the bulletins issued from time to time by his superior officers.

The requirements prescribed by the interstate laws governing the standardizing of equipment must be thoroughly understood by the car inspector.

With these duties to perform, it is clear that he must of necessity be a very exact and intelligent individual, and though he has never been recognized as such, he is nevertheless one of the most important and useful employees of the railroad. Promotions come slow, owing to the fact that in his particular line of work he is set apart and usually away from the shop work or other duties connected with the car department, and thus little is known of his ambitions and many places are filled with men from the other departments for which he should have been considered.

In the past he has gathered his knowledge largely from his associates, and while he may have become proficient as to its general demands, yet he has been handicapped in becoming thorough and practical in every sense of the term in that he has not had or been given the support by the foreman and officers and many of the employees in the other departments, and thus has not been recognized as being an important factor in the road's development; but these conditions are fast changing, and soon the car inspector will attain a

relative position among railway employees, more in keeping with his work and responsibilities.

BY J. A. SOUDERS  
Hazleton, Pa.

The duties of a live and efficient car inspector are so numerous and the proper inspection of cars so vital to the operation of railroads that a car inspector must be more than a mere "car knocker." In order to obtain sufficient men for the position, it is necessary to give more time and attention to their training and development.

The youth who aspires to become a car inspector must of necessity have at least a common school education, embracing the three "R's"; reading so he will be able fully to interpret the meaning of the rules and instructions; writing so he will be able to neatly and legibly prepare billing, repair, defect, return, bad order, transfer and other cards, and keep the records neatly and correctly; arithmetic to make the various computations and keep such accounts as may be necessary.

If he has the above qualifications to start with, and is bright and active, not afraid of good hard work, and is given to understand that he will be given a chance to work himself up, by proper training he may be developed into a watchful, cool-headed and reliable car inspector, of whom the employer need not be ashamed, and who in time will make an excellent man for positions higher up.

As to his development, theory is a good thing, but not in itself; and in order to combine theory with the practical the young man should be employed at a car shop or in a car repair yard, preferably in the light repair gang, so he will become familiar with the different parts of the cars, the different kinds of cars, and the important as well as the weak parts of car construction and the various car failures.

He must also become familiar with the air-brakes, hand-brakes, safety appliances, couplers, uncoupling devices, etc. At the same time he should be given literature on cars and their parts, a copy of the M. C. B. code of rules, and should be a reader of the *Railway Mechanical Engineer*, to enable him to study up. If after a time he has made good, and can pass a physical examination, he should be promoted to the car inspector's force, under the eye of a capable foreman, until he is able to "hoe his own row."

To still further bring out the best that is in him, he should later be placed at a one-man inspection point, where he must look out for himself, and think and act for himself, thus making him careful, resourceful and efficient.

Another method, when it is not possible to start the young fellows out at a car shop, is to take from the ranks of car cleaners such men as have proven bright and observant, who want to make something of themselves, and are qualified in so far as educational and physical requirements are concerned. Their experience while engaged in and about cleaning cars is such that they will have absorbed considerable knowledge by seeing cars coupled up and uncoupled, brakes tested, seeing inspectors go over cars, and possible they may have given a hand in emergency cases. If given the necessary literature, and handled in the manner above outlined, they may also be rounded out and developed into good car inspectors.

The men while in course of development should be given all practical pointers, be encouraged if progressing satisfactorily, or reproofed and cautioned if in error, and also be fully instructed and examined on automatic air-brakes, safety appliances, and special rules of the company; this, together with the close observance of the M. C. B. code of rules and other car literature, will, in a short time, make them reliable and efficient car inspectors.

The qualifications of a real car inspector are, of necessity:

1. He must be sober and conscientious.
2. He must be careful and vigilant to discover defects and irregularities on equipment, which the untrained eye may

not be able to discern or which may appear trivial, yet which may endanger a train, or make cars undesirable or unsafe for movement.

3. He must work for the full interest of his road, and yet deal squarely with other roads, if at a junction point.

4. He must always be on the job, regardless of the weather, and bear in mind "Safety First" for himself, and others for his company's interest as well as for his fellow men.

5. He must have patience, so as not to "fly off the handle" at every little provocation, nor if other employes "jaw at him"; if he knows his business and attends to his business, right and proper, "He should worry."

6. He must continually study the M. C. B. rules, rules for loading materials, the various devices, new types of cars and materials, and read up on power and hand brakes and other car literature.

7. He must always use good judgment and think and act quickly.

To briefly sum up the required qualifications of a car inspector, we might say that they are: To be sober, industrious, studious, watchful, careful and reliable.

## DISMANTLING OF CARS\*

BY J. W. GERBER  
General Storekeeper, Southern Ry., Washington, D. C.

This paper is based on our experience in dismantling approximately 2,600 cars during the past four months. We began the work by hand, in a limited way, and as an experiment, about one year ago, so that when the order was received to dismantle 1,850 cars, and complete the work within 60 days, we had some knowledge of what was ahead of us.

The cars were unequally distributed at divisional points, the lowest number at any point being 1, the highest 539. Additions were made from time to time to the original assignment of 1,850 cars, the total having reached 2,900 to date, of which 2,600 have been dismantled as of May 1.

In doing the work the regular storehouse organization was used, requiring the addition of only common laborers to the regular labor forces. It was desired that special records be kept of the salvage derived from the cars, and at the points where any considerable number of cars were to be dismantled, special traveling auditors were assigned to the work in connection with their other duties. The material to be saved for the construction of other cars, or for use in repairs to cars, was passed upon by inspectors of the mechanical department, and every effort was made to save all the material for which service could be found.

While there was some variation at the different points in the method of dismantling the cars, the general plan was about as follows: Where possible, one or more tracks were secured that would hold from 10 to 20 cars each, the cars being spaced about ten feet apart. Four men were assigned to each car and the work on box cars was begun by two men stripping off the roof and two men removing the grab irons, brake staff and outside metal. The men removing the roof, before leaving the top of the car, loosened the siding at the plate, using for this purpose chisel-pointed bars. After removing the roof, outside metal and doors, the four men take down the lining, loosen the belt rail, and remove the siding. The upright rods are cut at the floor level, the longitudinal rods are taken out, the frame work is thrown to the ground and the rods still remaining in the frame are driven out. Two men remove the deck while two men take down the draft rigging and remove the air brake material. The bolts are drifted from the sills and the sills rolled to one side of the truck and turned over to the clean-up gang. If the trucks

\*A paper read at the thirteenth annual convention of the Railway Storekeepers' Association held in Detroit, Mich., May 15-17, 1916.

are to be dismantled, that work is done by the four men, if not, the gang is ready for the next car.

It has been our experience, in removing the siding from box cars, that the greatest difficulty lies in getting the material off in such condition as to be of some future service, and at the same time not to expend too much money in the work of taking it off. The largest use we have found for the siding is in re-working it for roofing boards, and while the length of the siding is sufficient to allow of some waste in cutting for roofing boards, it is necessary to remove it with either chisels or chisel-bars, as a man using a sledge hammer will produce mainly scrap wood.

The number of men in the clean-up gang varies with the local conditions, and if any considerable number of cars are to be taken down, consideration should be given to the location of the tracks on which the cars are to be dismantled, and the facilities for taking care of the lumber and metal reclaimed from them. Our best results were obtained with the following organization: One foreman; seven gangs of four men each taking down cars, and twelve men in the clean-up gang, a total of one foreman and forty men. Cleaning the track, assorting the metal, classifying and piling the lumber was done by the clean-up gang. This organization would dismantle not less than seven cars daily, working nine hours per day; while, as the gang became more efficient in the work the time of taking down the cars was reduced in many cases to 32 hours, or the time of four men working eight hours each.

What does the work of dismantling cars cost, and does it pay? It is not my intention to state the cost of labor in dismantling a car, but rather to give the number of hours in which a car can be dismantled, and any one interested in the problem can then apply the necessary labor rate.

Estimating the second hand lumber reclaimed at only 1,000 ft., board measure, per car, and at a value of \$10.00 per 1,000 ft., the lumber reclaimed from a box car will more than pay for the entire cost of dismantling the car and the handling of the serviceable material and scrap. To the saving effected by the second hand lumber there can be added at least \$1.00 per car for scrap lumber. There is a good demand for the second hand lumber. Freight car siding is cut to roof board lengths and is also used for the sheathing of buildings. Car lining is used for sheathing; car sills for foundation work and framing; and car decking for platforms. Material for a transfer shed, requiring about 325,000 ft. of lumber, was supplied by using reclaimed freight car lumber.

Additional savings will suggest themselves to any one familiar with the conditions of the metal from burned car bodies. Not only are the bolts, nuts, washers, forgings and castings in much better condition for use, if serviceable, but on the completion of the work of dismantling the cars you have all of the material, both serviceable and scrap, assorted and classified. This saves at least \$2.00 per car.

In conclusion, the dismantling of cars is no longer an experiment, it having been demonstrated that savings can be effected in comparison with the burning of the car bodies, the reclaimed material having a value very much in excess of the entire cost of the dismantling of the cars.

**PORTABLE TOOLS.**—An important factor in shop work is the portable electric motor drilling and reaming machine which has been developed in several efficient forms during the last decade. These portable machines, supplemented with the pneumatic riveting, chipping and caulking hammers, have virtually revolutionized shipbuilding, bridge-building, and structural steel work, and in the erection shop have wrought great changes, making possible rapid and efficient machine work on the parts as erected and thus saving labor and time through the elimination of transport to and from stationary machines.—*A. S. M. E. Journal.*

## HOLDING DOWN WHEELS WHILE CHANGING BRASSES

BY W. E. LEMP

Foreman Planing Mill, Louisville & Nashville, Mobile, Ala.

Considerable difficulty is usually found in changing journal brasses on the road owing to the fact that the wheel comes up with the box when the latter is lifted with a jack. A device has been developed by the writer to overcome this difficulty which is light and very simple to operate. It consists of two sections of pipe, one of which fits inside the other, and an automatic clamping washer which prevents them

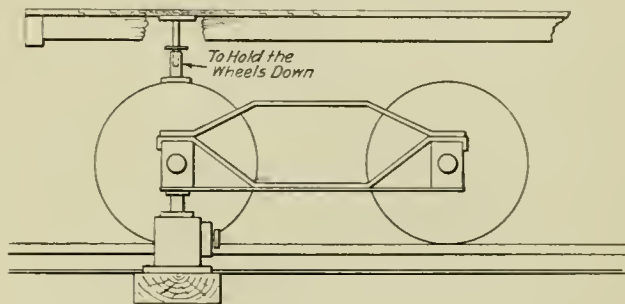

Device Applied Above a Car Wheel

from telescoping when under load. A  $\frac{3}{4}$ -in. pipe forms the lower section, and on the end of it is screwed a face plate curved to fit the tread of the wheel. The upper section is a piece of  $\frac{1}{2}$ -in. pipe to the end of which is attached a plate 8 in. long by 2 in. wide.

The method of operation is clearly indicated in one of the illustrations. The device is placed on top of the wheel and

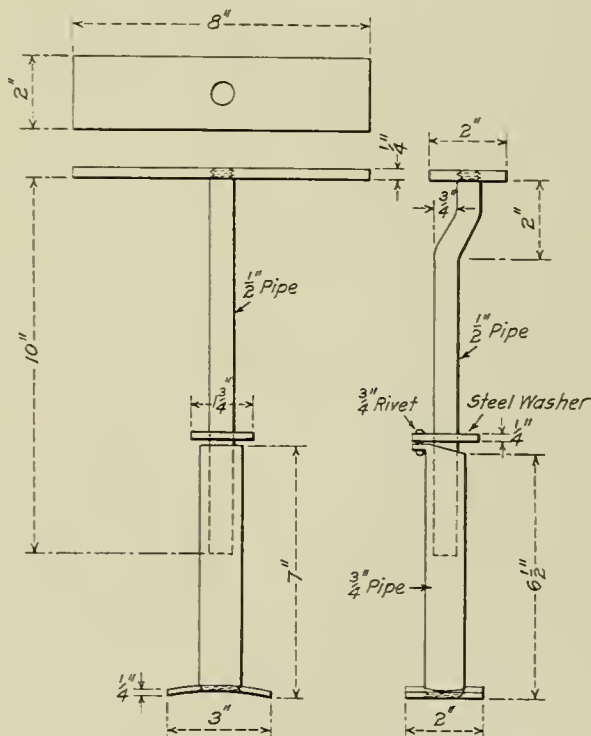

Automatic Clamping Device for Holding Down Wheels When Changing Brasses

extended until the top rests against the under side of the car frame. As the journal box is raised the upward pressure of the wheel causes the clamp to grip the  $\frac{1}{2}$ -in. pipe and prevent it from telescoping into the larger pipe, this action resulting in the holding of the wheel to the rail and facilitating the removal of the brass.

### SMOKE JACK FOR PASSENGER CARS

The revolving smoke jack for use with dining car ranges has usually proved unsatisfactory. The bearing is often clogged by a collection of cinders which prevents the hood from turning and in winter snow often banks up against it with the same effect. While the car is standing in a terminal if one of these ventilators happens to be turned the

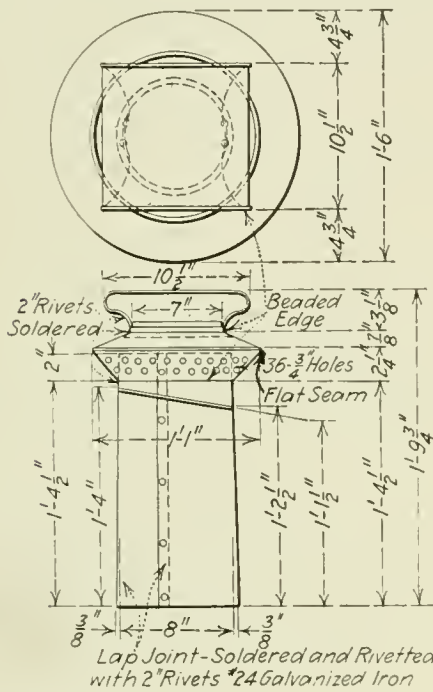

Fig. 1—Range Smoke Jack for Dining Cars

wrong way when the fire is started in the range, the car is usually filled with smoke and it is necessary to send a man up on the roof to adjust the position of the hood before a satisfactory draft can be secured.

In Fig. 1 is shown a substitute for this type of hood which

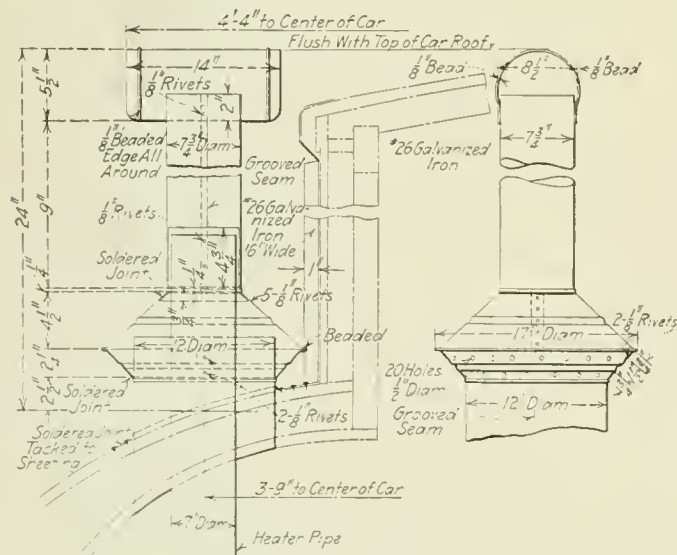

Fig. 2—Heater Smoke Jack

has been developed on the Canadian Northern and which has been made standard for its dining cars. This is a simple form of tee jack, the body of which is built up of No. 24 galvanized iron, the joints being both soldered and riveted.

With double coil heaters, having a barrel measuring from 20 in. to 24 in. in diameter, a 5-in. smoke pipe was formerly

used. This, however, has been changed to a 7-in. pipe with much better results. The type of jack now used is shown in Fig. 2. This jack is provided with a hood, as it has been found that unless the opening is protected rain and snow are driven down the pipe into the heater. The openings in the hood are placed laterally so that a slight vacuum is created when the car is in motion and the draft thereby accelerated. To secure the best results it has been found necessary to locate the jack with the top of the hood flush with the top of the car roof at the center.

### HAND BRAKES ON MOUNTAIN GRADES

Legislation requiring the use of air brakes on freight cars was enacted primarily in the interests of safety to the trainmen and not to facilitate railway operation, although the inventor and the railroads had both purposes in view in developing the air brake. In the decision of the United States court of appeals, Ninth district, which was noticed in the Railway Age Gazette of April 7, 1916, the court used this language in one of the sentences in the summary of its opinion:

The language of the act was equivalent to declaring that after the date named, freight trains should not only be equipped to run, but should actually be run without requiring brakemen to use the common hand brake.

In the first sentence of this summary, however, we find this statement:

It was the intention of Congress by the power brake provision of the safety appliance acts (27 Stat. 531; 29 Stat. 85; 32 Stat. 943) to make it unlawful to require brakemen to use hand brakes in the ordinary management and movement of freight trains in interstate commerce.

Again we find in the opinion of the court this statement:

The act by its terms expresses with sufficient certainty the intention of Congress that hand brakes shall not be used on freight trains in the ordinary movement of such trains in interstate commerce.

What is meant by "the ordinary movement of such trains in interstate commerce?" Is not operation on mountain grades abnormal, and should it not be considered as other than ordinary movement? On level roads gravity tends to assist the brakes in stopping trains, but on grades gravity works against the brakes. The efficiency of the air brake cannot be questioned, but in the interests of safety to the trainmen, it is not advisable to rely upon it entirely in operating on mountain grades, even though the brakes be in 100 per cent operating condition. The sudden failure of the air pump, error on the part of the engineer in handling the brakes, or a number of other factors which depend upon the human element or are beyond human control, may prevent the most efficient operation of the brakes and result in serious accident unless they are supplemented by the use of hand brakes. In operating on such grades brakemen should be so stationed on the train that in case of emergency they may be called upon to operate the hand brakes. On the other hand, the railroads cannot be excused from seeing to it that the brakes are maintained in the very best possible condition and that so far as it is humanly possible, such trains be braked 100 per cent. In the interest of both safety to life and protection to property operation over mountain grades should be construed as abnormal; the act is so worded that it was undoubtedly the intent to allow the use of the hand brakes, as far as it might be necessary, in such cases.—*Railway Age Gazette.*

EXPORTS OF QUICKSILVER.—The records of the Bureau of Foreign and Domestic Commerce, of the Department of Commerce, show that the exports of quicksilver from the United States for the calendar year 1915 were about 3,300 flasks, valued at an average of about \$67.73 per flask, against exports of 1,445 flasks in 1914. The imports entered for consumption are estimated for 1915 at 5,200 flasks, valued at about \$52.70 per flask, against 8,198 flasks in 1914.—*South-ern Engineer.*



# Shop Practice



## REPAIRING ANGLE COCKS

BY HOWARD W. STULL

Foreman Machine Shop, Philadelphia & Reading, Reading, Pa.

Probably very few railroad employees realize the large amount of money spent in maintaining angle cocks on railway equipment. When one considers that it requires two for each engine and car and that on the Philadelphia & Reading, for instance, there are over 1,000 locomotives and 50,000 cars, the fact that the aggregate value of the material involved is large, can readily be understood. In addition to the more than 102,000 angle cocks required on this equipment, it must be remembered that the store houses must carry a large supply to replace those that are broken or removed for repairs, which it is safe to say amounts to about 15 per cent or 20 per cent of the number in service including those which are in the shops for repair. This could probably be reduced if the engine houses and car inspectors would send in angle cocks to the repair shops more promptly.

At the Reading shops a department has been organized to

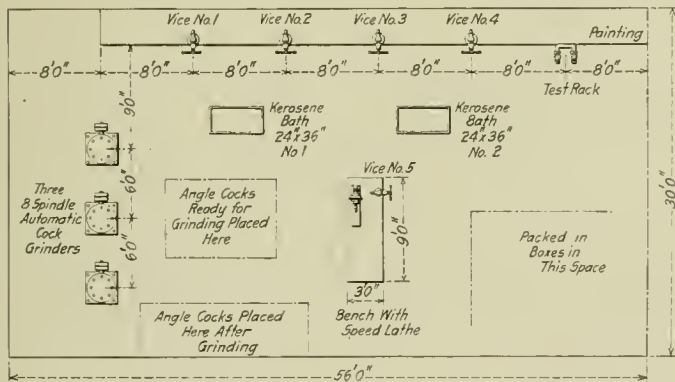

Diagram Showing the Layout of the Angle Cock Repair Department, Philadelphia & Reading

take care of all angle cock repairs for the road, the cocks being sent in from outlying points and redistributed through the store department. The layout of the shop in which this work is done is shown in the drawing. The equipment consists of a long bench on which are four vises, and a test rack, a small bench with a speed lathe, three automatic valve grinding machines belt-driven from a motor-driven line shaft and two kerosene oil baths.

The work is divided into five operations, all of which are paid for on a piece work basis. The first operation is performed at vises No. 1 and No. 2, where the handles and caps are removed. The body is tapped at both ends, and carefully examined both to insure good threads and to save further labor on those that may be cracked. The cocks are then put in the first kerosene bath, where the body and key are cleaned with a brush. When clean they are well blown off with compressed air. Any cocks that are found to have stripped threads on the hexagon end of the body are set aside to be retapped and bushed. This operation, known as "opening" on the piece work schedule, is done for \$1.70 per hundred cocks.

The cocks are then taken to the speed lathe bench and the keys screwed on the lathe mandrel, to be checked to run true. They are also eased off on both ends with a file and sand paper. This saves considerable time on the grinding machines. They are very carefully inspected to insure that they have the correct taper. By chalking the full length of the key the bearing can very readily be detected. If the bushing is cut or has ridges in its surface, it is reamed at vise No. 5 and a special size key fitted to it. The taper on these keys is 2 1/16 in. per ft. and the bushings do not require much reaming to renew the bearing.

This operation is known as "examining and filing" and is paid for at the rate of \$1 per hundred cocks. It reduces the grinding to a minimum; without it six grinders could hardly take care of the work.

In the third operation the cocks are ground on the three 8-spindle automatic cock grinders, which are operated by one man. A medium grade of Trojan grinding compound is used, this having been found to be superior to ground glass. The price for grinding is \$1.35 per hundred and 300 angle cocks are ground in ten hours.

After grinding the cocks are put in the second kerosene bath and the grinding compound cleaned off with a brush and compressed air. They are then assembled at vises No. 3 and No. 4, the handles not being applied until after testing. In assembling, the keys are greased with a mixture of one part beeswax, two parts tallow, and one part woolgrease melted together. Each man assembles 150 cocks in ten hours, including putting on the handles. This operation is known as "closing" and the piece work price is \$1.70 per hundred.

The testing is done by a salaried inspector who is held responsible for any poor workmanship on all operations. The painting and delivering to the store house completes the cocks ready for use. The painting is done for \$.26 per hundred cocks.

The following is a summary of the operations and the cost per 100 cocks, from which it will be seen that the cocks are repaired for about six cents each.

Opening .....	\$1.70	per hundred
Examining and filing .....	1.00	per hundred
Grinding .....	1.35	per hundred
Closing .....	1.70	per hundred
Painting .....	.26	per hundred

Total cost of repairs.....\$6.01 per hundred

### NUMBER OF ANGLE COCKS REPAIRED AND NUMBER PURCHASED IN ONE YEAR

	Opened for repairs	Scrapped	Scrapped account loose bushings	Stripped threads on hex. end to be rebushed	Furnished store house	Purchased new
April, 1915	4,998	1,106	307	..	3,894	1,388
May	7,362	590	197	534	6,438	1,502
June	4,296	757	176	280	3,259	2,385
July	4,637	1,208	280	378	3,051	126
August	4,064	325	193	197	3,739	376
September	3,618	164	162	147	3,809	..
October	4,990	486	209	232	4,386	..
November	3,382	399	136	123	2,696	76
December	6,031	620	207	202	3,350	..
January, 1916	4,832	602	201	134	4,112	2,400
February	4,684	635	250	157	3,116	2,502
March	6,364	747	152	127	4,362	2,400
	59,168	7,633	2,470	2,511	46,210	13,155

In the table is shown the output of the plant for the year ending April 1, 1916. During this period nearly 60,000 angle cocks were handled, of which over 46,000 were re-

turned to service. The difference was made up by the purchase of about 13,000 new cocks, each of which cost about \$1.37.

### GRINDING ROD PACKING CONE RINGS

BY W. W. ELFE  
Machine Foreman, Central of Georgia, Macon, Ga.

An expanding mandrel is illustrated herewith, which is used in the Macon shops of the Central of Georgia for grinding cone rings and push rings in piston rod packing glands. As shown, it is used on a sensitive drill press, the shank being

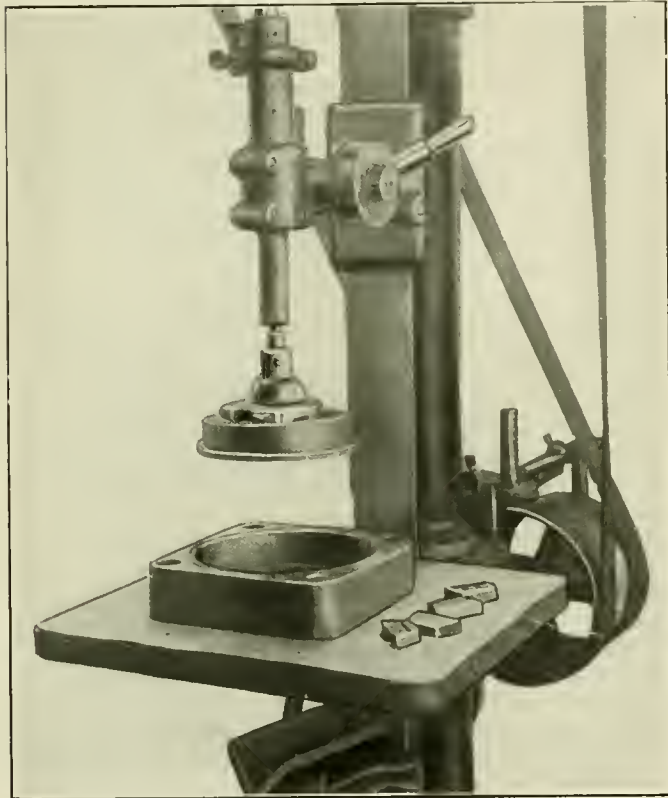

Flexible Cone-Ring Grinder for Use on a Sensitive Drill

fitted with a flexible joint to insure uniform pressure on all parts of the surfaces being ground. Two sets of jaws are provided for use in the chuck, one set being shown on the drill table. It has a range from 3 1/4 in. to 4 in.

### STEAM GAGE TESTING STAND

BY H. E. OPLINGER  
General Foreman, Atlantic Coast Line, Brunswick, Ga.

A very cheap but entirely satisfactory steam gage test stand has been developed on the Atlantic Coast Line for use at outlying points. Before this device went into use it was the practice to send a man out from the main shop with the weight machine to take care of this work, paying him time and a half.

The device consists of a simple hydraulic pump drawing water from a tin basin resting in the wood frame, suitable pressure and discharge pipe connections being made to a gage manifold at the top. The gage shown in the sketch must be a new one which is known to give correct pressure readings and should be sent in to the main shop once a month to be checked on the weight machine.

In operating the machine, after pumping up to the pressure desired, the stopcock in the pressure pipe may be closed and the pressure retained while the operator makes the necessary correction in the gage being tested. When the gage is

corrected the stopcocks should be opened in both pressure and discharge pipes, thus returning the water to the basin. The degree of accuracy of the work done with this device

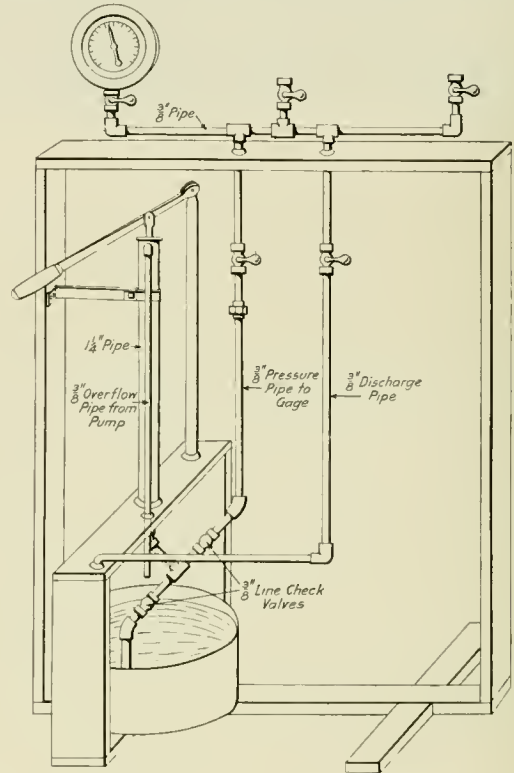

A Shop-Made Gage Testing Machine

has proved entirely satisfactory and its use has been approved by the Federal boiler inspector.

### DOUBLE RING TIRE HEATER

BY H. C. SPICER  
Gang Foreman, Atlantic Coast Line, Waycross, Ga.

The engraving shows a double ring tire heater for use with crude oil. It will be noted that the first ring has no holes in it, the second ring being drilled. This results in heating the oil in the first ring and generating the proper gas to insure

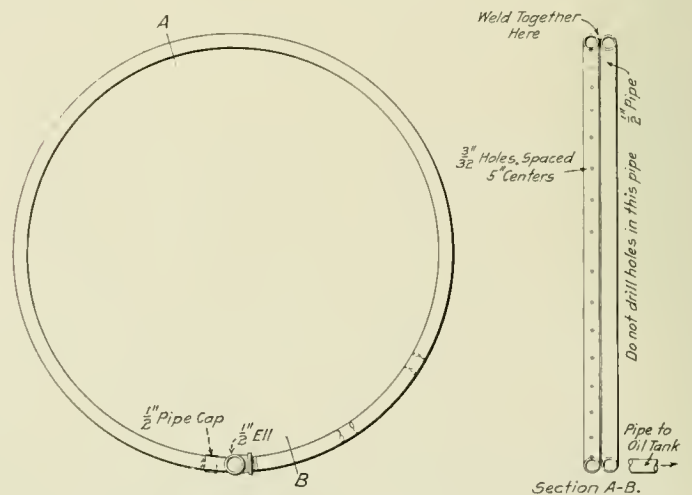

Double Ring Burner for Heating Tires with Crude Oil

burning. We have found this heater very satisfactory for removing tires. The size of the ring diameter is made to suit the size of the tire. This arrangement will heat a tire in one-half the time required by a single ring heater.



# MASTER BOILER MAKERS' CONVENTION

Electric Welding in Boiler Repairs, Maintenance  
of Superheater Flues, Renewing Wide Fireboxes



THE tenth annual convention of the Master Boiler Makers' Association was held at the Hotel Hollenden, Cleveland, Ohio, May 23 to 26, 1916. The convention was opened with prayer by John H. Smythe, a past president of the association, and the welcome of the city was extended by Mayor Harry L. Davis, to which Past President P. J. Conrath responded on behalf of the association. The annual address of the president was delivered by Andrew S. Greene, after which an address by D. R. McBain, superintendent motive power, New York Central, was read by the secretary, it being impossible for Mr. McBain to be present. The following is taken from the address:

#### MR. MC BAIN'S ADDRESS

I have noted with pleasure the subjects that are to be discussed at your convention. "Oxy-Acetylene and Its Advantages in Boiler Repairs," is one which should be given the closest attention. Notwithstanding the introduction of electric welding devices and the uses to which they can be applied with profit, it would be a mistake at this time to allow the oxy-acetylene process to drop out of our minds in the slightest degree. It has a distinct field in a certain line of work in which it will always prove more advantageous than any of the electric welding processes thus far developed. On the other hand the electric apparatus has a field distinctly its own which cannot well be covered by the oxy-acetylene process. Both systems should have our best thought that they may be developed to their highest points of advantage in our maintenance schemes.

The subject of the vibration of long tubes is one of considerable interest to me because I have made investigations in that line which have demonstrated that there is a certain movement of the tubes caused by excessive heat or cold, which considerably increased or decreased the sag in the longest tubes under the varying conditions of service from the time the fire is first applied to the locomotive until the time it is hauling its train on the road, the indications being that under certain conditions the sag is actually straightened out and under others it is increased.

When an engine with the tubes set in the old manner came in leaking badly it was possible to insert a piece of good thick paper between the bead and the back tube sheet; especially after the engine had partially cooled off. The boilermaker usually went into the firebox as soon as it was cool enough and the repairs usually resulted in clinching the tubes where they were with the ends anywhere from 1/64 in. to 1/32 in. further back in the firebox than they should be. This operation had a tendency, after it had been performed a few times, to shorten the distance between the tube sheets, usually resulting in pulling in the back tube sheet in the zone of greatest leakage. The bulging of front tube

sheets may be explained by a study of the conditions above referred to.

In closing his address Mr. McBain stated that he believed that someone, at sometime, would succeed in designing tube sheets which would take care of the expansion and contraction of the tubes in such a way that the stresses now due to unequal expansion would be relieved; and that when this end had been attained a large part of our boiler maintenance troubles would be overcome.

#### OXY-ACETYLENE PROCESS IN BOILER REPAIRS

At the 1915 convention this subject was very thoroughly covered and the report of the committee this year contained but little which is new relative to the application of the process to boiler repairs.

#### DISCUSSION

E. W. Pratt, assistant superintendent motive power and machinery, Chicago & North Western, showed a number of samples of the method being used on that road to weld tubes in the firebox tube sheet. A shallow recess is cut in the sheet around the tube hole in which fits a shoulder on the end of the tube, making the end of the tube flush with the tube sheet before welding. The weld is then built up on the end of the tube and the sheet, thus making it possible to remove the tube by chipping off the weld. The tube is set with a copper ferrule. Mr. Pratt called attention to the difference in the service of the welded tubes in good and bad water districts. Where the water is good no difficulty is experienced, but with bad water, welding has so far not proved entirely successful.

It was the generally expressed opinion that oxy-acetylene welding has a wide field of application which is continually extending. Although some members think failures may be due to the quality of the material used, the welder is generally responsible for poor results. At the Collinwood shops of the New York Central, the welders are checked up monthly with tests to determine the quality of work they are doing.

There was a difference of opinion as to the necessity of dropping the sheet when welding longitudinal seams in fireboxes. Where this method is adopted the sheet is usually dropped 1/8 in. per foot, this being taken up as the welding proceeds. A test was referred in which the sheets were tied so that they could not give, with the result that a stress of over 21,000 lb. was thrown on a sheet about 9 ft. long when the weld was completed, thus indicating a necessity for dropping the sheet. Other members use a corrugation to take care of the contraction as the weld cools, while others rivet sheets in place and put in the staybolts before doing the welding and get entirely satisfactory results.

### ELECTRIC WELDING IN BOILER REPAIRS

Most of our electric welding has been confined to the welding of flues. Since the installation of two one-man machines at Mount Clare, on each of which we have been running three eight-hour shifts, we have welded flues for 754 engines, 178,890 tubes, and 12,206 superheater flues. This was from July, 1913, to October, 1915.

We have welded a side sheet on a yard engine which has been in continual service since 1913, and the sheet is as good now as when welded as far as the weld is concerned. The firebox of one engine in service on our road has been welded complete.

To get good results, the machine should control the voltage so as to keep it uniform at the weld. Fluctuations in the voltage or amperes mean a difference of temperature at the weld. A weld will not be uniform throughout under such conditions. An automatic controller should be gotten up to control the voltage at the operator's hand. Without proper wire it is very hard to make a good weld, and a great many of the cracked welds are due to bad wire. We are now using a Swedish iron with good results. When welding a crack, the section of crack should be built up, and should be greater than the plate thickness by about  $\frac{1}{8}$  in. or 3-16 in. Layer after layer should be applied across the width and length of the crack until it is filled up. This method allows the metal to cool and prevents a great deal of contraction by removing the strain from the weld. All parts to be welded must be thoroughly cleaned with a roughing tool or sand blast. The latter is preferable when it can be used, as it cleans the work properly and removes all foreign substances.

The welding of tubes is very important. It is our practice to set all tubes back to head prior to welding, and the boiler must be steamed before welding so as to burn all the excess oil under the head. If this is not done, the weld will be porous, due to the oil coming out as soon as the welding begins. About the proper amount of current to use to weld tubes at our shop is 60 to 65 volt direct current, 130 to 145 amperes, using 5-32 in. diameter wire and also a flux coated

on the welding wire by dampening the wire and then applying flux, the wire to stand until dry. When welding flue sheets, door sheets, and door necks with electric weld, all the caulking edge must be chipped and cleaned with a roughing tool. All fire-cracks must be chipped to 45 deg. bevel. All the work must be caulked with roughing tool to close all pores in the metal after welding. If possible weld the tubes with water in the boiler. The water keeps down expansion and contraction of the tube and head and also exposes all defective welds.

Fireboxes can be welded successfully instead of riveting. Make the welds come in between the first and second rows of stay-bolts, which will stiffen them. To do this the flue sheet and door sheet flanges must be deeper. All mud ring corners can be welded by lapping the weld over the caulking edge. Caulk with a blunt square tool. If this is properly done it will eliminate further trouble. All shell patches can be welded along the edge, which will prevent trouble from leaks.

The average time to weld a set of tubes  $2\frac{1}{4}$  in. in diameter is at the rate of about 20 an hour; for superheater flues,

about 6 an hour. It takes about four hours to weld around the caulking edge of a tube sheet measuring about 18 ft. over all, averaging about 40 in. an hour steady welding.

The electric welding process can also be used on smoke-box connections, especially where the smoke-box and extension are in two pieces, thus preventing the possibility of burning and warping the plate, due to air leaking in. Patches can also be welded in smoke-boxes damaged in accidents. This method is safe and reliable and cheaper than riveting or acetylene welding.

The following information on the welding of steel plates was obtained from the Lincoln Electric Company: In sheet metal we have a product which has passed through a process which improves its quality, beyond that of cast steel. The result is greater compactness of the structure with a resultant increase in toughness. The welded piece of sheet metal will consist of two grades of metal, the original metal which has received mechanical treatment and the metal added by the welding process which has not received mechanical treatment and will always have, in general, the characteristics of cast steel. The metal in the weld may be hard or soft, of high or low tensile strength, but it will never have the toughness and ability to resist the tendency to crack in bending that is possessed by the rolled metal.

From the foregoing several general conclusions may be drawn: First, the tensile strength of the cast steel in the weld may be made less than, greater than, or equal to the tensile strength of the metal in the original section; second, the metal may be harder or softer than the metal in the original piece; third, the elasticity of the metal in the weld will always be less than the elasticity of the metal in the original plate.

The character of the finished weld depends on the composition of the metals being welded and upon the skill of the operator. A weld is made when the metals to be welded are in the liquid state with the slag and oxide floating on top. Flaws and imperfect welds in steel are due to the fact that the metals were not properly liquified and the presence of the oxide or slag, or both, prevent a perfect union. It

is a notable fact, however, that in autogenous welding the actual union is made in plain view of the operator, so that if it is not perfect, he knows it.

The single riveted lap joint is 55 per cent efficient under the most favorable conditions, while the quadruple riveted double strap joint may have an efficiency as high as 85 per cent. A skillful electric arc welder will make a joint which has an efficiency of 90 per cent without particular effort. Stiffness equivalent to that of the riveted joint may be produced by making the section of the joint greater than that of the unwelded section.

At the present time two kinds of electrode are in general use on sheet metal work: Norway or Swedish iron, or American equivalent, and low carbon steel wire. The iron wire gives metal in the weld of a tensile strength of approximately 40,000 lb. per sq. in., while the steel of .10 per cent carbon content may be relied upon to produce metal in the weld of a tensile strength above 50,000 lb. per sq. in. On plates of  $\frac{1}{8}$  in. thickness and less an electrode of 1-16 to 3-32 in. in diameter represents the best practice. A current density in the circuit of not to exceed 75 amperes should be used on this



Andrew Greene, President,  
Master Boiler Makers' Association

small electrode. Plates between  $\frac{1}{8}$  in. and  $\frac{5}{8}$  in. are usually welded with electrode  $\frac{1}{8}$  in. or 5-32 in. in diameter with a current density in the circuit of not more than 120 amperes. Plates thicker than  $\frac{5}{8}$  in. are usually welded with  $\frac{1}{4}$ -in. electrodes using a current density of approximately 170 amperes. An iron electrode may be melted more rapidly than one of steel and has less tendency to burn than the steel. In general, however, it is more difficult to weld with an iron electrode than with one of steel. To get the best weld possible, the current density in the circuit should be kept as low as is consistent with a usable arc.

Practically no applications of the electric arc process have been made on plates having a thickness of less than 1-16 in. where a butt joint is required. This is due to the great intensity of the heat with the consequent tendency to "burn through" where the edges of the plate are in small parallel planes. However, they may be melted together with a low current carbon arc with excellent results.

working. The subject was also discussed before the association at the 1905 convention, held in Buffalo, and it was well established that the tube sagged more or less according to the length. This sag was considered beneficial and with the tube submerged in water there is no vibration. The tubes will move, however, to some extent with the surge of the water in the boiler. This report was signed by C. L. Hempel.

DISCUSSION

Considerable difference of opinion was expressed as to the effect of vibration of tubes. Although there are in special cases evidences that considerable vibration takes place, there seems to have been but little trouble attributable to this cause, and in general no more with the long tubes on heavy power than with the shorter tubes on smaller power. Some trouble has been experienced from pitting with long tubes where the shorter ones are but little affected, it being suggested this may be due to the greater strain to which the metal of the longer tubes is subjected due to the greater weight and longer span between supports.

THE BULGING OF FRONT TUBE SHEETS

The sheets have a very small amount of material to assist in keeping them straight. The amount of work and the tools used, as well as the experience of the man doing the work of putting in the tubes, governs the bulging of the sheet, which the following record and experiments will show.

By using hand rollers each hole stretched .007 in. With the self-feeding roller and hand pin the hole stretched .029 in. With the self-feeding roller and air motor the hole stretched .021 in. By taking as a basis a tube sheet having 400 holes, the first method stretched the holes  $400 \times .007$ , which equals 2.8 in. The second operation stretched the holes  $400 \times .029$ , which equals 11.6 in. The third operation stretched the holes  $400 \times .021$ , or 8.4 in. The amount of excess material is distributed over the space worked upon.

As the bridges between the flues do not upset proportionately to the increase in the sizes of the holes, to do the stretching of the material at certain points each individual hole must take care of a portion of the material around it, thus making the bulging of the sheet a local condition. This test was made with a  $\frac{1}{2}$ -in. sheet and a 2-in. tube, .135 in. thick.

The report was signed by J. B. Tate, chairman, John Smith and Martin Murphy.

DISCUSSION

The generally accepted explanation of the bulging of front tube sheets is the expansion of the tube holes due to working the tubes. Methods of overcoming it or reducing its bad effects to a minimum vary. Some members considered the

bulging itself to be of little consequence if proper care were exercised in working the tubes, but they had had trouble from cracking at the heel of the flange. To overcome this the thickness of the sheet has been increased to  $\frac{3}{4}$ -in., a  $\frac{5}{8}$ -in. firebox tube sheet being used. Others consider it only necessary to keep the back tube sheet straight, and let the front tube sheet go as it will. The use of a tube sheet with a corrugation adjacent to the flange around the belly of the boiler and over the top of the tubes was suggested as a means of taking up the expansion in the sheet without bulging. A



D. A. Lucas, 1st Vice-Pres.  
Master Boiler Makers' Association

The report was signed by P. F. Gallagher, chairman.

DISCUSSION

The discussion of this report was largely on the welding of tubes at the firebox tube sheet, to which electric welding has been extensively applied. There has been no difficulty in securing excellent results in good water districts, but where bad water is used the results have been much less satisfactory. When the welded tubes begin to leak and are worked over, the welds of adjacent tubes which were previously in good condition are loosened and the trouble rapidly spreads. In some cases, where bad water is used the tubes are welded because of the decreased amount of roundhouse work required while the welds last, although the life of the tube is not greatly extended. With coals which tend to honeycomb the sheet some difficulty has been experienced with welded tubes, the increased thickness of the bead tending to increase the accumulation of honeycomb and the number of steam failures.

On the Union Pacific where firebox sheets are electrically welded the practice of dropping the sheets  $\frac{1}{8}$ -in. per foot was originally followed, it being found that at the completion of the weld the sheet would be drawn up into place. It was found, however, when the weld was pounded lightly with a hammer as the work proceeded, that the sheet did not take up. The strain on the weld had apparently been relieved by the pounding. This practice has therefore been adopted, the sheet being placed with no allowance for contraction.

DO LONG TUBES VIBRATE?

The committee which was appointed to investigate the effect of the motion of the locomotive on tubes of such length and thickness that they sag on being applied to the boiler, presented an abstract of the report of a test made by the New York Central, which was presented before the New York Railroad Club in May, 1910. The test was made on a Pacific type locomotive, the tubes being set with a depression of 1 5-16 in. at the center. A recording device was attached to one of the top tubes, the arrangement being such that the movement of the center of the tube relative to the boiler shell could be recorded. This test indicated that there is some increase in the sag of the tube when the engine is



John B. Tate, 2nd Vice-Pres.  
Master Boiler Makers' Association

case was mentioned, however, where a Wood firebox was removed on account of corrosion, in a bad-water district, after 28 months' service, in which the corrugated tube sheets were both bulged, the front about 1in. and the back  $\frac{1}{2}$ -in.

#### CLEANING AND MAINTAINING SUPERHEATER FLUES

Keeping superheater flues free from cinders and clinkers depends upon the roundhouse forces, and more particularly upon the boiler foreman and inspector. It is very important that they be inspected before each trip. Flash lights or electric lights with shields should be provided for this purpose. It should be required that the clinkers and cinders be removed from the superheater tubes at the end of each trip. Steel bars from five to eight feet long with a chisel point should be used to break up the clinkers and honeycomb off of the end of the unit and other bars with hooks at the ends should be used to pull the clinkers out of the tube. If they are blown back into the flue they are liable to lodge on the supports of the unit pipes and will soon clog the superheater flues. A  $\frac{1}{4}$ -in. or  $\frac{3}{8}$ -in. pipe not longer than the tube should be used for blowing out the soot and cinders, care being taken

least three inches from the inside of the flue sheet flange.

The report was signed by T. F. Powers, chairman, and W. M. Wilson.

#### DISCUSSION

The importance of thoroughly and frequently cleaning cinders from the inside of superheated flues was emphasized. A case was mentioned where cores the full size of the flues and eight inches long have been removed from these flues when they have been neglected, the engines, instead of being better and more economical than saturated engines, becoming less economical.

Thoroughly cleaning the scale from the outside of the flues while they are in the boiler has been found difficult with some kinds of water. It being necessary to enter the boiler while the small tubes were out and knock the scale off by the use of a bar. Although they cannot be cleaned as well as when removed they usually can be made to go until the second shopping for the removal of the small tubes. In rattling the large flues in the barrel type rattler it has been found that they can be handled without injury if the rattler is as completely filled as possible. In rattlers of the submerged type



Chas. P. Patrick, 3rd Vice-Pres.  
Master Boiler Makers' Association



Thomas Lewis, 4th Vice-Pres.  
Master Boiler Makers' Association



T. P. Madden, 5th Vice-Pres.  
Master Boiler Makers' Association

that the pipe is run under the unit pipes, and pulled back and forth until the flue is cleaned. The best time to clean the superheater flues is, of course, at the washout period when the engine is cool, but this depends upon the grade of coal used, for with the use of some coal it is necessary to blow and clean them each trip.

As it is not necessary to remove the superheater tubes at the end of the three-year period in order to comply with the law, if the boiler can be cleaned and inspected, it is recommended by many railroads that the superheater flues be welded at the fire-box end. The tubes can be cleaned on the outside or water side while in the boiler by the use of scraping rods and bars, pneumatic flue cleaners, and sometimes by heating the flues.

When it is necessary to safe end superheater flues, many railroads recommend that not over one safe end be used. When the old safe end is cut off each time it is at least possible to re-tip the tube three times. After that they can be cut down for shorter engines. It is the recommendation of this committee and other boiler foremen that the safe end go on the fire-box end, where the condition is more severe, and where the new material is most needed.

There has been a tendency on the part of some designers to crowd the corner superheater flues too close to the flange of the back flue sheet. This has resulted in cracks out from the flue hole which can only be repaired by welding. Where the welding does not hold, it is necessary to renew the flue sheets. It is recommended that the outside edge of the superheater flue hole be kept at

the mixing of 2-in. or  $2\frac{1}{4}$ -in. tubes with the flues has been found to prevent denting and flattening of the latter.

#### REMOVING AND REPLACING WIDE FIRE-BOXES

After removing all tubes, the boiler should be taken from the cylinders and frames and placed on the floor in the boiler shop, all stay and crown bolts drilled out with air drills, or cut off with the electric or acetylene process, cutting mud-ring rivets off with hand chisels or punch and sledge, or by the use of an air hammer or rivet buster; then break the stay-bolts down with a staybolt breaker or leave them in the old fire-box sheets, dropping the sheets or pieces of sheets on the floor. After this has been done all stay and crown bolt burs can be cut or burned out of the holes. All necessary repairs to the cylindrical parts as well as the fire-box sheets are made and the sheets cleaned while the new fire-box is being fitted up, riveted and caulked.

It is not necessary to remove the back head or disconnect the boiler at throat sheet to apply wide fire-boxes; neither is it necessary to remove any boiler braces, except those applied to the back flue sheets. If the boiler is on the floor and crane service is available, it can be turned over in any desired position. This is a very great advantage.

In applying these fire-boxes the committee differs some as to the manner in which this work should be done. In some localities the sheets are applied one at a time, and bolted up inside of the fire-box casing. Where the fire-boxes are applied in this manner, the rivet holes are all countersunk and rivets driven on the inside of the fire-box by the use of air

hammers. It is claimed that by this method the flanges of the sheets are protected, and there will be less trouble on account of sheets cracking out at the rivet holes. It is the opinion of a great number of men that the boiler should be removed from the frames and taken to the boiler shop. When this is done the fire-boxes should be fitted up, riveted, chipped and caulked, both inside and outside, ready to be put into the casing by the time the boiler has been cleaned and repairs made to the barrel and outside fire-box casing sheets. The fire-box can then be put in place, if cranes are

available, by turning the boiler with the muddring opening up. After this is done and the fire-box is bolted in place, the boiler is let down on the floor and the fire-box door ring is riveted, usually by driving hammered rivets. In some instances it is welded. The mud-ring is then put in place and riveted with a mud-ring riveting machine or air hammer, and then chipped and caulked, the roof and staybolts being applied in the usual manner. All staybolts are driven with an air hammer or stay-

bolt driving machine, and should be held on with an air holding tool.

The committee does not think it advisable to cut the back head out or disconnect the boiler at the throat sheet at any time to remove any wide type fire-boxes. This is not only an unnecessary expense, but it will destroy a good tight seam or joint. The driving out of the rivets is liable to cause fractures and cracks in the plates. Any wide type fire-boxes can be removed and applied without disconnecting the boiler at throat sheet, or cutting out the back head, by one or the other of the above methods, i. e., by applying the boxes after they have been riveted together, or by putting in one sheet at a time and riveting all inside of the boiler. The only objection to the latter method is that the sheets cannot be brought up tight on the water side, and it is impossible to caulk them.

The report was signed by B. T. Sarver, chairman, A. N. Lucas and Bernard Wulle.

DISCUSSION

The consensus of opinion expressed was in favor of leaving the back end on the boiler when renewing fireboxes. Further than this the methods to be used must depend largely on the facilities of the shop, conditions in this respect varying widely.

CUTTING OFF STAYBOLT ENDS WITH OXY-ACETYLENE

The threads on the staybolts or on the sheet are unduly strained by the use of nippers, and the ends of the staybolts are left with two long corners, making them more difficult to rivet over. The chisel bar and sledge are 50 per cent worse than the nippers in the amount of damage done to the threads on the sheet and staybolt.

The advantages of cutting off ends of staybolts with oxy-acetylene are: First, the bolts are not disturbed after they are once applied; second, we get a uniform length to drive without long corners, and, third, the heat anneals the end of the staybolt. This is a great advantage in the riveting, as the operator is better able to do a good job in upsetting the bolt without leaving any ragged edges. As all staybolts are applied from the fire side of the fire-box, this is a great advantage

where a first-class job is desired. Some may think that by cutting off staybolts in this manner the heat penetrates through the bolt to the fire-box sheet, but this is not so, as the operation of cutting is done so quickly the heat does not have time to reach the sheet.

The report was signed by Thomas Lewis, chairman, and W. G. Bower. A minority report was presented by L. Borne-man, a member of the committee, from which the following is taken:

I have been unable to cut off very many staybolts with oxy-acetylene, but I have cut off a sufficient number to prove that we cannot cut them off as cheaply as we can with the stay-bolt nippers. One-half hour is all the time required for cutting one side of our largest engines, which are the Mikado type. Our nippers are hung from the crane and the bolts are cut off as fast as the machine can be transferred from one bolt to another. We have the Helwig staybolt nipper in two sizes, one machine for small bolts and one for larger bolts such as radial stays. We have one man rated at 26½ cents an hour who handles these machines exclusively with a helper receiving 23½ cents per hour. I note in cutting the bolts with oxy-acetylene the sheet gets so hot that it is impossible to place the hand on it in some places.

It may be recommended as inexpensive on general repairs to use oxy-acetylene in cutting off a number of bolts scattered on the boiler and as preferable to using a chisel bar.

I do not recommend the application of bolts from the inside sheet. In tapping out a staybolt hole with a motor, the vibration of the motor hanging from a pulley has a tendency to increase the size of the hole where first entered. The hole in the second sheet as a rule is of the original size of the tap. When entering the bolt, it will always be noted that it will not be as tight in the hole that the tap was first entered in as in the second hole; thus you are able always to get a good tight bolt on the inner sheet where it is absolutely necessary in order to prevent leaky staybolts, by applying the bolts from the outside sheet.

DISCUSSION

Where the use of the oxy-acetylene burner has been tried in the removal of staybolt ends it has usually proved successful. Where difficulty has been experienced due to the hard-

ening of the bolt ends or heating of the sheets, making them less easy to rivet, it is attributed to improper regulation of the flame, requiring its application to each bolt for too long a time.

BASIC VERSUS ACID STEEL FOR FIRE-BOXES

Acid open hearth steel may be distinguished from basic open hearth steel by its being normally higher in silicon and usually in phosphorus, but lower in manganese.

The acid open hearth furnace is heated by burning within it gas and air, each of which has been pre-heated before it enters the combustion chamber. The metal lies in a shallow pool on a long hearth which is lined with silicious material, and is heated by radiation from the intense flame. The impurities are oxidized by slag lying on top of the metal. This operation is hastened in two ways: iron ore is added to the bath; and the carbon is diluted by adding with the furnace charge large



Harry D. Vought, Sec.  
Master Boiler Makers' Association



Frank Gray, Treas.  
Master Boiler Makers' Association

proportions of steel scrap, often as much as 75 or 90 per cent. It takes from six to ten hours to purify a charge. The manganese and silicon go into the slag first, then the carbon boils off as a gas. When this has proceeded to the desired point, the bath is recarburized and the metal is cast into ingots. The characteristics of the acid open hearth process are: A long time in purification; large charges are treated, usually 15 to 100 tons to a furnace; at least a part of the charge is melted in the purification furnace, and the furnace is heated with preheated gas and air.

The basic open hearth process is similar to the acid process, with the exception that a sufficient amount of lime is added to the bath to form a basic slag. This slag will dissolve all the phosphorus which is oxidized, which an acid slag will not do. The characteristics of the basic open hearth process are the same as those of the acid open hearth process, with the following additions: Lime is added to produce a basic slag; the hearth is lined with basic instead of silicious material, in order that it may not be eaten away by this slag, and impure iron and scrap may be used, because phosphorus and, to a limited extent, sulphur can be removed in the operation.

Acid open hearth steel is believed by engineers to be better than basic, and is usually specified for all important structures, although not so rigidly today as a few years ago. The basic process is less expensive than the acid, because high phosphorus pig iron and scrap are cheap, and the lower cost of materials used more than balances the greater cost of the basic lining and lime additions, and the circumstance that the acid furnace has a higher output because heats are shorter. Acid steel is to be preferred for the following reasons:

A basic slag will dissolve silicon from the metal; therefore, the recarburizer is added to the steel after the steel has left the furnace, instead of in the furnace as in the acid process. Should any basic slag be carried over with the metal, however (which is liable to happen), there is the danger that the ingots will be too low in silicon. They are then impregnated with blow holes. A goodly portion of the acid open hearth steel goes into steel castings, where the presence of blow holes would be injurious.

The recarburizer does not mix with the steel as well as if it were added in the furnace.

A basic slag is more highly oxidized than an acid slag, therefore the metal at the end of the operation is more highly charged with oxygen. For this reason a larger amount of manganese is added in the recarburizer.

It occasionally happens in the basic process, after the phosphorus has all been oxidized in the slag and the operation is ended, a good deal may get back into the metal again. This is especially liable to happen when basic slag is carried over into the ladle before the recarburizer is all in. A reaction may then take place between the basic slag and the acid lining of the ladle, the slag being enriched in silica, and phosphorus forced out of it into the metal.

The committee made no recommendation endorsing either process as the best for the manufacture of fire-box steel. The report was signed by J. C. Clark, chairman, and H. J. Raps.

#### CRACKING OF BARREL SHEETS

Barrel sheets are likely to crack in any part of the boiler, but cracks occur most frequently in the lower part of the boiler at the girth seams, usually running in girth seam direction. This is caused by pitting or corrosion. Cracks also occur on the lower half of boiler where frame braces or tee irons are riveted or studded to the barrel sheets. The sheets generally crack at the end of the tee or angle irons, the crack running lengthwise of the boiler. These cracks are likely to be found extending in almost any direction, according to the cause. We believe the cracks found here are due primarily to bad condition of the machinery, such as bad pounds or

broken frames, causing undue strain upon the barrel sheets at these points.

Cracks occur at the longitudinal butt joint seams between the rivet holes, in a longitudinal direction, or at the edges of outside welt straps, in a longitudinal direction. These cracks are either due to improper design of the boiler, bad workmanship, or possibly poor material, mostly to bad workmanship. Either the sheets have not been properly rolled or the rivet holes have not been drilled and carefully reamed.

Cracks also occur where washout plates are applied to the bottom of the boiler. Such cracks generally begin at the edge of the washout hole made in the barrel sheet and extend outward in any direction. This is caused by decreasing the strength of the sheet in cutting away the washout hole.

The only way to prevent cracking at the bottom of boiler at girth seams is to keep the bottom of the boiler clean and free from the impurities which cause pitting and corrosion. Cracking of barrel sheets where frame braces and tee irons are riveted or studded to the sheets can be overcome to some extent by applying reinforcing plates of proper thickness and design to the inside and the outside of the boiler where the braces or tee irons are located. Cracking at the longitudinal butt joint seams can be overcome by greater care in rolling the barrel sheets and properly drilling and reaming the rivet holes. Cracking at washout plates can be overcome by applying reinforcing plates on the inside and outside of barrel sheets where the washout plates are applied.

The report was signed by C. R. Bennett, C. N. Nau and Joseph McAllister.

#### DISCUSSION

The point which received the most discussion was the cracking of the barrel where waist sheet angle or tee-irons are attached, this being attributed to interference with free expansion and contraction. On the Chicago & North Western the angles are being applied without rivets, a wearing pad being attached to the boiler shell against which the angle rests. On Mallet type locomotives the weight of the boiler, which rests on the forward carrying saddles, under certain conditions is considered excessive for the sheet, causing a tendency to spring the barrel and start cracks. The importance of properly lubricating the expansion pads was mentioned, the boiler shell being subjected to excessive stresses when the pads stick.

#### THE FUSIBLE PLUG

The design of the fusible plug is similar to the washout plug in its general construction, except it is not so large, and on its inner face is made conical or concave to a depth within about  $\frac{3}{8}$  in. or  $\frac{1}{2}$  in. of its entire thickness; a  $\frac{1}{4}$ -in. drilled hole passing through. This brass plug, measuring about  $1\frac{1}{4}$  in. to  $1\frac{1}{2}$  in. in diameter, contains the fuse of soft metal which should melt at not less than 650 deg. F. It is applied between the first and second rows of crown bolts or radial stays at the front end of the fire box near the back flue sheet.

The moment water in the boiler becomes sufficiently low to expose this part of the crown sheet to the direct attack of the fire, unprotected by water, the temperature at this point will increase rapidly to such a degree as to cause the fusible metal in the plug to melt and flow out through the  $\frac{1}{4}$ -in. opening in the bottom of the plug, followed by steam which extinguishes the fire without further damage. If the plug is to perform its function, it must be given the proper attention. It should be removed and cleaned at least once every 30 days; preferably at the time of each stay bolt inspection. If permitted to remain in the crown sheet, for an indefinite period, a thin scale will form over the fusible metal and an accumulation of mud will gather around the plug, thus keeping water away from it and causing the soft metal to melt when there is plenty of water in the boiler.

In the foregoing we have dealt with the design of the fusible plug, its function, advantages and abuses, but in the following we wish to point out its positive disadvantages:

First—In placing these plugs between the first and second rows of crown bars or radial stays in forward end of firebox they are subjected to severe temperature conditions and are frequently burned out.

Second—The thickness of the plug places the firebox side an excessive distance from the water. This permits the brass part to reach a high temperature which may be sufficient at times to cause the fusible metal to melt without low water.

Third—Variations in temperature between the plug and the crown sheet surrounding it, render difficult the maintenance of a tight joint in the sheet. The square having become defective, and the threads burned and corroded, it is almost impossible to tighten effectively with a wrench. Therefore, it is necessary to resort to the hammer and caulking tool to stop the leakage, or remove the plug, clean out the threads and apply a new one. This we deem necessary once a week, or at the end of each round trip, water conditions governing. This procedure will rapidly enlarge the hole in the crown sheet, as well as increase the diameter of the plug, making it necessary in a short while to apply a patch, or bush the hole in order to reduce it.

Fourth—The continuous and frequent removal of fusible plugs in order to maintain them tight and serviceable, would require the lowering of the water each time this operation was performed, and when terminated the water would necessarily have to be raised.

The fusible plug has doubtless been used, more or less, on all of the railroads of this country, but seems to have met with disfavor, and is now being dispensed with.

The report was signed by A. R. Hodges, chairman; F. A. Batchman, and Wm. M. Keating.

#### CLEANING BOILERS WITH TUBES REMOVED

The ordinary method of cleaning scale out of boilers is by the use of the pneumatic hammer with special scaling tools. A light, rapid hitting hammer is believed to be more profitable than an ordinary size hammer, such as is generally used around the boiler shop or roundhouse, being both quicker and less liable to scar the plates.

The use of a wet sand blast for cleaning scale from boiler sheets is open to objection in that it is hard on the operator and makes the shop where the work is done very dirty. The cost per engine is not much less than with the hammer method, but a better job is done.

Some replies received by the committee indicate that a slight scale is beneficial rather than detrimental; cleaning seams, laps, flanges and the lower part of the shell for inspection purposes is considered all that is necessary. This can be done cheaper than going over all parts of the boiler thoroughly. In general, however, thorough cleaning of the boiler is favored.

The conclusions of the committee are:

First—When tubes have been removed the boiler can ordinarily be cleaned by the use of the air hammer scaling tools in from 8 to 15 hours. Where the fire-box has also been removed it will require about five hours longer.

Second—The picks and air tools should not be sharp enough or hit hard enough to scar the metal, not because of any liability to increase pitting, but because the roughened surface is liable to make the next job of cleaning more difficult.

Third—The sand blast method, taking into consideration the cost of sand and apparatus and its maintenance, is no cheaper than the other method. The boiler is much more uniformly cleaned however. The system might be profitably employed where special facilities, such as a cleaning pit with crane service to bring the boiler to it, could be provided.

The report was signed by George Austin, chairman; T. J. Reddy and C. C. Dean

#### DISCUSSION

Where the wet sand blast process is used it is necessary to have a fine gravel as sand will not operate successfully. Where the sand blast is used, either wet or dry, it is impossible for any other work to be done around the boiler while the cleaning is in progress.

#### MR. McMANAMY'S ADDRESS

Frank McManamy, chief boiler inspector, Interstate Commerce Commission, delivered an address before the association on Wednesday morning, from which the following is taken:

A review of the subjects discussed at its various meetings indicates that much constructive work may be accomplished by this association. Its value, however, will be largely if not entirely governed by the accuracy and reliability of the reports submitted, on which the action of the convention is based. Nothing will do more to prevent this association from attaining its legitimate and proper position as a leader amongst authorities on boiler work than presenting matter to the convention as the conclusions of committees that is not based on actual and accurate tests or performance records.

Many of us have been in railroad service when comparatively little attention was paid to the safety of employees, and looking after himself was considered a part of the employee's duty. Something over 25 years ago the number of men killed and injured in railroad service began to attract the attention of the public, and movements were started by the employees to obtain the passage of laws for the promotion of safety for railroad men. It was only after a number of years spent in the work and after a number of laws had been passed and enforced to an extent which proved that it not only was a protection to their employees, but it was actually cheaper to protect employees than it was to pay for their injuries, that the movement was actively taken up by the railroad companies under the slogan of "Safety First."

This association or its members can do a great deal to promote safety. The men of whom it is composed have charge of large shops and many workmen who are engaged in the construction and maintenance of locomotive boilers and their appurtenances, and are therefore responsible in a great measure for the safety, not only of the workmen who construct, but those who operate the product. No industrial operation is of sufficient importance to justify the unnecessary loss of human life in its accomplishment.

The purpose of the locomotive boiler inspection law and of the amendment thereto was to promote safety. The organization created thereby represents but a small part of the work which the Federal Government is doing for the protection of life and limb. In its particular field, however, remarkable progress has been made.

The amendment to the Federal laws of March 4, 1915, extending the work of the Federal inspectors to the entire locomotive and tender, as well as to the locomotive boiler and its appurtenances, has made absolutely no change in the Federal locomotive boiler inspection law, and none in the method of its enforcement. It is true it has added to the duties of Federal inspectors, and perhaps will make it impossible for them to inspect so many locomotives, but no change will be made in the method of handling the work under the locomotive boiler inspection law.

#### THE MUD-RING AND THE CRACKING OF SIDE SHEETS

The illustration shows a cast steel mud-ring invented by W. C. Smith, assistant mechanical superintendent, and Charles Harter, mechanical engineer, of the Missouri Pacific.

This ring is channel shaped with flanges on each side to take the fire-box sheet, the inner flange being half a stay-bolt

pitch shorter than the outer flange in order to facilitate the welding of fire-box sheets to same and keep the seam below the fire-line; also to secure a row of stay-bolts in casting and sheet in order to take care of the stresses in welds.

To secure the two walls from spreading and give required stiffness at the bottom of the ring, braces are cast between the walls. In these braces a  $\frac{3}{4}$ -in. hole is cored to lighten the casting.

A mud-ring of this description will have many advantages

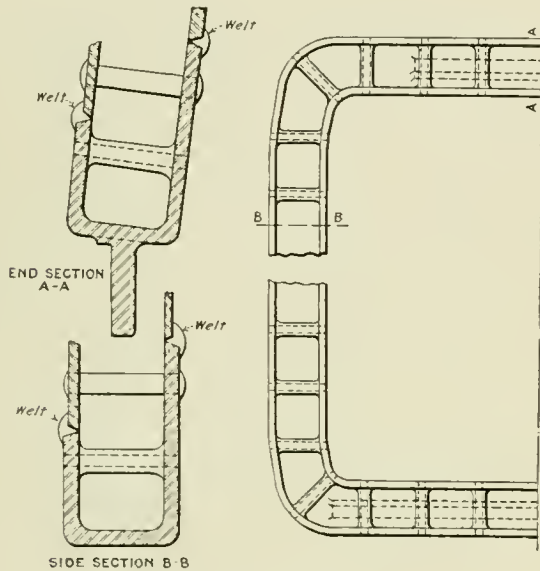

Cast Steel Mud-Ring Welded to the Sheets, Developed on the Missouri Pacific

over the present ring in use. Being very much lighter in construction naturally makes it more flexible and eliminates stresses in firebox sheets caused by the rigidity of the present design. It will be a smooth surface on side sheets, permitting cinders and ashes to pass into ash-pan and prevent side sheets from rustling away, owing to the rivet heads of mud-ring obstructing ashes that pass between the grates and side sheets. With the mud-ring welded it should also eliminate all mud-ring corner trouble, which is very annoying as well as costly to railroads in bad water districts.

There are many other good features in connection with this style of mud-ring which can be discussed at the next convention.

The report is signed by T. P. Madden, chairman.

DISCUSSION

In presenting the report, Mr. Madden stated that some modifications have been made in the design of the mud-ring since the drawing accompanying the report was made, the bottom of the ring having been changed from a straight to a semicircular form. It is expected that an engine will be equipped in the near future.

OTHER BUSINESS

Wm. C. Connelly, president of the American Boiler Manufacturers' Association, spoke briefly regarding the work which that association is doing in endeavoring to secure the adoption of a standard code for stationary boiler construction.

At the close of Tuesday's session, moving pictures of an educational nature were shown in the convention hall by the National Tube Company.

An invitation was extended to the association by E. W. Pratt, superintendent motive power and machinery, Chicago & North Western, on behalf of the American Railway Master Mechanics' Association, to send a representative to the convention of the latter association, at Atlantic City in June.

A report was presented on "The Best Rules to Follow in Arriving at the Maximum Heating Surface."

On Thursday the convention was addressed by J. T. Carroll, assistant general superintendent motive power of the Baltimore & Ohio, who spoke of the responsibility that all workmen should feel in the kind of work they turn out. In order that the best results may be obtained in this respect it is necessary that all instructions which are given be clear and that the men be properly equipped both with experience and tools.

L. R. Pyle, fuel supervisor, Minneapolis, St. Paul & Sault Ste Marie, called the attention of the association to the growing importance of the spark arrester problem because of laws being enacted in some of the states which seriously interfere with the operation of the locomotive. He urged that the association give this subject attention from the boiler maintenance standpoint in order that there might be reliable information on record for use in combating unreasonable legislation.

The secretary's report showed a membership of 426 at the opening of the convention, and during the convention 61 applications for membership were received. The treasurer reported that the total receipts during the year were \$1,130, with a balance on hand at the close of the fiscal year of \$553.88.

The following officers were elected for the ensuing year: President, D. A. Lucas, C. B. & Q., Havelock, Nebr.; first vice-president, John B. Tate, Penn. R. R., Altoona, Pa.; second vice-president, Charles P. Patrick, Erie, Cleveland, O.; third vice-president, Thomas Lewis, L. V., Sayre, Pa.; fourth vice-president, T. P. Madden, Mo. P., St. Louis, Mo.; fifth vice-president, E. W. Young, C. M. & St. P., Dubuque, Iowa; secretary, Harry D. Vought, New York City; treasurer, Frank Gray, C. & A., Bloomington, Ill. The following were elected members of the executive board to serve for three years: L. M. Stewart, Atlantic Coast Line, Waycross, Ga.; John Harthill, New York Central, Collinwood, O., and John Rapps, Illinois Central.

The retiring president, Andrew S. Greene, was elected to serve as the association's delegate to the convention of the American Railway Master Mechanics' Association.

OLD MAN FOR DRILLING SADDLE BOLTS

BY H. C. SPICER

The illustration shows an "old man," made of  $\frac{1}{2}$  in. by 2 in. flat iron, and used for drilling out saddle bolts and steam pipe studs. It can also be used for drilling new cylin-

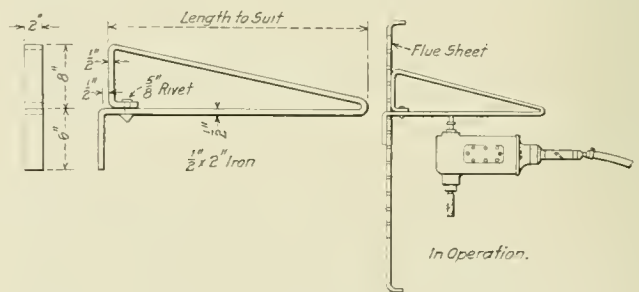

Old Man for Attachment to Tube Sheet

ders when they are being applied by placing it in a tube hole in the tube sheet at any angle or radius desired.

STEEL FOR GEARS.—For so-called "clash" gears, high-carbon tool steel is superior to casehardened machine steel. Gears made from the latter material are likely to have the hard case chipped off, thereby exposing the soft core to the impact of clashing.—*Machinery*.



# ENGINEHOUSE PRACTICE AT MACON, GA.

BY C. L. DICKERT

Assistant Master Mechanic, Central of Georgia, Macon, Ga.

The Central of Georgia has at Macon a 32-stall enginehouse, with 15 outside tracks, all work being done in the enginehouse, so that the workmen are kept out of the weather. All stalls have pits 3 ft. deep by 40 ft. long, which takes in the wheelbase of engine and tank. The pits are of concrete and are well drained and kept clean, so that the workmen can do their work without any inconvenience.

We have installed in the enginehouse a motor-driven drop table capable of removing all driving wheels and trucks from our largest engines at one time. There is very little of this work done, however, as the engines are taken care of in

drill, one driving box and rod bushing press, one cold saw, one power punch and shear, one power bending rolls, one bolt altering machine, one single head bolt cutter, one pipe threading machine, one cylinder packing ring saw, a blacksmith forge, a pipe brazing and bending oil furnace, and a tool room for all small tools. The machinery is motor driven.

A standard work bench with two vises is provided between each two pits. The benches have two swinging drawers of cast iron and two lockers in the bottom of the bench encased with wire netting, so that the inspection of the lockers can be made without calling on the workmen for their keys. There are 16-ft. jib cranes placed between every other two pits, equipped with one ton chain hoists and placed at a height to swing clear of smoke stacks. They reach both sides of an engine, making it convenient to remove smoke stacks, front end doors, pistons, etc.

All engines are inspected on their arrival and after all reports are worked up the same inspectors make another inspection before the engines leave the enginehouse for their run. This we find to be a very good practice, as we get a check on the workmen to see that all work reported has been done. Where the inspector finds work not done, or the work improperly done, he makes a report to the enginehouse foreman. The inspection pit is located on the approach to the turntable. All engines are stopped after passing over the

Form No. 1489 M. P. 1516

### CENTRAL GEORGIA RAILWAY COMPANY

#### DAILY LOCOMOTIVE INSPECTION AND REPAIR REPORT

Locomotive No. 1617  
Train No. 8  
Division Macon.

INSTRUCTIONS—Each Locomotive and tender must be inspected after each trip or day's work and report made on this form whether needing repairs or not. Proper explanation must be made hereon for failure to repair any defects reported, and the form approved by foreman before locomotive is returned to service.

Inspected at Macon, Ga. time 2:45 A.M. M. Date March 15th, 1916.

Locomotive is in good order with exception of following, which should be repaired.

(24) Pack Engine trucks  
(24) Left back driving box runs pretty hot, cellars do not seem to be feeding as they should

(15) Clean up headlight.

---

Does engine steam well? Yes If not, why?

Condition of injectors Good Water Glass Good  
Condition of gauge cocks Good Brakes Good  
Condition of piston rod packing Good Valve stem packing Good

Safety valve lifts at 200 lbs. Seats at 195 lbs.  
Main reservoir pressure 130 lbs. Brake pipe pressure 110 lbs.

Locomotive Failure. Give details of failure, cause of failure and number minutes lost  
" None "

---

Prod gates Poarch  
Name Fireman. Signature Inspector  
H. Swansburg Anderson  
Signature Engineer Signature Inspector

The above work has been performed except as noted and report is approved.

Frank Burch  
Foreman.

---

Inspector's Report (On Reverse Side of Sheet)  
(18)  
By Engine Inspector Poarch. P. Lift lever broken on Left Side, Right Grab iron to cab does not clear 2 1/2"  
(12)  
By Tender Inspector Anderson.....Nothing to report.

Fig. 1—Daily Locomotive Inspection and Repair Report

the back shop when all wheels are to be removed. All trucks are removed from engines when they are in need of repairs or lateral is to be taken up in the boxes. Repairs can be made in less time when the trucks are removed. We also have two single drop pits, air operated, for removing a single pair of drivers. On the outside of the enginehouse we have a drop pit, air operated, for removing and applying tender truck wheels.

The enginehouse machine shop has one 26-in. engine lathe, one 16-in. engine lathe, one 44-in. boring mill, one 32-in. stroke shaper, two drilling machines, one sensitive

5-10-15-2m hks. Brk. Co. 13011 FORM M. P. 81

### CENTRAL GEORGIA RAILWAY COMPANY

Workman #24 Locomotive Work Card No. 714

ENGINE NO.	ENGR., INSPECTOR, OR FOREMAN	PLACE, TIME, AND DATE
1617	Swansburg	3/15/16
<u>Pack Eng. trucks. Left back Driving box runs pretty hot, cellars don't seem to feed as they should.</u>		
<small>TIME AND DATE WORK COMPLETED</small>	<small>SIGNATURE WORKMAN</small>	<small>APPROVED</small>
	<u>T.H.S.</u>	

FOREMAN

Fig. 2—Locomotive Work Card

ashpit where the fire is knocked out and the boiler thoroughly blown out through the blow-off cocks. The inspection pit will accommodate two engines. Provisions are made to enter the pit from the outside, keeping inspectors from crawling between the wheels.

Fig. 1 shows the form of daily locomotive inspection and repair report. A supply of these forms is kept on a clip board in the enginemen's wash room, and after each trip or day's work the enginemen record the work to be done, as shown. These reports are gathered up by a messenger during the day and carried to the enginehouse foreman's office, where they are checked over by the foreman, and if any errors are discovered the engineman making out the report is notified in writing to call at the foreman's office and correct them. The foreman, when checking over reports, places the workman's number opposite the item he is to work up. These items are copied from this form to that shown in Fig. 2, a carbon copy being made on yellow paper. The original ticket is placed in a pigeon hole bearing the workman's number; the carbon copy is kept in the foreman's office. When the work has been completed the workman signs his name and turns the ticket, Fig. 2, into the foreman's office. The tickets for each day are matched up with the carbon or yellow ticket, according to ticket number, date and engine number. (The tickets are numbered, beginning on the first of each month with No. 1.) If the work is not done the workman makes a statement on the back of the ticket as to

why it was not, and signs his name on the back of the ticket.

After the work tickets are made out for repairs to be made, the work reports, Fig. 1, are placed on a clip board and kept in the office where the foreman can look after them during the day. The foreman and inspectors sign the reports each afternoon. The work tickets, Fig. 2, are pinned to the reports, Fig. 1, and the inspector writes up what he finds on the back of the report after checking up the tickets, and knows that all work reported by him has been done. Fig. 1 is filed in daily order and the work tickets, Fig. 2, are filed separately for each day. By this means we know what workman to blame should we have an engine failure due to poor workmanship.

Each workman who handles reports is given a shop number. A case with pigeon holes is located just outside of the foreman's office, and each pigeon hole is numbered to correspond with the workman's number. The work report, Fig. 2, is made out by a clerk, who places the forms in a rack where they are gotten out by the workmen during the day.

We also have placed on the outside of the foreman's office

CENTRAL GEORGIA RAILWAY COMPANY		FORM M P 88
MOTIVE POWER DEPARTMENT		
Engine	1413	Division <u>Chattanooga</u> To be shopped at <u>Macon</u> , Date <u>March 14 1916</u>
Class Repairs	4	Last Date General Repairs <u>3-2-14</u> 101
REPAIRS REQUIRED WITHIN 30 DAYS		
Boiler	Good	
Firebox	Good	
Flues	Good	Arch Pipes Good
Cylinders	Fair	Pistons and Rods Good
Valves	Fair	Crossheads and Guides Good
Eccentrics	Fair	Links Good
Injectors	Fair	
Air Pumps and Brakes	Fair	
Driving Wheel Centers	Fair	Tires 2" 6/32 thick 2/32" Wear
Driving Axles	Fair	Driving Boxes Fair
Shoes and Wedges	Fair	Driving Springs Good
Trailer Tires	None	Trailer Axles None
Trailer Wheel Centers	None	Trailer Boxes "
Rods	Good	
Crank Pins	"	
Steam Pipes	"	Throttle Good
Engine Truck	"	
Tender Trucks	"	
Tender Frame	Bad	
Tank	Good	
Blow Off Cocks	"	Safety Valves Good
Whistle	"	Bell Ringer None
Fire Door	"	Headlight Good
Engine Frames	"	
Cab	Fair	Running Boards Fair
Steam and Air Gauges	Good	Sander and Sand Box Good
Jacket	"	Lagging Good
Pilot	"	Pilot Sill Good
Miscellaneous	Engine 1413 out of service since Sept 1915.	

Fig. 3—Repair Report Furnished the Erecting Shop

a blackboard which is posted each morning showing what engines, freight and passenger, stand for every schedule during the day, so that the workman will know what engines are to be worked on first. We have regular men for working on passenger engines and the same for freight engines; also men assigned to dead work.

We have still another blackboard showing pit numbers. When an engine is placed in the enginehouse the hostler writes on the board the pit the engine is placed on and the time placed in the house, and signs his name. The same board has provisions for the hostler signing up for engines taken out of the house. The board is placed at the foreman's office where the foreman or workman can tell at a glance

just what pit each engine is on. This saves time in locating engines. Another board located at the same place shows the engines to be wiped, schedule, time, etc. A boiler wash board is also provided showing the engines due for washing; when the boilers have been washed a check mark is placed opposite the engine number. We have a hot water boiler washing system. The house is heated by hot air heating, supplied through a tunnel, with two openings in each pit, making good working conditions in cold weather.

Where the work tickets, Fig. 2, are made out by the day force and not worked up on engines to be used on night runs, the night foreman is furnished with these tickets to work up, and the same from night to day force.

When engines are to be shopped, the form in Fig. 3 is made out and furnished the erecting shop for each engine. This means of handling engines to be shopped enables the shop force to get up extra parts that need renewing and remedy some defects which, under ordinary conditions, would not be found while the engine is undergoing general repairs.

The organization includes a general enginehouse foreman, an enginehouse foreman day and night, an engine despatcher and a clerk, engine inspectors, day and night, safety appliance inspectors, an air brake inspector and boiler inspectors.

### MOLDING GASKETS FOR FEED VALVES

BY E. A. MURRAY

Master Mechanic, Chesapeake & Ohio, Clifton Forge, Va.

The drawing shows a simple mold for making lead gaskets for the feed valve connections of the engineer's brake valve, by the use of which we have been able to reduce the cost of these gaskets approximately 50 per cent. The mold is in

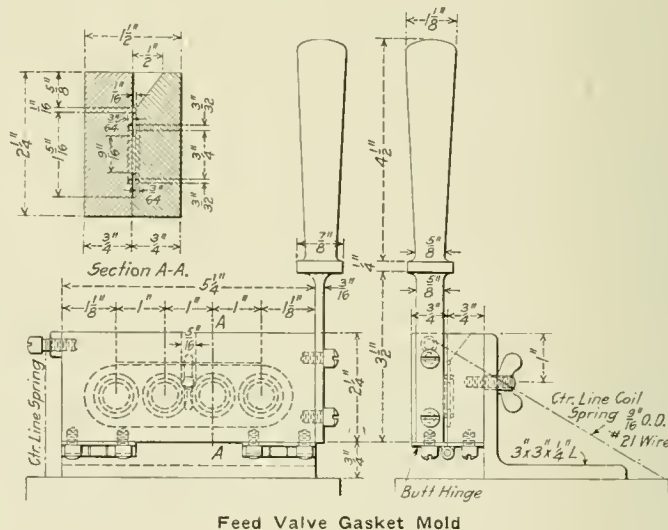

Feed Valve Gasket Mold

two parts, which are joined at the bottom by a butt hinge, and is mounted on the vertical face of a short piece of 3-in. angle bar. Normally the two parts of the mold are held in the closed position by a coil spring, the position of which is indicated in the drawing. A pouring gate 5-16 in. wide by 1/2 in. long at the top and tapering to the thickness of the gasket at the bottom is cut in the fixed half of the mold. The finished gaskets are removed by means of the handle attached to one end of the movable section of the mold.

**MAGNETIC CHUCKS.**—Magnetism for holding steel and iron parts for grinding, planing and turning operations has been made use of, especially for thin parts that are easily sprung out of shape by ordinary clamping means. Magnetic grinding, planing and lathe chucks have come into common use in plants having up-to-date equipment.—A. S. M. E. Journal.

### PIPE BENDING MACHINE

BY E. A. MURRAY

Master Mechanic, Chesapeake & Ohio, Clifton Forge, Va.

The pipe bending apparatus shown in the drawing consists of a heavy cast iron off-set face plate, to which is securely fastened an ordinary air brake cylinder. The piston of this cylinder actuates a crosshead, which is prepared to receive

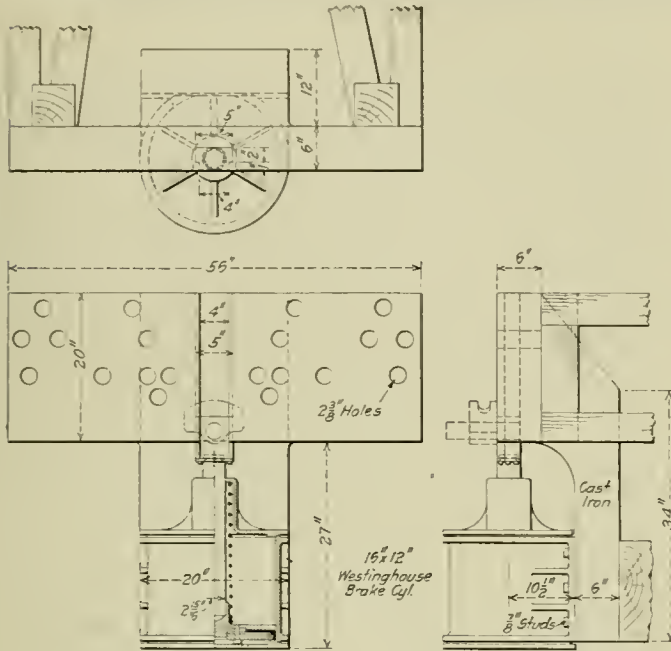

Apparatus for Bending Pipe

forms suitable for the different sizes of pipe generally used in locomotive practice. Pipe can be bent to any radius desired by the spacing of the pins in the face plate.

### JIG FOR TUBE CUTTERS

BY EDGAR BARNES

Tool Maker, Texas & New Orleans, Houston, Tex.

The drawing shows a jig for a milling machine, used on the Texas & New Orleans at Houston, Tex., for the rapid and uniform making of tube cutters. This jig was designed

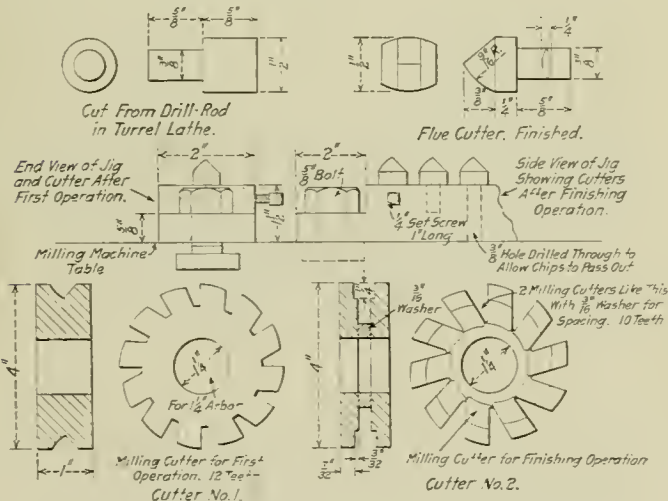

Jig for Making Tube Cutters on a Milling Machine

by F. C. Fantry, tool-room foreman. It is made of one piece of steel, 2 in. by 1 1/2 in. and of a length to suit the travel of the table. This piece is cut down at each end to allow the milling cutter to pass over, and 3/8-in. holes, equally spaced, are drilled for the tube cutters; 1/4-in. set screws are

used to hold the cutters in place. The jig will accommodate a number of cutters, according to the travel of the machine table. A 5/8-in. drill rod is used for making the cutters and only two operations on jig are required. After the first operation the cutters are turned 90 deg. and the second operation finishes them. This has proved to be a much cheaper and more efficient method than was formerly used here.

### CARBOY HOLDER

A simple inexpensive stand for a carboy, used in the locomotive paint shop of the Chicago & North Western at Clinton, Iowa, is shown in the accompanying illustration. It consists of a steel plate to which are bolted the supports for the frame holding the carboy. This frame is made up of small iron strips, one surrounding the carboy and two riveted to it and passing underneath forming a sort of basket. Two



Carboy Holder

pins are riveted to the circular strip which rest on the supports, thus permitting the carboy to be tipped for emptying. A wire passing around the neck of the carboy and held by two other wires extending from it to the strip surrounding the carboy prevents it from falling out when it is tilted to an extreme position.

### CARE OF BOILER TUBES

By JOSEPH SMITH

While the advent of the electric welder has aided in overcoming, to some extent, the trouble due to leaky tubes, we still have many cases arising. The scale that is formed on the end in the process of swaging is loosened in the process of expanding and as there is no avenue of escape, it remains between the tube and the copper ferrule and must be a great contributing factor to the leakage of tubes. Filing or otherwise cleaning the ends of tubes before applying will relieve this. In order to have a tight joint, we must have a clean, smooth joint.

The Prosser expander is a most useful tool, but care and good judgment should be exercised in its use. A tube can be expanded to such an extent as to reduce its elasticity, then there is no response to efforts to keep it tight. To substantiate the claim that this tool is abused I will cite an instance where a new tube sheet had been applied. It was carefully trammed just below the bottom tube at the center row and as near to the top flange as we could get. After the tubes were applied this distance was checked up, and was found to be greater by 3-16 in., showing that tubes and tube sheet had suffered by careless expanding.

# New Devices

## REFRIGERATOR CAR BRINE TANK VALVE

The dripping of the salt brine from refrigerator cars on the right-of-way is injurious to steel bridge construction, etc., and for this reason about two years ago, the Master Car Builders' Association ruled that all cars equipped with brine carrying tanks should also be equipped with a device for

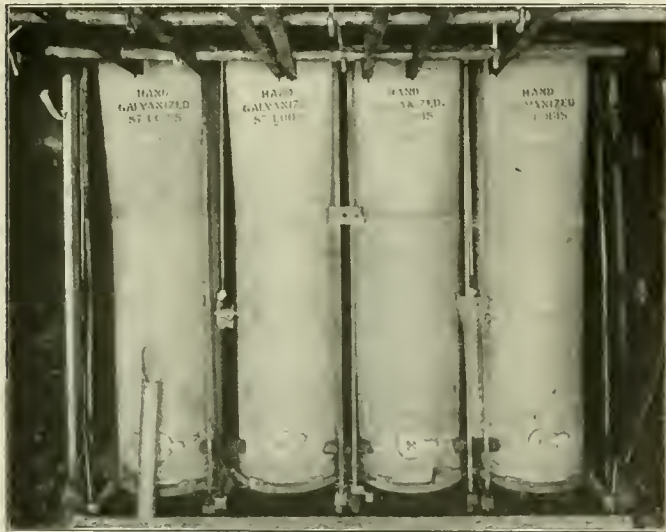

Ureco Brine Tank Valves Applied to a Beef Car

retaining the brine until the cars reached an icing station, or one of the plants of the packers, where the brine could be released and fresh brine put in the tanks.

After going into this matter thoroughly and making exhaustive tests, the Union Railway Equipment Company, McCormick Building, Chicago, has designed and placed in

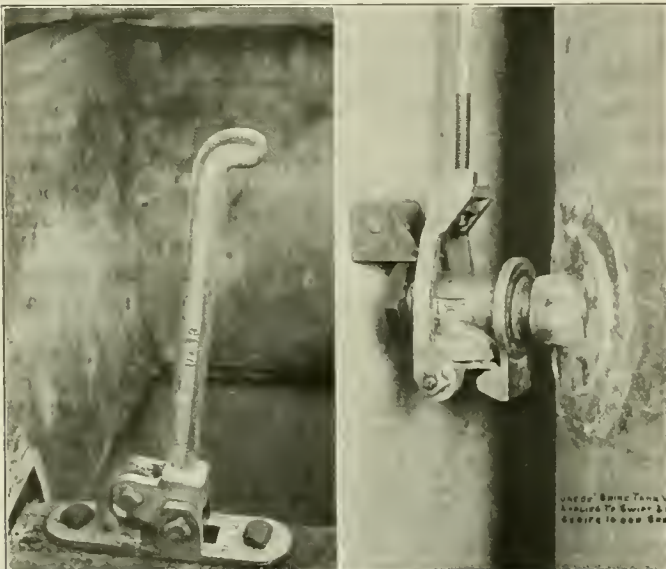

Operating Lever and Brine Tank Valve Applied to a Beef Car

service a device which accomplishes the results contemplated by the M. C. B. rule. This device is known as the Ureco brine tank valve and one of the illustrations shows the application to cars equipped with square tanks, one valve draining two tanks. The valve is operated with a lever in the hatchway and to open the valve requires only the raising of the lever to a vertical position. This moves the operating rod downward, opening the gate at the lower side of the valve, which allows the brine to drain freely through the downspout, or to the pan and thence out through the traps. When the valve is open and the lever in a vertical position, it prevents the application of the hatch-plug until the valve is closed, thereby insuring the closing of the valve before the car is again in transit. The operating rod is arranged with a square nut in the clevis operating the gate, so that any variation in the distance between the top of the partition between the tanks and the tank valve can be taken up and

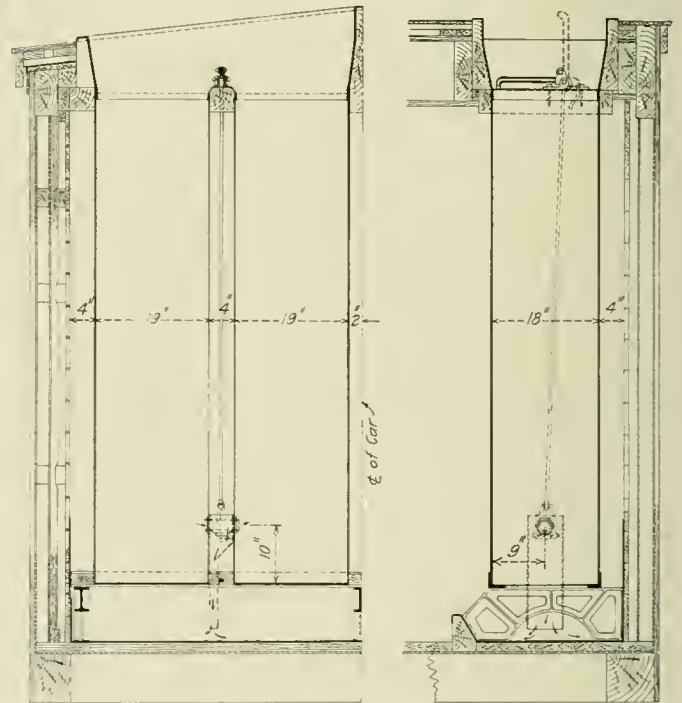

Details of Application of the Ureco Valve

retain a water-tight connection between the gate and the valve.

All parts of the mechanism are galvanized. The valve gate in closing brings in contact two rubber seats which make water-tight condition. Conducting the brine from the valve to the pan with the downspout prevents any possibility of splashing of the brine out onto the floor of the car. Included among the illustrations are some which show the application of the Ureco brine valve to a circular design of tank, the valve being located 30 in. from the bottom of the tank and the brine carried away with a circular downspout. The valve in this instance is applied with one blind end, the blind end being held in position by a small bracket on

the adjacent tank, all four tanks being connected at the bottoms with a flexible connection.

The valve can be applied to tanks of any description and requires but 4 in. spacing between the tanks. The construction is such that little attention is required to keep it in operation.

### A STEAM FLOW METER

The measurement of steam flow is one of the most difficult engineering problems that has ever been attempted. It resolves itself into two distinct parts: first, to obtain a pressure difference that varies in a known and definite manner with the rate of flow, and second, to accurately measure, record and integrate the rate of flow by means of this pressure difference. After a large amount of experimental work, in which a number of means of securing the required pressure difference were tried, the Bailey Meter Company, Boston, Mass., has developed a special type of orifice which has shown a constant accuracy over long periods. It has the additional advantages of low cost and ease of installation. The size of the orifice is properly proportioned to the size of the pipe and the meter capacity so that the Bailey standard recorder may be used from the highest to the lowest velocities without changing the piping in any way.

This meter works upon the principle of accurately measuring the pressure difference across an orifice placed between a pair of flanges in a pipe line, as shown in one of the illustrations. The special orifice plate is made of 1/32-in. Monel metal and is corrugated near its outer edge so that it forms its own gasket without any other packing and does not change the dimensions of the joint in any way. The size of the



Bailey Fluid Meter with Pressure and Temperature Recording Pens

orifice is proportioned to the size of the pipe, the quantity and density of steam or other fluid flowing through it, so that about one-half pound drop in pressure is secured at average rates of flow. With this small pressure drop no cutting action occurs and the orifice plate is entirely free from corrosion. Plates which have been removed after more than a year's constant service in high velocity steam lines are said to have shown no wear whatever.

A sectional view of an orifice installed in a horizontal pipe is shown in the drawing. This is of segment shape which

is used in high velocity work to secure the correct pressure difference without undue obstruction. Circular orifices of relatively smaller diameter are used for lower capacities. In such cases a small drain hole is located in the orifice plate at the bottom of a horizontal steam pipe to prevent any accumulation of water.

There are but two moving parts in the recording portion of this meter and they are not subjected to the direct action of the steam, hot gases or other fluid being metered. The pressure difference is applied to opposite sides of a special shaped bell sealed in mercury, which acts as a frictionless piston, using the buoyant action of the mercury on the walls

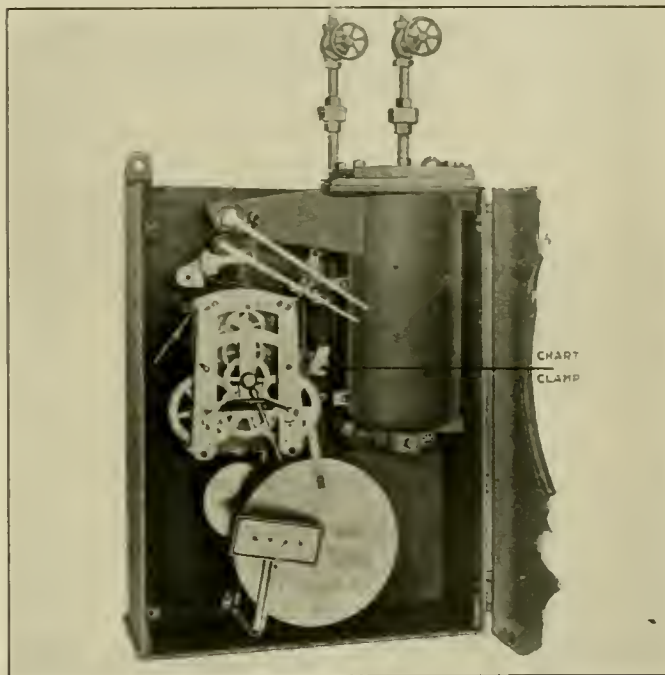

Interior of the Meter Showing the Bell Casing and Recording Mechanism

of the bell to balance the force due to the pressure difference. The bell has a variable cross sectional area so designed that the recorder gives a reading which varies in direct proportion to the rate of flow. Charts with uniform graduations are used and the records can be easily read and averaged or totaled with a radiometer. There are no springs, diaphragms, flexible connectors, etc., in the recorder.

When metering steam it is necessary to have the bell casing and connecting pipes completely filled with water up to an equal and constant level. Each time the bell rises or falls some water is drawn down in one pipe and an equal volume forced up in the other. It is practically impossible to have large enough reservoirs on a level with the steam pipe connections to answer this purpose, but the radiators shown in the drawing, consisting of a horizontal piece of half-inch copper pipe with a number of washers or fins, serve to maintain a uniform water level, and at substantially equal temperatures, in the two connecting pipes.

An extension of the bell casing contains the lever which operates the recording pen and integrator. One end of this lever is forked and engages two pins near the top of the bell; the other end is attached to a spindle which is given a rotary motion by the movements of the bell. This spindle has ends of small diameter which pass through pressure-tight bearings in the walls of the casing and to which are attached the pen and integrator arms. The packing is a thin disc of pliable material having a hole of the right diameter to make a practically frictionless joint which is free from leakage. The gland is so constructed that the packing is not

squeezed against the spindle when the nut is tightened.

The meter is provided with simple automatic shut-offs which prevent blowing out the mercury or otherwise damaging the apparatus when either of the pressures is excessive due to an abnormally high rate of flow, improper opening of the valves or even the breaking of one of the connecting pipes.

The counter is suspended from a knife-edge bearing on the clock frame and is moved across the disc by a connecting rod from an arm which projects down from the back end of the shaft carrying the recording pen. The follower wheel of the integrator is in frictional contact with the clock-driven disc and is moved from the center out toward the circumference as the rate of flow increases from zero to the maximum capacity of the meter. The follower wheel has a number of rollers on its circumference so as to cause practically no friction as it is moved across the disc, and also to prevent the aluminum disc from wearing smooth.

Perfect contact is said to be maintained between the wheel

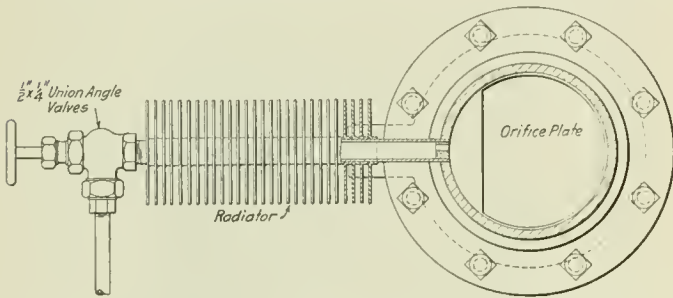

Sectional View of Pipe with Orifice Plate and Meter Connections

and disc at all times, regardless of vibration. This is accomplished by having the axis of the follower wheel almost perpendicular to the disc so that it bears on its projecting edge instead of its extreme outer circumference. The wheel is held in contact with the disc by a cantilever spring.

The meter may be provided with either or both pressure and temperature recording pens recording near the center of the chart and which are operated by the well known Bristol or Foxboro helical tubes, connected respectively to the arm of the bell-casing and a thermometer bulb in the steam line.

### ACME FOLDING TAIL GATE

The Acme Supply Company, Chicago, has placed on the market a new type of folding tail gate for passenger train

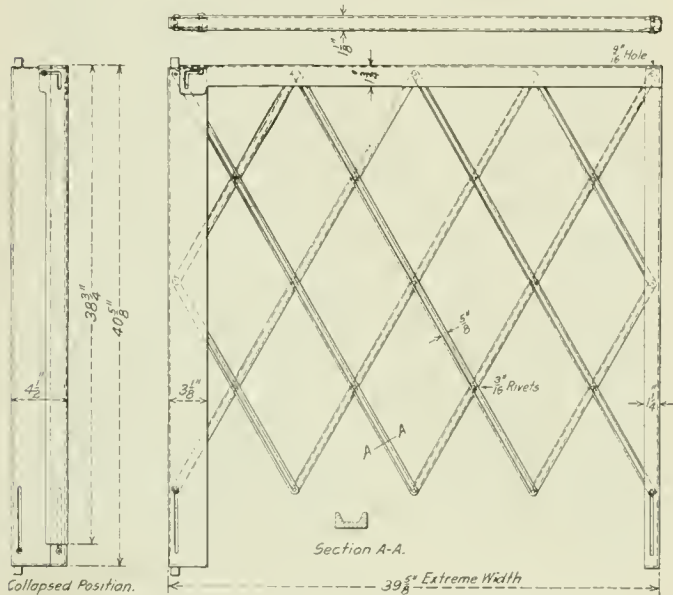

Folding Tail Gate In Open and Closed Positions

cars. This gate has several desirable features. It is light, strong and has a neat appearance in both the open and closed position. It is provided with a pressed steel housing at the left, a top guard rail which also forms a cover to the housing when the gate is folded, and a pressed steel end post. The lattice work is made of channel sections to give sufficient strength with minimum weight. When the gate is folded it is completely encased and can be folded against the vestibule diaphragm post allowing the vestibule curtain to be pulled into position, covering the tail gate from view when it is not in service. This design of gate has no projections and eliminates the possibility of the clothing of the passengers being caught. The gates are furnished with the necessary brackets and a brass plunger pull pin is provided for locking when in the service position. The gates can be made to interchange with the type of brackets now used on cars in service.

### WATER SOFTENER WITH INCREASED SETTLING SPACE

A water softening plant has recently been brought out by the L. M. Booth Company, New York, in which the relation of the softening chamber to the settling and storage tank has been changed to provide a maximum area of upward flow through the latter, facilitating the settling of the precipitate.

In the usual type of construction of these plants the softening tank extends down into the settling space through practically its entire depth, the water and chemical supply entering at the top and as it gradually flows downward being thoroughly stirred mechanically. On leaving the softening tank, at the bottom, the water gradually rises in the settling space while the precipitate collects at the bottom of the set-

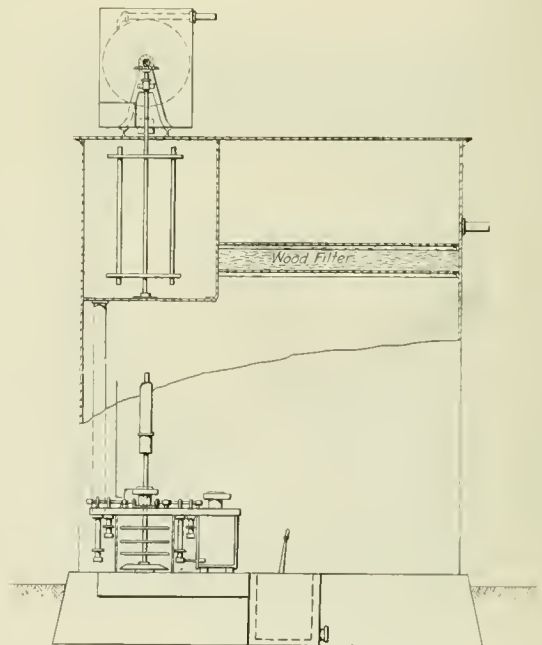

Booth Water Softener with Segmental Softening Chamber

tlng tank. With the softening tank thus located, the effective area of the settling space is considerably less than the total cross sectional area of the settling tank. Consequently the rate at which the water rises is faster than would be the case were the entire area available, and the settling of the precipitate is slower.

In the newly designed plant the softening tank occupies a segment of the storage tank near the top, thus leaving practically the entire area of the settling tank available for the upward flow of the water which is conveyed from the softening chamber through vertical pipes opening near the bottom of the settling tank.

# Railway Mechanical Engineer

(Formerly the RAILWAY AGE GAZETTE, MECHANICAL EDITION  
with which the AMERICAN ENGINEER was incorporated)

PUBLISHED ON THE FIRST THURSDAY OF EVERY MONTH BY THE  
SIMMONS-BOARDMAN PUBLISHING COMPANY

EDWARD A. SIMMONS, *President* L. B. SHERMAN, *Vice-President*  
HENRY LEE, *Vice-President and Treasurer* M. H. WIUM, *Secretary*  
WOOLWORTH BUILDING, NEW YORK, N. Y.

Chicago: Transportation Bldg. Cleveland: Citizens' Bldg.  
London: Queen Anne's Chambers, Westminster.

ROY V. WRIGHT, *Editor*  
A. C. LOUDON, *Managing Editor*

R. E. THAYER, *Associate Editor* C. B. PECK, *Associate Editor*

Entered at the Post Office at New York, N. Y., as mail matter of the  
second class.

Subscriptions, including the eight daily editions of the *Railway Age Gazette* published in June in connection with the annual conventions of the Master Car Builders' and American Railway Master Mechanics' Associations, payable in advance and postage free: United States, Canada and Mexico, \$2.00 a year; Foreign Countries (excepting daily editions), \$3.00 a year; Single Copy, 20 cents.

WE GUARANTEE, that of this issue 8,600 copies were printed; that of these 8,600 copies 7,601 were mailed to regular paid subscribers, 83 were provided for counter and news companies' sales, 410 were mailed to advertisers, exchanges and correspondents, and 506 were provided for new subscriptions, samples, copies lost in the mail and office use; that the total copies printed this year to date were 49,100, an average of 8,183 copies a month.

The RAILWAY MECHANICAL ENGINEER is a member of the Audit Bureau of Circulations.

VOLUME 90

JUNE, 1916

NUMBER 6

## CONTENTS

### EDITORIALS:

What Is Heat Treated Steel?.....	273
The Cleaning of Locomotives.....	273
Locomotive Repair Facilities and Costs.....	273
Convention Papers and Discussion.....	273
Dealing with Government Inspectors.....	273
Welding Tubes in the Back Tube Sheet.....	274
Air Brake Association Convention.....	274
Storekeepers' Association Convention.....	274
Railway Fuel Association Convention.....	275
Painting of Steel Freight Cars.....	275
New Books.....	275

### COMMUNICATIONS:

Leakage of Horizontal Sheathing.....	276
Tobesura Weno on Locomotive Inspection.....	276
A Correction.....	276
Apprenticeship in the Drawing Room.....	276
The Mechanical Department Clerk.....	276

### GENERAL:

Fuel Association Convention.....	277
Locomotive Impact Tests.....	288
Railway Storekeepers' Convention.....	290
Detentions from a New Angle.....	296

### CAR DEPARTMENT:

Terminal Cleaning of Passenger Cars.....	297
How to Keep Car Inspectors.....	298
Air Brake Association Convention.....	299
Cleaning Passenger Cars.....	304

How to Develop the Car Inspector.....	305
Dismantling of Cars.....	306
Holding Down Wheels While Changing Brasses.....	307
Smoke Jack for Passenger Cars.....	308
Hand Brakes on Mountain Grades.....	308

### SHOP PRACTICE:

Repairing Angle Cocks.....	309
Grinding Rod Packing Cone Rings.....	310
Steam Gage Testing Stand.....	310
Double Ring Tire Heater.....	310
Master Boiler Makers' Convention.....	311
Old Man for Drilling Saddle Bolts.....	318
Enginehouse Practice at Macon, Ga.....	319
Molding Gaskets for Feed Valves.....	320
Pipe Bending Machine.....	321
Carboy Holder.....	321
Care of Boiler Tubes.....	321

### NEW DEVICES:

Refrigerator Car Brine Tank Valve.....	322
A Steam Flow Meter.....	323
Water Softener with Increased Settling Space.....	324

### NEWS DEPARTMENT:

Notes.....	325
Meetings and Conventions.....	326
Personals.....	327
Supply Trade Notes.....	329
Catalogues.....	330

The steamers Massachusetts and Bunker Hill, of the Metropolitan Line, running between New York and Boston, now pass through the Cape Cod Canal, thus shortening their journey 77 miles. The Cape Cod canal, eight miles long, was opened two years ago, with a depth of water of 15 feet. One year ago it had a depth of 18 feet.

The London & North-Western has discontinued the running of restaurant and dining cars on its entire system of over 3,000 miles. The Great Western is taking off restaurant cars on the routes to Birmingham and the north, and it is supposed that other railway companies will also discontinue the use of dining cars on the ground of economy.

The Norfolk & Western has notified employees that, except where important interests of the company may interfere, anyone who wishes to take his vacation this year at Camp Oglethorpe, Ga., for military training, will be allowed a month off, with pay; this is an experiment to see how the matter works out. The company believes that large employers of men ought to encourage military training; but, of course, can reach no satisfactory conclusion until it is seen how many men desire to go to the camps. According to the Knoxville

Sentinel, somebody expects that 500 employees of the road will go to Fort Oglethorpe; but an officer of the company informs us that, for the May encampment, only two took advantage of the company's offer; one a man from the general office, and the other a conductor on the Norfolk division. There is to be another encampment in June.

## THE JUNE CONVENTIONS

The chairman of the entertainment committee of the Railway Supply Manufacturers' Association, Gilbert E. Ryder, Locomotive Superheater Company, New York, reports that arrangements are being made to re-establish the baseball game on Saturday afternoon. This year the teams will represent the two railroad associations; that is, the game will be played by teams representing respectively the Master Car Builders' and the Master Mechanics' associations. The teams are now being organized by M. C. M. Hatch, supervisor of fuel service of the Delaware, Lackawanna & Western, who will manage the Master Mechanics' team, and A. La Mar, master mechanic of the Pennsylvania Lines West, at Chicago, who will manage the Master Car Builders' team. Provisions are also being made for the best golf tournament

that the conventions have ever had. The arrangements are under the direct supervision of E. H. Bankard, Jr., Cambria Steel Company, Chicago, acting for the entertainment committee.

#### ORDERS FOR CARS AND LOCOMOTIVES IN MAY

The large buying of locomotives still continues, the orders for locomotives reported during May totaling 278, including 30 engines for export. The orders for freight and passenger cars reported during the month, on the other hand, were rather disappointing, orders for only 3,154 freight cars and 33 passenger cars for domestic service having been noticed. The totals for the month were as follows:

	Locomotives	Freight cars	Passenger cars
Domestic .....	248	3,154	33
Foreign .....	30	3,050	..
	278	6,204	33

Among the important locomotive orders were the following:

Road	No.	Type	Builder
Boston & Maine.....	25	Switching	American
	10	Consolidation	American
	10	Pacific	American
Canadian Government Rys.....	30	Mikado	Canadian
Denver & Rio Grande.....	10	Santa Fe	American
Maine Central .....	6	Mikado	American
	2	Switching	American
Pennsylvania (Lines East).....	75	Mikado	Baldwin
Seaboard Air Line.....	5	Mountain	American
Southern .....	6	Mikado	Lima
	8	Switching	Lima
Temiskaming & Northern Ontario.....	6	Mikado	Canadian
Terminal Ass'n of St. Louis.....	12	Switching	American
Paris-Lyons-Mediterranean (France) ...	20	Mikado	Baldwin

The freight car orders included 1,000 wooden box cars ordered by the Chicago & North Western from the American Car & Foundry Company. The Canadian Government Railways ordered 500 box cars from the Eastern Car Company and 500 from the Canadian Car & Foundry Company. The Louisville & Nashville has ordered its own shops to build 1,000 box, 500 gondola and 100 furniture cars.

Of the 33 passenger cars, 20 were ordered by the Norfolk & Western from Harlan & Hollingsworth Corporation. The order included 7 coaches, 6 baggage and express cars, 4 baggage and mail cars and 3 postal cars.

#### MONUMENT TO THE LEXINGTON & OHIO

F. Paul Anderson, dean of the College of Mechanical & Electrical Engineering of the State University of Kentucky, Lexington, announces that on Tuesday, May 30, the college proposes to dedicate at Lexington a monument to early American railroading; the monument to be in the shape of a section of the original track of the Lexington & Ohio Railroad, the first railroad built west of the Allegheny mountains. About 25 feet of the original track, made up of materials which have recently been unearthed, will be set in a concrete base on the campus of the university, and with it a bronze tablet bearing the following inscription:

This restoration of a portion of the original track of the Lexington and Ohio (now Louisville and Nashville) Railroad, laid at Lexington in 1831, is dedicated to those men of forethought and courage who were pioneers in railroad development in America.

Erected Anno Domini  
MCMXVI.

The sleepers of this track consisted of longitudinal stone "sills," and the rails were of wrought iron, half an inch thick, three inches wide and 14 feet long. The ends of the rails were miter jointed and were secured by spikes driven into lead-filled holes which had been drilled in the stone. Railroad officers and everybody interested will be welcomed at the dedication.

Professor V. E. Muncy has gathered a large amount of interesting history of the old railroad which is to be celebrated. The first stone sill was laid October 21, 1831, and the railroad was opened August 12, 1832. The cars were drawn by horses. In March, 1833, a length of six miles was in operation, and the "car, usually filled with passengers, was run regularly three times a day, each way." About this

time a steam locomotive, built by a Mr. Bruen, was in use; and on January 31, 1835, "an elegant new locomotive of improved model" was running between Lexington and Frankfort. About a year later, as appears from newspaper accounts, horses were again put in use for hauling the passenger cars, the locomotive being not sufficiently reliable for passenger service. It was, however, continued in use for hauling freight cars.

The average annual receipts of the road for passenger and freight transportation during four and one-half years, ending in 1847, were \$45,940; average annual profits, \$20,650.

#### MEETINGS AND CONVENTIONS

*Chief Interchange Car Inspector's and Car Foreman's Association.*—The annual convention of the Chief Interchange Car Inspector and Car Foreman's Association will be held in Indianapolis, Ind., October 3, 4 and 5, 1916.

*The Traveling Engineers' Association.*—The next annual convention of The Traveling Engineers' Association will be held on September 5-8, at Chicago, Ill. The following is a list of the subjects to be discussed at this meeting: Stoking and Lubricating, and Their Effect on the Cost of Locomotive Operation; Superheaters and Brick Arches on Large Locomotives; The Prevention of Smoke and Its Relation to the Cost of Fuel and Locomotive Repairs; Recommended Freight Train Practice; Assignment of Power from the Standpoints of Efficient Service and Economy in Fuel and Maintenance.

*American Society for Testing Materials.*—The nineteenth annual meeting of the American Society for Testing Materials will be held at Atlantic City, N. J., June 27 to 30. Headquarters for the meeting will be at the Hotel Traymore. A summarized program of the meeting follows:

*First session*, Tuesday, June 27, 11 a. m.—Minutes of eighteenth annual meeting; report of executive committee; various committee reports; announcement of election of officers; miscellaneous business.

*Second session*, Tuesday, 3 p. m.—Reports of committees on miscellaneous materials.

*Third session*, Tuesday, 8 p. m.—Presidential address and reports on heat treatment of steel.

*Fourth session*, Wednesday, 10 a. m.—Reports on steel and iron.

Wednesday afternoon will be reserved for recreation.

*Fifth session*, Wednesday, 8 p. m.—Reports on tests and testing.

*Sixth session*, Thursday, 10 a. m.—Reports on cement and concrete.

*Seventh session*, Thursday, 3 p. m.—Reports on ceramics and road materials.

Thursday evening will be reserved for a smoker.

*Eighth session*, Friday, 10 a. m.—Reports on non-ferrous metals and cast iron.

*Ninth session*, Friday, 3 p. m.—Reports on miscellaneous materials.

The nominating committee has agreed to the following selections: For president, A. A. Stevenson; for vice-president, S. S. Voorhees; for members of the executive committee, W. H. Bassett, John Brunner, G. W. Thompson and F. E. Turneaure.

*The M. C. B. and M. M. Conventions.*—The program of the convention of the Master Car Builders' Association at Atlantic City, beginning June 14, includes the presentation of committee reports of the standing committees on Arbitration, Standards and Recommended Practice; Train Brake and Signal Equipment; Brake Shoe and Brake Beam Equipment; Couplers; Loading Rules; Car Wheels; Safety Appliances; Car Construction, and Specifications and Tests for Materials. Reports will be received from the special committees on Car Trucks; Prices for Labor and Material; Train Lighting and Equipment; Tank Cars; Settlement.



Prices for Reinforced Wooden Cars; Draft Gear, and Welding of Truck Side Frames and Bolsters.

At the convention of the Master Mechanics' Association, beginning June 19, committee reports will be presented by the standing committees on Standards and Recommended Practice; Mechanical Stokers, and Fuel Economy and Smoke Prevention; and by the special committees on Design and Maintenance of Locomotive Boilers; Locomotive Headlights; Superheater Locomotives; Equalization of Long Locomotives; Dimensions of Flange and Screw Couplings for Injectors; Design, Maintenance and Operation of Electric Rolling Stock; Best Designs and Materials for Pistons, Valves, Rings and Bushings; Co-operation with Other Mechanical Organizations; Powdered Fuel; Specifications and Tests for Materials; Train Resistance and Tonnage Rating, and Modernizing of Existing Locomotives.

The chairman of the entertainment committee of the Railway Supply Manufacturers' Association announces that euchre parties for the ladies will be held Thursday and Tuesday. The ladies' committees in charge have Mrs. D. R. McBain as chairman the first week, and Mrs. E. W. Pratt as chairman for the second week. Prizes will be offered. Players will be identified by their badge numbers.

The president of the Railway Supply Manufacturers' Association, Oscar F. Ostby, announces that the executive office of the association will be opened on the pier May 29, at which time certain spaces will be ready for the installation of exhibits. According to official circular No. 2, exhibit booths will be ready for occupancy as follows: Exhibition Hall, May 29; under west balcony of Main Building, June 9; all others June 6, except spaces on runways used for trucking, which spaces will be available in ample time. The pier authorities have advised that preparations are progressing excellently, and that everything will be ready four or five days in advance. All exhibitors are urged to get their exhibits on the way as soon as possible, so that there may be no danger of delay because of the freight congestion.

*The following list gives names of secretaries, dates of next or regular meetings and places of meeting of mechanical associations:*

- AIR BRAKE ASSOCIATION.—F. M. Nellis, Room 3014, 165 Broadway, New York City.
- AMERICAN RAILROAD MASTER TINNERS', COPPERSMITHS' AND PIPEFITTERS' ASSOCIATION.—W. E. Jones, C. & N. W., 3814 Fulton St., Chicago.
- AMERICAN RAILWAY MASTER MECHANICS' ASSOCIATION.—J. W. Taylor, Karpen Building, Chicago. Convention, June 19, 1916, Atlantic City, N. J.
- AMERICAN RAILWAY TOOL FOREMEN'S ASSOCIATION.—Owen D. Kinsey, Illinois Central, Chicago. Convention, August 24-26, 1916.
- AMERICAN SOCIETY FOR TESTING MATERIALS.—Prof. E. Marburg, University of Pennsylvania, Philadelphia, Pa. Convention, June 27-30, Traymore Hotel, Atlantic City, N. J.
- AMERICAN SOCIETY OF MECHANICAL ENGINEERS.—Calvin W. Rice, 29 W. Thirty-ninth St., New York.
- ASSOCIATION OF RAILWAY ELECTRICAL ENGINEERS.—Joseph A. Andreucetti, C. & N. W., Room 411, C. & N. W. Station, Chicago. Semi-annual meeting, Hotel Denis, Atlantic City, N. J., June 16.
- CAR FOREMEN'S ASSOCIATION OF CHICAGO.—Aaron Kline, 841 Lawlor Ave., Chicago. Second Monday in month, except June, July and August, Hotel La Salle, Chicago.
- CHIEF INTERCHANGE CAR INSPECTORS' AND CAR FOREMEN'S ASSOCIATION.—W. R. McMunn, New York Central, Albany, N. Y. Convention, October 3-5, Indianapolis, Ind.
- INTERNATIONAL RAILWAY FUEL ASSOCIATION.—J. G. Crawford, 547 W. Jackson Blvd., Chicago.
- INTERNATIONAL RAILWAY GENERAL FOREMEN'S ASSOCIATION.—William Hall, 1126 W. Broadway, Winona, Minn. Convention, August 29-31, 1916, Hotel Sherman, Chicago.
- INTERNATIONAL RAILROAD MASTER BLACKSMITHS' ASSOCIATION.—A. L. Woodworth, Lima, Ohio. Convention, August 15-17, 1916, Hotel Sherman, Chicago.
- MASTER BOILER MAKERS' ASSOCIATION.—Harry D. Vought, 95 Liberty St., New York.
- MASTER CAR BUILDERS' ASSOCIATION.—J. W. Taylor, Karpen Building, Chicago. Convention, June 14, 1916, Atlantic City, N. J.
- MASTER CAR AND LOCOMOTIVE PAINTERS' ASSOCIATION OF U. S. AND CANADA.—A. P. Dane, B. & M., Reading Mass. Convention, September 12-14, 1916, "The Breakers," Atlantic City, N. J.
- NIAGARA FRONTIER CAR MEN'S ASSOCIATION.—E. Frankenberger, 623 Brisbane Building, Buffalo, N. Y. Meetings, third Wednesday in month, New York Telephone Bldg., Buffalo, N. Y.
- RAILWAY STOREKEEPERS' ASSOCIATION.—J. P. Murphy, Box C, Collinwood, Ohio.
- TRAVELING ENGINEERS' ASSOCIATION.—W. O. Thompson, N. Y. C. R. R., Cleveland, Ohio. Convention, September 5-8, 1916, Chicago.

## PERSONAL

### GENERAL

C. D. BARRETT has been appointed assistant engineer of motive power of the Pennsylvania Railroad at Altoona, Pa. Mr. Barrett was born on January 25, 1881, and graduated from Purdue University in 1901. He entered the service of the Pennsylvania Railroad in July, 1901, as special apprentice at Altoona, Pa. In March, 1905, he was appointed inspector in the machine shop and later in that year was transferred to Jersey City, N. J., in the same capacity. In May, 1907, he was appointed assistant master mechanic at Camden, N. J., and in April, 1908, he returned to Jersey City as inspector. He was promoted to foreman at State Line, Pa., in November, 1908, and in April, 1909, was made assistant master mechanic at Wilmington, Del. In May, 1911, he was promoted to assistant engineer of motive power at Williamsport, Pa., which position he held at the time of his recent appointment at Altoona, as noted above.

H. H. MAXFIELD, whose appointment to the position of superintendent of motive power of the Western Pennsylvania division of the Pennsylvania Railroad was announced in



H. H. Maxfield

our last issue, has been in the service of the Pennsylvania Railroad since 1895, and a master mechanic on the Pittsburgh division since 1905. He was born in 1873 and was educated at Stevens' Institute. He entered the service of the Pennsylvania Railroad September 5, 1895. He became a machinist August 1, 1899, and March 1, 1900, became inspector or gang leader. On April 1, 1901, he was appointed assistant road foreman of engines, becoming successively on Decem-

ber 1, 1902, assistant master mechanic, and on April 15, 1903, assistant engineer of motive power. On April 1, 1905, he became master mechanic of the Pittsburgh division, and it is this position he now leaves to take up his new duties as superintendent of motive power of the Western Pennsylvania division, with office at Pittsburgh.

H. D. CAMERON, whose appointment as mechanical engineer of the Canadian Northern, with office at Toronto, Ont., was announced in our May issue, was born on September 23, 1879, at Toronto, and was educated in Montreal public and high schools, and in 1901 graduated from McGill University with the degree of B. S. He began railway work in the summer of 1899, as a mechanical apprentice at the Grand Trunk shops, Montreal, Que., and continued in shop work during vacations and after graduation until 1902. He subsequently worked for about one year in the mechanical department drawing office at Ottawa, Ont., of the Canada Atlantic, now a part of the Grand Trunk. From 1903 to 1905 he was assistant engineer of the Montreal Water & Power Company, and then joined the engineering staff of the Gulf, Colorado & Santa Fe at Cleburne, Tex. In 1906 he returned to Canada and entered the service of the Canadian Northern in the mechanical department at Winnipeg, and in April, 1916, was transferred to Toronto as mechanical engineer of the same road, as above noted.

L. B. JONES has been appointed assistant engineer of

motive power of the Central division of the Pennsylvania Railroad at Williamsport, Pa. Mr. Jones was born in September, 1882, at West Grove, Pa. He graduated from Cornell University in 1904, and entered the service of the Pennsylvania Lines West as a special apprentice in July of that year. He was made locomotive fireman in November, 1906, and in February, 1907, became enginehouse foreman at Logansport, Ind. He was appointed assistant electrician at Columbus, Ohio, in July, 1908, and in March, 1910, was made electrician of the Vandalia Railroad. In February, 1911, he was made inspector at Columbus, Ohio, and in January, 1913, was promoted to assistant engineer of motive power of the Central system, Lines West, and was transferred to the Southwest system in the same capacity in June, 1915, which position he held at the time of his recent appointment as noted above.

THOMAS LEWIS, whose appointment as general boiler inspector of the Lehigh Valley at Sayre, Pa., was announced in our May issue, was employed respectively by the Chicago & Alton, Bloomington, Ill.; Vandalia, Terre Haute, Ind.; Chicago & North Western, Chicago, and for five years was assistant foreman boiler maker of the Union Pacific at Omaha, Neb. He entered the service of the Lehigh Valley as general boiler foreman of the shops at Sayre, Pa., in January, 1907, and was promoted to general foreman in October, 1912. He was made master mechanic of the Auburn division in January, 1916, and was promoted to general boiler inspector in April last.

#### MASTER MECHANICS AND ROAD FOREMEN OF ENGINES

ROBERT G. BENNETT has been appointed assistant master mechanic of the Cumberland Valley at Chambersburg, Pa. Mr. Bennett entered the service of the Pennsylvania Railroad as an apprentice in the Erie, Pa., shops in January, 1900, and in 1902 was transferred to the Renovo shops where he completed his course in 1904. He then entered Purdue University, taking the course in mechanical engineering, from which he graduated in 1908 and received his degree of mechanical engineer in 1915. In 1908 he was appointed motive power inspector of the Monongahela division of the Pennsylvania and was made rodman in the maintenance of way department of the Pittsburgh division in 1912. He was transferred to the test department at Altoona as inspector in 1913, which position he held up to the time of his recent appointment as assistant master mechanic of the Cumberland Valley, as noted above.

A. BROWN, formerly district master mechanic of the Canadian Pacific at Winnipeg, has been appointed district master mechanic, district 1, British Columbia division, at Revelstoke, B. C., succeeding W. J. Renix, transferred.

M. G. CHARLES, master mechanic of the Oregon Electric and the United Railways, at Portland, Ore., has had his jurisdiction extended over the Portland division of the Spokane, Portland & Seattle.

T. H. HAMILTON has been appointed district master mechanic, districts 1, 3 and 4, Ontario division of the Canadian Pacific at Toronto, Ont., succeeding G. I. Evans.

FREDERICK W. HANKINS, who has recently been appointed master mechanic of the Cumberland Valley at Chambersburg, Pa., was born on January 1, 1876, at London, England. Mr. Hankins was educated in the public schools of Foxburg, Pa., and entered the service of the Pittsburgh & Western, then part of the Baltimore & Ohio, as machinist apprentice in April, 1891. He was transferred to the Baltimore & Ohio at Allegheny, Pa., in 1894, and in July, 1897, entered the employ of the Allegheny Valley at the Forty-third street shops in Pittsburgh, Pa., where he served successively as machinist, leading machinist, and acting roundhouse fore-

man until April, 1905, when he was transferred to the Cumberland Valley as enginehouse foreman at Chambersburg, Pa. In January, 1907, he was appointed machine shop foreman at Chambersburg, Pa., and in December, 1910, was promoted to general foreman of the Chambersburg shops, which position he held until his new appointment as master mechanic, as noted above.

J. M. KERWIN has been appointed master mechanic of the Dakota division of the Chicago, Rock Island & Pacific, with office at Estherville, Iowa, succeeding W. B. Embury, transferred.

T. F. PHELAN has been appointed road foreman of equipment of the Chicago, Rock Island & Pacific at Herington, Kan., succeeding B. J. Bonner, transferred.

CHARLES D. PORTER has been appointed master mechanic of the Pennsylvania Railroad at Pittsburgh, Pa. Mr. Porter was born on February 7, 1883, at Fort Wayne, Ind., and graduated from Purdue University in 1902. In July, 1900, he entered the service of the Pennsylvania Lines West, and in July, 1902, was made special apprentice. He was appointed motive power inspector at Buffalo in June, 1906, and was made enginehouse foreman at Driftwood in August, 1908. In April, 1909, he was appointed foreman of the Mifflin shops and in October of that year was transferred to the Park shops, remaining there until January, 1912, when he was promoted to assistant general foreman of the Pitcairn car shops. He was made assistant master mechanic at Pittsburgh in December, 1912, and was appointed assistant engineer of motive power at Altoona in July, 1913, which position he held until May, 1916, when he was promoted to master mechanic at Pittsburgh.

W. J. RENIX, formerly district master mechanic, district 1, British Columbia division of the Canadian Pacific at Revelstoke, has been appointed district master mechanic at Moose Jaw, Sask.

F. W. SADLIER, formerly shop foreman of the Canadian Pacific at Revelstoke, B. C., has been appointed district master mechanic at Fort William, Ont., succeeding G. Twist, transferred.

G. TWIST, formerly district master mechanic of the Canadian Pacific at Fort William, Ont., has been appointed district master mechanic at Winnipeg, succeeding A. Brown, transferred.

#### CAR DEPARTMENT

W. H. LONG, formerly car foreman of the Canadian Northern at Trenton, Ont., has been appointed general car foreman of the Ontario division at Toronto, Ont.

C. N. McMATH has been appointed car inspector of the Grand Trunk Pacific at Transcona, Man., succeeding N. C. Hooper.

#### SHOP AND ENGINE HOUSE

W. J. BARBER, formerly acting locomotive foreman of the Canadian Pacific at North Bend, B. C., has been appointed locomotive foreman at Revelstoke, B. C., succeeding F. D. Warner, transferred.

N. B. CORBETT has been appointed shop superintendent of the Missouri, Kansas & Texas, at Denison, Tex., succeeding B. C. Nicholson.

R. A. HUEY has been appointed general locomotive foreman of the Chicago, Rock Island & Pacific at Armourdale, Kan.

G. C. GIBSON, formerly locomotive foreman of the Canadian Pacific at Strathcona, Alta., has been appointed locomotive foreman at Saskatoon, Sask., succeeding C. A. Perry, transferred.

J. W. JACKSON, formerly locomotive foreman of the Canadian Pacific at Rogers Pass, B. C., has been appointed locomotive foreman at Kamloops, B. C., succeeding John Macrae.

JAMES MCGOWN, JR., formerly machinist of the Canadian Pacific, has been appointed locomotive foreman at Rogers Pass, B. C., succeeding J. W. Jackson, transferred.

R. A. MCPHERSON has been appointed locomotive foreman of the Canadian Pacific at Ignace, Ont., succeeding A. J. Pentland, transferred.

A. W. MARTIN has been appointed superintendent of shops of the Cleveland, Cincinnati, Chicago & St. Louis, at Beech Grove, Ind., succeeding R. J. Williams, resigned.

S. E. MUELLER has been appointed general foreman locomotive shops of the Chicago, Rock Island & Pacific at Cedar Rapids, Iowa, succeeding J. M. Kerwin, promoted.

J. D. MUIR, formerly locomotive foreman of the Canadian Pacific at Medicine Hat, Alta., has been appointed locomotive foreman at Winnipeg, succeeding G. Pratt, transferred.

A. J. PENTLAND, formerly locomotive foreman of the Canadian Pacific at Ignace, Ont., has been appointed locomotive foreman at Souris, Man., succeeding H. J. Reed, transferred.

C. A. PERRY, formerly locomotive foreman of the Canadian Pacific at Saskatoon, Sask., has been appointed locomotive foreman at Medicine Hat, Alta., succeeding J. D. Muir, transferred.

G. PRATT, formerly locomotive foreman of the Canadian Pacific at Winnipeg, Man., has been appointed locomotive foreman at Strathcona, Alta., succeeding G. C. Gibson, transferred.

R. QUINN, formerly in Winnipeg shops of the Canadian Pacific, has been appointed shop foreman at Revelstoke, B. C., succeeding F. W. Sadlier, transferred.

J. A. REID, formerly locomotive foreman of the Canadian Pacific at Souris, Man., has been appointed locomotive foreman at Cranbrook, B. C., succeeding D. G. MacDonald.

JOHN R. SWINDELL has been appointed superintendent of the Wyoming Shops of the Pere Marquette at Grand Rapids, Mich., succeeding C. S. Williams, resigned.

F. D. WARNER, formerly locomotive foreman of the Canadian Pacific at Revelstoke, B. C., has been appointed locomotive foreman at Nelson, B. C., succeeding W. Pitts.

F. L. WILLIS has been appointed night locomotive foreman of the Canadian Northern at Dauphin, Man.

#### PURCHASING AND STOREKEEPING

SAMUEL WILSON SAYE, recently appointed purchasing agent of the Georgia & Florida, with headquarters at Augusta, Ga., was born on August 4, 1893, at Athens, Ga. He was educated in the grammar schools and later took a commercial course; then for two years received private instruction at Augusta. On January 8, 1912, he began railway work as a stenographer on the Southern Railway at Columbia, S. C. The following April he entered the service of the Georgia & Florida as a stenographer in the accounting department, and three months later he became secretary to the general manager. On February 1, 1916, he was appointed commercial agent, with headquarters at Vidalia, Ga., which position he held at the time of his recent appointment as purchasing agent of the same road at Augusta.

R. O. WOODS has been appointed division storekeeper of the Mobile & Ohio, with office at Meridian, Miss., succeeding M. R. Ducey, resigned to accept service with another company.

## SUPPLY TRADE NOTES

The Acme Supply Company has removed its general sales offices to larger quarters located at 1110-1113 Steger building, Chicago.

The Goldschmidt Thermit Company, New York, has moved its offices from 90 West street to the Equitable building, 120 Broadway.

C. F. Schroeder, treasurer of the Schroeder Head Light Company, Evansville, Ind., was killed in the railroad accident at New Decatur, Ala., on Saturday, May 6.

The Southern Locomotive Valve Gear Company, Knoxville, Tenn., has recently put on the market a new power reverse gear known as the Brown power reverse gear.

The general offices of the Standard Heat & Ventilation Company in New York have been removed to rooms 1504 and 1505 in the City Investing building, at 165 Broadway.

Sherritt & Stoer Company, Inc., 603 Finance building, Philadelphia, have been appointed the exclusive sales agents of the Gardner Machine Company for the Philadelphia district.

H. L. Breckenridge, for the past three years purchasing agent of the American Locomotive Company at Montreal, has been appointed purchasing agent of the Lima Locomotive Corporation, Lima, Ohio.

J. L. Adams, sales representative of the Cambria Steel Company, at Cincinnati, Ohio, has been appointed manager of sales of the Cambria Steel Company, the Midvale Steel Company and Worth Brothers Company.

William E. Eastman, inventor of the Eastman system for heating freight cars, and the founder and president of the Eastman Car Company, Charlestown, Mass., died at his home in Winchester, Mass., on May 15, at the age of 75 years.

The Terry Steam Turbine Company, Hartford, Conn., announces the appointment of O. E. Thomas, 626 Washington building, Los Angeles, Cal., as district sales manager for a territory covering Arizona and the southern portions of California and Nevada.

J. H. McDonald, chief clerk to the superintendent of telegraph of the Pennsylvania Railroad at Philadelphia, has resigned from that position to accept the position of superintendent of transportation of the Bethlehem Steel Company, with office at Steelton, Pa.

Henry C. Hammack has been elected secretary and treasurer of the Lima Locomotive Corporation, Lima, Ohio, to succeed John H. Guess, who recently resigned. Mr. Hammack has been with the company for eighteen years, having served as general and field manager and assistant secretary.

F. L. Fay, formerly general manager of the Greenville Steel Car Company, has been elected president and now has the controlling interest in the business. James G. Dimmick is vice-president and will have charge of the production department and factory management. The company is enlarging its plant to handle more business.

The Modern Tool Company, Erie, Pa., will hereafter devote its attention to its line of self-contained internal plain and universal grinding machines. It has sold its overhead counter-shaft line of plain, internal and universal grinders to Albert J. Ott, Chicago, Ill., who will manufacture and market these machines under the name of the Ott grinders.

C. J. Wymer, general car foreman of the Belt Railway of Chicago, has resigned that position to enter the employ of the Grip Nut Company as sales agent. Mr. Wymer was born in Jane Lew, W. Va., and after leaving school served his

apprenticeship with the West Virginia & Pittsburgh, now a part of the Baltimore & Ohio system. He entered the employ of the mechanical department of the Atchison, Topeka & Santa Fe at Raton, N. M., in September, 1896. He was promoted to car foreman at Trinidad, Colo., in 1898, where he remained until 1907, when he was appointed general car foreman of the Chicago & Eastern Illinois at Danville, Ill. In 1908 he came to Chicago, Ill., to become general car foreman of the Belt.

E. T. Sawyer, who has been associated with the Commercial Acetylene Railway Light & Signal Company for over eight years, has resigned to accept a position as sales engineer with the Edison Storage Battery Company. Mr. Sawyer from about 1901 to 1904 was with the western office of the Dressel Railway Lamp Works, of New York, and the Star Brass Manufacturing Company, of Boston. He later spent four years in the employ of the Acme Ball Bearing Company as manager of the railway department. His first three years in the employ of the Commercial Acetylene Railway Light & Signal Company were spent as southern manager. For the last five years he has been connected with the main office at New York.

Clifford J. Ellis, recently appointed manager of sales of the Midvale Steel Company at Chicago, has been in the employ of the Cambria Steel Company, formerly the Cambria Iron Company, for over 37 years, starting at the Johnstown (Pa.) office in 1879. In 1885, he was transferred to the Philadelphia office with the title of general agent. In that capacity he not only had charge of the sale of steel rails throughout the country but had direct supervision of the entire sales of the New York office. In September, 1886, he was transferred to Chicago, as manager of sales, in charge of the sale of all the company's products. As manager of sales of the Midvale Steel Company he will handle the business of that company and its recently acquired subsidiaries, Cambria Steel Company and Worth Brothers Company. His headquarters will be at 458 McCormick building.



Clifford J. Ellis

John B. Kilpatrick, vice-president of the Universal Arch Company, Chicago, Ill., died in that city on May 14. Mr. Kilpatrick was born at Philadelphia, Pa., on August 9, 1862, and was educated in Baltimore, Md. He entered the service of the Chicago, Rock Island & Pacific, in 1889, as general foreman at Fairbury, Neb. From 1890 to 1893, he was general foreman of the Colorado division at Goodland, Kans. From 1893 to 1902, he was master mechanic of the Iowa division, at Valley Junction, Iowa. He was stationed at Horton, Kans., as master mechanic from 1902 to 1903, when he was appointed assistant superintendent of motive power, with office at Chicago, Ill. From 1904 to 1912, he was superintendent of motive power at Chicago, and from April 1, 1912, to August 15, 1913, was district mechanical superintendent at Davenport, Iowa, and at Des Moines. From 1913 up to the date of his death he was engaged in the railway supply business, having been elected vice-president and director of the Universal Arch Company, Chicago, on April 1, 1916.

## CATALOGUES

**ELECTRIC GRINDERS.**—The Chicago Pneumatic Tool Company has recently issued Bulletin E-39, descriptive of the company's line of Duntley electric grinders.

**STEEL.**—The Vanadium-Alloys Steel Company, Latrobe, Pa., has recently issued two folders descriptive respectively of the company's Vasco non-shrinkable tool steel and its Vasco choice tool steel.

**DRAWING MATERIALS.**—Kolesch & Co., 138 Fulton street, New York, have issued a folder descriptive of the Security tube for protecting and storing blue print paper, tracing paper and cloth and drawing paper.

**HIGH-SPEED STEEL.**—The Vanadium-Alloys Steel Company, Pittsburgh, Pa., has recently issued a new folder which describes the company's Red Cut Superior high-speed steel. The pamphlet offers suggestions concerning heat treatment.

**THE BRINELL METER.**—Herman A. Holz, New York, has issued a ten-page booklet describing the Brinell meter for determining the hardness of metals. The book is illustrated with photographs of the testing outfit, and describes the method of operation in detail.

**WHARTON SPECIALTIES.**—William Wharton, Jr., & Co., Easton, Pa., have issued Bulletin No. 2, describing W-J switch stands, Wharton-O'Brien insulated switch rods and adjustable switch crank, and an insulated gage rod. The descriptions of the various devices are illustrated.

**GASOLINE HOISTS.**—The Lidgerwood Manufacturing Company has issued Bulletin No. 16, illustrating and describing a line of hoists operated by gasolene engines. These hoists are intended for use where electric current is not obtainable, and where coal and water suitable for boiler use are difficult to obtain.

**BUILDING MATERIALS.**—E. M. Long & Sons, Cadiz, Ohio, have issued an attractive 24-page booklet describing their lumber and other products, including O. G. fir gutters used extensively on railway buildings. The book is well illustrated with a large number of photographs showing various sections of their plant and their products.

**PORTABLE CRANES.**—The Canton Foundry & Machine Company, Canton, Ohio, has issued a booklet illustrating and describing the company's line of portable floor cranes and hoists. These cranes are so made that they can lift heavy loads and transfer them to or from lathes, planers or other machines, one man with a crane often being able to do work that would require four or more men without a crane. The cranes are in use in railroad shops for handling cylinder heads, steam chests, car wheels, large castings, etc.

**TRANSVEYORS.**—The Cowan Truck Company, Holyoke, Mass., has issued a booklet describing and illustrating the Cowan transveyor or elevating truck. In transferring material by means of these trucks, the material to be moved having been piled on low platforms is transported without rehandling or repiling, or, as the catalogue puts it, the Cowan transveyors "make the floor move." The booklet shows clearly how the trucks are used, by means of a number of views of trucks in use in various kinds of warehouses and shops.

**OIL ENGINES.**—Fairbanks, Morse & Co., Chicago, have recently issued Bulletins H 178 B and H 192 C, dealing respectively with the Fairbanks-Morse horizontal pattern Type "Y" (Semi-Diesel) oil engine and the company's Type "Y" oil engines, style "V." These engines are made in sizes 10 hp. to 25 hp. horizontal, and 37½ hp. vertical. They burn nearly all of the grades of fuel oil available, and with almost as great economy as the Diesel type of engine. They are simpler in construction and in operation, and lower in first cost. They are adapted for pumping, lighting and power service, and particularly for isolated lighting service.

# Railway Mechanical Engineer

Volume 90

July, 1916

No. 7

## Automatic Fire Doors

In the days when the old swing type fire door was in general use, while it was customary to keep the door closed between shovelfuls, it was not generally

known to what extent the cooling action of the air rushing through this opening affected the firebox temperature. The cold air streaming into the firebox not only lowered the temperature of the products of combustion and the sheets near the rear end of the firebox, but it struck the tube sheet in such a way as to result in leaky tubes and frequently in engine failures. The brick arch has done much to prevent this cold air getting to the tube sheet but the automatic door accomplishes a great deal by keeping a considerable amount of it from getting into the firebox at all. Of course, it is impossible with hand firing to keep the fire door closed all the time but the automatic door reduces the cooling effect to a very great extent because of its requiring the opening of the door for a much smaller period of time for each scoop of coal than with the old swing door. In addition, a feature which should not be overlooked is that of the added safety provided by the automatic door in case of a burst tube or any other accident which causes an accumulation of pressure in the firebox. There are records of a great many instances of enginemen being saved from severe scalding due to the use of the automatic door.

## Saving Oil and Wasting Fuel

"I am willing to use an extra five cents' worth of oil to save a dollar's worth of coal." This statement was made by the mechanical superintendent

of a large eastern road in discussing the report of the Committee on Superheater Locomotives at the June convention of the American Railway Master Mechanics' Association. How many other railway mechanical men consider the oil and fuel problems in conjunction in this way? Not very many, judging from the mania for reducing oil consumption that is so general. It is quite right to economize in every way possible—only, see that the economy is real and not false. There are too many roads that are tending to a reversal of the conditions—burning a dollar's worth of coal to save five cents' worth of oil. Proper lubrication of valves and cylinders prevents cutting and consequent blowing; a very slight falling off from the needed amount of oil will frequently be the means of valve and piston leakage that will send no inconsiderable amount of live steam directly into the exhaust passage and out the stack. The steam that escapes thus is an absolute waste, but what is still worse, the coal that was burned in making it into steam is also wasted. By all means stick to the practice of getting every possible economical engine mile from a pint of valve oil—but always be sure that it is economical. The waste in fuel is not the only waste that results from insufficient lubrication; there is extra wear and tear on other parts of the locomotive that causes increased maintenance charges. But if the lubrication is well enough taken care of to prevent in-

creased fuel consumption, such other troubles will be remedied, and the fuel consideration is therefore an excellent one to keep in mind when there is any temptation to cut oil allowances too fine.

## The Weight of Steel Freight Cars

There does not seem to be the same amount of objection raised that there was a few years ago to the weight of steel freight cars reaching figures as high as 48,000 and 50,000 lb. It is probable that the car designers are gradually getting the higher officers educated to the idea that a reasonable amount of weight must be placed in a steel car if it is to have ample strength. While there are still too many of the flimsily built type of car being turned out, a great many railroads, following the lead of one or two of the larger ones, seem to have come to the conclusion that it is better to haul a slightly heavier dead weight than to build a car that is all that could be desired as far as lightness is concerned, but which spends a large proportion of its life on the repair tracks. This is one of the numerous matters in railroad work that require careful consideration to arrive at the correct balance between increased operating costs due to heavier cars and increased maintenance costs due to cheaply built cars. Of course, there is a point beyond which dead weight should not be permitted to go, and it is the work of the designer to keep from going beyond this point, i.e., to provide a car with maximum strength and the least possible dead weight consistent with this.

## How Can the Car Designer Improve?

In the April issue a competition was announced in which prizes of ten dollars each were offered for the three letters offering the best suggestions as to how improvements in car design might be effected. This competition closed June 1, 1916, and on another page in this issue will be found the three prize-winning letters. These were submitted by C. H. Faris, Benson, Neb.; Charles E. Wood, foreman freight car repairs, Union Pacific, Kansas City, Kan., and Dennistoun Wood, Palo Alto, Cal. It is worthy of note that the point most frequently touched on in the letters submitted is the lack of a sufficiently close relation between the designer, the transportation department and the car repair forces. The need of co-operation between these three organizations is self-evident; yet there seems to be considerable difficulty in the way of bringing about a satisfactory relationship which will work toward that end. The plan outlined in one of the three letters appearing in this issue, whereby the various members of the drafting room force are more or less regularly to be brought into personal touch with the repair forces and given an opportunity to study defects in design at first hand, is worthy of careful consideration. The time thus spent by the designer away from the drawing-table will be more than repaid by the

clearer appreciation of, and the increased ability to cope with, certain phases of the problem of designing new equipment which are now too often overlooked.

#### Mechanical Stokers and Fuel Economy

In the discussion of the report on mechanical stokers at the convention of the Master Mechanics' Association last month it was stated that the mechanical stoker is not a fuel saver. So far as is known, the claim of economy in fuel has never been made for this machine; on the contrary, it has been stated by some of the manufacturers that they realize that it does not save fuel. The stoker does, however, increase locomotive capacity and provide a means of attaining the full boiler capacity on locomotives of a size on which this could not be obtained by hand firing. That it is accomplishing this in a satisfactory manner is evident from the statement, also made at the convention, that there is record of 30 stokers firing 30 locomotives an aggregate of 1,000,000 miles without a single case of failure. Because the mechanical stoker is not now a fuel saver, however, it does not necessarily follow that it may not be in the future. The machine has now been developed to a point where it is performing exacting service in a very satisfactory manner, and the probability is that the manufacturers are now in a position to work more along the lines of refinements such as would probably be necessary to produce an actual saving in fuel consumption. With the actual perfecting of the stoker, as far as ability to do its work is concerned, accomplished so well, there seems no doubt that the ability which has overcome all obstacles so far will continue improvements tending toward a still better and more economical machine.

#### Superheated Steam in Switching Locomotives

Evidence is not lacking that the railroads have begun to appreciate the value of the use of superheated steam in switching locomotives. There are now in service over 800 switch engines which are equipped with superheaters, and at a conservative estimate, 75 per cent of those now on order are to be so equipped. So far as we know the first application of superheaters to this type of locomotive was made several years ago to a locomotive on the Lake Shore and Michigan Southern, now the New York Central, and the results of tests of this engine were so satisfactory that several other roads purchased switch engines with superheaters. It is not surprising that the results have been so satisfactory when it is considered that because of the excessive cylinder condensation in saturated steam switch engines the rate of water consumption runs as high as 50 and sometimes 70 lb. per indicated horsepower hour, so that it is easy to believe that if the application of the superheater did nothing more than effect a material reduction in cylinder condensation with a consequent lowering of the water rate, the resultant saving in fuel would justify the additional investment. The reduction in the water rate means a consequent reduction in the number of times the tender has to be refilled, with a similar reduction in the amount of time which the engine is out of service in moving to and from the water tank. Furthermore, the saving in fuel means less fuel passing through the firebox and it is therefore possible to go longer without cleaning the fire. It may be said that as the engine crew has to stop for meals, the fire can be cleaned at that time, but when traffic is congested it frequently takes an engine several hours to get its turn over a congested cinder pit, so that if it is possible to do without having the fire cleaned it is evident that a considerable increase in the working time of the engine in times of heavy traffic can be obtained. It has been abundantly demonstrated that the work in any given

yard can be accomplished with a smaller number of superheater engines than would be required if saturated steam engines were used. In other words, a given switching capacity is obtainable with a smaller investment for power, if superheater engines are used.

#### The Cost of Locomotive Maintenance

Complaints are heard continually about the increasing cost of maintaining locomotives. In some of these complaints specific reference is made to some device which, while increasing the locomotive's economy, is of such a nature that it is expensive to maintain. The trouble with some of our railway men is that they expect something for nothing. When any new and important development is made in the locomotive, unless it can be conclusively shown that the maintenance charges are not going to be increased by its use they at once condemn it. No piece of machinery can reasonably be expected to run without being properly maintained and the trouble in a great many cases is that railway men do not grasp the proper balance between the resulting improved operation of the locomotive and whatever increase in maintenance expense there may be. A great deal has been made of the saying that anything applied to a locomotive must be fool proof and undoubtedly the greatest possible simplicity is desirable because of the working and repair conditions which obtain in locomotive practice. But if all mechanical department officers fully realize the benefits which the operating department is receiving from many of the special features of present day locomotives, they should not object to a reasonable increase in maintenance costs nor to bringing their roundhouse practice up to a higher standard in order to take proper care of these devices so that their full possibilities may be realized.

#### Can You Do This?

Many car and motive power departments are now giving attention to the problem of recruiting their ranks and offering some sort of training for apprentices. Even on the very few roads which are doing really good work in this respect, however, there are many mechanics and skilled and unskilled workers who have passed beyond the stage when they can take advantage of such instruction, but who still desire further to perfect themselves in the calling which they have chosen, and to fit themselves for promotion. Some day the railroads generally are surely going to awaken to the necessity of helping these men by advice and by planning courses of instruction for them. Meanwhile they are being played upon right and left by all sorts of fake schemes advocated by unscrupulous, glib-tongued solicitors, who get as much money as they can from the men, with big promises of what they will do for them. Then, even though in some cases the material which they give them is good, they leave them to themselves and provide little or no incentive or encouragement for them to follow up the courses for which they may have enrolled. In some cases the courses which are offered are all very good, but are sold to men who cannot possibly take advantage of them and ought never to have been urged to take them up. Where can the men go for advice when they are approached with a proposition of this kind? Ought not the railroads to assume the responsibility of giving them honest, wholesome advice as to where they can get the most for their money, at least until such time as the railroads themselves can individually supervise the developing and planning of educational courses for all of their men? What these men are usually after is concrete data which can be practically applied to their own problems, and there are few agencies which are prepared to offer such courses of study to the different classes of men in the car

and locomotive department. Responsible officers of each road ought to investigate these agencies and see that they give the men a square deal.

**Four-Wheel Trucks for Passenger Cars**

The steel day coaches of the Boston & Maine, described in another part of this issue, are mounted on trucks of the four-wheel type, thus placing this road

in the list of those whose officers believe that six-wheel trucks are not necessary under modern steel coaches. The Pennsylvania Railroad has for years used four-wheel trucks as standard under its 70-ft. steel coaches, weighing practically the same as those of the Boston & Maine, while the Philadelphia & Reading is operating trucks of this type under steel coaches in its fastest service. There does not seem any good reason why four-wheel trucks should not give entire satisfaction under steel coaches, considering the matter from the standpoints of safety, smoothness of riding and cost of maintenance; and when the cost of conducting transportation is considered, there is a very good argument against the six-wheel truck in its additional weight. A reasonable figure for the extra weight per car due to six-wheel trucks is 15,000 lb., so that in the case of the Boston & Maine cars, if six-wheel trucks were substituted for those of the four-wheel type, the additional weight in an eight-car train would be 120,000 lb., or equivalent to slightly more than the weight of another car. In other words, considering any given division on which a locomotive can haul eight cars fitted with six-wheel trucks, the same locomotive can haul nine such cars if they are mounted on four-wheel trucks. As the cost of maintenance of trucks of the six-wheel type is probably 50 per cent greater than that of four-wheel trucks, the latter type would seem to be preferable for use under passenger equipment cars, where the light weight of the body does not exceed that of the ordinary day coach.

**Lateral Motion Driving Boxes and Side Play**

In his address at the opening session of the convention of the Master Mechanics' Association, President Pratt said: "There is great promise in the

floating axle scheme, or some development of it, although it may require a change in the restricted side play now permitted by Federal rule and agreement." The floating axle referred to is the means of increasing the flexibility of driving wheelbase which is now employed on a large number of locomotives, the first ones equipped being the 2-10-2 type engines for the New York, Ontario & Western. It is felt, however, that this reference in the president's address may lead to misapprehension and possibly result in railway men raising a question as to the possibility of the lateral motion driving axle running contrary to the Interstate Commerce Commission's requirements. In order to correct any such impression there is given below paragraph 40 of the order of the Commission, dated October 11, 1915, which deals with lateral motion:

The total lateral motion or play between the hubs of the wheels and the boxes on any pair of wheels shall not exceed the following limits:

For engine truck wheels (trucks with swing centers).....	1 in.
For engine truck wheels (trucks with rigid centers).....	1 1/2 in.
For trailing truck wheels.....	1 in.
For driving wheels (more than one pair).....	0.54 in.

These limits may be increased on locomotives operating on track where the curvature exceeds 20 deg. when it can be shown that conditions require additional lateral motion.

The lateral motion shall in all cases be kept within such limits that the driving wheels, rods, or crank pins will not interfere with other parts of the locomotive.

From the foregoing it is evident that the order clearly defines that the lateral motion or play shall be measured between the hubs of the wheels and the boxes. On the lateral motion driving axle the play between the boxes and the

wheel hubs is kept at a normal figure. On many of the designs arrangements have been made for a take-up of lateral wear so that the side play may easily be kept at any desired amount without removing the wheels and boxes from the locomotive. All the lateral motion boxes have been so arranged that there is ample clearance between driving wheels, rods and crank pins and other parts. It should be evident, therefore, from what has been said and from the quotation from the Commission's order, that there is a likelihood of any ruling on the part of its inspectors which would prevent the use of this type of axle.

**NEW BOOKS**

*Mechanical Engineers' Handbook.* Lionel S. Marks, professor of mechanical engineering, Harvard University and Massachusetts Institute of Technology, editor-in-chief. Bound in morocco. 1,836 pages. 4 1/2 in. by 7 in. Illustrated. Published by the McGraw-Hill Book Company, Inc., 239 West 39th street, New York. Price, \$5.00 net.

The field of mechanical engineering has become so extended that it is no longer possible for a single individual, or a small group of individuals, to have sufficiently intimate acquaintance with all its branches to permit a satisfactory exercise of critical judgment in the statement of current practice and the selection of engineering data. The only existing reference work for mechanical engineers, compiled by a large group of specialists, is the three-volume German book "Hütte," now in its twenty-second edition. This book, however, includes civil and electrical engineering, as well as mechanical engineering. It has been continually improved for over fifty years, and is now the accepted authority within its range of topics. This work has been used as the basis for the new handbook. In only a few of the more theoretical sections, however, has the "Hütte" been followed at all closely. The greater part of the book, however, particularly those portions which deal with engineering practice, is wholly new.

The subject matter groups itself into two main divisions, the first 860 pages being devoted to the more theoretical topics and the last 960 pages to the statement and discussion of current practice. The first portion is divided into seven sections as follows: Mathematical Tables and Weights and Measures; Mathematics; Mechanics of Solids and Liquids (including Friction); Heat; Strength of Materials; Materials of Engineering; and Machine Elements. The portion treating of practice is divided into eight sections dealing with Power Generation; Hoisting and Conveying; Transportation; Building Construction and Equipment; Machine Shop Practice; Pumps and Compressors; and Engineering Measurements, Mechanical Refrigeration, etc. The total list of contributors numbers 50 specialists, each of whom is qualified to speak authoritatively on the subject assigned to him. In order to further increase the accuracy of data and to insure that the subject matter is not solely the practice of an individual, but is truly representative, a number of the contributions which deal with engineering practice were submitted by the editor-in-chief to one or more other specialists for their criticism before finally being incorporated in the handbook.

This book is the most thorough and comprehensive mechanical engineers' handbook adapted to American practice, if not in the English language, and its usefulness is considerably enhanced by certain features of the make-up. Both the front and back covers contain an index to major topics and a list of the more important tables is given on each fly-leaf. The book is provided with thumb tabs so that the reader, after looking at the index on the covers and finding there the section number, may turn immediately, by use of the thumb tabs, to the section in which he is interested. The important reference tables have the page reference so that they can be turned to immediately. The index is unusually complete and well arranged.

## COMMUNICATIONS

### HORIZONTAL SHEATHING FOR BOX CARS

CHICAGO, Ill.

TO THE EDITOR:

I have noted the suggestion for a new type of joint for horizontally sheathed box cars which appears in the *Railway Mechanical Engineer* for June, page 276. For the one purpose which was suggested, the change would probably be effective. Reference to the accompanying sketches, however, throws another light on the matter. In the sketches *A* represents the joint when the boards were new and *B* when they have shrunk to some extent. It will be noticed that *B* opens

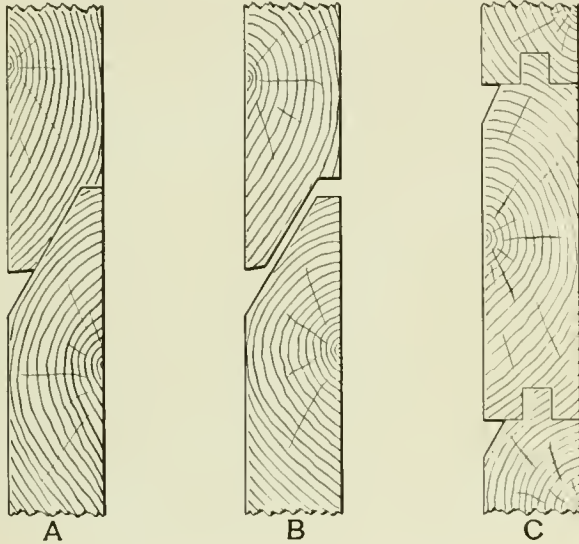

Horizontal Sheathing for Box Cars

a passage from the interior to the exterior of the car which is practically unobstructed. This would render this joint useless for grain cars. The other sketch which I have marked *C* shows the standard M. C. B. section for 1½-in. sheathing for this type of car. In this the only change I would suggest is as shown in the sketch, namely, the beveling of the upper outer edge of the board. This will, I believe, take care of any possible condition of this kind. W. E. FOWLER,

President, Fowler Car Co.

### MORE FROM TOBESURA WENO

(With apologies to Wallace Irwin)

CHICAGO, Ill.

Dear editor:

As I report in previous letter aforesaid as honorable colleague Brandeis, associate supreme court justice-elect would emit, I am become U. S. Federal I. C. C. detector. Of late, when I was watchful waiting on obscure rr. locomotive, I were beset by large member brotherhood as follows:

"Say, guinea" (exact epitaph used—dictionary explain kind of fowl) "guess you know where the kale comes from, what?" I reply I not familiar with sandhouse joke and are representing U. S. government. "Oh yes, he retort, legally, technically like Cliffie Thorne represent Hon. Commission of Iowa—but I mean you are become wise to who keeps you in job." I have no response and he reply—"It's us—we're the boys what produces fat bonanzas for such as you. So you want to come across with the goods and put bed springs and cushions on these ornery hogs." He continue a little submerged as foreman approach—"You see those windows—as dirty as them in my old woman's kitchen and glimpse the clinkers on the running board; behold the dent in the stack; feel the greasy handrail, look at the coal in the gangway, the

raggedy storm curtain. And would you believe it, cold water squirt nowadays. How's a man gonna wash up in icewater? Why can't the fireboy have a foot-rest and a back cushion too?" He also suggest a washbowl and mirror. I hastily apologize for unsanitary predicament, promise to confer with Chief Detector in Washington and escape on rear self-serve ashpan bracket. On account of recent arbitration hearing, I report—"Dent in smoke stack, right back corner; cab window too dirty for safety and squirt pipe bad design and require new hose." It are also remarked "that boiler dirty and require paint, hinge loose on tool-box, one sand pipe behind rear driver instead of in front, oil can leaky, headlight require more Standard oil, and air pressure too much in bell as it completely revolve."

I stop then as I have soft heart for railroad sometime and can get remains next time. Yours truly,

TOBESURA WENO.

### COLLEGE MEN IN THE MECHANICAL DEPARTMENT

PHILADELPHIA, PA.

TO THE EDITOR:

Your editorial on "College Men in the Mechanical Department," in the *Daily Railway Age Gazette* of June 22 was received with many feelings of an old friend.

It is my belief that the railway mechanical departments can get all the college men they want, and even all that they need. If a college graduate looks for a place with the railroad he is likely told that the chief is out on the road and it would be best for him to write; if he writes he is fortunate to receive a reply which states that there is no opening; and if he has the good fortune to see the man himself the answer is almost certain to be "Sorry, but we have nothing for you. I would advise you to try something else."

Some time ago I was working alongside the locomotive designer of a large eastern road. He had served his time as a machinist and was also a university man. The salary he received was about what a good man could earn at the machinist trade. I wished to call his attention to something bearing on a problem that he was then working on. "John," I said, "have you read this week's *Railway Age Gazette*? There is an article that might interest you." "What is it on? Why college men leave the railroad?" was his answer. Thus had the iron burned his soul.

Again, there is my own case. I went to work in the railway repair shop as a boy and after a year went to college. I completed the course successfully, during the summer vacations working in a nearby roundhouse. After graduation I held a couple of odd jobs for a while, and then went to work as special apprentice for a large railroad. The agreed length of apprenticeship went by, but it seemed to make no difference in my status. Finally I got restless and started to make inquiries as to my future. The replies did not measure up as satisfactory, so one day I got tired of waiting, took the day off and secured a position with a manufacturing concern. The next day I told the man I was working for that I would soon be leaving. "I shall be sorry to lose your services. Wait and I will see what I can do for you." So in the goodness of his heart he went and saw the superintendent of motive power, who told him that he could raise my wages to a point that would almost equal what I would have been receiving some years before had I finished serving my time as machinist. I was tired of butting my head against a stone wall and faded from the railroad service.

I cannot see where there lies any value in the suggestion that the railroads pick out men and send them to college. Unless the railroads experience a great change of heart these would only do as so many of us before them have done: work a while, notice that the opportunities outside were greater, get tired of charging their efforts to experience, and go out into the world to make a real living.

GEORGE S. CLOUSER.



# WHAT IS HEAT TREATED STEEL?

Discussion of Its Production and Use; First Prize  
Article in the Competition Which Closed May 1

BY LAWFORD H. FRY

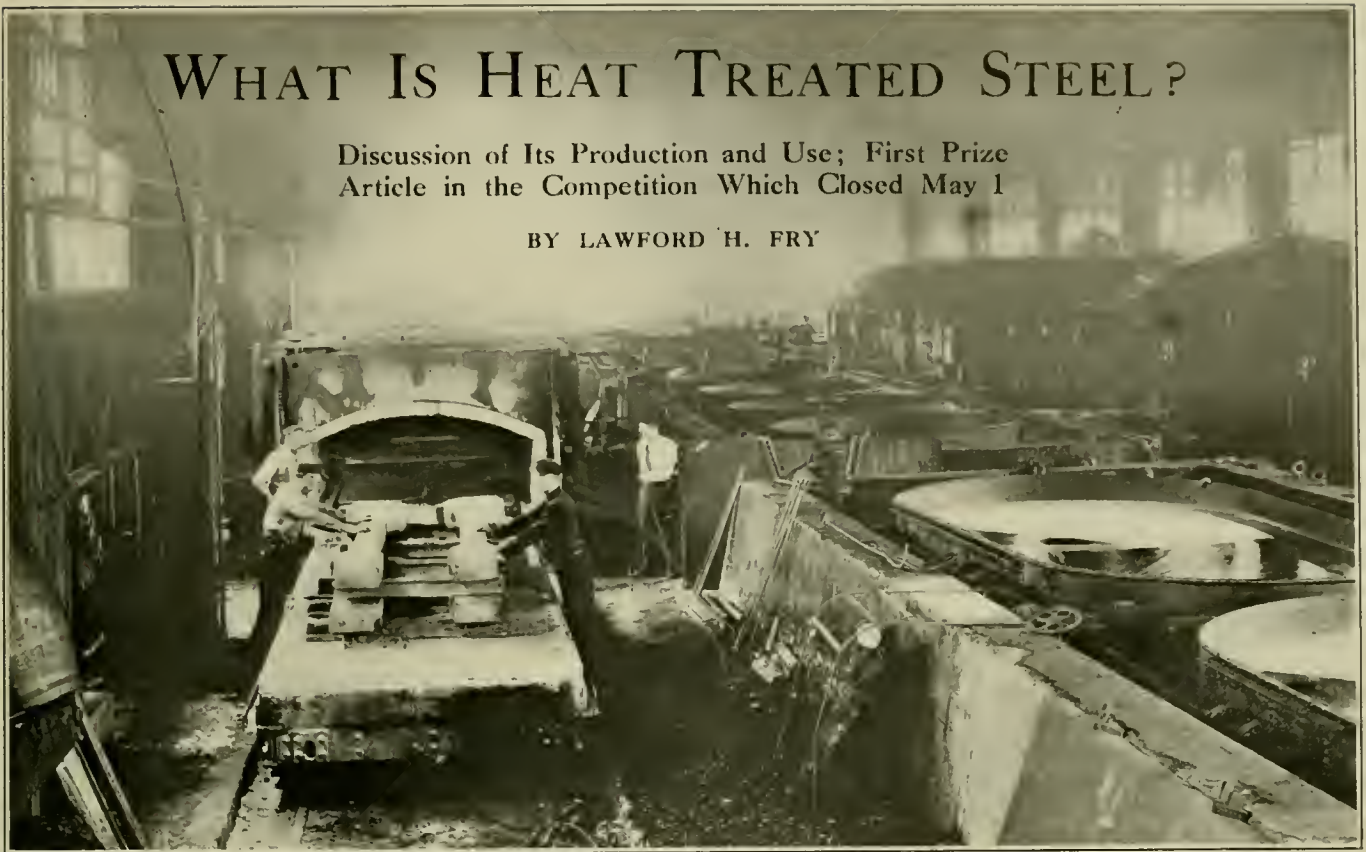

Heat Treating Plant, Standard Steel Works Company, Burnham, Pa.

Heat treatment is much like strong medicine. Applied by a skilled doctor under proper conditions, it gives excellent results, but in unskilled hands the consequences are disastrous. In fact, after reviewing some of the early unhappy examples of heat treatment one might well borrow Madame Roland's phrase regarding liberty and exclaim, "How many crimes have been committed in thy name!" Though mistakes have been made in the past it is undoubtedly true that the net balance is on the credit side, and that the field for the use of properly heat treated material is bound to extend.

Our aim here is to discuss the proper production and the proper use of heat treated material for railway service. The most important phases of the subject are brought out in the following four questions and answers and the facts on which the answers are based are examined later in detail.

*Q. 1.*—What advantages has heat treated material over untreated material, and when should treated material be chosen?

*A.*—Heat treatment gives to steel a high elastic limit and high tensile strength combined with good ductility. As a consequence greater strength with the same weight and dimensions, or less weight with the same strength can be obtained. The treated material should be chosen when these advantages outweigh the higher cost.

*Q. 2.*—How are the above qualities obtained?

*A.*—By heating the material to the proper temperature, quenching it in oil or water to confer great strength and hardness, and reheating to a lower temperature to remove some of the hardness and restore ductility.

*Q. 3.*—What is necessary for the production of satisfactory heat treated material.

*A.*—Sound and carefully selected steel, knowledge of the proper temperatures to use, furnaces and apparatus for accurately obtaining and measuring these temperatures and a proper installation for quenching.

*Q. 4.*—What precautions are necessary in repair work on heat treated material?

*A.*—Any bending or straightening must not be done cold,

but at a temperature of between 900 deg. and 1,000 deg. F. No higher temperature must be used, or the special properties given by the treatment will disappear. Retreatment should never be attempted except where heat treatment is usually done and where apparatus and experience are available.

So far we have spoken of heat treated steel without specifying forged or cast steel. While some heat treated castings are used, heat treated forgings are more important in railway work and in what follows attention will be directed to them; the greater part of what is said about heat treatment, however, will apply to castings as well as to forgings.

The quality of any forging and its suitability for service depends on two things, first on the chemical composition of the steel, and second on the physical structure of the steel as determined by the working and heating it has undergone. The chemical composition is fixed at the time the ingot is poured, but the physical structure as disclosed by the microscope is varied by every operation of heating or working. In the ingot the structure is large grained and open, corresponding to a moderate hardness and low ductility. As the ingot is reduced to a billet by rolling, the grain becomes finer and the structure more compact, the exact condition depending on the amount of work done on the steel and the temperature at which it is done. The same process of improvement by refining the grain also takes place when the billet is made into a forging. Both the strength and the ductility of the metal are increased and it is in much better condition to resist stresses and shocks. It is difficult, however, to control the temperature at which the forgings are finished, and impossible to have the temperature at which they leave the hammer uniform throughout. As a consequence the structure of the steel will not be uniform and the unequal cooling may set up severe shrinkage strains. To eliminate these strains and to secure a uniformly satisfactory structure it is desirable, in the case of forgings for railway service which are not to be heat treated, to heat them to a temperature which will refine the grain and then allow them to cool uniformly,—in other

words to anneal them.\* The consequences of the annealing are a slight loss in tensile strength and a considerable gain in ductility.

In the heat treated forging a further step is taken. The quenching refines the grain still further and establishes a new condition in the structure, conferring on the steel superior qualities which cannot be secured otherwise. Observed from the outside the steel is seen to be heated to a certain temperature and then quenched in oil or water. This makes it hard and brittle; too hard to machine and too brittle to stand shocks. It is therefore tempered by being reheated to a lower temperature and allowed to cool slowly. This reheating removes some of the hardness and gives ductility. The extent to which the drawing of the temper is carried will depend on the service for which the forging is intended and the qualities desired. Viewed internally, by means of the microscope, it will be seen that the quench greatly refines the structure and introduces another modification which tends to disappear on the draw. The exact reasons for these changes may be left to the metallurgists. The facts of practical importance are that as steel is heated it passes through a certain critical range of temperature in which its structure changes to a form which, if preserved when cold, will produce a very hard material. Slow cooling allows this structure to disappear, but by rapid cooling, such as quenching, some of this hardening structure can be retained. The more rapid the quenching, the more nearly is the hardening structure retained and the harder will be the steel. As the steel is reheated after quenching the hardening structure gradually disappears and by stopping the reheating at the proper point any desired degree of hardness below that given by the quench can be obtained. If the reheating is carried to the critical temperature all of the hardening structure will have disappeared, to reappear after the critical temperature has been passed. The steel will now be in the same condition as before quenching and will be soft if cooled slowly (annealed) or hard if again quenched.

One of the problems of heat treatment is to determine the location of this critical temperature, and to decide on the margin above it to which the steel should be heated before quenching. A certain margin is necessary to secure satisfactory results in practice, but if this margin is exceeded the grain will be coarsened. It is impossible to give general rules for quenching temperatures because so much depends on the composition of the steel, the design and dimensions of the forging and on the conditions of the quenching. Under the conditions described below a temperature of 1475 deg. F. in the furnace before quenching will give satisfactory results with a locomotive driving axle of steel containing 0.40 per cent carbon, but a different temperature would be required if the carbon content be changed or if alloy instead of carbon steel be used.

The standard forging specifications of the American Society for Testing Materials will serve to compare the properties of heat treated with those of annealed forgings. Taking for example a locomotive driving axle about 11 in. in diameter, the minimum tensile properties required for carbon and alloy steel are as follows:

Material.	Elastic limit lb. sq. in.	Tensile strength lb. sq. in.	Elong. in 2 in. per cent	Reduction of area per cent
Carbon—annealed . . . . .	40,000	80,000	21.6	33.0
Carbon—quenched and tempered. . . . .	50,000	85,000	22.3	42.3
Alloy—quenched and tempered. . . . .	65,000	90,000	20.0	50.0

Generally speaking the allowable working fibre stress is determined by the elastic limit so that in the carbon steel the quenched and tempered material is 25 per cent stronger than

the annealed material.† By substituting heat treated alloy steel for the annealed carbon steel the strength can be increased over 50 per cent.

As has been pointed out, under conditions in which this increase in strength is worth the increased cost, the treated material is desirable. As an instance of this kind consider the valve motion and reciprocating parts of a locomotive. Weight here is a great disadvantage and at the same time the use of high grade material will not very greatly affect the total cost of the locomotive.

In producing heat treated forgings, the first problem to be encountered is the selection of sound steel. This is a difficult subject, for while it is well recognized that the steel must be of good quality it is not easy to lay down hard and fast rules for its selection. One large consumer specifies that the carbon segregation between centre and outside shall not exceed 12 per cent, but this requirement has not yet stood the test of time. For our purpose it will therefore be assumed that the manufacturer, by the best use of his judgment and his conscience, will choose good steel and forge it by proper methods.

In the process of quenching and tempering two points require consideration: the heating and the quenching. It is essential that the heating be done uniformly and accurately. The furnace should be so designed that at no point will the temperature vary more than 10 deg. to 15 deg. F. from that desired, and should be equipped with sufficient pyrometers to enable the operator to be certain that this degree of accuracy is being obtained. The quenching system must be placed so that the heated material can be transferred to it from the furnace without loss of time or temperature. It must also be arranged so as to extract from the material the required amount of heat at the desired rate. Here, in the quenching system, the success or failure of the treatment will be determined and it is here that experience is necessary.

In quenching the balance must be held between two conflicting requirements. Rapidity of cooling is desirable to retain the hardening structure, but brings with it severe shrinkage strains which, if not controlled, may destroy the material. To illustrate the character of the shrinkage strains and the damage they may cause, a locomotive driving axle will be considered. On entering the quenching medium the outer surface is chilled by contact with the fluid and therefore tends to contract, while the inner part of the axle, not having the same opportunity for cooling, does not shrink in the same proportion. As the outer surface shrinks it has to adapt itself to the enlarged central core and in so doing must be stretched. If the cooling of the surface is too rapid or if there is any considerable seam or flaw, the stretching necessary for adjustment may be beyond the capacity of the steel, and a longitudinal crack may start in the outside surface. If the cooling is somewhat less rapid the outer shell will adapt itself to the hot core; then, as the cooling effect penetrates, a shell next to the surface shell cools and stretches, and this action is continued. It will be seen that as the end of the cooling approaches the axle consists of an outer cylinder stretched but rigid, enclosing a central core which, in order to complete its cooling, has to undergo a shrinkage tending to make it occupy less space than that held for it by the cooled cylinder. This sets up a very considerable stress at the centre of the axle and if the cooling is allowed to complete itself too rapidly a radial fracture will be set up starting from the centre of the axle.

For convenience an axle has been considered, but a similar condition will be found in any forging having any considerable thickness. In a bored axle the shrinkage strains are much less than in a solid axle, for two reasons. First,

\*The editor, in announcing the competition, used the term "heat treatment" in the sense of quenching and tempering, and his example has been followed. As a general rule it is better to follow the usage of the American Society for Testing Materials in the standard specifications for forgings, which contain the following definition: "Heat treatment may consist of annealing or quenching and tempering."

†This is a conservative statement as the figures given for the annealed forgings are for yield point and not for elastic limit, while for the treated material the elastic limit is given.

the quenching fluid acts both inside and outside, producing more uniform cooling; second, the hollow cylinder is a less rigid form and avoids the difficulty of the final cooling of the central core.

So far we have considered only the shrinkage in directions perpendicular to the axis of the axle, but a very similar action takes place in a direction parallel to the axis. A chilled, rigid cylinder is formed enclosing a hotter cylinder which has still to complete its shrinkage. In the final shrinkage if too rapidly completed, the middle part of the core may pull away from the ends, a transverse fissure starting in the interior of the axle and not emerging through the outer shell until some shock is received after the treatment is completed.

To avoid internal fissures it is desirable not to let the forging cool all the way down to the temperature of the quenching medium, but to remove it from the tank and send it back to the furnace for drawing the temper while the temperature of the interior is still 400 deg. or 500 deg. F. During the reheating and subsequent cooling the shrinkage strains have time and opportunity to equalize.

The external cracking first mentioned is less likely to occur than the internal cracking and will only take place if the material is defective or if the quenching medium gives too severe a shock when the forging is first dipped.

Water, heavy oil, a mixture of oil and water and many special brands of quenching oils are advocated and used as quenching mediums. Water has the advantage of conferring excellent physical properties by reason of the rapid cooling, but for the same reason will produce dangerous shrinkage strains unless the cooling is very carefully timed. Heavy oil, such as cylinder oil, greatly reduces the danger from cracking, but quenches more slowly and therefore does not produce such good physical properties in the steel. With a view to reducing the danger of damage by water and at the same time to securing better results than can be obtained with heavy oil, various other quenching fluids are used. Some manufacturers use a mixture of oil and water similar to a drilling compound, while others use light oils of different grades. The light oils introduce a fire risk, but this need not be serious if sufficient volume of oil is provided and steps taken to prevent its temperature from being unduly raised.

The writer advocates the use of an inexpensive light mineral oil with a fire point of about 390 deg. F., a flash point of about 350 deg. F. and gravity about 29 deg. Baumé. There should be separate quenching and storage tanks, the latter to have ample capacity and to be provided with cooling coils. The oil should be pumped from the storage into the quenching tank and delivered into the latter in such a way as to produce a vigorous and positive circulation about the object to be quenched. A system of this kind has many advantages, one of the most important being that since the circulation of the oil is controlled by the pump, the rate of circulation can be varied, and the rate of cooling thus adapted to suit the needs of almost any case. Experience will show the rate of cooling desirable for each class of forging and good results can be obtained with small risk of cracking. To be on the safe side and to avoid any possible trouble with internal cracks it is considered good practice to apply a proof test to every heat treated forging. This usually takes the form of a drop test sufficient to eliminate any defective, but not sufficient to injure any sound forging.

With a quenching system as described, with care in its use and in the selection of the steel, and with a proof test on each forging after treatment, manufacturer and consumer can rely on the product being uniform and satisfactory.

It is undesirable to attempt to bend or to straighten heat treated material cold, as this will set up cold work strains. At the same time it is obvious that if the temperature be carried above that at which the material was drawn, the strength conferred by the treatment will be lost. It must always be remembered that heat treated material possesses its good

qualities because it has been heated to certain temperatures in a certain way and that if heated again to these temperatures the quality will be affected. It should be obvious from what has been said that material cannot be retreated at a repair point unless full equipment and experience are available.

## KEEPING TRACK OF SERVICE TESTS

BY E. S. BARNUM

Economy has become the watchword of railroad management. Possibly the conditions which make rigid economy necessary are forced and unhealthy, but they are none the less real. Unhealthy economy usually consists of seeing how few dollars you can spend, but healthy economy consists of spending all the dollars necessary and seeing that each one returns 100 cents of value.

Of the money spent by the mechanical department, roughly, one-third goes to labor, while the other two-thirds goes for material. Labor means output, and a survey of the situation will show that due to the pressure for output and other causes, labor, the smaller of the two divisions of the expense, receives the major share of the attention. Of course, the quantity of material bears a relation to the output, but the quality does not.

There is a large amount of material, running into sums of money which can be measured only by actual service. To follow up and secure a measure of the value of material in service sounds simple, but in fact it is one of the most

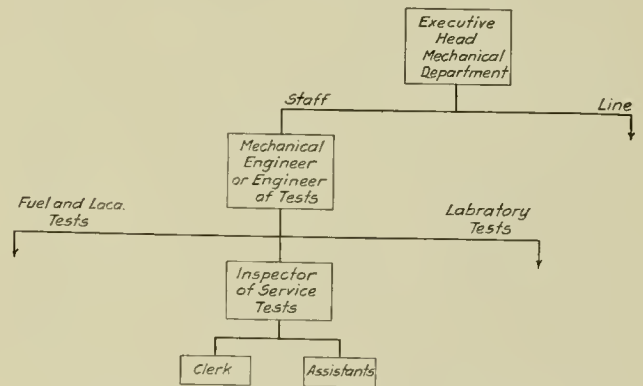

Organization for Following Service Tests

difficult and exacting tasks imaginable. Equip a few locomotives with test air pump packing, tag the pumps, and then, without giving them any more attention, allow them to run for a short time, say two months. At the end of this time take out all the packing and tabulate the results. Test packing rings and standard rings will be found in the same pumps and the sum total will be a hopeless jumble that defies analysis. At one time a test was run on some steel wheels to determine their mileage between turnings. The wheels were all calipered for diameter, and put under locomotive tenders. At the end of a few months the wheels were calipered again, and on comparing diameters what was the surprise of the investigator to find the wheels slightly larger than when they were put in new. It was then discovered that the man who made the initial measurement of diameter was not a skilled hand at using calipers. If a little more time had been allowed to elapse between observations, the evidence of error would have been obliterated, and the wheels would have been given credit for wear to which they were not entitled.

In general, the more people there are who know that a material or device is under test, the more apt you are to get accurate results, for the reason that what escapes one man will be reported by someone else. Working on this prin-

circle, there are usually a lot of circular letters sent out every time some material is put under test in service. Circular letters have a useful function, but when they are received frequently, written by the same person in the same dry style, the men who get them do not get very far before they "get wise," and this is about the result: Roundhouse foreman or car inspector, reading from a letter. "Dear Sir—In order to determine the relative value of our standard brake shoes as compared with the shoes manufactured by the X Y Z Company, it is desired to equip ——" Here the reader breaks off to remark: "Ain't it the limit. Seems like those fellows up there don't do nothin' but sit around and figger out how much trouble they can cause us. They don't ever do no worryin' about how we are going to get all this work done." Having delivered himself thus he continues to read, but in a disinterested way, his mind having received a "permanent set" against the job in question.

Why should not this letter have read, "Our yearly bill for brake shoes is (naming the correct total) —— dollars. If we can get a shoe that will give a few more hundred miles than the one we are now using, and equally as good otherwise, we can make a saving which, though small considering each shoe, will mean a considerable saving on our cost of brake shoes for the year. We are going to try the X Y Z Company's shoes, and will you kindly equip, etc." This form has a personal appeal. Pay the average employee the compliment of considering him an interested party rather than a mere cog, and see how quick he is to take hold.

One of the best examples we have of the value of the personal appeal is the results of the safety committees. The men were approached from the personal side and in many cases personally, to cut down the number of cases of personal injuries. That the return on the investment in dollars and cents has been big, is a matter of record. If the circular letter, designed to reach all persons interested, can be written so that it has personal appeal, good, but—and here comes a most vital point—no circular letter can get the interest or attention that can be gotten by a visit from the man making the test, or one of his assistants.

By paying a visit I do not mean just going into a terminal, standing around like a judge, and dismissing the matter with a bare statement that certain points should be watched and a record kept of results. Before you can get someone interested in a subject you must be interested yourself, and have determined before hand what must be asked and said, and the manner of doing it. Jake is a roundhouse repairman of average intelligence. He was stopped one day while bent over his work, and asked, "You haven't had any trouble with the X fittings, have you?" naming a special fitting. "No," he answered, looking up, "none that I know of," and his eyes meantime had traveled back, restlessly, to the work in front of him. Now, the very form of the question was negative and called for just the answer that was given. Jake's mind evidently was still on his work, and if the questioner had not begun to ply him with some roundhouse gossip of a general nature, he would have been back at it immediately. After a few moments talk the subject of the fittings was again approached in this manner. "Jake, we were looking at some of those X fittings the other day, and they seemed to be weak just back of the shoulder; looked as if they might break there pretty easy." "How do you mean?" he asked, interested, because he had been called on to use his imagination. Following up this lead brought the matter fresh to his mind, and he did remember having some trouble. Later on in the day he looked us up to give us the broken fitting, which he had taken the interest to dig up out of the scrap. The very piece of evidence we wanted.

While these personal touches give life to the job there must be a ground work of routine reports. A report blank may be used to advantage; this should be made out by the sub-foreman or a workman when he makes an examination

of any test material. It can be conveniently arranged on a 5 in. by 8 in. sheet, and should have blanks for the engine or car number, the name of the device being tested and the dates of examination, with the condition. It is not expected that one of these blanks be made out every day or even every week unless something of special interest occurs. When the test is started a stated interval for reporting should be assigned for each case. If the report is not received by the time it is due, the man handling this end of the work in the general office should send out a tracer.

What sort of an organization do we need to get results in this work? The amount of money involved is so large that it warrants all the attention and forethought which can be given to determining on the best plan. The man in charge of the testing should be close enough to the executive head of the mechanical department so that he can get all the action he needs. Any go-betweens should be open-minded. The man who is governed by prejudice, who has the habit of eliminating from consideration immediately any subject which does not appear on the face to be feasible, should not be allowed to be a factor in the organization. If there is no other way the man who is the active head should report direct to the head of the mechanical department, eliminating all go-betweens who might interfere with the work. The chart shows a suggested scheme of organization which can, of course, be changed to suit conditions. For lack of a better name, the man responsible for tests of materials, etc., has been given the title of inspector of service tests, and it will be noted that locomotive and laboratory testing are shown as entirely divorced. The inspector of service tests, not having any connection with any other work but his own, is able to devote his entire attention to a job which will assume large proportions if the bills for material are given a close inspection.

In the case of test material placed on equipment which moves from one point to another, it is necessary to check very closely to keep the various shops from removing test parts without reporting it. To get out and try to run down a case of this kind after it has gotten cold would tax the resources of a detective. Every man can supply a large variety of reasons why he knows it must have been removed at some other point. Therefore, do not forget the clerk. He plays the important part of remaining in the office, and attending to the checking up of reports and other routine matters so that the inspector of service tests and his assistants can spend their time on the firing line. Ordinarily the man who oversees service test work has most of his time occupied with other matters, and when it comes time to draw conclusions, he has to depend on correspondence entirely. He has no first hand information, and the men out on the line, knowing they are never checked up, do not burden themselves in writing up the results.

WELDING CASTINGS.—Electric or blow-pipe welding of blow-holes and shrink-holes in steel castings is now a practice recognized in specifications. If the defect is not so located as manifestly to make the casting unfit for use, and if the defect is properly repaired, a welded casting is perfectly satisfactory. The defect, however, should be really eliminated, not simply plugged—as was pointed out in a symposium on iron and steel, presented before the International Engineering Congress. By opening a hole to the bottom with the flame or arc, much as a dentist prepares a cavity in a tooth for filling, and then filling it with metal that is welded to the partly fused walls of the hole, the casting can be made truly sound. The hardening effect of the high temperature and rapid cooling upon the steel adjacent to the weld, especially in medium and hard castings, and the stresses set up by the cooling of large welds make it essential in a great many cases that the casting be reannealed after welding.—*American Machinist*.

# LOCOMOTIVE SUPERHEATER PERFORMANCE\*

## A Discussion of Present-Day Practice and the Probable Results of a Higher Degree of Superheat

BY S. S. RIEGEL

Mechanical Engineer, Delaware, Lackawanna & Western, Scranton, Pa.

Steam in a boiler in intimate contact with water exists generally at the minimum temperature of its formation, corresponding to the boiler pressure. Under these conditions it is always in the state of vapor, and said to be "saturated." Any increase in temperature will cause a rise of pressure, and any reduction in temperature will cause some of the steam to condense as water. It follows then that steam in contact with water in a boiler cannot be superheated, so a separate chamber, into which it can be passed, is necessary to raise its temperature. A chamber of this kind is called a superheater, and as this chamber invariably opens into the boiler, the steam it contains cannot exist at a higher pressure than that of the generated steam in the boiler, and can only be superheated at equal or lower pressure. This steam is dry and is called "superheated." In this condition it will resist all temperature changes within the full range of the superheat it contains, by reason of its reserve heat. This power to resist the usual condensation losses is the main reason for its use, and this should govern the rise in temperature, the amount of reserve heat, which should be given to the steam. Another most important reason for its use is its property of increased volume, as pound for pound, superheated steam has the greater volume, giving a corresponding gain in economy.

As there are now over 16,000 superheaters of the fire-tube type in service in the United States and Canada, it may be called standard equipment on American railroads and from its general use it is not necessary to go into great detail in describing it or its results, these being well known.

As a result of imperfections in material, methods of manufacture, and improper supports in the smoke-box, some of the earlier headers were not able to withstand the severe service, particularly the internal stresses, due to the rapid heat transfer, and cracks developed between the unit seats in the lower faces of the headers. This was overcome by a later design, providing free movement of the several parts—the loose-finger design, now coming into favored use. This is a through bolt header, providing additional air spaces between the walls of the saturated and superheated steam compartments, to allow for expansion and contraction and avoid a too rapid heat transfer.

Another recent improvement in the American superheater is the re-design of the superheater unit, by the substitution of a welded return bend for the old cast steel form. This new return bend is produced by welding the ends of the units together, through an ingenious combination of machine forging and acetylene welding. The torpedo-shaped ends which result offer minimum resistance to the passage of gases through the large flues and maintain liberal cross-sectional area for the free flow of steam through the units. From a mechanical standpoint the welded end is superior to the cast steel return bend unit, since it eliminates the threaded joints. The unit troubles which are avoided by the new construction are the leakages at the threaded connections between the unit tubes and the cast steel return bends, and the fractures of the tubes at these points from the weakening of the metal by the cutting of the threads.

No general change in the design or practice of operating superheater dampers has been made, although several rail-

roads have made extensive experiments in an effort to do away with dampers, but the results obtained seem to indicate that the dampers still are necessary for continued successful operation. If the damper operates properly, it is not a hindrance in any case.

The maintenance of a permanently tight connection between the unit and header depends largely on the use of proper header bolts, which cannot be stretched beyond their elastic limits when tightened. The importance of this is appreciated when we know that an average man, tightening a bolt with a 36-in. wrench, may set up a tensile stress in the bolt of over 50,000 lb. per square inch. To provide a sufficient margin of safety these bolts should be made of a material with an elastic limit of about 70,000 lb., and an ultimate strength of over 100,000 lb. per square inch. One of the superheater companies, laying particular stress on this important matter, has produced a bolt of this material.

While the economy of a superheater in coal and water is so thoroughly recognized that it now requires little elaboration, there are certain relations between these savings and the resultant increased power output of the superheater locomotive which are sufficiently fundamental to warrant discussion, however well they may be understood. That the increased power of the superheater locomotive is made possible by the water economy of the engine is self-evident, since the superheater means a decreased amount of water per drawbar horsepower developed, while the evaporative capacity of the boiler remains the same. The superheater, therefore, means more power output for every pound of water used by the engine. To utilize the maximum power developed by the superheater, larger cylinders should be used than would be possible on a saturated engine of the same size. This may readily be seen when we remember that a saturated engine gives a maximum power output at from 40 to 45 per cent cut-off. If, however, a superheater is installed in this locomotive, giving 25 to 35 per cent more steam available at the critical point, the cut-off for maximum power output must be increased from 45 to possibly 70 per cent. This increase in cut-off results in less efficiency, due to the impossibility of getting full expansion out of the steam. Increasing the size of the cylinders, by an amount equal to or proportionate to the greater steam volume available, makes it possible to get the same power at a shorter cut-off, thus utilizing the full benefit of the superheat, as well as better expansion in the cylinders.

The conversion of existing locomotives to superheaters is a problem which must be governed by local conditions, and for which no uniform or standard rule can be fixed. The cost of conversion and results to be obtained must be taken into account in each case. In general the modernizing of existing engines by the application of superheaters has permitted such power to keep pace with increased demands from the use of heavier trains, or in the meeting of more exacting service. A study of pull-speed curves will show the power developed by a saturated engine decreasing rapidly after a speed of fifteen miles per hour is reached, and the superheater, sustaining a higher power for a considerable period beyond this, as expressed in tractive effort and drawbar horsepower. This increased power output is obtained at relatively low cost per unit of tractive effort, as compared with the purchase of superheater-equipped new power. Dur-

\*From a paper read before the Central Railway Club, Buffalo, N. Y., at the May, 1916, meeting.

ing the year 1915, out of 3,667 superheaters applied in the United States and Canada, more than 2,000 were used on old engines.

It is worthy of note that superheaters are being more generally applied to both new and existing yard engines. This is comparatively a recent development, as it was formerly thought impossible to obtain a sufficient gain in yard service engines to warrant superheating. It is generally supposed that there is not much necessity to superheat switch engines, but engines so equipped handle more cars between longer periods of coaling, and taking of water, and do their work more quickly, so it would seem the superheater is properly adaptable to engines in switching service. There are now nearly 900 superheater switch engines in service in the United States, and the railroads which have operated them are ordering more, which is evidence that the results obtained must be satisfactory.

It is pleasing to state that, as we become more familiar with the use of the superheater the troubles are growing considerably less. The principal causes of the troubles are: First, differences in temperature expansions; second, lack of sustained or proper supports by liberal sized bands and supporting rests, to avoid vibrations and prevent wearing holes in the flues; third, use of improper materials for joint bolts, or bolts severely overstrained in the application of the units; fourth, construction or use of improper materials for return bends; fifth, abuse of the device by improper handling.

The following causes of loss of efficiency occur:

*Dirty Surfaces.*—The superheater should be accessible for easy cleaning, as in the roundhouse it is very important to have the flues and superheater surfaces blown clean of ashy deposits.

*Leakages of Steam.*—At all indications of leaks hydrostatic tests should be applied, as it is very necessary to keep the superheater free from leaks.

*Improper Damper Adjustments.*—Unless the dampers are so adjusted that they can open properly under automatic control, proper flow of the gases through the superheater tubes is not secured, and a great loss in efficiency is sustained.

*Maintenance of a Proper Water Level.*—A too high water level in the boiler causes the steam to carry much water over into the superheater. This may be due also to dirty water conditions, and it would appear that maximum superheat cannot be obtained except under clean water conditions, and insistence on the engineman carrying his water at the proper levels, generally as low as safe operating conditions will warrant, is necessary.

*Improper Firing.*—Firing must be very carefully done, as, when a fire is too thin, excess air will result in the cooling of the superheater tubes, and a heavy and smoky fire will smudge them and interfere with obtaining high superheat temperatures.

It is not sufficient to have lubricators which work uniformly, but drifting steam must be used under automatic control. Results without drifting steam are generally unsatisfactory. This manifests itself in carbonization of the lubricants, excessive wear of surfaces, broken packing rings, and high wear and destruction of rod packings. With drifting steam, and preferably on piston valve engines, some by-pass valve arrangement should be used, as then these conditions are generally overcome and a condition bordering on saturated steam operation can be obtained. With the solution of this problem high superheat temperature, with its greater economies, is obtainable.

It would appear that no perceptible saving is realized with less than 100 degrees of superheat, while over this the savings increase rapidly. The reason for this is that superheated steam cannot be depended upon to be dry below 570 deg. F. terminal temperatures, and as long as any suspended vapor is contained in the superheated steam, condensation will speedily follow. From this it is apparent we must come

to the use of higher degrees of superheat. To get this we may need more superheat units, and may have to adopt some more efficient way of superheating, and with it may come types requiring longer boilers, with increased diameters, and longer lengths of flues.

The superheater in its present form is very sensitive. Perhaps as we understand it in its present state of development, it may be too sensitive, but with proper handling and maintenance it is giving very satisfactory results. But it is very important from its extreme sensitiveness that the throttle valve should be opened gradually at starting and kept in such a position that there is a pressure drop at the steam chest of from five to seven pounds below the boiler pressure, as unless this is done we cannot be sure of getting dry steam delivery into the cylinders.

For the proper determination of the amount of superheat in the steam the use of some instrument like the pyrometer is necessary when the more reliable records are required, although generally speaking, it is not necessary to know when a proper degree of superheat is obtained with the normal operation of the engine. This instrument, from general experience, would seem too complicated for roundhouse care and severe locomotive service when continuously used, but for short tests it serves the purpose very well. There is, however, need for a better and more reliable instrument.

The changes in locomotive practice and design during the past few years have been so rapid and revolutionary in character that it is difficult to even surmise what the next years will develop. It is safe to say, however, that the superheater will at least remain a part of the locomotive, and in all probability have come to a higher state of development, and the point we must determine is this:

Is the type of superheater, so universally used, one which will endure, or is it apt to be superseded by a more durable and more efficient type?

#### DISCUSSION

B. B. Milner (N. Y. C.).—Quoting from a paragraph in the paper: "From this it is apparent we must come to the use of higher degrees of superheat"; I do not see that the fact that we must go to the use of higher degrees of superheat is proved by what precedes.

The broadest measure of efficiency in the operation of a locomotive is, as I see it, the coal consumption per unit of power developed; that is, the coal per horsepower hour. Whether that be drawbar or indicated horsepower is of no moment, since the difference between indicated horsepower and drawbar horsepower is not a function of superheat. This measure of ultimate efficiency in the operation of a locomotive as a power plant may be divided very logically into two sections: that pertaining to the boiler efficiency or to the boiler as an instrument for evaporating water, and that pertaining to cylinder efficiency, or to the cylinders as being instruments making use of the steam delivered to it by the boiler. In the boilers using superheaters of the type which is in general use in this country, we sacrifice, to some extent, evaporating heating surface. To some extent, perhaps not in direct proportion exactly, but to a certain extent, the provision of superheating surface reduces evaporating heating surface and, to somewhat less than that extent perhaps, I should not say proportionately, you are reducing the efficiency of your boiler as a water evaporator when you dispense with evaporating heating surface by the application of a superheater of the fire-tube type.

Cylinder performance is materially increased by the use of the superheated steam. That increase may be studied by division or separation of the losses which usually occur in saturated steam cylinder operation. First of all and most important, is that due to the initial condensation. The steam in a saturated locomotive is part water before it gets to the piston and the significance of the initial condensation losses

may perhaps be made very apparent when I quote a few percentages from data from some of Professor Goss's investigations made in a long series of tests at the Purdue University testing plant and appearing in his work on Locomotive Operation. He therein presents tables showing the percentage of steam accounted for by the indicator card, at a series of cut-offs and for a series of speeds. I shall read for 25 per cent cut-off at speeds increasing by increments of 10 miles an hour from 15 miles an hour—72 per cent, 76 per cent, 80 per cent, 79 per cent, 80 per cent. The minimum amount of steam accounted for, therefore, is 72 per cent, while the maximum is 80 per cent. I only want to bring home to you the fact that the initial condensation losses in a saturated engine are very significant, at least 20 per cent, according to these figures, and as high as 28 per cent. The use of properly superheated steam eliminates that loss.

There must be a limit to the amount of superheat we can use economically and to the distance which we can travel on the road of increasing superheated steam temperatures. With our present type of superheater it means that we will put in more superheater units. Imagine for the moment, doubling the number of units which you are using in some of your modern engines and you will appreciate that the efficiency of the boiler as a water evaporator will at some point be reduced to a point where you will not be able to get enough water from your boiler to keep going. On the one hand you have the counteracting increased cylinder efficiencies resulting from the introduction of superheat, but at some point in traveling the road of higher and higher superheat temperatures, your curve of combined cylinder and boiler efficiency will begin the downward trend as you approach the conditions of excessive superheat which I have just pictured. Now, somewhere between those two extremes is the superheat temperature, representing the condition of superheating capacity which will give us the maximum of combined efficiency; I mean the combination of the boiler efficiency and the cylinder efficiency.

Imagine for the moment, a simple locomotive of superheating capacity sufficient to give a total temperature of say 650 deg. Imagine that the engine is operating under usual running conditions and that steam is entering the cylinders at 650 deg. Then, for the moment, speculate upon what may be the temperature of the steam that is going from the exhaust. I surmise that the steam which is actually coming out of the exhaust is much above saturated steam temperatures. To the extent that the total of heat leaving the stack has been increased, the provision of superheat represents a loss.

I do not want to suggest that I do not believe in the superheating of steam. I do. But I am wondering if we had not better at this time take some inventory of what we now have and speculate very carefully upon the question of whether we have yet reached the amount of superheat which will give us maximum efficiencies; particularly in view of the maintenance difficulties, the increased maintenance expenses, which are already very real, and must materially increase if we increase the steam temperatures we use.

G. E. Ryder (Locomotive Superheater Co.).—In speaking of superheating existing engines, the author has rightly stated that the conversion problem involves a careful consideration of local conditions. The cost of conversion, equated against the results that are to be obtained, is the final deciding factor which determines whether or not the investment is to be justified. While this consideration is applicable to concrete problems, the effect that superheating will have on the operation of the locomotive, the saving in fuel, and the increased hauling capacity are established and will apply in general to any type or class of locomotive under consideration.

A study of pull-speed curves mentioned by the author invariably shows practically coincident figures for drawbar horsepower and drawbar pull for both saturated and super-

heated locomotives from starting to about ten or twelve miles per hour. From this speed on through higher speed the superiority of the superheater locomotive is apparent and the gain in drawbar horsepower with the consequent tractive power increase is realized. The maximum capacity of the saturated engine is much lower than that of the superheater locomotive and is reached at a much slower speed. It will be noted that the capacity also falls away much more rapidly in the case of the saturated locomotive.

The difference between the curves of drawbar horsepower or drawbar pull, which is, of course, tractive power, at any given speed represents the gain in locomotive capacity at that speed which is realized by superheating. As an illustration, let us refer to the accompanying pull-speed curve, which is characteristic, and taken from the result of tests of maximum capacity at increasing speeds of consolidation locomotives identical with the exception that one is equipped with the superheater and one is not. The superheater locomotive, at a speed of 30 miles per hour, is developing 350 to 400 more horsepower which is available as increased drawbar pull or tractive effort. This amounts to 5,000 lb. and repre-

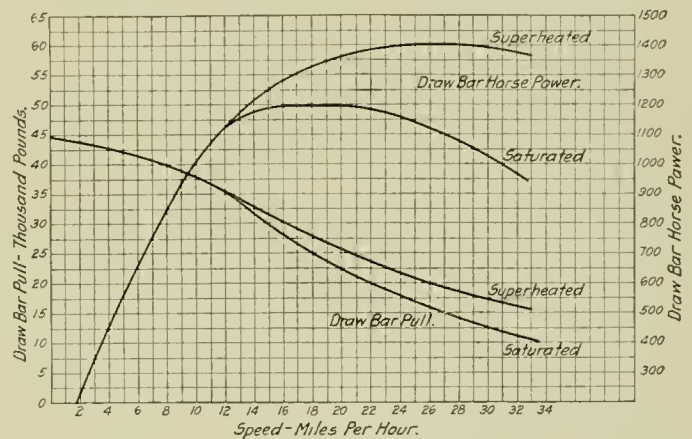

Speed-Pull Curves for Saturated and Superheated Steam Locomotives

sents a net gain in locomotive capacity obtained by the application of the superheater. Reducing this to a unit basis, in order to compare this cost with the cost of obtaining increased tractive power from other sources, it is found that in applying superheater to an existing piston valve engine at a cost of approximately \$1,700, increased tractive effort may be obtained at a cost of about 40 cents per lb. The application of a superheater to a slide valve engine, necessitating a change to piston valves, increases the first cost to about \$2,500, and represents the purchase of increased tractive effort at about 55 cents per lb. These figures are computed from results obtained at a speed of 30 miles per hour, and when used for comparison should be compared on the same basis.

H. B. Oatley (Locomotive Superheater Company).—It is evident from Mr. Milner's remarks that he has been thinking somewhat along the same lines as many of us who have been particularly interested in the development of the superheater. With some of his statements I can agree, but with some of the conclusions which he has reached I feel compelled to differ.

In the first paragraph of the paper, the question of the degree of superheat is briefly referred to. I think the writer of the paper and the speaker are in accord as to the basic principles of superheated steam and its application and that I may, without giving offense, differ slightly from him on the question of the amount of superheat and the relative importance of its advantages. It is true that superheated steam is the only medium by which cylinder condensation can be entirely eliminated, but I do not feel that the elimination of

condensation losses is a measure of the amount of superheat to be advantageously employed. I think that in superheated steam the increased volume per unit of weight, together with its increased fluidity, is an advantage which is on a par, at least, with the elimination of condensation.

Under the heading of the use of higher superheat temperatures, Mr. Riegel has touched upon a phase of the subject which has been very prominent in the minds of all who have been looking into the future. There is practically no limit to the temperature that can be given to the steam in the steam chest, whenever railroad organizations are ready to still further increase the efficiency and capacity of their locomotives. It is more than probable that the present type of the fire tube superheater will undergo modifications, as we are called upon to deliver steam at higher temperatures, although the present type "A" superheater has a considerable margin in this respect that has not yet been utilized. I presume that the railroad with which Mr. Riegel is connected is using a higher average steam temperature on its locomotives, than any other road in this country. This is due to several causes, among which are the kind of fuel, severe operating conditions, and last, but not least, appreciation on the part of the motive power department of the Lackawanna, of the advantages of the higher steam temperatures. I presume that if you were to ask Mr. Riegel to be allowed to take out a few units from his Pacific engine, you would "start something." I feel very positive about this, because I asked the question of other railroad men and found them unwilling to reduce steam temperatures. There are, of course, various ways of looking at the question of increased amount of superheat and I find one point of view that is occasionally encountered, which hinges on the fact that superheat is present in the exhaust and that an increase in the initial superheat will increase the exhaust temperatures. This has seemed to the minds of a few as spelling "loss" rather than "gain." When it is considered that the increase in volume of the steam by superheating is extremely rapid, and that this increase in volume per unit of weight

of increased temperature. The diagram shows the reduction in fuel consumed, obtained by an increase of 50 deg. in the superheat. Two series of tests were conducted on engines of identical size and weight, and with boilers of identical size, the difference being in the temperature of the steam at the steam chest. The upper line marked *A* is given a value of 100 per cent, and represents the fuel consumption of the engine with the lower superheat. The line marked *B* shows the relative fuel consumption of the engine which had the 50 deg. increase in superheat. It was found that the higher superheat engine used only about 94 per cent as much fuel as the other engine, up to an output of about 1,550 horsepower. Above this rate of working the fuel consumption dropped until at the limiting output of the lower superheat engine, the fuel consumption was only 87 per cent and, furthermore, the higher superheat engine gave an output of about 200 indicated horsepower more than the lower superheat engine. I can appreciate that the talk of fuel economies of from 6 per cent to 13 per cent does not sound very big in this present day and age, but the figures given represent economies obtainable over present superheater engines by an increase of but 50 deg. in steam temperature.

It would seem to me that in the paper there has been a misprint and that the steam temperature mentioned should have read 470 deg. instead of 570 deg. I feel quite sure that in locomotive practice, at least with steam superheated in the fire-tube type of apparatus, providing for a thorough mixing of the steam, that above a temperature of about 500 deg. F., there would be no suspended moisture present. My opinion in this matter in no way affects my endorsement of Mr. Riegel's statement that we must come to the use of higher degrees of superheat. To get this higher degree of superheat, the present form of apparatus, as referred to some few minutes ago, has possibilities that have not yet been exhausted. This limit of the present type "A" apparatus is somewhat variable and depends, to a great degree, on the size and shape of the boilers to be dealt with. We have developed and experimented somewhat with a modification of the standard fire-tube superheater, known as the type "E." Practically any degree of superheat, within reason, can be developed with this design. It can be fitted in a boiler so as to provide increased power output over the standard, or type "A." It is my firm belief that future development of the superheater will be along some such lines. The final paragraph of Mr. Riegel's paper I would personally interpret as referring to some such development as I have just described. To me it suggests a *development* of the fire-tube type rather than a suggestion of a *different* type, which would, by many, be interpreted as referring to a barrel type or a front end superheater, or some design other than the fire-tube construction.

The question of lubrication is something that we have had to study, and I believe it may be fairly said that the difficulties in going from saturated steam to 200 deg. of superheated steam have been overcome. The step made thus far has been a greater one than the step from 200 to 300 deg., or even 350 deg. of superheat.

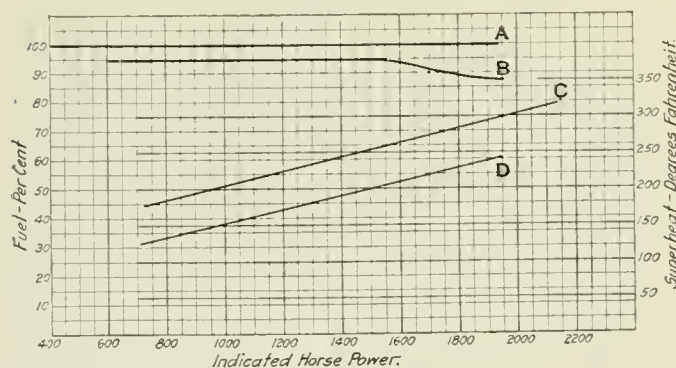

Curves Showing Fuel Reduction in Per Cent Due to An Increase in Superheat; Engine with Superheat as Shown in Curve D Used as a Base

means a reduction in the weight of steam used per revolution, and when we further consider that the increased heat content is very slight in comparison with the increase in volume, it will be evident that the amount of steam used and, therefore, the amount of coal burned will be decreased as we increase the initial superheat. The fact that the exhaust is at a slightly increased temperature will not be a source of loss. Another fact that must not be lost sight of is that with the increased initial steam temperatures, there is a decrease in the back pressure in the cylinder. This has been very pronounced in superheater engines which are now running, and it will be even further decreased as we increase steam chest temperatures still further.

Some very interesting data on this point has recently been obtained and is impressive in demonstrating the advantages

PREPARING IRON FOR MALLEABLE CASTINGS.—The iron for malleable castings is almost always melted in the air furnace or small openhearth furnace, as it has been found that the cupola cannot be depended upon to give metal of sufficient uniformity to insure successful malleableizing. The composition of the metal has to be kept within quite close limits, which vary in accordance with the size of the castings being made, and the manufacturer has to exercise much skill and ingenuity in designing his patterns and molds. The castings are packed in iron boxes, which are heated to a red heat in annealing furnaces of the ordinary type. They are annealed for several days, and test bars or castings in each box are tested in order to be sure that the process has been properly performed.—*American Machinist*.



# LARGE CONSOLIDATION LOCOMOTIVE

Designed for Use in Ore Traffic on the Lake Superior & Ishpeming; the Total Weight is 268,000 lb.

Three large Consolidation type locomotives, developing a tractive effort of 55,900 lb., have recently been built for the Lake Superior & Ishpeming by the Baldwin Locomotive Works. These locomotives will be used for ore traffic, their most exacting service being to haul trains of empty steel cars up a grade of 1.63 per cent, combined with curves of 5 deg. The question as to whether Consolidation or Mikado type locomotives should be built for this service was carefully considered and it was decided that, as the run is

measuring 33 in. in diameter and 12 in. in height. It contains a throttle valve of the improved Rushton type, with drifting valve. The vertical throttle pipe is flattened in cross-section, and placed sufficiently far forward in the dome to enable a man to enter the boiler without dismantling the throttle valve and its connections. The longitudinal boiler seams have a strength equal to 90 per cent of the solid plate. The seam on the dome ring is welded throughout its length on either side of the dome opening. The injector check is

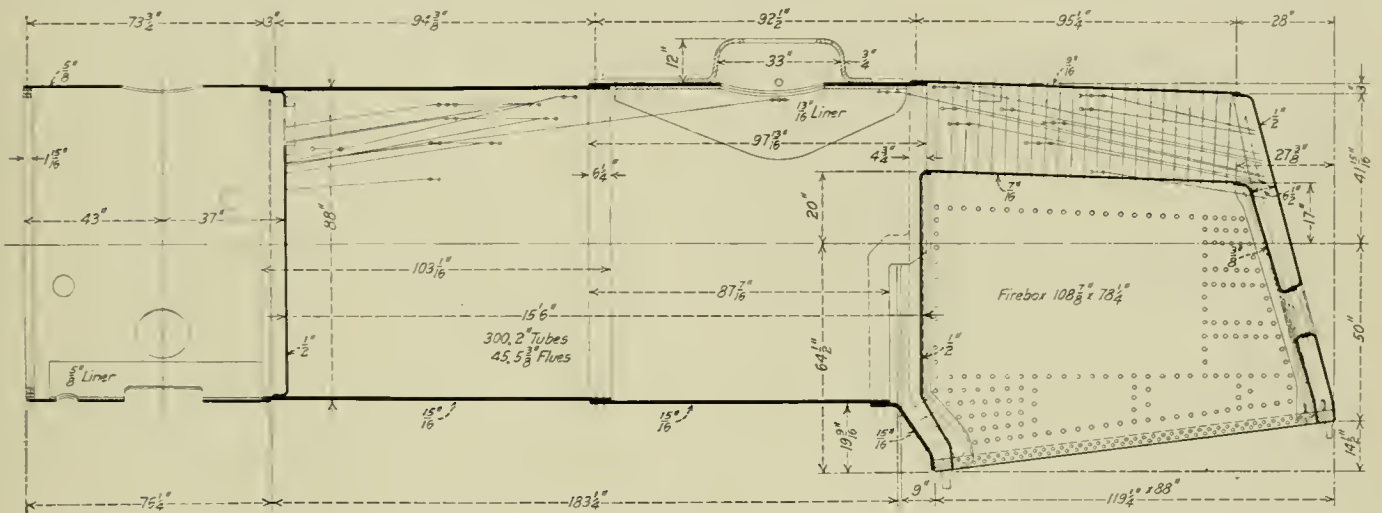

Boiler of the Lake Superior & Ishpeming Consolidation

made at comparatively slow speed, the Consolidation type would be fully capable of meeting the requirements. Furthermore, the Consolidation could be designed with a total wheel base of the engine and tender to suit the turntables, which have a length of 65 ft. A fourth locomotive, similar in all respects to those referred to above, has been built for the Munising, Marquette & Southeastern.

The boiler used in this design is of the straight top type,

placed on the top center line, and the seam on the first ring is welded on either side of the check hole, and this seam is also welded at the ends. The front end of the firebox crown sheet is supported by three rows of Baldwin expansion stays.

This boiler is of unusually high capacity for a Consolidation type engine. It contains a 45-element superheater, which provides a heating surface of 844 sq. ft., and the



Heavy Consolidation for the Lake Superior & Ishpeming

with sloping roof, throat and backhead. The center line is placed 10 ft. 4 in. above the rail, and by sloping the mud ring toward the front there is room for a throat 19 9/16 in. deep. The furnace contains a Security sectional arch, supported on four water tubes. The dome is of pressed steel,

total equivalent heating surface, assuming each square foot of superheating surface as equivalent to 1 1/2 sq. ft. of evaporative heating surface, is 4,909 sq. ft.

The cylinders and steam chests are lined with bushings of Hunt-Spiller gun iron, and the same material is used for

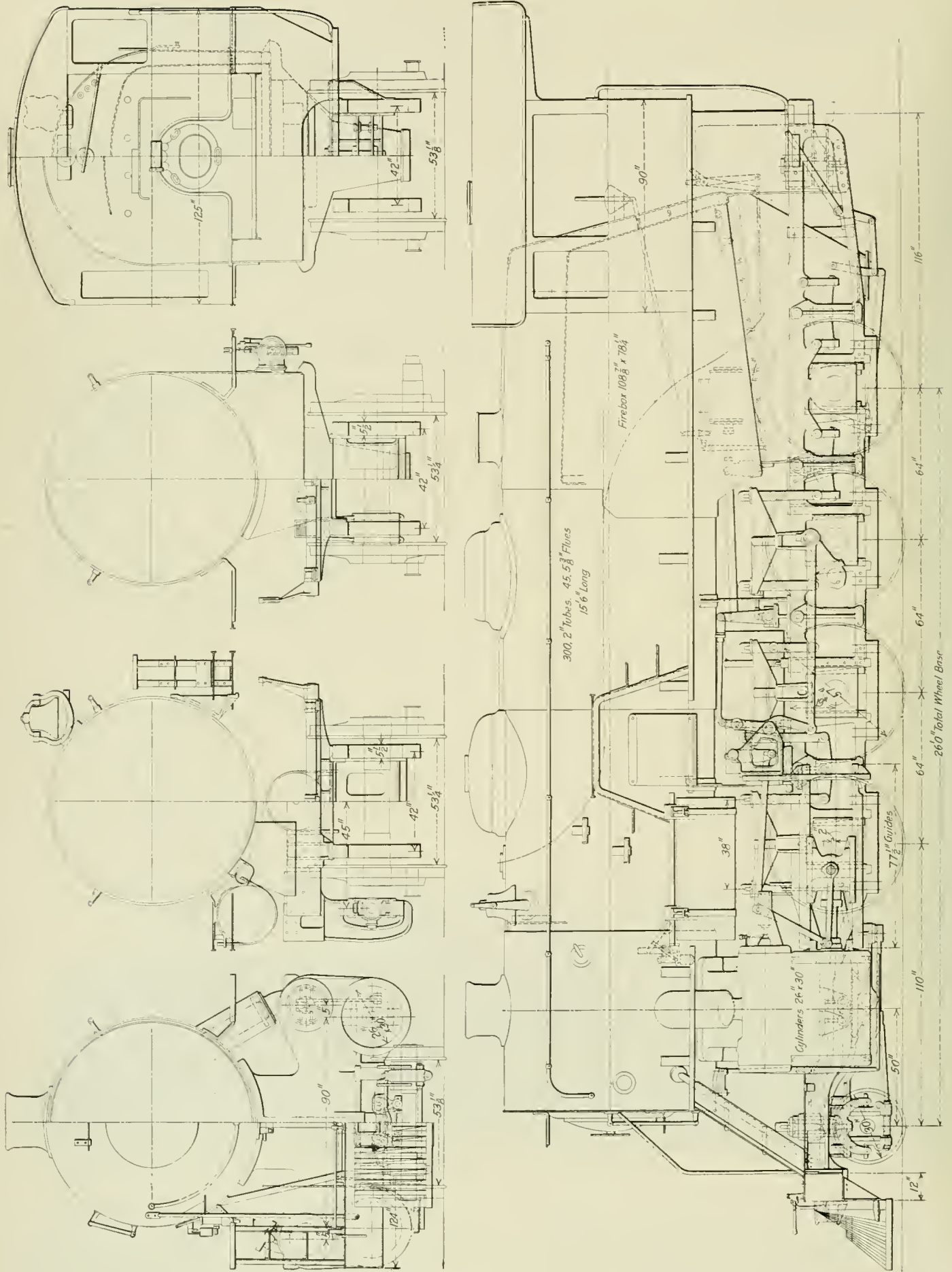

General Arrangement of the Lake Superior & Ishpeming Consolidation Type Locomotive

the piston and valve packing rings. The Nathan automatic vacuum breaker is applied. The valve motion is of the Baker type, and the gears are controlled by the Ragonnet power reverse mechanism which in this case can be operated by either compressed air or steam. The valve motion bearers are supported on the guide yoke. The cross-head link is attached directly to the cross-head wrist pin, thus saving weight and simplifying the design.

Each main frame is cast in one piece with a single front rail, and has a width throughout of 51½ in. The transverse frame braces include a large steel casting which supports the front end of the firebox, and is extended forward to brace the main driving pedestals. The brake cylinders are supported on the main frames, just forward of the leading driving pedestals. The brake shaft is fulcrumed on two steel castings which are bolted to the frames under the cylinder saddle. These castings also serve to support the engine truck radius-bar cross-tie.

The tender frame longitudinal sills consist of 13-in. steel channels. The tank is of the water bottom type, with a

<i>Cylinder</i>	
Kind .....	Simple
Diameter and stroke .....	26 in. by 30 in.
<i>Valves</i>	
Kind .....	piston
Diameter .....	14 in.
<i>Wheels</i>	
Driving, diameter over tires .....	57 in.
Driving, thickness of tires .....	3½ in.
Driving journals, main, diameter and length .....	11 in. by 13 in.
Engine truck wheels, diameter .....	30 in.
Engine truck, journals .....	6½ in. by 12 in.
<i>Boiler</i>	
Style .....	Straight
Working pressure .....	185 lb. per sq. in.
Outside diameter of first ring .....	288 in.
Firebox, length and width .....	168¾ in. by 78¼ in.
Firebox plates, thickness, sides and back, ¾ in.; crown, 7 16 in.; tube, ½ in.	
Firebox, water space .....	Front, 5 in.; sides and back, 4½ in.
Tubes, number and outside diameter .....	300—2 in.
Flues, number and outside diameter .....	45—5½ in.
Tubes and flues, length .....	15 ft. 6 in.
Heating surface, tubes and flues .....	3,398 sq. ft.
Heating surface, firebox .....	216 sq. ft.
Heating surface, arch tubes .....	29 sq. ft.
Heating surface, trial .....	3,643 sq. ft.
Superheater heating surface .....	844 sq. ft.
Equivalent heating surface* .....	4,009 sq. ft.
Grate area .....	57.7 sq. ft.
<i>Tender</i>	
Weight .....	157,000 lb.
Wheels, diameter .....	33 in.
Journals, diameter and length .....	6 in. by 11 in.
Water capacity .....	8,500 gal.
Coal capacity .....	13 tons
*Equivalent heating surface = total evaporative heating surface — 1.5 times the superheating surface.	

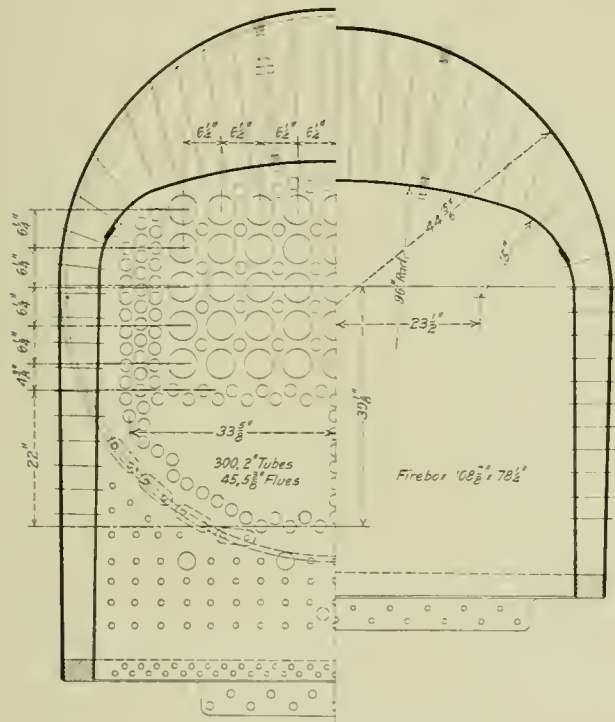

Cross Sections of the Boiler

capacity for 8,500 U. S. gal. of water and 13 tons of coal.

These locomotives rank among the largest of the Consolidation type thus far constructed, and probably represent the maximum capacity obtainable in this type with the weight and clearance limitations imposed.

The following are the principal dimensions and data:

<i>General Data</i>	
Gage .....	4 ft. 8½ in.
Service .....	Freight
Fuel .....	Bit. coal
Tractive effort .....	55,900 lb.
Weight in working order .....	268,000 lb.
Weight on drivers .....	238,000 lb.
Weight on leading truck .....	30,000 lb.
Weight of engine and tender in working order .....	425,000 lb.
Wheel base, driving .....	16 ft. 0 in.
Wheel base, total .....	26 ft. 0 in.
Wheel base, engine and tender .....	60 ft. 11½ in.
<i>Ratios</i>	
Weight on drivers ÷ tractive effort .....	4.26
Total weight ÷ tractive effort .....	4.80
Tractive effort × diam. drivers ÷ equivalent heating surface* .....	650.00
Equivalent heating surface* ÷ grate area .....	85.20
Firebox heating surface ÷ equivalent heating surface* per cent. ....	4.40
Weight on drivers ÷ equivalent heating surface* .....	48.40
Total weight ÷ equivalent heating surface* .....	54.60
Volume both cylinders .....	18.50 cu. ft.
Equivalent heating surface* ÷ vol. cylinders .....	265.00
Grate area ÷ vol. cylinders .....	3.43

### INTERESTING FACTS CONCERNING GRADE RESISTANCE AND CAR FRICTION

BY HUGH G. BOUTELL

While making a number of dynamometer car tests to establish satisfactory tonnage ratings on a certain railroad, two curious facts were brought out.

In the first place, it was determined that on at least one division of the road the ruling grade was not the same for all trains. It was somewhat of a surprise when a short train was taken out for a test run and was nearly stalled on a grade where only a moderate drawbar pull showed on the dynamometer record for the previous test of the long train. In fact, the grade was not considered as the ruling grade of the division at all.

For a time those in charge were at a loss to account for this, particularly as the grade in question was a very short one, and seemed insignificant compared with the so-called ruling grade several miles long at another point. In this very fact, however, was found the explanation. It was actually shorter than the long train and just a little longer than the short train. In the first case only about half the train was on the hill at one time, the remaining portion being on the level track at each end. Therefore the locomotive had only to lift one-half the train up the grade at one time, while with the short train all the weight had to be lifted at once. Upon investigation it was found that this little hill really was a grade of about one per cent. Of course, if this grade had been so located that the train could take it at comparatively high speed it would have had but little effect on the drawbar pull, but the conditions in this case compelled the train to approach slowly through a town.

The second point noted during the tests was that the resistance of a given car varies to a considerable extent, depending upon the character and distribution of the load in the car. It was proved quite conclusively that a 50-ton gondola car loaded to capacity with coal is easier to haul than the same car loaded with rock. As a general thing on a road with a large number of curves, the higher the center of gravity of the load, the easier the car seems to be to haul. Car equipment used in the transportation of crushed rock for ballast is notoriously hard to haul, the reason usually given being the poor condition of this equipment, but it is probable that the low center of gravity of the load is often responsible

EXAMPLES OF RECENT LOCOMOTIVES OF THE MOUNTAIN, PACIFIC, TEN-WHEEL, MOGUL AND SWITCHING TYPES

ARRANGED IN ORDER OF TOTAL WEIGHT

Table with columns for Type, Name of road, Road number or class, Builder, When built, Tractive effort, lb., Weight, total, lb., Weight on drivers, lb., Weight on leading truck, lb., Weight on trailing truck, lb., Weight of tender, loaded, lb., Wheel base, driving, ft. & in., Wheel base, total engine, ft. & in., Wheel base, engine and tender, ft. & in., Diameter of drivers, in., Cylinders, number, Cylinders, diameter, in., Cylinders, stroke, in., Valve gear, type, Steam pressure, lb., Boiler, type, Boiler, smallest outside diameter, in., Tubes, number and diameter in inches., Flues, number and diameter in inches., Length of tubes and flues, ft. & in., Heating surface, tubes and flues, sq. ft., Heating surface, firebox, sq. ft., Heating surface, total, sq. ft., Heating surface, superheater, sq. ft., Heating surface, equivalent\*, sq. ft., Grate area, sq. ft., Firebox, length, in., Firebox, width, in., Kind of fuel, Tender, water capacity, tons or gallons, Tender, fuel capacity, gal., Weight on drivers ÷ tractive effort, Total weight ÷ tractive effort, Tractive effort X diam. drivers ÷ equivalent heating surface ÷ grate area, Firebox heating surface ÷ equivalent heating surface\*, per cent., Weight on drivers ÷ equiv. heat. surface\*, Total weight ÷ equiv. heat. surface\*, Volume both cylinders, Equiv. heat. surface\* ÷ vol. cylinders, Grate area ÷ vol. cylinders, Reference to photographs, drawings or description

\* Equivalent heating surface = total evaporative heating surface + 1.5 times the superheating surface. † Includes arch tube heating surface. ‡ Railway Age Gazette, Mechanical Edition.

# Car Department

## SUGGESTIONS FOR IMPROVEMENT IN CAR DESIGN

The following are the three prize-winning letters which were submitted in the contest on "How Can the Car Designer Improve?" This contest closed June 1, and the prizes were awarded on the basis of the practical suggestions offered.

BY C. H. FARIS

Scientific car designing is still in a crude state of development. Many attempts at scientific designing have been made and much "fingering" of cars has been done, but results have not been entirely satisfactory and no uniform practice or method has yet been developed that can be recognized as standard. Very little literature exists on the subject, and such as there is exists in the files of the different railway technical journals. Examination of these articles shows considerable variation in the methods and principles employed, and acquaintance with railway and car building drafting rooms also shows great differences in practice. Under such circumstances it is not surprising that "some classes of equipment spend too much time on the repair track," while "others may be too heavy in comparison with the revenue load which they will carry to be satisfactory to the operating department."

Improvement of the work of the car designer may be effected in two ways: first, in the improvement of the qualifications of the designer himself, and second, in the extension by comprehensive research of the knowledge of the principles and assumptions upon which such designing must be based.

The qualifications desired for a car designer are a sound and practical working knowledge of the subjects of mathematics, mechanics and strength of materials, good, common-sense judgment and enough shop and road experience to form a basis for the proper co-ordination of practical and theoretical knowledge. Persons having this desirable combination of qualifications are not abundant, but in most organizations there are men having the capacity for developing into first-class designers if means can be devised for their discovery, encouragement and training. The perfection by our industrial organizations of means for the scientific examination and classification of employees, according to fitness and capacity, will bring wonderful results.

Apart from the personal qualifications of the designer, there is need that the knowledge of principles, assumptions and methods of car designing should be extended and this knowledge formulated and made available for the car designer's use. Some good work of this kind has already been done. In 1896 a committee of the Master Car Builders' Association made a thorough investigation, both theoretical and experimental, of the design of axles, with the result that a method and formulas for this work were recommended to the association that have proved entirely satisfactory for the design of all car axles since that time. More recently, during the past two or three years, committees on car construction of this association have investigated the effects of buffing action on center sills of freight cars and have worked out methods of analysis that promise a complete solution of the

problem of designing center sills for buffing stresses. The United States Post Office Department specifications for the construction of steel postal cars furnishes an outline of a method of procedure for the design of steel postal cars, the principles of which are largely applicable to the general design of steel passenger cars. These specifications represent the best and most authoritative statement of such principles available and are widely followed as a basis for passenger car design.

Further principles that need to be established as a guide for designing practice are: Satisfactory working stresses for sills and framing for freight cars; allowances to be made for oscillation and impact in calculating the stresses in these members; methods of combining the vertical loading stresses with the buffing stresses for center sills and the permissible values for these combined stresses. The post office specifications referred to above need amplification in some respects, especially in regard to the assumptions upon which the stresses in framing and load-carrying members are to be computed.

The research work necessary to extend our knowledge of the fundamental principles of car designing can be undertaken, the writer believes, by no one to better advantage than by the Master Car Builders' Association. No person or individual corporation can have such opportunities for collecting reports from all kinds of designs and for getting the records of the results of these designs in service as are afforded to committees of this association. The establishment of the further principles and methods needed to complete our data for car designing can be done in no more satisfactory way than that in which the principles and methods we use for axle and center sill designing have been established.

BY CHAS. E. WOOD

Foreman Freight Car Repairs, Union Pacific, Kansas City, Kan.

The steel freight car has passed through the experimental stage and is now a well-established feature of railroad equipment. But it is still in process of change and improvement. Lessons are being learned from the earlier cars which are proving a great help in the design of new equipment.

But the knowledge which has been gained through observation and careful noting of the defects which appear in the different designs of cars has not been obtained in the drawing office. The designer must depend on the information furnished him from the men in the field, and the repair forces should be encouraged at all times to report all failures which may occur, and to point out the weak features of any new design. This can best be accomplished by the systematic use of defective machinery sheets supplemented by a special report of any unusual condition which may be observed.

Even this is not sufficient to cover the ground thoroughly. There are any number of practical men who do not care to put their ideas in writing, thinking it might be construed that they are criticising their superior officers who are responsible for the design of equipment, but these men could be drawn out by a sympathetic and friendly talk with the car designer, and a closer and more personal relationship would work to a very great advantage. For instance, we

would suggest that whenever any cars of a new design are about to be built that a sample car first be built and then submitted to the inspection of a committee of car foremen with a view of locating possible weak points, or errors in the design. A few slight changes in the design before the cars are built might result in the saving of thousands of dollars. The car foreman knows from experience where to look for the weak points. He may not be able to figure out theoretically the reason for the weakness, but he will be able to refer you to equipment of similar design which has caused trouble.

It has been found that draft members composed of pressed steel shapes are inclined to buckle and break; also that they are very susceptible to corrosion. The pressed steel has been replaced by the solid cast steel on nearly all new cars. Even this material is liable to bend or fracture and too much reliance should not be placed on the steel castings without giving them the necessary diagonal braces to take care of the severe side thrust which they have to meet, for instance, when being coupled on curves.

One very important feature which appears to be overlooked by a great many designers is the facility for repairing damaged parts. The theory seems to exist that a car will run through its career and never need repairs. Unfortunately this is not the case, for it matters not how carefully designed, or how carefully constructed a car may be, it will, sooner or later, find itself on a repair track. The superstructure should be built on the steel underframe in such a manner that it can readily be removed and replaced to repair a damaged and twisted underframe without the necessity of destroying the siding or flooring of the car. This can now be done in some cases, but in others it is an impossibility and results in a very material increase in the cost of repairs. But the point which is most strikingly evident is the absolute lack of proper forethought in the design and application of safety appliances. In a great many cases it is impossible to apply a hand hold on a steel underframe without mutilating the car by chopping out the sub-sills because the hand hold was riveted to the steel sill before the wood parts were applied. This is avoidable and could be remedied by bolting the hand hold in place and allowing the bolts to pass through the wood sill. In fact, the advisability of riveting on any hand holds or sill steps is worthy of serious consideration. The rivets undoubtedly make a more secure fastening, but safety appliance defects, above all others, are the ones which we all strive to repair immediately on detection and on the old wooden cars or any place where the appliance is secured with bolts it is a comparatively simple operation. We cannot, however, expect our light repair men to carry a sledge hammer and cutting chisel to cut off rivets in the train yards, consequently we have to delay the car and contents while it is switched out and taken to a repair track to remedy these minor, but nevertheless important defects.

The use of special shaped ladder irons and hand holds should also be discouraged and the standard shapes adhered to so that an appliance can be renewed from regular stock without the necessity of having it made specially by the blacksmith. By the exercise of a little ingenuity on the part of the designer this could be done in most cases where now some odd design is used.

BY DENNISTOUN WOOD

There is but little question that the drafting room force on most of our roads is not in close enough touch with the repair men and those using the cars. In some cases the drafting room is located away from the shops and unless special effort is made the draftsmen seldom see the cars built from their designs, still less come in contact with those who use or repair them. When, as in most cases, the drafting room is adjacent to the general shops conditions are not as bad, although even then they are not as they should be.

Due to pressure of work the men are usually confined rather closely to the drafting table and seldom get out in the shop. Further, repair men, having about all they can do to attend to their regular duties, are not likely to go to the drafting room to point out weak points in design.

As a remedy the following suggestions are offered:

*First.*—The chief draftsman should make periodical visits to the various shops on the line, say to one shop each month. He will thus keep in touch with the repair work being done at the various points and will be able to select the best method of overcoming each class of trouble.

*Second.*—As opportunity arises in connection with problems of design, the draftsmen should be sent out to investigate, in preference to taking matters up by letter, thus keeping the entire drafting force in close touch with the maintenance situation.

*Third.*—When a new design is to be made, the drafting room should confer with the transportation department to learn its views as to the most suitable car for the service intended.

*Fourth.*—With the information gathered as outlined above, the new design can be worked out in a general way, but before finally being settled on prints should be sent to the different shop superintendents and general car foremen for criticism, as well as to the transportation department. When received, the criticisms can be weighed and the design altered to cover such of the points as appear to be well taken.

While this system will require more time for the final adoption of a design than were the draftsman to consult no one, it should result in a great saving in money, as the changes will be made on the drawing rather than on the cars after they are built, and in many cases will also mean the avoidance of damage claims chargeable to cars of improper design.

### CARPET STRETCHER

BY C. C. LEECH

The accompanying engraving shows a simple design of carpet stretcher. The material of the toothed part and socket is soft steel and is forged out over the anvil, and a tapered steel pin may be used for forming the inside part of the socket for the handle. The toothed end is forged thin as shown and the teeth are easily laid out and filed in. No tempering is necessary and the whole forging may be rough

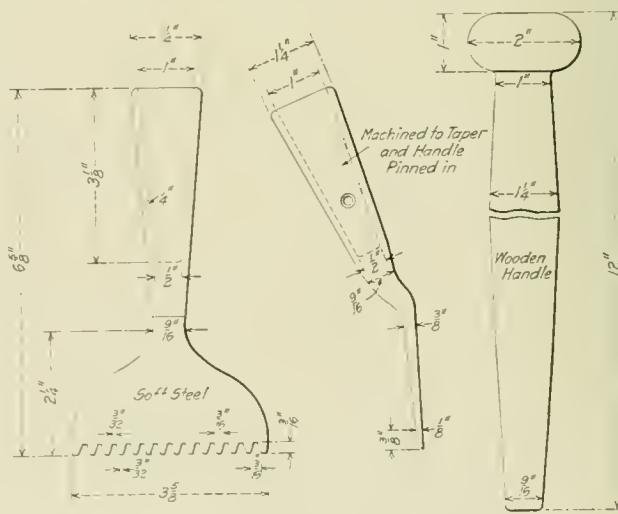

Carpet Stretcher for Use at Car Terminals

finished with a file, if desired, and painted with a coat of black enamel. The handle may be fashioned on any wood-turning lathe and should be of hard wood and shellaced. The dimensions given have been found to be about right.

# BOSTON & MAINE STEEL COACHES

First Steel Passenger Equipment to be Built for This Road Weighs 118,500 lb. and Seats 88 Passengers

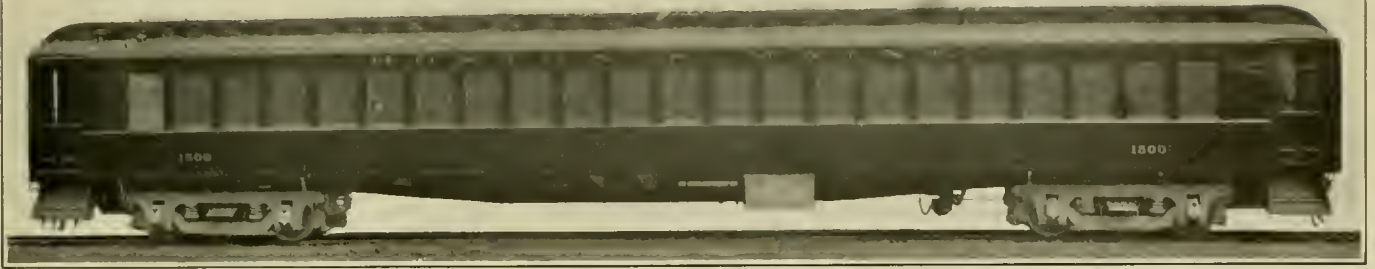

Steel Day Coach for the Boston & Maine

The Boston & Maine recently received from the Pullman Company six steel coaches and two steel smoking cars which are the first passenger cars of this type of construction which this road has placed in service. The cars will be used in the through service between New York and Portland, Me., and

5/16-in. web plates with 5-in. by 3½-in. by ⅜-in. angles outside at the top and 3-in. by 3-in. by ⅜-in. angles inside and outside at the bottom. The sills are 26 in. deep at the deepest part and are spaced 16 in. apart and there is a 30-in. by ⅜-in. top cover plate extending between the bolsters. The side sills are made up of 5-in., 11.6-lb. Z-bars riveted to 4-in. by 3-in. by 5/16-in. angles and extending the full distance between the bolsters. The floor beams are 3/10-in. pressed diaphragms, 5 in. deep, and there are two crossbearers placed 10 ft. on either side of the center of the car and built up of 5/16-in. pressed diaphragms with 6-in. by ⅜-in. top cover plates extending across the car at the top and under the center sills at the bottom.

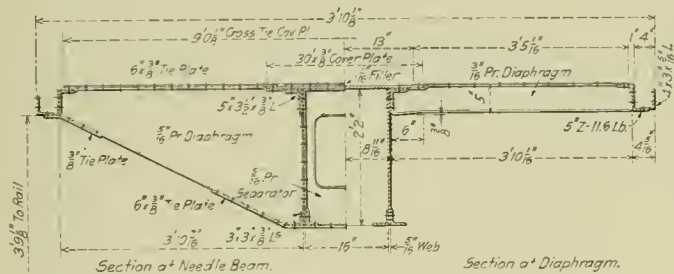

Cross Sections of the Underframe

will be followed by six 60-ft. baggage cars and two 70-ft. combination baggage and mail cars.

The new passenger cars are 70 ft. 3½ in. long over end sills, 80 ft. 3¼ in. long over buffer face plates and are

There is an anti-telescoping device which consists of two 6-in., 23.9-lb. I-beams at each end forming a part of the vestibule door post construction. In addition there are used in the body end construction a 3½-in. by 3-in. by 5/16-in. angle at the corner riveted to a 4-in., 8.25-lb. Z-bar, while there are two Z-bars of the same weight forming end posts between the door and corner posts. The door posts are 6-in., 23.9-lb. I-beams and the end plate is a 7-in., 12.25-lb. channel. The side frame construction includes a dropper bar as

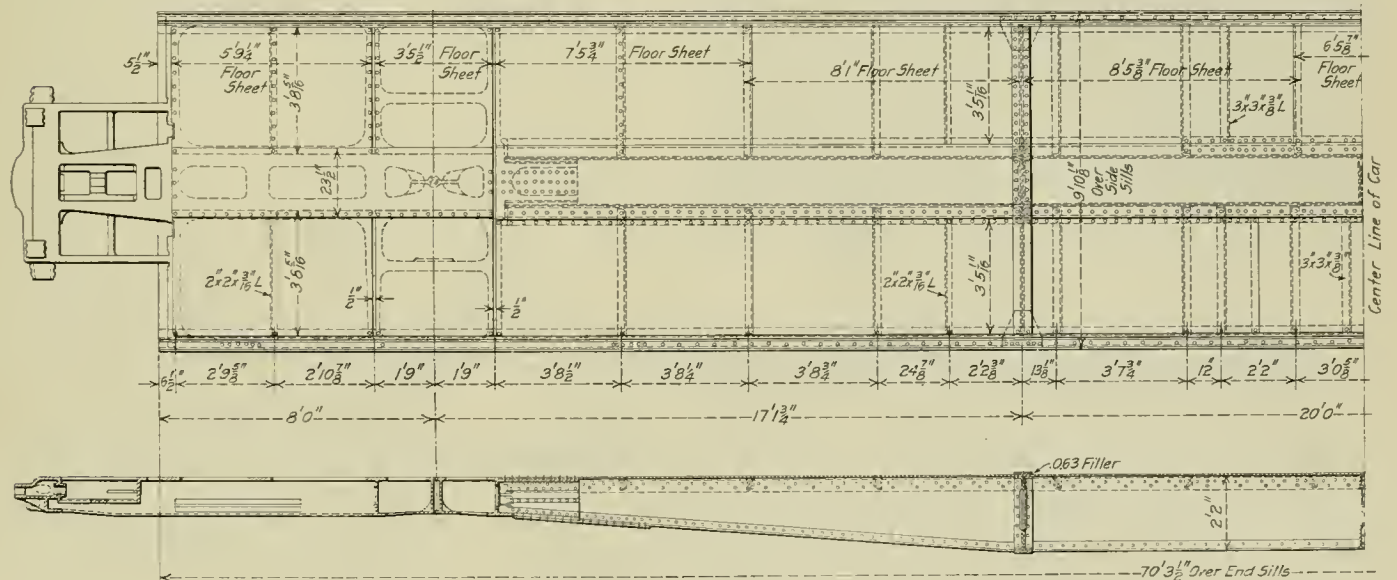

Underframe of the Boston & Maine Coach

mounted on 4-wheel trucks with 8-ft. wheelbase and spaced 54 ft. 3½ in. between center plates. Commonwealth cast steel platforms and double body bolsters are used with center sills of the fishbelly type. The center sills are built up of

belt rail, with 4-in. by ⅛-in. pressed channel side posts, two per pier.

The coaches weigh complete 118,500 lb. which gives a dead weight per passenger of 1,346 lb. The smoking cars

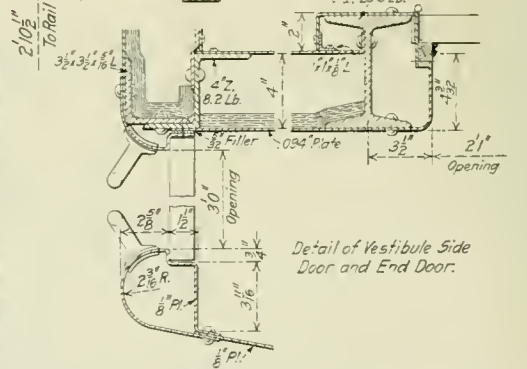
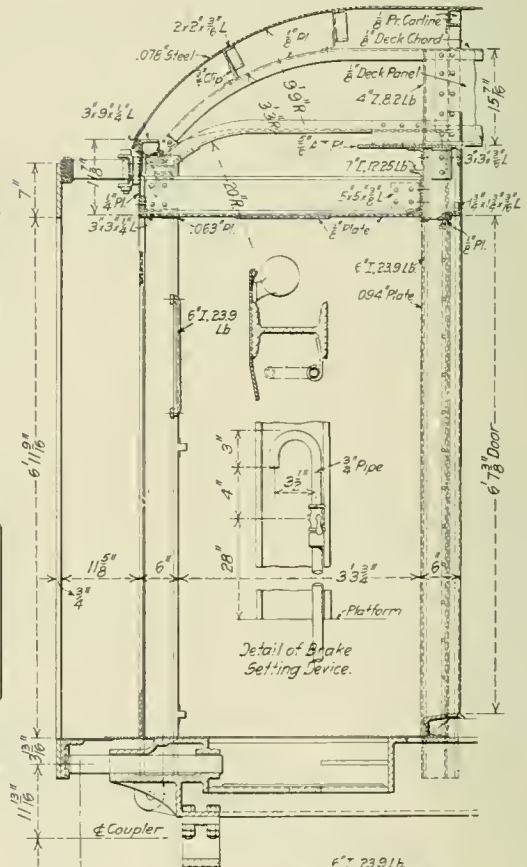
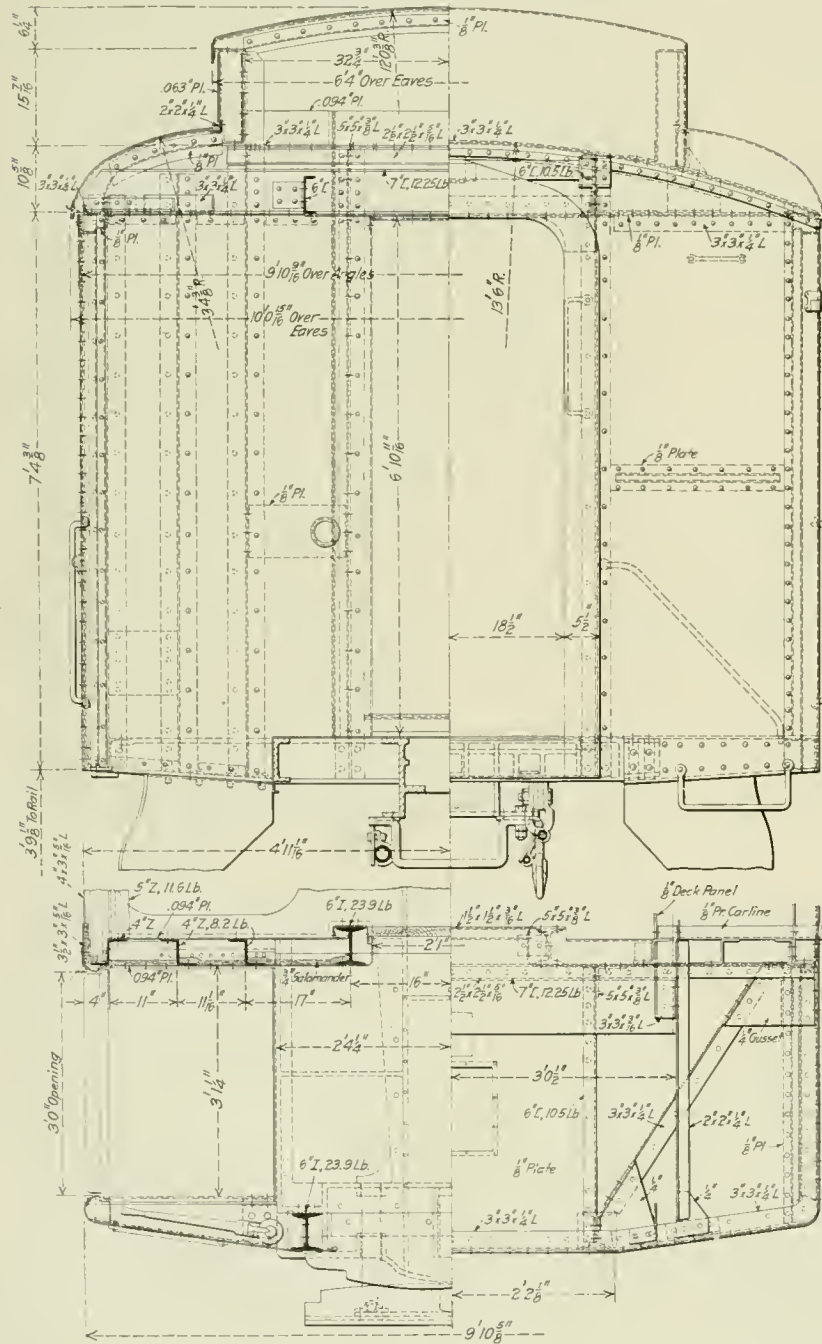
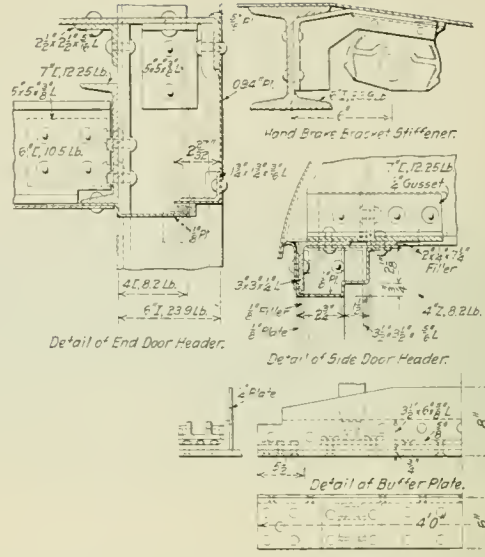
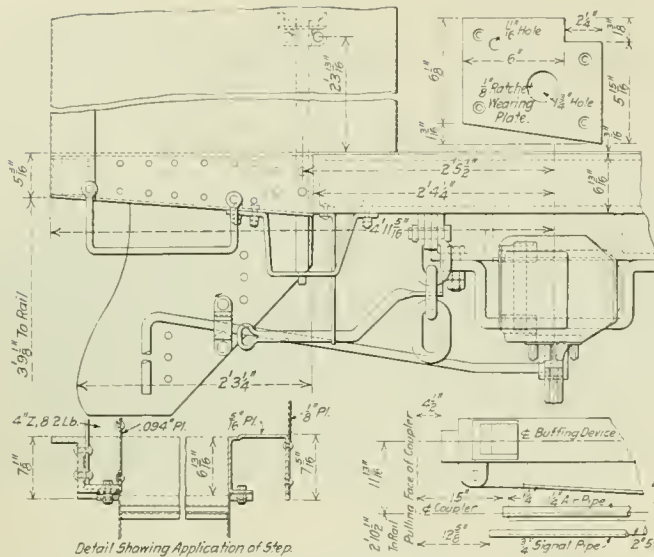

Details of the End Construction of the Boston & Maine Coach





service cylinders and 14-in. emergency cylinders. The draft gear is Miner friction type A-3-P with Pitt couplers, and the buffers are Miner friction type B-10.

## AIR BRAKE MAINTENANCE

BY JOHN P. KELLY

The following communication from F. W. Brazier, superintendent of rolling stock, New York Central, appeared on page 984 of the *Railway Age Gazette* for May 5, 1916:

To the Editor of the *Railway Age Gazette*:

I have read with a great deal of interest J. T. Slattery's letter on the Air Brake Association in your issue of April 14.

First, I want to concur in all that Mr. Slattery has said regarding the better maintenance of air brakes on freight equipment. This is a question that has been up many times, and at the last M. C. B. convention a paper was read calling the attention of all the railroads to the proper maintenance of air brakes and the parts pertaining thereto.

It is useless for one railroad to attempt to do all the adjusting and testing of air brakes. Many of the roads have gone to the expense of fitting up terminals with air testing racks and have the terminals equipped with air so they can have proper pressure to test cars and trains while they are in the yards.

I appreciate the good work which the Air Brake Association has done in calling attention to the importance of properly maintaining brakes, but, unless mechanical and operating officers provide the means and give the time for proper inspection and repairing of air brakes, we will never get any results.

Under the Federal laws we are compelled to have at least 85 per cent of the cars in a train in good condition and the sooner that officers wake up to the fact that this is a question that needs something more than talking about to get results the better it will be for all concerned. Simply accepting cars and getting rid of them without making other repairs than just enough to clear the law will not keep up the air brakes on equipment.

The M. C. B. rules are explicit as to this, and prices for doing the work on air brakes are such that the companies that do it will not be the losers. It is right up to each and every railroad, large and small to do its part, particularly in adjusting the brakes and cleaning and testing the triples properly.

Railroads are made up largely of departments. Operating officers have their special duties, mechanical department officers have theirs, and when we consider the importance of the air brakes and their maintenance and of the good work that has been done by the Air Brake Association we certainly should give that association our hearty support and take some notice of its recommendations regarding this important question.

The men that compose the Air Brake Association are, as a class, of high order, and I thoroughly agree with Mr. Slattery that they need the backing of all railroads in the good work they are doing. It is also up to all railroads to pay more attention to the care of air brakes.

This is a live question; our company has a large force of men attending to the maintenance of air brakes.

F. W. BRAZIER.

This is a subject that deserves widespread attention. Ever since the Air Brake Association has been in existence it has talked about, and insisted upon, the importance of proper and efficient maintenance of the brakes on both passenger and freight cars; but, as Mr. Brazier well says, "It is a question that needs something more than talking about to get results." This matter has been before the Master Car Builders' Association for many years, and the condition of freight brakes is still so far from being what it should be, that it is, I think, safe to conclude that the membership of the M. C. B. Asso-

ciation must be, by this time, well aware of the fact that something besides talk will be necessary to improve it. What it needed is less talk and more action. We can never talk, or "jolly," the brakes into a better condition, but by putting into practice the recommendation of the Air Brake Association the situation with respect to brake maintenance will be vastly improved.

It may be impossible for one railroad to do all the testing and adjusting of brakes necessary for the whole country, but I do not believe that "it is useless for one railroad to attempt to do all the adjusting and testing of air brakes." Any railroad can do all the work necessary on the brakes to put them in satisfactory operative condition that its present facilities will permit; and it is fair to expect that these facilities should be adequate to the demands of the road's own legitimate requirements. Since the prices paid to the railroads for doing the necessary work on the brakes of foreign cars are fair and liberal there appears to be but little excuse for not doing as much as possible, even to the extent of increasing present facilities, if need be, to take care of neglected foreign brakes. In fact, it seems as though it would be a good way in which to induce all other railroads to get the habit of maintaining their own brakes in good condition if a few energetic, up-to-date railroads would do the work necessary on these brakes to put them in proper shape, and then render the bills.

The cleaning and testing of triple valves is a very important matter, more so nowadays than ever before, owing to the large number of heavy cars hauled in a single train. A single erratic triple in a modern long train can find abundant opportunity to do serious damage. Hence it is of the utmost importance that the men employed to clean, repair and test triple valves should be conscientious, should possess more than the average intelligence, and should be men on whom the railroads can rely for the best quality of honest workmanship, worthy of their implicit confidence.

The "safety first" consideration requires that no imperfectly operating triple be permitted to get into service, and therefore no railroad should permit such valves to go into its trains, no matter how many of them may be offered from connecting lines. Any railroad is amply justified in removing such triples, and applying others known to be in good reliable condition.

There is a recommendation that the Air Brake Association has made, which is included in its recommended practice, that reads as follows: "All air hose should be tested for leakage by the use of soapsuds." Any railroad so disposed can follow this recommendation without waiting for its neighbor to adopt the practice. The air hose should be tested with soapsuds while under standard pressure for the purpose of detecting such as are leaky and porous. Such hose are responsible for a large percentage of brake pipe leakage which is so objectionable in long freight trains, and they are the kind of hose likely to rupture and cause serious damage in such trains, if the rupture occurs while the train is in motion. The loss of air through leakage in a 100 car train will amount to about 66 cubic feet of free air per minute and this leakage in itself amounts to considerable in dollars and cents, in the course of a ten-hour run.

Brake pipe leakage has other objectionable features besides the mere loss of air; it often prevents, in a large measure, the maintenance of uniform pressure throughout the whole brake pipe, causing it to be much lower at the rear end than at the front, thus making the braking power at the rear less than at the front, which is a condition conducive to train buckling in case an emergency application should be initiated at or near the front of the train.

Of course, this recommendation (to use soapsuds on the hose) cannot well be followed in freezing weather; but if practiced when the weather permits, it will enable the inspectors to detect the hose that should be removed before the train departs. After the practice has been followed for some

time it will be found that the porous hose will disappear, and the condition of the brake pipe with respect to leakage will be materially improved.

On cars that have the proper size of brake cylinder there is little need for frequent adjustment of the slack; and therefore no cars now building or being rebuilt should be equipped with a brake cylinder requiring a total leverage of over nine to produce the required braking ratio.

The Air Brake Association will, no doubt, appreciate the nice things which Mr. Brazier says of it concerning the good work it has done; but since it has done so much for the advancement of the air brake, it is only fair to expect that every railroad should give this association substantial support, and see to it that at least one or more of its air brake men, from each department, is in attendance at the annual convention, to take part in the work.

It is very likely that the suggestion made by D. F. Crawford, of the Pennsylvania Lines, at the 1915 M. C. B. convention, that the relations between the Air Brake Association and the M. C. B. Association be made closer, will be productive of much good in the way of better air brake maintenance. Example and demonstration, it is said, is far more convincing than precept, and since there is so much that any individual road can do to improve the brakes without hindrance because of whatever condition may exist upon other roads, it would appear that the only thing necessary to immediately bring about a more satisfactory condition would be simply to put into effect some of those practices which the Air Brake Association, as a body, has been so long recommending, and which wherever tried have proved so efficient.

## THE WORK OF THE CAR INSPECTOR

BY W. F. MANDRELL

An expert car inspector's value to a railroad cannot be measured in dollars and cents; there is no estimating the amount of damage and probable loss of life which may result from defective equipment being allowed to pass; or overlooked by incompetent or careless inspectors. The modern car inspector must be a bureau of information. He must know the name and value of any part of a car; he must know how repairs should be made, and also how to bill out repairs made to foreign cars. The Master Car Builders' book of rules and hundreds of special bulletins must be as familiar to him as his A.B.C.'s. He must keep posted on the Master Car Builders' Arbitration Committee's decisions pertaining to the interchanging and running of cars. There are also special rule books issued for the air brake and signal whistle system; car heating and lighting calls for another special set of instructions. Refrigerator cars have a special rule book and even tank cars are coming in for quite a few new regulations. The United States Safety Appliance Act calls for special instructions. All these rules and regulations an inspector must keep in mind as he goes about his work. I have heard some people express the opinion that a car inspector's job was "easy money." They think that all he has to do is to sit down and wait for a train to arrive and depart. At small points this may in a measure be true, but when it comes to terminals and towns and cities where traffic commences to be congested there is a different tale to tell.

For example, I will cite some of my own experiences while holding a position as freight car inspector at the terminal of the road. My duties were to inspect all trains on arrival, taking the initial and number of all cars, whether defective or not, paying special attention to grain cars for leaks in flooring, siding and roofs, and watching loaded tank cars for leaks. At times we had special bulletins requiring us to look out for our equipment that needed re-weighing, and various other things. I had to keep a complete record of defects, whether old or new, and see whether or not defect cards were on cars to cover the damages. For heavy repairs I had

to send cars to the shop; for light repairs they were marked for the repair track.

I had to keep posted as to the time trains were due to arrive in order to outline my work for the day. Once a day I had to cover the entire yard on the lookout for defective safety appliances, etc., as in the continual switching and moving of cars there is always something breaking or getting out of order and Uncle Sam's inspector does not send out advance notice as to when he will come for an inspection. I also had to inspect all cars daily in the downtown district where cars were continually being loaded and unloaded. I would inspect each car thoroughly and then mark on the side of the car whether O. K. for grain or other commodities, according to the condition of the car. In cases where cars had had roofs and were in a general dilapidated condition I would mark them "Route Home Empty for Repairs." In this manner the yardmaster did not have to bother about having the inspector find him a car to load. The switching foreman had his instructions to look on the side of the cars until he found the one he wanted. As there were always plenty of cars unloading this scheme worked out satisfactorily.

I also had to keep close watch on cars placed at the docks to load, especially the refrigerator cars placed for loading bananas, as even in switching them from the shop or "rip" track to the docks cars often became defective. The refrigerator cars are given special attention to keep from having any delay when a train is made up to leave.

On one occasion I found a car with a piece of the flange broken off the wheel; on another occasion I found that the brasses had been stolen from three cars; they were to be loaded that night and had they not been discovered there might have been a serious accident or delay, as these cars had already been oiled and inspected. I also had two interchange tracks to watch. However, this is sufficient to illustrate my point.

When it comes down to interchange work the inspector has to keep many important things in mind. The now popular "Safety First" is the car inspector's slogan, yet it depends upon his good judgment to keep traffic moving and not unnecessarily delay shipments that are oftentimes perishable. He must not only see that car and load are safe to go and safety appliances O. K., but he must look for defects or parts missing, etc., that the company would be held responsible for when the car is delivered to another road. Where there is no defect card already on the car, he must reject it until properly carded.

Railroads are saved thousands of dollars annually by having well posted inspectors on interchange work. The interchange inspector should be "Hail fellow, well met," for I believe a genial personality helps to clear up matters in all walks of life.

The inspector must keep a sharp watch on all open loads, especially piling or steel beams, etc., that are loaded on groups of two or even three cars. He must see that they are properly staked and chained together and that the loads are not too high nor too wide. He must also see that switch chains are accounted for.

In spite of all the extra knowledge a car inspector must have over the ordinary car repairer, in addition to working longer hours and seven days in the week, there still remains very little difference in the wages paid them. This, I believe, is one reason why young men with ambition usually pass by the car department for other branches of the service that offer more inducement in both better wages and quicker advancement. The responsibilities of the car inspector are increasing every year, with a certainty of becoming even more complicated, as modern efficiency and economy are constantly bringing changes for the betterment of the car department, but necessitating more care and watchfulness on the part of the car inspector. I look for the time to come when railroad officers will select men for this important posi-

tion with as much care as they would for the position of engineer.

There would be mutual benefit derived were the railroads to delegate as many of their inspectors as could be spared to the annual meetings held by the Master Car Builders' Association.

### STEEL ORE CAR

The illustration shows one of a number of steel ore cars recently built by the Ralston Steel Car Co. for the Duluth, Missabe & Northern.

The side sills of this car are composed of channels having their flanges turned inwardly to provide a flush surface for the application of channel side stakes. The end sills are connected to end sill side sills, which have the corner posts connected to them. The upper ends of the corner posts are connected to top end angles, to which the upper ends of the front and rear inclined hopper sheets are secured. The draft sills extend forward beyond the end sills and to the rearward to the inclined sheets, to which they are secured.

The bolsters are composed of diaphragms connected to the

the lower portion of the car body. The links at one end of the hopper bottom are connected with those at the other end by shafts disposed under the doors, and on these shafts rollers are mounted running into a trackway on the doors. Near the end of the hopper body, short shafts are mounted in bearings, having applied thereto armed crossheads with curved links attached to the arms and the door shafts.

A worm segment is mounted on each short shaft and the hub of the segment is made with a clutch member having a lug on it. Another clutch member is secured to each shaft and made to co-operate with the lugs on the other clutch members. The lugs in the two clutch members are so proportioned as to permit of relative movements of the segment and shaft. Worms are mounted between the draft sills near the ends of the hopper body and are disposed over and enmesh with worm segments. A transverse shaft passes through the worms for rotating them, and this shaft is mounted near its ends in bearings secured to the side sills. The ends of the shaft project beyond the side sills for the application of a device for manually operating it.

Sprocket wheels are secured to the cross shafts and these sprockets are connected by a chain so that when one or the



Ore Car for the Duluth, Missabe & Northern

side and center sills and bottom cover plate. The upper edges of the diaphragms are riveted to a floor plate which covers the entire portion of the frame from the hopper sheet to striking plate. This floor cover plate is riveted to the end sill angles, draft sills, and side sills, and has a flange at its rear end which is connected to the hopper slope sheet, forming a girder which permits of the buffing stresses being equally distributed over all parts of the underframe.

Secured to and extending from one bolster to the other are longitudinal or sub-sills spaced a short distance from the side sills. These serve to increase the strength and rigidity of the underframe, and also provide a connection for the door bracket hinges and sloping side floor sheets. This sub-sill is connected to the side sill proper.

The door mechanism consists of links suspended from brackets secured to the draft sills at the respective ends of

other of the shafts is rotated, motion will be imparted to both worms for turning the worm gears. When the doors are closed they are kept so by the worm gearing, without the necessity for the use of pawl or ratchet devices. When the sub-shaft has been rotated sufficiently to overcome the dead centers of the link mechanism, the weight of the load in the hopper body forces the doors fully open.

A test was made recently with one of these cars loaded with 52 tons of ore, to ascertain the length of time required to dump the load, one man doing the work. From the time the operator applied the wrench to the operating shaft, including dumping the load and closing the doors, the car was made ready for the return trip to the mines in 35 seconds.

These cars are built under patents owned by the Ralston Steel Car Company and were designed by R. R. Weaver, mechanical engineer of that company.

# EMPTY AND LOAD BRAKE EQUIPMENT\*

Description of Operation in Freight Service;  
Small Air Consumption One of Its Advantages

BY WALTER V. TURNER  
Assistant Manager, Westinghouse Air Brake Company

An "Empty Car Brake," "Single Cylinder Brake," or, to use perhaps the best name of all, "Single Capacity Brake," is the one most generally found in railroad service today. It is one in which a constant braking force is used for all conditions of car loading and one for which the braking ratio is invariably based on the empty weight of the car. With this brake the range in braking ratio will vary as much as from 60 per cent to 15 per cent as the car varies from its empty to its fully loaded weight. It is inevitable that cars braked only one-quarter as effectively as others should close up or pull away, as the case may be, according to the relative positions in the train. That is to say, it is inevitable that slack action—violent slack action—should occur. Some railroads have, in my judgment, foolishly jumped from the

the car is a little more than half loaded without exceeding a braking ratio of 60 per cent for that particular condition of loading.

Fig. 1 shows the way the braking ratio ranges for different conditions of car loading, with and without the empty and load brake. Two ratios between the loaded and empty weights are given, namely, 3.5 to 1 and 4 to 1. The increase in this ratio only means a greater contrast between empty and loaded car braking ratios, and this in turn less uniformity of retardation, with resultant slack action, and less safety of control on mountain grades. If, however, the empty and load brake is installed, it may be cut into load operation with 55.5 per cent loading without exceeding a 60 per cent braking ratio where the weight ratio is 4 to 1, or less, and the corresponding point for a 3.5 to 1 ratio is 53.4 per cent loading.

A line representing a 4 to 1 weight ratio is shown starting from a 40 per cent braking ratio for the empty car and drops to 10 per cent for the loaded car. Where the car is either empty or fully loaded at all times, i. e., having no operation with a partial load, and employs the empty and load brake, this 40 per cent empty braking ratio is most desirable. This lower braking ratio is also desirable for the reason that it minimizes the effect of serial action in the pneumatic application of brakes on a long train. While the 40 per cent braking ratio is desirable for the empty and load brake, a 60 per cent ratio has been applied for the reason that cars equipped with the empty and load brake may be passed to roads which do not have empty and load brakes, and which therefore are not expected to cut the brake into load position.

The empty and load brake also has a tendency to reduce the number of slid flat wheels, inasmuch as more uniform retardation is obtained throughout the train. Slid flat wheels are more frequently the result of the cars being "knocked off their feet," so to speak, by sudden shocks, permitting the brake shoes to lock the wheels and hold them, the static friction between the shoes and the wheels being greater than the kinetic friction between the wheels and the rails. However, even though the car is knocked off its feet and thus the wheels

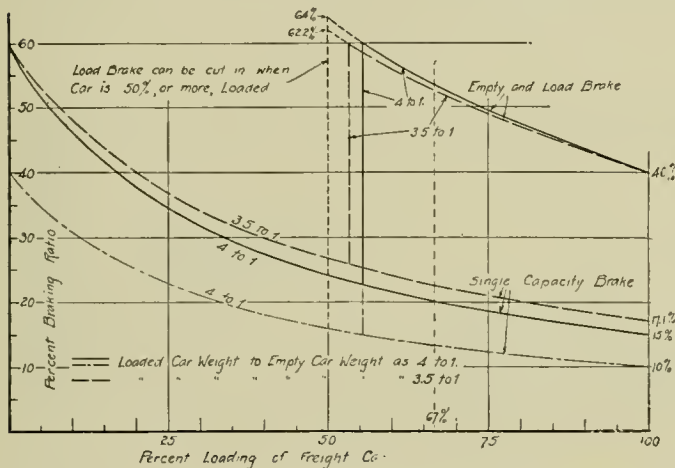

Fig. 1—Chart Showing Braking Ratios for Various Conditions of Freight Car Loading, with and without Empty and Load Brake

frying pan into the fire by increasing the braking ratio on the empty car. This, of course, increases the braking ratio above 15 per cent when the car is loaded, but it is disastrous to braking operations with long trains.

The empty and load brake is one wherein a braking force is used varying with the weight of the car and thereby giving either a constant braking ratio for all conditions of car loading or a ratio much more limited in its variation than in the case of the single capacity car brake. The empty and load brake as designed for freight service has two distinct braking forces due to the operation of one or of two brake cylinders during brake applications. The full service braking force obtained with the one cylinder is 60 per cent of the empty weight of the car, as with the empty car brake. It is used with the empty and partially loaded car. But when the car is loaded beyond a certain point the second brake cylinder is cut into action to assist the first. The total braking force now equals 40 per cent of the weight of the fully loaded car instead of from 15 to 17 per cent with the single capacity brake. The reason 60 per cent braking ratio is not used for the loaded car is that if it were the second cylinder could not be cut in until the car was fully loaded without exceeding the 60 per cent braking ratio. With a 40 per cent braking ratio for the fully loaded car, the load brake can be cut in when

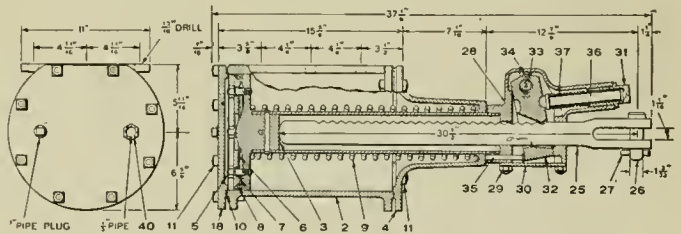

Fig. 2—Load Cylinder, Showing Notched Push Rod and Clutch

slide momentarily, it doesn't always follow that they will continue to slide. For if the pull of the rail on the wheel sliding exceeds the pull of the shoe, the wheel will commence to rotate again and so continue. To slide the wheel from a standstill, or to keep a car off its feet, once it has been knocked therefrom, either the cylinder pressure must be high or the rail bad, or both. Slid flat wheels appear on empty cars much more frequently than on loaded cars.

The shocks being greater with the single capacity brake than with the empty and load brake, it is obvious how prolific shocks may be in slid flat wheels, due to lack of uniformity

\*Abstract of a paper presented before the St. Louis Railroad Club, February 11, 1916.

in braking. And thus the role of the empty and load brake in eliminating slid flat wheels and all the other evils arising from slack action is apparent.

GRADE SERVICE

In grade service the advantages of the empty and load brake are at first glance more apparent. In descending a grade a certain portion of the car weight is acting to accelerate it, and if this acceleration is not to take place, an equal opposing force must be brought into play to counteract the accelerating force. In calculating train control on grades it is necessary to consider the internal resistance of cars, but this is neglected in figuring stops for the reason that many tests have demonstrated that in bringing a car to a stop the internal resistance is just about equal to the force required to overcome the rotative energy of the wheels.

The retarding force set up by the brakes on a car is, in terms of the car weight, equal to the braking ratio multiplied by the brake rigging efficiency and by the coefficient of brake shoe friction. Thus, if a loaded car equipped with a single capacity brake has a braking ratio of 15 per cent, a rigging efficiency of 85 per cent and a brake shoe friction of 15 per cent, the retarding force will be  $.15 \times .85 \times .15 = .01915$  or 1.9 per cent of the car weight. That is, this retarding force will just equal a net accelerating force of 1.9 per cent, or one due to a grade of  $1.9 + 0.4 = 2.3$  per cent, making

flexible, safe and economical the empty and load brake is. This reserve may be utilized by handling a train with the empty and load brake twice as long, other things being equal, as the empty car brake train and with the same factor of safety. In the matter of coming to a stop on a grade, the stop distance will be, other things being the same, inversely proportional to the braking ratio.

A train equipped with the single capacity brake, averaging 75 per cent of the full service braking power (average cylinder pressure 37.5 lb., an assumption really too high), that will run away on the 2.3 per cent grade will be held at a constant speed of 20 m. p. h. with the empty and load brake and with 45 per cent of the full service braking power (average cylinder pressure of 22.5 lb.—a very conservative assumption), and its reserve braking force enables it to stop from this speed in less than 500 ft.

AIR CONSUMPTION

The air consumption in braking a railroad train depends upon the number of cars, the brake pipe and auxiliary volumes for each, and the amount and number of brake pipe reductions used. The freight empty and load brake is so designed that when operating in load position, air is admitted to the "empty" cylinder alone until a brake pipe reduction of about 8 lb. has been completed. The load cylinder is then automatically cut into operation. But the empty cylinder

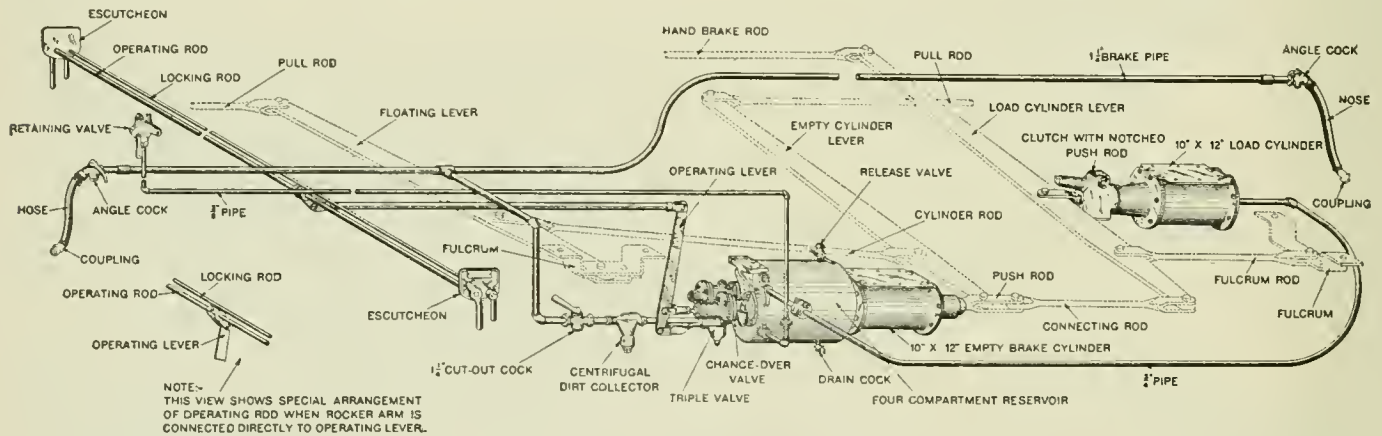

Fig. 3—The Combined Empty and Load Brake

the above allowance for internal resistance. But this would provide no reserve, no margin for safety or flexibility, because it would necessitate a constant cylinder pressure of 50 lb. (the basis for the braking ratio mentioned) all the way down the grade. Leakage, recharging and the ability to come to a stop when desired would be quite uncared for. Considering time for recharging, length of train, reserve power for making a stop, leakage, etc., the cylinder pressure will average only 30 lb. for the entire descent of the grade. This means that the retarding force will be only 30/50 of 1.915 or 1.15 per cent, and the maximum grade corresponding,  $1.15 + 0.4$  or 1.45 per cent. Making the same allowance for the empty and load brake, we find the maximum grade to be  $G = .40 \times .85 \times .15 \times 30/50 + 0.4 = 3.46$  per cent.

These limiting grades stand in approximately the same relation as do the braking ratios for the two types of brake. In each case approximately the same factor of safety holds good. That is to say, the empty and load brake is as safe on the 3.46 per cent grade as the single capacity brake is on the 1.45 per cent grade, the only difference being, as will later be shown, an increase in air consumption of 17 per cent for the empty and load brake.

The empty and load brake will control a train of loaded cars on a certain grade with only one-half the air consumption required by the single capacity brake with the same train on the same grade. This, in itself, shows how much more

has meanwhile taken up all the slack in the brake rigging, the load brake piston not moving at all, due to the use of a special notched push rod and clutch device, until air is admitted to the load cylinder. This cuts down the load brake piston travel to a minimum, making it about 1 1/2-in. instead of the usual 8-in. piston travel. Fig. 2 shows a sectional cut of this device and Fig. 3 the operating mechanism and the relative arrangement of all parts.

Thus, where the two cylinders, the empty and load, are of the same size, the volume of air required for a certain brake pipe reduction is roughly

$$\frac{1.5}{8} = 19$$

per cent more for the two cylinders than for the single cylinder brake, instead of 100 per cent more, as would be ordinarily expected with the use of two cylinders as compared with one. As the empty brake cylinder takes up all the shoe clearance and slack in the rigging, a high leverage ratio may be used for the load cylinder without any of the evil effects of high leverage on the single capacity brake or on the empty cylinder. If the empty cylinder has a leverage ratio of 9 to 1 and the load cylinder force is multiplied 1 1/2 times by the time it comes to the empty cylinder push rod (see Fig. 3), the final leverage multiplication for the load cylinder is  $1 1/2 \times 9 = 13 1/2$ . Thus, if the empty cylinder is respon-

sible for 16 per cent braking ratio with the loaded car, to the load cylinder is due  $1\frac{1}{2} \times 16$  per cent = 24 per cent braking ratio, and the total for both is 40 per cent. This, with the use of the special clutch and notched push rod for the load cylinder as before mentioned, explains briefly why the remarkably low air consumption is possible for the empty and load brake.

The superior air consumption performance and reserve braking force of the empty and load brake may be utilized in several ways. The speed of trains down grades may be increased, the speed restriction or limitation now passing from the brake to the question of wheel temperatures. The length of trains and the loading of cars may be increased or all these increases made and still leave the reserve in air supply and braking force comfortably great; and remember that this means increased traffic capacity, reduced unit costs and correspondingly increased net revenue.

#### RESULTS OF TESTS ON THE VIRGINIAN

Dynamometer car tests made on the Virginian Railway between Princeton, W. Va., and Kellysville, over a 1.5 per cent grade 10.5 miles long, brought out clearly the advantages of the empty and load brake over the single capacity brake. On this grade with a train of 90 loaded cars, 30 of which were equipped with the empty and load brake, these cars being placed at the head of the train, the train was stopped from a speed of 21 m. p. h. while the speed of a similar train composed of all single capacity brakes was reduced to 8 m. p. h. from the same speed with the same brake pipe reduction. Also the average brake pipe reduction required to control the trains was only half as much for the first train as for the second train. The first train was satisfactorily handled at an average speed of 19 miles an hour, whereas the average speed for the second train was only 16.5 miles an hour.

Just preceding the final application at the foot of the grade, with the train having all single capacity brakes, the brake pipe pressure was only 78 lb. instead of 91 lb., as it was to start with. With the similar train having 30 empty and load equipments on the head end, the brake pipe pressure preceding each successive application was maintained at 93 lb., no difference being noticed between the recharged pressure previous to the first application and that just before the stop at the foot of the grade.

Emergency stops from 23 m. p. h. on the grade with trains consisting of one locomotive, dynamometer car, six loaded coal cars and caboose (brakes on locomotive and caboose cut out) were made in an average distance of 1,780 ft., when the cars were equipped with single capacity brakes. A similar train having cars equipped with empty and load brakes was stopped from the same speed in approximately 720 ft., 40 per cent of the distance required to stop with the single capacity brake.

#### TRAP DOORS ON OBSERVATION CARS

A large eastern road recently went into the matter of side gates and trap doors on observation car platforms very carefully and it was decided to provide for the trap door opening first and the gate afterwards. This forces trainmen to open the trap and the gate in going back to flag instead of simply opening the gate and jumping off the platform. Similarly in the case of a trainman trying to reach the platform again after a train has started, it will make it possible for him to make use of the steps instead of trying to climb over the trap door with great risk to himself.

It also safeguards against passengers opening the gates, or leaving them in an unsafe condition when the train is running.

Accidents on account of porters being thrown from a train, caused by the train's starting suddenly, are avoided

because the men have to step down slightly to reach the gate and are therefore held from being swept off.

#### TERMINAL CAR CLEANING YARDS\*

BY R. N. MILLER

The average railway passenger terminal yard is designed for a two-fold purpose, and the way in which this two-fold purpose is satisfied determines the degree of success of the entire layout. The main function of the terminal cleaning yard is, as its name implies, to provide adequate facilities for inspection, repair and sanitation of equipment used in passenger train service. The secondary function is that of serving as a temporary storage or waiting yard for passenger trains after they have been inspected and made ready and before being advanced to the main terminal for the assigned runs. Therefore, a terminal cleaning yard must possess a location that will lend itself readily to train movements and at the same time not involve too great an initial investment. At the same time it should have such a location with respect to the main passenger terminal as to require a minimum of expense in moving trains to and from the passenger terminal or in the rearrangement of these trains, as in their turning, or the redistribution of the cars in the train units. On that account a well-laid-out terminal yard will, as far as possible, provide some means for quickly turning trains, either in the way of a loop or wye. This last requirement involves considerable yardage, and where this cannot be obtained the less convenient and more expensive method of train turning by switching out the cars so as to rearrange their order must be resorted to.

The total number and the length of the tracks required will depend on the nature of the train schedules to be met and the general class of trains to be handled. Through line trains, with their quota of sleepers, diners, chair cars, day coaches, baggage and mail cars, demand more attention for inspection and refitting than suburban trains intended to handle commuter service only. It is always desirable that a terminal cleaning yard be so laid out that all trains can be placed without resorting to breaking them up, due to inadequate trackage facilities, a condition which, of course, must always be accompanied by additional switching, with its tendency toward increased expense, congestion and confusion. In this way, where the layout is such that tracks are of unequal length, the longer train units would have to occupy the greater lengths of track while the shorter units would be distributed among the lesser lengths, a condition which would sooner or later greatly limit the capacity of the yard. Again, where the layout is such that all tracks are of approximately equal length and amply provided to accommodate trains of maximum length, each track could be operated to best advantage when short train units are met by placing two or more such units on each track and arranging them in the order of their departure.

Where the terminal yard is to serve only as a cleaning and inspection yard and where some intermediate storage or advance waiting yard is provided, the amount of trackage required will depend upon the nature and extent of work or repairs done at the cleaning yard as well as the size and frequency of trains to be handled. From the foregoing it will be seen that such requirements as charging up of storage batteries, renewal of batteries, repairs to axle light equipment, charging of gas tanks, replenishing of diners, sleepers, etc., will add materially to the time required for the simpler operations of coach cleaning: washing and dusting. On this account the time element becomes a very potent factor in the number of trains handled per track.

A cleaning yard, to successfully meet the requirements of modern train service, must also, therefore, provide ade-

\*Entered in the Car Terminal Competition.

quate facilities for emergency and light repairs as well as for sanitation purposes. In this way it is possible to return equipment to service in perhaps shorter time than if it were necessary to send the equipment to the nearest general repair shop.

The yard layout should, first of all, include thorough drainage, both surface and sub-surface, so as to prevent the accumulation of pools from the wash water from the cars resulting in general untidiness of the yard and being detrimental to the health of employees. To facilitate the washing down of cars a liberal supply of water spigots should be provided so as to reduce to a minimum the distances which water must be carried. All spigots should be thoroughly protected against freezing and on that account should be of the self-draining type. Steam heat connections should be distributed so that all train units can be properly pre-heated and in such locations with respect to the tracks that connections can be readily made or broken. Adequate protection should be provided for both the hose and pipe connections, against injury due to accidental moving of trains while still coupled to steam lines, a good plan being to provide for such steam connections at the track bumping posts and every 250 ft. to 300 ft. therefrom, with connections located between the rails.

Air outlets or connections should be liberally distributed, for in cleaning yard work compressed air is much used in cleaning as well as testing. These outlets should be so distributed as to make it necessary to use more than 75 ft. lengths of hose connection or to require hose to be dragged across the tracks in order to get at the air supply outlet. In other words, air outlets should be located between every second pair of tracks and at intervals of not over 50 ft.

Pintsch gas connections should be located at about the same points as air connections so as to insure ease in charging of cars when placed at any point in the yard. A preferable location for gas lines is above the surface of the ground and generally along the outside of the running rails.

Battery charging connections should be provided at frequent intervals, depending upon the length of the cars to be served and their position in the train units. The more usual practice is to locate these at approximately the same intervals as the air connections, making provision against grounding due to dirt and surface water. These connection receptacles should be of the flexible type so as to prevent damage when connections are pulled out by accidental moving of the trains while the batteries are still being charged. Again, each battery charging outlet should be located on an individual circuit so as to provide means for individual control of the charging of each battery at the charging switchboard located at the charging room of the power plant.

Where vacuum cleaning of coach seats, etc., is to be done, provision must be made for vacuum connector outlets where the system employed is of the central plant type. In that case, since the efficiency of a vacuum system falls rapidly with the increased lengths of hose connections, it is advisable to keep these down to reasonable limits, and outlets should therefore be distributed about as frequently as the compressed air outlets—every 50 ft.—and should be of a type which will hold tight at all times so as to prevent the failure of the vacuum due to leakage. Where the portable type of vacuum cleaner units is used, that is, the electric-driven portable unit, electric connections can be obtained at the same points as are used in the charging of batteries. In that case the portable units will have to be direct current machines, while the unit used in the central plant system could be either direct or alternating current.

Trunk line feeders for steam, air and battery charging outlets should be carried in conduits so constructed as to afford easy inspection at all times. These conduits should be self-

ventilating on account of steam leaks and on account of possible stray gas leaks from outside gas lines; well drained to prevent accumulation of water on the conduit floors and with roofs of the removable slab type, the slabs being heavily reinforced concrete to sustain the loads due to the trucking of material about the yards. Steam trunk lines in conduit work should be amply protected against expansion and contraction strains, generally by means of the slip joint on account of limited clearances. All steam trunk lines and laterals should be well lagged.

Laterals for both steam or air should be well protected with reliable stop valves to avoid inconvenience due to delays on account of failure of one of the laterals, such as might come about by the tearing off of a connection through accidental moving of a train which was still coupled to the line. With the thorough lagging of steam lines there is but little radiation, and on that account air lines located in the same conduit need not be provided with expansion joints. All conduit work for the battery charging circuits should avoid sharp bends or turns where difficulty would be met in installing the lines. Junction and distributing boxes should be placed so as to avoid long pulls in wiring up.

Passageways between tracks where traffic is to be found should be well paved with brick, concrete or creosote blocks so as to provide good means for the transporting of heavier materials and supplies. The latter may be carried out satisfactorily by means of small electric trucks. The small industrial railway is not flexible enough to give good service in a car cleaning yard, and is therefore not considered.

All buildings used in connection with the car cleaning yard should be thoroughly fireproof and sanitary. As a result of the location of buildings being left to the later stages in the development of a yard layout, they are usually placed at one side of the yard proper. This involves more inconvenience in the securing of supplies than would be found where the buildings are centrally located; again, since the yard site determines the nature of the entire layout, the initial cost and final yard facilities often determine the ultimate location of the buildings. In this way it can be seen that each layout, in itself, presents problems which can only be dealt with as individual problems and then only on the basis of final cost.

## COACH WINDOW RAISER

BY C. C. LEECH

The material used in the coach window raiser, shown in the illustration, is all hard wood with the exception of the steel pin holding the handle in the clevis *C*. The end *A* of the lever on its upper side may be covered with plush or other soft material and also the under side of the clevis, to prevent scratching the varnish or woodwork of the window sills in

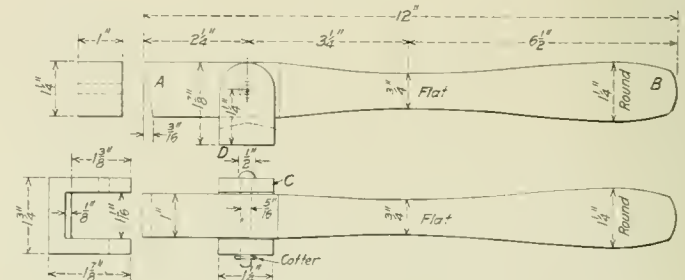

Window Raiser for Coaches

the cars. The manner of using the raiser is to place the end *A* under some protruding part or attachment on the lower frame of the window, and resting clevis *A* on the sill to bear down on the handle at the end *B*. It will not fail to start the most difficult window.



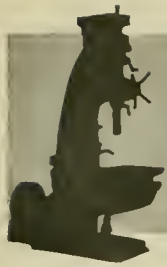

# Shop Practice



## MATERIAL DELIVERY AT THE MACON SHOPS

BY G. W. ALEXANDER  
Division Storekeeper, Central of Georgia, Macon, Ga.

At the Macon, Ga., shops of the Central of Georgia, where there are about 1,300 employees, all material is delivered by two delivery boys, who are paid .07c. per hour, and one laborer, who is paid 12½ cents per hour.

Small boxes are placed in the shop buildings at convenient places, and when material is needed the shop foreman needing it writes a storehouse ticket and drops it in the box. At ten minute intervals the messenger boys call at each box, collect the tickets and deliver them to the storehouse. At the storehouse we have a foreman and two laborers who get up all material, placing small items such as cotter keys, nuts, machine bolts, etc., in thick heavy paper bags and indicating on the bag the point in the shop where material is to be delivered, foremen having instructions when writing tickets to indicate on the ticket the engine number, or the name of the machine to which the material is to be delivered.

If when a ticket is presented at the storehouse it is found that we are out of the particular class of material called for, the foreman issuing the ticket is notified and information given him as to the nearest material that can be substituted. If in the foreman's opinion a substitution can be made he changes the ticket accordingly; otherwise the ticket is destroyed by the foreman issuing it. This overcomes the possibility of the storehouse receiving a ticket and not delivering the material, as the foremen require us to either return the ticket or deliver the material called for. This feature is of great assistance to the storekeeper, as the foreman notifies him promptly if any material is out of stock, and it is ordered at once, or if already ordered, it is traced for immediate delivery.

In addition to the messenger service used in delivering material from the storehouse to the shop, we also employ the boys between the machine shop, boiler shop, blacksmith shop, roundhouse and car shop, in carrying certain information from one foreman to another, or in going from one shop to another, getting material which is being worked on at some particular machine, and delivering it wherever it is required. These messengers are encouraged by giving them apprentices' places in the different departments of the shop when an opening occurs, and when a boy is used in messenger service, he familiarizes himself with all machinery and material; consequently when he is made an apprentice in the shop, he is of much more assistance than a boy who has just started in the shops, without the previous experience as a messenger. This also saves quite a bit of material which would be spoiled by an apprentice who had not had the previous training.

We have found from experience that without the messenger service, or an automatic telephone service, considerable time is lost by mechanics sending their helpers to the store for material, and waiting for the material until the helper returns; or that a high-priced mechanic is sent to the store for material, incurring an unnecessary expense in either case because of lost time. With the messenger system the foreman looks ahead as to the material needed by his mechanics

and sees that it is provided before it is actually required.

I also believe that the messenger service is superior to the automatic telephone system. In the first place, the installation of the telephone is very expensive, and after installed it requires quite a number of employees in the storehouse to answer all calls. Then in some cases the conversation is misunderstood, and material is delivered erroneously; but where a ticket is written and dropped in the box, and taken up by a messenger, there is very little chance for mistakes in delivery.

This system has been in effect at the Central of Georgia storehouse and shops at Macon for the past eight months, and we have found it very satisfactory and economical.

## A RECLAIMED RAIL SAW

BY E. T. SPIDY  
Shop Engineer, Canadian Pacific, Winnipeg, Man.

The frog department at the Winnipeg shops was in need of a friction cut-off saw with which second-hand rails could be cut quickly and so that delays in getting quantities of rails cut at various angles would not occur. The machine described herewith was made probably for less hundreds of dollars than the number of thousands of dollars which would have been required to buy a new machine, and it is con-

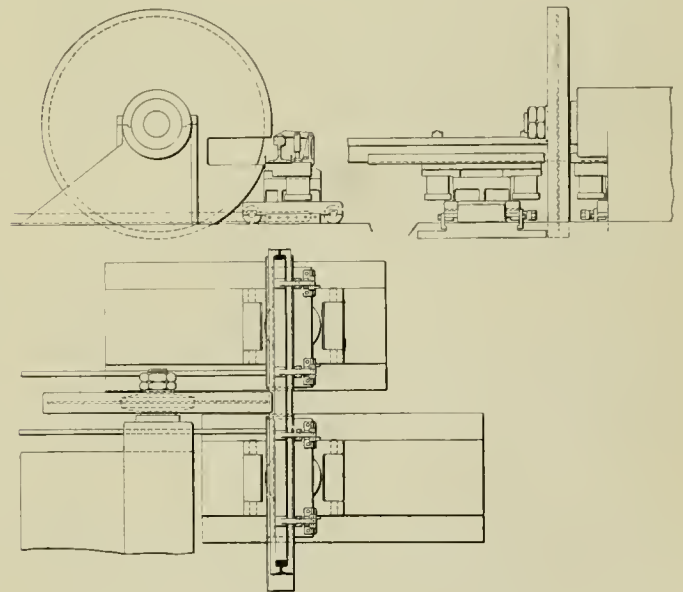

Arrangement of the Saw and Carriages

sidered equal in every way to any other type of friction saw.

The main bearing for the saw shaft was provided by using a heavy tailstock from a scrapped driving wheel lathe. This casting was set on a foundation below the floor level, so that the center of the bearing was 22 in. above the floor level. Split bushings were placed in the bearings and babbitted to suit the 6-in shaft which was turned out of an old axle. On one end the shaft carries the saw, which is made from 1¼-in.

boiler plate, and a 16-in. belt pulley is placed on the other end. The shaft runs at a speed of 2,800 r. p. m. Two base plates are bolted to the foundation to form the runway for the rail carriage, which is pulled into and out of the saw by means of a 10-in. air brake cylinder bolted on the floor at the rear of machine. These base plates are from the tool carriages of the scrapped wheel lathe. The two carriages which have been built to run on the base plates each have two 4-in. air cylinders bolted on the under side, the pistons of which are connected to levers which clamp the rail on the carriages. The angle at which the rail is cut is adjusted by changing the relative position of the two carriages. This is

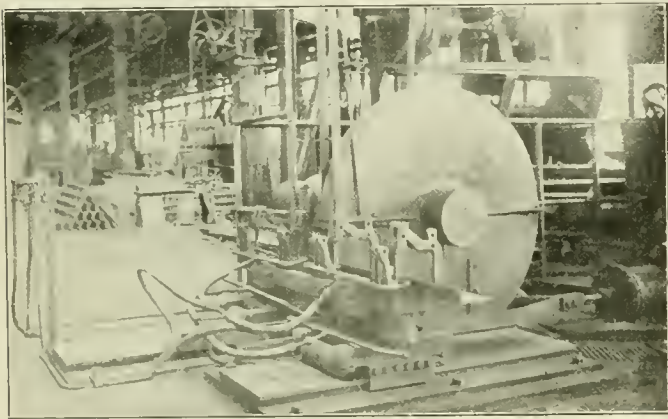

A Rail Saw Built from an Old Wheel Lathe

done by adjusting the length of the connecting bar from the brake cylinder to one of the carriages. The rail-clamp top plates are then turned and locked at the desired angle. When in operation the saw is cooled by a stream of water, the pipe entering the hood over the saw as shown in the photograph.

The actual cutting time with this machine is less than 30 seconds for one 85-lb. rail. The operator stands about five feet away from saw by the two four-way cocks at the left of the photograph. One cock controls the rail clamps and the other the feed in and out of the saw. A 75-hp. motor provides all the power needed.

### FITTING DRIVING BOX BRASSES

BY V. T. KROPIDLOWSKI

The finishing of driving box brasses and fitting them to the boxes on a slotter is the quickest method known to the writer, and when the operator is provided with suitable tools and gages the work is perfectly accurate. By the use of the gages shown herewith the work may quickly be laid out, and when the machine operations are complete the brass is ready to be applied without further fitting.

The inside calipers shown in Fig. 1 are very flexible and are capable of three independent adjustments. The two contact points *C* are 4 in. long. These contact points are secured to the arms *M* with 3/32-in. pins inserted through the lugs *O* and the flattened ends of the arms *M*. The other ends of these arms are also flattened and secured in the jaws of *N* with 3/32-in. pins. The stem *L* is 1/2 in. in diameter and to its end is soldered a contact bar, *F*. This bar also has a 4-in. bearing against the top of the brass fit in the box, the same as the contacts *C*. A 1/16-in. key-way is cut the entire length of the bar *L* and a feather with gib heads is fitted in the hub portion of *N* to keep *F* in the proper position at all times. The calipers are adjusted by means of the thumb wheels *B* and the hand wheel *D*.

When the calipers are inserted in the box and adjusted to size, the gage *E*, Fig. 1, is set to the calipers at the three points *C*, *C* and *F*, the sliding clips *P* being adjusted to the

level of the toe of the brass and clamped by the thumb screws *A*.

A chuck for holding the brasses is shown in Fig. 2. It is clamped to the slotter table, the projection *K* fitting into the

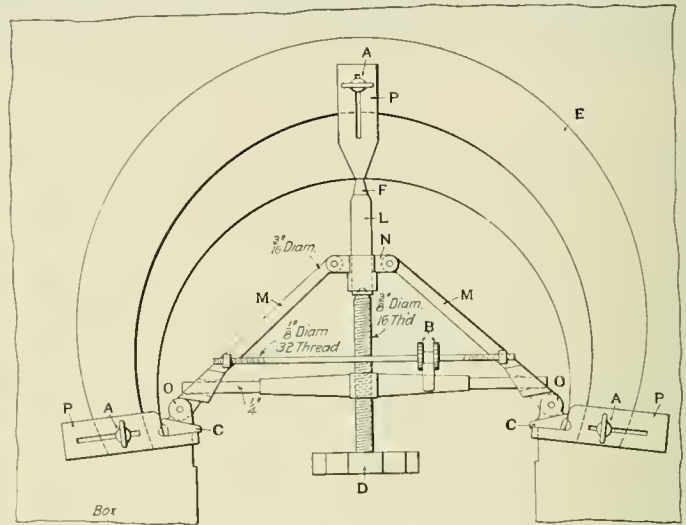

Fig. 1—Caliper and Gage for Laying Out Shoulder Fit on Driving Box Brasses

table center. In a piece of 1-in. pipe *G* is fitted a coil spring which presses against the bottom of the plunger *H*, and keeps the top head *I* up in position at all times.

Fig. 3 shows the tool post used in the slotter. It is made

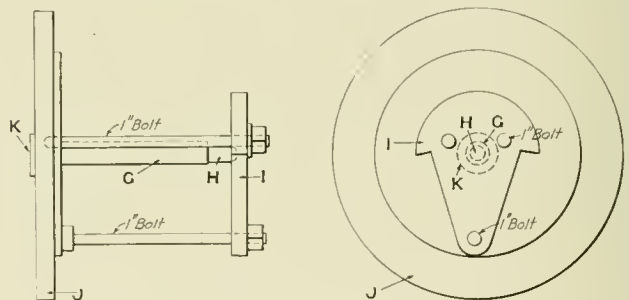

Fig. 2—Chuck for Clamping the Brass on the Slotter Table

in two parts, the upper piece *R* having a slot in its lower end, into which fits a tongue on the lower piece *Q*. The latter is pivoted about the pin *S*, the shoulders of the slot being slightly relieved at *T* to allow the tool to swing back on the

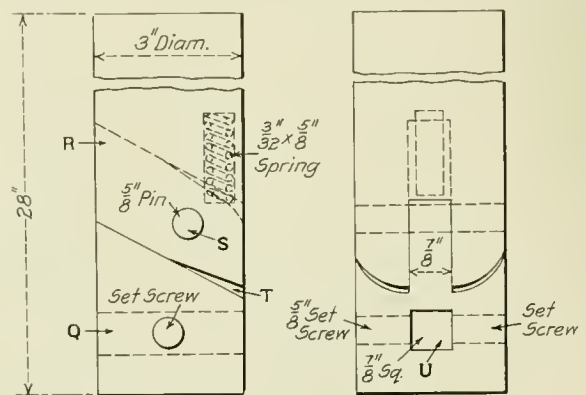

Fig. 3—Slotter Tool Holder

return stroke of the slotter. The tool is inserted into the square hole *U* and tightened with set screws.

As the boxes come from the lye vat, they are examined by

the machine foreman who marks the brasses to be removed. When they have been pressed out the slotter man takes a sheet-steel template (see Fig. 4), of which he has an assortment made from the drawings of the driving boxes for the various classes of engines, and tries it in the box to see how much it is spread. He then lays the template on the rough brass and scribes around it, allowing, by eye, for the amount the box was found to be spread; this operation merely serves to facilitate the centering and setting up of the work in the slotter. He now calipers the box and finishes the brass with one cut. While he is taking the cut he inserts the inside calipers into the box and adjusts them just so they can be slid up and down. The brass fit in the box always tapers slightly,

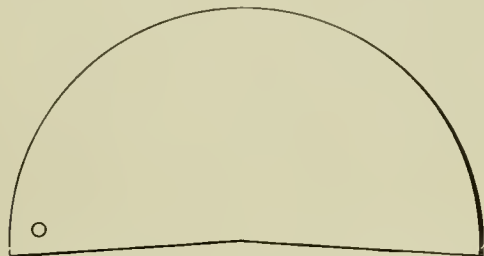

Fig. 4—Template Used in Centering the Brass on the Slotter Table

due to the slotter tool crowding away from the work. By sliding the calipers up and down in the box, he ascertains which end is the largest and then adjusts the calipers snugly at that end. Having this done, he lays the gage *E* on the box and adjusts the clips to the inside calipers. When the clips *P* are adjusted they give the angle of the retaining shoulders, which may be transferred directly to the finished brass and scribed thereon. The ends of the brass are then finished to the lines, which completes it ready for pressing in.

There needs never to be done anything more to the brass, as the ends fit perfectly against the retaining shoulders in the box. The whole operation is being completed in a half hour, including pressing in the brass and all other work pertaining to it.

## WASTE AND ABUSE OF BRASS AND BRONZE

BY RUSSELL R. CLARKE

Brass and bronze are probably the most expensive classes of material used in large quantities in railroad service. During the year 1915 one large railroad system consumed 8,750,000 lb. of brass and bronze castings at an approximate cost of \$1,050,000, and when it is pointed out that this cost represents only the rough castings, taking no account of the cost of finishing and applying, the large expense involved will be readily understood. Few persons aside from the actual buyers and producers of this class of material have an adequate understanding of its high cost and it is of interest to note that finished castings may cost anywhere from 5 cents to 25 cents per cubic inch. The magnitude of the loss which may result from the abuse of these materials should therefore be evident.

While the value of scrap material is approximately 80 per cent of the price of the new material, the fact should not be overlooked that there is a limit to the use of scrap material in producing new castings. The proportion of new material should never fall below 30 per cent and for the best results should not be below 50 per cent of the total.

Copper base alloys may usually be divided into four classes, depending upon the purpose for which they are to be used. These are ornamental, steam or pressure metal, bearing metal and bell metal. Yellow brass is used principally for ornamental purposes and is made up of approximately two parts of copper to one part of zinc. Small proportions

of tin and lead—from one-half to one part of each—are frequently added. A still smaller proportion of aluminum is also sometimes added. German silver and statuary bronze, which are sometimes used for ornamental purposes, have approximately the following constituency: 50 parts copper, 25 parts nickel and 25 parts zinc, and 84 parts copper, 4 parts lead, 2 parts tin and 10 parts zinc, respectively.

Steam or pressure metal, usually known as red brass, is an alloy in which copper, lead, tin and zinc are all used, opinions differing widely as to the proportions to be maintained. Table I shows a number of these alloys, all of

TABLE I—PRESSURE METAL ALLOYS

Copper	Tin	Lead	Zinc
85	5	5	5
86	3.5	3.5	7
86	3	8	3
86	3	5	6
84	4	6	6
88	10	...	2

which contain 85 per cent or more of copper. The last alloy shown, although expensive, is one of the best known, being noted principally for its strength.

The bearing alloys are generally made up of copper, tin and lead, in which small percentages of phosphorus and nickel or ferro-manganese are used. The phosphorus acts as a purifying agent while the use of nickel or ferro-manganese aids in securing a more homogeneous distribution of the lead content. Zinc is unsuitable for use in bearing metals because of its tendency to cause adhesion and heating. The proportions of a few of these alloys are given in Table II. The two mixtures last shown are known as

TABLE II—TYPICAL BEARING METAL ALLOYS

Copper	Tin	Lead	Phosphorus	Nickel	Ferro-Man.
79	10	10	1	...	...
77.5	8	14.5	...	...	...
78	10	12	...	...	...
65	4	30	...	1	...
70	6	23.5	...	...	.5

high lead alloys, the successful control of that element in such large proportions being a difficult matter in the foundry. When bearings of such material run hot in service, pure lead will often ooze out of the casting, showing that it was imperfectly alloyed with the other elements.

Ordinary bell metal is usually about 80 parts copper and 20 parts tin, to this from .5 to 1 per cent of antimony is sometimes added to increase the hardness and improve the tone. Another mixture which is often used is five parts copper and one part tin.

The functions of the various elements may be briefly summarized as follows: copper furnishes body; tin hardens and strengthens the alloy; lead closes the grain, adds plasticity and facilitates machining while zinc purifies and toughens the alloy. In yellow brass the zinc is responsible for the color.

In railroad service brass castings usually seem to be expected to withstand the same kind of treatment that is accorded to iron and steel. The functions of this metal are of an entirely different and more delicate nature than those of iron and steel and it may easily be damaged by treatment which would be entirely suitable for the stronger metals. Brass or bronze which has been injured by rough or improper handling may not give any evidence of its weakened condition. The surface of a bar of iron or soft steel which has been subjected to sharp bending will always indicate the stress to which the material has been subjected, whereas a bar of brass will often show no visible effect of such treatment. To batter an iron nut with a hammer will merely disfigure it, whereas the weakening effect on a brass nut can never be correctly judged.

One of the characteristic physical properties of brass is

its extreme brittleness when heated. Heating followed by immersion in water, however, softens and increases its malleability, while pounding hardens the material and produces brittleness, thus reducing its power of resistance to shock and strain.

If 100 lb. of ordinary brass were to be carefully melted, then cooled and re-weighed it would be unlikely that more than 98 lb. of material would remain. The loss is occasioned by oxidization and volatilization. The total loss in handling, including the melting, ranges from 3 per cent to 7 per cent, varying with the nature of the alloy, the class of work and the shop practice. The cause for the melting loss will be found in the difference in fusing temperatures of the various constituents of the alloy. The melting point of copper is 1,083 deg. C. while that of tin is 232 deg. C. Lead melts at 327 deg. C. and zinc at 420 deg. C. This means that the three low degree elements must be subjected to the melting temperature of the copper.

Casual inspection of the accumulation of scrap on most any railway system will indicate the extent to which brass castings are abused. The writer has personally examined much such material and found the evidence all too plain: a battered and fractured nut, a split or flattened thread, a bent handle, a bruised seat, a shapeless orifice, etc. Probably 50 per cent of the men opening and closing valves either do not know or do not care how to properly manipulate them. It is not unusual to find a brass valve screwed down so tight that it is impossible to open it by hand. When a valve takes its seat and the slack in the threads is taken up it cannot be closed any tighter by jamming it with brute strength. By using a hammer, lever or wrench, the threads will be strained, the seat bruised or the stem bent or twisted. Another source of unnecessary valve wear is the common practice of riding the hand-wheel when operating it. By so doing the gland and stuffing box nuts are worn and the stem thrown out of line.

A wrench should always be supplied and invariably used with spanner nuts. Instead, however, a hammer and chisel are often used to tighten them, their life thereby being very much reduced. Careless handling of car journal bearings is also a source of considerable loss. These are brass castings faced with a white metal lining, the bond of attachment between the two metals being far from infallible. At best it is no more than is necessary to insure adhesion under careful handling and the shocks and jars attending careless handling too often lead to future trouble in service. This condition is appreciated in the foundry, but apparently little attention is given to it elsewhere. Another needless injury which these brasses suffer from careless handling is the nicking and gashing of the bearing surface of the metal lining. In these cavities dust is deposited which, when mixed with oil, often results in a cut journal, a hot box and a ruined bearing.

Under normal conditions the copper-tin-lead alloys are reasonably strong. At high temperatures, however, they become fragile and fracture very easily. The higher the temperature of the metal the more adhesive it becomes and the less effective is the lubricant.

Aside from the physical abuse of brass or bronze parts there are many other ways in which this class of material is wasted. The unnecessary use of steel or iron screws, rivets or pins instead of brass or copper in a brass casting reduces the value of the scrap material. The casting cannot be remelted until the steel has been removed and this is often a task so tedious and expensive as to practically destroy the value of the material. The rejection of castings for minor defects not affecting their serviceability is also a source of waste. There is no doubt but that inspectors are justified in rejecting many castings which the foundry considers serviceable. On the other hand it is equally certain that many

others which are rejected could be used. A crown brass for instance, with a small cavity in the top the extent of which is entirely visible from the surface, may be perfectly satisfactory from a service standpoint. And yet, inspectors often reject such castings simply because the cavity barely clears the finishing limit. Remelting always causes a loss and whether he thinks so or not, the consumer is the ultimate sufferer.

Another source of waste lies in the excessive stock which is left on rough castings. Ordering bushings, rod brasses, crown brasses, etc., from patterns with sufficient stock to cover two or three different finished sizes is a much more expensive practice in the foundry than making separate patterns for each size. Moreover the cost of finishing will be less with the latter practice. Considerable saving may also be effected by the judicious use of cores wherever possible instead of casting the metal solid.

Aside from ornamental brass and bell metal, the service requirements for alloy metals are practically identical on all railroads. There must, therefore, be one set of alloys, or a limited range of alloys within which all specifications should be kept, that will answer all requirements. Railroads now purchase these materials under specifications but the scrap is not disposed of in that way. Junk dealers and reduction companies buy worn out brass castings, the analyses of which are entirely unknown. Large quantities of such castings of varying constituency are melted up, pigged and then sold under specifications according to the analysis of the remelted metal.

It will be noted that copper, tin and lead are common to both steam and bearing metals while zinc is used in the former but not in the latter. In buying the secondary pig most foundries desire to secure it with as low a zinc content as possible, thereby increasing the range of usefulness of the metal. Specifications, therefore, usually call for a zinc content not to exceed one-half of one per cent and reduction companies find it desirable to get rid of the zinc in the scrap material. This is done by raising the temperature of the liquid mass above the volatilizing point of the zinc and holding it there until the zinc is eliminated. At a price of about 19 cents per pound, some idea of the loss involved may be obtained, not to mention the loss of the other constituents.

It will readily be seen that if all worn out castings of steam pressure metal were classified separately from those of bearing metal and that the constituency of each class was within certain standard limits of variation, this loss could be eliminated.

CLAY FOR BABBITTING.—Anyone having much babbitting to do knows what trouble it is to keep the clay of the right consistency for "mudding up" when pouring. The use of ground asbestos mixed with engine oil is reported by J. M. Ericson to give fine results. It never gets hard and is always ready for use.—*American Machinist*.

LOW-GRADE FUELS IN PRODUCERS.—It is pointed out in a paper recently published by the Bureau of Mines that within the past five or six years marked progress has been made in Europe in the utilization of various kinds of refuse material not ordinarily given much consideration. The manufacturers of gas producers report the successful use of a large variety of fuels, including wood shavings, wood blocks, sawdust, excelsior, coffee husks, rice husks, cocoon shells, straw and spent tan bark. The figures on fuel consumption reported by the manufacturers are about as follows: With reasonably dry wood (say mixed oak, ash and elm) the consumption has been as low as 2 lb. per b.hp.-hr.; with sawdust the consumption averages 3½ lb. per b.hp.-hr.; and with spent tan bark containing 50 per cent moisture it is about 4½ lb.—*American Machinist*.

# SANTA FE APPRENTICE CONFERENCE

This Company Has Almost a Thousand Apprentices. 83% of the Graduates Remain in the Service



One of the distinctive features of the Santa Fe apprentice system is the annual conference of the instructors; this year the meeting was held at Topeka, Kan., May 25, 26 and 27. At these meetings the instructors are addressed by various mechanical department officers, and the important questions arising throughout the year are discussed under the direction of F. W. Thomas, the supervisor of apprentices. This year the conference considered more particularly the system of training freight car carpenter apprentices and boilermaker apprentices. Both of these subjects are so important and the discussions were so valuable that they have been made into two separate articles which will be published in the August issue of the *Railway Mechanical Engineer*. This article deals more particularly with the general problems which were considered at the conference.

The Atchison, Topeka & Santa Fe has the distinction of operating the most successful apprentice system in the United States. On May 31, 1916, this road had 974 apprentices enrolled, these being distributed among the several trades as follows:

Machinists .....	554
Boilermakers .....	135
Blacksmiths .....	20
Car builders and coach carpenters .....	25
Freight car carpenters .....	148
Tinners, coppersmiths and pipe fitters .....	36
Painters .....	16
Upholsterers .....	4
Electricians .....	5
Special course apprentices .....	31
Total .....	974

During the past month 20 apprentices were graduated; total graduated for the 12 months ending May 31 is 176. The success of the work in developing apprentices on the Santa Fe is perhaps best shown by the number of graduates

remaining in the service of the company. At present 604, or 72 per cent of all the apprentices, graduated since the re-organization of the apprentice department, September 3, 1907, are on the company's payroll. These figures, however, do not truly represent conditions as they are today, for the percentage of apprentices graduated the first two years after the new system went into effect, because of the earlier graduates not having received the full benefits of this system, is much lower than in the succeeding years. The following table gives a better idea of present conditions:

Year	Graduated	Per cent in service
1912.....	95	74
1913.....	114	74
1914.....	127	87
1915.....	143	94
Total .....	479	83

In the eighth annual report of the supervisor of apprentices it is shown that 99 of the graduates have been promoted to responsible positions, and of these 34 were promoted during the year 1915.

The plan adopted by Mr. Thomas for conducting the apprentice instructors' conferences is unique. As each different subject is discussed by the meeting, the conference is presided over by an instructor who is particularly interested in the subject. He is not required to present a paper, but simply to act as a moderator, asking pertinent questions of the other instructors regarding the subject under discussion.

The instructors were welcomed to Topeka by M. J. Drury, shop superintendent at that place. He spoke of the effectiveness of the apprentice department, stating that at the Topeka shops it has been unnecessary to go outside of the shops for machinists during the past two years, the new

help required being recruited from the graduate apprentices.

ADDRESS BY F. W. THOMAS

Mr. Thomas, the supervisor of apprentices, in his annual address, stated that a number of the older instructors had been promoted during the year.

Every few days greater demands are made for men for various places, men for better places, men to fill positions caused by promotion or retirement of some of the older officers.

During the past year seven of the graduate machinist and boilermaker apprentices were selected for a special course at the Baldwin Locomotive Works, where they have been made assistant department foremen, being transferred from one department to another at least every two months, and every opportunity being offered to give them all the experience possible in these shops. Four graduate cabinet maker apprentices were sent to the shops of the Pullman Company for similar experience. Recently two other young men were sent to the Pullman Company, these being graduate painter apprentices who were selected in order that they might gain experience in the painting of steel cars, particularly in graining steel so that it will resemble a piece of polished wood. Within a day or two Mr. Thomas said he expected to leave for Pittsburgh, Pa., to take four young men who had shown special fitness for air brake work to the Westinghouse Air Brake Company. Mr. Thomas also impressed on the instructors the importance of more care in the selection of young men who were to be sent out in training for these special duties.

Another of the Santa Fe apprentice boys has, since the last meeting, won the Ryerson-Master Mechanic scholarship at the University of Illinois. Mr. Thomas discussed the recent competition for the next Ryerson scholarship and urged the instructors to keep several boys prepared for competitive examinations, as more scholarships are being offered and he hoped that some day the Santa Fe itself would offer scholarships to a few of the most deserving of its young men. He pointed out also the great value to be obtained at college by a young man who had first served his apprenticeship.

During the past year more of the graduates have been promoted to foremanships than ever before and several of the older instructors have been promoted to better positions. Many roads have had difficulty in securing competent men for federal valuation work; the Santa Fe has had no difficulty whatever in filling these places, and the Government officers have especially complimented the road on the high quality of the men who have been so readily selected for this work.

MR. PURCELL PRESENT

John Purcell, assistant to the vice-president and in charge of the mechanical department, spent all of Friday and part of Saturday at the conference. Mr. Purcell gave the instructors considerable encouragement in their work, promising them all the support necessary to make it a success. He laid special stress on the necessity of giving the apprentices *all the experience* possible to be obtained in their various trades. He commented also on the importance of the apprentices having knowledge of the instructions in the Locomotive Folio, a book containing sketches and other information covering standard practices to be followed in repairing locomotive equipment. He cited several incidents showing the importance of following established standards; among them was an instance concerning flue failures on a certain portion of the system. The locomotives were having chronic trouble with the flue leakage and upon investigation it was found that at one end of the division on which these engines

ran, the boilermakers were using beading tools of a certain contour, while at the other end of the division the boilermakers used beading tools of a different contour. Every time the flues were beaded the metal was worked out of the bead to the extent that it was impossible for the flues to remain tight.

Mr. Purcell encouraged the instructors carefully to consider any new ideas submitted by the apprentices, or by any of the other workmen in the shops regarding labor-saving devices or more economical methods of doing the work. In every case, however, care should be taken to give proper credit for these ideas.

In his various talks at the meeting, Mr. Purcell displayed great interest and intense faith in the entire apprenticeship scheme, giving to the instructors the benefit of his years of experience and inspiring them with a knowledge of what could be accomplished and what the management was expecting of each of them in the training of apprentices.

CO-OPERATION OF LOCAL OFFICERS

F. E. Myers, apprentice instructor at Clovis, New Mex., presided, opening the discussion as follows: There is one thing on which we will all agree and that is we will not have a successful apprentice department unless we do have co-operation from the local officers. The main thing to remember when we go to the officers and ask for their co-operation is that these men are in charge of the shop and if our ideas and methods will not help them they are not going to be very enthusiastic about co-operating with us.

The instructors agreed that in order to be successful it is very important to be on the best of terms with all the local officers. Many suggestions as to how to gain the confidence of the foremen and how to keep on good terms were offered. Each foreman must be studied and a method for individual co-operation found. All differences between the apprentice department and the shop foremen should be handled with them direct, and never over their heads without giving them a chance to right matters themselves. No partiality should be shown in dealing with the foremen. An effort should be made to talk with each of them about his work and particularly how the apprentice instructor may help him. A regular meeting of the local apprentice board, at which all apprentice matters are thoroughly discussed, was shown to be an important factor in securing this co-operation.

Where trouble is experienced in getting the boys changed it is usually adjusted by sending a letter to the general foreman with a copy to the master mechanic and the supervisor of apprentices, stating what changes are desired. Few instructors reported any difficulty in securing co-operation of the foremen and all reported the heartiest co-operation of the master mechanic and the mechanical superintendent. They particularly appreciated the interest taken by the higher officers, and reported that the master mechanics were visiting the school rooms more and more and never failed to show the apprentice school to visitors from other roads, thus indicating an interest and pride in what the apprentices were doing.

Following the discussion of this subject Mr. Thomas read a personal letter from J. R. Sexton, mechanical superintendent at La Junta, Colo., in which the latter expressed his appreciation of the good work being done by the apprentice instructors and apprentices. In his territory he had not employed a mechanic for over two years without first trying to secure a graduate apprentice to fill the vacancy. For two years past 100 per cent of his graduates had remained in service. He now has a total of 14 graduate apprentices holding official positions in his territory, many of these important, such as division foreman. He attributed the success of the apprentices and graduates to the careful selection of boys in the beginning; thorough investigation and

elimination during the probationary period, or afterward, if necessary; investigation and adjustment of any charges of mistreatment or mismanagement; giving the graduates full journeyman rate immediately upon graduation; and considering the desires of the young men themselves when making transfers. There is not a point in his territory but has graduates working in some capacity, and at nearly all points the more important jobs of machine, bench, and erecting work are handled by the graduates, with a full quota of graduates in the roundhouses.

#### LIVING UP TO STANDARDS

C. W. Smith, apprentice instructor at Needles, Cal., presided. It was pointed out that the eight or nine years of experience in training the apprentices had resulted in the adoption of certain standards for handling particular questions, and the instructors were urged to live up to these standards. The supervisor of apprentices explained that he had given the instructors a great deal of liberty in dealing with apprentice matters at their various shops, but there were some features which must be handled uniformly at all points and it was up to the instructor to see that these instructions were lived up to.

#### DISCIPLINING APPRENTICES

D. R. Cook, apprentice instructor at Shopton, Iowa, acted as chairman. It was believed to be highly necessary to be strict in the administration of discipline. Those who have tried both the lenient and the strict methods in the nature of experiment have found that by insisting that the boys adhere strictly to the rules of the shops, far better results have been obtained. Certainty of discipline rather than severity is most effective. While it is necessary to be strict in applying demerits for offenses, it is just as necessary to be equally fair with every apprentice in removing demerits when subsequent good behavior and attention to duty justify this. With a large organization such as the Santa Fe it is necessary to keep track of every boy individually by the demerit system, as it is impossible for the supervisor of apprentices at his headquarters to properly check the performance of the large number of apprentices without the use of some such system.

#### SELECTION OF MEN FOR SPECIAL WORK

J. H. Linn, assistant to the supervisor of apprentices, gave a talk at the closing session on the selection of men for special work. He spoke of the rapidity with which the apprentice graduates had been promoted during the past year, and called attention to the importance of carefully selecting the boys for the jobs most suitable for them. The boys, if handled correctly and studied properly, will be found to be especially adapted for one position or another. This should be kept in mind, and when recommendations are asked for appointments, the instructors should be in a position to promptly fill them.

It was pointed out that at no time previously had so many calls been made upon the department for recommendations of young men who could qualify to do certain special work or for executive positions. The policy of the management in filling all vacancies with men in the employ of the company and of giving preference to the graduates has given the apprentice boys a wonderful opportunity for advancement and the instructors an opportunity to prove to the company the value of the work they are doing. The instructors were urged to study each boy carefully and to get so close to him that they may be in a position to know not only the boy's experience, but also his habits and ambitions. When they have learned of a boy's special fitness for any particular class of work they should pass this information on to the supervisor of apprentices and to the master mechanic and mechanical superintendents. The instructors should not wait until

a vacancy occurs, but should find out each boy's special fitness, and after giving him as broad training as possible on the work of his trade should give him opportunities for development along the lines for which he is especially fitted. In selecting these young men three things are to be considered. First, the boy himself; second, his fitness for the particular job in question; and third, his experience and training for such work.

#### SPECIAL APPRENTICES AND SPECIAL COURSE APPRENTICES

In the discussion of this subject the supervisor of apprentices stated that the results formerly secured from the employment of college men as special apprentices had not been very satisfactory, and that formerly these men were given much special work and not sufficient practical work; since these young men are now being kept closely in the shop and required to thoroughly master the work of their trade much better results are being secured. Special apprentices in general were found to be slow in doing the work in the earlier stages of their apprenticeship, this probably being due to the colleges requiring them to do such careful, exact work, regardless of the amount of time required for it. Some of these men had failed to mix well with the other shop men and had been impatient for advancement. Many of them leave the service, some because of greater financial inducements elsewhere, others because of their unwillingness to go through the regular grind, others because of their unfitness for railroad work.

The class of special apprentices in service at the present time is said to be better than at any time previous. They seem brighter, more adaptable to the shop work, and show greater possibility for leadership. This improvement is due partly to greater care in the selection of these young men and partly to the greater amount of practical experience given them. The special course for the last year of their apprenticeship has been giving these men a greater variety of training and fits them better for foremanship. The monthly letters which they have been called upon to write have taught them to be more observant in the shop and have helped materially in developing their executive ability.

This special course is open to certain of the regular apprentices also, and the supervisor of apprentices stated that just now there was a contest on to see which would turn out the better, the college man who served his special apprentice course, including the special course, or the regular journeyman apprentices who are given this course. Each instructor has been called on to report the progress of his special apprentices as well as the special course apprentices, and the reports indicate that these young men are doing particularly well.

#### OTHER DISCUSSIONS

The conference was also addressed by J. W. Gibbons, master painter of the Santa Fe, who gave a talk on the general subject of paint, explaining in some detail the different services required of paint and the effects of different ingredients in the paint. He explained a series of tests that he has been conducting for the past year or two for the Master Car & Locomotive Painters' Association, showing the effect of the weather on different paints.

D. M. Lewis, representative of the Westinghouse Air Brake Company, gave an interesting talk on the care and maintenance of air brakes, and the best methods of teaching this subject.

The convention was a very enthusiastic one, every instructor entering heartily into the various discussions. Although much has been published regarding the success of the apprenticeship system of the Santa Fe, it is not generally known how thoroughly this company has gone into the question of educating and training the young men who are to be its future mechanics. Mr. Thomas' remarkable success

has been largely due to the class of men he has selected as instructors, all of whom are men of the Santa Fe's own making.

## ANALYZING ENGINE FAILURES\*

BY A. PARK

There are so many causes for engine failures that the average railroad man will say it is a case of genuine luck to operate for any length of time without a failure; yet there are many divisions on which a failure is a rare occurrence while on neighboring divisions, with similar types of power, there are all kinds of locomotive trouble.

Locating the real cause of a failure after it has occurred is very often a complicated matter and some of the reasons put forth by the roundhouse forces are as interesting as a dime novel. On the other hand, we find many men who are gifted in locating the exact trouble—as they think—and then will apply such absurd remedies that very often the result is a complete change from one extreme to the other.

It is the ambition of every roundhouse foreman and other mechanical department officer to eliminate all failures possible, and while it is impossible to work out a regular standard plan or organization to meet every requirement of the many different terminals throughout the country, there are certain things in common that should be given attention, the most important being the analyzing of the trouble so that the proper remedies can be applied. After a failure has occurred there is no use making any radical changes or corrections unless to eliminate the primary cause of the failure. The very best of good workmanship will not prevent future trouble unless applied at the proper place. All too frequently the average roundhouse man will only look for the "symptoms" of the failure and will not get down to the exact cause. Hot boxes are one of the worst evils to contend with, for when a journal is reported as running hot everything else is checked except the fact that perhaps there was too much packing in the box. One of the old-time ideas in packing boxes was to put in all the packing the box would hold and then add a little more for good measure, and the adding of the "little more" did the trick, for it prevented the oil from getting through the packing properly.

The question of who should be the proper person to analyze the different engine failures is very hard to settle, for we cannot expect the roundhouse foreman to neglect his other numerous duties to follow up some failure that is liable to require a laboratory test before it is solved. But the cure of engine failures has such a wide bearing on the cost and schedule of train operation that it would seem as if the field were big enough to demand the entire services of a mechanic who could devote his time to analyzing failures. It must be admitted that some failures are traceable to poor workmanship in both the roundhouses and general repair shops, but these cases are so self-evident that they do not require much analyzing. The art of "putting it up" to the other fellow should not be tolerated, for some men do cover up their own shortcomings in this manner, and there are many good foremen who have lost their jobs simply because they were apparently at fault. When a failure occurs, do not discharge the foreman till the failure has been thoroughly analyzed. In one case where crank pins were giving a great deal of trouble by running hot it was thought that the work was not given enough personal attention by the foreman, until it was discovered that the pins were too small for the right amount of bearing surface; while in another case, where the engine truck bearings had been causing trouble by running hot, the blame was placed on the box packer till a thorough investigation showed that the axles were too small. This investigation developed the fact that the box packer was a very conscientious workman who had been giving these particular

bearings a great deal of attention and study, and in fact had been buying extra lubricating material out of his own pocket so as to overcome the hot bearings, but he could not stop them, and it was found the real trouble was in construction.

On the other hand, there are many failures charged up against the mechanical department for which they are in no way to blame. We do not expect as much from an engine that has made a big mileage as we do from a new engine, and yet the transportation department will make no variation in the tonnage, with the result of a breakdown. Some roads claim that it pays to give an engine a general overhauling twice a year rather than to give one overhauling and maintain the running repairs in the roundhouse. From an economical standpoint, it will cost a trifle more to give the two overhauls, but the costly engine failures are not as liable to occur and it is also possible to reduce the roundhouse repairs. Then, again, it gives the engine a higher average efficiency rating. In making either an efficiency rating chart or a maintenance cost chart, it is very noticeable how quickly the efficiency decreases after three months of service and how the maintenance cost increases after the same length of service.

Very often, in analyzing failures, economical features are developed, for when there is a failure in material, it is usually a fact that if a higher grade of material had been used the failure would not have occurred. Economy should be practised, but not to the detriment of service. Welded safe end tubes are all right unless too many safe ends are used. There should be some definite number of safe ends that can be applied, and after the limit has been reached the old tube should be scrapped. One road has adopted the very wise plan of using tubes from the longest boilers in short boilers after they have had a certain number of safe ends applied.

Poor design is one of the worst features the roundhouse man has to contend with. When a part requires a great amount of attention, and it is very hard or almost impossible to get at it with the regular tools, it stands to reason the part will not get the attention that should be given it. This idea applies to places where nuts or bolts work loose quite frequently, and it is impossible to get at them with wrenches; it is then necessary to do all tightening up with a set. The practical mechanic is confronted with some difficult propositions, and when he does come in contact with any of these impossible things the matter should be taken up with the "analyzer" at once so that corrections can be made before a failure occurs and is charged to lack of attention. Weakness of equipment should also come under this head, for after an engine has been in service some time and it is noted that some important part is not going to stand up under hard usage, immediate steps should be taken to have it reinforced.

We frequently hear a roundhouse foreman, in excusing some failure that has happened, claim that it was a "man" failure, which places the blame on the engineman. This is a poor excuse, for while it is admitted that there are some failures which are caused by the engineman losing his head, the main reason, which should be developed by thoroughly analyzing the trouble, generally shows some mechanical defect. A cause of a great amount of trouble is water in the cylinders and the breaking of front cylinder heads. Every time this failure occurs the roundhouse foreman will blame the engineman—which is right to some extent—and the engineman will of course lay the blame on poor cylinder cocks. These failures can be prevented to a much greater extent if everything is made as simple and plain as possible so that it will be "fool proof." It is all very well to tell how certain breakdowns should have been handled after they have happened, but at the time when everyone is in a hurry the right move is not always made. The best method to cover these conditions is to determine the cause and then apply a proper remedy so as to prevent a recurrence. One of the most annoying failures the roundhouse has to contend with is the "burning up" of an air pump so that the engine has to give

\*Entered in the Engine Terminal Competition.



up the train before starting out. This trouble can be prevented to a great extent by the engine man.

Failures from lubrication will always occur till the engine man and roundhouse force are thoroughly educated as to the correct methods and proper time of applying sufficient lubrication. To investigate a failure of this nature, one would be led to believe from the standpoint of the engine man that he never had sufficient oil, while the roundhouse foreman will claim the supply was "enough to take a bath in." We all know the value of a drop of oil at the right time, and if a good failure "analyzer" can investigate both sides of the question with the view of preventing a possible engine failure, it is almost a foregone conclusion that a just decision will be rendered.

One great trouble with the roundhouse force is that if they enjoy a short period of having no failures they consider their work so good that they have the situation well in hand and will let up a little on their attention to the small items. In the meantime, so many small things are getting the upper hand of them that all at once everything goes all to pieces and the cry goes forth that an "epidemic of failures" is occurring and immediately everyone becomes overworked. There is much discussion of whether or not failures can be prevented "before they occur" by close attention and good work and, while the question has never been definitely settled, it is a fact that there is a decided decrease in the total number of failures if proper steps are taken to prevent them. A good example of this idea was the experience of a road where the mechanical department began to apply new fireboxes to a certain class of engines before the engines had been in service for any great length of time. The officers of this road were advised by their boiler department when to expect the fireboxes to give out and rather than suffer several costly failures it was decided to take the work in hand before anything happened. The result was less trouble in the roundhouse, no failures, and engines that were always in good condition. This same type of engine was used on a neighboring road, but no attention was given to the renewal of the fireboxes, and the result was not only several failures, but just at the time when the road needed the power the most the engines were continually tied up for boiler work.

One of the many strong arguments in favor of a regular man for the specific duty of analyzing engine failures is the unprejudiced manner in which he can investigate the work and the fair decisions he can render, for he is not trying to cover up any of his own shortcomings and will place the blame on the guilty party. A roundhouse foreman who is at fault will tend to show up certain things in a strong light so as to clear himself of any responsibility thereby covering up to some extent the real cause. Other officers who conduct such an investigation must put the blame on someone and they are liable to enlarge small points so that the apparently guilty man will have to accept the blame. One of the evils of this nature which might be mentioned is failures from engines not steaming, cause given as "poor coal." While it is admitted that perhaps the coal is not all that is desired, an impartial investigation would develop that the steaming qualities of the engine were not the best, and if the engine had been in proper shape, it might have made the trip without a failure. Still further investigation would sometimes develop the fact that in addition to poor coal and a poor steaming engine, the real cause of the failure was due to a fireman who did not understand his business very well. Comparatively good results can be obtained by a fireman who is familiar with the best methods of firing and in a case of this kind the blame should be distributed between all three of the causes instead of placing it all against "poor coal."

One reason why some failures are not thoroughly analyzed is because they pass through too many hands before any definite action is taken. A large amount of unnecessary correspondence is caused by some high officer starting an investi-

gation and every other officer under him writing letters on the same subject. The roundhouse foreman writes a letter to his superior officer, and the same routine is carried out till at last the original report reaches headquarters and the meaning has been changed so many times that it does not resemble the original report at all. How much better it would be for some one man to handle all the investigations, and if anyone on the road wanted an explanation there would be one man who had not only made a personal investigation, but had also seen the result of the failure and knew every phase of the case.

One case of misapplied discipline will do a great deal of harm. It is necessary to apply discipline in some cases so as to keep down to the minimum the failures that will happen if the workmen are allowed to do poor work, but if a workman can get away with a poor job which in turn causes a failure, the foreman in charge should stand some of the blame. By having an official investigator the foreman will have more time to devote personal attention to the quality of work done by his workmen.

If an engine man brings his train to the terminal after the breaking of a part the part that fails should be investigated just as thoroughly as if a long detention had occurred. Some engine men will make up the time lost in correcting a slight breakdown so as to arrive at the terminal on time, and the breakdown will not be reported as a "failure." Then, again, the light in which failures are held on some roads tends to cover up the small failures that in some cases serve as a warning of possible greater failures. A failure is the warning that something should be given immediate attention. If a small part on some particular engine gives out, it is probable that all the engines of that class will develop the same weakness and the time to prevent trouble is before they give out.

Eternal vigilance is the key to successful operation, but if the eternal vigilance is misdirected by a poor or wrong analysis, which is very often the case, the result is a waste of money and time and the cause of much worry on the part of the operating officers. Surface indications are only "symptoms" and corrections should not be based on hasty conclusions made on surface defects, but there should be a thorough analysis so as to reach the root of the trouble. Modern roundhouses will not solve the failure problem unless they are used as a place to develop the "why" of engine troubles.

### THOMAS-LANGLEY GAGE COCK

Several years ago T. J. Langley, assistant superintendent motive power and E. Thomas, master mechanic of the Oregon-Washington Railroad & Navigation Company, designed a self-grinding gage cock which, after several modifications made as the result of service tests, has finally been developed to the form shown in the illustration. The

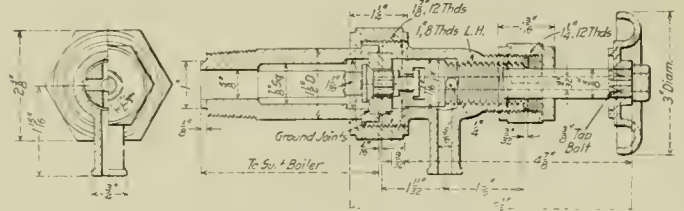

A Self-Grinding Gage Cock

purpose of the device is to provide a free opening to test the water level, a tight closing to prevent leakage,—easy operation, and a means whereby the valve can be ground free of obstruction without the use of tools and while the boiler is under pressure.

If leaking develops a slight twist of the handle to the

left and right is all that is usually required to quickly grind the valve free, so that it will close tightly. In aggravated cases it is sometimes necessary to twist the handle back and forth several times. While this is being done the pressure in the boiler holds the valve tightly against the seat. When it is desired to open the valve the handle is turned in the usual way, except that the valve merely turns on the seat, and does not open until one full turn has been completed, when the stem commences to force the valve proper off its seat. In ordinary practice, however, the engineer in closing the valve will only turn the handle until the valve seats, so that it may be opened with the same amount of movement as an ordinary gage cock. In case a little scale gets under the seat, by turning the valve to the right and left quickly, it will be displaced or ground off.

The gage cock is made so it can be cleaned out under pressure by using a hollow stem. This construction is especially adapted for use in bad water districts.

Gage cocks of this type are said never to have given any trouble from leaking. The only work required has been to remove and clean them according to law. Should any work be required the cock can be placed at any angle without undue turning of the nipple in the boiler.

## THE OPERATION OF A LARGE ENGINE TERMINAL\*

BY T. H. ADAMS

Assistant Foreman, Norfolk & Western, West Roanoke, Va.

The principal point in getting results from a large engine terminal is that the man in charge have the complete co-operation of his subordinates and the full confidence of his superiors. He should work in perfect harmony with the road foreman of engines and the division despatchers, and without this I believe his most sincere efforts would be without avail. At West Roanoke this practice is followed out in connection with a well organized working system. I personally follow the working of the system in every detail, and I believe that the greatest success is secured by the man in charge being "on the job" at all times and all the work should be followed up closely.

There are turned at this terminal on an average 140 locomotives per day, of which about 50 are Mallet compound engines. We have a roundhouse of 40 stalls, and our force is divided up into six departments consisting of the passenger engine repair force, freight engine repair force, machine shop, boiler force, hostlers' gang and laborer gang, each unit having its own foreman. The men in each department are well organized and instructed in their line of work and special duties are assigned to every one.

When an engine arrives on the relieving track a tool inspector checks all the tools and makes out a report on a form provided for this purpose, noting any shortage, which is at once investigated and taken up with the man responsible. The hostler takes charge of the engine and examines the boiler wash card to see if the locomotive is due for washing, examines the firebox for leaks, and tests injectors, gage cocks and check valve for defects. The engine is then given a spot test under steam pressure to find any steam defects that may exist, a report of which is made and attached to the engineman's inspection report.

The engine is then taken to the ashpit, where the fire is cleaned or drawn; coal is supplied and the engine moves on to the roundhouse. Great care is used in selecting the coal for the engines on passenger and important freight runs so as to reduce steam failures on such runs to a minimum. This is done by an arrangement of our coal chute, which is provided with three compartments, one for passenger engines, which get the best grade of coal, one with run-of-mine

coal for hand-fired freight engines, and one with slack coal for stoker-fired engines.

On the arrival of an engine at the roundhouse it is carefully inspected by a competent inspector, who makes a report which is attached to the engineman's report; the work is then copied off by a clerk and distributed to the various workmen, who, after completing the work under the personal supervision of their immediate foreman, sign for it on the work report, which is in turn checked by the foreman in charge and marked O. K. before the engine leaves the roundhouse.

The engines are then taken out of the house and inspected by an outgoing inspector and given a spot test for steam leaks before being put on the train. The man making this inspection reports to the foreman any serious defects he finds and he examines the report to see if the incoming inspector reported them, investigating each case to see if the workmen are doing their work properly. In this way we keep all the men "on edge," and to this we attribute our good record with the government inspectors, having had only two engines withdrawn from service at this point since the Federal law has been in effect.

We have had a record system in use at this point for about one year, to which we attribute a 40 per cent reduction in engine failures. It is carried out by suspending any workman whose carelessness or improper workmanship results in an engine failure. A notice of all suspensions is posted on a bulletin board, and we have not given a suspension that did not result in making a better and more careful workman out of the man receiving it, and the moral effect among the other workmen is decidedly noticeable.

I personally follow up the condition of the power and inspect each engine thoroughly once or twice a month, rendering a monthly report to the superintendent of motive power as to locomotives' condition. We maintain a general average of about 40,000 miles between general overhauls of the engines. This is kept up by giving the engines light repairs in the roundhouse. We have found that it pays better to do every job the day it is reported and found necessary than to postpone it to some more convenient time, and by this practice we have gained the confidence and co-operation of the road foreman and engine crews.

After the engines are ordered by the transportation department they are taken in charge by hostlers, who get the fire in good condition, inspect the engine carefully, check all tools, coal the engine, if necessary, fill tank with water, fill lubricators and place the engine on the train. The engine crews report 15 min. before leaving time, which is ample to inspect the engine and oil the machinery. By this arrangement we have greatly reduced delays to engines after they are called.

We follow up the expense problem very closely. Foremen check all orders on the storehouse for material, and the storehouse in turn furnishes each foreman a daily itemized account of all material used by his department, showing the cost and giving a comparison with the day previous and the same day in the month previous; in this way we keep the material expenses before the foreman at all times.

The roundhouse and premises are kept in a neat and clean condition; this is practiced so thoroughly at this point that I believe every person connected with our force takes a special interest in it.

One most important consideration in reducing terminal delays or the turning time of locomotives is to avoid congestion on the ashpits or the tracks between them and the roundhouse, for when engines are kept moving on these tracks the entire force of the engine terminal is busy.

**USE OF FIRE BRICK.**—To reduce the maintenance cost of furnace lining in stoker-fired, forced-draft boilers, a high-grade fire brick is used up to the fire line. A bauxite brick is commonly employed for this purpose.—*Power.*

\*Entered in the Engine Terminal Competition.

# A LOCOMOTIVE INSPECTION SYSTEM

Designed to Produce Thorough Inspection and Facilitate Compliance with the Federal Rules

BY N. M. BARKER

Master Mechanic, Copper Range Railroad, Houghton, Mich.

Efficient inspection is recognized as an important factor in the economical operation of motive power. In making proper repairs to the defects disclosed by such inspection, the possibilities of many costly delays, failures and even serious accidents are very greatly lessened, and either a longer period between shoppings or an equivalent reduction in the cost of locomotive mileage is insured.

To secure such inspection it is obvious that the requirements involved are:

1. A basis upon which inspections shall be made.
2. Competent inspectors.
3. A system that shall anticipate required inspections.
4. A record of inspections that have been made.

Since the Interstate Commerce Commission has been given authority over the entire locomotive, and has, with the assist-

vary for the different appurtenances of the locomotive, the matter becomes somewhat complicated.

At the point where this system has been in effect since January 1, 1916, we are maintaining only 21 locomotives, and as the inspectors, therefore, have other duties beside inspection, it was found advisable to classify them under the name of the department to which they are attached. There are four inspectors; one boiler inspector, two back shop inspectors and one enginehouse inspector. Each inspector is provided with a desk, stationery, and a copy of "Rules and Instructions for the Inspection and Testing of Locomotives and Tenders."

A copy of special instructions issued by the master mechanic, which cover, in a condensed form, the time for inspections and methods to be employed in making the inspections

LOCOMOTIVE NO. 52																		THE YEARS THIS YEAR			DATE			
MONTHLY															QUARTERLY			ANNUAL						
INSPECTION TO BE MADE	10	11	12	13	14	15	16	17	18	19	20	21	22	23	24	25	26	27	28	29	30	31	DATE	INSPECTOR WHO MADE IN COLLECTING COVERING INSPECTION MADE BY HIM AND SIGN FOR SAME IN THIS COLUMN.
BOILER	WATER TANK	STEAM	LINKS	TRUCKS	TRUCKS	TRUCKS	TRUCKS	TRUCKS	TRUCKS	TRUCKS	TRUCKS	TRUCKS	TRUCKS	TRUCKS	TRUCKS	TRUCKS	TRUCKS	TRUCKS	TRUCKS	TRUCKS	TRUCKS	TRUCKS	TRUCKS	
ANNUAL	a	a	a	5%	a	a	Y	LAST ANNUAL INSPECTION AND TESTS JAN 9, 1916	a	a	a	a	a	a	a	a	a	a	a	a	a	a	JAN 10, 1916	O A Brown
	a	a	a	5%	a	a	Y																FEB 12, "	O A Brown
	a	a	a	5/1	a	a	Y																MAR 11, "	O A Brown
	a	a	a	1%	a	a	X																APR 9, "	O A Brown
	a	a	a	1/2	a	a	X																MAY 10, "	O A Brown
	a	a	a	2%	a	a	X																JUNE 11, "	O A Brown
	a	a	a	3%	a	a	X																JULY 14, "	O A Brown
	a	a	a	4%	a	a	Y																AUG 12, "	O A Brown
	a	a	a	1/2	a	a	X																SEP 9, "	O A Brown
	a	a	a	1/1	a	a	Y																OCT 10, "	O A Brown
	a	a	a	2%	a	a	Y																NOV 9, "	O A Brown
	a	a	a	3%	a	a	X																DEC 11, "	O A Brown
	a	a	a	4%	a	a	X																JAN 1917	O A Brown
	a	a	a	1/4	a	a	X																FEB "	O A Brown
	a	a	a	1/4	a	a	X																MAR 24, "	O A Brown

Fig. 1—Page of Boiler Inspector's Record Book

ance of railway officers, formulated a set of rules and instructions governing these inspections, it will be granted that these rules and instructions shall be the accepted basis upon which the inspections shall be made.

The qualifications of a competent inspector have been quite thoroughly discussed in previous issues of this publication. It is the purpose of this article to describe a system of anticipating required inspections and recording them in such a manner that it will be evident on what date they will be again required. A brief study of the rules and instructions referred to above, reveals the fact that there are certain things to be done at stated intervals of time, but as these intervals

for which he is responsible, is framed and screwed to the wall just above each inspector's desk. These special instructions were issued with the inception of the new rules, in order that each inspector should acquire a knowledge of just what part of the work was assigned to him, and also to enable him to become thoroughly familiar with his duties in as short a time as possible. They have also proved valuable for reference and will serve as a guide for new inspectors. The accompanying tables show the form of these instructions as issued to the different inspectors. The numbers to the left of the items under the heading, "Time of Inspections and Tests," refers to the numbered descriptions under the heading,



cocks shall be removed and cocks thoroughly cleaned of scale and sediment.

11. Steam Leaks—Every month.

Method: All steam leaks shall be repaired.

12. Staybolts and Crown Stays—Every month.

Method: Staybolts shall be tested by hammer after the water is drained from the boiler.

13. Flues and Firebox Sheets—Every month.

Method: Condition of all flues and firebox sheets shall be noted and all leaks and cracks repaired.

14. Arch Tubes and Water Bar Tubes—Every month.

Method: Condition shall be noted and tubes shall be kept free from scale and sediment.

15. Fusible Plug—None used.

16. Hydrostatic Test—Every year.

Method: Boiler shall be subjected to hydrostatic pressure 25 per cent above working steam pressure.

17. Removal of Caps from Flexible Staybolts—Every 18 months.

Method: Caps shall be removed and bolts thoroughly inspected.

18. Removal of Flues—Every three years.

Method: All flues shall be removed and thoroughly cleaned and the weight noted. Interior of boiler shall be thoroughly cleaned and all scale and sediment removed. The entire interior of the boiler shall then be examined for cracks, pitting, grooving or indications of overheating, and for damage where mud has collected or heavy scale formed. The edges of plates, all laps, seams and points where cracks and defects are likely to develop, shall be given especially minute examination. All braces and

Methods of Inspections and Tests

1. Steam Gage Test—Every three months.

Method: Steam gages shall be compared with an accurate test gage or dead weight tester, and gages found inaccurate shall be corrected before being put into service.

2. Safety Valve Test—Every three months.

Method: Safety valves shall be set to pop at pressures not exceeding six pounds above working steam pressure. When setting safety valves, two steam gages shall be used, one of which must be so located that it will be in full view of the person engaged in setting such valves; and if the pressure indicated by the gage varies more than three pounds they shall be removed from the boiler, tested and corrected before the safety valves are set. Gages shall in all cases be tested immediately before the safety valves are set or any change made in the setting. When setting safety valves the water level in the boiler shall not be above the highest gage cock.

3. Injectors—Every month (also before each trip).

Method: Injectors shall be in such condition that they will deliver water to the boiler without excessive overflow and all boiler checks, delivery pipes, feed water pipes, tank hose and tank valves shall be in good condition, free from leaks and from foreign substances that will obstruct the flow of water.

4. Steam Leak Inspection—Every month.

Method—All valves, fittings and other appurtenances of boiler, located in the cab, shall be inspected each month, and if leaking or otherwise not in safe or suitable condition for service, shall be repaired before engine is again put in service.

5. Brake and Signal Equipment.

A.—Compressor Test—Every three months.

Method: All compressors shall be tested for capacity by orifice test. The diameter of orifice, speed of compressor and the air pressure to be maintained is to be as follows:

Size of compressor and make	Single strokes per minute	Diameter of orifice	Air pressure maintained
Westinghouse 9½ in.	120	11/64 in.	60 lb.

Note: Air pumps overhauled and kept on rack shall be considered as tested on date applied to locomotives

B.—Main Reservoir Test—Every 12 months.

Method: Subjected to hydrostatic pressure not less than 25 per cent above the maximum allowed air pressure. The hydrostatic pressure shall be 150 lb. per square inch.

C.—Air Gage Test—Every three months.

Method: Air gages shall be compared with dead weight tester and gages found incorrect shall be repaired before they are returned to service.

D.—Other Locomotive Brake Equipment—Every six months.

Method: All equipment shall be cleaned and lubricated and the date shall be stenciled on metal tag as per rule No. 11, Rules and Instructions for Inspection and Testing of Steam Locomotives and Tenders.

1. Distributing or control valves.
2. Triple valves.
3. Reducing valves.
4. Straight air double check valves.
5. Dirt collectors.
6. Brake cylinders.

E.—Piston Travel Test—Every month.

Method: The maximum piston travel when the locomotive is standing shall be as follows:

Driving wheel brake.....	6 in.
Engine truck brake.....	8 in.
Tender brake.....	9 in.

F.—Foundation Brake Gear Inspection—Every month.

Method: All parts of brake gear shall be in safe and suitable condition as per Rule 13, and no part shall be less than 2½ in. above the rails.

G.—Leakage Test—Every month.

1. Main reservoir and relating piping leakage shall not exceed 9 lb. in 3 min.
2. Brake pipe leakage shall not exceed 5 lb. per min.
3. Brake Cylinder Leakage: With a full service application from maximum brake pipe pressure, and with communication to the brake cylinders closed, the brakes on locomotive and tender shall remain applied not less than 5 minutes.

H.—Train Signal System Test—Every month.

Shall be tested and known to be in safe and suitable condition.

SPECIAL INSTRUCTIONS FOR ENGINEHOUSE INSPECTORS

1. Inspections will be made upon the same day that the engine is held in for washout. (See locomotive boiler washout sheet.)

2. Results of inspections will be recorded in the book provided, immediately after inspection.

3. Enginehouse inspectors must be conversant with "Rules and Instructions for the Inspection of Locomotives and Tenders," particularly rules No. 22 to No. 58 inclusive. A copy of these rules will be provided each inspector and if the inspector is in doubt as to the meaning, explanation will be made by the master mechanic.

4. Enginehouse inspectors will be required to make such inspections, tests and repairs as are required to answer questions No. 6 to No. 9 inclusive on the monthly report and questions No. 28 to No. 32 inclusive on the annual report. The most important requirements are as follows:

Time of Inspections and Tests

Monthly	Each 3 Months	Each 6 Months	Annually
6A. Draw gear.	6B. Draw gear, and all monthly inspections.	7. Driving gear.	8. Running gear.
9. Tender.	Each 3 Months	Each 6 Months	Annually

Methods of Inspections and Tests

6A. Draw Gear and Draft Gear—Every month.  
All parts shall be inspected and shall not be returned to service unless in safe and suitable condition for service.

LOCOMOTIVE No. 52		THREE MONTHS MONTHLY					ENGINE HOUSE	
INSPECTIONS TO BE MADE	REFER TO WASH SHEET	6A	7	8	9	6B	DATE.	INSPECTOR WILL SIGN IN COLUMN, OTHER INSPECTIONS MADE BY HIM AND SIGN FOR SAME IN THIS COLUMN.
		DRIVING GEAR	TRIP GEAR	TENDER	DRAFT GEAR			
ANNUAL		0	0	0	0	0	JAN 10, 1916	A Smith
		0	0	0	0	0	FEB 12, "	A Smith
		0	0	0	0	0	MAR 11, "	A Smith
THREE MONTHS		0	0	0	0	0	APR 9, "	A Smith
		0	0	0	0	0	MAY 10, "	A Smith
		0	0	0	0	0	JUNE 11, "	A Smith
THREE MONTHS		0	0	0	0	0	JULY 14, "	A Smith
		0	0	0	0	0	AUG 12, "	A Smith
		0	0	0	0	0	SEP 9, "	A Smith
THREE MONTHS		0	0	0	0	0	OCT 10, "	A Smith
		0	0	0	0	0	NOV 9, "	A Smith
		0	0	0	0	0	DEC 11, "	A Smith
	OUT OF SERVICE ACCT. REPAIRS						JAN 1917	A Smith
	OUT OF SERVICE						FEB - "	A Smith
ANNUAL		0	0	0	0	0	MAR 24, "	A Smith

Fig. 3—Page of Enginehouse Inspector's Book

stays shall be taut, pins secured in place, and each shall be in condition to support its proportion of the load.

19. Removal of Lagging—Every five years.

Method: Jacket and lagging shall be removed and exterior of boiler thoroughly inspected.

SPECIAL INSTRUCTIONS FOR BACK SHOP INSPECTORS

1. Inspections will be made upon the same day that the engine is held in for washout. (See locomotive boiler washout sheet.)

2. Results of inspections will be recorded in the book provided, immediately after inspection.

3. Back shop inspectors must be conversant with "Rules and Instructions for the Inspection and Testing of Locomotives and Tenders," particularly rules No. 6 to No. 21 inclusive. A copy of these rules will be provided each inspector, and if the inspector is in doubt as to their meaning, explanation will be made by the master mechanic.

4. Back shop inspectors will be required to make such inspections, tests and repairs as are required to answer questions No. 1 to No. 5 inclusive on monthly report and questions No. 22 to No. 27 on annual report. The most important requirements are as follows:

Time of Inspections and Tests

Monthly	Each 3 Months	Each 6 Months	Annually
3. Injectors.	1. Steam gage.	5I. Other locomotive brake equipment and all monthly and tri-monthly inspections and tests.	5B. Main reservoir and all monthly, tri-monthly and semi-annual inspections and tests.
4. Steam leaks.	2. Safety valve.		
5E. Piston travel.	5A. Compressor.		
5F. Foundation brake.	5C. Air gage and all monthly inspections and tests.		
5G. Leakage test.			
5H. Train signal.			

6B. Draw Gear Between Locomotive and Tender; Inspection—Every three months.

Method: Pins and drawbar shall be removed and carefully examined and not returned if not found safe and suitable for service.

7. Driving Gear Inspection—Every month.

A.—Crossheads shall not have more than 1/4 in. vertical nor 5/16 in. lateral play between the guides.

B.—Guides shall be securely fastened; all nuts shall be kept tightened.

C.—Pistons and piston rods shall be examined for cracks and defects each time they are removed.

D.—Rods—Side and Main.—All cracked or defective side rods shall be removed from service. Lateral motion of rods on crank pins shall not exceed 1/4 in.

On Road Locomotives: Bore of main rod bearings shall not exceed diameter of pin more than 1/8 in. Bore of side rod bearings shall not exceed pin diameter more than 5/32 in. on main pin, nor more than 3/16 in. on other pins.

On Yard Locomotives: Bore of main rod bearing shall not exceed diameter of pin more than 1/8 in. at the front end, nor more than 5/32 in. at the back end. Bore of side rod bearings shall not exceed diameter of pin more than 3/16 in.

8. Running Gear Inspections—Every month.

A.—Driving boxes shall not have more than one shim between box and bearing.

B.—Lateral motion shall not exceed the following limits:

Engine truck wheels (swing centers).....	1 in.
Engine truck wheels (rigid centers).....	1 1/2 in.
Trailing truck wheels .....	1 in.
Driving wheels .....	3/4 in.

C.—Pilots and Plows:

Minimum clearance above rails.....	3 in.
Maximum clearance above rails.....	6 in.

D.—Spring Rigging:

Springs or rigging with following defects shall be repaired or renewed: One long leaf or two or more short leaves broken; leaves working in band; broken coil springs; broken driving box saddle, equalizer, hanger, bolt or pin.

E.—Trucks: Male center plate shall extend into female center plate not less than 3/4 in.

F.—Wheels: See rules and use limit gage.

9. Tender Inspection—Every month.

A.—The difference between the height of the deck on the tender and the deck of the locomotive shall not exceed 1 1/2 in.

B.—Width of gangway between locomotive and tender while standing on straight track shall not be less than 16 in.

C.—Interior of tanks shall be inspected each month.

D.—Trucks: Male center plate shall extend into female center plate not less than 3/4 in.

### REMOVING AIR POCKETS FROM RESERVOIRS

BY W. H. HAUSER

Mechanical Engineer, Chicago & Eastern Illinois, Danville, Ill.

Paragraph 8 of the Rules and Instructions for the Inspection and Testing of Locomotive Boilers, as approved by the Interstate Commerce Commission, October 11, 1915, requires that main air reservoirs shall be subjected to hydrostatic

axes horizontal, which have the air pipes tapped into the center of the heads of the reservoirs. There is an outlet at the bottom for drainage, but there is no outlet at the top by which the air can escape when filling the reservoir for the hydrostatic test. A hole could be drilled and a plug inserted to allow the removal of this pocketed air, but if this is done it adds another opening for air leaks and places the plug in a very inconvenient position, especially if it becomes necessary to apply one on the road through the plug blowing out. In the method shown in the sketch a copper tube is inserted in the reservoir. This tube has a notched edge by which the air is all blown out and water allowed to fill the entire reservoir. This is very simple, and the apparatus can be bought at a nominal cost.

### GETTING RESULTS FROM A BIG ENGINE TERMINAL\*

BY GEORGE COOK

Roundhouse Foreman, Northern Pacific, Ellensburg, Wash.

Efficiency in enginehouse management is appraised by results. By results we mean a minimum number of engine failures, economy and lack of friction with the transportation department and with employees under the enginehouse foreman. This is obtained through system. System applied to enginehouse management is governed by conditions at the place considered, and includes the method of handling the engines from the incoming switch to the outgoing switch, the consumption of material, the condition of the shop machinery and tools, the treatment of mechanics and laborers, and the condition of buildings and grounds. A system or regular order of procedure should be applied to every act about an engine terminal.

At a point where engines are needed as soon as they are available there should be as little delay as possible between the time they are placed on the incoming track and the time they are put in the house. If conditions will permit this will include supplying them with fuel, sand, water and having grates and ashpans cleaned.

Book records should be kept of all inspection and other work performed. Bearings and packing should all be examined at the end of each trip or day's work, not by putting a hand on the hub of the wheel or the top of the box, but by dropping the cellar and making certain that the packing is properly lubricated and against the journal. Tank and trailer oil box lids should be raised and the packing hook used to reach in and feel if the packing is properly distributed from dust guard to collar. All standard practices should be complied with to the letter. Power is most efficient when each part is maintained in a serviceable condition, and the fact that a stitch in time saves nine and often an engine failure, should never be lost sight of by a foreman. If a certain class of power on any district is giving trouble, each foreman should make an effort to be the first to locate and eliminate the cause. A clean engine is more easily inspected than a dirty one, the working parts last longer. Furthermore the public appreciates traveling on a road which has its locomotives looking bright and clean.

A shop machine or tool in good serviceable condition is a revenue earner; one in poor and unsafe condition is a liability. Much money and energy is wasted in enginehouses through poor tool equipment.

Specialize the work as far as conditions will permit, but have a substitute for every position. Promote the laborers when possible, and a better class of men can be kept in enginehouses. This can be arranged by advancing them to fireman, or having an agreement with the car foreman to draw his laborers from the enginehouse force.

\*Entered in the Enginehouse Competition.

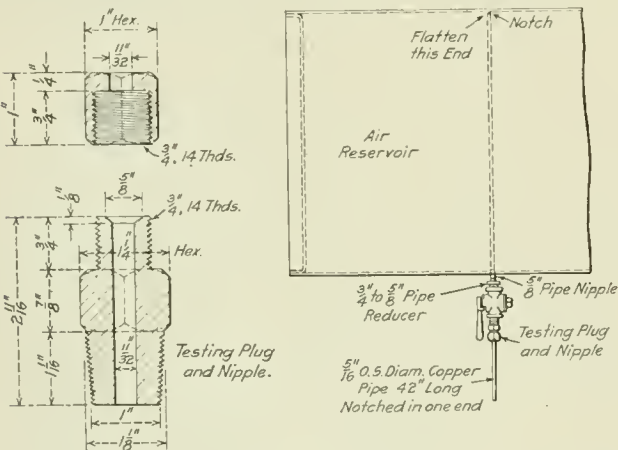

Method of Removing Pocketed Air for a Reservoir

pressure not less than 25 per cent above the maximum allowed air pressure, before being put into service and at least once each 12 months thereafter.

There are in service numerous air reservoirs with their

# New Devices

## INDUCTION MOTOR FOR TURNTABLES AND TRANSFER TABLES

A line of slip ring induction motors for severe intermittent service at varying speeds has been developed by the Westinghouse Electric & Manufacturing Company, East Pittsburgh, Pa. These motors are especially designed for use on cranes, draw bridges, roller lift bridges, railway turntables and

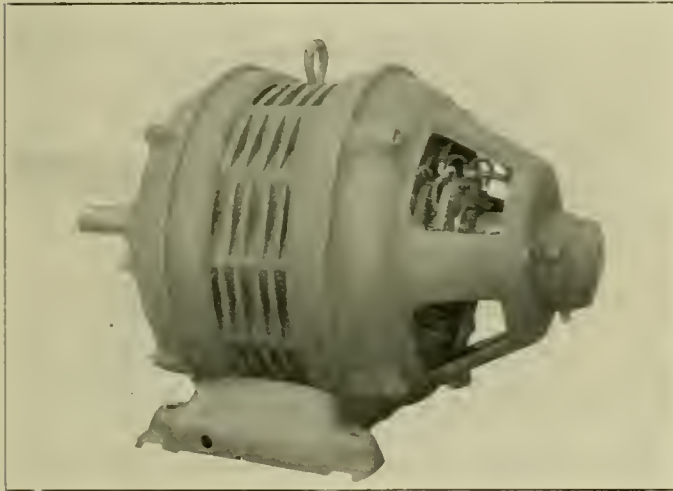

Ten Horsepower Slip Ring Induction Motor with Laminated Frame

transfer tables, and are furnished in sizes from 1½ hp. to 200 hp. They are designed for operation on two or three phase circuits of 25 or 60 cycles frequency at voltages of 220 or 440.

The frames of the larger sizes are made of rolled open-

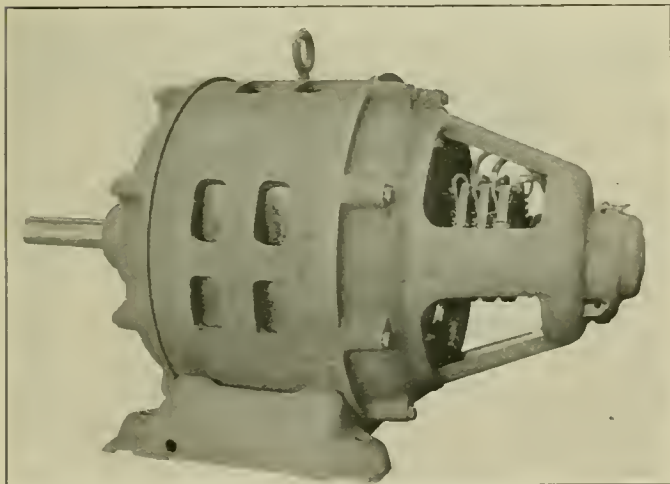

A 75-hp. Motor with Rolled Steel Frame

hearth steel, one of the illustrations showing a 75-hp. motor with this type of frame. On the smaller sizes the frames are made of steel laminations which are riveted together between forged steel end shields. The brackets are of cast

iron with reinforcing ribs to insure perfect alinement of the bearings. The bearings are self-oiling of the oil-ring type and are of large size. The steel brush holders are supported by the brackets from which they are insulated and the brackets are open to permit the brushes to be easily inspected and renewed.

The rotor is small in diameter which reduces the fly-wheel effect to a minimum. This feature together with the perfect balance and secure attachment of the winding makes these motors especially suitable for frequent starting, stopping and reversing. The shaft can be removed from the rotor without disturbing the winding, the construction being such that in case of accident repairs can be made quickly. The weight and over-all dimensions have been kept to the minimum consistent with the strength required.

## BEYER BAROMETRIC CONDENSER

The Ingersoll-Rand Company, New York, is now furnishing complete steam condensing plants for all service conditions. This equipment includes the Beyer barometric condenser, for which the company has secured the patent rights.

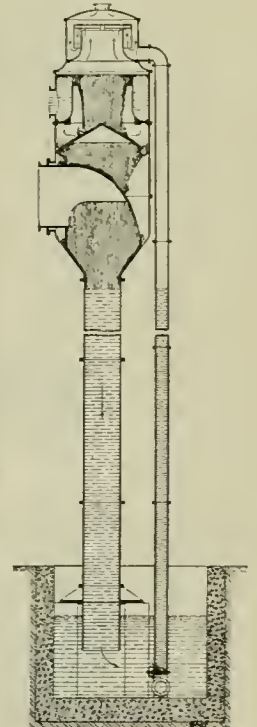
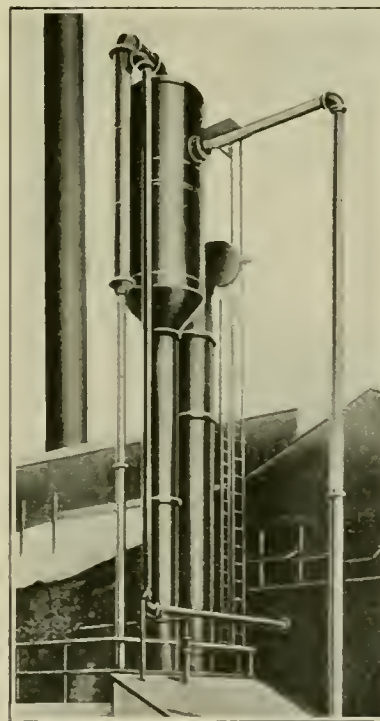

Installation and Section of the Beyer Barometric Condenser

This condenser is of the counter-current type, in which air and cooling water flow in opposite directions. The steam inlet is at the bottom of the condensing vessel, the water inlet above and the air removal opening at the top. The sheets of cooling water, overflowing the pool at the inlet point, meet the entering steam. The two are brought into intimate contact by conical baffle plates assisting the water

to absorb to its full capacity the latent heat of the steam. The non-condensable air liberated in the condensing action rises through the falling water to the removal point at the top, being cooled to practically the temperature of the incoming water. Ample opportunity is given for the removal of the air content of the water before it mixes with the steam. This not only facilitates the mixing process, but permits the removal of air and vapor at a comparatively low temperature, which is an advantage, as the reduced volume saves in vacuum pumpage horsepower.

The steam inlet is of large diameter to secure low velocity and is hooded in such a way as to discharge the steam into the center of the condensing vessel. The air removal opening is protected by a self-draining baffle and trap, which it is claimed positively prevents water being carried over into the vacuum pump. The hot waste water is discharged through the self-draining tail pipe. This pipe straddles the hot well and supports the condenser.

### HYDRAULIC FORCING PRESS

The hydraulic press shown in the engraving is a new design of inverted forcing press recently brought out by the Hydraulic Press Mfg. Company, Mount Gilead, Ohio. This is a double purpose press, being intended for two distinct forcing operations. It is constructed in two parts, the

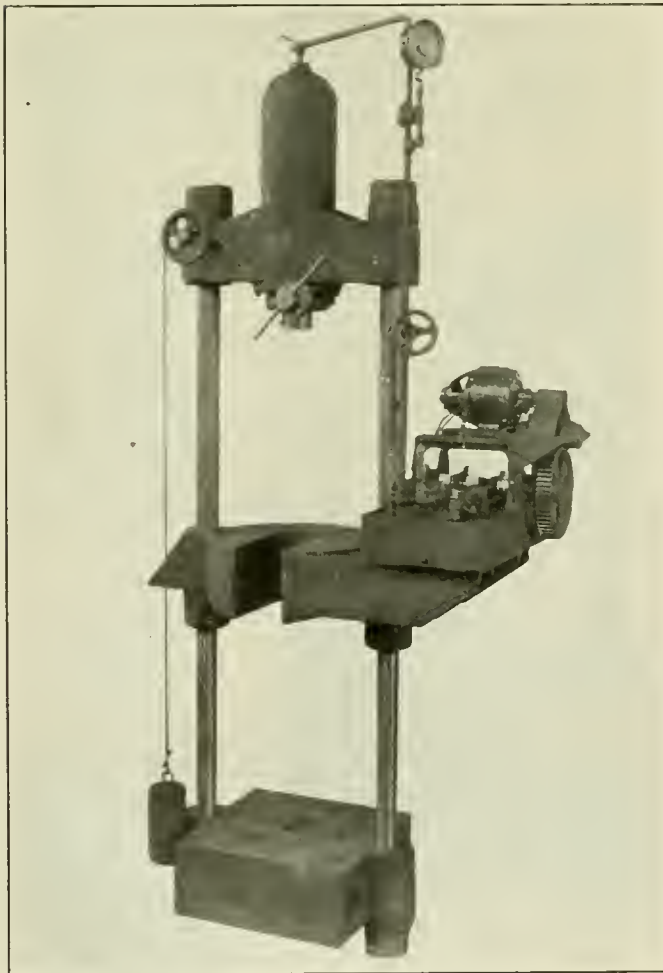

Inverted Forcing Press with Motor-Driven Pump

upper part having a maximum pressure capacity of 100 tons and the lower part 50 tons.

The press was primarily designed for use in applying locomotive piston rods to the pistons, and also for removing the pistons from the rods, but it is also adaptable to a wide

range of miscellaneous forcing work. In forcing on a piston, it is set on the lower base with the rod passing up through the press base proper, the pressure then being applied from the end of the piston rod, forcing it into the piston. When the press is used for forcing the piston off the rod, the piston, with the rod, is hung on the press base proper and the pressure applied from the end of the rod, forcing the rod out of the piston. More pressure is required for the latter operation and the upper part of the press is thus designed for a maximum pressure of 100 tons, while the lower portion is designed for a maximum pressure of only 50 tons.

The usual method of installing this machine is to erect it so that the base of the press proper is just above the floor level, the lower parts being under the floor. It is self-contained, the pressure being furnished by a direct motor-driven horizontal double-plunger pump with double gear reduction. A tee screw hydraulic operating valve controls the pressure from this pump to the press cylinder.

The diameter of the press ram is 10 in. It has a run of 22 in. and is equipped with a rack and pinion attachment for raising or lowering the ram upon the work. Thus various lengths of work may be admitted to the press and the pressure instantly applied at the first stroke of the pump. The daylight space for the upper portion of the press is 36 in. and for the lower part 50 in., making the total daylight or working space 86 in. Steel is used for all the principal castings; cold rolled steel shafting 4 in. in diameter is used for the strain rods.

### GRINDING MACHINE

The Modern Tool Company, Erie, Pa., has added to its line of self-contained grinding machines two additional sizes, an 8 in. by 18 in. and an 8 in. by 30 in. With the exception of the center distances and the wheel drive on the 8 in. by 30 in. the machines are similar.

Economy of floor space, compactness, ease of operation, and comparative simplicity of mechanism are distinguishing

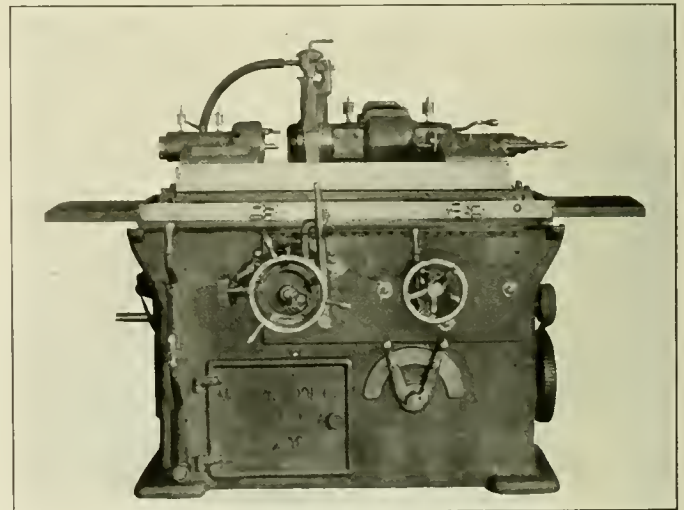

Front View of the 8-in by 18-in Machine

features of these machines. All operating levers are concentrated on the front of the machine, and there is nothing extending above the wheel stand, all mechanisms being contained within the machine. The machines are essentially manufacturing grinders for straight or taper cylindrical work in quantities. The bed is a one-piece casting, rigidly braced. V and flat guides are used throughout on the sliding table, swivel table and under the wheel stand. The base rests upon three points.



The standard wheel spindle is  $2\frac{1}{4}$  in. in diameter running in phosphor bronze bearings  $6\frac{1}{4}$  in. long and driven by a belt  $4$  in. wide. For heavy work, the wheel spindle is made  $3\frac{1}{4}$  in. in diameter. The wheel stand pile is bolted to the bed of the machine and is of generous proportions. The wheel center is of large diameter, has a long bearing in the spindle, and will take any of the recognized standard grinding wheels. Wheels used on the standard machines are 16 in. diameter up to 3 in. face; wheels used on the heavy drive are 18 in. up to 4 in. face.

The table drive is of a simplified type, eliminating what was formerly known as the table transmission. This drive consists of a single unit contained in the bed of the machine, which is a combination of table drive and transmission.

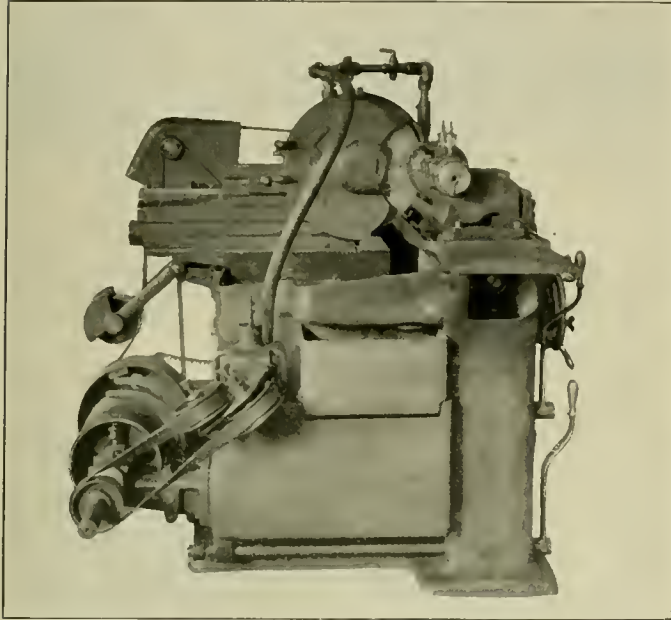

End View, Showing Main Drive and Pump

All-steel spur gears are used for the reversing mechanism. The power table traverse is controlled by a lever immediately to the left of the table hand wheel, which provides for starting or stopping the table at any point in its stroke. When the table is under power the hand wheel is automatically disengaged, and when the power is removed the hand wheel is automatically engaged for traversing the table by hand. There are four table feeds, derived from a single unit gear box, and controlled by a lever at the right immediately below the table hand wheel.

The automatic cross feed is positive in its action and is simplified without losing any of its features. This can be set for a reduction of any amount from .0005 in. to .005 in. at either or both ends of the table reverse. This latter feature is especially advantageous when grinding against a shoulder. The feed is automatically thrown out when work is ground to size and a positive stop is provided for use when feeding by hand. The cross feed hand wheel is graduated in .0005 in. in plain view of the operator. The headstock is of a new design, being driven from a shaft under the sliding table. This shaft is driven by a pulley which is carried in a bracket on the bed, on which power is taken from the gear box.

The wheel truing device is mounted on the footstock and is adjustable to all diameters within the range of the machine so that the wheel can be trued without removing the work from the centers. The pump is of the fan type and revolves in a horizontal plane and is kept immersed so that it is constantly primed and no packing is required.

The machines have eight work speeds from 26 to 390

r.p.m., and four table feeds from 22 in. to 104 in. per minute. The feeds and speeds are entirely independent of each other. The new sizes have the single constant speed drive used on the larger machines, which reduces the cost when equipping the machines with motors.

### BAILEY BOILER METER

The Bailey boiler meter, which is made by the Bailey Meter Company, Boston, Mass., is a combination of three separate meters in one casing, each drawing its own record in a distinctive color on a 12 in. chart. This meter records the rate of steam output from the boiler, the rate of air flow through the furnace, and the condition of the fuel bed. It also correlates and compares these factors in such a manner that any fireman can readily understand the readings and inform himself as to any needed change in the furnace or draft conditions.

The steam flow is recorded by a pen drawing a red record in the center section of the chart, the graduations being in per cent of the boiler's rated capacity on a uniform scale. The air flow is recorded by a pen drawing a blue record. This pen is located so that it travels immediately in front of and records just ahead of the steam flow. It is operated by the draft differential between the firebox and the uptake, but

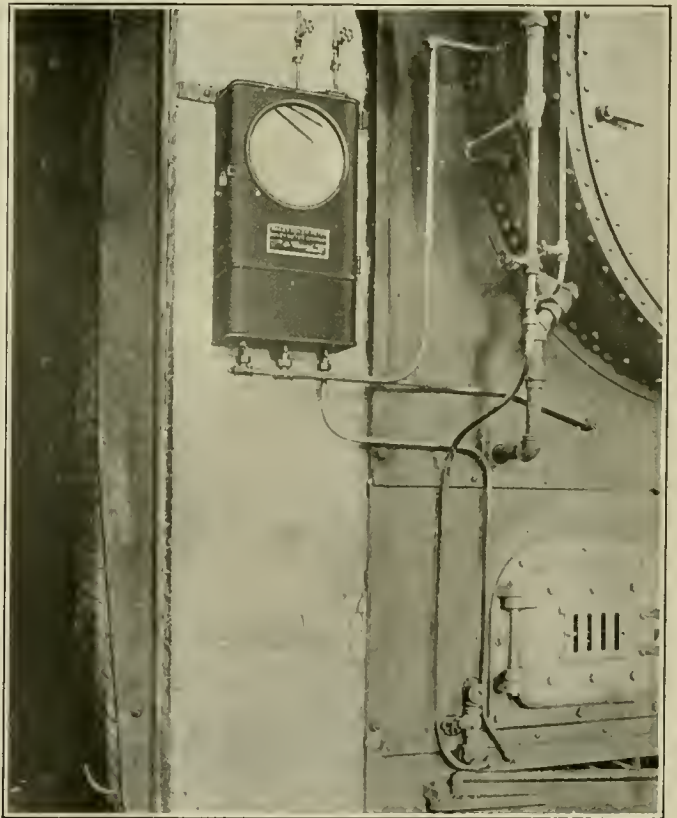

Bailey Meter in Position

instead of reading in terms of draft it reads in terms of steam output. In other words, it gives the same reading and draws a coincident record with the steam flow so long as the right amount of air is used for combustion. If the air flow reads more than the steam flow it shows too much air and corresponds to low carbon dioxide; if it reads less than the steam flow it means insufficient air and loss due to unburned gases. This is based upon the principle that air is a fuel just as much as is coal, and a certain evaporation should be obtained per pound of air. This standard is determined for each boiler and the meter adjusted accordingly.

The furnace indicator drawing a record on the outer sec-

tion of the chart shows the conditions of the fuel bed. The fire is of the right thickness when this pen is on the shaded band, too thick when above and too thin when below. This also is adjusted to individual conditions after extensive tests have been made to determine the best kind of fire to carry. This indicator is operated by draft pressures and is in reality a measure of the resistance of the fuel bed to the flow of air. It should not be confused with the drop in draft pressure across the fuel bed, for it includes the draft pressure in the uptake as well as the firebox and ash pit in such a way as to eliminate the effect due to the intensity of the draft or the rate of flow of air and responds only to changes in condition

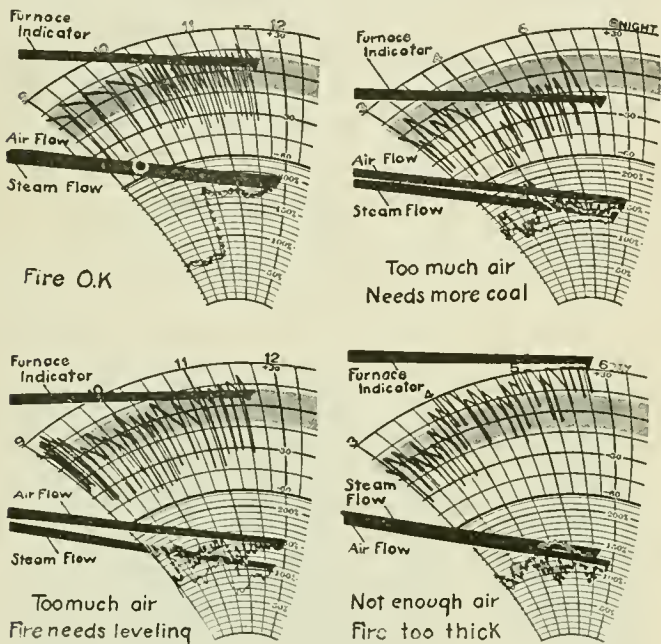

Samples of the Records Obtained

of the fuel bed. That is, the pen does not move when the damper opening or draft pressure varies from maximum to minimum unless the fire changes, but when the fire burns too thin or develops holes, the recorder shows it regardless of the intensity of the draft.

Every part of the meter responds promptly to changes in any of the operating conditions. In a hand fired furnace it plainly shows each opening of the fire door, cleaning of the fire, etc.

### SPECIAL GLASS TO PREVENT ACCIDENT

The Hires Turner Glass Company, Philadelphia, is furnishing what is called Superglass for use in moving vehicles. It is intended to prevent accidents due to flying broken glass. It is made up of two pieces of polished plate glass between which is a sheet of celluloid of the proper shade for the uses to which it might be subjected. The glass and celluloid are welded together under high temperature and pressure. If a sheet of this glass is struck a powerful blow by some hard missile, it is claimed that it will only crack into hair lines, with no flying glass or splinters.

**SPACING BOLT HOLES IN CASTINGS.**—Holes in castings should be located at a certain minimum distance from the edge of the casting. A drilled bolt hole should be located at least one and one-fourth diameter from the edge of the casting; a cored bolt hole, one and one-half diameter; a drilled rivet hole, one and three-fourths diameter; and a cored rivet hole, two diameters from the edge of the casting —*Machinery*.

### COLD METAL SAWING MACHINE

The accompanying photographs show a recent design of the O. M. S. cold metal sawing machine which has been placed on the market by the Vulcan Engineering Sales Company, Chicago.

The saw and gear arbor are of hammered, open hearth, .60 carbon steel, fitted by scraping. The teeth are cut from the solid, and being staggered, back-lash and resultant chatter of the saw blade are reduced to a minimum. The saw and

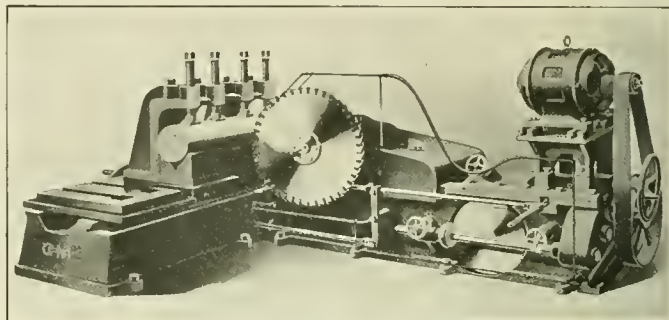

Q. M. S. Cold Metal Sawing Machine

gear arbor run in hard bronze bearings. The worm is of hardened steel, and roller bearings take the end thrust. The worm wheel is of two-piece construction, having steel center with a special bronze rim. The worm and worm wheel are encased and run in grease.

The carriage is of box section construction. A spline shaft prevents the spline in the main or worm shaft coming in contact with the bronze bearings. The feed is obtained by a combination of a friction disc and gears, providing a

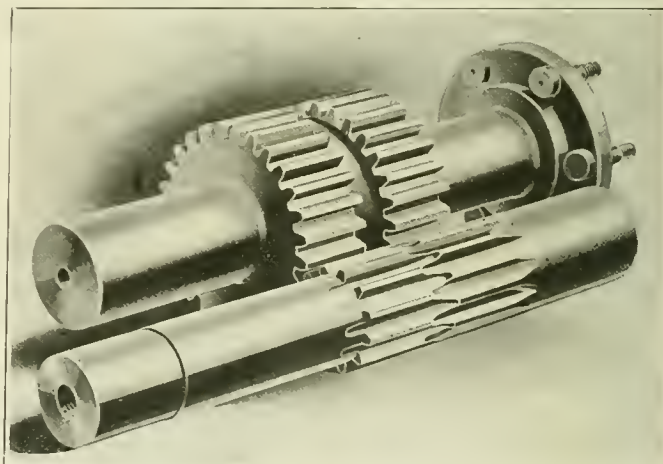

Staggered Tooth Construction of Saw and Gear Arbors

range of from 5/16 in. to 2 1/2 in. per minute. The friction wheel automatically sustains the proper contact with the friction disc, insuring maximum power. The peripheral speed change is instantaneous and is arranged to run either at 30 and 50 ft. or 40 and 60 ft. per minute as desired.

All gears run in oil and the inner bearings are lubricated by oil pipes leading to the outside of the machine. An oil trough is cast around the work table and a gear pump provided for lubricating the saw table.

**DARKEST GUATEMALA.**—As a result of the war, Ocos, Guatemala will lose its electric-lighting plant. About nine years ago the Kosmos liner Sesostris was beached near there, and the chief engineer arranged to supply the town with electricity, after it was decided not to refloat the ship. Now the demand for vessels has reached a point where it appears profitable to dig a canal and float the ship back to sea. —*Electrical Review*.

# Railway Mechanical Engineer

(Formerly the RAILWAY AGE GAZETTE, MECHANICAL EDITION  
with which the AMERICAN ENGINEER was incorporated)

PUBLISHED ON THE FIRST THURSDAY OF EVERY MONTH BY THE  
SIMMONS-BOARDMAN PUBLISHING COMPANY

EDWARD A. SIMMONS, *President*                      L. B. SHERMAN, *Vice-President*  
HENRY LEE, *Vice-President and Treasurer*      M. H. WIUM, *Secretary*  
F. H. THOMPSON, *Business Manager*  
WOOLWORTH BUILDING, NEW YORK, N. Y.

Chicago: Transportation Bldg.                      Cleveland: Citizens' Bldg.  
London: Queen Anne's Chambers, Westminster.

ROY V. WRIGHT, *Editor*  
A. C. LOUDON, *Managing Editor*

R. E. THAYER, *Associate Editor*                      C. B. PECK, *Associate Editor*

Entered at the Post Office at New York, N. Y., as mail matter of the  
second class.

Subscriptions, including the eight daily editions of the *Railway Age Gazette* published in June in connection with the annual conventions of the Master Car Builders' and American Railway Master Mechanics' Associations, payable in advance and postage free: United States, Canada and Mexico, \$2.00 a year; Foreign Countries (excepting daily editions), \$3.00 a year; Single Copy, 20 cents.

WE GUARANTEE, that of this issue 8,500 copies were printed; that of these 8,500 copies, 7,744 were mailed to regular paid subscribers, 50 were provided for counter and news companies' sales, 426 were mailed to advertisers, exchanges and correspondents, and 240 were provided for new subscriptions, samples, copies lost in the mail and office use; that the total copies printed this year to date were 57,600, an average of 7,200 copies a month.

The RAILWAY MECHANICAL ENGINEER is a member of the Audit Bureau of Circulations.

VOLUME 90

JULY, 1916

NUMBER 7

## CONTENTS

EDITORIALS:	
Automatic Fire Doors.....	331
Saving Oil and Wasting Fuel.....	331
The Weight of Steel Freight Cars.....	331
How Can the Car Designer Improve?.....	331
Mechanical Stokers and Fuel Economy.....	332
Superheated Steam in Switching Locomotives.....	332
The Cost of Locomotive Maintenance.....	332
Can You Do This?.....	332
Four-Wheel Trucks for Passenger Cars.....	333
Lateral Motion Driving Boxes and Side Play.....	333
New Books.....	333
COMMUNICATIONS:	
Horizontal Sheathing for Box Cars.....	334
More from Tobesura Weno.....	334
College Men in the Mechanical Department.....	334
GENERAL:	
What Is Heat Treated Steel?.....	335
Keeping Track of Service Tests.....	337
Locomotive Superheater Performance.....	339
Large Consolidation Locomotive.....	343
Interesting Facts Concerning Grade Resistance and Car Friction.....	345
Examples of Recent Locomotives.....	346
CAR DEPARTMENT:	
Suggestions for Improvement in Car Design.....	347
Carpet Stretcher.....	348
Boston & Maine Steel Coaches.....	349
Air Brake Maintenance.....	352
The Work of the Car Inspector.....	353
Steel Ore Car.....	354
Empty and Load Brake Equipment.....	355
Trap Doors on Observation Cars.....	357
Terminal Car Cleaning Yards.....	357
Coach Window Raiser.....	358
SHOP PRACTICE:	
Material Delivery at the Macon Shops.....	359
A Reclaimed Rail Saw.....	359
Fitting Driving Box Brasses.....	360
Waste and Abuse of Brass and Bronze.....	361
Santa Fe Apprentice Conference.....	363
Analyzing Engine Failures.....	366
Thomas-Langley Gage Cock.....	367
The Operation of a Large Engine Terminal.....	368
A Locomotive Inspection System.....	369
Removing Air Pockets from Reservoirs.....	372
Getting Results from a Big Engine Terminal.....	372
NEW DEVICES:	
Induction Motor for Turntables and Transfer Tables.....	373
Beyer Barometric Condenser.....	373
Hydraulic Forcing Press.....	374
Grinding Machine.....	374
Bailey Boiler Meter.....	375
Special Glass to Prevent Accident.....	376
Cold Metal Sawing Machine.....	376
NEWS DEPARTMENT:	
Notes.....	377
Meetings and Conventions.....	378
Personals.....	379
Supply Trade Notes.....	381
Catalogues.....	384

The Pennsylvania Railroad, in consequence of the destruction by fire of its large grain elevator at Baltimore, is sending trainloads of grain to the new elevator of the Western Maryland, on the south side of the harbor.

The Southern Pacific has given notice that owing to the Mexican situation all of its lines south of the border are closed and that the company is not in position to accept shipments for points in Mexico via Nogales or Naco.

According to a statement issued by the United States Geological Survey, the use of petroleum as locomotive fuel increased 18 per cent last year. It is said that 37,000,000 barrels were used as against 30,000,000 the year before. Oil fuel is used on 40 railroads in the United States.

The operation of open-top observation cars through the Royal Gorge and the Black Canyon of the Gunnison in Colorado has been resumed for the summer by the Denver & Rio Grande. All trains passing through these points by daylight have these cars.

At Princeton, N. J., an agent of the Pullman Company has been engaging students and graduates of the University for service as conductors of parlor cars, apparently to fill up the ranks for the summer resort business. It is said that the salary to be paid will be \$77 a month, and that there were a large number of applicants. Those under 25 years of age were not accepted.

By direction of the Commission on Car Service of the American Railway Association a force of 20 inspectors has been organized by the secretary of the commission to develop actual violations of Car Service Rules 1 to 4, inclusive, by inspection of records as well as by field investigation. This action was authorized by the American Railway Association at its meeting on May 17.

The College of Engineering of the University of Illinois, Dr. W. F. M. Goss, dean, at the commencement on June 14, conferred 10 bachelor degrees in railway engineering, 39 in civil engineering, 43 in electrical engineering and 44 in mechanical engineering, in addition to degrees in architecture,

mining, etc., 222 in all. In addition there were conferred by the departments of engineering, 21 master's degrees, 21 professional degrees and 3 doctor's degrees.

In a fire at the Pennsylvania Railroad piers at Canton, Baltimore, Md., on the afternoon of June 13, grain elevator No. 3 was destroyed together with much other property, and a number of employees and other persons, said to be ten or more, were killed. Over 30 other persons were injured by burns and falls. The property loss is estimated at \$2,000,000. The ore pier and many freight cars were destroyed and several vessels lying at the piers were badly damaged.

Will Leggins, of Thomasville, Ga., has received a medal of honor from President Wilson upon recommendation of the Interstate Commerce Commission. On November 11, 1915, a pay train of the Atlantic Coast Line was derailed in the yards at Thomasville, and Leggins employed in the shops, 300 feet distant, hearing a crash, ran to the overturned locomotive, under which was pinioned Engineman Taylor. Leggins fought his way to the injured man, shielded his body, called for a bar and extricated him. Taylor died later. Leggins' act was commended by the President in a letter accompanying the medal.

**CORRECTION**

In the locomotive table published on page 235 of the May, 1916, number of the *Railway Mechanical Engineer*, the Delaware & Hudson Consolidation was shown as using bituminous coal. This is incorrect, as the engine was designed and built for the burning of pulverized anthracite culm in suspension.

**ORDERS FOR CARS AND LOCOMOTIVES IN JUNE**

The outstanding feature regarding the orders for cars and locomotives reported during June was the buying of passenger cars, orders having been placed for 164 cars. This was more than have been ordered any month this year, with the exception of January, when 310 cars were ordered, of which 200 were subway cars for the New York Municipal Railway Corporation. It should be noted, however, that the orders for passenger cars reported during December, 1915, totaled 508. The orders for both cars and locomotives reported during the month were as follows:

	Locomotives	Freight cars	Passenger cars
Domestic .....	174	3,531	164
Foreign .....	213	2,140	...
	387	5,671	164

Among the important locomotive orders were the following:

Road	Number	Type	Builder
Chesapeake & Ohio.....	25	Mallet	American
	25	Mallet	Lima
Lehigh Valley .....	40	Santa Fe	Baldwin
	30	Pacific	Baldwin
New York Central .....	25	Mallet	American
Texas & Pacific.....	8	Santa Fe	Baldwin
Egyptian State Railways.....	24	Six-wheel (0-6-0)	American
French Government .....	100	Narrow gage	Baldwin
Russian Government .....	70	Narrow gage	American

The freight car orders included the following: Baltimore & Ohio, 1,000 box cars, Haskell & Barker Car Company; Canadian Government Railways, 500 box cars, Canadian Car & Foundry Company; Denver & Rio Grande, 500 box cars, Pullman Company; Southern Railway, 1,000 box cars, Lenoir Car Works; and the United Railways of Havana, 300 flat and 200 box cars, Pressed Steel Car Company; 140 flat, Standard Steel Car Company; 100 cane, 100 flat and 100 narrow gage cars, American Car & Foundry Company.

The passenger car purchases included orders placed by the Chicago & North Western for 10 baggage cars, 15 smoking cars, 24 coaches, 5 baggage and mail cars and 3 postal cars, American Car & Foundry Company; Delaware, Lackawanna & Western, 45 coaches and 10 passenger and baggage cars

for suburban service, Pullman Company; New York Central, 12 multiple unit cars, Standard Steel Car Company; Pennsylvania Lines West, 10 baggage and mail cars, Pullman Company, and Texas & Pacific, 8 baggage and mail cars, American Car & Foundry Company.

**FOREIGN SPECIFICATIONS FOR RAILWAY MATERIAL**

With the object of placing in convenient and accessible form before those in the United States interested in or responsible for railway materials, the Bureau of Standards, Department of Commerce, in connection with its investigation of failures of railway material, has obtained, through the courtesy of the state department, copies of specifications for railway material—rails, axles, wheels, and tires—used in several European countries. These specifications are given in full, together with a digest and discussion, in Technologic Paper No. 61, just issued. The available data concerning the types and weights of foreign railway equipments together with those concerning derailments and accidents abroad, are also included in the publication. Persons interested may obtain copies of the paper, which is entitled "Foreign Specifications for Railway Material," without charge upon application to the Bureau of Standards, Washington, D. C.

**MEETINGS AND CONVENTIONS**

*Chief Interchange Car Inspector's and Car Foreman's Association.*—The annual convention of the Chief Interchange Car Inspector's and Car Foreman's Association will be held in Indianapolis, Ind., October 3, 4, and 5, 1916.

*American Railway Tool Foreman's Association.*—The convention of the American Railway Tool Foreman's Association will be held on August 24-26, at the Hotel Sherman, Chicago. The following subjects will be presented by the committees: Heat Treatment of Steel, Henry Otto, chairman; Special Tools for Steel Car Repairs—Devices for Reclaiming Material, J. W. Pike, chairman; Special Tools and Devices for the Forge Shop, G. W. Smith, chairman; Emery Wheels as Applied to Locomotive Repairs, A. Sterner, chairman; Jigs and Devices for Enginehouses, F. D. West, chairman.

*The Traveling Engineers' Association.*—The next annual convention of The Traveling Engineers' Association will be held on September 5-8, at Chicago, Ill. The following is a list of the subjects to be discussed at this meeting: Stoking and Lubricating, and Their Effect on the Cost of Locomotive Operation; Superheaters and Brick Arches on Large Locomotives; The Prevention of Smoke and Its Relation to the Cost of Fuel and Locomotive Repairs; Recommended Freight Train Practice; Assignment of Power from the Standpoints of Efficient Service and Economy in Fuel and Maintenance.

*Master Blacksmiths' Association.*—The twenty-fourth annual convention of the International Railroad Master Blacksmiths' Association will be held at the Hotel Sherman, Chicago, August 15-17, 1916. The following subjects will be discussed: Frame Making and Repairing, Drop Forgings, Tools and Formers, Spring Making and Repairing, Frogs and Crossings, Carbon and High Speed Steels, Case Hardening, Oxy-Acetylene and Electric Welding, Shop Kinks, Heat Treatment of Metals, Piece Work and other Methods, Reclaiming of Scrap Material, Flue Welding.

*International Railway General Foremen's Association.*—The twelfth annual convention of the International Railway General Foremen's Association will be held at the Hotel Sherman, Chicago, on August 29 to September 1, and not in July as formerly. The following is the list of topics with the name of the chairman of the committee which is to prepare them: Car Department Problems, E. E. Griest, chair-

man; Counterbalancing of the Locomotive and Fitting Up of the Frames and Binders, H. C. Warner, chairman; Classification of Repairs, Robert Wilson, chairman; Relation of the Foreman to the Men, T. E. Freeman, chairman.

*American Railroad Master Tinnners, Coppersmiths and Pipefitters' Association.*—At the annual convention of the American Railroad Master Tinnners, Coppersmiths and Pipefitters Association held in Chicago May 22 to 24, the following officers were elected for the ensuing year: President, W. J. Moffett, New York Central Lines, Indianapolis, Ind.; first vice-president, G. B. Hosford, Missouri Pacific Railway, Sedalia, Mo.; second vice-president, W. W. Nash, Illinois Central, Water Valley, Miss.; third vice-president, T. E. Holderby, Chesapeake & Ohio, Huntington, W. Va.; secretary-treasurer, O. E. Schlink, Chesapeake & Ohio, Peru, Ind.

*Master Car & Locomotive Painters' Association.*—The next annual convention of the Master Car and Locomotive Painters' Association will be held at Atlantic City, N. J., on September 12-14, 1916. The list of subjects to be presented are as follows: The Initial Treatment and Maintenance of Steel Passenger Equipment Roofs, etc.; Headlinings Painted White or in Very Light Shades—How Should They Be Treated and Should They Be Varnished; Is It Economy to Purchase Paints Made on Railroad Specifications; The Shopping of Passenger Cars for Classified Repairs; Railway Legislation and Its Effect on Business. The following questions will also be discussed: To what extent is it necessary to remove trimmings from passenger car equipment undergoing paint shop treatment? How does the hot water and oil method of cleaning locomotives at roundhouses affect the painted parts? Is there any advantage in painting or oiling the interior of new or old steel gondola and hopper cars? Is there anything superior to varnish remover for removing paint from a steel passenger car, considering labor and material costs? Is there anything superior to soap for the cleaning of passenger equipment cars preparatory to painting and varnishing?

The following list gives names of secretaries, dates of next or regular meetings and places of meeting of mechanical associations:

- AIR BRAKE ASSOCIATION.—F. M. Nellis, Room 3014, 165 Broadway, New York City.
- AMERICAN RAILROAD MASTER TINNERS', COPPERSMITHS' AND PIPEFITTERS' ASSOCIATION.—O. E. Schlink, 485 W. Fifth St., Peru, Ind.
- AMERICAN RAILWAY MASTER MECHANICS' ASSOCIATION.—J. W. Taylor, Karpen Building, Chicago.
- AMERICAN RAILWAY TOOL FOREMEN'S ASSOCIATION.—Owen D. Kinsey, Illinois Central, Chicago. Convention, August 24-26, 1916.
- AMERICAN SOCIETY FOR TESTING MATERIALS.—Prof. E. Marburg, University of Pennsylvania, Philadelphia, Pa.
- AMERICAN SOCIETY OF MECHANICAL ENGINEERS.—Calvin W. Rice, 29 W. Thirty-ninth St., New York.
- ASSOCIATION OF RAILWAY ELECTRICAL ENGINEERS.—Joseph A. Andreucetti, C. & N. W., Room 411, C. & N. W. Station, Chicago.
- CAR FOREMEN'S ASSOCIATION OF CHICAGO.—Aaron Kline, 841 Lawlor Ave., Chicago. Second Monday in month, except June, July and August, Hotel La Salle, Chicago.
- CHIEF INTERCHANGE CAR INSPECTORS' AND CAR FOREMEN'S ASSOCIATION.—W. R. McMunn, New York Central, Albany, N. Y. Convention, October 3-5, Indianapolis, Ind.
- INTERNATIONAL RAILWAY FUEL ASSOCIATION.—J. G. Crawford, 547 W. Jackson Blvd., Chicago.
- INTERNATIONAL RAILWAY GENERAL FOREMEN'S ASSOCIATION.—William Hall, 1126 W. Broadway, Winona, Minn. Convention, August 29-Sept. 1, 1916, Hotel Sherman, Chicago.
- INTERNATIONAL RAILROAD MASTER BLACKSMITHS' ASSOCIATION.—A. L. Woodworth, Lima, Ohio. Convention, August 15-17, 1916, Hotel Sherman, Chicago.
- MASTER BOILER MAKERS' ASSOCIATION.—Harry D. Vought, 95 Liberty St., New York.
- MASTER CAR BUILDERS' ASSOCIATION.—J. W. Taylor, Karpen Building, Chicago.
- MASTER CAR AND LOCOMOTIVE PAINTERS' ASSOCIATION OF U. S. AND CANADA.—A. P. Dane, B. & M., Reading, Mass. Convention, September 12-14, 1916, "The Breakers," Atlantic City, N. J.
- NIAGARA FRONTIER CAR MEN'S ASSOCIATION.—E. Frankenberger, 623 Brisbane Building, Buffalo, N. Y. Meetings, third Wednesday in month, New York Telephone Bldg., Buffalo, N. Y.
- RAILWAY STOREKEEPERS' ASSOCIATION.—J. P. Murphy, Box C, Collinwood, Ohio.
- TRAVELING ENGINEERS' ASSOCIATION.—W. O. Thompson, N. Y. C. R. R., Cleveland, Ohio. Convention, September 5-8, 1916, Chicago.

## PERSONAL

### GENERAL

P. A. CAMPBELL, chief clerk in the machinery department of the Chicago Junction Railway has been appointed assistant superintendent of motive power at Chicago, Ill.

J. DICKSON has been appointed superintendent of motive power of the Spokane, Portland & Seattle, the Oregon Trunk, the Pacific & Eastern, the Spokane & Inland Empire, the Oregon Electric, and the United Railways, with headquarters at Portland, Ore. Mr. Dickson was born on June 30, 1872, at Montreal, Que., and was educated in the grammar and night schools of his native town, also at St. Paul, Minn. He began railway work in 1884 as machinist apprentice on the Great Northern, remaining in the service of that road as an apprentice and machinist until 1889. He was later in the service of the Chicago & Eastern Illinois as a machinist



J. Dickson

at Huntington, Ind., and with the Roanoke Machine Works, Roanoke, Va., until 1891, when he returned to the Great Northern, and served consecutively as machinist, air brake repair man and draftsman until 1898. He was then for two years instructor in Mechanic Arts High School, St. Paul, Minn. In 1900 he again returned to the service of the Great Northern as general air brake instructor. Two years later he was appointed superintendent of shops, and in 1904 was made master mechanic of the Dakota division of the same road. In 1908 he entered the service of the Spokane, Portland & Seattle as master mechanic during the construction of that road. He was promoted to general master mechanic in February, 1914, with jurisdiction also over the Oregon Trunk, the Oregon Electric and the United Railways. The following May his jurisdiction was extended over the Spokane & Inland Empire and the Pacific & Eastern and later also over the electrical and signal departments of all these roads.

JAMES FITZMORRIS, master mechanic of the Chicago Junction Railway has been appointed superintendent of motive power with office at Chicago.

ELLIOTT SUMNER, master mechanic of the Pennsylvania Railroad at West Philadelphia, Pa., has been appointed superintendent of motive power with office at Williamsport, succeeding I. B. Thomas.

A. G. WILLIAMS, assistant master mechanic of the Pennsylvania Lines West, has been appointed assistant engineer of motive power, succeeding L. B. Jones, transferred.

### MASTER MECHANICS AND ROAD FOREMEN OF ENGINES

O. H. ATTRIDGE, master mechanic of the Atlanta & West Point and the Western Railway of Alabama, has been appointed master mechanic of the Georgia Railroad, with office at Augusta, Ga., succeeding J. H. Gaston, resigned to go to another company.

FRANK J. BAUER, locomotive foreman of the Great Northern at Kelly Lake, Minn., has been appointed master me-

chanic of the Breckenridge division, at Breckenridge, Minn., succeeding S. J. Fero, assigned to other duties.

J. C. BENSON has been appointed master mechanic of the Butte division of the Great Northern, at Great Falls, Mont., succeeding A. B. Ford, assigned to other duties.

J. H. GASTON, master mechanic of the Georgia Railroad at Augusta, Ga., has been appointed master mechanic of the Atlanta & West Point and the Western Railway of Alabama, with office at Montgomery, Ala., succeeding O. H. Attridge, resigned, to accept service elsewhere. Mr. Gaston was born at Quincy, Ill., in 1872, and was educated in the public schools. He entered railway service in 1888 with the Louisville & Nashville at Louisville, Ky. He later served on the Cleveland, Cincinnati, Chicago & St. Louis at Indianapolis, Ind.; the Illinois Central at Paducah, Ky., and the Georgia Railroad at Augusta, Ga., until his recent appointment mentioned above.

C. GRIBBIN, formerly locomotive foreman of the Canadian Pacific at Toronto, Ont., has been appointed district master mechanic, District 4, Ontario division, at Toronto.

WALTER HAMILTON has been appointed assistant master mechanic, Pennsylvania Lines West, with headquarters at Ft. Wayne, Ind., succeeding F. T. Huston, promoted.

ROBERT SCHULE has been appointed master mechanic of the Montana division of the Great Northern, at Havre, Mont., succeeding J. C. Benson, transferred.

GEORGE W. WEBER has been appointed master mechanic of the Minot division of the Great Northern, at Minot, N. D., succeeding E. English, assigned to other duties.

#### CAR DEPARTMENT

F. T. HUSTON, assistant master mechanic of the Pennsylvania Lines West at Fort Wayne, Ind., has been appointed general car inspector of the northwest system of the Pennsylvania Lines West, succeeding O. J. Parks, resigned.

A. H. McCOWAN, supervisor of car work of the Canadian Northern Lines west of Port Arthur, Ont., has had his authority extended over the eastern lines.

J. RUDD, formerly assistant car foreman of the Canadian Northern at Winnipeg, Man., has been appointed car foreman at Kamsack, Sask., succeeding W. Millman, transferred.

R. J. WATTERS has been appointed assistant general air brake inspector of the Northern Pacific, succeeding D. A. McMillan, assigned to other duties.

C. WHEATON, formerly car foreman of the Canadian Northern at Port Arthur, Ont., has been appointed assistant car foreman at Winnipeg, succeeding J. Rudd, promoted.

#### SHOP AND ENGINE HOUSE

M. A. CARDELL, formerly locomotive foreman of the Canadian Northern at Tollerton, Alta., has been appointed locomotive foreman at Kamloops Jct., B. C., succeeding S. Vincent, transferred.

A. EDWARDS has been appointed assistant locomotive foreman of the Canadian Pacific at London, Ont., succeeding W. Wright, promoted.

A. T. HANNAH, formerly locomotive foreman of the Canadian Northern at Humboldt, Sask., has been appointed locomotive foreman at Hanna, Alta., succeeding N. McLean, transferred.

J. B. IRWIN has been appointed general foreman locomotive department of the Chicago, Burlington & Quincy at Edgmont, S. D., succeeding A. G. Pirie, transferred.

N. McLEAN, formerly locomotive foreman of the Canadian Northern at Hanna, Alta., has been appointed locomotive foreman at Humboldt, Sask., succeeding A. T. Hannah, transferred.

A. G. PIRIE has been appointed general foreman locomotive department Chicago, Burlington & Quincy at Alliance, Nebr., succeeding C. L. Emerson, resigned.

S. VINCENT, formerly locomotive foreman of the Canadian Northern at Kamloops Jct., B. C., has been appointed locomotive foreman at Tollerton, Alta., succeeding M. A. Cardell, transferred.

F. WILLIAMS has been appointed general foreman, locomotive and car departments, of the Wellsville & Buffalo, with office at Bladell, N. Y.

W. WRIGHT, formerly assistant locomotive foreman of the Canadian Pacific at London, Ont., has been appointed locomotive foreman at Toronto, Ont., succeeding C. Gribbin, promoted.

#### PURCHASING AND STOREKEEPING

H. A. CLARK has been appointed storekeeper of the Grand Trunk at Richmond, Que., succeeding M. E. Martin, enlisted for active service.

W. E. DOWNING has been appointed storekeeper of the Baltimore & Ohio at Connellsville, Md., succeeding C. G. Sutton.

H. J. McQUADE has been appointed purchasing agent of the Lehigh Valley, with headquarters at New York. Mr. McQuade entered the service of the Lehigh Valley as a boy, 29 years ago. His first work was as a clerk in the local offices in Philadelphia. In February, 1902, he was transferred to the general bookkeeping department, and in December, 1903, he was appointed chief clerk to the general auditor. He was elected assistant treasurer of the same road, with office at Philadelphia, Pa., in January, 1909, and remained in that position until June, 1910, when he left the service of the Lehigh Valley to take up other duties.

Mr. McQuade now returns to the service of the Lehigh Valley as purchasing agent, with headquarters at New York, as above noted.

F. A. MURPHY, district storekeeper of the Wheeling district of the Baltimore & Ohio, at Wheeling, W. Va., has been transferred to the Pittsburgh district, at Pittsburgh, Pa., succeeding E. W. Thornley.

E. A. PAUL has been appointed purchasing agent of the New Orleans Great Northern with office at New Orleans, La.

H. SHOEMAKER, storekeeper of the Baltimore & Ohio at Newark, Ohio, has been appointed district storekeeper of the Wheeling district, at Wheeling, W. Va., succeeding F. A. Murphy.

C. G. SUTTON, storekeeper of the Baltimore & Ohio at Connellsville, Md., has been appointed storekeeper at Newark, Ohio, succeeding H. Shoemaker.

I. B. THOMAS, superintendent of motive power of the Pennsylvania Railroad at Williamsport, Pa., has been appointed assistant purchasing agent at Philadelphia.

E. W. THORNLEY, district storekeeper of the Pittsburgh district of the Baltimore & Ohio at Pittsburgh, Pa., has been appointed general storekeeper at Baltimore, Md.



H. J. McQuade

## SUPPLY TRADE NOTES

Henry A. Sherwin, founder and chairman of the board of the Sherwin-Williams Company, died on June 25, at his home at Cleveland, Ohio.

George W. Wenz, for several years assistant purchasing agent of the Gould Coupler Company, Depew, N. Y., has been appointed purchasing agent of the company.

The executive departments of the Western Electric Company, Inc., at New York, has been moved from 463 West street to new offices in the Telephone & Telegraph Building at 195 Broadway.

William P. Harper, chief of the purchasing department of the Allis-Chalmers Manufacturing Company and president of the Northwestern Manufacturing Company, Milwaukee, died of apoplexy on May 27.

Edward G. Caughey, assistant chief engineer of the Youngstown Sheet & Tube Company, Youngstown, Ohio, has resigned to become general manager of the Pennsylvania Tank Car Company, Sharon, Pa.

William H. Yetman, for the past two years in charge of the western railroad department of the Pyrene Manufacturing Company, New York, has been appointed railroad sales

manager of the company for the entire United States. He succeeds E. L. Kent, who has resigned to become vice-president of the Metal Hose & Tubing Company. Mr. Yetman prior to his becoming associated with the Pyrene Manufacturing Company, two years ago, was hydraulic engineer of the Bethlehem Steel Corporation. His headquarters will be at Chicago. William D. Dorry, one of the company's star salesmen, will be in charge of

railway sales in the territory east of Pittsburgh, with headquarters in New York. Mr. Dorry was formerly with the National Biscuit Company.

The business and good will of the Commercial Acetylene Railway Light & Signal Company, New York, except the welding department, has been acquired by the AGA Railway Light & Signal Company, 80 Broadway, New York.

W. E. Greenwood has been appointed assistant manager of the railway sales and fuel oil department of the Texas Company, succeeding L. F. Jordan resigned. Mr. Greenwood's headquarters will be at 17 Battery place, New York City.

C. F. Herington, assistant engineer in the office of the chief mechanical engineer of the New York Central, has resigned to take a position with the Bonnot Company, of Canton, Ohio, as mechanical engineer of the powdered coal department.

The Edison Storage Battery Supply Company has opened a new sales office at New Orleans, La., and C. A. Luckey, who has heretofore been attached to the sales office of the Edison Storage Battery Company in Chicago has been appointed resident manager of the new office.

W. B. Dickson has been elected second vice-president of

the Midvale Steel & Ordnance Company. This is a new office. Mr. Dickson has resigned from his position as secretary, but will continue as treasurer. He has been succeeded as secretary by D. B. Gehley, now secretary of the Cambria Steel Company.

Henry M. Shaw, formerly eastern representative of the Gardner Machine Company, Beloit, Wis., has become associated with Sherritt & Stoer Company, Inc., 603 Finance building, Philadelphia, and will represent the company in connection with its regular line, giving special attention to the Gardner company's products.

The Pennsylvania Tank Car Company and the Pennsylvania Tank Line, Sharon, Pa., announce the election of L. F. Jordan as president, and A. S. Maitland as treasurer.

Mr. Jordan is a man of wide experience both as a railroad and supply man. He first entered railway service in 1895, as a clerk in the stores department of the Missouri Pacific at Kansas City, Kan., later being promoted to storekeeper in the same office. From 1901 to 1902 he was clerk in the office of the purchasing agent of the Kansas City Southern at Kansas City, Mo. From the latter date until 1905 he was clerk in the office of the general manager of the Kansas

City Southern at Kansas City, Mo. From Kansas City he went to Denver, Colo., where he was general storekeeper of the Denver & Rio Grande until 1905, when he returned to Kansas City as purchasing agent of the Kansas City Southern. He left railroad service in 1912 to become assistant manager of the railroad and fuel oil department of the Texas Company, Chicago.

Thomas M. Derickson, at present general manager of the F. B. Zieg Manufacturing Company, will become general sales manager of the A. G. A. Railway Light & Signal

Company. Mr. Derickson was born at Meadville, Pa., in 1866. He served his apprenticeship in the Erie shops at Meadville, but later studied civil engineering, and for a while was in the engineering department of the Erie Railroad. Subsequently he engaged in railroad and land surveying in the south, and at one time was also general manager of the Lookout Incline Railway on Lookout Mountain. He was later sales manager of the Champion

Iron Works and subsequently became general manager of the Memphis district of the Bell Telephone Company, and then general sales manager of the Galion Iron Works, Galion, Ohio. As noted above, he is at present general man-



W. H. Yetman

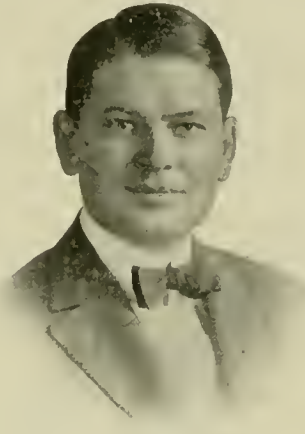

L. F. Jordan



T. M. Derickson

ager of the F. B. Zieg Manufacturing Company, Frederickstown, Ohio, manufacturers of cast iron culvert pipe and the Panama line of road machinery.

W. H. Ivers, formerly with the Baldwin Locomotive Works, has been appointed southwestern representative of the Gold Car Heating & Lighting Company, with headquarters at St. Louis, Mo., succeeding George F. Ivers, who has resigned to become manager of the railway supply department of Shapleigh Hardware Company, St. Louis, Mo.

At a meeting of the board of directors of the American Brake Shoe & Foundry Company, New York, May 17, Otis H. Cutler, president of the company, was elected chairman of the board, and William G. Pearce, vice-president, was elected president. James S. Thompson, William S. McGowan and Clifton D. Pettis were elected vice-presidents.

George T. Ramsey, railroad representative of the Garlock Packing Company, New York, will take charge of the railroad department of Fearon, Daniels & Co., Inc., Shanghai, China. He will sail about August 1. Mr. Ramsey was at one time connected with the American Locomotive Company. He was later connected with the New York Central and also with the American Vanadium Company.

Joseph Thayer Gilman, first vice-president of the Goodwin Car Company, New York, died on June 11 at the age of 52 years. Mr. Gilman had been associated with the Goodwin Car Company since 1903. He was born at Framingham, Mass., in 1864. At the age of 20 he went to India with C. H. Bailey & Co., importers of goat skins, but returned in 1887 on account of ill health. The year following he went again to India and opened a house for Keen Sutterlee Co., Ltd. He later returned to the United States and became associated with John M. Goodwin of the Goodwin Car Company. In 1898, however, he went back to India and



J. T. Gilman

opened a house in Calcutta for the firm of Burk Brothers of Philadelphia, manufacturers of morocco. He again became associated with the Goodwin Car Company in 1903. He was for a time second vice-president, but later succeeded to the position of first vice-president. At the time of his death he was in charge of the design and construction of the Goodwin car and the making of all contracts for their lease and sale.

G. R. Delamater has been appointed fuel engineer at the Steelton plant of the Pennsylvania Steel Company. He will be in charge of all coal washings; the supervision of the coal stock, including coking, bituminous, gas, slack and anthracite coal, coke breeze and the disposition of these products to the various departments; sampling of coal; the deliveries of gas, tar, coke and coke breeze, and miscellaneous matters between the various operating departments and the Semet-Solvay Company.

The International Pulverized Fuel Corporation, New York, has filed an application for a charter in Delaware to carry on the business of mechanical engineers and the manufacture of machinery for producing gaseous materials for products for light and heat. The company is incorporated for \$100,000

and the names of the incorporators are V. Z. Carachristi, H. F. Ball, Bronxville, N. Y.; George L. Bourne, Mamaroneck, N. Y.; Samuel G. Allen, New York; J. E. Muhlfield, Scarsdale, N. Y.; LeGrand Parish, Mountain View, N. J., and J. S. Coffin, Englewood, N. J.

On June 6 the stockholders of the Barney & Smith Car Company, Dayton, Ohio, elected as directors A. Clifford Shinkle, Lawrence Maxwell, Charles L. Harrison, Edward L. Heinsheimer and H. W. Lithmann, of Cincinnati, Ohio; Eugene J. Barney, H. M. Estabrook, A. J. Stevens and J. S. Kiefaber, of Dayton. The new members, Messrs. Shinkle, Lithmann and Heinsheimer, succeed James L. O'Neil, of Pittsburgh, and E. L. Potter, of New York, retired, and John Ledyard Lincoln, of Cincinnati, deceased.

The Greenville Steel Car Company, Greenville, Pa., has recently been reorganized and F. L. Fay, formerly general manager, has been elected president and has acquired the controlling interest in the business. James G. Dimmick has been elected vice-president. The company is enlarging its plant to handle more business.

Frank L. Fay, the new president of the company, has been treasurer and general manager of the Greenville Steel Car Company and its predecessor, the Greenville Metal Products Company, since 1910. He was born at Cleveland on July 18, 1869, and was educated in the public schools of that city. He entered railway service in 1888 when he became a night watchman at the Cleveland shops of the Valley Railroad, now part of the Baltimore & Ohio. He also served for a while as an operator on that road. In 1889 he went to the New York, Chicago & St. Louis, serving for a time as a station agent and three years in the car accountant's office. From 1903 to 1910 he was car accountant on the Bessemer & Lake Erie. As noted above, he left railway service in the latter year to engage in the railway supply business.

James G. Dimmick, the new vice-president, was for some time in the construction department of the Pere Marquette. He has been engaged for some years in car construction work and in his new position will have charge of the production department and the management of the factory.

The Central Foundry Company, New York, announces that owing to the increasing importance of its western business, a vice-president of the company will maintain an office in Chicago, and that C. C. Todd, who, for many years, has



F. L. Fay



J. G. Dimmick



represented the company in the west and who about a year ago was elected a vice-president of the company, will open the Chicago office.

On June 15 the stock of the Kansas City Bolt & Nut Company was purchased by Kansas City interests from the J. H. Sternbergh estate of Reading, Pa. Coincident with the



G. T. Cook

transfer of the property the following officers were elected: George T. Cook, president; Solomon Stoddard, vice-president and general manager; H. R. Warren, secretary and treasurer. The board of directors includes Messrs. Cook, Stoddard and Warren, and A. L. Gustin, president of the Gustin-Bacon Manufacturing Company of Kansas City, and E. A. Nixon, vice-president of the Western Tie & Timber Company, St. Louis, Mo. The company has been in exist-

ence since 1888, has a plant which covers 15 acres of ground and has an annual output of 3,000 carloads of finished material per year. It employs from 650 to 750 men, and has a distributing payroll running approximately from \$500,000 to \$600,000 per year.

The new organization is increasing the finances of the company and many improvements in the equipment of the plant are contemplated.

George T. Cook, the new president, was born in Kansas City, Mo., October 14, 1871. He was educated in the public schools of Kansas City and graduated from the University of Kansas. He was in the purchasing department of the Kansas City, Fort Scott & Memphis for several years, and moved to St. Louis at



S. Stoddard

the time the Kansas City, Fort Scott & Memphis was absorbed by the St. Louis & San Francisco. He remained in St. Louis about a year and left to go with the Kansas City Bolt & Nut Company, as general sales manager in June, 1902. He resigned from the Kansas City Bolt & Nut Company in 1910, however, but continued in the railway supply business in Kansas City. On June 15, 1916, he was elected president of the Kansas City Bolt & Nut Company, as above noted.

Solomon Stoddard, vice-president and general manager, was born in Boston, Mass., and educated in Trinity College, Stratford, Conn. He entered the service of the Kansas City Bolt & Nut Company in a minor position in February, 1900, and has worked up to the position of vice-president and general manager.

On May 25 a special meeting of the stockholders of the Pyle-National Electric Headlight Company was held at Jersey City, N. J., for the purpose of changing the name of the

company to the Pyle-National Company. The change was made principally because the company is now manufacturing and selling several other devices besides electric headlights, among them the Young valve and valve gear, and that its business in these other lines is growing so rapidly that it is no longer distinctively a headlight company.

P. J. Ford, for years buyer and department manager for Crerar, Adams & Company of Chicago, has organized the P. J. Ford Company with office and store at 619-621 West Washington street, Chicago, and has the selling agency for the Ford Chain Block & Manufacturing Company of Philadelphia, the Indiana Foundry Company, Ltd., of Indiana, Pa., manufacturers of the Sutton sand drier, and several heavy hardware specialties in the railroad supply field. Mr. Ford is president and treasurer of the new company and is a man of long experience in the railway supply field. A native of Chicago, he entered the employ of Crerar, Adams & Company as assistant shipping clerk on June 26, 1883. He remained in that position for three years, was shipping clerk for two years, and subsequently city buyer for five years. For the past twenty-three years he has been buyer and department manager of that company.

The Commercial Acetylene Railway Light & Signal Company, having sold out its railway light and signal business to the A. G. A. Railway Light & Signal Company, will henceforth confine its efforts to the sale of acetylene, and will change its name to the Commercial Acetylene Welding Company. This policy has been adopted because of the rapid development of the welding business, as it has become apparent that the railway and welding business can be better handled by separate organizations. The officers of the Commercial Acetylene Welding Company are: E. C. Benedict, president; F. S. Hastings, vice-president; M. J. Quinn, secretary and treasurer; G. Mayer, assistant secretary and assistant treasurer. The directors include these officers and Edward Beers, Robert S. Sharp, and A. V. Conover. M. M. Smith, assistant to the general manager of the Commercial Acetylene Railway Light & Signal Company, has been promoted to the position of general manager of the Commercial Acetylene Welding Company. The office of the company is at 80 Broadway, New York.

M. M. McCallister, inspector of building shops at Schenectady and Lima for the New York Central, has been appointed boiler expert of the American Flexible Bolt Company, with headquarters at Pittsburgh, Pa. Mr. McCallister was born at Curleysville, Pa. He began his business career as the first apprentice on the Pittsburgh & Lake Erie. When he left that road he was made field erector of the James P. Witherow Company, of New Castle, Pa., manufacturers of the Heine boilers. From this position he went with the American Bridge & Iron Company in charge of the Roanoke, Va., shops, and later to the Norfolk & Western as assistant foreman of shops at Roanoke. He was next appointed assistant superintendent of the Richmond shops of the Richmond Locomotive Works, now a part of the American Locomotive Company. From here he left to become foreman boilermaker of the Lake Shore & Michigan Southern at Collinwood, Ohio. He was next appointed superintendent of the Erie City Iron Works, at Erie, Pa., leaving this position later to go as superintendent of John Brennan & Company, at Detroit, Mich., who manufacture stationary and marine boilers. He was next appointed superintendent of the Weil Boiler Company, with headquarters at Indianapolis, Ind. While here he designed and put on the market the Weil smokeless boiler, which has since proven a great success. From this position he went with the New York Central, the service of which company he now leaves to become boiler expert of the American Flexible Bolt Company.

## CATALOGUES

**LOCOMOTIVE SUPERHEATERS.**—Bulletin No. 1, recently issued by the Locomotive Superheater Company, deals with the subject of superheater header castings.

**EXPANSION JOINT.**—Catalog "A," recently issued by the Ross Heater & Manufacturing Company, Buffalo, N. Y., illustrates and describes the Ross crosshead-guided expansion joint for high and low pressure steam, oil, gas and water piping.

**AUTOMATIC FIRE DOORS.**—The Franklin Railway Supply Company has recently issued a bulletin descriptive of the Franklin No. 8 butterfly type fire door. The bulletin shows how the door is operated and tells how it affords protection for the engine crew.

**STONE TOOLS.**—The Chicago Pneumatic Tool Company has issued bulletin No. 192, which describes and illustrates the various pneumatic tools used in the cutting, surfacing and quarrying of building stones. Numerous other tools and accessories are also included.

**MEASURING COAL LOADER.**—Roberts & Schaefer Company, Chicago, have just issued a very well illustrated leaflet descriptive of their Rands measuring coal loader for locomotive. The leaflet is printed on heavy coated paper so that the illustrations show details clearly.

**GAS ENGINES.**—Bulletin No. 405 recently issued by the National Transit Pump & Machine Company, Oil City, Pa., deals with the company's types GH4A and GH4B, four-cycle, single-cylinder horizontal gas engines. These engines are supplied in 50, 75, 100 and 150 h.p.

**PIPE CUTTERS.**—The Borden Company, Warren, Ohio, has just issued a 16-page booklet concerning its die stocks and square end pipe cutters. These tools are described in detail with unusually clear illustrations, giving a comprehensive idea of their construction and operation.

**ELECTRICAL APPARATUS.**—Among recent publications of the Sprague Electric Works, New York, are Bulletin No. 49600 relating to flexible steel armored conductors, flexible steel conduit, stamped steel boxes and fittings and tools, and Bulletin No. 48907 dealing with the company's 500 lb. electric hoists, type I-5.

**TIE TAMPING OUTFIT.**—The Ingersoll-Rand Company has issued a bulletin describing the methods used and the results obtained with pneumatic tie tampers as employed on steam and electric railways. The booklet contains numerous illustrations showing how the tampers are used and illustrating the various parts of the equipment.

**WHEELBARROWS.**—The Kilbourne & Jacobs Manufacturing Company has issued a 30-page catalog No. 41 describing its line of steel and wood wheelbarrows, concrete carts, drag and wheel scrapers, dump cars and plows. Special attention is directed to the abandonment of certain designs, thus permitting greater standardization of the line.

**LOCOMOTIVE APPLIANCES.**—Bulletin No. 110, issued under date of June, 1916, by the Economy Devices Corporation, deals with the lateral motion driving box. This is designed to allow flexibility in engines with long wheel bases and to permit the employment of additional driving axles without increasing the length of the rigid wheel base.

**LOCOMOTIVE APPLIANCES.**—Two recent bulletins of the Franklin Railway Supply Company, New York, deal respectively with the Franklin automatic driving box lubricator and McLaughlin flexible conduits. Both booklets illustrate and describe the devices with which they deal, and contain information relative to their application, inspection and repair parts.

**PAINT.**—The Sherwin-Williams Company, Cleveland, O., has issued an interesting illustrated booklet of 52 pages in commemoration of the company's fiftieth year of business, compiled as a record of the important events in the company's history. It contains articles by various officers and is illustrated with photographs of the plants and officers at various periods.

**DRINKING FOUNTAINS.**—The Henry Giessel Company, 28 East Jackson boulevard, Chicago, has recently issued an illustrated booklet describing the "North Pole" sanitary drinking fountain, designed for use in passenger cars. The booklet includes a detailed explanation of the apparatus accompanied by a diagrammatic illustration, and photographs of installations on various railroads.

**ELECTRIC HOISTS.**—Bulletin No. 48906, recently issued by the Sprague Electric Works of the General Electric Company, deals with the company's type S-1 electric hoists of one-half ton and one ton capacity. The bulletin shows for what services the hoists are best adapted and gives detailed descriptions and specifications. Illustrations are shown of the cranes and of typical installations.

**OXYGEN AND HYDROGEN GENERATORS.**—Catalogue No. 3 recently issued by the International Oxygen Company, New York, deals with the I. O. C. Bipolar oxygen and hydrogen generators. The book touches upon the advantages of using the generators as against buying the oxygen or hydrogen in tanks. It also deals with the growing use of hydrogen and considerable space is given to the economy, flexibility, etc., of I. O. C. Bipolar apparatus and to the purity of the gases generated by it. The latter half of the booklet goes into detail concerning the design of the generators and the generation of the gases. The book is well illustrated and well printed.

**STEEL PIPE.**—Bulletin No. 26, issued under date of April, 1916, by the National Tube Company, is a book of 52 pages devoted to the subject of "Autogenous Welding of National Pipe." The booklet is very well illustrated, and contains extracts from a number of publications, the various articles dealing respectively with the following subjects: Welding in Gas Distribution; Gas an Important Factor at the Exposition; Welding Suburban Pressure Gas Mains; Welded Pipe Work; Oxy-acetylene Welding in Pipe Work; Efficiency of the Oxy-acetylene Welded Joint; Economies of Welded Pipe Connections, Strength of Thermit Welded Pipe; Oxy-acetylene Welding and Cutting Costs, etc. The various articles and illustrations show how the welding is done, and considerable attention is paid to the advantages of welding pipe on the one hand, and to the strength and general efficiency of National welded pipe on the other.

**CAR LIGHTING.**—Bulletin No. 154, issued under date of March, 1916, by the Electric Storage Battery Company, Philadelphia, Pa., describes in considerable detail the E. S. B. constant voltage axle lighting system. The bulletin in its 12 pages contains four parts: I, General Principles and Advantages; II, Method of Operation; III, Details of Construction, and IV, Performance Records. The fundamental principle of the E. S. B. axle system is constant voltage as distinguished from constant current. The operation of the system is fully explained in part II. The distinguishing feature is the use of the Rosenberg type of dynamo wherein the main field is produced by a magneto motive force developed by the armature winding. It is explained how, by the use of this type of dynamo, and by the use of the Wheatstone bridge method of field control, the pole changer and the lamp regulator are eliminated as are also the danger from overload and reversal of polarity. This part of the bulletin also explains why it is not necessary to have any levers, pivots, carbon piles, vibrating contacts or moving parts (except in the automatic switch) on the control panel.

# Railway Mechanical Engineer

Volume 90

August, 1916

No. 8

## The Future of the Brick Arch

Anything that compels an increase in the amount of heat absorbed by the heating surfaces in the boiler is bound to improve the efficiency of operation of the locomotive. What the railroads need is more drawbar horsepower for each pound of coal burned on the grates. The development of the brick arch during the past ten years has made it a prominent factor in attaining the present locomotive power output. It has done this by producing more complete combustion and compelling the boiler to absorb a greater proportion of the heat units liberated in the firebox. But a good many railway men seem to think that in the present development of the arch it has practically reached its limitations as regards increasing locomotive capacity. It does not seem that there will be any such limitation. There have been many devices brought out in the past which seemed at one time or another to have reached the highest point of their development but within a few years they have been subjected to changes and improvements which have resulted in still further increasing their efficiency. The brick arch is being given the constant attention of experts. It is being developed and improved whenever such improvements seem necessary or desirable and it is believed that the next few years will see still further increases in locomotive capacity and economy due to its use.

## Do Your Locomotives Suit

### Operating Conditions?

When an electrical engineer designs a motor he first familiarizes himself with the work which is expected of the completed machine. He knows the characteristics of electric motors and can determine from the curves which show these characteristics the size of the motor necessary and at what speed and output it is necessary for it to work. He would not think of putting a 90 h.p. motor on work that required only an average output of 60 h.p. It would be quite apparent that the motor would not operate at nearly its maximum efficiency under such conditions. The steam locomotive has just as well defined characteristics as the electric motor. It is quite possible to make a study of the operating conditions affecting the movement of trains on various parts of a railroad and by a careful analysis of them to determine the locomotive characteristics which will most satisfactorily and economically meet the conditions. The carrying out of such analyses preliminary to determining on a design of locomotive to give the best operating results is only a matter of common engineering sense; and yet how little the railroads seem to be following this practice in deciding on new locomotives. It is surely apparent to any railway man, whether or not he is a mechanical department man, that a locomotive which will operate the maximum time at its maximum economy is doing a great deal more toward increasing the company's net revenue than one which is developing only a portion of the power of which it is capable and working at a rate which is not that of greatest economy. Locomotives should be designed to meet the conditions under which they are to operate, just as much as

any other form of machine. The Pennsylvania Railroad has followed a policy of this kind until the resultant reduction in operating expenses is plainly in evidence in the figures shown in its annual report. There is no reason why other railways cannot improve their operating results by the application of engineering principles to determine the character of the locomotives which they need, and in most cases there is every reason why they should follow such a practice.

## Hot Boxes on Freight Cars

For years hot boxes under freight cars have proved to be one of the most troublesome problems confronting the car department. In spite of the changes in design and the greater attention which is given to lubrication and maintenance, as well as inspection, hot boxes still persist and are almost as great a problem today as they were many years ago. With the increase in severity of operating conditions, still greater efforts must be made if this difficulty is to be entirely overcome; and it is advisable that it should be, because of the great expense and inconvenience caused by delay to trains, interference with schedules, etc., in addition to the increased cost of maintenance. Many minds have been at work upon this problem and expert investigations have been made by a large number of railroads. In order to round up the ways in which hot boxes on freight cars may be overcome, we should like to hear from those who have given this subject special attention and study. To this end we offer three prizes of \$15 each for the best letters, not to exceed 750 words in length and accompanied by sketches or photographs where necessary, which are received at our offices in the Woolworth building, New York, not later than October 1. The judges will base their decision entirely upon the practical value of the suggestions which are made. Letters which are not awarded a prize, but which are published, will be paid for at our regular rates.

## Steel Gondola Cars with Wooden Sides

A substitute for the all-steel gondola car that has been found to be very satisfactory is a car that is made of steel with the exception of the floor and sides, which are built of wood. In these parts of the all-steel gondola the metal is thinner than that used in any other part of the car, and it is subjected to much more abuse and corrosion. It is practically impossible to keep the inside of these cars properly protected with paint, with the result that whether the cars are working or idle, corrosion takes place and gets in its worst work when the cars are idle. The wooden floors and sides offer many advantages. The troubles due to corrosion are eliminated and repairs can be made much more easily. A hole in a steel sheet means a riveted patch or the expensive removal and application of an entirely new sheet. Where wood is used the defective boards are easily removed and new ones applied. The wood will also stand up under shocks without deformation where the steel sheet will be bent, necessitating the use of oil torches and hammers, and sometimes presses, to bring them back into shape. By

the use of wood in these parts the strength of the car need not be diminished and the car, except in the case of hot loads, can be used in the same service as the all-steel gondola. Many roads are following this practice in replacing this class of equipment, as well as in cases where additional equipment is purchased. Their experience with this class of cars has been very satisfactory.

**Triplex  
Articulated  
Locomotives**

While the Erie Railroad is the only one that has gone into the use of the Triplex articulated compound locomotive, the officers have found the locomotive of this type which was placed in service in 1914 on Susquehanna Hill so satisfactory that two additional locomotives of the same wheel and cylinder arrangement have recently been added to the road's equipment. It is of interest to note that the changes from the original design have been very few. Practically all of the machinery and structural details are the same in the three locomotives. The principal change has been in the grate area. The original locomotive was constructed with the Gaines wall in the firebox and the need of a larger grate area prompted the omission of this wall in the new engines, increasing the grate area from 90 sq. ft. to 121.5 sq. ft., the brick arch being retained in the latest engines. The effect of this increase in grate area may be judged by a comparison of some of the ratios. There is very little change in the ratio of firebox to total heating surface, but the ratio of total (equivalent) heating surface to grate area in the original design is 102.9, while in the new engines it is 75.9, indicating either that the fuel will be burned at a considerably lower rate of combustion in the new engines, or that the same rate of combustion will be more effective in steam generation. The ratio of grate area to volume of the equivalent simple cylinders in the original engine is 1.75 and in the new ones it is 2.4. Considerable skepticism was apparent in railway circles when the first of these locomotives was built, but it is evident from the purchase of the two additional ones that the original design has amply justified itself in the eyes of the officers of the Erie.

**The Mechanical  
Department  
Supply Manufacturer**

At the beginning of 1913 this journal started the practice of grouping in a separate department the descriptions of new devices, which had been perfected and placed on the market by railway supply manufacturers. Some of our friends smiled and prophesied the early discontinuance of this section because of the lack of sufficient material to justify the use of the special heading. To be described in this section a device must have proved practical and must not have been previously described in this publication. An important improvement in an old or standard device is classed as a new device. The measuring stick applied to each device is its practical value and interest to the reader; whether the manufacturer is an advertiser, prospective advertiser or a non-advertiser is not considered. The department proved to be a success from the very start. During the past 12 months (August, 1915-July, 1916), for instance, we used 60 pages, or an average of 5 pages in each number, to describe 98 devices, classified as follows: Car, 22; locomotive, 24; shop equipment, 45; and miscellaneous, 7. In addition to this the June Daily issues of the *Railway Age Gazette*, which are furnished to subscribers of the *Railway Mechanical Engineer*, contained 32 pages in which 67 new devices were described, classified as follows: Car, 34; locomotive, 13; shop equipment, 19; and miscellaneous, 1. A new device to be described in the Daily must fulfill the conditions outlined above; it must not have been described in the *Railway Mechanical Engineer*, and it must be on exhibition at the conventions. Within a period of 12 months, therefore, we have published a total of 92 pages containing descriptions

of 165 different new devices. This truly remarkable record is a good barometer of the progressiveness of the mechanical department railway supply manufacturer.

**Standard  
Shop  
Tools**

During the past ten years the average daily wage for machinists has increased on an average of  $2\frac{1}{2}$  per cent per year, until now the total amount paid for this class of labor by the railways of this country exceeds \$60,000,000. The percentage increase for the year will be much larger than in previous years due to the demand for machinist labor by the munitions manufacturers. It behooves mechanical department officers, therefore, to devise some means by which this large and growing increase may be offset. An important item that immediately comes to mind is the increase in shop efficiency. This can be realized to a considerable degree by the standardization of shop tools. The time it takes a machinist, or any other workman for that matter, to do a piece of work depends, to a very large extent, on the efficiency of the tool with which he is doing the work.

Each tool has a certain contour, rake, clearance, size of shank, etc., that will give the best results for each class of work to be done. Dimensions for lathe tools and drills especially should be carefully determined, and such tools all over the road should be maintained according to the standards established. Where the workmen are allowed to grind their own tools there is certain to be a wide variation from the standard with an accompanying decrease in the efficiency of the tool which goes hand in hand with poor work and small shop output. After standards have once been established the only means by which they can be maintained is to have all the tools made, repaired and sharpened under the direction of one man—the tool foreman. He should be held responsible for the condition of the tools in his shop and should be given every assistance in keeping them up to standard. With his special grinders, gages and facilities for properly forming the tools, and the specialists he may have in his department, the tools can be kept in the proper form for maximum efficiency.

An interesting case where standard beading tools would have saved many leaky tubes and some engine failures was found on one road in the West. The water conditions were not of the best and it was found necessary to do a little beading on the tubes at the end of each run. The tube leakage on the engines in question got worse instead of better, and investigation showed that the boiler makers at one end of the division used a beading tool of different contour from that used at the other end. Each time the tubes were beaded the metal was wasted away, making the conditions worse every time, until the tubes had to be removed without making anywhere near their proper mileage. By establishing standards for these two terminals this trouble was overcome.

**High Capacity  
and Low  
Axle Weight**

Locomotives of the 2-10-2 type recently built for the Texas & Pacific by the Baldwin Locomotive Works are of unusual interest because of the power developed, while at the same time the driving axle loads are kept at 52,400 lb. A description of these locomotives will be published in a later issue, but a brief analysis of some of their characteristics should prove interesting. The engines have 28 in. by 32 in. cylinders, 63 in. diameter drivers, 185 lb. boiler pressure, and a total evaporative heating surface of 3,846 sq. ft., of which 307 sq. ft. is in the firebox and 3,539 sq. ft. in the tubes. At 1,000 ft. per minute piston speed they are capable of developing 2,600 indicated horsepower. Their total weight is 324,600 lb. and the weight on drivers 292,100 lb. The New York, Ontario & Western locomotives of the same type are capable of developing an indicated horsepower of 2,700 at the same piston speed, but the

have a total weight of 352,500 lb. and a weight on drivers of 293,000 lb., which is 58,600 lb. per axle. The Texas & Pacific locomotives will produce one indicated horsepower for each 12.5 lb. of total weight, while the New York, Ontario & Western engines will produce a horsepower for each 13.1 lb. The Texas & Pacific engines have to develop .676 horsepower for each square foot of evaporative heating surface while this figure in the New York, Ontario & Western engine is .601, but as the Texas & Pacific engines burn oil they undoubtedly have ample evaporative capacity.

These engines were built for operation on 70-lb. rails and in order to provide the power desired it was necessary to go to the 2-10-2 arrangement or else exceed the safe axle loads. It is also of interest to note that the Delaware & Hudson pulverized fuel burning Consolidation will produce 2,550 indicated horsepower at 1,000 ft. piston speed per minute. While, of course, in this case the weight per driving axle is high, the fact that this engine will develop one horsepower for each 11.5 lb. of total weight is an indication of what can be done in the way of boiler capacity without going to the use of a trailing truck. That the Delaware & Hudson engine has the capacity to meet this horsepower output is indicated by a comparison of the figures for the heating surface with those for the Texas & Pacific engine. The firebox heating surface in the Delaware & Hudson engine is 305 sq. ft., the tube heating surface 3,509 sq. ft. and the total evaporative heating surface 3,814 sq. ft. The weight of the Delaware & Hudson engine on drivers is 267,500 lb. and the total weight 293,000 lb., and the figure of 11.5 lb. total weight per indicated horsepower compares with a corresponding figure of 11.8 lb. for the latest 2-10-2 type engines used on the Erie Railroad, which have a total engine weight of 401,000 lb. and a weight on drivers of 335,500 lb.

**Mechanical Conventions in August and September**

The Master Mechanics' Association as a body has recognized the importance of the "other" railway mechanical associations by the formation of a committee to co-operate with these associations, and at the June convention this committee presented a report in which was included contributions from the Association of Railway Electrical Engineers, the Traveling Engineers' Association, the General Foremen's Association and the Tool Foremen's Association. The last three mentioned associations, together with the Master Blacksmiths' Association, will meet within the next few weeks, and it is strongly urged that the mechanical department officers give their earnest consideration to the matter of sending to these conventions their foremen who are directly interested in work of the respective associations. All four of these associations are well established organizations, and, as past results have shown, contribute materially to economical shop production.

There are three important reasons why these men should attend the conventions in which they are particularly interested. Perhaps the most important one is the broadening of their knowledge by the important ideas picked up in their informal talks with fellow craftsmen on problems that they are perhaps having difficulty in solving. The next is the information they receive in listening to the results of a committee's work on a certain subject and the discussion which follows. Here is where they can perform a dual service—absorb all the information they can from fellow members and give those same members the benefit of their personal experience. It is only by such reciprocity that the most can be learned from any subject discussed.

The supply men's exhibit is also of great importance. It is well known that most of the economies effected in locomotive or shop operation are the results of the machines or devices sold or controlled by the railway supply firms. These companies, specialists in their respective lines, spend large sums of money in studying and developing their products

and come to these conventions well prepared to show the railway men on the firing line just what their devices will do. With their apparatus set up in the exhibition hall they can explain clearly the details of the various devices, show the men what they are expected to do, how it is done and how they should be maintained in order that the best results may be obtained from their use. It is important that these men should know all about these new devices. Take the traveling engineer, for instance; he is called upon to instruct the men regarding the use of more different devices and make reports to his superior officer regarding them than perhaps any other man on the railroad. If he is to do this intelligently he must see the devices in the form of models and be thoroughly posted on their operation and special features. It is much more satisfactory both to him and the manufacturer to have these devices explained from working models cut open or taken apart for the purpose, than from the finished devices which are perhaps located on some inaccessible part of the locomotive. The shop foremen can be shown how to get the most work out of the tools they may have, or they may find a new device that will prove to be of decided advantage in their particular line. The exhibits are an important part of any convention, and the supply men's associations aim to make them complete and educational in nature. Last year there were 72 exhibitors at the Traveling Engineers' convention, 40 at the General Foremen's convention and 32 at the Tool Foremen's convention. This year it is confidently expected that there will be an increase in these numbers.

The lists of subjects to be discussed at these conventions have been published in the *Railway Mechanical Engineer* and are again included in this number; it will be noticed that they are all of importance in the fields of the respective associations. New problems are constantly arising in the railway mechanical department, and these associations have done much to overcome them. The men should be sent to the conventions to give and receive all the information possible. On some roads it is the practice for the men attending to submit written reports to their superiors of the important things learned from both the discussions of the committee reports in the convention hall and from a study of the exhibits shown in connection with the convention. This is a splendid plan to follow, for it not only firmly fixes the benefits obtained from the convention in their own minds, but also gives the men at home the benefit of the attendant's experience.

**NEW BOOKS**

*National Association of Corporation Schools.* Report of the third annual convention. Bound in cloth, 880 pages, 6 in. by 9 in. Published by the Association, Irving Place and 15th street, New York.

This volume contains the papers, reports, bibliographies and discussions of the third annual convention, held in Worcester, Mass., June 11, 1915. A number of charts are used and the subjects considered include public education, trade apprenticeship schools, vocational guidance, special apprenticeship schools and satisfactory hygiene and co-operation.

*Inventions and Patents.* By Philip E. Edelman. Bound in cloth, 279 pages (including an appendix), 5 in. by 8 in. Illustrated. Published by D. Van Nostrand Company, 25 Park Place, New York. Price \$1.50.

This volume is intended for all persons who are interested in patents either as inventors, investigators or manufacturers. There seems to be a general ignorance among such men of the points involved in patent procedure and the possibilities in patented inventions. The subject is explained in this book in every-day terms. The matter is intended to be suggestive and there are no set rules to be applied in every case. The book is not intended to be exhaustive, as the author considers the subject too comprehensive to allow of such treatment. The information given will be found reasonably complete and all that is necessary in most cases. The viewpoint is optimistic throughout and considers the interests of all concerned.

## COMMUNICATIONS

### OXY-ACETYLENE CYLINDER WELD

KANSAS CITY, Mo.

TO THE EDITOR:

Since the publication of the article on "A Record Cylinder Weld" in the *Railway Mechanical Engineer* for April, page 199, Mr. Foster, master mechanic of the St. Louis & San Francisco at Kansas City, who sent you the information, has received a number of inquiries as to the methods followed in making this weld, the kind of flux used, whether or not the weld was easily machined and numerous others. As this cylinder is similar to three others recently repaired, as the same general method was followed, and as the finished jobs were excellent, I believe we can perhaps assist others who are contemplating cylinder welding by going into more detail on this particular job.

The most essential part in work of this kind is to have two welding operators who have had thorough experience on welding cast iron and other metals by the oxy-acetylene method and who can be relied upon to follow instructions closely even to the smallest item, which sometimes may be the most important. For work of this character acetylene operators, no matter how proficient they may be, who have

brought to a red heat. They were then welded along the lines marked "X" in Fig. 1. The welded segment was then covered with sheet iron or asbestos with a charcoal filling and allowed to cool slowly. It is very important not to allow cold blasts to blow on the metal while it is hot. When it was cool it was fitted to the cylinder and the cracks to be welded were chipped out from the inside. No chipping was done on the segment except at the extreme point of the break, which was done to give the operators a better opportunity to make the weld and to prevent the metal flowing off. After clamping the segment in place a temporary furnace was constructed by placing pieces of coarse netting, about 4 ft. by 5 ft., on top of spring bands or blocks about 7 in. from the floor. The cylinder was then surrounded by a sheet iron or heavy tin shell, as shown in Fig. 3, the different pieces being wired together to completely enclose the cylinder. A slit was cut in the outside wall and bent out to form a hopper through which was fed the charcoal for heating the lower part of the cylinder. A coal oil torch was used to heat the heavy parts of the cylinder on the top and side next to the frame. The cylinder was heated gradually and care was taken not to suddenly heat one part of the cylinder while the rest was cold. When the cylinder was at a red heat two operators, one on each end, started welding while a laborer watched the fire and also kept all doors closed through which there might be a draft blowing on the cylinder. After the welding had been completed on the inside the ends or flanges were welded from the outside and the corners were built up. A piece of wire screen was then placed at E in the cylinder a little below the center, on which hot charcoal was placed. It was then filled with more charcoal and both ends of the cylinder were securely closed with sheet iron, the fire allowed to burn out and the cylinder was left to cool slowly. The metal on this cylinder was  $2\frac{1}{8}$  in. thick, while on other engines on which similar work was done the thickness was  $1\frac{5}{8}$  in. and  $\frac{7}{8}$  in. In the case of the latter, however, it was necessary to put a bushing in the cylinder.

M. C. WHELAN,

Foreman Blacksmith, St. Louis & San Francisco.

### GREASE LUBRICATION OF LOCOMOTIVE DRIVING BOXES

BALTIMORE, Md.

TO THE EDITOR:

I have read with much interest the article by George J. Burns, on "Grease Lubrication of Locomotive Driving Boxes," in the May number of the *Railway Mechanical Engineer*, page 234. Careful reading of this will show that facts are presented, which, if given a trial, will prove that the author has based the statement on results that have already been obtained. The matter of lubrication of driving boxes is of vital importance, as the result of many failures can be directly attributed to a lack of it which often requires the locomotive to be taken out of service, new crown bearings applied, journals trued off and sometimes new axles applied. This, together with the drop pit work needed to remove the wheels and other work entailed, such as removing rods, etc., suggests how important a factor in reducing the cost of upkeep of a locomotive the suggestions given by Mr. Burns would prove, if put into practice. In too many cases it has been only too well proved that there is an obsession resulting from a long observance of usual practices. In railroad work, as well as in any other progressive work, the customs and practices of yesterday must be laid aside for improved practices of today and tomorrow. The narrow view that a practice, having been employed for 20 years, is the best practice simply because it has served the purpose, does not imply that other ideas cannot be employed, other methods put into effect and other systems inaugurated that will revolutionize the several old methods and produce far better results.

JOHN V. LE COMPTE.

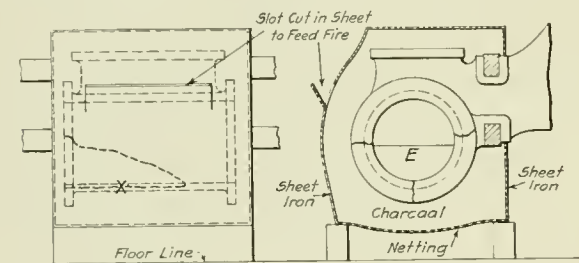

Fig. 3.

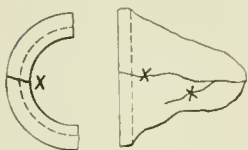

Fig. 1

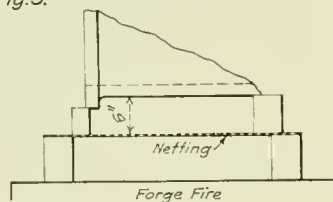

Fig. 2.

Oxy-Acetylene Cylinder Weld. Fig. 1—Broken Parts of the Cylinder Welded Before Placing on the Engine; Fig. 2—Manner of Placing the Parts (Fig. 1) on the Forge Fire; Fig. 3—Method of Heating the Entire Cylinder Preparatory to Welding

not been accustomed to perform tasks when extreme heat is encountered should not be selected or failure will result. With operators who are accustomed to heat, work of this kind is not laborious nor unpleasant. While no two jobs of this kind are exactly alike, it being necessary to prepare and handle them differently so as to make it more convenient for the operators and to prevent checks in the finished job, the same rules will apply generally. The expansion and contraction of the metals, a clear understanding as to the shape of the article welded and the proper part to heat first and last to prevent failure, should be thoroughly fixed in the minds of the operators before beginning. The kind of flux used is not of so much importance as the proper amount to be used and the manner of applying it. This applies also to the use of a welding flux at the forge. In either case it requires some little experience. On this weld Ferro flux was used and the cylinder was bored with as much ease as any ordinary cast iron.

Fig. 1 shows the parts that were taken to the smithshop. The surfaces to be welded were V'd out by chipping and the parts clamped together at the proper radius. They were then placed on blocks above a forge fire, as shown in Fig. 2, and

# BALTIMORE & OHIO ROAD MALLETS

New 2-8-8-0 Type Locomotives Replace Simple 2-10-2 Type Engines on Grades Over Two Per Cent



Baltimore & Ohio Mallet Type Locomotive

THE Baltimore & Ohio has recently received from the Baldwin Locomotive Works 15 Mallet articulated locomotives of the 2-8-8-0 type. These engines exert a tractive effort of 103,000 lb., and are used in road service on the Cumberland division, replacing single expansion locomotives of the 2-10-2 type, which have been transferred to a section of the road having lighter grades. The maximum grades on the Cumberland division are 2.4 per cent east bound and 2.28 per cent west bound. The traffic is very heavy, consisting chiefly of coal, and on few roads in this country are more difficult operating conditions to be found.

The boilers of the new Mallets are of the conical type, the

ing surface of 263 sq. ft. Both engines are equipped with Schmidt superheaters, the Mallets having 86 sq. ft. more superheating surface than the others. The grates and the arrangement of the cab fittings are practically alike in both engines, and both are fired by Street stokers.

The combustion chamber is 60 in. long, and the front end of the combustion chamber crown is supported on three rows of Baldwin expansion stays. There is a complete installation of flexible stays in the water-legs. The middle seam in the barrel, and the seams uniting the throat and outside firebox shell with the fourth ring are triple riveted. Some of the combustion chamber stays are necessarily tapped into the throat

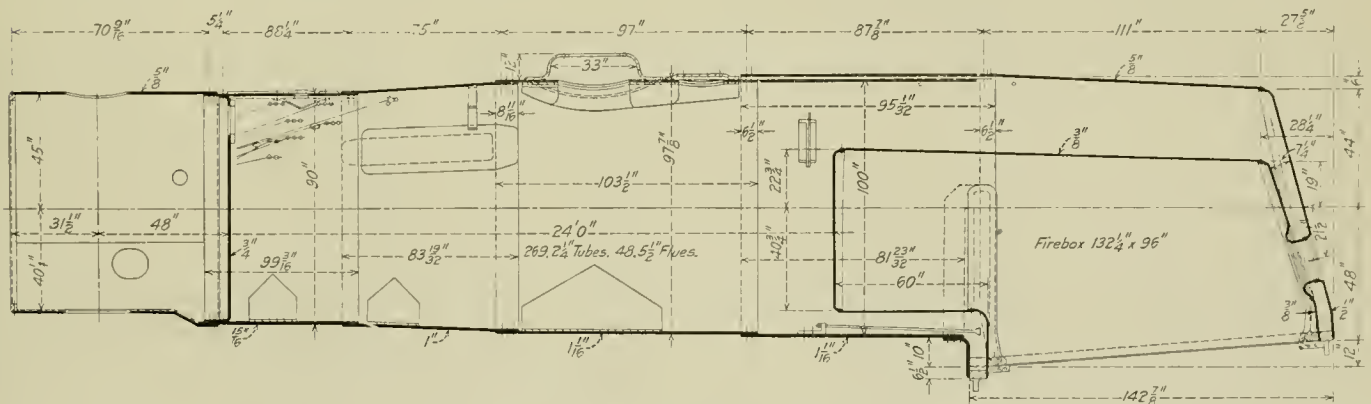

Boiler for the Baltimore & Ohio Mallet Type

second ring in the barrel being tapered, increasing the shell diameter from 90 in. at the first ring to 100 in. at the throat. As far as front end diameter, number of tubes and principal firebox dimensions are concerned, the boilers of the Mallets are similar to those of the 2-10-2 engines previously referred to.\* The length of the tubes, however, is 24 ft., as compared with 23 ft. in the 2-10-2 type, and the combustion chamber is 32 in. longer. This accounts for an increase in total heat-

and outside shell seams and where this occurs the stays are so located as to replace rivets in the center row. The Security brick arch, in the Mallet type, is supported on five 3-in. tubes. These extend from the bottom of the combustion chamber to the back sheet of the firebox. This arrangement of tubes improves the circulation in the horizontal water space under the combustion chamber, and as the arch tubes are comparatively long they add considerably to the firebox heating surface.

The shell plates of the boiler are heavy, those constituting

\*For a description of these locomotives see the *Railway Age Gazette*, Mechanical Edition, for September, 1914, page 456.







Wheels, diameter .....	33 in.
Journals, diameter and length .....	6 in. by 11 in.
Water capacity .....	12,000 gal.
Coal capacity .....	20 tons

## LOCOMOTIVE FIREBOX PROPORTIONS

BY LAWFORD H. FRY

In discussing the report of the Committee on Fuel Economy at the Master Mechanics' Association convention in 1915, the writer called attention to the necessity for sufficient firebox volume, and pointed out that the volume provided could be conveniently measured by the ratio of firebox heating surface to grate area. The present article is intended to discuss further the question of firebox volume and this proposed method of measuring it, and at the same time to deal with an objection which has been made.

Let us take first the question of firebox volume, and consider what happens during combustion, not so much the chemical but the mechanical action taking place. Air and coal are brought together for combustion. The air, by reason of the draft created by the blast pipe, is sucked in through the grate openings and firedoor, and swept through the firebox into the tubes and out through the smokebox. The coal, on being thrown into the firebox, is rapidly split up by the heat into fixed carbon and volatile matter. The fixed carbon lies on the grate and burns there with part of the air entering through the grate, while the volatile matter, which carries a very considerable proportion of the heating value of soft coal, is swept through the firebox with the remainder of the air and the smaller particles of coal carried off the grate by the draft. The volatile matter and the small particles of coal will be burned if they have an opportunity of coming into contact with the oxygen of the air while at the high temperature of the firebox. When the gases enter the tubes the temperature falls too low for combustion to continue. Consequently the completeness with which soft coal is burned will largely depend on the time and opportunity afforded to the gases for mixing in the firebox. A brick arch will greatly assist the mixing of the gases at high temperature, but firebox volume is of high importance. In practically any locomotive boiler an increase in firebox volume would mean an increase in opportunity for more complete combustion and consequently an increase in efficiency.

Now, in a locomotive firebox of a given grate area, an increase in firebox heating surface means an increase in firebox volume, and we may therefore say with quite sufficient accuracy that an increase in the ratio of firebox heating surface to grate area means an increase in the ratio of firebox volume to grate area; or going back to the previous proposition, we can say that an increase in the ratio of firebox heating surface to grate area means an increase in the efficiency of combustion.

This is undoubtedly true, but the superintendent of motive power of a large western road has pointed out to the writer that a high ratio of firebox heating surface to grate area does not necessarily indicate a desirable locomotive, and that it may, in fact, be accompanied by conditions which give undue difficulty in firebox maintenance. The point is illustrated by the four locomotives, the dimensions of which are given in Tables I and II. The locomotives of the three classes *A*, *C* and *D*, with respectively 4.45, 3.40 and 3.39 sq. ft. of firebox heating surface per square foot of grate area, are very satisfactory while the class *B* locomotives, with 5.28 sq. ft. of firebox surface per square foot of grate, give an undue amount of operating trouble from leaky staybolts.

An instructive lesson in locomotive proportions and in the use of ratios for comparing locomotives can be drawn from a consideration of this statement. In the first place we have our attention called to the fact that a single ratio is never

sufficient for a criticism of a locomotive, the reason for this being that the value of the ratio may be increased by increasing one of the quantities compared or by reducing the other. For example, in a given design we can increase the figure for the firebox heating surface per square foot of grate area, either by increasing the firebox surface or by reducing the grate area. Therefore a high ratio may mean either ample firebox surface (which would give ample firebox volume), or it may mean a restricted grate area. Our conclusion that an increase in the ratio of firebox surface to grate area gives an increase in efficiency is based on a comparison in which the rate of combustion per square foot of grate area is the same. If the boiler with the larger volume ratio has to be forced to a higher rate of combustion per square foot of grate, all the efficiency gained by the greater volume may be lost, and further drawbacks may be introduced. As we shall see, this happens in the case of the class *B* locomotives. To study this side of the question we need some measure for the relation between the size of the grate and the service for which the locomotive is intended, and for this purpose the rated tractive effort per square foot of grate area is suggested. The values of this for the four locomotives referred to above are shown in Table II. The rated tractive effort is calculated by the usual formula from the cylinder and driving wheel dimensions, using 85 per cent of the boiler pressure as mean effective, and the table shows in column 7 the rated tractive effort per square foot of total heating surface and in column 8 the rated tractive effort per square foot of grate area. It will be seen that while classes *A*, *C* and *D* have from 808 to 860 lb. of tractive effort per square foot of grate, class *B* requires each square foot of grate to furnish no less than 1,005 lb. of tractive effort. This means that to develop the same proportion of total power the class *B* locomotives must have the combustion per square foot of grate forced from 20 to 25 per cent harder than the other classes. Herein lies the cause of the firebox and staybolt trouble with this class. The forcing of the fire means an excessively high firebox temperature which is detrimental to the life of the box, both by its direct action and by reason of the great drop in temperature produced when the engine is shut off.

It is interesting to compare also the figures for tractive effort per square foot of total heating surface. On this basis of comparison the class *B* engine makes the best showing, having only 11.2 lb. per square foot, while class *D* has 11.8, class *C*, 14.8 and class *A*, 17.0 lb. of tractive effort per square foot of grate. These figures show that if the four locomotives are loaded in proportion to the cylinder dimensions, class *B* will of all four engines make the greatest demand on the grate and the least on the evaporative power of the heating surface. And if the matter be put the other way about and the loads of the four engines be proportioned to the dimensions of the grates, class *B* will make a very favorable showing so far as efficiency of steam production is concerned, as both the large proportion of firebox surface per square foot of grate and the large proportion of total heating surface per square foot of grate make for boiler efficiency. As a whole, however, our conclusion will be that the class *B* engine could be improved by an increase in the area of the grate, the other dimensions remaining as they now are.

Returning now to general principles we can say that a high ratio of firebox heating surface to grate area is desirable when it is obtained by giving ample firebox surface and undesirable when obtained by a restricted grate area. A usual figure in large modern locomotives is 3.5 sq. ft. of firebox to each square foot of grate area. It would be better to have 4.0 sq. ft., and 4.5 sq. ft. can be obtained in some cases and should be aimed at where practical. It will usually be found impossible to do better than this if the grate area is full size. As a general indication of modern practice in the

proportions of grate area to tractive effort the following figures are given:

Type of locomotive	Rated tractive effort in lb. per sq. ft. of grate area
4-4-2 } Saturated .....	500
} Superheated .....	600
4-6-2 } Saturated .....	550
} Superheated .....	650
2-8-0 } Saturated .....	825
} Superheated .....	925
2-8-2 } Saturated .....	775
} Superheated .....	875

These figures are for soft coal burning locomotives, and the aim should be not to exceed them, or, in other words, to provide as much grate area as is practicable.

TABLE I—PROPORTIONS OF HEATING SURFACES AND GRATE AREA

Class	1 Firebox heating surface, sq. ft.	2 Total heating surface, sq. ft.	3 Grate area, sq. ft.	4 Sq. ft. of total heating surface per sq. ft. of grate area	5 Sq. ft. of firebox heating surface per sq. ft. of grate area
A .....	140	1,498	31.5	47.6	4.45
B .....	161	2,814	30.8	91.4	5.28
C .....	167	2,844	49.0	58.0	3.40
D .....	187	3,830	55.1	69.6	3.39

TABLE II—TRACTION EFFORT FACTORS

Class	Cylinder		4 Driving wheel diam., in.	5 Boiler pressure, lb. per sq. in.	6 Rated tractive effort, lb.	7 Lb. tractive effort per sq. ft. total heating surface	8 Lb. tractive effort per sq. ft. of grate area
	2 Diam., in.	3 Stroke, in.					
A .....	20	24	53	150	25,400	17.0	808
B .....	20	28	62	205	31,400	11.2	1,005
C .....	22	28	56	205	42,000	14.8	860
D .....	24	28	62	205	45,300	11.8	825

### WATER TREATMENT ON THE MISSOURI PACIFIC

During 1915, 604,470,000 gal. of water were treated by softening plants on the Missouri Pacific, removing from this water 1,816,837 lb. of scale-forming solids. There are 33 water-treating plants in operation on the main and branch lines between St. Louis, Mo., and Pueblo, Colo., which have been in service from 5 to 10 years, and represent a total investment of \$70,450. On the basis of a saving of 7 cents per pound for incrusting matter kept from entering the engine boilers, as outlined by the water service committee of the American Railway Engineering Association in 1914, the total saving to the railway from the removal of this scaling

an intangible nature. However, values were placed on four of them—loss of fuel resulting from the insulating effect of the scale, renewal of tubes, repair work on tubes and boilers in the roundhouse, and the loss of engine time during repairs. On account of its intangible nature and the difference in the relation on the various districts, the reduction of engine failures was not considered in determining the above figure. It has been found that the average cost per engine failure, exclusive of labor and material for repairs, amounts to \$17, and on one division the engine failures resulting from boiler troubles were cut down over 1,000 per year by the treatment of the water, thereby giving a saving in this one item alone of \$17,000. From this it is seen that 7 cents is very conservative.

The accompanying table shows the character and source of supply, the amount of water treated, the amount of incrustants removed, the cost of plant, and the cost of operation of the 33 plants during the year 1915. The amount of scale removed was derived by checking the raw water hardness against the incrusting solids still remaining in the water after treatment.

Of the 33 plants on the Missouri Pacific, 16 are of the intermittent, and 17 of the continuous type, of various designs. The majority were installed by company forces under the supervision of the superintendent of water service, and each one was designed to fit the individual station with a view to providing for the maximum use of the existing facilities. Material changes have been necessary in some of the first plants installed, but all have paid for themselves many times over, and after several years of service are still yielding 142.5 per cent on the investment.

Many of the stations were equipped for softening the water at a remarkably small expense. Intermittent plants were provided by placing a second tank beside the old one and equipping each with air-agitating pipes, each serving alternately as a storage and a treating tank. Where penstocks are used, the pumper manipulates the valves into the discharge line so that the proper tank is connected at all times. Where engines take water direct from the tank, each one is equipped with a spout, the operator placing a white flag on the tank from which water is to be taken.

The most inexpensive plant is built inside a roadside tank and consists of a shallow box placed under the roof



Scale from Untreated Water

material amounted to \$127,171. From this must be deducted \$26,717 for the cost of treatment, including additional labor, chemicals, maintenance and 10 per cent to cover interest and depreciation in the treating facilities, leaving a net saving of \$100,454.

In arriving at the figure of 7 cents per pound for incrusting matter removed, the committee realized that the benefits derived from water treatment are numerous, but usually of

of the tank to act as a mixing basin for the chemicals and water. The mixture then flows down through a large discharge pipe to the bottom of a small inside tank about 10 or 12 ft. in diameter, from which it is discharged at the top through an 18-in. excelsior filter into the tank proper, which serves as a storage compartment. At small stations where the rate of pumping does not exceed 4,000 or 5,000 gal. per hour, this plant has proved very successful and economical.

but where the rate of upward flow of the water requires it to pass the filter in less than three hours, there is a strong tendency for the sludge to be carried over, resulting in milky water, which induces foaming. The chemicals are put in with a small simple displacement plunger pump and the mixture is regulated by the chemist's instructions of so many inches from the chemical vat per foot of water in the tank.

A continuous plant for larger capacities has given very good service. In this case the chemicals and water mix in a small box at the top of the tank, and because of the large volume of water going through a small space very thorough agitation is secured. The mixture then goes down through an inside steel tube 6 ft. in diameter, which quiets all eddies, and comes up in an outside storage tank with no filter. By proper treatment of the water a good, clear effluent is obtained at the height of 18 ft. in a tank 30 ft. in diameter, pumping at the rate of 25,000 gal. per hour. The amount

ports. For many points where a softening plant will be located eventually on account of the hardness of the water, the scaling effect is overcome to a large extent by overtreatment at the nearest adjacent treating plant. Tests of the water taken from engine boilers on the various districts are frequently made and the treatment is adjusted as far as possible to give an excess of caustic alkalinity from sodium hydrate in the boilers at all times. Where it has been impossible to do this with the present treating facilities, excellent success has been obtained by the introduction of soda ash direct into the engine boilers through the washout holes after each washout, in amounts determined by the chemist. On account of the large amount of sludge and mud formed in the boilers, foaming conditions result, but this has been kept at a minimum and no serious trouble has been experienced. An anti-foaming compound prepared by the company's chemist is used to take care of this feature. Before soda ash was used in this manner the engine failures on one division from boiler troubles were 19.1 per 100,000 engine miles, but they were reduced to 9.1 in 1915, when the soda ash treatment was in effect. Only five failures due to foaming occurred during the same year, a lack of compound being responsible for three of the five. Records show that continuous improvement is being made with the increased familiarity in handling.

From the figures shown it is not difficult to determine the

Station	Source of Supply	Raw Water Hardness in Grains Per Gal.	Annual Consumption In Gallons	Pounds of Scale Removed	Original Cost of Treating Facilities	Total Additional Cost for Treatment	Total Saving
Auburn, Neb.	Well	30	26,667,980	85,330	\$ 7,500	\$ 2,156	\$ 5,344
Berlin, Neb.	Well	28	3,170,400	10,463	1,500	243	737
Brownell, Kan.	Well	12.5	15,990,000	23,965	750	296	1,679
Buehton, Kan.	Well	16.0	11,640,755	20,370	750	234	1,426
Caney, Kan.	Creek	12 - 28	3,648,000	7,276	1,500	424	509
Cedarvale, Kan.	Creek	12 - 18	3,316,500	4,975	750	295	348
Concordia, Kan.	Well	35.0	10,164,300	40,738	2,300	545	2,652
Downs, Kan.	Well	16.0	11,137,000	16,707	6,500	824	1,170
Eads, Colo.	Well	23.0	8,470,000	15,245	2,000	365	1,067
Greenleaf, Kan.	Well	24 - 40	10,593,387	37,076	3,000	601	2,595
Gypsum City, Kan.	Creek	12 - 40	12,194,000	35,582	3,000	686	2,566
Haskell, Colo.	Well	27.0	13,270,000	46,445	2,000	550	3,251
Herrington, Kan.	Creek	20 - 65	8,149,000	40,745	3,000	682	2,852
Holeington, Kan.	Well	16 - 18	61,940,000	123,860	5,000	1,235	8,672
Solton, Kan.	Well	35.0	3,318,030	14,931	2,000	448	1,045
Jamestown, Kan.	Well	16 - 22	7,245,220	14,490	750	145	1,014
La Platte, Neb.	Creek	10 - 19	13,655,000	31,406	750	207	2,198
Le Roy, Kan.	Creek	10 - 20	18,027,000	27,040	3,000	520	1,693
Lenora, Kan.	Well	20.0	2,746,000	5,492	350	102	364
Marquette, Kan.	Well	18 - 30	21,591,450	54,744	750	557	4,532
Oak Mills, Kan.	Well	27.5	5,977,500	13,150	1,500	393	921
Oloott, Kan.	Well	16.0	1,963,000	3,926	800	153	275
Ordway, Colo.	Reservoir	25 - 15	18,167,000	90,836	3,000	1,215	6,356
Pueblo, Colo.	Well	18 - 30	31,800,000	95,400	2,500	942	6,578
Roper, Kan.	Creek	10 - 16	9,490,800	14,235	500	227	996
Scott City, Kan.	Well	11.5	19,856,000	19,856	2,000	580	1,390
Sedalia, Mo.	Well	18.0	18,250,300	35,500	1,500	234	2,555
Seneca, Kan.	Well	22.0	6,098,800	13,257	2,000	409	928
Union, Neb.	Creek	6 - 18	21,405,000	21,405	2,000	600	1,498
Weeping Water, Neb.	Creek	6 - 18	8,375,400	8,376	2,000	374	585
Wichita, Kan.	Well	50.0	65,158,000	330,790	750	3,237	23,155
Wintfield, Min.	Creek	12 - 25	4,501,500	9,002	1,500	397	630
Kansas City, Mo.	Well City water	35.0 8 - 22	127,310,000	492,105	10,000	5,421	34,447
TOTALS			604,468,087	1,816,837	\$70,450	\$26,717	\$127,171

Conditions at the Treating Plants

of chemicals is regulated and supplied by a small plunger pump, as in the other style of plant.

The water-treating plants are operated by pumpmen under the supervision of the division water service foreman. The treatment is regulated by a chemist stationed at Kansas City, the most central location. Samples of both the raw and treated water are sent to him from each plant twice a week. Formulas are changed and any failures are investigated by him, and he is directly responsible for the results secured. Any corrections or changes found necessary are made by the division forces. Reports of the semi-weekly tests are furnished the general and division offices. A content of not more than six grains of incrusting solids per gallon in the treated water has been made a standard and any failure to meet this requires an explanation.

The treatment in general is gaged by the direct effect on the locomotive boilers. During his inspection trips the chemist consults the master mechanic, foremen and head boilermakers at the engine terminals as to the results obtained and checks failures due to leaking through daily re-



Scale, Less Than 1/16 In. Thick, from Treated Water

advantages secured. The life of tubes has been increased from 50 to 300 per cent. Engine failures on one division have been decreased from 1,435 in 1910 to 202 in 1915, resulting almost entirely from the decrease in boiler failures in consequence of the use of soda ash and treated water. On the same division the boilermaker force has been reduced from 17 to 7 at the terminal roundhouse, a saving of \$15,000 per year in this item alone.

At the Sedalia, Mo., power plant, where the water is treated for five Babcock & Wilcox double-deck water tube boilers of 275 hp. each, 715 of the 840 four-inch tubes have been in continuous service for the past eleven years on treated water. On account of the shortage of boiler capacity and the unavoidable heavy duty, there has been insufficient time to shut down these boilers for washing out and two of them ran for five years between washouts, at the end of which time the scale on the tubes was less than 1-16 in. thick. With raw water, tube failures were frequent and scale heavy.

The photographs show some samples of boiler scale, illustrating the difference between treated and untreated water. The one at the left in the larger photograph shows a piece of scale 1 1/2 in. thick, taken from a front tube sheet after 10 months' service. The one in the center shows a sample of sulphate scale 1/4 in. thick, which put a boiler out of commission after three months' service. The one at the right shows a specimen of scale entirely clogging up the space between boiler tubes after eight months' service. The other photograph shows small fragments taken from locomotive boiler tubes after two years' service on the same district after the installation of treating plants and use of treated water.

# AN EIGHT-WHEEL ENGLISH LOCOMOTIVE

Engines of This Type, With Superheaters, Hauling Fast Passenger Trains on the Great Central

THE 4-4-0 type locomotive is at the present time performing some of the heaviest and fastest express passenger work on British railways. The loading of the trains is in many cases exceedingly heavy, and even with the tendency towards lower rates of speed as now practiced on some lines the average speeds rule high, and are consecutively maintained for runs of long duration without intermediate stops.

The 4-4-0 type locomotive is economical to build, while its maintenance costs are somewhat lower than those of locomotives having more extended wheel arrangements. As compared with the 4-4-2 type the 4-4-0, built in accordance with the most modern standards, is capable of doing equal work, and on the majority of railways the latter class may be said to have outlived the popularity and usefulness of the Atlantic

and although the benefits conferred by superheating are by no means restricted to any one class of locomotive its influence is perhaps more appreciably felt with the 4-4-0 type than with other and heavier locomotives.

The design of a 4-4-0 type locomotive in accordance with the ideas prevailing in England is based on simple and straightforward principles. The majority of such engines are equipped with inside cylinders to which superheated steam is distributed by means of piston valves actuated by one or other of the more simple forms of valve motion. There is an entire absence of complication of detail and frictional losses are thereby reduced to a considerable extent, so that the engine develops its power under the most favorable circumstances and the tractive effort it exerts is available for the purpose of dealing with heavy paying loads in-

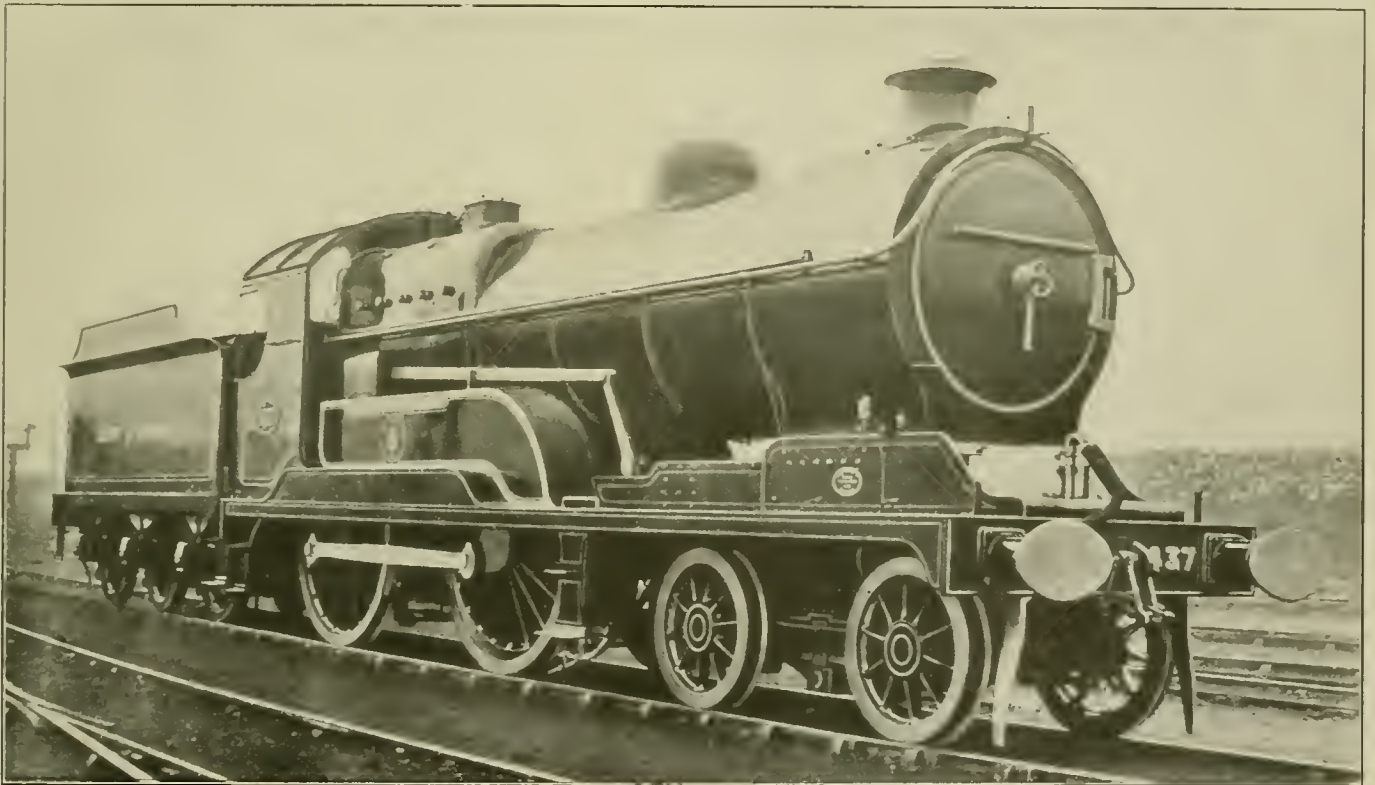

Locomotive of the 4-4-0 Type for Fast Passenger Service on the Great Central Railway of England

type, which at one time appeared likely to supersede the 4-4-0 type for the most important and fastest passenger traffic.

The advent of the superheater has perhaps been responsible, as much as, if not more than anything else, for the retention of the 4-4-0 type locomotive in the front rank. The use of superheated steam in large cylinders and in conjunction with a boiler designed with ample heating surface and a sufficient capacity has resulted in largely increasing the scope of a locomotive planned on the 4-4-0 wheel arrangement, and although the type has receded in other countries its position seems to be assured on British railways for some time to come where the principal main line passenger service is concerned. Without the superheater it is hardly possible that this type of locomotive would have continued to figure so prominently in present-day British locomotive practice,

stead of a disproportionate amount of power being absorbed by moving the locomotive itself.

As an example of a modern design of the 4-4-0 type locomotive in England, there is illustrated herewith an engine of the "Director" class introduced on the Great Central Railway by the chief mechanical engineer, John G. Robinson. These engines have proved successful in every way in hauling the fastest and heaviest trains on that road. They are economical in fuel consumption, and as test runs have shown are capable of reaching very high speeds with heavy train loads. In these engines it was sought to combine the necessary features for the development of a high power capacity while retaining a general construction which is simple. The cylinders are placed between the frames at a distance of 2 ft. 0 $\frac{1}{2}$  in. between centers. Superheated steam is distributed to the cylinders by outside admission piston valves 10 in. in



diameter which work above the cylinders. The cylinders are fitted with the Robinson pressure release valve, the two valves at each end of the cylinder being combined in a single casting; that is to say, there are two such castings, each containing two valves which communicate by means of a perforated connecting pipe. These pressure release valves combine the functions of air valves, water relief valves and compression release valves when running without steam.

The valve spindle packing, which is exposed to the superheated steam, is composed of a special bronze instead of the usual lead and antimony white metal. The piston rod packing which, owing to the expansion of the steam in the cylinder, is always at a much lower temperature, is of the usual lead-antimony mixture. The packings are of the standard type as used on non-superheater locomotives, as it is found that no need exists for special packing even when using superheated steam of over 700 deg. F. in the steam chest. It is found, however, that when the steam chests are above the

contains a Robinson superheater of 24 elements. These elements are of the short return type in order to permit as large a flow of hot gases through the large tubes as possible. It has been found that any greater return length than about half that of the tubes results in a loss of superheat and to such an extent that it more than counterbalances the small gain in evaporative efficiency that results when the elements are returned the full length of the tube. There are no superheater dampers in this design. A small quantity of steam from the boiler, controlled by the same valve that operates the blower, is circulated through the superheater when steam is shut off. This prevents the oil delivered by the mechanical lubricator from accumulating and so causing carbonaceous deposits to form on the walls of the steam chest and on the ports, valves and pistons. A double beat valve, connected by a tappet and rods to the regulator handle, is so arranged as to open as soon as the throttle is closed, and to close just as the throttle opens. This serves to prevent any possibility of the circulating steam accumulating in the steam chest and so starting the engine should the valve controlling it be left open after the engine stops. As this circulation is not needed when the engine, and therefore the mechanical lubrication, has stopped, the circulating and blower valve is so made that it can be turned to a position to supply the blower only when standing and, of course, to shut off both when required.

The 2-in. pipe by which the double seated valve empties the header and steam pipe connects with the base of the exhaust pipe, thus discharging through the stack to the atmosphere, by which means the noise of the exhaust is much softened.

The "Director" class locomotives at present consume just under 39 lb. of coal per mile, which is but little more than the compound superheater engines of the Great Central Railway, which have the 4-4-2 wheel arrangement, and much less than the saturated steam heavy express engines on the same line. The normal train loadings on the Great Central are not, where passenger traffic is concerned, as heavy as those on certain other railways, but the grades are such as to make difficult work for the engines, especially in view of the high speed of the more important trains. The average grading of the line south of Leicester is 1 in 176. The "Director" class locomotives have not as yet been indicated or tested with a dynamometer car, but there is no doubt that they can maintain over 1,000 indicated horse-power and can be made to develop over 1,200 indicated horse-power, considering them in comparison with the work done by certain other engines on this road.

The cylinder tractive effort at starting is 19,500 lb. and at 60 m.p.h. about 6,500 lb. As compared with certain saturated steam engines on this road, which are employed as a rule on lighter trains, the coal consumption is nearly 18 per cent lower, so that for equal loading the economy would be considerably more. The working temperature of the steam as delivered from the superheater is from 650 to 670 deg. F.

Of the total weight of 136,600 lb., 88,500 lb. is available for adhesion purposes. The tender is of the six-wheel type with capacity for 4,000 gallons of water and six (long) tons of coal. It is equipped with steam operated water pick-up apparatus. Its wheelbase is 13 ft.

The cylinders and valves are lubricated by means of a ten-feed Wakefield's lubricator and the boiler is fed by two 10 mm. injectors. The engine is fitted with automatic vacuum brake apparatus for the train, with hand or vacuum controlled steam brakes on the engine and tender, and with hand brakes on the tender.

On one occasion the locomotive illustrated hauled a train weighing 203 (long) tons from Leicester to London in 104 min. from start to stop, an average speed of about 60 m.p.h., which was for the most part exceeded to allow for the com-

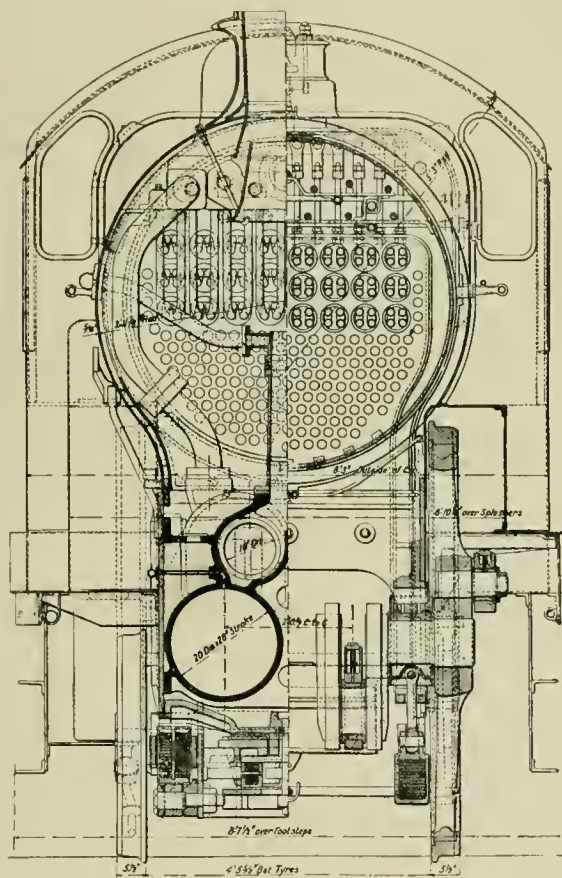

Cross Sections of the Great Central Locomotive

cylinders white metal gives trouble for the valve spindles, but not when they are below, because the steam is cooled in passing over the cylinder barrels on its way to the steam chest. The front ends of the valve spindles are carried by brackets cast on the front steam chest covers, a renewable cast-iron sleeve being fitted on the end of the spindle to take the wear. The back end of the spindle is supported by a special three-bearing bayonet joint which transfers the valve drive from the center line of the valve rod to that of the spindle. The engines are fitted with the Stephenson type of valve motion.

The engine truck has a cross travel of 6 1/2 in. which is controlled by a strong elliptic spring. It is otherwise of the ordinary construction with cross slides and the usual spring arrangement.

The boiler, which has a diameter at the front end of 5 ft. 0 1/2 in. outside and 5 ft. 3 in. diam. outside at the firebox end,

pulsory reductions of speed at the various slow down points. The following are the leading particulars:

Cylinders, diameter and stroke.....	20 in. by 26 in.
Driving wheels, diameter.....	6 ft. 9 in.
Truck wheels, diameter.....	3 ft. 6 in.
Wheelbase, driving.....	10 ft.
Wheelbase, engine and tender, total.....	48 ft. 8 1/2 in.
Heating surface—	
Tubes.....	1,502 sq. ft.
Firebox.....	157 sq. ft.
Total evaporating surface.....	1,659 sq. ft.
Superheater.....	210 sq. ft.
Grate area.....	26 sq. ft.
Working pressure, per sq. in.....	180 lb.
Weight on drivers.....	88,500 lb.
Weight of engine in working order.....	136,600 lb.
Weight of engine and tender in working order.....	244,700 lb.

## HEAT TREATMENT OF CARBON-STEEL LOCOMOTIVE AXLES: WATER VS. OIL QUENCHING\*

BY C. D. YOUNG  
Engineer of Tests, Pennsylvania Railroad, Altoona, Pa.

The investigation reported in this paper was made in order to show the difference between the physical properties of a large forging quenched in water and those of a similar forging quenched in oil.

The results obtained indicate that there is an advantage in the use of water as a quenching medium, as might be expected from its physical properties. Results obtained at a large heat-treating plant, which has turned out thousands of tons of quenched and tempered carbon steel, indicated that no disastrous effects on the forgings are to be anticipated from the use of water as a quenching medium, providing proper care is taken in the handling of the steel throughout the process.

The forgings used for this experiment consisted of two 10-in. locomotive driving axles having a center bore 2 in. in diameter extending the entire length. Both axles were from the same melt of steel, and preliminary chemical analysis indicated the same chemical composition. One axle was treated at the Juniata Shops of the Pennsylvania

*Oil Quenched.*—Similarly, the other axle was quenched in a heavy oil from the same temperature (1,550 deg. F.) and drawn in a furnace to 1,200 deg. F., the cooling being done in the air the same as for the water-quenched axle.

The object aimed at in the above treatment was to have the tension tests on both axles show an elongation in 2 in. of about 22 per cent.

After treatment, the axles were laid off for cutting up into tension test specimens as shown in the diagram. It will be noted in effect that out of each axle there were cut—axially and for the full length, 120 deg. apart—three

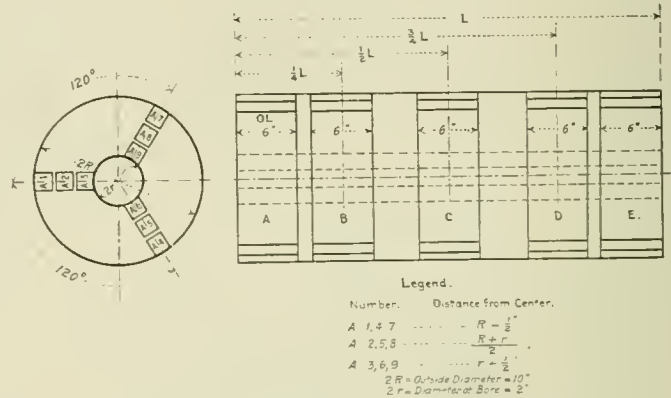

Location of Test Specimens Cut from Axles

radial and straight slabs of the overall-thickness of a test specimen, and out of each slab five 6-in. lengths, each identified as to its original location in the axle, whether cut from the end and from which end, or whether from the center, or from midway between center and end, and from which slab; and then each 6-in. length was cut lengthwise into three specimens and their locations further identified as to whether cut from the inner or outer circumference or from the middle of the wall. The identification marks for the five 6-in. lengths, in order from one end, are respectively A, B, C, D, and E. It is also shown that the specimens from

TABLE I—SUMMARY OF RESULTS OF TESTS

Location from		Specimen Marks		Elastic Limit. Lb. per sq. in.		Tensile Strength. Lb. per sq. in.		Elongation in 2 in. Per cent		Reduction of Area. Per cent	
End	Axis	Water Quenched	Oil Quenched	Water Quenched	Oil Quenched	Water Quenched	Oil Quenched	Water Quenched	Oil Quenched	Water Quenched	Oil Quenched
OL	.....	W A	O A	54,857	51,250	97,111	97,650	22.1	23.2	39.9	41.9
L/4	.....	W B	O B	52,634	52,160	96,637	97,304	22.8	25.2	40.3	45.7
L/2	.....	W C	O C	55,626	51,230	96,472	96,880	23.7	25.1	44.0	46.8
3L/4	.....	W D	O D	56,064	51,170	96,470	96,030	23.1	23.5	42.5	40.7
L	.....	W E	O E	53,376	49,780	95,720	94,210	23.6	24.0	44.3	41.7
Average.....				54,509	51,118	96,482	96,415	23.1	24.2	42.2	43.4
Location from Center											
.....	R - 1/2 in.	W 1, 4, 7	O 1, 4, 7	55,216	51,423	94,187	93,719	25.6	26.0	52.7	49.7
.....	R + r / 2	W 2, 5, 8	O 2, 5, 8	51,064	48,390	95,508	92,572	24.4	25.5	44.5	45.8
.....	r + 1/2 in.	W 3, 6, 9	O 3, 6, 9	57,255	53,543	99,751	102,962	19.2	21.2	29.7	34.5
.....	R + r / 2	Minimum permitted by A. S. T. M. specifications		50,000		86,000		20.0		40.0	

Railroad by water quenching, and the other axle by a steel company which makes a practice of oil quenching.

*Water Quenched.*—The axle was heated to 1,550 deg. F., and at that temperature quenched in water at about 60 deg. F. Then, in a furnace maintained at 1,175 deg. F., it was heated to that temperature and cooled therefrom in the air on a dry ground floor. That is, this axle, after being quenched from 1,550 deg. F. in water at about 60 deg. F., was "drawn" to a temperature of 1,175 deg. F.

length A, for example, are numbered radially from the outside of the axle toward the axis, the three specimens from the first slab being numbered, as described, 1, 2, 3 throughout; second slab 4, 5, 6; third slab 7, 8, 9, respectively. The specimens from lengths B, C, D and E also have the same numbering as those of length A. The letter W applies only to the water-quenched axle and O only to the oil quenched. Altogether there were 45 specimens per axle, 15 specimens from the three longitudinal planes through the axle, and 9 specimens from all three slabs from each of the five 6-in. lengths.

\*From a paper read at the convention of the American Society for Testing Materials, Atlantic City, N. J., June 27-30, 1916.



The test specimens were turned up to the standard 2-in. gage length, 1½ in. in diameter. The elastic limit was determined by means of a strain gage. All tests were conducted on the same 100,000 lb. tension testing machine using a machine speed of 1/8 in. per minute for both the elastic limit and the tensile strength.

The results are summarized in Table I, in which it is shown that the average results are more nearly uniform with respect to the length of the axle than with respect to distance from the axis. This is probably due to segregation, as it was found by chemical analysis that the carbon content was not uniform throughout the section. Segregation is perhaps to be expected in the ordinary output of commercial forgings, but not to the extent found here. (See Table II for chemical segregation.)

A comparison of the average physical properties of all test specimens from both axles shows that with an elongation 4.5 per cent less than that of the oil-quenched axle, resulting from the difference in treatment, the water-quenched axle gave an elastic limit 6.6 per cent greater, about the same tensile strength and nearly the same reduction of area.

Table I gives the average results from all test specimens located equidistant from the axis in each axle. The average results from the outer test specimens at the location R—1/2 in. show the water-quenched axle to have about the same elongation as the oil-quenched axle, 7 per cent greater elastic limit, 5 per cent greater tensile strength and 6 per cent greater reduction of area.

The test specimens from the middle of the wall show lower elastic limit and tensile strength than either the outer or inner test specimens, except that the strength of the water-quenched axle at the middle of the wall was found to be somewhat higher than in the outer specimens. It is evident that this mid-region of the section was less affected by the heat treatment. The water-quenched axle, however, shows higher elastic limit and tensile strength in this region than the oil-quenched axle, although, as already stated, the average strength of the entire section came out very closely the same for both.

The results obtained from test specimens from the inner surface of the wall are not so consistent; that is, they show a higher elastic limit and a lower tensile strength, elongation and reduction of area for the water-quenched axle.

All of the forgings tested meet the requirements of the specifications of the American Society for Testing Materials, except that the elastic limit found in the middle of the wall in the oil-quenched axle is somewhat low.

TABLE II—CHEMICAL COMPOSITION OF SPECIMENS

Specimen Marks		Carbon, Per cent	Man- ganese, Per cent	Phos- phorus, Per cent	Sulfur, Per cent	Silicon, Per cent
Water Quenched	Oil Quenched					
WA 4	.....	0.53	0.56	0.019	0.031	0.159
WA 5	.....	0.53	0.56	0.018	0.030	.....
WA 6	.....	0.61	0.58	0.019	0.039	0.158
WE 4	.....	0.53	0.56	0.019	0.030	0.162
WE 5	.....	0.53	0.56	0.019	0.032	.....
WE 6	.....	0.61	0.57	0.025	0.040	0.299
WD 3	.....	0.62	0.57	0.023	0.042	0.176
.....	OA 4	0.55	0.56	0.018	0.030	.....
.....	OA 5	0.55	0.57	0.018	0.033	0.190
.....	OA 6	0.63	0.59	0.019	0.041	0.195
.....	OE 4	0.52	0.55	0.021	0.036	0.167
.....	OE 5	0.54	0.56	0.019	0.031	0.182
.....	OE 6	0.60	0.59	0.019	0.038	.....
.....	OD 9	0.62	0.57	0.020	0.044	0.176

Table II gives the chemical analysis of representative test specimens taken from each axle. The water-quenched axle samples, taken from the A end, show that the outside and midway specimens W44 and W45 have the same carbon content, but when compared with analysis from specimen W46 of the inner wall there appears a segregation of 15 per cent. The same is true of the samples taken from the opposite end of this axle.

In the oil-quenched axle also, the same segregated condition is present, the outer and middle test specimens having about the same carbon content, while the specimens O46 and

OE6, taken close to the inner surface, show a segregation of 14.5 and 11 per cent, respectively, when compared with the corresponding samples taken from the middle of the wall.

The segregation found in both of these axles indicates a condition which increases the difficulty of securing a satisfactory treatment of the forgings, and points to the desirability of including in all specifications for forgings which are to be heat treated, a clause to govern the allowable amount of segregation; otherwise it may be expected that extreme segregation will be found, as in the forgings here discussed.

## THE USE OF PULVERIZED COAL AS A FUEL\*

BY JOSEPH HARRINGTON

Powdered coal has been under consideration as a fuel for over 20 years, and its apparent advantages have attracted the attention of engineers throughout this time. During the past five years the use of this grade of fuel has come into active practice. In order for it to produce satisfactory results it has been found necessary to limit the percentage of moisture in the coal to one per cent as a maximum, not only for the sake of combustion efficiency, but for the sake of more perfect pulverization. The standard of pulverization has been established as follows: 85 per cent of the fuel must pass through a 200-mesh screen and 95 per cent must pass through a 100-mesh screen. Broadly speaking, the greater the volatile combustible content in the coal the more rapidly will it ignite and burn, and the less dependent will be this process upon the size and proportions of the combustion chamber. As the volatile content decreases, however, more dependence must be placed upon the proportions and location of the surrounding brick work in order to maintain the temperature until ignition is complete. Anthracite coal has been burned in a pulverized form, but it must be very finely ground, and must be burned in a rather confined space so that the ignition may be prompt, and aid rendered by nearby brick work during the period of early combustion.

*Pulverizing Machinery.*—Several types of machinery which are commercially marketed will satisfactorily pulverize coal. They are divided broadly into air separation machines and screen machines. In the former class there is an upward current of air produced by a fan which has a carrying capacity sufficient to take with it the finest particles, but which will not lift the coarser ones. These fine particles are deposited in a receiving tank by a cyclone separator.

*The Burner.*—It is now generally conceded that the most efficient results in burning powdered fuel are obtained when the coal dust is carried into the furnace in a stream of air, the volume of which is just sufficient to supply the oxygen necessary for its complete combustion. This mixture of coal and air must be made in fairly close proximity to the furnace. The reasons therefor are that when this mixing is done there is produced an explosive compound, which it is not desired should be of any greater extent than necessary. The velocity of the entering jet must be greater than the rate of flame propagation to prevent burning back into the pipe. The other reason for making the explosive mixture close to the furnace is that there is a tendency for the coal to separate and lose its uniformity of mixture, under which condition it is obvious that part of the jet would be oversupplied with coal and the other part oversupplied with air.

*Objections and Difficulties.*—Where a blowpipe effect of the powdered fuel flame is obtained, the heat of a high-velocity jet will melt out the brick work upon which it is impinging. Difficulty is also experienced by minute particles of the liquid slag being carried on in suspension and deposited upon the tube sheet or water tubes of the boiler, closing up the flame space and putting the boiler out of

\*Abstract of a paper presented at the meeting of the Chicago Section of the American Society of Mechanical Engineers on May 15.

action. These defects are particularly noticeable with certain grades of coal.

*Advantages.*—From the viewpoint of the theorist, powdered coal is one of the most attractive propositions ever advanced for the promotion of combustion efficiency and commercial economy. There are in all transformations of energy unavoidable losses, and we are not possessed of apparatus which will gasify coal with 100 per cent efficiency. In the producer there is a string of losses which reduce the available heat in the gas to a considerable extent, and in the mechanical stoker there are unavoidable losses due to various forms of incomplete combustion. Only in the case of powdered coal is the actual solid fuel both gasified and completely consumed directly within the chamber desired to be heated. With perfect pulverization the entire mass is burned in suspension and in actual practice, but a small fraction of one per cent is actually lost in flue dust or slag pans. On account of the fuel being conveyed into the furnace by the very air which is afterwards to be used in its combustion, and on account of the diffusing of the coal throughout the air in a cloud-like formation, there is a possibility of a mixture which can be secured by no other means. Each particle of coal is surrounded by a particle of air, and on account of the extreme fineness of the particle practically complete oxidation occurs. The result is efficient combustion, and we have to deal only with the effects of the high temperature thereby obtained. It is now possible to control this temperature without sacrificing any material gain. Moreover, the definite control of the amount of air per unit of coal permits perfect variation in the results.

*Stationary Practice.*—Steam generation by the use of powdered coal as a fuel in stationary practice is still in the experimental stage, and herein, if anywhere, powdered coal will meet with severe competition. With the exception of the Missouri, Kansas & Texas installation at Parsons, Kan., which is now being put in by the Fuller Engineering Company, all of the steam-making installations are in the plants of manufacturers of powdered coal equipment, or in plants very directly connected therewith. That steam can be efficiently produced in this way is unquestioned, if the mere matter of combustion and evaporation is concerned. Whether it can be done more economically than is at the present time done by the best mechanical stokers will still remain to be commercially proved, and even with the powdered coal gas, analyses better than 16 per cent of  $\text{CO}_2$  are not developed. With the mechanical stoker the  $\text{CO}_2$  can be maintained around 14 per cent. With powdered coal the loss in the ash-pit and in the tubes does not exceed one per cent, and the best mechanical stokers will not exceed two per cent of the coal fired. A possible advantage in favor of powdered coal of two or three per cent in combustion efficiency is offset by the cost of fuel preparation. It is not reasonably to be anticipated that we can get better than 96 per cent efficiency, and this is a figure which can be obtained by the mechanical stoker.

*Ash Fusibility.*—A phase of the combustion problem is a study of the temperatures and conditions under which ash will melt. It has been found that coal ash will melt at temperatures between 2,200 and 2,700 deg. Furnace temperatures in commercial practice run between 1,800 and 2,800 deg., so that it is possible to secure coal, the ash from which will pass through the furnace without fusing. There is no hard and fast rule which can be stated for the selection of a coal. The temperature obtained in service, which is a function of the rate of combustion, the amount of excess air, and the proportions of the furnace chamber must be determined and an analysis of the fuel made to determine whether or not it will be suitable under the given conditions. In powdered coal work, with a more precise and scientific manner of the combustion process, the necessity for the proper knowledge of the fusing point of ash is greatly increased.

The Commercial Testing and Engineering Company has determined that washing a dirty coal made no difference in the fusing point of the ash, so that mere ash content is not the determining factor of the desirability when considering a coal for pulverization. The importance of this preliminary investigation can scarcely be overestimated.

*Conclusion.*—Powdered coal is radically different in its physical structure and method of handling from any other form of coal hitherto commercially used. Having marked characteristics it will fit into certain cases with extreme acceptability and will probably prove just as undesirable in certain other cases. Probably the most important difference is the burning of the actual solid fuel directly within the chamber and in direct physical contact with the objects to be heated. There is, of course, an appreciable amount of incandescent carbon in the furnace at all times, and this solid fuel is emitting radiant heat in close proximity to the furnace content. A large amount of the radiant energy is therefore directly utilized, which is not the case with the gasification of coal in a detached chamber. I cannot but conclude, therefore, that the success of powdered coal lies in its adaptability to the special furnaces of the metallurgical field, and in those cases similar to the locomotive where there are other and weighty considerations in addition to the actual relative increase in combustion efficiency.

### A VARIABLE EXHAUST NOZZLE

The British Board of Trade has been calling attention to the special need at the present time of economy in the use of fuel, and the possible savings by the use of variable exhaust nozzles has been more or less under discussion. A recent design of such a device is shown in the accompanying illustration. This exhaust nozzle is the invention of J. H. Jones, of Merthyr Tydfil, England, and it is claimed to materially reduce the deterioration of firebox sheets and tubes because of a more uniform draft on the fire. The engineman can

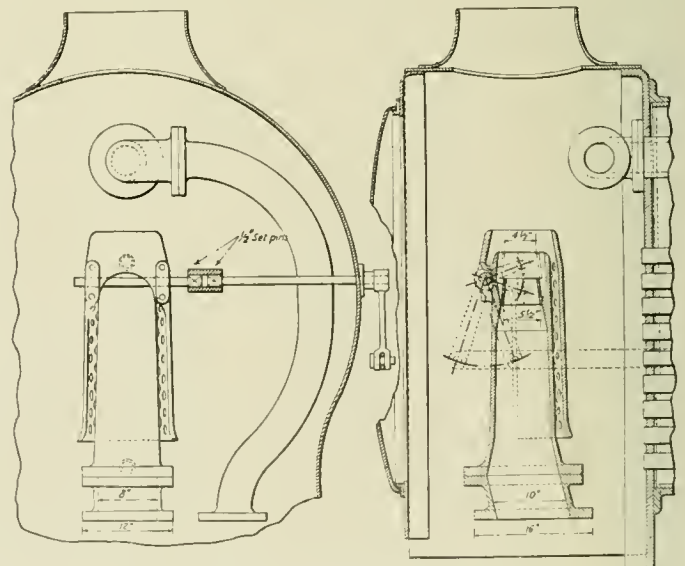

Jones Variable Exhaust Nozzle

regulate the draft from the cab by means of a rack having five or more notches so that the controlling lever can be fixed in any desired position. This results in obtaining what practically amounts to five nozzles of different sizes. No strong draft is necessary at any time and a considerable reduction in the amount of smoke given off results. The device also permits the use of a large size nozzle when starting, thus increasing the power of the engine when it is accelerating the train. A 25 per cent fuel economy is claimed as a result of the use of this type of nozzle.

# Car Department

## STEEL FRAME AUTOMOBILE CARS

The Wheeling & Lake Erie recently purchased from the Pressed Steel Car Company 200 automobile cars of the single sheathed type, with steel under and body framing. The underframe in itself is not intended to carry any load except in so far as it transfers the load distributed over the floor to the truss formed by the side framing of the car. The center sills are built to resist buffing only, consisting of 12-in. rolled channels weighing 35 lb. per foot, spaced 12 $\frac{7}{8}$  in. back to back with the flanges turned outwardly and extending from end sill to end sill. They are tied together and reinforced at the top with a  $\frac{1}{4}$ -in. cover plate running their

center and side sills. Each of these is reinforced at the top and bottom with 5-in. by  $\frac{3}{8}$ -in. plates. The body bolster is of the box type, made of  $\frac{1}{4}$ -in. pressed diaphragms, located between the center and side sills and having a steel casting between the center sills with 14-in. by  $\frac{1}{2}$ -in. top and 14-in. by  $\frac{7}{16}$ -in. bottom cover plates. The floor is of 1 $\frac{3}{4}$ -in. tongued and grooved yellow pine, resting on the side and center sills, and on two intermediate yellow pine stringers.

The side framing of these cars consists of an angle extending from end to end and forming the side plate, to which is riveted a 12-in. by  $\frac{1}{4}$ -in. plate extending from corner post to door post for use in attaching the side posts and braces, which are 3-in. 6.7-lb. rolled Z-bars. The door posts are



Wheeling & Lake Erie Steel Frame, Single Sheathed Automobile Car

whole length. The sills are located 2 ft. 4 $\frac{1}{2}$  in. from rail to bottom of flange, under which condition they meet the M. C. B. requirements of area and ratio of stress to strain. The end sill arrangement consists of a heavy steel casting around the coupler opening forming the striking plate, with 10-in. rolled channels weighing 15 lb. per foot, extending between the striking plate and the side sills. They are tied to the side sills, which are also 10-in. 15-lb. rolled channels, with malleable iron push pockets. There are seven floor beams consisting of flanged diaphragms made of  $\frac{1}{4}$ -in. pressed steel, located between the center sills and between the

4-in. by 3 $\frac{1}{2}$ -in. by 5/16-in. rolled angles. These members, together with the side sill channel, form the carrying truss of the car. The siding is 1 $\frac{1}{2}$ -in. tongued and grooved yellow pine, bolted to the inside of the side frame members with  $\frac{1}{2}$ -in. carriage bolts.

Each side of the car is provided with a 10-ft. door opening, equipped with double doors, so arranged that an opening of either 6 ft. or 10 ft. may be obtained. The center of the 10-ft. opening is 2 ft. 6 in. off the center of the car, the two centers are located diagonally opposite. The doors are made of yellow pine sheathing and framing 13/16 in. thick

and are equipped with Camel fixtures. It was believed that end doors were not necessary, the ends of the car are of solid steel construction of the Murphy type. These are riveted to rolled angle corner posts which are tied to the side sills with diagonal tie straps. Each end is provided with a flange at the top to form the end plate of the car and one at the bottom for riveting to the end sill. This bottom flange also supports the floor at the ends, making the car grain tight.

The roof is of the outside metal type, having rolled tee carlines. The inside measurements of the car are 8 ft. 6 in. by 9 ft. by 40 ft. 5 in., the height from rail to top of running board is 13 ft. 8 $\frac{7}{8}$  in., the width over all is 9 ft. 11 $\frac{1}{2}$  in., and the length over striking plates, 42 ft.  $\frac{1}{2}$  in. The cars are of 80,000-lb. capacity and weigh 42,600 lb.

The cars are equipped with the following specialties: Westinghouse air brakes, Sharon cast steel couplers, Carmer coupler release rigging, Imperial Appliance Company's coupler centering device and Miner friction draft gear with two-part cast steel yoke, having key attachment. The trucks are the Bettendorf type, having cast steel bolsters with Stucki side bearings, Barber lateral motion device, cast iron wheels, M. C. B. No. 2 brake beams and steel back brake shoes.

## THE PASSENGER CAR TERMINAL YARD\*

BY W. W. WARNER

Foreman Car Department, Erie Railroad, Cleveland, Ohio

The passenger car terminal repair yard answers about the same purpose for the car department as the roundhouse does for the locomotive department. It is a place where a very careful inspection is made of every visible part of the car, where all light repairs that can be completed in a few hours are made and supplies furnished for the next trip.

It is very important that the repair yard be located near the passenger station from which the trains depart; this saves excessive terminal expense. The layout should be such that the cars can be readily switched from either end. It frequently happens that at the last minute an additional car is ordered placed in the train, and this can be done in a short time if the yard is open at both ends. There should be plenty of track room and a liberal amount of space between tracks so that there will be no danger of personal injury to employees by cars moving on tracks adjacent to the one on which the employee is working. The location should also be such as will permit of a good drainage system. The yard should be planked or otherwise covered and kept clean.

The following facilities are quite necessary: A good water system, a good steam heat plant, a compressed air plant that will maintain a maximum pressure 24 hours a day, a drop pit for removing wheels and pedestals, a vacuum cleaning system for cleaning cushions, etc., and all the necessary tools and buildings, such as ice storage house, office, a storeroom for supplies, a small workshop for the carpenter and blacksmith work, and a room for the employees. These rooms should be equipped with individual lockers, a table for the use of the employees, and a place for them to wash up.

A good location and layout and the proper facilities mean much toward successful operation, but without a good live organization the desired results will not be obtained. First of all we must have a good live foreman who understands the operation from A to Z; a force of the very best car inspectors; the necessary number of good repair men; a good steam heat man; an air brake man who keeps up to date on the latest developments in passenger car brake equipment; an inside inspector who knows what is required and sees that it is done; a force of pipe fitters who can make all repairs to air, steam, signal, water and gas fixtures; an electrician, a carpenter (or more than one, if necessary), and a blacksmith and helper. The size of such an organization will depend,

of course, upon the number of cars handled. The force should be capable of increase or decrease on short notice.

The first move of importance after a train arrives in the repair yard is a careful inspection to see if any repairs are necessary that will require that a car be switched out. The inspectors in charge of the steam heat should see that the steam heat system on the cars is properly drained to avoid freezing in cold weather. The air brake men should also look over the brake equipment to see if there are any defects that require their attention. Much depends upon the proper maintenance of the air brake. A very careful inspection of the brake rigging, trucks and draft rigging is necessary. The absence of one cotter may mean a car failure or possibly a derailment. The couplers should be gauged for height, and also for wear of the knuckle and lock to avoid break-in-tows. The journal boxes should be examined each trip. All of the interior appliances should be examined to see that they are in proper working order; the more important of these are the lighting system, the water system, the drips from sinks, basins, etc. The seats should be examined to see that they are not defective and that there are no projecting screws or other objects that might cause passengers to tear their clothes. The toilets should be thoroughly scrubbed and disinfected, the floors scrubbed and the seats dusted, preferably with a vacuum cleaner, the interior of the car wiped and the windows cleaned inside and out. The train should be made up as early as possible so that the air, steam and signal system can be tested for leaks so that any defects that might develop while the cars are being switched can be taken care of before the train is due to depart. There should be a specified time for the road engine to couple on and a record kept of the time the engine is actually coupled to each train. This will prompt engineers to get engines on the train on time.

The foreman, yard master and station master should keep in close touch with each other to prevent delays.

## DEPRESSED AISLE STRIPS

The Union Pacific is using depressed aisle strips in the floors of coaches and chair cars. The strip is linoleum, 18 in. wide and set in flush with the top of the Flexolith flooring. It is continuous, extending the full length of the passenger compartment. The linoleum is applied to the flooring with a heavy coat of linseed oil or a suitable cement, and is then securely tacked to the wood stringers over the center sills with small galvanized barbed nails. The linoleum used is  $\frac{1}{8}$  in.

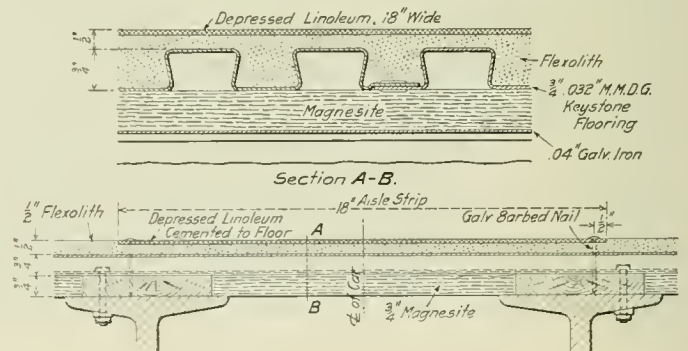

Depressed Aisle Strip for Coaches and Chair Cars

thick, composed of inlaid alternate red and green blocks, 1  $\frac{13}{32}$  in. square or 2 in. diagonal. The blocks are laid diagonally and the strips are cut along the diagonal center line of the red blocks to form the edges for the sides to match the color of the Flexolith flooring. The use of the strips in this way is sanitary and also tends toward safety, as it prevents passengers from tripping over the edges of the strips.

A maroon coloring matter is mixed with the Flexolith flooring compound, which eliminates the frequent necessity of repainting floors.

\*Entered in the Car Terminal Competition.

# FREIGHT CAR CARPENTER APPRENTICES

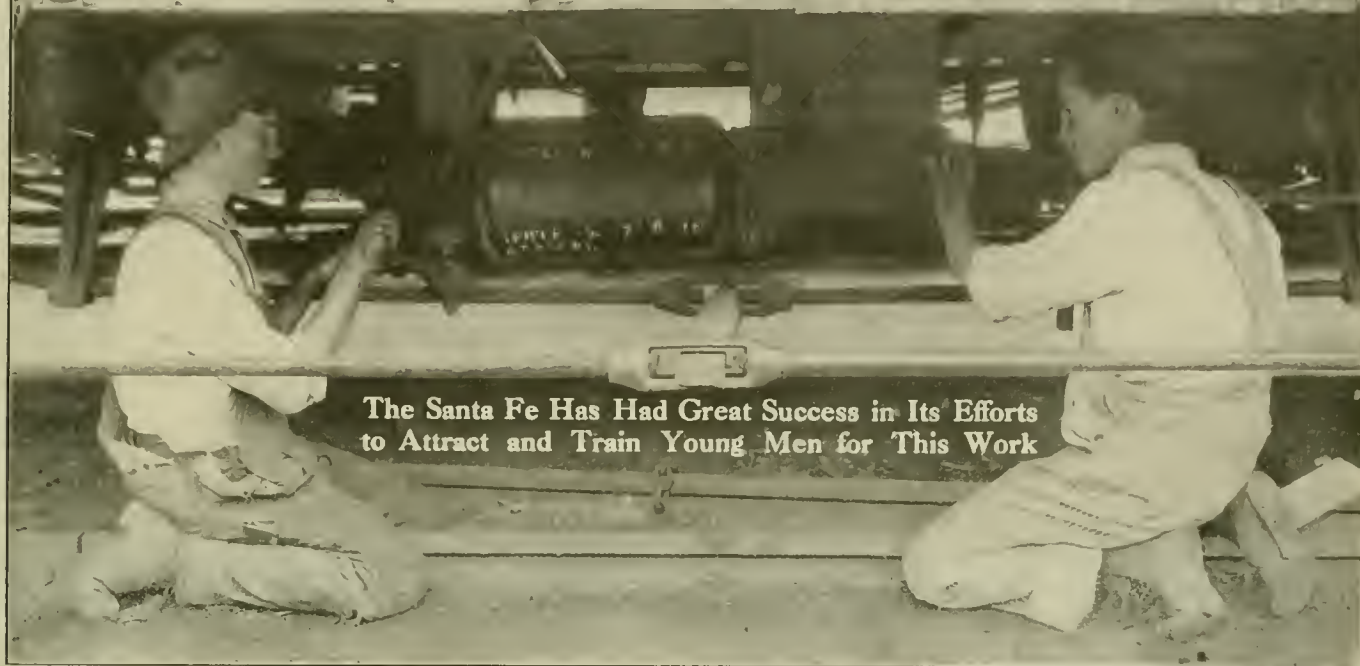

The Santa Fe Has Had Great Success in Its Efforts to Attract and Train Young Men for This Work

Freight Car Apprentices on Air Brake Work

CAR department officers have found great difficulty in holding apprentices and in developing thorough courses of instruction for them. The Santa Fe started to provide adequate training for freight car carpenter apprentices about two years ago and, because of the results, has been encouraged to broaden the course very considerably. So important is this work regarded that a considerable part of the time of the annual conference of apprentice instructors\*, which was held at Topeka in May, was given over to a discussion of its problems.

ADDRESS BY MR. SWANSON

C. N. Swanson, superintendent of the car shops at Topeka, spoke to the apprentice instructors concerning freight car carpenter apprentices. Among other things he said: There is one word that is uppermost in the minds of the American people today, and that is "preparedness." The government is just awakening to the fact that it must prepare. The Santa Fe woke up several years ago and started the apprentice system to prepare the men who are to run it in the future. This organization is like one big cog wheel, each one of us being a cog in the wheel. The man who works on draw-bars of the cars is as necessary a part of this organization as any of the higher officers. The part the freight car carpenter plays is to prepare a vehicle to haul the one thing a railroad has to sell—transportation. There are many who do not thoroughly appreciate the importance of freight cars, but when it is considered that thousands and thousands of dollars are spent for loss and damage due to defective equipment, the importance of the car repair man becomes apparent. A small defect, such as leaky construction, often means considerable money spent in claims, all of which means that a job worth doing is worth doing right. Don't turn these cars off the repair track, expecting the next division point to take them and repair some part that you left undone.

\*An account of the general problems which were discussed at this conference will be found in the *Railway Mechanical Engineer* of July, page 363.

It is necessary for the apprentice instructors to use discretion in placing the boys in the different gangs. It is good practice to bunch the more advanced boys together, rather than to have one of the gang hold them back in their work, which is at best discouraging. Those boys who started their apprentice course some time ago have been placed in gangs on what is called the heavy side, rebuilding cars from the ground up, and the men in the gangs are very much pleased with the work they do. Care must be taken in selecting the boys when they apply for an apprenticeship. It is highly desirable to have as large a waiting list of prospective apprentices as possible in order to keep the apprentice ranks full at all times.

Following Mr. Swanson, David Hurley, general foreman of the freight car shops at Topeka, gave a brief talk, testifying to the good work being done by his freight car apprentices, particularly those who had been in service a year or more. He said that the present method was far superior to the former method of recruiting and training freight car carpenters by the student system.

## CAR INSPECTION

H. L. Shipman, general equipment inspector of the Santa Fe, gave a talk on Overhead and Terminal Inspection, at the Thursday afternoon session. He called attention to the important defects met with in car inspection, speaking particularly on the necessity of proper inspection of car roofs and doors and draft rigging. He showed samples of defective car brasses which caused hot journals. In some of the journal boxes having the six or four-pocket type wedges, the ribs on the wedge will cut into the box, so that in time the wedge will bear solid on the box and have no opportunity for rocking when a suddenly applied pressure, such as caused by the butting of two cars together, is applied to the brass by the journal. This very often results in a broken lining in the brass which will in time work down the side of the brass, giving an uneven bearing and causing the journal to run hot. Brasses defective in this way can be located only

by feeling the brass to determine whether or not the lining is working out.

#### APPLICANTS FOR FREIGHT CAR APPRENTICESHIP

J. A. Daughtie, apprentice instructor in the freight car shop at Cleburne, Tex., presided over the discussion of this subject. It was unanimously agreed that each applicant should be examined both by the school instructor and the shop instructor. It was believed that any young man who was old enough to be an apprentice, who had not learned to add, subtract, multiply and divide, and handle simple fractions, was lacking in either mentality or ambition, and in either case would be unlikely to make good as an apprentice.

At some shops good results had been obtained by choosing boys already employed in the shop, some of these coming from labor gangs. Most of the instructors, however, reported that they had not obtained very good results from young men selected from the labor gang. In general no difficulty had been found in obtaining a sufficient number of good applicants. The instructor, by letting the other boys and men in the shop know that there was an opening for an apprentice in this trade, usually received a number of applications from which he could select the most promising

would be willing to go to other shops where they may receive employment at once.

#### SCHEDULE FOR FREIGHT CAR APPRENTICES

W. H. Heins, apprentice instructor at the freight car shop, Albuquerque, N. Mex., presided. The work of training men for the car department was started about two years ago, and as the course is 2½ years, none of the apprentices have been graduated. Each apprentice is assigned to various classes of work as follows:

Truck work .....	2 months
Wheel shop, inspection of wheel and axle defects....	1 month
Draft rigging couplers, etc.....	1 month
Body, framing and light repairs.....	6 months
Steel work .....	3 months
Planing mill, laying out work.....	1 month
Car roofs, doors and interior work.....	2 months
Heavy repairs .....	9 months
Air work in air room.....	1 month
Air work, repairs to cars on repair track.....	2 months
Car inspecting .....	2 months

Total ..... 30 months or 2½ yrs.

It is not intended that this schedule be followed to the letter at all points as local conditions may necessitate certain changes, but it should be used as a guide and adhered to as closely as possible. The value of each class of work men-



Freight Car Apprentices Fitting Up an End Sill

young man. It was agreed by all that the best way to secure good applicants was to see that the apprentices already employed were given every possible opportunity to learn the work; and that these boys who were well satisfied with the work would be the best advertisements the company could have in attracting other suitable material. A boy from a nearby small town usually brought a number of other applications from the same place; these are usually found to be good material.

Owing to the higher rate paid and the older age at which applicants are employed in this trade it is to be expected that a larger percentage will drop out in the early months of their apprenticeship, as some of them come wishing a job rather than a trade and leave when something more remunerative shows up. The instructors, however, by exercising care in the selection can reduce such cases to a minimum. It has been found that most of the men who drop out do so during the probationary period. Each shop should keep a waiting list of applicants for this trade the same as for other trades and those shops having a surplus of applicants should find out if the young men making application

tioned was pointed out and all instructors were urged to leave nothing undone toward preparing the freight car apprentices so that they may be fitted to do any class of work which arises in the freight car shop.

During the discussion particular stress was laid upon the necessity of giving the apprentices ample instruction in car inspection.

#### SHOULD FREIGHT CAR APPRENTICES WORK WITH JOURNEYMEN?

Peter Dahlstrom, apprentice instructor in the freight car shop at Topeka, acted as chairman. It seemed to be the general opinion that better results will be secured if the apprentices work in apprentice gangs rather than with journeymen, especially during the first year or year and a half of their apprenticeship. Apprentices should be grouped according to their ability and progress, care being taken not to hold back any of the older and more experienced boys because of the slowness or lack of experience of some younger or inferior boy. As the apprentices became more experienced and skilled they may be worked to good advantage

with journeymen, especially during the last year of their apprenticeship. This has been tried out with a number of the older boys at Topeka and their work has been so satisfactory that the journeymen were glad to have them with them. But in the earlier stages of the apprenticeship all agreed that the best results could be obtained from working the apprentices in apprentice gangs under the supervision of the apprentice instructor.

INSTRUCTIONS IN THE M. C. B. RULES

J. E. Saunders, apprentice instructor at Shopton, Iowa, acted as chairman. It was pointed out that the best way the apprentices can learn the M. C. B. rules is to have the instruction take place while they are doing the repair work. There is a possibility of correlating the work with the school instruction to good advantage. Mr. Swanson believed that it would be far better to take the boys to the repair tracks, explain the work being done and show them the rules governing these repairs. Particular stress should be laid on the important rules, which should be given out for study; the boys should be examined on them at the next school meeting. It is highly desirable to have the shop instructors attend the

to the boys, and that six months would be sufficient to give them a proper idea as to how the work should be handled.

SCHOOL ROOM INSTRUCTION FOR FREIGHT CAR APPRENTICES

C. B. Falkenstein, apprentice instructor at San Bernardino, Cal., acted as chairman. As the schedule for freight car apprentices now stands one hour a week is allowed for school room instruction. It was believed that more time should be given the boys in the school room, and that in addition to the M. C. B. rules they should be instructed in free hand sketching, a sufficient amount of arithmetic to properly compute dimensions and fill out car bills, some mechanical drawing and reading of blue prints, together with information concerning the relative cost of the material they have to handle. It would be possible also to advance the new apprentices in learning the fundamentals of car construction.

QUESTIONS FOR FREIGHT CAR APPRENTICES

H. E. Ralston, apprentice instructor in the freight car shop at San Bernardino, Cal., presided. In connection with this subject Mr. Thomas distributed a new list of questions for freight car carpenter apprentices, on which they should be examined before they are graduated from the course. There were 202 questions in all, a few of which are given below as an indication of what is expected of a graduate freight car carpenter apprentice.

- 30. What are the M. C. B. rules regarding the mating of wheels on axles?
- 31. What is the minimum thickness of a flange on wheels of a 60,000 lb. capacity car? Of a 100,000 lb. capacity car?
- 32. What is the cause of slid flat wheels?
- 33. What is the cause of cracked plates?
- 34. What are the indications of a loose wheel?
- 35. How should a pair of wheels be gaged?
- 36. Why may mounted wheels be full gage at one point and shy at another?
- 37. What are the more common wheel defects?
- 38. If a car wheel has vertical flange, is it safe to leave it under the car?
- 39. How are car wheels applied to axles?
- 40. What size should shelled out spots be on a wheel before the wheel should be condemned?

These questions are used for instruction and not as a means of "throwing" an apprentice.

THE NEED OF UNIFORM EQUIPMENT ON FREIGHT CARS\*

BY H. W. BAYLISS

While this subject is a general one, it is also one that merits deep thought. Knowing the trouble and delay occasioned because of the use of such a great variety of attachments on freight cars, I feel that there should be something said, as a forerunner for something being done to create more uniformity. Uniformity should be encouraged, from an economical standpoint alone. A few years ago the Master Car Builders' Association appointed a coupler committee to experiment and work out a standard coupler which would be interchangeable, irrespective of the manufacturer. There is a good deal of unwarranted expense entailed by the different railroads in the adoption of the many types of couplers and parts, and also operating attachments.

We should not leave the subject of a standard coupler without calling attention to the varied designs of coupler rear attachments we have in use. We have the twin spring rigging, the tandem spring attachment and numerous types of friction gear. While it may not be possible to bring about a uniformity of parts with respect to the rear attachments, it would seem that there is need for some standardization of them to avoid the necessity of carrying a large stock of this material and also to facilitate repairs.

Concerning the operating devices, of which there are many

\*From a paper read at the June meeting of the Niagara Frontier Car Men's Association, Buffalo, N. Y.



Freight Car Apprentice Repairing a Car Roof

school classes with the boys in order that the practical problems may be discussed and the instructors may be sure that they are thoroughly understood.

FREIGHT CAR WORK FOR COACH CARPENTER APPRENTICES

Frank Meyers, apprentice instructor in the freight car shop at Topeka, acted as chairman. The question at issue was whether or not the passenger car apprentices who are required to serve four years should be required to spend some time on freight car work. This has been tried in some cases, but it was found that as a rule the boys object to being required to do freight car work, feeling satisfied to restrict their field of endeavor to passenger cars. However, it was pointed out that if competent car foremen are to be made of these boys some experience in the freight car work is necessary, as this is the largest field in the car department and cannot be overlooked. The experience obtained by the boys, also, will permit of shifting them from passenger to freight work, in case of sudden demand for skilled work on freight cars. With the experience from working on the passenger cars it was believed that the freight work would come easily

of various designs, we have a great need for uniformity of equipment, as the multiplicity of designs makes it almost impossible to keep a stock on hand to meet all contingencies.

In the case of trucks, there are quite a number of different kinds and when we call to mind that this is a part of the equipment that means much for the safe movement of a car, I believe that we should put forth our best efforts to bring about a standard type or design.

The all-important matter of United States Safety Appliances calls for more uniformity of practice, not so much in the manner of application as in the design of the parts. Some roads elaborate more on these parts than others, in that the ladder treads are all manufactured with a foot guard and they are also of heavier iron. I notice also that there is quite a variety of sill steps and it is my belief that whatever is best should be adopted and thus create more uniformity of practice.

While I have referred to certain parts or attachments in setting forth my views, there are other attachments that come within this scope.

### SEVENTY-TON GONDOLA CARS

The Pennsylvania Railroad recently received from the Pressed Steel Car Company 2,000 gondola cars of 140,000 lb. capacity and weighing 49,500 lb. These have, in addition to the high carrying capacity mentioned, a great inside length and a short distance from rail to top of floor. Provision is made for the usual 10 per cent overload, and the de-

The inside length is 46 ft. 2½ in. The sides are equipped with collapsible stake pockets. These are out of the way when not in use and are, therefore, less liable to be damaged by the lading.

Pressed steel is largely used throughout. Some structural shapes are incorporated where they can be used to advantage, but such items as center sills, bolster diaphragms, floor beams, end sills, end braces, side stakes, hopper sheets, drop doors, etc., are made of shapes pressed out of steel plates. The plates forming the floor, side and end sheets, doors, hopper sheets and most of the floor beams are made of ¼ in. material. The center sills are 24 in. deep, made from a 7/16-in. plate, flanged top and bottom, and extending from end sill to end sill and are reinforced at the top with a ¾-in. plate and at the bottom with a 4-in. by ¾-in. angle. The body bolster is made of 5/16-in. plate reinforced at the top and bottom with ½-in. plates. The member forming the bottom chord of the side girder is made of a 4-in. by 4-in. by 5/8-in. angle, and the side is stiffened and held in place with 12 stakes made from 5/16-in. plates. The length of the car from center to center of couplers is 50 ft., and the over-all width is 10 ft.

The trucks have cast steel side frames which are tied together with pressed steel spring plank channels made of 9/16-in. material. Rolled steel wheels, open hearth steel axles and pressed steel journal boxes are used, the journals being 6 in. by 11 in. The bolsters are pressed steel and the brake beams are M. C. B. No. 2.

A freight car of the flat bottom gondola type, having a

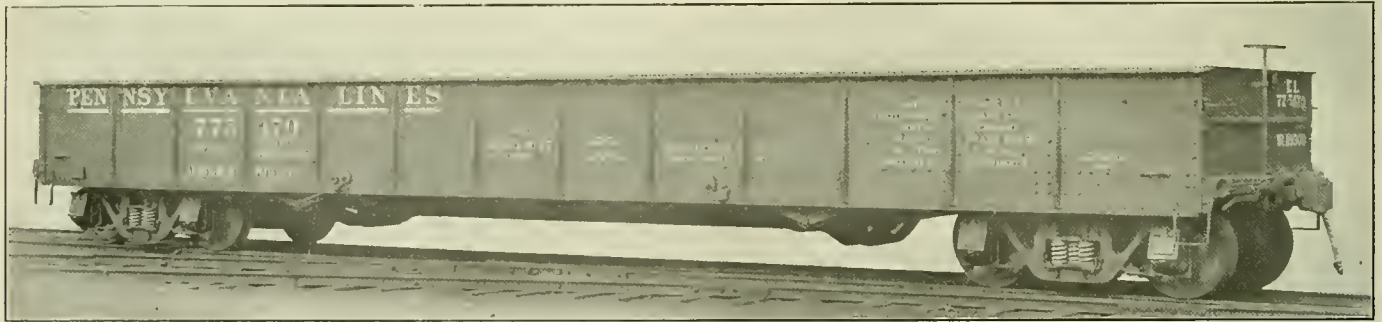

Seventy-Ton Gondola for the Pennsylvania Lines

sign is such that heavy concentrated loads can be taken care of. There are two heavy crossbearers in the underframe, designed to make the side girders and center sills work together. The height of the sides is only 3 ft., and the top of the sides is reinforced with special heavy bulb angles, 5 in. by 4½ in. by 1½ in. by 7/16 in. Four small hoppers are provided in

wood floor, but otherwise entirely of steel, has its advantages, inasmuch as the sides may be used as girders for carrying the load along with the center sills, which does away with the necessity of deep fishbelly side sills. In other words, the sides serve a two-fold purpose which is not possible with the low side composite car in which the sides are made of heavy

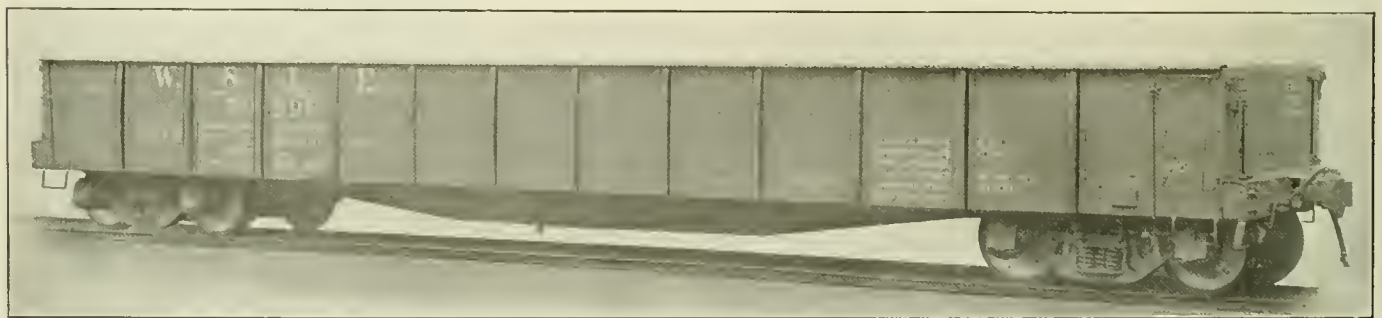

Seventy-Ton Gondola for the Wheeling & Lake Erie

the floor, each equipped with 2 doors. The doors are operated in multiples of four, with either the Lind or Simonton door operating device. The distance from rail to top of floor is only 3 ft. 4¾ in., which keeps down the height from the rail to the center of gravity of the loaded car. Excessive height may easily be the cause of derailment.

planks and which condition requires deep side sills or much heavier and deeper center sills with cantilever floor beams. The use of a wood floor in a car of this type retains the advantages of ability to secure and brace the lading. Where steel sheets are used for the sides a further advantage over the cars having wood side planks is obtained in an increase in



cubic capacity on account of being able to make the car from 6 in. to 7 in. wider inside and still maintain the same overall width. The floor of a low side car of this type, intended for heavy and concentrated loads, must necessarily be ample in thickness and well supported.

The Pressed Steel Car Company recently completed an order of such cars for the Wheeling & Lake Erie. The cars are of 140,000-lb. capacity and designed to carry a concentrated load of 100,000 lb. at the center. The clear length inside is 45 ft. 6 in. and the width inside of side sheets is 9 ft. 6 in. The height from floor to top of sides is 3 ft. The floor is of yellow pine 2 7/8 in. thick and rests directly on the center sill cover plate, an angle riveted to the sides and intermediate yellow pine stringers 4 in. by 4 in. in cross section. The

The center sills of these cars are of the fishbelly type, 30 in. deep at the center and 12 in. deep at the bolster and end, and are continuous without splices from end sill to end sill. Each sill consists of a 3/8-in. web plate, reinforced at the top with a 3 1/2-in. by 3 1/2-in. by 3/8-in. angle on the outside and at the bottom with two 4-in. by 3 1/2-in. by 7/16-in. angles. The two sills are tied together at the top with a 25-in. by 1/4-in. cover plate extending from end sill cover plate to end sill cover plate. This center sill cover plate is made extra wide to extend several inches beyond the center sill top angles, in order to provide space for securing the floor without the necessity of passing the floor bolts through the center sill top angle. The girder formed by the sides is 4 ft. 3 1/8 in. deep and is reinforced at the top with a 4-in. by 3 1/2-in. by

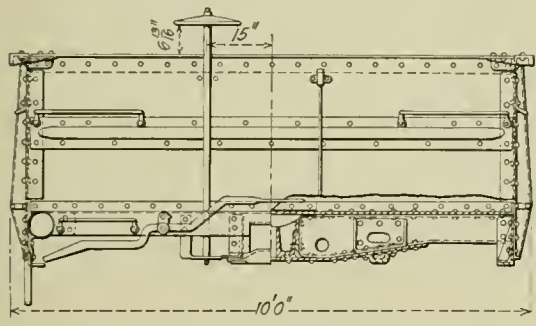

Section A-B.

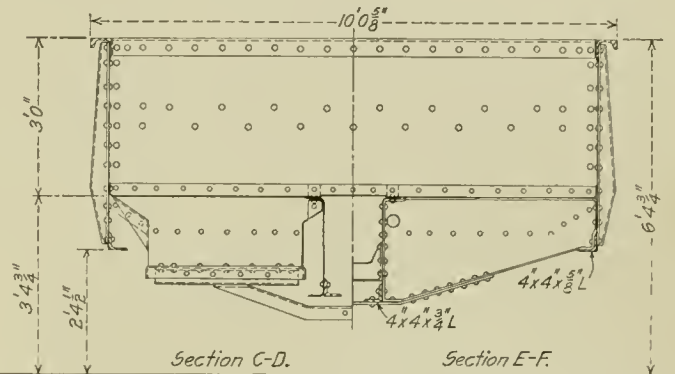

Section C-D.

Section E-F.

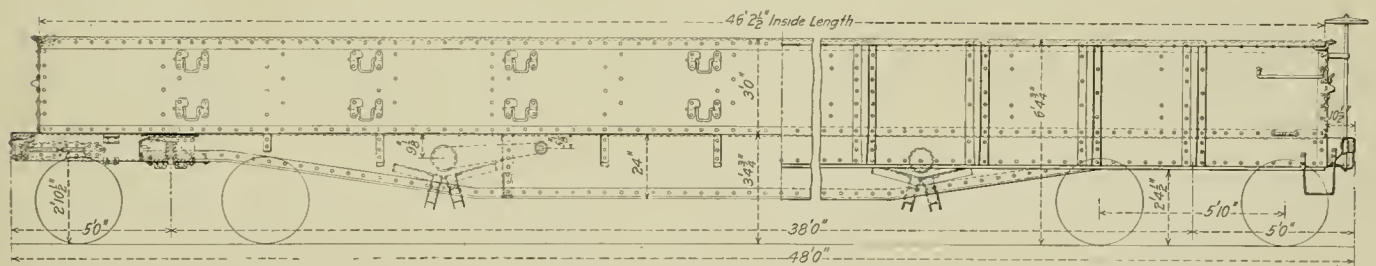
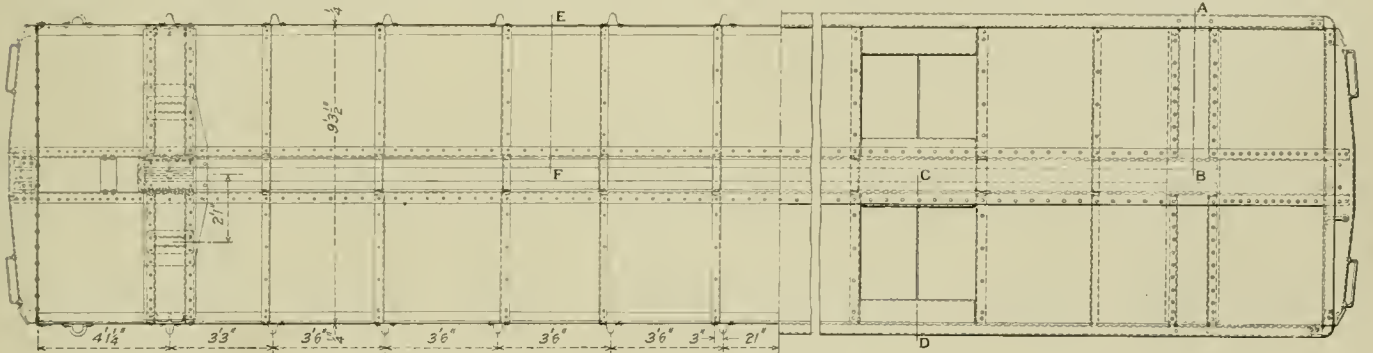

General Arrangement of the Pennsylvania Gondola

height from the rail to the top of the floor is 3 ft. 7 3/8 in. Each end of the car is provided with a special design of steel drop end gate which may be lowered to the floor of the car when hauling long material requiring twin loading. This end gate is made of 1/4-in. steel, stiffened transversely with three braces. The braces at the top and bottom are integral with the plate, it being bent in and around on itself, the flange riveted to the face, thus forming a hollow beam about 3 in. deep for the whole length of the gate. The other brace is a separate pressed steel piece and is riveted to the face of the sheet at the center. The ends of the gate are further stiffened by a vertical pressed brace riveted to each end. All the braces are on the inside, so that the end presents a flat surface on the outside. The inside of the car is equipped with 32 collapsible stake pockets.

1 1/2-in. by 1/2-in. bulb angle and at the bottom with a 4-in. by 3 1/2-in. by 1/2-in. plain angle. Each side is secured against bulging and stiffened with 12 pressed steel stakes made from 5/16-in. plate, each of which is located in line with either diaphragms, crossbearers or the body bolster. There are 4 crossbearers to effectively connect the side girders and center sills and to insure the proper distribution of stresses for all manner of loading. Besides these crossbearers there are 6 floor beams on each side of the car. The crossbearer diaphragms are made of 5/16-in. steel, the floor beams of 1/4-in. steel and the bolster diaphragms of 3/8-in. steel. These members are pressed from a plate to provide continuous flanges all around. The bolster top and bottom plates are 14 in. by 5/8 in. The end sill consists of a 12-in. rolled channel and is reinforced at the top with a 19-in. by

$\frac{1}{4}$ -in. plate and a 5-in. by  $3\frac{1}{2}$ -in. by  $\frac{7}{16}$ -in. angle, extending from side to side, the latter forming a bottom stop for the drop end gate.

The Wheeling & Lake Erie cars are equipped with Miner friction draft gear, Sharon couplers, Imperial Appliance Company's coupler centering device, Stucki side bearings, Westinghouse air brakes and Blackall drop handle brake ratchet. The trucks are of the cast steel Bettendorf type with cast steel bolsters, steel wheels and M. C. B. brake beams. The length of the car over striking plates is 48 ft. and the weight is 49,000 lb.

## PRESERVING THE LIFE OF STEEL CARS

BY H. M. CLARENCE

A very large share of the corrosion and decay of the steel car surface comes, in the main, from a lack of that protection which good paint and varnish affords. One need not be an expert in the technical features of painting or of chemistry to prove this. The layman may easily note that plain surfaces which are subject to the same service conditions as any other part of the car are almost without exception in a better condition than certain other parts which are less easily kept under an adequate coating of paint and varnish. It has been noted that the deck or clerestory of the car, the window sills and the parts immediately about the window sash, in and around which the moisture enters and lies, are prone, under the same measure of protection given the plain surface, to "fissure" and throw off the finish as the layers of rust and corrosion develop. This condition supplies the proof that the right sort of painting and varnishing is the protection which the steel surface must have in order to have a reasonable length of life and a good appearance.

Granting that the car as it comes from the builder has an ample and effective covering of paint and varnish, what is the treatment which it should receive, consistent with its value? We have been told in conventions and elsewhere, that the varnish should under reasonable treatment last for eight, nine, ten and even twelve months, and under the best care, some time longer than this. It is sound car economy, however, to apply varnish often enough to avoid straining the varnish, which is done when the shopping is postponed until the varnish is worn thin and thereby becomes less capable of withstanding the wear of service. The steel car has been long enough in use to show that a procrastinating policy in respect to the renewal of the paint and varnish is poor economy. If railway managements could arrange, without seriously interfering with traffic, to shop the steel passenger car twice a year for such paint and varnish renewals as the master car painter finds it necessary to make, the difficulties of premature corrosion, it is fair to believe, would be in large part satisfactorily settled. The surfaces most freely attacked by moisture and affected by corrosion could then be taken care of, both by the removal of the rust already present and the covering of the parts thus affected with paint as nearly rust-proof as can be obtained. All such surfaces require at these shoppings not one coat only, regardless of condition, but as many more, all carefully applied, as the condition of the old paint and the metal need to protect them beneath the finish. Varnish color or enamel should top off the primary coats and round out a finish capable of holding against all kinds of service. Over all will then be needed a covering of varnish. It is a matter of some speculation as to just how many coats of varnish will best answer the requirements. Probably the great majority of railroads employ two coats of finishing varnish for all passenger equipment cars, but the three coats usually given private cars, dining cars and other equipment of this order, bear out the assumption that three coats of varnish applied at each shopping will give a proportionately longer service, and during that service give

a much better appearance to the car, with its resultant advertising possibilities. A well-finished car is a continuous advertisement. Good facilities for comfort inside of the car have a value which all recognize, but the outside tells the story of the prosperity of its owners and the refinements which they are pleased to extend to the traveling public. The way that travelers dash for the best looking car in the train shows the advertising advantages of good outside finish.

The exposed underside of the floor is a part of the steel car which needs treatment at each shopping. This is a part of the passenger car which it is natural to pass without much attention. The inference sometimes is that the grease and foreign accumulations massed upon this space are in themselves an adequate protection, but investigation of such surfaces following any considerable period of service, unless they have been regularly and carefully painted, will disclose a corrosive condition requiring little short of heroic treatment to correct. The writer has examined corrugated steel express car floors which show patches of surface literally eaten through. If given thorough attention at the regular shopping of the car such destructive conditions could hardly be expected. All these parts of the car should have the grease and dirt removed, and as much of the rust and decay started loose and brushed away as is possible under the circumstances. Then with plenty of good paint worked into every crevice of the floor you will have a very essential part of the car properly taken care of. Eternal vigilance is indeed the price which paint shop protection of the steel car exacts. Without it, corrosion and premature decay are rampant. Thorough painting of all parts, with plenty of varnish where needed, is essential to maximum life and beauty.

## SHRINKAGE OF BOX CAR SHEATHING

Several roads which are extensive users of single-sheathed outside steel frame box cars have had difficulty due to the shrinkage of the sheathing after it is placed on the cars and the cars are in service. This was due to insufficient drying of the lumber before application. The slotted holes generally used to take care of adjustments for overcoming the effects of such shrinkage provide only  $\frac{5}{8}$ -in. or  $\frac{3}{4}$ -in. which it will be seen is entirely inadequate when we consider that in one order of automobile cars there was a shrinkage in a height of 10 ft. of from  $5\frac{1}{2}$  in. to  $7\frac{1}{2}$  in. These cars were built without specification being made as to the dryness of the lumber and in the next order of cars special care was taken to provide well dried lumber. Samples measuring approximately  $1\frac{1}{2}$  in. by 5 in. by 12 in. were placed for a period of 96 consecutive hours in a hot cupboard, the temperature being maintained at from 160 deg. F. to 180 deg. F. Any of the tested pieces which showed a reduction in weight of more than six per cent were considered improperly dried. It was found, however, that the long period of drying was inconvenient and very short samples of the same lumber were tested in various ways to determine on the shortest practicable time of drying. As a result of these tests the specifications for dryness required all samples to be taken from the middle portion of the stick. These samples are from  $\frac{1}{4}$  in. to 5-16 in. long and are dried for two hours in a hot cupboard at the temperature previously used. A shrinkage of more than 1-16 in. in a width of  $3\frac{3}{4}$  in. is taken as indication that the lumber is improperly dried. In view of the trouble that has been experienced by some roads this means of obtaining properly dried lumber for horizontally sheathed box cars should prove of value to any road considering the construction of this type of car. The cars as built under the first method referred to have proved entirely satisfactory and while no cars have as yet been built to the second specification, officers of the railway which has developed this method feel entirely confident that it will give as good results as the previous specification.

# BUFFING STRESSES IN BOX CARS

A Stress Analysis Which Includes the Horizontal Effect of Inertia Upon Body Frame Members

BY ROBERT N. MILLER

## I.

THE conditions which necessitate heavy and frequent repairs to freight cars are the use of defective material in construction and excessive stresses in the frame members and joints. The latter condition may be due either to faulty design or to rough and unfair usage. The proper limiting of the stresses in frame members is thus of vital importance to the life of the equipment and since unfair usage exists, the designer must provide for it.

From observations as to the nature of repairs made in repair yards as well as from dynamometer records obtained in road and yard service it has been noted that quite common switching practice involves the making of couplings at speeds of from five to ten miles per hour and that these speeds are checked in about six inches of total car movement either through draft gear resistance, impact or both. On this basis the following method of stress analysis employing both analytical and graphic methods has been developed and applied to box car design.

Every moving body by virtue of its velocity, may be considered a storehouse of kinetic energy and it is when this energy must be rapidly dissipated that the intensity of the retarding force is realized. Owing to the characteristics of

$$\text{then } f = \frac{(V_1^2 - V_2^2)}{2S} \times \left( \frac{5,280}{60 \times 60} \right)^2 = \frac{(V_1^2 - V_2^2)}{S} \times 1.075$$

$$\text{and } P_1 = \frac{Wf}{g} = \frac{1.075}{32.2} \times W \times \frac{(V_1^2 - V_2^2)}{S}$$

$$\text{or } P_1 = 0.0337 W \times \frac{(V_1^2 - V_2^2)}{S} \dots \dots \dots (1)$$

The maximum retarding force,  $P_{\max} = 2 P_1$

$$P_{\max} = 0.0674 W \times \frac{(V_1^2 - V_2^2)}{S} \dots \dots \dots (2)$$

Assuming an initial velocity of 10 miles per hour, and that the car is brought to rest in a distance of 6 in.,  $V_1=10$ ,  $V_2=0$  and  $S=0.5$ . Substituting these values in formulas (1) and (2):

$$P_1 = 0.0337 \frac{W \times (10)^2}{0.5} = 6.74 W \dots \dots \dots (3)$$

$$P_{\max} = 2 P_1 = 13.48 W \dots \dots \dots (4)$$

The numerical factor which multiplied by the weight of the moving body gives the maximum retarding force may be represented by  $K$  and formula (2) then becomes:

$$P_{\max} = K W \dots \dots \dots (5)$$

At the moment of impact the moving car can be considered

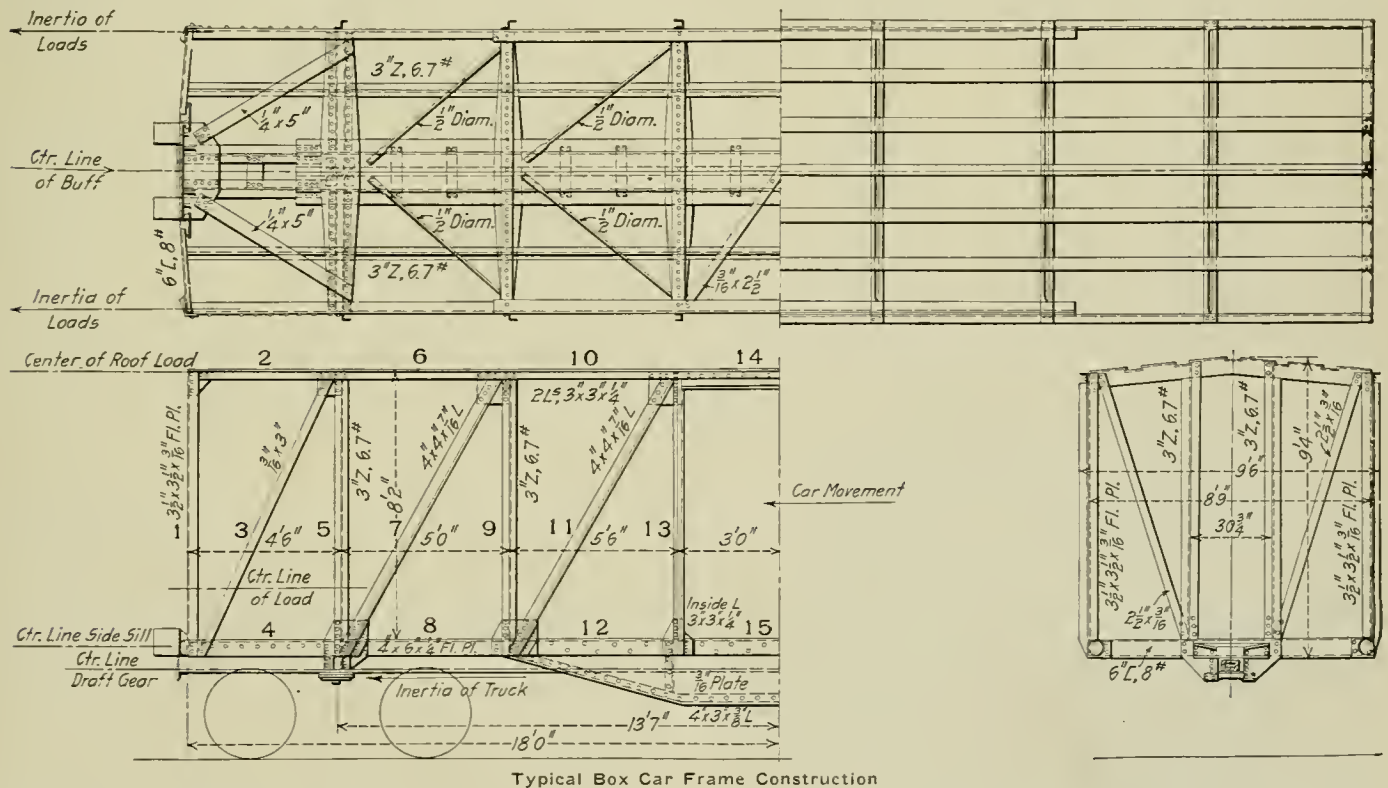

the various friction draft gears now on the market this retardation is not of a uniform nature but increases more or less rapidly as the draft gears are compressed, giving a maximum retarding force of approximately twice the mean. Based upon this assumption, where

- $V_1$  = Speed of approaching car in miles per hour,
- $V_2$  = Speed of car after impact,
- $S$  = Distance in feet in which speed is checked,
- $f$  = The average retardation in space  $S$ , in ft. per sec., per sec.,
- $P$  = Average retarding force acting on  $W$  pounds of moving weight,
- $g$  = Acceleration due to gravity = 32.2,

as subject to two loads: (1) Static load, due to its own weight plus the weight of lading, acting vertically downward; and (2) dynamic load, due to the inertia of the various parts making up the car body and lading, acting horizontally. The maximum stress in each member of the car framing is the resultant of these two loads.

In order to make proper distribution of the static and inertia loads it is essential that the weights of the various parts or members of the moving body be determined either by estimate or actual weight. Since analyses of this nature

are generally made in the preparation of new designs, the greater portion of the weights can be considered as estimated. While the following discussion is general in nature and may be applied in principle to any type of box car construction, a type of box car now in service, the construction of which is shown in the drawing, has been chosen for the purposes of illustration. This car has a capacity of 80,000 lb. and weighs light, 39,000 lb. The following table gives the dimensions of the car body and an estimated analysis of weight distribution:

Trucks (cast steel side frame).....	15,000 lb.
Underframe, flooring and brake rigging.....	9,600 lb.
Side framing and sheathing.....	7,700 lb.
Roof framing and roofing.....	4,200 lb.
End framing and sheathing.....	1,400 lb.
L = length of car body in inches.....	432
b = width of car body in inches.....	102
h = height of car body in inches.....	100
W <sub>r</sub> = average weight of roofing and roof framing per sq. ft. (taken at 14 lb.).	
W <sub>s</sub> = average weight of side frame and sheathing per sq. ft.	
W <sub>e</sub> = average weight of end frame and sheathing per sq. ft.	
N <sub>r</sub> = number of roof panels.	

ROOF

*Static or Vertical Load Stresses.*—That portion of car body weight shown as roof load can be considered as borne directly by the purline members and transferred to the side frame top chord member through the carlines. For simplification the total roof load to the carlines can be considered as uniformly distributed over the carline length and for all except the end carlines can be placed equal to

$$\frac{W_r \times b \times L}{N_r \times 144} = \frac{\text{Total roof load}}{\text{Number of roof panels}} = \text{Roof panel load} = P_r$$

resulting in a maximum vertical bending moment at the center of the carline of

$$P_r \times \frac{b}{8} = M_{rv} \tag{6}$$

The corresponding fibre stress in the carline will be equal to

$$S_{rv} = \frac{M_{rv}}{Z_v} \tag{7}$$

where  $Z_v$  = the section modulus with neutral axis horizontal.

The shear in the carline member at the side frame is given as

$$S_{srv} = P_r \div (2 \times \text{net area of carline}) \tag{8}$$

Where the end framing extends from the underframe to the end carline, the vertical bending in the end carline or end plate can be considered as resisted by the vertical end members through their column action. In some box car designs adapted to automobile service the end carline or end plate at the door end of the car must be considered as unsupported in the center against vertical bending, in which case the maximum fibre stress due to vertical bending is

$$S_{rv}^1 = \frac{P_r \times b}{16} \div Z_v \tag{9}$$

and the corresponding shear at side frame connection is

$$S_{srv}^1 = P_r \div (4 \times \text{net area of end carline}) \tag{10}$$

*Inertia or Horizontal Load Stresses.*—From equation (5) it can be seen that the inertia load bears a definite ratio to the static load and it is evident that the section modulus resisting horizontal bending in the carlines must be  $K$  times that resisting vertical bending. The stress in carlines resulting from the inertia load is therefore

$$S_{rv} = K \frac{M_{rv}}{Z_h} \tag{7a}$$

where  $Z_h$  = the section modulus resisting bending with neutral axis vertical. The corresponding shear at the side frame connection due to this inertia load is

$$S_{srh} = K \frac{P_r}{2 \times \text{net area of carline}} \tag{8a}$$

Likewise the fibre stress in the end carline member due to inertia is

$$S_{rh}^1 = \frac{K P_r \times b}{16} \div Z_h \tag{9a}$$

and the shear at side frame connection

$$S_{srh}^1 = K \frac{P_r}{4 \times \text{net area of end carline}} \tag{10a}$$

Whereby upon combining (7) and (7a) the maximum fibre stress in the carline is found to be

$$S_{r \max} = S_{rh} + S_{rv} = M_{rv} \left( \frac{1}{Z_v} + \frac{K}{Z_h} \right) = \frac{P_r \times b}{8} \left( \frac{1}{Z_v} + \frac{K}{Z_h} \right) \tag{11}$$

If the carline connection to the side rail be of a gusset type, then under horizontal inertia loads the fibre stress in the carline due to the inertia of the roof load is

$$S_{rv} = \frac{K M_{rv}}{1.5} \div Z_h \tag{7b}$$

and the maximum combined fibre stress due to the static and inertia loads is

$$S_{r \max} = M_{rv} \left( \frac{0.67 K}{Z_h} + \frac{1}{Z_v} \right) \tag{11a}$$

The maximum shear corresponding to the above maximum bending moment is

$$S_{sr \max} = \sqrt{(S_{srv})^2 + (S_{srh})^2} = \left[ \frac{P_r}{2 \times \text{net area of carline}} \right] \times \sqrt{1 + (K)^2} \tag{12}$$

The maximum stresses in the end plate are given in connection with those for end framing.

Equations (7) and (7a) can also be employed to advantage in determining the necessary minimum section modulus which would give a predetermined maximum fibre stress in carline members, since the summated section moduli of all roof carlines can be considered as supporting or resisting the total roof bending moment or

$$\sum Z_v \times S_v = \frac{P_r \times N_r \times h}{8} \tag{13}$$

$$\text{and } \sum Z_h \times S_h = K \left( \frac{P_r \times N_r \times b}{8} \right) \tag{14}$$

and if it be further desired that  $Sh = Sv$ , or  $Sh = S_{max} \div 2$ ; and  $S_{max} = 24,000$  lb. per sq. in., then

$$K \times \sum Z_v = \sum Z_h$$

and substituting for  $P_r$  its value in terms of unit weight of roof

$$\sum Z_v = \frac{W_r \times b^2 \times L}{13,824,000} \tag{15}$$

The total section modulus of carlines resisting vertical bending per 100 sq. ft. of roof area is

$$\frac{\sum Z_v}{100 \text{ sq. ft.}} = \frac{W_r \times b}{960} \tag{16}$$

Substituting for  $b$  its value of 102 in. and for  $W_r$  a value of 14.0 lb. per sq. ft. (16) then becomes

$$\frac{\sum Z_v}{100 \text{ sq. ft.}} = 1.5 \text{ in.}^3 \tag{17}$$

$$\text{and } \frac{\sum Z_h}{100 \text{ sq. ft.}} = K \times 1.5 \text{ in.}^3 \tag{18}$$

From equations (4) and (5) the value of the constant  $K$  was determined as approximately 13.5. Substituting this value

$$\frac{\sum Z_h}{100 \text{ sq. ft.}} = 20.25 \text{ in.}^3 \tag{18a}$$

If the carlines be secured to the plates with gusset connections (18a) becomes

$$\frac{\sum Z_h}{100 \text{ sq. ft.}} = 13.5 \text{ in.}^3 \tag{18b}$$

The total section modulus of roof carlines to resist vertical bending should be 1.5 in.<sup>3</sup> about the horizontal axis and 20.25 in.<sup>3</sup> about the vertical axis for each 100 sq. ft. of roof area.

END FRAME

*Static Load Stresses.*—The column load stresses in the end frame members due to the weight of end framing and sheathing are usually so small compared with the total stress due to end pressure of lading itself as to be safely omitted. The chief function of the end framing is to prevent distortion of the car body by end pressure or the bulging action of the

loading when shifting under sudden changes in the speed.

This pressure considered as acting horizontally and tending to bend the frame members outward, increases with the depth of load and at any height  $h$  the total lateral load is

$$E = \frac{1/2 w h^2 b \tan^2 (45 - \phi/2)^*}{1728}$$

- where  $E$  = Total pressure.
- $\phi$  = Angle of repose of commodity.
- $\theta$  =  $1/2 (90 - \phi)$
- $h_1$  = Height of grain or coal in car in inches.
- $w$  = Weight of commodity per cu. ft.
- $b$  = Width of load or car in inches.

Under conditions of actual operation the height of the load at the ends of the car may approach the value of  $h$  (inside height of the car) and for maximum conditions  $h$  may be substituted for  $h_1$ . The total end pressure then becomes

$$E = \frac{w h^2 b \tan^2 \theta}{3456} \dots \dots \dots (19)$$

and the end frame members present the case of a beam, either fixed or supported at both ends, with a load varying uniformly from zero at one end to a maximum at the other. Considering the ends as supported, the maximum bending moment is

$$M_e = \frac{2 E h}{9 \sqrt{3}}$$

Substituting for  $E$  its value from equation (19),

$$M_e = \frac{w h^3 b \tan^2 \theta}{1728 \times 9 \times \sqrt{3}}, \text{ or}$$

$$M_e = .000037 w h^3 b \tan^2 \theta \dots \dots \dots (20)$$

Further if it be required that 75 per cent of this total endwise bending moment be resisted by the end reinforcement members and the remaining 25 per cent be taken up by the body corner posts, then

$$M_e \text{ reinforcement members} = .75 M_{max} = .000028 w h^3 b \tan^2 \theta \dots (21)$$

$$\text{and } M_e \text{ corner posts} = .25 M_{max} = .000009 w h^3 b \tan^2 \theta \dots \dots \dots (22)$$

Where the design of car framing is such that vertical members are connected to the under-frame and to top rails in such a manner as to be equivalent to the conditions of beams having ends fixed or rigidly connected, it is possible to use lighter sections for resisting the bulging action. Under these conditions the total maximum bending moment in the end frame members under static load is

$$M'_e = \frac{.0395 w h^3 b \tan^2 \theta}{3456} = .0000114 w h^3 b \tan^2 \theta \dots \dots \dots (20a)$$

at a point  $.423h$  above the floor. Another maximum will be found at the top and bottom connections, the value of which will be

$$M''_e = \frac{.0889 w h^3 b \tan^2 \theta}{3456} = .0000257 w h^3 b \tan^2 \theta \dots \dots \dots (20b)$$

If the same division of the load between the end reinforcement members and the corner posts is used as before, the corresponding moments are

$$M'_e \text{ reinforcement members} = .75 M'_e = .00000855 w h^3 b \tan^2 \theta \dots (21a)$$

$$M''_e \text{ reinforcement members} = .75 M''_e = .0000193 w h^3 b \tan^2 \theta \dots (21b)$$

which occur at a point  $.423h$  above the floor and at the top and bottom connections respectively. Similarly, the values for the corner posts are

$$M'_e \text{ corner posts} = .25 M'_e = .00000285 w h^3 b \tan^2 \theta \dots \dots \dots (22a)$$

$$M''_e \text{ corner posts} = .25 M''_e = .0000064 w h^3 b \tan^2 \theta \dots \dots \dots (22b)$$

**Inertia Load Stresses.**—Under the effect of sudden changes in speed the endwise pressure would tend to vary and the normal static angle of repose would be found greatly to exceed the angle of repose when the commodity is further influenced by inertia.

The writer has been unable to learn of any experiments or tests which have been made with a view towards locating the resultant angle of repose in such cases or towards determining the exact endwise pressure. It is believed, however, that a safe assumption would be to consider the endwise pressure as due to a volume of commodity back of the wall

equal to the wedge of height  $h$  and angle at lower edge equal to  $(90 - \theta)$  or approximately twice the wedge considered in static equilibrium. Then the expression for total endwise pressure due to inertia is

$$E_i = K \left( \frac{w h^2 h \tan^2 \theta}{1728} \right) \dots \dots \dots (23)$$

and the corresponding bending moment in end frame members due to inertia can be shown from formula (20)

$$M_{e,i} = 2 K M_e = .000074 K w h^3 b \tan^2 \theta$$

whereupon by substituting value of  $K$  from equation (4)

$$M_{e,i} = .001 w h^3 b \tan^2 \theta \dots \dots \dots (24)$$

With the end frame members sustaining bending moments equal to 75 per cent total maximum end bending moment the requisite section moduli of these sections becomes

$$\Sigma Z_{e,i} = \frac{.75 M_{e,i}}{S}$$

Substituting the following numerical values:  $w=60$  lb.;  $h=72$  in.;  $b=102$  in.;  $\theta=30$  deg.,

$$\Sigma Z \text{ reinforcement members} = \frac{.00075 \times 60 \times 72^3 \times 102}{20,000 \times 3} = 28.6 \text{ in.}^3$$

at a height of 24 in. above the floor.

Based upon vertical end reinforcements fixed or rigidly connected at the ends, the required section modulus for uniform section is given as

$$\Sigma Z \text{ reinforcement members} = \frac{.75 M'_{e,i}}{S}$$

$$M'_{e,i} = 2 K M'_e = 2 \times 13.5 \times .0000257 w h^3 b \tan^2 \theta$$

$$M'_{e,i} = .000694 w h^3 b \tan^2 \theta$$

Substituting the numerical values used in the previous case.

$$\Sigma Z \text{ reinforced members} = \frac{.75 \times .000694 \times 60 \times 72^3 \times 102}{20,000 \times 3} = 19.8 \text{ in.}^3$$

(To be continued.)

### INTERLOCKING FENDERS AND COLLISION BUFFERS

The problem of minimizing the effect of collisions and to provide, if not immunity from telescoping, at least something nearly approaching it, has exercised the minds of British railway engineers and experts for many years past; but the



The Interlocking Fenders as They Appear on the End of a Car

\*From Rankine's formula for the pressure of earth against retaining walls.

necessity for further safeguards has been emphasized by the more recent accidents, involving loss of life and destruction of property. With the introduction of rolling stock of a much heavier character, the danger has naturally been increased.

What is required is a buffing and interlocking arrangement whereby, when the shock of collision comes, the underframes of cars may be prevented from getting out of alignment. The patent anti-collision buffers and interlocking buffer fenders recently fitted to one of the London and Man-

chester express trains on the Great Central Railway by J. G. Robinson, chief mechanical engineer, appear to be an advance in the direction indicated so far as British practice is concerned.

It is not claimed that this invention will render telescoping of cars entirely a thing of the past, because the amount of weight in a collision varies in every instance, and in some cases the impact to be contended with is so great that it would be difficult to devise any means of withstanding it. The new collision buffers have a reserve stroke of 30 (long)

as possible over each buffer. These are rights and lefts, and are so arranged that they interlock when the buffers are driven home, broken or put out of action. The importance of this arrangement will be readily seen, for the very act of interlocking when the buffer is forced out of action prevents the underframe from rising or mounting. These fenders are formed of corrugated steel plates in three layers placed alternately and bolted together, being secured by angles on the endsill and the end of the body. They absorb a portion of the impact, thus preventing the underframes from telescoping

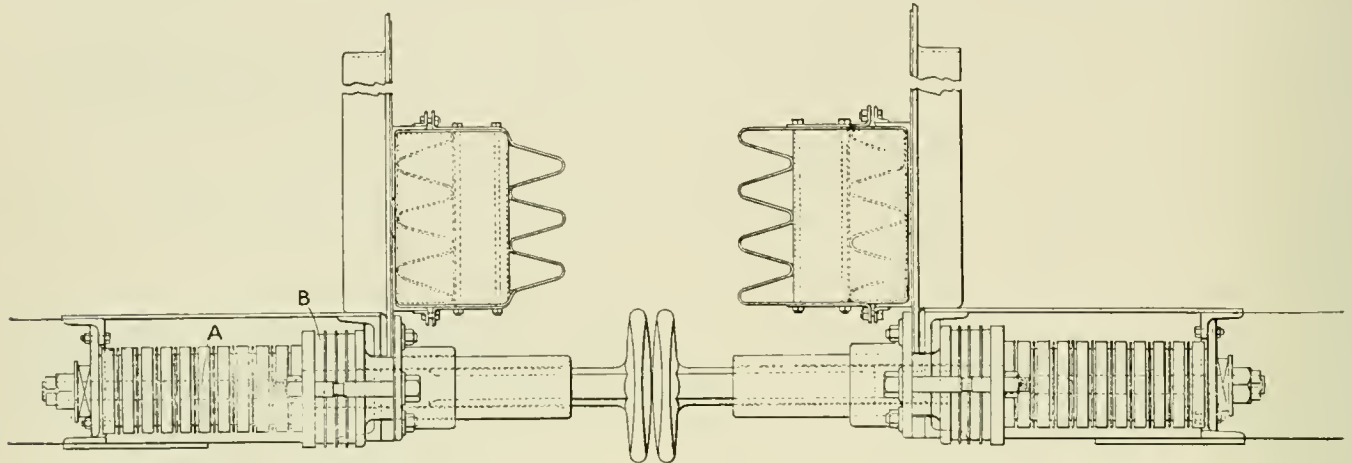

Collision Fenders, Showing Ordinary Buffer Spring A and Reserve Stroke Buffer Spring B, in Normal Position

It is not claimed that this invention will render telescoping of cars entirely a thing of the past, because the amount of weight in a collision varies in every instance, and in some cases the impact to be contended with is so great that it would be difficult to devise any means of withstanding it. The new collision buffers have a reserve stroke of 30 (long)

as possible over each buffer. These are rights and lefts, and are so arranged that they interlock when the buffers are driven home, broken or put out of action. The importance of this arrangement will be readily seen, for the very act of interlocking when the buffer is forced out of action prevents the underframe from rising or mounting. These fenders are formed of corrugated steel plates in three layers placed alternately and bolted together, being secured by angles on the endsill and the end of the body. They absorb a portion of the impact, thus preventing the underframes from telescoping

as possible over each buffer. These are rights and lefts, and are so arranged that they interlock when the buffers are driven home, broken or put out of action. The importance of this arrangement will be readily seen, for the very act of interlocking when the buffer is forced out of action prevents the underframe from rising or mounting. These fenders are formed of corrugated steel plates in three layers placed alternately and bolted together, being secured by angles on the endsill and the end of the body. They absorb a portion of the impact, thus preventing the underframes from telescoping

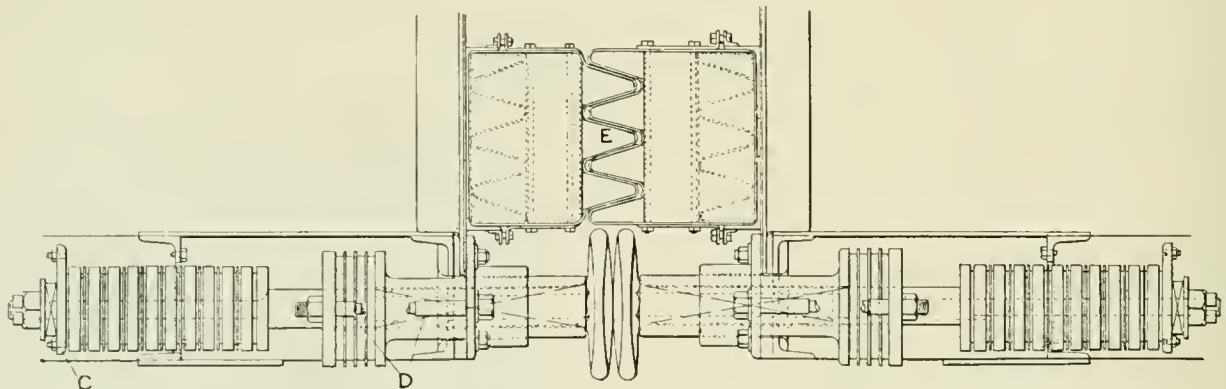

Collision Fenders, E, interlocked; Resisting Bolts C of Ordinary Buffers and D of Reserve Stroke Buffers Broken

tons, and will not collapse under a pressure less than 100 tons exerted at the ends of each car. Even then there are the collision fenders to offer further resistance and to materially help to absorb the force of the collision.

One of the difficulties to be overcome was the tendency for underframes to mount or override one another. In order to prevent this, as far as possible, the interlocking fender is introduced, with the result that the lateral alignment is preserved to a far greater extent than heretofore, the natural consequence being that a much heavier shock can be absorbed by the corrugated collision fenders.

While, however, the interlocking fenders work against the underframes mounting one another, it was felt advisable that

the bodies. The Metropolitan Carriage, Wagon & Finance Company, Ltd., of Saltley, Birmingham, are the sole licensees.

**WEIGHT OF WROUGHT IRON.**—The average weight of wrought iron is 480 lb. per cu. ft., or a bar 1 in. square section and 3 ft. long (36 cu. in.) weighs 10 lb. Therefore, to find the sectional area of a bar of uniform size throughout its length regardless of its shape, multiply the weight per foot by 3 and divide by ten (3/10). Example: An I-beam 4 ft. long weighs 72 lb. What is its sectional area in square inches?  $72 \div 4 = 18$  lb. per foot.  $18 \times 3/10 = 5.4$  sq. in. sectional area.—Power.

# Shop Practice

## TESTING PNEUMATIC TOOLS

BY J. D. SMITH

Enginehouse Foreman, Philadelphia & Reading, South Bethlehem, Pa.

In a large shop where many air tools, such as chipping and riveting hammers, are constantly in service, it is a matter of economy that these tools be kept free from excessive leaks and worn parts. Hammers may be inspected once a week and given a thorough oiling, tested and found to strike an apparently hard blow, yet they may be leaking around their moving parts to such an extent that their efficiency is decreased considerably. In the absence of some means of testing and measuring the leakage, however, they are allowed to

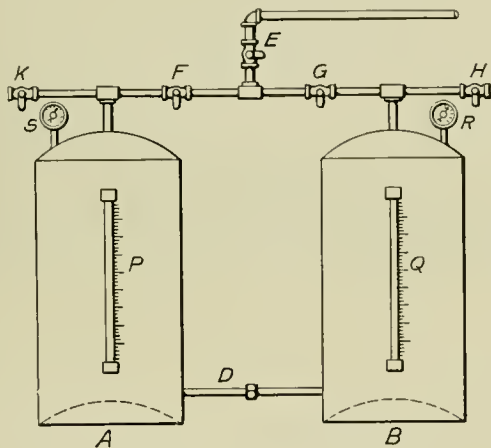

Equipment for Determining Air Consumption of Pneumatic Hammers

remain in service until they cannot be made to do the work. A hammer with a leaky valve or leaks around the piston or chisel bushing, will not do the work as quickly as a tight hammer with the results that the labor cost is greater than it should be and that the cost of compressing the air is increased to supply the leakage. These losses are proportional to the condition of the hammer and for a single tool may not amount to much, but where a great many such leaky tools are in service, the aggregate is considerable.

The condition of air hammers can be determined with ease and accuracy by means of a testing plant such as is outlined in Fig. 1. Two tanks *A* and *B* of  $\frac{3}{8}$ -in. plate about 40 in. in diameter by 72 in. high, are connected by a 2-in pipe *D* at the bottom. These tanks are each filled half full of water when set up. They are fitted with water columns *P* and *Q*, so that the water level in each may be ascertained. Air from a pressure line enters through valve *E* and flows through valves *F* and *G* into the tanks.

To determine the air consumption of a tool attach one end of a hose to cock *H* and the other end to the tool. Open valves *E*, *F* and *G*, and close valves *K* and *H* until the pressure in each tank is up to the desired test pressure. Then close all valves. At a given instant when the test is to begin, open valves *E* and *H*, allowing air to flow from tank *B* into the tool. Then open valve *F* enough to allow sufficient air to flow from the supply line into tank *A* to displace the water

from *A* to *B* and force air from tank *B* into the tool at constant pressure. When the test is completed quickly close valves *H* and *F*. The water levels will not change as the air pressure will not allow the water to rise in *A*. By taking the time between the opening and closing of valve *H* and measuring the rise of the water in tank *B*, knowing the inside diameter of the tank, the volume of compressed air used per minute can be calculated. From this the equivalent cubic feet of free air per minute is obtained. When tank *B* is filled with water, tank *A* can be used, the hose being attached to cock *K* and the process reversed. The graduations on the tanks back of the water columns may be in fractions of a cubic foot of tank volume, thus facilitating the work by doing away with the measurement of the rise of water level with a foot rule. By this means a tool may be tested at any air pressure, limited only by the pressure on the air line, and its equivalent free air consumption calculated.

For example, a chipping hammer was tested for two minutes at 90 lb. gage pressure, and the rise of the water level was 10 in. Assuming that the inside diameter of the tank was 42 in., the equivalent cubic feet of free air consumed per minute was:

$$\frac{3.1416 \times 21^2 \times 10 \times (90 + 14.7)}{1728 \times 2 \times 14.7} = 28.5.$$

To test the hammer insert a blank set and allow it to operate against a block of wood, care being taken to hold the hammer up against the set in the same manner as when chipping or doing other work. Three or four of these tests should be made, of about one minute duration, from which the equivalent free air consumptions can be calculated and averaged. A standard equivalent free air consumption for each size and make of hammer can be set by thoroughly testing new hammers and taking the average of several tests.

To show the increased air consumption of a hammer in

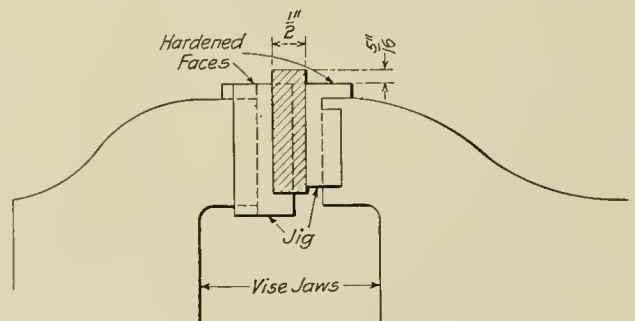

Jig Used in Testing Pneumatic Chipping Hammers

fair condition over a new hammer, a few used hammers apparently giving good service were selected for test at random from the supply at a large shop. Another practically new hammer of the same size and make was selected and tested along with the old hammers. At 80 lb. pressure it was found that the old hammers consumed on an average of 12 per cent more free air per minute than the new one. At 90 lb. pressure the increased air consumption of the old hammers averaged 15.6 per cent.

When it is desired to test the strength of a new hammer

in comparison with one of the same size, but of a different make, a chipping test may be made. A piece of  $\frac{1}{2}$ -in. boiler plate about  $6\frac{1}{2}$  in. long is put into a special chuck (see Fig. 2), made to fit the jaws of a vise and the chuck then clamped in the vise. The plate should be placed so that 5-16 in. extends above the top faces of the chuck, which are hardened to form a guide and bearing for the chisel. The test consists in taking a 5-16 in. cut off of the boiler plate. A man experienced in operating a chipping hammer should be selected to make the test. The cut should be started flush with the top faces of the chuck and extended for about  $\frac{1}{8}$  in. From this point a distance of 6 in. is laid off as the length of the cut. At a given instant the cut is started and run the entire 6 in. without stopping. The chisel should be sharp and the cutting edge should be oiled as the cut advances. A good chipper can easily take this cut without stopping. The time required to make the cut is noted and the free air consumption calculated. Three of these tests at 90 lb. pressure, when carefully made, are sufficient to show the strength of a hammer.

A testing plant of this kind is also useful in determining the free air consumption of other air tools, such as air motors, the horsepower output of which can be measured at the same time with a Prony brake; boiler tube cleaners, and others. It is easy to operate, has no parts that will wear out quickly, and if the measurements are taken carefully, accurate results can be obtained. The apparatus can easily be made in any large shop.

## PROCRASTINATION, THE THIEF OF TIME

BY F. A. WHITAKER

Procrastination has caused the downfall of many a good mechanical officer. If he had used good judgment and done the work on his engines when they required it and not tried to show how quickly he could turn an engine and furnish it to the transportation officers, the new laws governing the inspection of locomotives would never have been. The Government has only said what shall be done; and, by the way, the Government is only asking to have done what should have been done all the time. Consider any of the requirements of the new law, and no one who is a mechanic can say there is anything there that is unnecessary both from a maintenance standpoint and "safety first." The fixed standards arrived at by the Interstate Commerce Commission are not as high as some of the standards already in use on a good many railroads at the time the law went into effect, but like a good many standards they were subject to diversions and were carried out to suit the particular time and place. Under the new laws the mechanical officer is protected in doing the necessary work at the necessary time; no procrastinating goes if he wants to stay on the job and live peacefully.

The author believes that these laws are the best that have ever been promulgated for the mechanical officer, and if our mechanical men will only realize that they are already in effect and get down to business in regard to carrying out the instructions, the railway companies and themselves will be better off 12 months from now than they are at the present time. A lot of mechanical officers are under the impression that if they can get their engines by the Interstate Commerce Commission inspectors everything is all right; but the man who thinks this is either in the wrong place or deceiving himself. Any good roundhouse foreman knows the condition of his engines, and if he has the proper support from those above him should be able to keep his engines within the law's requirements. The author has found through personal contact with the inspectors that any foreman who shows any inclination to carry out the law receives every consideration from them, and besides it is the railroad company's business to inspect and repair all defects regard-

less of whether the inspectors find them or not. The foreman who only keeps his engines in shape when he is expecting the inspector is bound to get caught and after he does he is a marked man.

As regards the railway company's inspection, some of us are criticised because we are not careful enough; our inspectors are not as alert and observant as they might be. My personal experience has been that if we had more men to do the work and fewer inspectors we would be better off. It is not the lack of inspectors nor the closeness of the inspection; it is the lack of men, time and material to do the work that has been found by the inspectors. Not every foreman has the backbone to say that the work found by the inspectors shall be done before the engine leaves the terminal, and if we are going to inspect engines for defects and find them and then not repair them what is the good of inspecting? The only solution, it would seem, is that when necessary work is found and reported the foreman must have the work done, regardless of the time the engine is wanted, before it is allowed to leave. This, of course, will result in more talk and argument with yardmasters, train dispatchers, etc.; but it should be noted that when the Interstate Commerce Commission inspectors serve Form 5, the work is then done, and it should be distinctly understood by all concerned that no engine should be continued in service with any defects regardless of how badly the engine is wanted. No man can build up an organization on procrastination and when you are tempted to let work go by today because you haven't time, remember that tomorrow you may have less.

## A<sup>2</sup> SIMPLE GREASE CUP PLUG

BY JOHN P. RISQUE

Mechanical Engineer, United Railways of Havana, Havana, Cuba

The drawing shows the standard grease cup and plug of the United Railways of Havana. There is nothing unusual about the cup, and the only novelty about the plug is the square lug which is cast on the bottom. The function of this plug is to imbed itself in the hard grease, where it acts

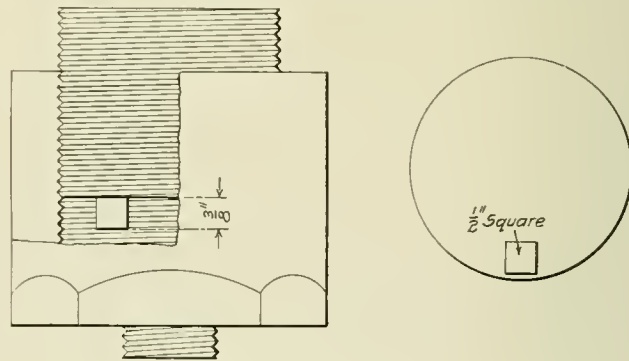

A Grease Cup Plug Designed to Lock in the Grease

as a lock, the grease keeping it from turning and consequently from unscrewing and loosing out of the cup. No lock nut is used with this plug. It simply screws into the grease, and stays there until somebody unscrews it.

**MORE RAPID STEAMING WITH SMALLER SIZES OF COAL.**—With a given size of furnace and draft sufficient for equally perfect combustion, the smaller sizes of coal will become burned and will generate steam more rapidly than the larger sizes. The more finely divided the more promptly are the combustible elements of the fuel raised to the temperature of combustion and sooner brought in contact with the oxygen of the air supply, resulting in more rapid combustion and a quicker liberation of heat than from combustion of larger sizes of coal.—*Power.*



# TRAINING BOILERMAKER APPRENTICES



Discussion of Some of the Peculiar Problems Which Confront the Instructors in Charge of This Work

*Instructing Boilermaker Apprentice in Laying Out Work*

**D**EVELOPING and training locomotive boilermaker apprentices is no easy task. This subject, with that of training freight car carpenter apprentices, took up most of the time at the annual meeting of the Santa Fe apprentice instructors which was held at Topeka, Kan., May 25-27. An account of the general features of this conference appeared in the *Railway Mechanical Engineer* of July, page 363.

George Austin, general boiler inspector of the Santa Fe, attended the meetings during the time this subject was being discussed, and gave the men splendid ideas as to the training of the boilermaker apprentices. He went through the book of rules for boiler inspection published by the Santa Fe, and pointed out those features which should be most carefully watched both in the shops and during inspection. Not only were the rules themselves discussed, but also the best means of imparting the information to the boy. Ability to *apply* the rules is what counts, not mere familiarity with the wording of the rule. Interest was added to this discussion by stereopticon views, and by samples of properly and improperly applied patches and flues. The Santa Fe now has four boilermaker apprentice instructors, these men having no other duties than to instruct and train the apprentice boys of the boiler shops.

Mr. Austin brought out a number of important points which he had found in his experience as general boiler inspector to be sources of considerable trouble. He explained the proper method of applying patch-bolt patches, copper ferrules in tube sheets, and believed that the boys should be given some instruction on the proper maintenance of boilers, such as might be learned in a roundhouse. He also pointed out that considerable is to be learned from the "scrap

pile." Many defects caused by improper work will be seen there and will serve to caution the boys against doing their work improperly. He strongly advocated that the boys be given thorough instruction on inspection, suggesting various points which should be carefully watched.

The instructors also had an opportunity of asking questions from the representative of the mechanical engineer's office who handles the calculations for the factor of safety of boilers and the efficiency of boiler seams.

## WHAT ASSISTANCE SHOULD BOILER SHOP INSTRUCTOR GIVE APPRENTICES?

F. C. Reinhardt, apprentice instructor in the boiler shop at Cleburne, Tex., presided. The boiler shop instructors agreed that the instructors should not only tell a boy how to do the work correctly, but should actually show him how to do it. First explain the job to be done; that is, what is to be accomplished, the purpose and the place used. Then show or demonstrate enough to give a correct idea both as to handling the tools and going ahead with the work. There is not much danger of showing too much, but the instructor should not try to do all the work for an apprentice. He should watch the work until sure that the boy can do it satisfactorily. Strive at all times to gain and keep the confidence of the boys. Study each individual and handle accordingly. There is a great deal of difference between boys even in the same shop. They cannot be handled alike. Some will need more demonstrating than others. It was also pointed out that the instructor should mix with the boys and be one of them. He should be prepared at all times to take hold and help the apprentices. This will result in their doing more and better work. It will take more time at first, but will save much

time later on. It was suggested that foremen in distributing work among the apprentices should notify the instructor when they put a boy on a new class of work, in order that the instructor may see that the boy is properly started.

#### HOW TO TEACH LAYING OUT

Arthur Moon, apprentice instructor in the boiler shop at Albuquerque, New Mex., presided. In teaching laying out, the first steps should be taken in the school room where drawings of the objects are made to scale, developed, cut out and assembled. The first laying out jobs in the shop should be closely supervised by the instructor. The apprentice should follow the laying out job to completion. Blue prints should be carefully studied and thoroughly understood before beginning the work upon the plate. The importance of properly squaring up a sheet was brought out. Apprentices should have experience on all of the laying out jobs done in the boiler shop. The apprentice should start with the light sheet metal work and later work on the heavier grades. After the boy demonstrates his ability he should be left to his own resources, but the work should be checked by the instructor and any errors pointed out and corrected. Work of this nature should be given to third and fourth year boys only. Whenever possible, apprentices should fit up the work they lay out. Special school room problems are now in preparation to go with this work.

#### APPRENTICES AND SPECIAL WORK

Charles Schmidt, apprentice instructor in the boiler shop at San Bernardino, Cal., acted as chairman. The apprentices should not be worked with handymen, but with journeymen, and should not be used as helpers merely to carry tools. Some of the boilermakers do not explain work to an apprentice, consequently the shop instructor should do so. It is as much the duty of the shop instructor to see that the apprentice is given the various classes of work as it is to assist him after the work is assigned. The management intends that the instructors shall be held personally responsible for this. The best method of giving a boy work done by a special man is, so far as possible, to have the boy placed with the man doing the work. It seems that at some points, especially the smaller places, the boys have not been getting much of this class of work. This may be due to the fact that there is only about enough to keep one man engaged, and if an apprentice is placed with the man, it will lower the man's efficiency, as two men's time will be charged, when it is only one man's job. In this connection, J. Purcell, assistant to the vice-president, said that he wished all of the boilermaker apprentices to be given some of this special work. It will be necessary for the apprentice instructor to watch for an opportunity and then use the boy. This is particularly true with staybolt testing, hydrostatic tests, etc.

Mr. Purcell's idea for training apprentices for inspecting staybolts was to have the apprentice go over the staybolts of a firebox while the engine is on the hospital track, and mark on the standard form each staybolt he thought to be fractured or broken; this, in addition to the regular report made out by the staybolt inspector. After the firebox is cut out or the marked bolts are removed, have the apprentice go over his report and notice if the staybolts he had marked are the ones fractured or broken. In this way he can learn to distinguish fractured and broken staybolts by sound.

#### WORK FOR TRANSFERRED APPRENTICES

J. H. Lewis, apprentice instructor in the boiler shop at Topeka, Kan., acted as chairman. Certain classes of work are not performed in the smaller shops, and other work is not done at the larger shops. To remedy this the instructors agreed that each boilermaker apprentice should be transferred sometime during his apprenticeship, preferably during his sixth or seventh six months' period, so that he may get the

various classes of work offered in both the larger and smaller shops. Apprentices should be transferred from the smaller to the larger shops to get laying out, patch welding, flanging, flue sheets, door sheets, fitting up new work, etc., and any other work that is not done in the smaller shop. Apprentices should be transferred from the larger to the smaller shops to get roundhouse experience, running repairs, hot work, front ends, patch bolt patches, etc. Mr. Purcell said the instructors should see to it that the boys *did* get *all* the different kinds of work. In connection with this the following schedules of work were adopted:

#### FROM LARGER TO SMALLER SHOP OR ROUNDHOUSE

6 weeks grates and hot work.  
6 weeks patch bolt patches and hand riveting.  
6 weeks staybolts and plugging cracks.  
4 weeks inspecting, hydrostatic tests and staybolt tests.  
4 weeks front ends and ash pans.

#### FROM SMALLER TO LARGER SHOPS

6 weeks flue and door sheets and welded patches.  
6 weeks fitting up new work.  
6 weeks laying out.  
2 weeks flange fire.  
4 weeks radial stays.  
4 weeks driving staybolts and radial stays.  
4 weeks gas welding.  
4 weeks inspecting, testing, etc.  
2 weeks welding and swedging flues.  
2 weeks flues.

Also, if possible, keep him for a year, giving him the remainder of the time on general boiler work.

#### ADDITIONAL SCHOOL WORK

G. T. Peterson, apprentice instructor at Albuquerque, New Mex., acted as chairman. The school work should harmonize



Instructing a Boilermaker Apprentice on Staybolt Work

with the shop work. Special problems pertaining to boiler work are now being prepared. In drawing, the boy should complete the regular lessons for all trades through the geometrical construction problems; then the school room work should be designed to apply more directly to boiler work. Make all of the regular laying out drawings and extra draw-

ings from blue prints such as used in the shop. The laying out work done in the school room should conform to the work the boy is on in the shop. In school the parts are laid out to scale, cut out, and pasted together. This gives each boy an opportunity of seeing for the first time how the work will appear when rolled and assembled. While on general boiler work, the boy should systematically study the Locomotive Folio (a book of Santa Fe standards), learning what it contains pertaining to boilers and subjects closely related to boiler work. In general, his work in the school should conform to what he is doing in the shop and in addition he should be required to study the folio, boiler rules, learn to calculate strength of joints, seams, patches, etc. The boiler instructors were asked to visit the school rooms during class sessions in order that they may assist in special work for the boilermaker apprentices, as this will greatly assist in correlating the school work with the needs of the boys in the shop.

**HANDLING A BIG ENGINE TERMINAL\***

BY HARVEY DE WITT WOLCOMB

So much time and study has been given in the past few years to develop better engine handling facilities at the large terminals that it is almost impossible to suggest any new ideas on this subject. Where we do find any special system, it is usually on account of some necessary local requirement or is some "hobby" of an official, and so it is not fair to hold up any one of these systems as an example for the terminals in general to pattern after. Of course, the key-note of successful enginehouse management is "system," and in many of the up-to-date roundhouses the place will almost run itself without the foreman in charge being on the job. To one who has been raised in the old-time roundhouse, where the foreman has to be a sort of magician to produce the results that are required of him, it would seem that more credit should be given the man who can produce "big results from a small terminal" than to one who can produce "results from a big terminal." Such items as the type of engine used, the tonnage hauled, the length and the grades of the division, the nature of the water used, the class of workmen employed, and the distance from the general repair shop, govern the system that is best suited and from which the best results can be secured; therefore let us consider only such things as are applicable to all roundhouses.

An organization, to be effective, must have enough foremen or gang leaders to properly cover their assigned tasks without giving too much time to small details. In other words, the foremen and workmen should each have their place and should be trained to handle their respective parts in such a manner that it would not be necessary to go into any details covering the jobs they are to do. As an example of this system, the leader of the truck repairs will be notified that an engine requires a new pair of tank wheels, and it will be his duty to get the wheels required, place the engine on the pit where the work can be handled most conveniently, and look after all the many small details that may come up in connection with this work. If this line is followed out, it will be found that the perfect system for a roundhouse handling about 90 engines a day of 24 hours will not require any great number of foremen, but can be successfully managed with the work sub-divided under gang leaders. In fact, one good, live roundhouse foreman can get along better than to have several foremen where the assignment and distribution of responsibility is so divided that in the end no one man will take the entire responsibility but will put it up to the other fellow.

In the diagram which shows the plan of organization, it will be noted that only one foreman is shown for the entire roundhouse, and in turn the gang leaders, acting as sub-foremen, report to him direct. This line-up is intended for the

medium-sized terminal, and in case it is desired to check this system against any of the large terminals, the diagram can be altered to suit these conditions by changing the title of roundhouse foreman to general roundhouse foreman, and the titles of gang leaders to assistant foremen, and still use the idea of gang leaders for all classes of work. There are many reasons for this system, chief of which is that each gang can have any special tools which might be used on their work and no time will be wasted in getting started on a rush job. Another valuable point is, that in case of any question about a job not being done properly the responsibility can quickly be placed just where it should be. Still another important point is that where the same gang is doing the same work every day they are more liable to discover some point in the equipment that can be improved so as to make their work easier, and also the study of efficiency has proved that one thing can be done better when specialized than doing several things at different times. It is a fact that the supply of "all-around" mechanics is not as plentiful as in years gone by, so it is necessary to make specialists to efficiently handle the several jobs. One other point that should be spoken of is that in an organization of this kind every man knows his place and just what is expected of him, so that if the system is well balanced the routine business will be handled without any hitch.

The weak points in equipment is a subject that has

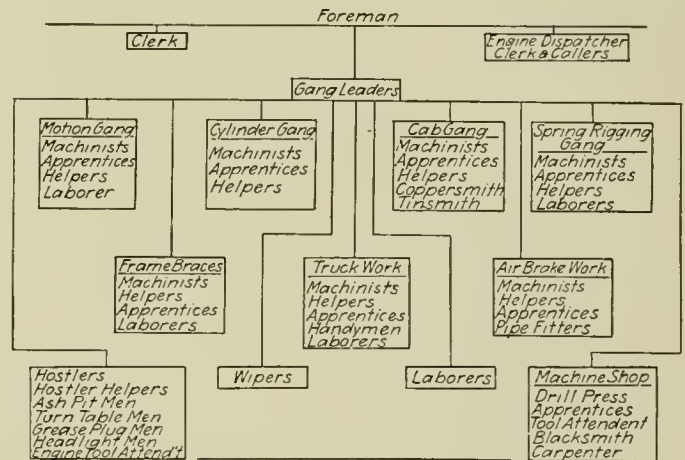

Organization of Roundhouse Forces

not been given the proper attention in the past and today we are continually meeting the necessity for costly repairs in the roundhouse, that could have been avoided. In order to prevent future trouble of this kind the roundhouse force should be constantly on the watch to report and have corrected any faults in the construction of the locomotives. Under this same heading standardization of different parts might be brought up, for the roundhouse is the place where this is the greatest source of trouble. Adopt a good standard part that will suit all classes of engines and then maintain that standard. This means less material to be carried in stock, less cost to manufacture in quantities, and no time lost when required in a hurry. Very often it is cheaper to throw away a broken part and use a standard part than it is for the roundhouse force to waste time in patching up the broken piece. Work in a roundhouse is handled under so many handicaps that it is the most expensive and therefore should be confined as much as possible to simply renewing worn-out parts or patching broken parts when absolutely necessary. On the other hand, it is also very expensive to steal parts from one engine for another, so if standard parts are carried in stock, and can be used, the cost of running repairs will soon prove that the system is economical.

Substituting cast steel castings for brass castings and forgings will not only reduce the cost of maintenance but will

\*Entered in the Engine Terminal Competition.

also give such better service that the parts will not require as much attention and repairs.

The real secret of successful roundhouse operation is the loyalty of the men, and cutting out any lost motion that might result in delays. At a point where even minutes wasted means a possible failure, it does not pay to have one gang rush after their part of the work and get it done in record time and then have some other gang waste so much time that the engine gets behind on its schedule. As a rule, this happens in nearly every place, for an engine will be delayed on the ashpit for over an hour, and then when it gets in the house the spring rigging gang will be asked to perform some record work so as to get it out again on time. So that the first and one of the most important parts of the organization is the ashpit, which should be under the supervision of a head hostler. This head hostler should be the best that can be secured, and should receive high wages, for on him depends the length of time that it takes to get an engine in the house after it reaches the terminal. The best man on this job is none too good, and he should receive all encouragement in his work. We all know that when a terminal gets "tied up" during a heavy storm, the greatest trouble is generally at the ashpit; and the time that can be saved at this point will give more time in the house for inspection and repairs.

Each class of engine should have a printed list of special points that are to be looked after or checked up at the boiler washing period. This list should be made to include the regular boiler washing records, and when the engine is completed the list should be signed by the leader in charge and the names of the men working on the job with him. The main idea of this list is to take care of any weakness in a part that is liable to cause a failure, but it can also include the inspection of any part that is under test. Some roads have a regular printed list of jobs that must be looked after at this time, but the better plan is to have a list made out separately to cover each specific class of engine, for on some engines there are points to be checked up that the other engines do not have.

The roundhouse foreman should have time to study his surroundings so as to change his organization if conditions demand it. He must watch his different gangs to see that one gang is not working short handed or that another gang has too many men. He must also keep in touch with the enginemen and find out anything they want done, for the successful foreman is not the one who slights his work, but who tries to do all in his power to keep the engines in the best condition.

Each gang should be equipped with a large tool box on wheels, that can be easily moved from one engine to another. This box should contain all the tools necessary to handle their special line of duties. Jacks should be distributed around the house at several points so that it is not necessary to walk any great distance to get one. If each gang is given the tools for their work, it will be found that a large, expensive tool room is unnecessary. If there is a tool room, it should be under the care of the head machine hand in the machine shop, and he can maintain the tool repairs in his leisure moments.

As the winter is the most severe on equipment, all means possible should be taken to make the roundhouse as comfortable as possible so that the work can be given prompt and effective attention. Sometimes it is impossible to get good mechanics to work in the roundhouse on account of the steam and gas, and if this can be prevented it will benefit all workmen. The best system of lighting is the headlight system; that is, have a strong electric headlight placed at the front and back of every pit and the light will be given in such a way that there will be no reflection on the work.

The old idea that a man is a good workman just because he appears to be a hustler is wrong, for we find many men who work hard but do their work under such conditions as

are usually found in the poor roundhouse, who do not, as a rule, turn out very much or very good work; and if their shop conditions can be bettered, they are bound in turn to become better workmen. Overcoming failures and handling a great number of engines includes "hustle" to some extent, but on the other hand it requires the elimination of all unnecessary moves and wasted time, so that the best way to increase the efficiency of a terminal is to study every operation and find some way to better the conditions and reduce the handicaps.

## HEAT TREATMENT OF STEEL\*

BY GEORGE HUTTON

What is heat treatment? A method of changing the structure of any steel forging from its normal state after the forging operation to a more efficient article by increasing the tensile strength. The process is as follows: First, annealing all forgings to relieve strains set up by hammering and unequal heating during the process of forging; second, heating to a certain temperature and quenching in a cooling medium to attain density of structure and tensile strength; and, third, reheating to a lower temperature to attain elasticity and allowing to cool in a dry place or in the furnace. A correct knowledge of the carbon content of the steel, which is essential, the proper temperatures for the different operations together with a properly calibrated pyrometer, a cooling tank, running water of the right temperature, or a suitable quenching oil, and facilities for the quick handling or transferring of forgings from furnace to cooling tank, constitute the necessary requirements for the heat treatment of forgings generally used in locomotive work.

To describe technically the various changes the steel undergoes by heating and cooling is only confusing to the average shop man, and is not absolutely necessary to success in heat treating. In all well regulated railroad shops the foreman who has supervision over the heat treating receives instructions from the proper authorities regarding the temperatures for quenching and draw-back, the quenching medium to use and the physical test which the forgings are expected to stand after treatment; therefore, his principal duty in heat treatment is strictly to follow out these instructions. However, let it be borne in mind that there is something more essential than just heating and cooling steel. One should know the nature of the material he is working, also the results obtained after certain operations, viz.: if the forgings are improved; if the structure of treated steel when fractured shows evidence of overheating or underheating; if it has been hammered when too cold or too hot; if the test piece when pulled shows the right texture; if a test piece shows an ideal or undesirable fracture, etc. All of these are practical points with which the man who works in steel or iron should be familiar.

For heat treating, a muffle or semi-muffle furnace is required, preferably with a door at each end, and a perfectly flat bottom. If main and side rods or axles are to be treated a car-bottom furnace with a removable bottom mounted on wheels is required. The hot forgings are pulled out of the furnace on this truck, thus facilitating the handling of long forgings without bending. For forgings four feet long or less the removable bottom is not necessary as all short forgings can be readily removed from the furnace without distortion. When forgings are placed in the furnace care should be taken to stack them so that one will not come in contact with another and so that they will not sag when hot. The forgings should be charged when the furnace is cold to insure proper placing. If an oil furnace is used the combustion chamber should be large enough to distribute the flame evenly over the entire heating space above without coming directly in contact with the forgings. A pyrometer must be

\*Second prize article in the competition which closed May 1, 1916.

used to ascertain the temperatures and care should be taken to see that the forgings themselves are at the correct temperatures. For instance, the pyrometer may show 1,500 deg. F. while the forgings may not have reached that temperature. A radiation pyrometer is excellent for this work as it eliminates guess work in this respect, the temperature of the forgings only being indicated, regardless of the temperature of the furnace.

There should be provided a sufficiently large cooling tank, preferably round and sunk to within one foot of the floor level, filled with water which should be at a temperature of at least 80 deg. to 90 deg. F. when the forgings are quenched. The tank should be fitted with supply pipes and overflow so that the temperature can be maintained regardless of the number of pieces being treated. If a soluble quenching oil is used the tank should be equipped with a pump and storage reservoir so that the oil will circulate at the above temperature without waste. There should also be provided a crane or trolley working from the furnace to the cooling tank with quick hoisting and lowering facilities. The same furnace may be used for the draw-back heats only at a much lower temperature.

Take, for example, forgings made from open-hearth steel or open-hearth vanadium steel having a carbon content of .35 per cent to not over .50 per cent. If the forgings are to be treated before machining, which is the case with most locomotive forgings, excepting crank pins or other short, round work, they may be rough turned before heat treating. The forgings should first have been annealed at a temperature suitable to the carbon content, from 1,550 deg. F. to 1,650 deg. F., and allowed to cool. They are placed in the furnace and the temperature raised slowly to 1,500 or 1,550 deg. F., conforming always to the carbon, and held at that temperature from one-half hour to one hour, depending on the weight or thickness of the pieces. The temperature should steadily

down to govern the length of time required in the quenching bath, especially for irregular shaped forgings.

After the quenching operation the furnace is allowed to cool down about 200 deg. F., the forgings again being placed in it the same as before and the temperature raised from 1,250 deg. F. to 1,310 deg. F., depending on the requirements which they must meet. The furnace may be cooled off with forgings in it or they can be taken out and stacked in a dry place to cool.

By these operations the tensile strength of the forgings has been increased from 80,000 lb. per sq. in. to 120,000 lb. per sq. in., and can be increased still more, although too high a tensile strength is not always desirable. The relative hardness and toughness of steel forgings can be controlled by the temperature of the furnace according to the requirements of the article being treated.

## RIVET CUTTER FOR FREIGHT CAR REPAIRS

BY H. M. BROWN

Shop Superintendent, Chesapeake & Ohio, Huntington, W. Va.

In repairing steel freight cars it has been the practice at this point to use a sledge and cutter for the removal of rivets. The rivet cutting required on a car in the shop for general repairs ordinarily takes from four to six days, with a gang of four men. In order to reduce the time the cars are detained in the shop, the pneumatic hammer shown in the drawing has been developed for doing this work. By its use the time consumed in cutting rivets under the above conditions has been reduced to about 14 hours.

The machine is built up of two heads machined from old tire steel, and a barrel of Shelby steel tubing. A piston, 1 63/64 in. in diameter, works in the barrel and it has been

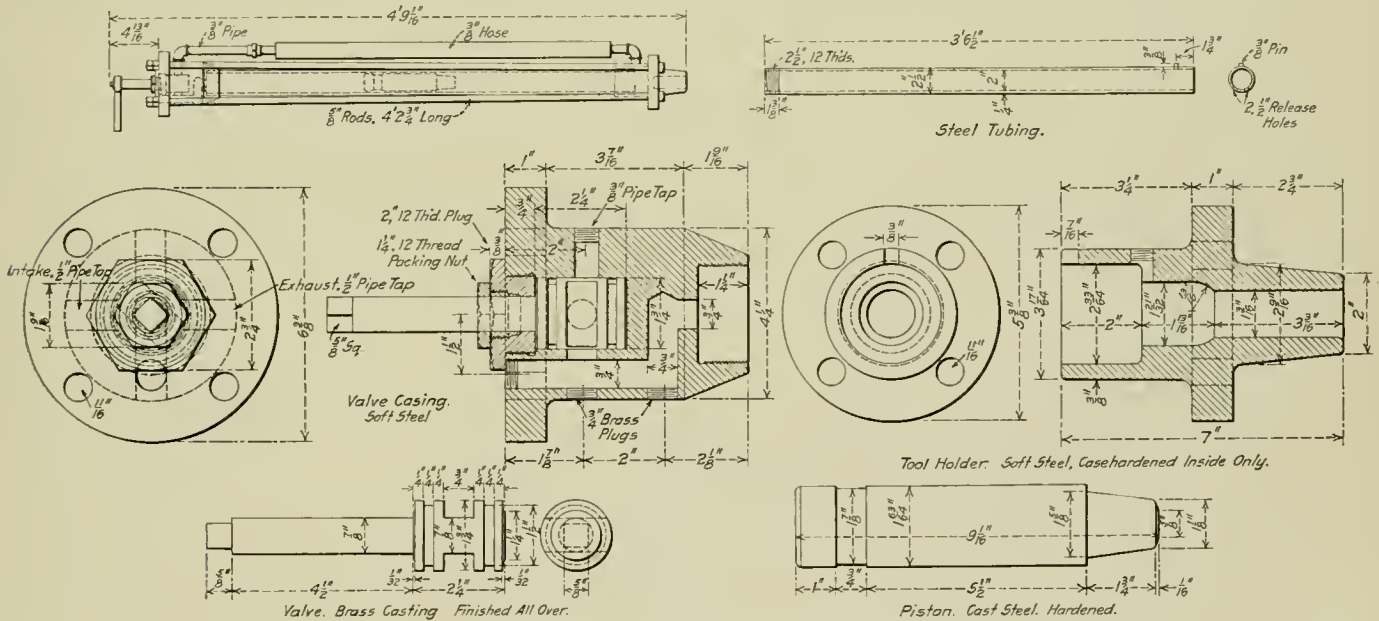

Rivet Buster Used in Repairing Steel Cars

rise to the desired point and never be allowed to drop back during the operation.

Each piece should be removed from the furnace and quenched as quickly as possible. In all cases of heat treatment, steel should be quenched at a rising temperature or one which has been maintained constant. The forging should not be kept submerged until it reaches the temperature of the cooling medium, but should be removed while it is still hot enough for oil or water to sizzle on it. This can easily be determined by practice and no rule can be laid

found unnecessary to finish the latter, as the tubing is received sufficiently smooth to answer the purpose satisfactorily. The heads and the barrel are held together by means of four 5/8-in. rods passing through the flanges of the heads.

The upper head is fitted with a valve working in a cylindrical chamber, by means of which connection can be made alternately between the inlet port and the upper end of the barrel, and between the inlet port and the lower end of the barrel, the same operation placing the end of the barrel not in communication with the inlet port directly in con-

nection with an exhaust port leading to the atmosphere. The hammer is operated by turning the valve about on its own axis, a handle being provided on the projecting end of the stem for this purpose. Two relief holes are drilled through the barrel  $7\frac{1}{2}$  in. back from the lower end.

When the rough service to which these hammers are subjected is considered, they have required very little maintenance since they have been in service. They have also resulted in a saving in cutters as well as in the elimination of the danger of personal injury, which always exists where the sledge and chisel are used.

### LOCOMOTIVE PIPING AND JACKETS

BY M. J. CAIRNS

From the manner in which some roads apply piping and jackets to locomotives, it is quite evident that but little consideration is being given to obtaining an arrangement which embodies ease of application and removal and neatness of appearance. This thought has very likely occurred to quite a few roundhouse foremen when a staybolt needed replace-

row from the outer edge of the running board, as shown in the arrangement drawing, Fig 1, and in Fig. 2. If it is not deemed advisable to use this arrangement on account of the obstruction offered by the air cooler pipes or an exceptionally large reservoir, the pipes may be laid flush with the running board as shown in Fig. 3. The pipes under the cab should be arranged as shown in Fig. 3, which is an improvement over the present method of running them in a row over the side sheets, which will require their removal when work is to be done in that section. Unions should be applied just ahead of the throat sheet and above the cab floor on those pipes which extend upward, thus supplying a long felt want where stripping is necessary when working on staybolts.

In the cab the gage pipes running from the automatic brake valve and main reservoir pipe, the bell ringer and sander pipes, also the excess pressure pipe leading to the pump governor, can follow the corner band. The blower, the steam heat line, the gage cock and the water glass drains can do likewise at least over the bottom jacket section. This will clear the backhead, reducing the amount of stripping

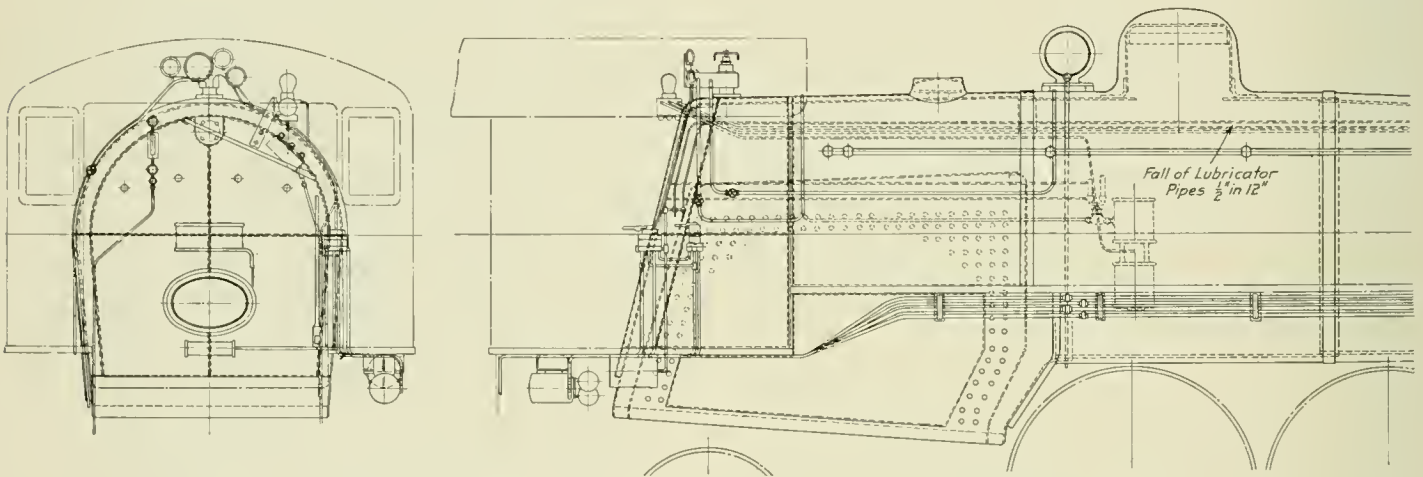
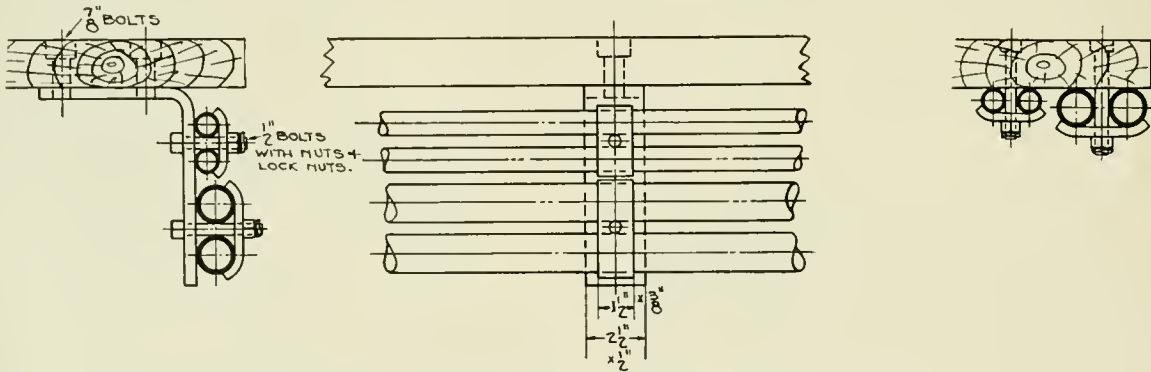

Fig. 1—General Arrangement of Locomotive Piping Which Will Expedite Removal and Repairs

ment. Rather than remove a section of the jacket covered with numerous pipes running apparently in the line of least resistance, they proceed to punch a hole through the jacket and lagging, for which they cannot be greatly censured. The description, dealing with the arrangement for a Pacific type

to be done to a minimum when replacing broken staybolts or cleaning tell-tale holes. The various lubricator pipes with the sander, bell ringer, and excess pressure pipes may enter under the jacket at the corner band as shown in Fig. 1, continuing forward to their respective positions with a fall



Figs. 2 and 3—Arrangement of Piping Under the Running Board

locomotive, is offered in an effort to bring more thought to bear upon this subject.

#### PIPING

The various pipes running ahead under the running board, such as the blower, steam heat, signal and train line, main reservoir and brake cylinder pipes, may be suspended in a

of about  $\frac{1}{2}$  in. to the foot. These pipes had best emerge from the jacket at a seam rather than through a hole punched in the center of the jacket.

The turbine drain can enter under the jacket at the seam shown in Fig. 6, continuing under the jacket to the bottom center line of the boiler, where it can emerge for a short distance. This arrangement will give good protection against

freezing. The injector steam pipes should clear the jacket as much as consistent, taking care, however, that they are so braced that vibration will be eliminated. With non-lifting injectors, the delivery line can usually be arranged to clear the staybolt area by placing it on a line parallel with the front of the mud ring. The back corner of the mud ring may be cleared considerably by moving the distributing valve and equalizing reservoir back closer to the cab plate. Considerable time can be saved by properly placing unions, and the number of joints can be greatly reduced by the use of angle and globe valves with union outlets and elbows and tees with unions. Pet cocks should be applied at the lowest point in the pipe line, for proper drainage.

All pipes should be securely clamped, using nuts and lock nuts, eliminating vibration with its subsequent leakage and chafing. The use of graphite and oil is recommended for making the pipe joints. Copper pipes give the best results under the jacket, experiments with wrought iron pipes show-

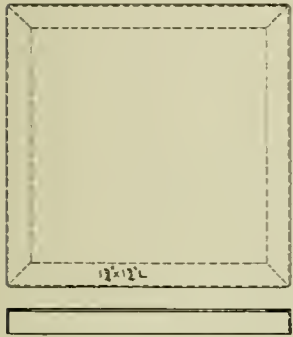

Fig. 4—Angle Iron Type of Construction for Holding the Lagging Over the Staybolt Area

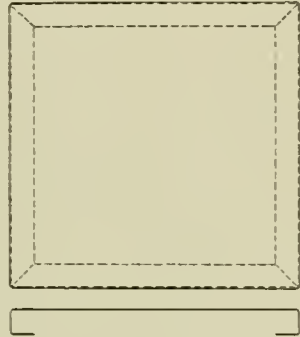

Fig. 5—Suggested Arrangement for Holding Scraps of Block Lagging; This May Be Removed in a Unit

ing that frequent renewals are necessary when they are so placed. Double strength pipes should, of course, be used for steam and air, thereby overcoming the breaking of threads experienced with single strength pipes due to vibration. Chafed pipes are being reclaimed to quite an extent by welding.

As an experiment, a large trunk line recently piped an engine using the foregoing arrangement at a cost of \$170.

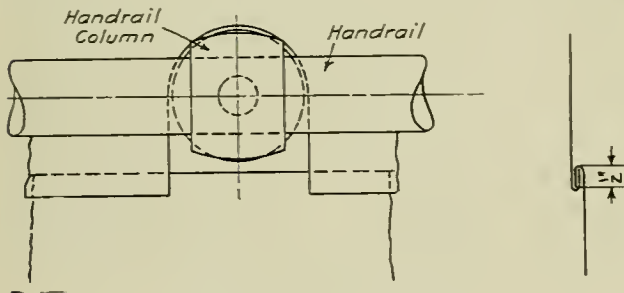

Fig. 6—Longitudinal Jacket Seam

including labor and material, in which some few small pipes were used from the material removed. The cost of replacing the old pipes just as they were removed was estimated at \$70, making an additional cost for the engine of \$100. This extra charge would soon be recovered if staybolt breakages were numerous, but the application of this arrangement to old power passing through the shop would, of course, require some consideration before the present arrangements were changed. However, for new engines or engines requiring many new pipes this plan can easily be followed.

JACKET AND LAGGING

The sectional type of jacket should by all means be used over the firebox, the number of sections being such as to

facilitate staybolt replacement. The usual form of construction is the angle iron type shown in Fig. 4, which is applied over block lagging in the common staybolt area and over bulk lagging plastered around flexible staybolts. Fig. 5 is a suggestion for a jacket section in which bulk lagging made from scraps of block lagging may be applied, the lagging being held in place by means of chicken wire or thin metal strips acting as a binder. This could be placed over common staybolts and the whole section removed as a unit, saving the time now used in re-applying the jacket and lagging separately. Fig. 6 shows a longitudinal seam suitable for use on the barrel of a boiler. This allows the removal of the jacket without disturbing the handrail columns, which is especially desirable when applying barrel patches. The use of rivets is done away with, the sheets being lapped 1/2 in. and hammered together. The top sheet laps over the bottom sheet, thereby shedding water.

THE IMPORTANCE OF THE ROUNDHOUSE FOREMAN

BY G. C. CHRISTY

General Foreman, Illinois Central, McComb, Miss.

There cannot be too much said for the roundhouse foreman; a "live one" is the busiest man in the mechanical department. He has to be thoroughly posted on the engine-men's and firemen's contracts, has to be in position to answer any question right off the reel, and even talk with the men's wives on some occasions, trying to explain to them that they cannot get a pass for themselves within the next few minutes. He also has to be very much of a diplomat, to explain to the different enginemen why such work that was reported wasn't done, and why work was done that wasn't reported.

He has to be a good judge of human nature, that he may select the class of men that will make good and be an advantage to his organization; because if he hasn't a first-class organization, he cannot get results. "Results" in the roundhouse means more than one might think, without going a little further than the outbound track of the roundhouse. It means to have all engines thoroughly inspected for all defects, and then see that all defects are corrected in the proper manner within a limited amount of time, that the engine may be kept in road service instead of standing over the drop pit. Any foreman can discharge an employee, but it takes a good foreman to get results from one.

So it is with keeping engines in the service and also in good condition. Any foreman could run a roundhouse if he was permitted to shop the engines whenever he thought they were getting in bad condition; but it takes a man who will look ahead, to keep his power in good condition and at the same time keep it in service. If he has his engines thoroughly inspected, then sees that the work is done, he will be in such condition that none of the Government inspectors can come around about the time the engine is ready to leave the station, and order it out of service. Above all, this will reduce engine failures to the minimum, which are the worst trouble the master mechanic has to answer for.

The subject of engine failures attracts everybody's attention on the railroad from the general manager to the box packer who failed to pack the box that caused the failure. Even the commercial agent, who may be a thousand miles from the roundhouse foreman, is out doing his best, soliciting what the railroad depends upon—revenue. He gets the business and advertises the train to maintain such schedule that will deliver his customer's goods at a certain destination at some specified time. The train may maintain the schedule over several divisions until it arrives on some division with a weak organization in the roundhouse; the engine will get out late, causing terminal overtime, which is money, then get out on the road, fail for steam on account of tubes being

stopped up, or run hot, due to the application of new bearings and no lubricant, or some other cause. This will not only delay the train, but delay everything on the railroad.

The customer will go to the commercial agent and notify him that he doesn't want any more of his railroad's service. Then every officer, from the general manager on down the line, general superintendent, superintendent and master mechanic, will have to know the cause of the failure. A big file of correspondence will eventually arrive at the roundhouse foreman's office, for him to tell the entire railroad why they cannot run trains on schedule time. After the foreman has studied awhile, he will try to answer this correspondence in such manner as not to reflect on his organization, or his ability to handle a roundhouse. The best way to answer such delays is not to have them; by having good organization, which

## THE CAMERA IN A RAILROAD SHOP

BY C. L. DICKERT

Assistant Master Mechanic, Central of Georgia, Macon, Ga.

It is often necessary to make sketches and blue prints showing defective material, weak parts, broken parts, and a great many other things around a shop. It is very difficult in a good many cases to show up on a drawing the exact conditions and in some cases a lot of time is consumed in making drawings. We have overcome a lot of these troubles by the use of a camera. A photograph is taken of broken and defective parts, which shows up in detail the exact conditions in such a way that it cannot be disputed.

The camera is not expensive and does not require any skill to handle it. We do our own developing and printing.

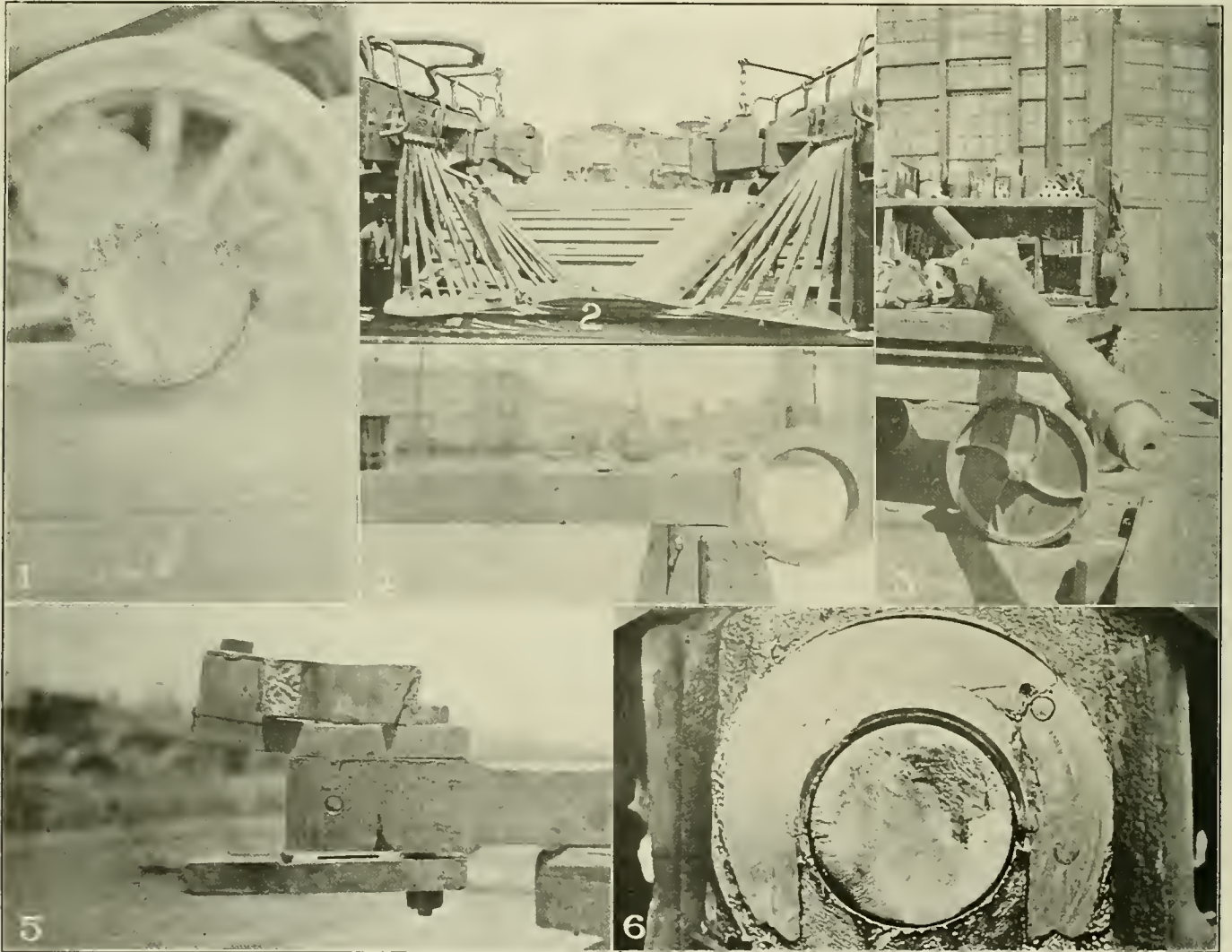

Some Examples of the Use of the Camera in the Central of Georgia Shops at Macon

requires co-operation. To get this, the foreman must be absolutely fair and square with all his men and those with whom he comes in contact.

**COMPOSITION OF COAL ASH.**—Coal ash contains silica, alumina, iron pyrites and other mineral matter, depending upon the chemical composition and physical condition. These cause the ash to fuse more or less easily. The temperature at which firebrick will melt is sometimes influenced by the composition of the ash. For instance, a certain ash might melt at 2,600 deg. F. and a certain firebrick at 2,800 deg. F., but together in a furnace both might melt at 2,500 deg. F.—*Power.*

The accompanying photographs show some of the work done with the camera. Nos. 1 and 6 show broken driving axles; No. 2 shows a comparison between two locomotive pilots, one made with round iron ribs, the other with ribs made from scrap tubes; No. 3 shows a broken piston; No. 4 a cracked side rod, and No. 5 a broken front end main rod strap. Each film is numbered and dated, a book record is kept and the negatives filed for future reference.

**STEAM TURBINES.**—Highly economical steam turbines must necessarily be operated condensing, but there are many cases where high steam economy is not most important, and the non-condensing turbine often finds favor.—*Power.*



## ELECTRIC FURNACES FOR TEMPERING TOOLS

The output and efficiency of any shop, whether railroad or industrial, is dependent on the capabilities of the workmen and the service obtained from the tools they use. The first is a matter of the experience of the workman and may or may not be in the hands of his employer to regulate. In the second case, however, it is not impossible nor difficult to provide proper tools with which the work is to be done. The tools must be properly formed and heat-treated. Tests have shown that a variation of 50 deg. in the heat-treatment of high speed steel makes a difference of from 30 to 70 per cent in the life of a tool according to its size.

This degree of refinement can be best obtained in electric furnaces provided with suitable pyrometers for the accurate determination of temperatures. Where these furnaces have been used they have been found especially successful. The equipment shown in the accompanying illustration is in use in the Burnside shops of the Illinois Central, where all taps,

The acknowledged advantages of this equipment by the road on which it is used are, the accurate control of temperatures, the number of tools that may be treated at one time, the less liability of imperfect tools due to oxidization, and the ease of operation with increased capacity. In regard to the latter item, it is said that with the installation referred to above, two tool dressers and their helpers have been eliminated. It must not be assumed, however, that with all the refinements in the construction of the furnaces and the accuracy in the control of the temperatures, the work of treating the tools can be done by inexperienced men. It is practically impossible to lay down a hard and fast rule for the heat-treating of the various grades of steel. The size of the tool and the work for which it is intended will determine its treatment, all of which requires the service of an experienced man. With the electric furnace he is able to get more uniformly perfect results and can handle a much greater amount of work with less labor.

Experience on the Illinois Central has shown that the best results with taps, dies and other tools made from 1.10 per

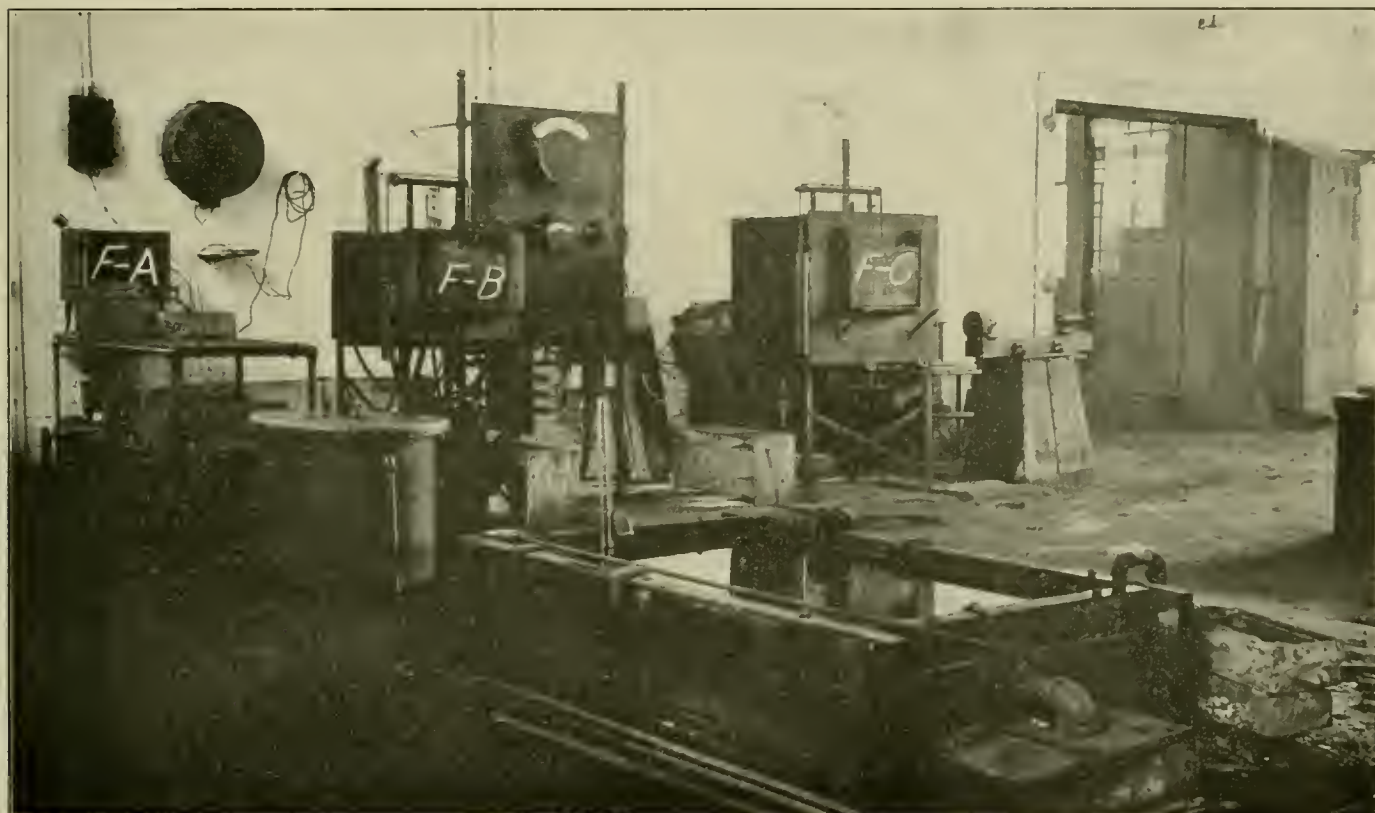

Installation of Electric Furnaces at the Burnside Shops of the Illinois Central

dies, reamers, shear blades and, in fact, all tools except lathe and planer tools, are treated by the electric furnace.

The equipment consists of types F-C, F-B and F-A electric furnaces made by the Hoskins Manufacturing Company, Detroit, Mich. The type F-C furnace is of the carbon resisting type with which temperatures between 1,000 deg. and 2,500 deg. F. can be obtained. It is used almost exclusively for treating high speed steel. The type F-B furnace is provided with heating units made of a special alloy of nickel-chromium wire of large cross section. This furnace is used where temperatures up to 1,800 deg. F. are desired, and is employed in treating tools of carbon steel. The type F-A furnace is used for tempering the carbon steel tools and, although temperatures of 1,800 deg. F. can be obtained in it, it is seldom heated to above 800 deg. F. for the service in which it is used.

The heating element which is employed in this furnace is made of Chromel wire wound on an alundum core.

cent carbon steel are obtained by heating them to between 1,350 and 1,600 deg., according to their size. The 0.9 per cent carbon steel which is used for mandrels, beading tools, etc., is heated to between 1,400 and 1,625 deg. W. C. Scofield, the foreman blacksmith who has charge of the work done in these furnaces, states that in hardening the tools he finds it more satisfactory to dip them on a declining temperature. That is, he heats them slightly above the desired temperature, then allows them to cool back again before dipping them. In dipping the spiral reamers they are rotated slowly in a direction opposite to that of the spiral. This, it is claimed, will prevent warping. The long taps and reamers are packed in charcoal in an iron tube, brought up to a red heat in an oil furnace and soaked at the proper temperature in the electric furnace.

It takes from 1 to 1½ hours to bring the furnaces up to working temperature, which might be considered a disadvan-

tage were it not for the fact that the gradually rising heat can be utilized in drawing the temper on some of the tools that were hardened the previous day, as is done on the road whose installation is described above. The temperatures at which the type F-B furnace is used range between 1,350 and 1,625 deg. F., according to the size of the tool being treated and the grade of the steel. Not being used to its full capacity the heating elements are not overtaxed and it has been found necessary to renew them only about once a year. This furnace is also used to preheat the high speed steel tools before they are placed in the high temperature of the type F-C furnace, this practice having been found necessary. In handling this grade of steel it is also necessary not to permit soaking heats; that is, as soon as the steel has been brought up to the required temperature it should be removed from the furnace. It is also necessary to allow a certain amount of air to enter the furnace while treating the steel, as it has been found that a reducing atmosphere will produce soft spots on the tools.

The type F-C furnace, which uses the carbon plates as heating elements, is used to more nearly its heat capacity, and it has been found that the carbon resistor and the carbon plates have a life of about 150 hours, while the bottom plates and electrodes have a life of about 500 hours. If the furnaces are allowed to overheat, the maintenance, of course, will be greater and the linings of the furnace will deteriorate. It is necessary that the pyrometer be accurately maintained and it should be checked once every two weeks, either by a standard pyrometer or by the use of melting metal cones having a known melting point. Alternating current at 440 volts and 60 cycles is used in the type F-B and F-C furnaces, while 220 volt direct current is used in the type F-A furnace.

## GETTING RESULTS IN AN ENGINEHOUSE\*

BY THOMAS F. RYAN

Roundhouse Foreman, Atchison, Topeka & Santa Fe, La Junta, Col.

It is almost impossible to lay down a plan of organization that will apply to all enginehouses alike. So many different conditions apply that each case must in the end be studied separately. The class of power, the class of service, the general characteristics of the employees, the size of the terminal and whether it is at a main shop or at an outlying point, all enter into the question.

However, the fundamental principle underlying all successful management is thorough organization. In this age a man not gifted with talent for organization in greater or less degree has no business at the head of any plant or department.

In all matters pertaining to shopmen and methods the roundhouse foreman should report to the general foreman, and in things relative to enginemen the roundhouse foreman should report to the master mechanic or to his office, as the general foreman of a busy shop has no time to devote to enginemen.

I would divide the work into several sections: Inspection, repairing and keeping accurate record of the work done. On arrival at the roundhouse tracks every engine should receive a thorough inspection. This means to test out the air equipment, test the boiler appliances, note the steam leaks, try the shoes and wedges and make needed adjustments, key the rods and test the engine for blows in the valves and cylinders, and report the defects found. The engine should then pass to the coaling station, sandhouse and cinder pit, and these should be all on one track. This track should lead direct to the turntable and should also be equipped with a water crane; 20 min. wasted on each engine going from one track to another at the end of a 50-engine day means 1,000 min. total delay.

Having reached the roundhouse we are now ready to

begin repair work, and this need not be discussed farther than to say that the inspection should be made by competent practical men and the work they find should be done, as well as all necessary work reported by the enginemen. It should be done *right* and it should be done *now*. In the event that time and circumstances will not permit of certain repairs being made on the date of inspection, the report should be held and arrangements made to complete the work on the following trip. The old adage of saving the pennies and letting the dollars look out for themselves is no truer than that to do the little jobs on an engine will prevent the big ones.

With proper traffic conditions prevailing and with proper handling of power by train dispatchers to keep engines arriving singly rather than in groups, repairs should be complete and the engine ready for service within eight hours on an average. As repairs are completed the outgoing inspection should begin and every item should be looked over and each appliance tested out to prove that it is in working order. This may sound like a large contract, but in practically every roundhouse there are a sufficient number of men to perform these duties, and here is where the ability of the roundhouse foreman as an organizer is shown most plainly.

I do not feel that it is appropriate to dwell on the matter of improving shop methods and tools and eliminating the lost motion in making repairs and in educating men to be efficient. Pages could be written on this subject, but I wish only to mention one device that is not used in all enginehouses. This is a portable tool box, mounted on an ordinary warehouse truck and containing sufficient wrenches, sledges and other tools to keep men from going a long way to the tool room every little while with all the incident temptations to visit a little. This will also eliminate tool cupboards from the roundhouse. When a mechanic is done with one engine he wheels his box over to the next.

In the office every item should be carefully attended to and record kept of the man doing the work. The easiest way to do this is to typewrite the reports for each engine and put them up on a wall board *at the engine* where they will be convenient for the gang foremen, mechanics and hostlers to check while the engine is in the house. When the work is done and the reports bear the signature of each man who did the work on the engine opposite the line on the report covering that operation, the report should be taken to the roundhouse office and filed. Every report on any given engine is thus available at any time. This also serves to locate responsibility for poor work, and further serves to convince enginemen that they are sometimes in error when they say a part that failed has been reported by them several times.

To get results from an enginehouse requires the co-operation of the transportation department. Trainmasters are anxious to keep their engine assignment down, and one of the surest ways of accomplishing this is to arrange for the long lay-over of the engines at the home terminal, and give the roundhouse men a chance to make repairs when they should be made and without overtime. I know the trainmaster does not figure the mechanical payroll, but the money all comes from a common treasury in the end. Yardmasters can help by advising roundhouse foremen in the morning what power they want for 24 or even 12 hours, and when they want it. It is easy for a roundhouse foreman to ascertain what traffic is coming, but what he would like to know is when it is going, and how much there is of it. Many an engine lies at a terminal amply long to do all necessary work if a number of engines had not arrived in a bunch at five o'clock in the evening, or if the roundhouse foreman knew they were going to be on hand 15 hours, before 8 hours of the 15 were gone.

\*Entered in the Engine Terminal Competition.



weight is allowed to rest on the tee head to grind the joint.

The arrangement for grinding the dry pipe into the tube sheet is shown in detail in Fig. 2. It works in a very satisfactory manner if care is taken to adjust the rollers to the

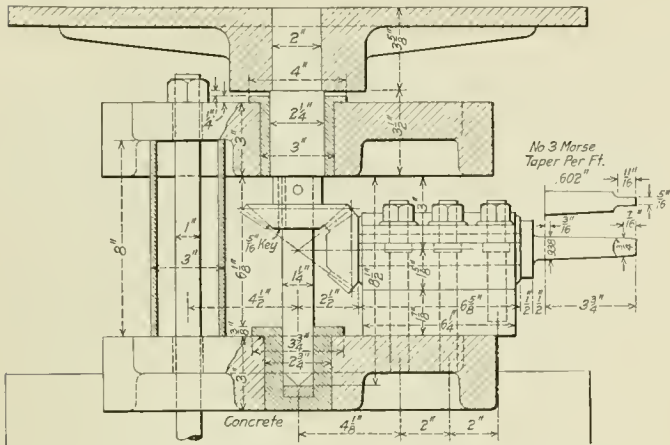

Machine for Grinding the Dry Pipe in the Tee Head

proper height at the back end of the pipe, and the job can be completed in the time it takes to grind it in by hand. The machine is very easily set up and can be handled by two men.

### SOME POINTS IN ENGINEHOUSE MANAGEMENT\*

BY C. E. KELLY

The first consideration in enginehouse management is the highest degree of efficiency at a minimum cost, and in order that this may be obtained there must be a man at the head of this work who is broadminded, fair and firm, and one who is farseeing.

Tracks for engines waiting ready to go out should be open at both ends so that engines can be placed on them or taken out without having to move other engines.

Stand pipes for taking water should be so located that water can be taken from several different tracks.

A roundhouse should be well heated in the winter. Much time is lost day after day by men standing by a stove to get warm.

In the handling of roundhouse forces I find that the method of making special jobs of the work gives good results; in some cases where there is enough work of any one class to assign a particular man to that job, he will sooner or later learn to equip himself with the material and tools that he will need for his class of work, and by continued practice he becomes very expert. However, this does not apply to all classes of work, for to specialize all the work does not meet with the approval of all the workmen. Many of them are better satisfied to work on different classes of work, as a change of work from time to time keeps it from becoming monotonous. For running repair work it is advisable to make a specialty of the valve work, the cab work and the air-brake work, and where heavy class repairs are made in the roundhouse special men may be assigned to this; also to the work of inspection. Where the inspector has no authority in regard to having the work done, but simply reports it and leaves it to the workman's judgment, he has to take someone's word for the actual performance of the work. The inspector should be held responsible for the manner in which the work is done.

What methods may be applied to the enginehouse organizations in general to prevent engine failures? From a me-

chanical point of view there is no method by which all engine failures can be prevented. However, the number of engine failures may be greatly reduced in various ways. For instance, hot journals on tanks, trailers and engine trucks having a babbitt metal bearing in the crown of the brass, if examined at regular intervals by removing the brass so that all of it may be seen, will prevent many engine failures from hot journals due to the metal wearing out of the brass next to the hub, where it would not be detected in ordinary oiling or packing. Keep a record and have the brasses removed at least once every two weeks, and these hot box failures will decrease.

Make every man respect the necessity of doing the work in a correct and workman-like manner. The great secret of success in handling a roundhouse, large or small, lies in perfecting a system that will automatically assist in carrying on the business.

### RATCHET GREASE CUP

A locomotive side rod grease cup has been developed and the patent applied for by C. E. Stocker, Mill Valley, Cal. The purpose of this special design of cup is to keep the grease plug from working loose while in service without the use of the troublesome jam nut. This is done by means of a ratchet. The pawl of the ratchet is mounted in a spring ring on the outside of the cup. The point of the pawl passes through the side of the cup and bears directly on the root of the thread of the grease plug. This plug has four V-notches

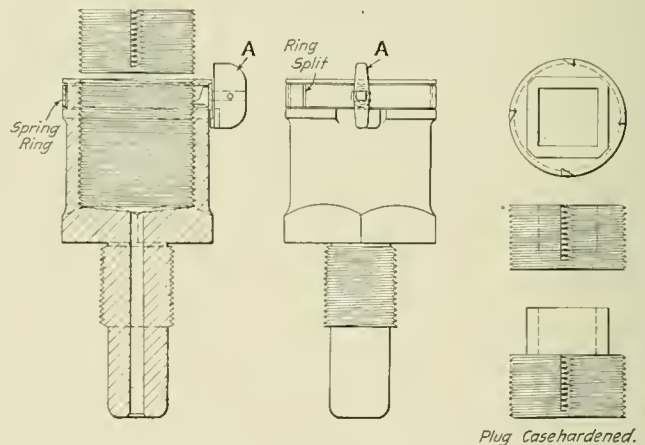

Ratchet Grease Cup for Locomotive Side Rods

made in the thread and slightly deeper than the root of the thread, as shown in the drawing. The point of the pawl engaging in these notches prevents the plug from working loose but does not hinder the screwing in of the plug. When it is desired to remove the plug the pawl is lifted from the V-notch by slightly turning the button A which rides on the wedge-shaped lug on the body of the grease cup. This cup has been tried on one of the large western roads and has proved successful.

CRANES, HOISTS AND TROLLEYS.—The general provision of traveling cranes, jib cranes, hoists and trolleys in modern shops has made a great change in the manner of handling work and the attitude of mechanics to big jobs. When a casting weighing many tons had to be machined in the old-time shop it was a herculean job to transport it from one machine to another and fix it in position. So general has the power traveling crane become in the past few years that it is a commonplace sight to see machine parts weighing many tons being transported through shops and placed on machines with no fuss and requiring the help of only one or two men besides the crane operator.—A. S. M. E. Journal.

\*Entered in the Engine Terminal Competition.

# New Devices

## FUSIBLE CROWN SHEET PLUG

The proper maintenance of the fusible plug where it is applied directly to the crown sheet is generally a difficult matter. The necessity for frequent removal of the plug for inspection and to prevent the accumulation of scale is hard on the threads in the crown sheet and the projection of the plug inside the firebox is burned away by the direct action of the fire.

In order to overcome these difficulties, the type of plug shown in the illustration has been designed and patented by Robert Bonnett, shop foreman of the Hammond Lumber Company, Eureka, Cal., and is in use both on the locomotives and stationary boilers of that company. This fusible plug consists of a brass plug containing the usual fusible metal core, and a steel bushing, the latter being applied to the crown sheet. This bushing when once applied becomes a

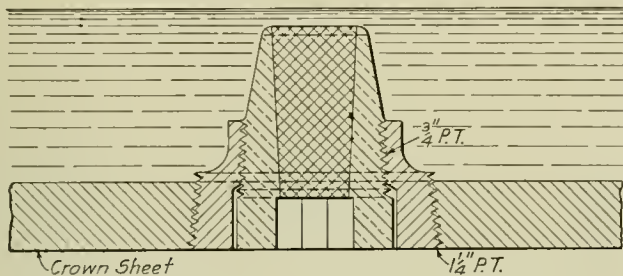

Fusible Plug Flush with the Inside of the Crown Sheet

part of the boiler, and remains permanently in the sheet. The brass plug is screwed into the upper end of the steel bushing, which projects into the water space above the crown sheet where the temperature is considerably lower than that of the crown sheet itself. The graphite lubricant applied to the threads of the plug is thus prevented from hardening, and the plug may readily be removed at any time, without injury to the threads. When in place the face of the bushing, the end of the plug and the crown sheet are all flush. A slot is provided in the end of the plug for the application of a thick screw driver, which is used to remove and apply it.

**WELDING PIPES.**—Welded pipes are made by the lap- or butt-weld process, differing, as the terms indicate, in the form of the joint, or weld, extending the length of the pipe. Since a comparatively larger welding surface is obtained by the lap-weld process, it is usually found to be stronger than the butt-weld and as strong at the weld as at any other place. Butt-welding is performed in a manner similar to lap-welding except that the edges of the "skelp" are slightly beveled off at the inside edge, the outside being a little wider than the inside, so that the edges will come squarely together when formed. The weld is usually accomplished by pressing the two edges together while at a welding heat, producing a reduction in the size; or, in other words, the original tube is made oversize and compressed by rolls and rings to the correct diameter and finish. Butt-welding is the practice in making pipe up to about 3 ins. diameter and lap-welding for all larger sizes.—*Power.*

## DUPLEX KEYSEAT MILLING AND COTTERING MACHINE

The duplex keyseat milling and cottering machine shown in the engraving has recently been designed by the Newton Machine Tool Works, Incorporated, Philadelphia. This machine increases production and eliminates much of the time ordinarily lost in laying out the work in cases where two keyseats are cut in opposite sides of the same shaft.

The spindles have double taper bearings, are 2 11/16 in. in diameter at the large end of the taper and 1 5/16 in. through the driving section. The spindle heads have automatic feed with safety release for cottering; the maximum feed per stroke of the table is 1/16 in. The spindles have four changes of geared speeds without requiring the removal of the gears, in addition to the back gears on each head, giving a speed range of 300 and 1,465 r.p.m. with eight changes. The single step driving pulley is 10 in. diameter, 2 1/4 in. face and runs at 735 r.p.m. Drums 12 in. in diameter and 8 in. face are mounted on the driving pulley shaft inside the base, connecting by belt to the spindles on which the back gears are located.

The work table or cross carriage is 44 in. long over all and 38 1/2 in. over finished surface, and is 9 in. wide. It

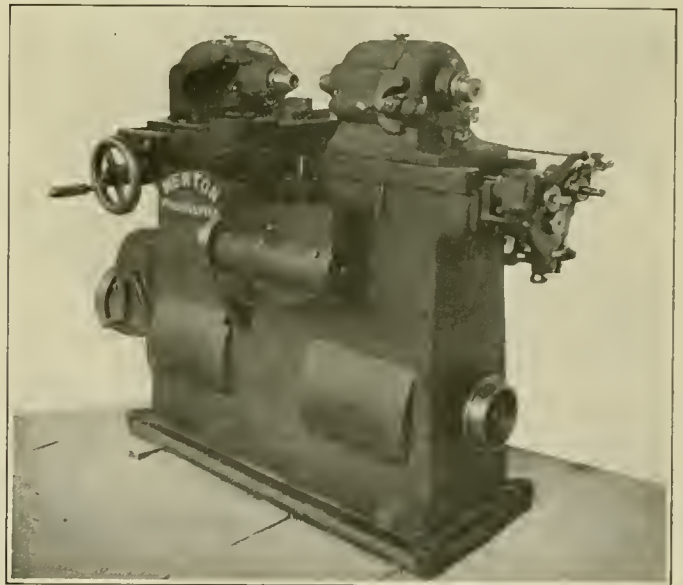

Duplex Keyseat Milling Machine

has three changes of feed, either continuous for long splines or automatic reversing for cottering. The maximum diameter of the shaft which can be operated on is 4 in. and the speeds and feeds are suitable for keyseats from 1/8 in. to 3/4 in. wide, inclusive. The maximum cross feed of the carriage is 24 in. and the height from the table to the center of the spindles is 3 1/2 in. The net weight of the machine is 3,000 lb.

For use in connection with this machine there has been

developed a fixture for this company's slotting machine for cutting both internal keys at one time, thereby assuring an accurate fit of the keys on all sides.

### COMPRESSED AIR METER

The illustration shows the Tool-om-eter, which is the one-inch size of compressed air meters, made by the New Jersey Meter Company, Plainfield, N. J. It has a capacity of 10 to 100 cu. ft. of free air per minute and is intended for the measurement of air used by shop pneumatic tools.

The moving element consists of a weighted piston in the upper or metering cylinder, a small piston in the oil dashpot cylinder and a rod joining the two pistons and extending upward where it moves freely, without contact, inside the sight glass at the top of the meter. This rod rises and falls with the pistons so that its height in the sight glass corresponds exactly to the position of the piston in the metering cylinder. The scale plate mounted against the outside of the sight glass permits reading the exact height of the top end of the rod.

Air enters at the lower left hand opening into the chamber surrounding the dashpot cylinder and passes through ported openings into the interior of the metering cylinder, the wall of which is drilled with a large number of small accurately-reamed holes uniformly spaced (only the holes in the plane of section are shown in the engraving.) To pass to the outlet chamber the air lifts the piston and exposes some of the holes to the flow.

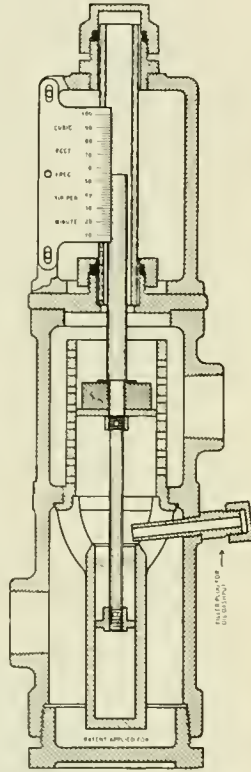

Compressed Air Meter

A small "head," or difference of pressure, is established between the interior of the cylinder and the outlet chamber, this pressure difference, only a few ounces per square inch, being fixed by the exact weight of the moving element and the area of the piston on which the difference of pressure acts. The moving element rises until the weight is exactly supported by the difference in pressure; the pistons and rod are then floating in static balance in a position corresponding to the volume of air flowing, the number of holes exposed and the height of the top of the rod in the sight glass. The divisions of the scale plate are calibrated by comparison with a standardized instrument to read correctly. This is not a velocity meter which would give readings proportional to the square of the volume flowing, but is a direct volume gage with a uniform scale on which one cubic foot is represented by the same distance whether working at low or high capacity.

**RAIL EXPORTS.**—The exports of rails from the United States last year were 391,491 tons, as compared with 174,680 tons in 1914, and 460,553 tons in 1913. The largest shipments last year were to Asia and Oceania. There was a very appreciable falling off in the exports to Canada, Mexico, Japan, and South America. On the other hand, the imports of rails into the United States last year were 78,525 tons, as compared with 22,571 tons in 1914, and 10,408 tons in 1913. The value of last year's imports was \$2,088,532, thus giving an average of \$26.59 per ton.—*Engineering*.

### ELECTRIC CEILING FAN FOR PASSENGER CARS

An indirect acting ceiling fan for use in passenger equipment has been developed by H. C. Hood and is being placed on the market by the Central Electric Company, Chicago.

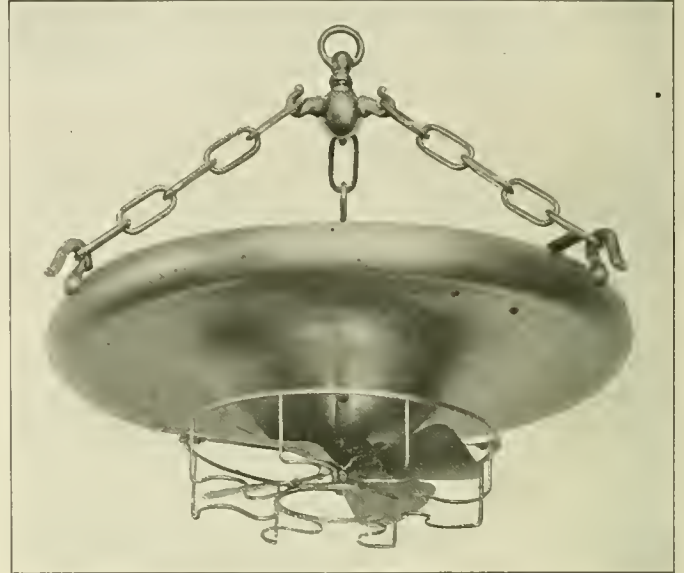

Indirect Acting Ceiling Fan

In its action it bears a relation to the usual type of ceiling fan similar to that which the indirect lighting fixture bears to the reflector type of fixture. Instead of allowing the draft



Application of the Indirect Fan to a Parlor Car; the Fans Are Placed Two Fixtures Apart

to come direct from the fan to the passengers, the fan blades are reversed, causing the current of air to be directed upwards against the curved surface of a large disk which serves

as a deflector, redirecting the air downward again on all sides of the fan; this air movement, however, is so gentle as not to cause any direct draft downward so that it strikes on the heads of the passengers.

There is a constant movement of air upward immediately below the fan and for an angle of about 45 degrees to the sides. Upon leaving the deflecting surface of the curved disk above the fan blades, the motion of the air is almost horizontal in all directions. This latter movement striking the quarter deck of the cars or the sides of a room, is again deflected downward. The result of this is that there is a gentle air motion which gives a decided effect of coolness in the car or room without a draft, a comparatively large volume of air being affected.

The fan construction is very simple, the blades being simply reversed from the ordinary practice in fan construction so as to draw the air toward the motor instead of away from it; the motor, however, is concealed behind the curved portion of the deflecting disk as shown in the illustration. The curve of this large disk is so designed as to deflect the air at the proper angle and at the same time provide for handling this air with a minimum of resistance, insuring maximum operating efficiency.

The car interior shows how this type of fan may be placed between the lighting fixtures without causing any undue congestion.

### THE "GUN" TAP

The "Gun" tap is the name by which this tap has been known during the time that it has been in process of experimentation. It takes its name from the fact that it was originally designed for use in gun work. On account of the tough and wiry material used in this class of work, ordinary taps were very apt to break. The name, however, should not be confusing as this tap is designed for use in all kinds of material and in all classes of shop work, railroad as well as industrial.

Reference to the photograph will show the different construction from the ordinary tap. The cutting edges at the point are ground at an angle to the axis of the tap in order to cut with a shearing action. This throws the chips, un-

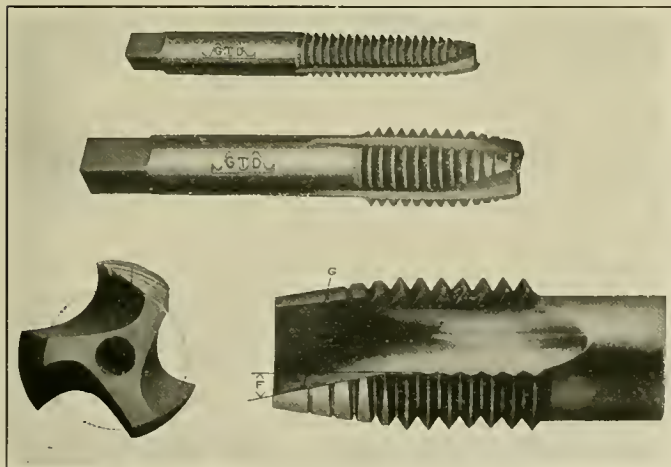

Types and Construction of the "Gun" Tap

broken, ahead of the tap instead of allowing them to collect in and clog the flutes. The two or three flute construction is thus possible, and much shallower flutes can be used than are possible in the ordinary tap. It is claimed by the makers, the Greenfield Tap and Die Corporation, Greenfield, Mass., that the tap has almost the strength of solid stock. If the tap should break it will only chip off the sharp cut-

ting edge, which can be easily reground and again placed in a satisfactory condition.

This tap does all its cutting on the first few teeth. The rest of the thread on the tap acts as a lead screw, steadying the tap and producing a very accurate thread. It is ground on the angular cutting edge instead of in the flutes as in the ordinary tap, and can be reground repeatedly until there are only three or four full threads left, and will maintain its size to this limit. A simple tap of this type can be used in many places where two and three taps, used successively, have been required, as the free cutting qualities permit working under much more difficult conditions and in much tougher materials than is possible with the ordinary type of tap.

### ARRANGEMENT OF THROTTLE AND STANDPIPE

The Baldwin Locomotive Works has recently developed a method of throttle and standpipe application which is shown in the engraving. The standpipe is flattened so as to make the section more oval than circular and the throttle valve can thus be placed closer to the dome. This leaves sufficient space, without enlarging the hole in the boiler, to permit the passing of a man's body without requiring the removal of either

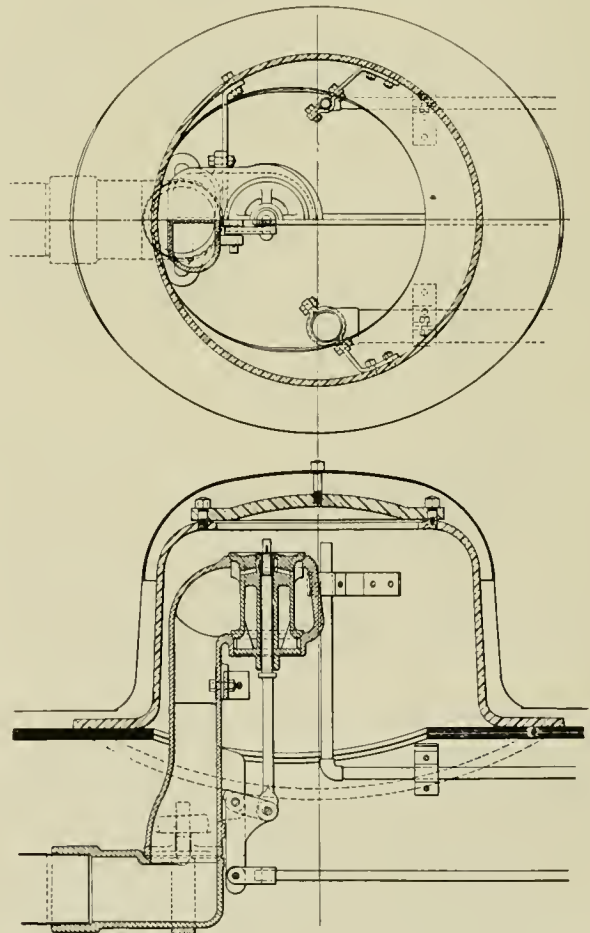

Throttle Arrangement Which Permits Easy Access to the Boiler Through the Dome

the throttle or the standpipe. It will readily be recognized that such an arrangement is of special value in order to reduce the time necessary in carrying out the inspection of boilers to comply with the Interstate Commerce Commission's requirements. On many locomotives not fitted with such an arrangement it is necessary to remove the throttle

and stand pipe from the dome before this inspection can be carried out.

### PISTON VALVE CHAMBER FOR SLIDE VALVE CYLINDERS

The drawing shows a type of piston valve chamber for application to slide valve cylinders which has recently been placed on the market by the G. F. Cotter Supply Company, Houston, Texas. As shown in the drawing the valve chamber is of a straightforward design, being cast in one piece and fitted to the cylinders in place of the slide valve steam chest. It is fitted with a bushing having  $\frac{5}{8}$ -in. walls, which permits reboring several times before renewal of the bushing is necessary.

The steam chest shown in the drawing is designed for use with outside steam pipes, this type generally being desirable

in diameter is 26 in. in length. Peep-holes are provided through the valve chamber walls to facilitate the inspection and the setting of the valves.

The valve spool is a single casting made up of two end rings and a central hub around which is the exhaust cavity. Each of the end rings is fitted with two packing rings of L section.

This steam chest has been in use for several years with both saturated and superheated steam, and it is said to be giving satisfactory service.

### BOILER WALL COATING

The H. W. Johns-Manville Company, New York, has recently brought out a stationary boiler wall coating. The desirability for an easily applied coating was realized because of the fact that imperfect combustion, with its corre-

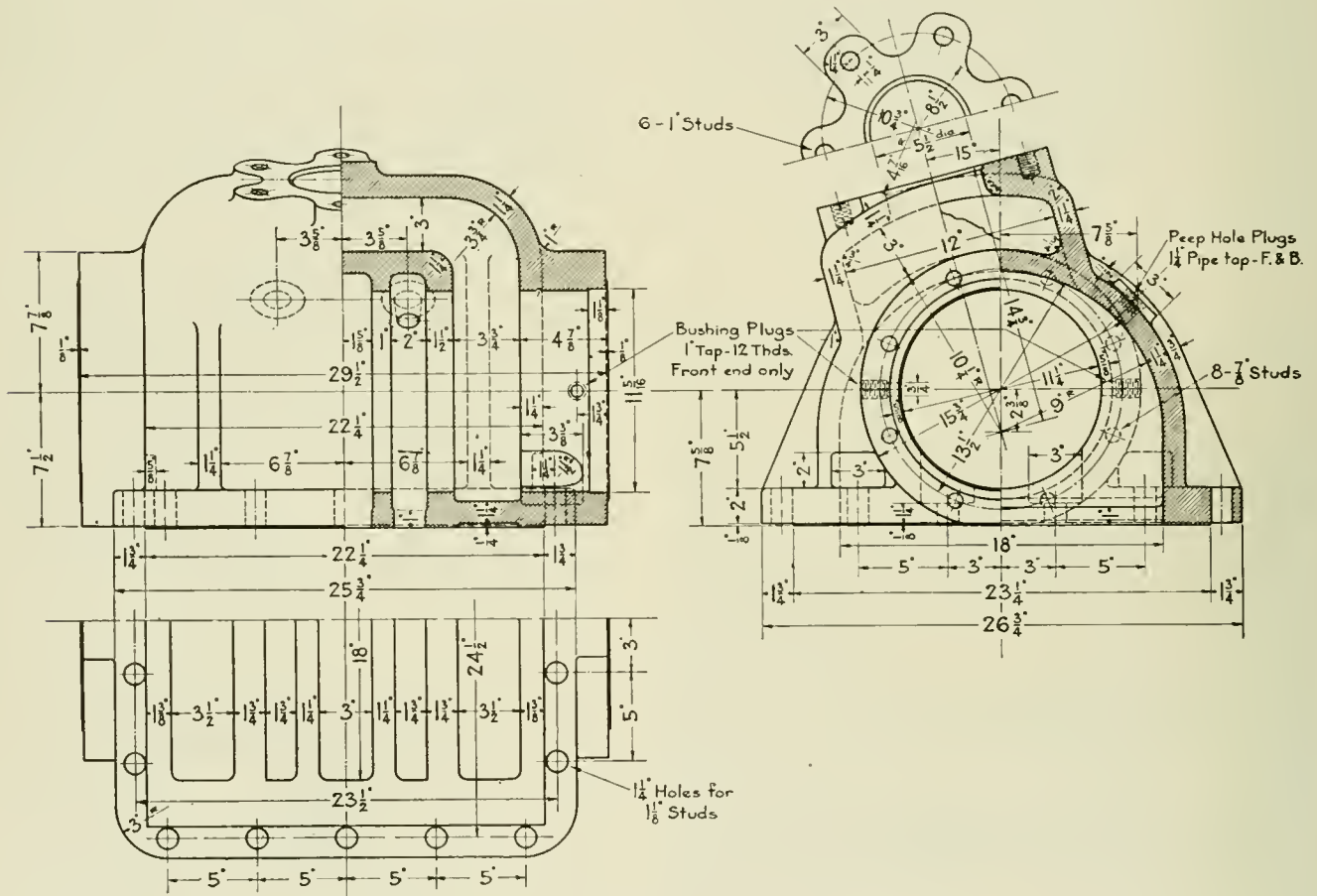

A Simple Piston Valve Chamber for Slide Valve Cylinders

when the locomotive is equipped with a superheater. The smokebox ends of the steam channels in the cylinder saddles are blanked, the valve ends being blanked by the steam chest, and steam is admitted directly through the top of the steam chest. The steam chest is also built for use with the existing steam pipe arrangement generally found on the older locomotives equipped with slide valves. In this case the only work required is the facing of the valve seat, the same stud holes being used and the same valve motion being retained.

The joint between the chest and the seat, is said to easily be kept tight, sufficient stock being provided in the central bridge in chest and bushing to admit the use of a 1-in. stud if desired. Each port is surrounded by a copper wire gasket and special steel holding-downs studs are provided for additional security. The working port area in the case of the 11-in. valve which is used on engines having cylinders up to 22 in.

responding heat loss, is often caused by too much air in firing, and particularly by too much air leaking into the boiler. Each crack in the boiler setting allows air to leak in and mix with the flue gases before perfect combustion takes place; moreover the air which leaks in is cold and uses up heat units which should be developing steam. The result is decreased boiler efficiency.

This product, which is known as J-M Aertite boiler wall coating, is applied to the outside of the boiler wall, and it is claimed that it eliminates air infiltration. It provides a coating over the entire boiler setting which remains tight on account of its adhesive and ductile qualities. It is easily applied by troweling. The best results are obtained by keeping the thickness as near 1/16 in. as possible. The quantity required to cover 100 sq. ft. depends on the number and variety of cracks and the way the wall has been pointed



up. For 1/16 in. thickness it will take approximately 25 to 40 lb. per hundred sq. ft.

A test was conducted at a large power plant in New York City, with the following results:

	Before Appli- cation.	After Appli- cation.
Per Cent of CO <sub>2</sub> in flue gases taken from back of first baffle wall .....	13.5	13.8
Per Cent of CO <sub>2</sub> in flue gases take from back of second baffle wall .....	11.6	13.5

### LOCOMOTIVE CRANE TROLLEY

One of the largest alternating current cranes ever installed for handling locomotives has been furnished recently by the Whiting Foundry Equipment Company, Harvey, Ill., to the Seaboard Air Line for the new shops at Portsmouth, Va. The crane is of 160 tons capacity with two 80-ton trolleys, one of which is equipped with a 10-ton auxiliary hoist.

The trolleys are of the construction shown in the illustration. The entire train of gears is enclosed and runs in an oil bath. The motor pinion has an outboard bearing as shown. The idler sheaves are mounted on a separator, thereby allowing the operator to inspect the rope and oil

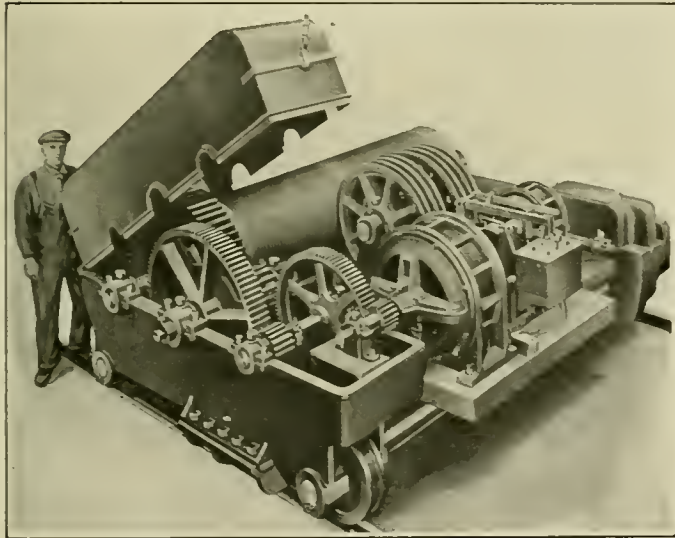

Two-Motor Electric Crane Trolley, Capacity 80 Tons

the sheaves while standing on top of the trolley. This also increases the lift of the crane by about 30 in. With the exception of the drum shaft, no shafts extend across the trolley. All shafts in the gear train are on the same line and are cast steel, machine cut. The pinions are forged, as is the drum gear. The trolley sides and separator are cast steel, the housing being of structural steel, provided with proper hand holes to allow for inspection and easy removal for making repairs.

**ARKANSAS MANGANESE.**—The Arkansas manganese field has been the scene of considerable activity during the last few months in consequence of the rapid advance in the price of ferro-manganese. The deposit is being worked rather crudely by reason of the want at present of concentrating machinery, but the ore, which promises good results from better treatment, is being held for future milling. About 10 cars per week are being despatched, mostly of high-grade ore, yielding in some cases as much as 60 per cent in manganese. The area of the field is 260 square miles.—*Engineering.*

### THE LA ROCK PIPE WRENCH

A pipe wrench of special design and particularly fitted for working pipe where the clearances are limited, has recently been placed on the market by the Mechanical Specialty Company, Peoples Gas Building, Chicago. The construction and application of this wrench to a pipe are shown in the drawings.

It will be noticed that the tongs bear on two-thirds of the circumference of the pipe, which can be worked with a wrench motion of 10 degrees. The wrench is of simple construction, being made up of only three parts, with no screws, springs, pins or ratchets. There are no adjustments to be

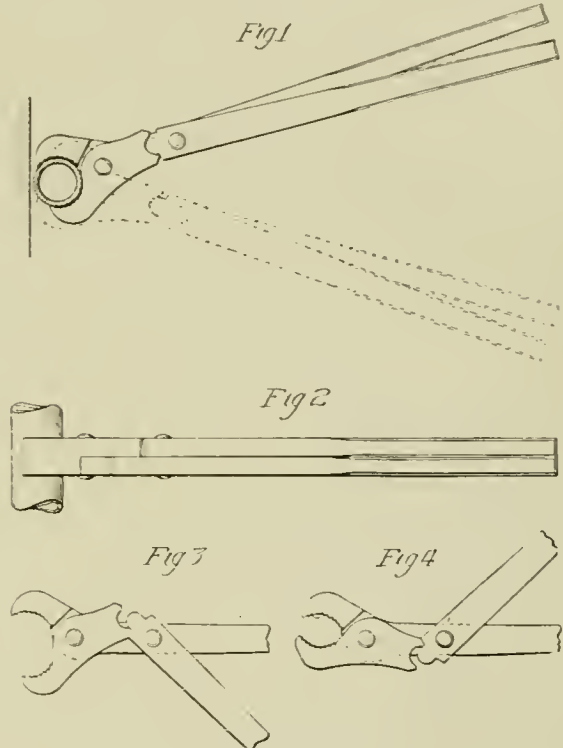

How the Wrench Operates

made and the wrench is always in position to do the work necessary. It comes in four sizes, there being a special size for the 3/8-in., the 1/2-in., the 3/4-in. and the 1-in. pipe. Although each wrench is especially fitted for its own size of pipe, it will satisfactorily work the next smaller and the next larger size. The wrench is made of high-grade, drop forged steel with special steel rivets, and will stand more strain than can be applied by the man using it.

**A BILLION FEET OF LUMBER FROM CALIFORNIA.**—A total of more than a billion feet of lumber was sawed by California mills during 1915, according to statistics compiled by the U. S. Forest Service. The report includes figures from 136 mills, thirty-five of which had cut 90 per cent of the total. Of thirteen kinds of wood sawn, redwood led with a total of 418,824,000 ft. b.m. With the exception of about 1,000,000 ft. b.m., it was all California timber.

**REMOVING OIL FROM LEATHER BELTING.**—Oil can be removed by soaking the belting in baths such as gasoline, for taking up the oil, but the treatment is not recommended unless practiced by expert belt makers, as liquids that dissolve the oil are likely to injure the texture of the leather and loosen the cementing of the laps. In most cases a sufficient quantity of oil can be removed to render the belt serviceable by packing it in dry sawdust for several days.—*Power.*

# Railway Mechanical Engineer

(Formerly the RAILWAY AGE GAZETTE, MECHANICAL EDITION  
with which the AMERICAN ENGINEER was incorporated)

PUBLISHED ON THE FIRST THURSDAY OF EVERY MONTH BY THE  
SIMMONS-BOARDMAN PUBLISHING COMPANY

EDWARD A. SIMMONS, *President*                      L. B. SHERMAN, *Vice-President*  
HENRY LEE, *Vice-President and Treasurer*      M. H. WIUM, *Secretary*  
WOOLWORTH BUILDING, NEW YORK, N. Y.  
F. H. THOMPSON, *Business Manager*, CHICAGO.

Chicago: Transportation Bldg.                      Cleveland: Citizens' Bldg.  
London: Queen Anne's Chambers, Westminster.

ROY V. WRIGHT, *Editor*  
A. C. LOUDON, *Managing Editor*

R. E. THAYER, *Associate Editor*                      C. B. PECK, *Associate Editor*

Entered at the Post Office at New York, N. Y., as mail matter of the second class.

Subscriptions, including the eight daily editions of the *Railway Age Gazette* published in June in connection with the annual conventions of the Master Car Builders' and American Railway Master Mechanics' Associations, payable in advance and postage free: United States, Canada and Mexico, \$2.00 a year; Foreign Countries (excepting daily editions), \$3.00 a year; Single Copy, 20 cents.

WE GUARANTEE, that of this issue 7,600 copies were printed: that of these 7,600 copies, 6,600 were mailed to regular paid subscribers, 102 were provided for counter and news companies' sales, 468 were mailed to advertisers, exchanges and correspondents, and 430 were provided for new subscriptions, samples, copies lost in the mail and office use: that the total copies printed this year to date were 65,200, an average of 8,150 copies a month.

The RAILWAY MECHANICAL ENGINEER is a member of the Audit Bureau of Circulations.

VOLUME 90

AUGUST, 1916

NUMBER 8

## CONTENTS

### EDITORIALS:

The Future of the Brick Arch.....	385
Do Your Locomotives Suit Operating Conditions?.....	385
Hot Boxes on Freight Cars.....	385
Steel Gondola Cars with Wooden Sides.....	385
Triplex Articulated Locomotives.....	386
The Mechanical Department Supply Manufacturer.....	386
Standard Shop Tools.....	386
High Capacity and Low Axle Weight.....	386
Mechanical Conventions in August and September.....	387
New Books.....	387

### COMMUNICATIONS:

Oxy-Acetylene Cylinder Weld.....	388
Grease Lubrication of Locomotive Driving Boxes.....	388

### GENERAL:

Baltimore & Ohio Road Mallets.....	389
Locomotive Firebox Proportions.....	392
Water Treatment on the Missouri Pacific.....	393
An Eight-Wheel English Locomotive.....	395
Heat Treatment of Carbon-Steel Locomotive Axles: Water vs Oil Quenching.....	398
The Use of Pulverized Coal as a Fuel.....	399
A Variable Exhaust Nozzle.....	400

### CAR DEPARTMENT:

Steel Frame Automobile Cars.....	401
The Passenger Car Terminal Yard.....	402
Depressed Aisle Strips.....	402
Freight Car Carpenter Apprentices.....	403
The Need of Uniform Equipment on Freight Cars.....	405
Seventy-Ton Gondola Cars.....	406
Preserving the Life of Steel Cars.....	408
Shrinkage of Box Car Sheathing.....	408
Buffing Stresses in Box Cars.....	409
Interlocking Fenders and Collision Buffers.....	411

### SHOP PRACTICE:

Testing Pneumatic Tools.....	413
Procrastination, the Thief of Time.....	414
A Simple Grease Cup Plug.....	414
Training Boilermaker Apprentices.....	415
Handling a Big Engine Terminal.....	417
Heat Treatment of Steel.....	418
Rivet Cutter for Freight Car Repairs.....	419
Locomotive Piping and Jackets.....	420
The Importance of the Roundhouse Foreman.....	421
The Camera in a Railroad Shop.....	422
Electric Furnaces for Tempering Tools.....	423
Getting Results in an Enginehouse.....	424
Manufacturing Standard Brake Levers.....	425
Some Points in Enginehouse Management.....	426
Ratchet Grease Cup.....	426

### NEW DEVICES:

Fusible Crown Sheet Plug.....	427
Duplex Keyseat Milling and Cottering Machine.....	427
Compressed Air Meter.....	428
Electric Ceiling Fan for Passenger Cars.....	428
The "Gun" Tap.....	429
Arrangement of Throttle and Standpipe.....	429
Piston Valve Chamber for Slide Valve Cylinders.....	430
Boiler Wall Coating.....	430
Locomotive Crane Trolley.....	431
The La Rock Pipe Wrench.....	431

### NEWS DEPARTMENT:

Notes.....	432
Meetings and Conventions.....	433
Personals.....	434
Supply Trade Notes.....	436
Catalogues.....	437

A fire at the shops of the Seaboard Air Line, at Portsmouth, Va., July 6, destroyed the coach shed and ten passenger cars. The estimated loss was \$100,000.

The office of the mechanical superintendent of the Texas & Pacific has been transferred from Marshall, Tex., to Dallas. The jurisdiction of the mechanical superintendent has been extended over the fuel bureau.

### FIRST NEW LARGE STEAMER IN UNITED STATES WITH SUPERHEATER

While there are about 1,500 steamers, representing over 2,000,000 hp., sailing from foreign ports equipped with fire tube superheaters, the recent launching of the Pearl Shell at the ship yards of the Harlan & Hollingsworth Corporation, Wilmington, Del., represents the first installation in a new steamer built in this country.

The Pearl Shell is an oil tanker, is to be operated by the

Shell Oil Company of San Francisco, and will for the present sail out of New York harbor. It is over 400 ft. long, represents a gross tonnage of over 5,600 tons, and is equipped with three Scotch marine boilers fitted with Locomotive Superheater Company fire tube superheaters, supplying superheated steam to triple expansion engines, developing 2,400 hp.

The superheater was applied to the Pearl Shell after the purchasers had determined the economy and reliability in operation of a superheater of the same design, applied to one of their existing steamers of approximately the same size. They have also contracted for sufficient superheater equipment to convert five more of their existing ships.

### CARS AND LOCOMOTIVES ORDERED IN JULY

The high prices of materials and the fact that July is always more or less a quiet month from the standpoint of equipment purchasing kept the orders for cars and loco-

tives during the month at a low figure. The orders for cars and locomotives reported during the month were as follows:

	Locomotives	Freight Cars	Passenger Cars
Domestic .....	24	2,413	46
Foreign .....	27	210	..
	51	2,623	46

Among the locomotive orders reported were the following: Duluth, Winnipeg & Pacific, 10 Consolidation locomotives, American Locomotive Company; Philadelphia & Reading, 10 switching locomotives, company shops, and Central of Brazil, 7 Pacific and 12 Ten-wheel locomotives, American Locomotive Company.

The freight car orders included an order placed by the Duluth, Winnipeg & Pacific with the Haskell & Barker Car Company for 750 box cars. The Chicago, Milwaukee & St. Paul will soon build 1,100 42-ft., 40-ton box cars in its Milwaukee shops. The total of 46 passenger cars was almost entirely made up by 42 all-steel elevated car bodies ordered by the Boston Elevated from the Pressed Steel Car Company.

MEETINGS AND CONVENTIONS

*Master Blacksmiths' Association.*—The twenty-fourth annual convention of the International Railroad Master Blacksmiths' Association will be held at the Hotel Sherman, Chicago, August 15-17, 1916. The following subjects will be discussed: Frame Making and Repairing. Drop Forgings, Tools and Formers. Spring Making and Repairing. Frogs and Crossings, Carbon and High Speed Steels, Case Hardening, Oxy-Acetylene and Electric Welding. Shop Kinks, Heat Treatment of Metals, Piece Work and other Methods, Reclaiming of Scrap Material, Flue Welding.

*American Railway Tool Foreman's Association.*—The convention of the American Railway Tool Foreman's Association will be held on August 24-26, at the Hotel Sherman, Chicago. The following subjects will be presented by the committees: Heat Treatment of Steel, Henry Otto, chairman; Special Tools for Steel Car Repairs—Devices for Reclaiming Material, J. W. Pike, chairman; Special Tools and Devices for the Forge Shop, G. W. Smith, chairman; Emery Wheels as Applied to Locomotive Repairs, A. Sterner, chairman; Jigs and Devices for Enginehouses, F. D. West, chairman.

*International Railway General Foremen's Association.*—The twelfth annual convention of the International Railway General Foremen's Association will be held at the Hotel Sherman, Chicago, on August 29 to September 1, and not in July as formerly. The following is the list of topics with the name of the chairman of the committee which is to prepare them: Car Department Problems, E. E. Griest, chairman; Counterbalancing of the Locomotive and Fitting Up of the Frames and Binders, H. C. Warner, chairman; Classification of Repairs, Robert Wilson, chairman; Relation of the Foreman to the Men, T. E. Freeman, chairman.

*Master Car & Locomotive Painters' Association.*—The next annual convention of the Master Car and Locomotive Painters' Association will be held at Atlantic City, N. J., on September 12-14, 1916. The list of subjects to be presented is as follows: The Initial Treatment and Maintenance of Steel Passenger Equipment Roofs, etc.; Headlinings Painted White or in Very Light Shades—How Should They Be Treated and Should They Be Varnished; Is It Economy to Purchase Paints Made on Railroad Specifications; The Shopping of Passenger Cars for Classified Repairs; Railway Legislation and Its Effect on Business. The following questions will also be discussed: To what extent is it necessary to remove trimmings from passenger car equipment undergoing paint shop treatment? How does the hot water and oil method of cleaning locomotives at roundhouses affect the painted parts? Is there any advantage in painting or oiling the interior of new or old steel gon-

dola and hopper cars? Is there anything superior to varnish remover for removing paint from a steel passenger car, considering labor and material costs? Is there anything superior to soap for the cleaning of passenger equipment cars preparatory to painting and varnishing?

*Traveling Engineers' Association.*—The twenty-fourth annual convention of the Traveling Engineers' Association will be held at the Hotel Sherman, Chicago, commencing September 5, 1916, and continuing four days.

A brief program of the meeting follows:

Tuesday, September 5. Morning session, 10:30 a. m.—Opening exercises and consideration of subject: "What effect does the mechanical placing of fuel in fireboxes and lubricating of locomotives have on the cost of operation?" W. L. Robinson (B. & O.), chairman. Afternoon session, 1:30 p. m.—Continuation of the same subject.

Wednesday, September 6. Morning session, 9 a. m.—"The advantages of superheaters, brick arches and other modern appliances on large engines, especially those of the Mallet type." J. E. Ingling (Erie), chairman. Afternoon session, 1:30 p. m.—Committee on subjects for discussion at the 1917 meeting. B. J. Feeny (I. C.), chairman. Evening—The entire evening will be devoted to studying and examining the exhibits.

Thursday, September 7. Morning session, 9 a. m.—"Difficulties accompanying the prevention of dense black smoke and its relation to cost of fuel and locomotive repairs." Martin Whelan (C. C. C. & St. L.), chairman. Afternoon session, 1:30 p. m.—"Recommended practice in the makeup and handling of modern freight trains on both level and steep grades, to avoid damage to draft rigging." L. R. Pyle (Soo Line), chairman.

Friday, September 8. Morning session, 9 a. m.—"Assignment of power from standpoint of efficient service and economy in fuel maintenance." P. O. Wood (St. L. & S. F.), chairman. Afternoon session, 1:30 p. m.—"Standing committee on revision of progressive examinations for firemen for promotion and new men for employment." W. H. Corbett (M. C.), chairman. Committee report on change of constitution and by-laws. J. C. Petty (N. C. & St. L.), chairman. Election of officers. Adjournment.

The following list gives names of secretaries, dates of next or regular meetings and places of meeting of mechanical associations:

- AIR BRAKE ASSOCIATION.—F. M. Nellis, Room 3014, 165 Broadway, New York City.
- AMERICAN RAILROAD MASTER TINNERS', COPPERSMITHS' AND PIPEFITTERS' ASSOCIATION.—O. E. Schlink, 485 W. Fifth St., Peru, Ind.
- AMERICAN RAILWAY MASTER MECHANICS' ASSOCIATION.—J. W. Taylor, Karpen Building, Chicago.
- AMERICAN RAILWAY TOOL FOREMEN'S ASSOCIATION.—Owen D. Kinsey, Illinois Central, Chicago. Convention, August 24-26, 1916.
- AMERICAN SOCIETY FOR TESTING MATERIALS.—Prof. E. Marburg, University of Pennsylvania, Philadelphia, Pa.
- AMERICAN SOCIETY OF MECHANICAL ENGINEERS.—Calvin W. Rice, 29 W. Thirty-ninth St., New York.
- ASSOCIATION OF RAILWAY ELECTRICAL ENGINEERS.—Joseph A. Andreacetti, C. & N. W., Room 411, C. & N. W. Station, Chicago.
- CAR FOREMEN'S ASSOCIATION OF CHICAGO.—Aaron Kline, 841 Lawlor Ave., Chicago. Second Monday in month, except June, July and August, Hotel La Salle, Chicago.
- CHIEF INTERCHANGE CAR INSPECTORS' AND CAR FOREMEN'S ASSOCIATION.—W. R. McMunn, New York Central, Albany, N. Y. Convention, October 3-5, Indianapolis, Ind.
- INTERNATIONAL RAILROAD MASTER BLACKSMITHS' ASSOCIATION.—A. L. Woodworth, C. H. & D., Lima, Ohio. Convention, August 15-17, 1916, Hotel Sherman, Chicago.
- INTERNATIONAL RAILWAY FUEL ASSOCIATION.—J. G. Crawford, 547 W. Jackson Blvd., Chicago. Convention May, 1917, Chicago.
- INTERNATIONAL RAILWAY GENERAL FOREMEN'S ASSOCIATION.—William Hall, 1126 W. Broadway, Winona, Minn. Convention, August 29-Sept. 1, 1916, Hotel Sherman, Chicago.
- MASTER BOILER MAKERS' ASSOCIATION.—Harry D. Vought, 95 Liberty St., New York.
- MASTER CAR BUILDERS' ASSOCIATION.—J. W. Taylor, Karpen Building, Chicago.
- MASTER CAR AND LOCOMOTIVE PAINTERS' ASSOCIATION OF U. S. AND CANADA.—A. P. Dane, B. & M., Reading, Mass. Convention, September 12-14, 1916, "The Breakers," Atlantic City, N. J.
- NAGARA FRONTIER CAR MEN'S ASSOCIATION.—E. N. Frankenberger, 623 Brisbane Building, Buffalo, N. Y. Meetings, third Wednesday in month, New York Telephone Bldg., Buffalo, N. Y.
- RAILWAY STOREKEEPERS' ASSOCIATION.—J. P. Murphy, Box C, Collinwood, Ohio.
- TRAVELING ENGINEERS' ASSOCIATION.—W. O. Thompson, N. Y. C. R. R., Cleveland, Ohio. Convention, September 5-8, 1916, Hotel Sherman, Chicago.

## PERSONAL

### GENERAL

DAN G. CUNNINGHAM has been appointed superintendent of motive power of the Denver & Salt Lake at Denver, Colo. Mr. Cunningham was born at Roanoke, Va., on April 19, 1873, and was educated in the public schools of his native city, and at the Virginia Polytechnic Institute, graduating from the latter institution in 1898. He entered railway service in 1890 as a machinist apprentice in the Roanoke shop of the Norfolk & Western. From 1898 to June, 1900, he was employed as a machinist in the same place. He then entered the service of the Atchison, Topeka & Santa Fe as general foreman at Needles, Cal., returning to the Norfolk & Western in 1904, as roundhouse foreman at Portsmouth, Ohio. From 1907 to March 10, 1912, he was general foreman of the same road at Williamson, W. Va. From March 20, 1912, to June 30, 1916, he was superintendent of shops of the Denver & Rio Grande at Salt Lake City, Utah, which position he held at the time of his recent appointment as noted above.



D. G. Cunningham

ELIOT SUMNER, who has been appointed superintendent of motive power of the Pennsylvania Railroad, with headquarters at Williamsport, Pa., as was announced in the July *Railway Mechanical Engineer*, was born on October 18, 1873, at New Haven, Conn. He attended Yale University, and in 1896 entered the service of the Pennsylvania Railroad as an apprentice at the Altoona (Pa.) machine shop. In February, 1901, he was appointed inspector on the Philadelphia division, and the following October was made assistant master mechanic of the Middle and Western divisions. He was promoted in 1902 to assistant engineer of motive power on the Buffalo and Allegheny Valley division, and the following year was transferred to the office of the general superintendent of motive power. In 1907, he was appointed master mechanic on the Baltimore division, and in 1911 was transferred in the same capacity to the Williamsport division. On December 1, 1913, he was appointed master mechanic at the west Philadelphia shops, which position he held at the time of his recent appointment as superintendent of motive power of the same road at Williamsport, as above noted.



E. Sumner

A. J. WAGAR, chemist of the Buffalo, Rochester & Pitts-

burgh, has been appointed chemist of the Louisville & Nashville at Louisville, Ky.

F. W. WILSON, formerly road foreman of equipment of the Chicago, Rock Island & Pacific at Rock Island, Ill., has been appointed engineer of fuel economy at Chicago, succeeding H. Clewer, promoted.

### MASTER MECHANICS AND ROAD FOREMEN OF ENGINES

H. CLEWER, engineer of fuel economy of the Chicago, Rock Island & Pacific at Chicago, has been appointed master mechanic of the Missouri division, with office at Trenton, Mo., succeeding E. J. Harris, resigned.

CHARLES W. EXTRAND has been appointed acting road foreman of engines of the Northern Pacific, with headquarters at Northtown, Minn.

WILLIAM F. HEISER, master mechanic of the Chicago & Eastern Illinois, has been transferred to Danville, Ill., succeeding W. R. Meeder, transferred.

W. H. KELLER, general foreman of shops of the Texas & Pacific, at Fort Worth, Tex., has been appointed master mechanic of the eastern division at Marshall, Tex., with jurisdiction extending over the shops at Texarkana, Tex.

WILLIAM R. MEEDER, master mechanic of the Chicago & Eastern Illinois at Danville, Ill., has been transferred to Villa Grove, succeeding R. N. Kincaid, resigned.

JOHN F. MULLEN has been appointed assistant master mechanic of the Buffalo, Rochester & Pittsburgh at Buffalo Creek, N. Y. Mr. Mullen was born at Oswego, N. Y., and after graduating from the Oswego High School took a business course in Oswego College. He entered railway work as a machinist with the Delaware, Lackawanna & Western, later going to the Rome, Watertown & Ogdensburg (now a part of the New York Central) as stenographer and time-keeper. In 1890 he entered the service of the Buffalo, Rochester & Pittsburgh as machinist, and was later made gang foreman. He was the first gang foreman appointed at the general shops at Dubois, Pa., and in 1905 was made general foreman at Buffalo, N. Y., which position he held at the time of his present appointment as assistant master mechanic.

H. G. REID, heretofore master mechanic of the Saskatchewan division of the Canadian Pacific at Moose Jaw, has been appointed master mechanic, District 3, of the National Transcontinental at Transcona, Man., succeeding J. Birse, transferred.

D. W. ST. CLAIR has been appointed master mechanic of the Missouri, Oklahoma & Gulf of Texas at Denison, Tex., succeeding J. R. Greiner, resigned.

A. W. STANDIFORD, general foreman of the Chicago & Eastern Illinois at Salem, Ill., has been appointed master mechanic at Evansville, Ind., succeeding W. F. Heiser.

A. WEST has been appointed district master mechanic, District 4, Canadian Pacific at Edmonton, Alta., succeeding A. J. Ironsides, transferred.

### CAR DEPARTMENT

W. J. ALLEN has been appointed leading painter of the Canadian Pacific at West Toronto, succeeding T. Marshall, transferred to Angus shops, Montreal.

M. D. JORDAN, formerly in the car department of the Canadian Pacific at Vancouver, B. C., has been appointed car foreman at Field, B. C., succeeding C. J. Crozier, transferred.

C. A. MUNRO, formerly car foreman of the Grand Trunk Pacific at Melville, Sask., has been appointed car foreman at Edmonton, Alta., succeeding W. Silverwood, transferred.

H. REID has been appointed car foreman of the Grand Trunk Pacific at Rivers, Man.

W. SILVERWOOD, formerly car foreman of the Grand Trunk Pacific at Edmonton, Alta., has been appointed car foreman at Melville, Sask., succeeding C. A. Munro, transferred.

W. S. STILLWELL has been appointed car foreman of the National Transcontinental at Graham, Ont., succeeding G. E. Decker, resigned.

G. W. WILSON has been appointed car foreman of the Grand Trunk Pacific at McBride, B. C., succeeding C. McKinnon, who has enlisted.

#### SHOP AND ENGINE HOUSE

F. W. BEHAN, formerly erecting shop foreman of the Grand Trunk Pacific at Transcona, Man., has been appointed locomotive foreman at Regina, Sask.

J. DODD has been appointed assistant locomotive foreman of the Canadian Pacific at Lambton, Ont., succeeding J. Tregaskis, promoted.

E. J. HARRIS, master mechanic of the Chicago, Rock Island & Pacific at Trenton, Mo., has been appointed shop superintendent of the Denver & Rio Grande, at Salt Lake City, Utah, succeeding D. G. Cunningham, resigned.

G. C. HEARTS, formerly erecting shop foreman of the Canadian Northern at Trenton, Ont., has been appointed locomotive foreman at Toronto, succeeding S. L. Tracey.

EDWARD F. HOUGHTON has been promoted to superintendent of shops of the Buffalo, Rochester & Pittsburgh at East Salamanca, N. Y., succeeding J. F. Mullen, promoted.

JAMES MEDLAND has been promoted to foreman of the Buffalo, Rochester & Pittsburgh at Clarion Junction, Pa., succeeding E. F. Houghton.

D. E. SMITH, formerly locomotive foreman of the Grand Trunk Pacific at Regina, Sask., has been appointed locomotive foreman at Prince Rupert, B. C.

J. TREGASKIS, formerly assistant locomotive foreman of the Canadian Pacific at Lambton, Ont., has been appointed night locomotive foreman there, succeeding S. Illingsworth, transferred.

#### PURCHASING AND STOREKEEPING

R. H. ADAMS has been appointed assistant purchasing agent of the San Pedro, Los Angeles & Salt Lake at Los Angeles, Cal.

G. E. COTTON has been appointed storekeeper of the Cincinnati, Hamilton & Dayton at Ivorydale, Ohio.

G. T. INCOLD has been appointed storekeeper of the Baltimore & Ohio lines at New Castle Junction, Pa.

J. C. McCAUGHAN has been appointed storekeeper of the Baltimore & Ohio at Glenwood, Pa., succeeding O. V. McQuilkin, promoted.

O. V. McQUILKIN, storekeeper of the Baltimore & Ohio at Glenwood, Pa., has been appointed district storekeeper, succeeding L. H. Tutwiler, transferred to the accounting department.

WILLIAM G. O'FALLON has been appointed purchasing agent of the Terminal Railroad Association of St. Louis, succeeding J. E. Williams, Jr.

ISAAC B. THOMAS, who has been appointed assistant purchasing agent of the Pennsylvania Railroad, with office at Philadelphia, Pa., as was announced in the July *Railway Mechanical Engineer*, was born on June 26, 1872, at West Chester, Pa., and was educated at Friends' High School and at Haverford Grammar School. He graduated from Sheffield

Scientific School, Yale University, in 1892, and later in the same year entered the service of the Pennsylvania Railroad as an apprentice at the Altoona (Pa.) shops. In August, 1897, he was appointed inspector of the same shops, and in April, 1899, became inspector in the office of the assistant engineer of motive power of the same road at Altoona. He was appointed assistant master mechanic at Renovo, Pa., in February, 1900, and in October, 1901, became assistant engineer of motive power at Altoona. He remained in that position until August, 1903, when he became master mechanic at Pittsburgh, and was transferred as master mechanic in February, 1906, to the Altoona machine shops. On May 1, 1911, he was promoted to superintendent of motive power of the Erie division (now the Central division) of the same road, and of the Northern Central at Williamsport, Pa., which position he held at the time of his recent appointment as assistant purchasing agent of the Pennsylvania Railroad, as above noted.

#### OBITUARY

C. L. BUNDY, general foreman passenger car repairs of the Delaware, Lackawanna & Western at Kingsland, N. J., died of heart failure on July 2, 1916. Mr. Bundy began his business career at the age of 19 with the Missouri Car & Foundry Company at St. Louis, Mo., and later went to the United States Rolling Stock Company (now a part of the Western Steel Car & Foundry Company) at Hegewisch, Ill. He then entered the railroad field, taking charge of the division shops of the Chicago, Rock Island & Pacific at Trenton, Mo. He was made general foreman of the shops at Davenport, Iowa, and in 1897 was appointed traveling general foreman of the entire car department at Chicago, Ill. He left this position to take charge of the mechanical department of the Swift Refrigerator Line and after two years in this position he went with the Delaware, Lackawanna & Western at Dover, N. J. He then went to the Colorado Southern as general foreman at Denver, Colo. After a few months he returned to the Delaware, Lackawanna & Western as general foreman of shops at Keyser Valley, Scranton, Pa., which position he resigned to accept service with the Hicks Locomotive & Car Works as superintendent of the coach department. In 1908 he again returned to the Delaware, Lackawanna & Western as general foreman, passenger car repairs, at Kingsland, N. J.

A. J. COTA, division master mechanic of the Chicago, Burlington & Quincy, lines east of the Missouri river, with office at Chicago, died at his home in La Grange, Ill., on July 9.

THOMAS J. HUTCHINSON, formerly master car painter of the Grand Trunk at London, Ont., and past president of the Master Car and Locomotive Painters' Association, died June 10, at his home in London, Ont. Mr. Hutchinson had been in the railway painting trade since 1887, being in the employ of the Grand Trunk for all but about three years from that time to the time of his retirement, May 1, 1914. He was a veteran of the Civil war.

THOMAS E. LEWIS, locomotive inspector of the Norfolk & Western, died on July 16, at the home of his brother, W. H. Lewis, superintendent of motive power of the same road, at Roanoke, Va. He was born on January 11, 1836, in Devonshire, England, and in 1857 entered the service of the New York Central as machinist and foreman at Syracuse, N. Y. He subsequently served as master mechanic on the Hannibal & St. Joseph, and on the Union Pacific. He was superintendent and master mechanic of the Kansas City Elevated Railway and then was master mechanic on the Kansas City, Wyandotte & Western. In 1898 he was appointed inspector of locomotives on the Norfolk & Western.

FRED H. WHITE, purchasing agent of the Duluth, Missabe & Northern, died on July 17, at Duluth, Minn., following a two weeks' illness after an operation for carbuncles.

## SUPPLY TRADE NOTES

The International Oxygen Company, New York, is installing a new plant at College Point, L. I., for the manufacture of oxygen and hydrogen gas.

Henry Alden Sherwin, chairman of the board of directors of the Sherwin-Williams Company, died of heart failure on June 26, at his country place, near Cleveland, Ohio.

R. N. Kincaid, formerly master mechanic of the Chicago & Eastern Illinois at Villa Grove, Ill., has become associated with the Buick Automobile Company at Flint, Mich.

M. T. Kirschke, sales representative of the Baldwin Locomotive Works, with headquarters at Chicago, Ill., died at his home in that city on July 18, after an illness of several weeks.

W. G. Cook, who was recently appointed assistant to the general sales manager of the Garlock Packing Company, has been appointed manager of the Chicago branch of the company.

Willard Wilson, assistant manager of sales of the Tennessee Coal, Iron & Railroad Company, has been appointed general manager of sales of the company, succeeding F. A. Burr, who has left the company to become general manager of sales of the Aetna Explosives Company.

R. J. Himmelright, assistant to the manager of the service department of the American Arch Company, has been appointed manager of that department, succeeding J. T. Anthony, promoted.

Mr. Himmelright was born in Barberton, Ohio, in 1883. After completing the common and high school courses there, he took a summer course of two years at Kentucky State University. In 1904 he entered the employ of the Stirling Boiler Company. One year later he entered Purdue University, and graduated in the class of 1909 with the degree of mechanical engineer. He immediately entered the service of the Lake Shore & Michigan Southern as special apprentice, and after serving two years in this capacity was employed by the Locomotive Stoker Company as mechanical expert. This position he held until 1913, when he entered the service of the American Arch Company as traveling engineer. In 1915 he was made assistant to the manager of the service department.

W. H. Ivers, formerly with the Baldwin Locomotive Works, has been appointed southwestern representative of the Gold Car Heating & Lighting Company, New York, with headquarters at St. Louis, Mo., succeeding George F. Ivers, who has resigned to become manager of the railway supply department of the Shapleigh Hardware Company, St. Louis, Mo.

The Goodyear Tire & Rubber Company, Akron, Ohio, has presented to Battery B, Ohio Field Artillery, stationed at Akron, a fully equipped military kite balloon, which is the first of its kind ever owned by the national guard of any state. The balloon is similar to the one recently delivered to the United States Navy for use at the naval aeronautic station at Pensacola, Fla. It was designed and made en-

tirely in the Goodyear factory. The Goodyear Tire & Rubber Company recently sent an aeronautic expert abroad to make a scientific study of kite balloon development to be better able to assist the United States government in building up its aeronautic service.

J. T. Anthony, manager of the service department of the American Arch Company, New York, has been appointed assistant to the president. Mr. Anthony was born in February, 1883. After completing a common and high school course, he entered the Georgia School of Technology, from which he graduated in 1902. He was then engaged in the textile manufacturing business for four years, but in 1906 entered railway service in the roadway department of the Atlantic Coast Line. He remained with that road until 1907, when he became a draftsman in the motive power department of the Central of Georgia. In January, 1912, he entered the employ of the American Arch Company as combustion engineer. In March, 1914, he was made assistant general eastern sales manager. A few months later he was made manager of the service department, in direct charge of traveling engineers and the supervising of all road work. It is this position he leaves to take up his new duties as assistant to the president.

Oscar F. Ostby, until recently general sales agent of the Commercial Acetylene Railway Light & Signal Company, has been appointed general manager of the Refrigerator, Heater & Ventilator Car Company, St. Paul, Minn. Mr. Ostby is very well known in the railway supply field. He has been particularly active in the work of the Railway Supply Manufacturer's Association, having been vice-president of the association in 1914-1915, and its president in the year just ended. He has also been active in the International Acetylene Association, having been a director and vice-president and in 1909-1910 its president. As the chairman of the association's legislative committee, he led the fight against the passage in several states of headlight laws requiring the use of electric equipment only. He was born March 5, 1883, and received his education in the public schools of Providence, R. I. From 1901 to November, 1904, he engaged in publicity work. He then entered the service of what was later the Commercial Acetylene Railway Light & Signal Company, and at the time of his resignation on June 1 of this year was the general sales manager of the company.



J. T. Anthony



R. J. Himmelright



O. F. Ostby

## CATALOGUES

**OIL ENGINES.**—The National Transit Pump & Machine Company, Oil City, Pa., in Bulletin No. 502 describes the National Transit, 4-cycle Diesel oil engine, type DH4A.

**TURRET LATHES.**—One of the recent publications of the International Machine Tool Company, Indianapolis, Ind., deals with the "Libby" heavy duty turret lathe in railroad shops. The booklet contains illustrations of the lathes, and gives operating records dealing with their work in railroad shops.

**LOCOMOTIVE APPLIANCES.**—The G. F. Cotter Supply Company, Houston, Tex., general sales agents for the Simplified Steam Chest Company of the same city, has issued a folder relative to the simplified piston valve steam chest for supplying slide valve locomotives with piston valves for use with superheated steam.

**LOCOMOTIVE CRANES.**—The Brown Hoisting Machinery Company, Cleveland, Ohio, has just issued a booklet of 64 pages, which describes in detail its locomotive cranes and the various attachments which may be added for special uses. The book is illustrated with over 125 photographs showing this type of equipment engaged in a wide variety of operations.

**BUMPING POSTS.**—The Railway and Traction Supply Company, Chicago, has issued a 56-page catalog illustrating installations of the Hercules steel bumping post, the Little Giant bumping post, the Weatherson nut lock and the Wyoming vacuum track sander. One interesting feature is the account of the special Hercules bumping posts installed on the Panama canal locks for the towing locomotives.

**GENERATOR COOLING AND CLEANING.**—This is the title of a booklet which has been recently issued by the Carrier Air Conditioning Company, Buffalo. It describes the Carrier Generator Cooler, and the advantages to be gained by cooling and cleaning the air supply for ventilation of turbo generators. The booklet is illustrated, and special attention is paid to a description of the non-clodding type of spray nozzles.

**PRESSED STEEL CONSTRUCTION.**—The Trussed Concrete Steel Company, Youngstown, Ohio, has issued a 24-page booklet, describing the Kahn pressed steel joists and studs with Hy-rib for floors, roofs, walls and partitions. This book describes in detail and illustrates the methods of construction for which this material is adapted. It also contains a number of photographs of installations and of methods of application.

**PYROMETERS.**—The Gill Instrument Company, Pittsburgh, Pa., has issued a folder relative to the "I-Rite" pyrometer for judging the temperature of metal undergoing treatment. The "I-Rite" is an instrument in appearance much like a pocket flashlight. The person using it stands some distance from the furnace, and looks through it at the object whose temperature is to be determined. A description of it appeared in the May, 1916, *Railway Mechanical Engineer*, page 262.

**TRAIN CONTROL.**—The Miller Train Control Corporation, Staunton, Va., has published a 16-page booklet entitled, "Miller Train Control," which includes a brief resumé of the development of this device, a description of its operation, a record of its installation and the service which it is rendering on the Chicago & Eastern Illinois and a brief comment on the place of the automatic stop in modern railway operation. The booklet is handsomely bound in black leather and artistically illustrated.

**STORAGE BATTERIES.**—The Edison Storage Battery Company has prepared a new booklet on its storage battery, and this was distributed the first day of the M. C. B. convention.

This booklet is considerably more elaborate than any issued in the past. It is profusely illustrated, and contains a simple and concise explanation of the chemical action taking place in the Edison battery on charge and discharge. It also gives complete data on train lighting batteries, which will be of interest to railroad officers.

**GRAPHITE FOR CYLINDER LUBRICATION.**—A booklet recently issued by the Joseph Dixon Crucible Company, Jersey City, N. J., bears the title of "Graphite for Cylinder Lubrication." The booklet tells of graphite lubrication for both steam and gas cylinders and gives facts about lubricators made by various companies to use graphite alone or with oil. Data is given also concerning the saving possible with graphite lubrication, a saving of 50 per cent being asserted as possible with the proper use of flake graphite lubrication.

**STEAM HAMMERS.**—The National Hoisting Engine Company, Harrison, N. J., has issued a 20-page catalogue describing the National steam pile hammer. The booklet contains tables giving the dimensions and other characteristics of the five sizes of these hammers and is illustrated with photographs showing the hammers in use on various kinds of construction work. A 12-page pamphlet has also been issued describing the steam hammers No. 6 and No. 7, weighing 650 and 150 lb. respectively, which are designed especially for use in driving wood and steel sheet piling.

**PULVERIZED FUEL.**—Bulletin 1 of the Locomotive Pulverized Fuel Company, New York, bears the title Pulverized Fuel for Locomotives. On the first page is shown an illustration of the Delaware & Hudson Consolidation locomotive equipped for burning pulverized coal which was exhibited at the Atlantic City conventions. The various sections of the bulletin deal respectively with the following subjects: specification for pulverized fuel; combustion of pulverized fuel; the locomotive fuel bill; advantages to be obtained by the use of pulverized fuel in locomotives, etc.

**THE HISTORY OF THE PLANER.**—This is the title of an attractive booklet which has recently been issued by the Cincinnati Planer Company, Cincinnati, Ohio. The booklet is a study of contrasts, there being shown on facing pages examples of the early and earliest planers and examples of the modern planers now forming part of the company's line. The latter part of the booklet also compares machines made by the Cincinnati Planer Company in its earlier days with the same class of machines which it now makes, the accompanying reading matter explaining wherein the most important improvements have been made.

**COAL AND ASHES GATES.**—C. W. Hunt Company, Inc., West New Brighton, N. Y., has recently issued catalogue No. 15-3 relative to the Hunt coal and ashes gates. The catalogue is of the standard 6 in. by 9 in. size. It contains illustrations and complete descriptions of the company's standard types of gates or valves for controlling the flow of bulk materials. The dimensions are given of those which are more frequently used in power house and storage pocket design. The illustrations showing the application of these valves are selected with the idea of assisting where there is any question as to the type best suited to the requirements.

**POTENTIOMETER SYSTEM OF PYROMETRY.**—This is the title of a booklet recently issued by the Leeds & Northrop Company, Philadelphia. The potentiometer pyrometer is based upon the use of the thermocouple, but differs from the ordinary deflection galvanometer or millivoltmeter pyrometer in that the electromotive force resulting from the difference in temperature between the hot and cold ends of the thermocouple is measured by a novel balancing method rather than by a deflecting galvanometer. The potentiometers employed are of two general types, hand adjusted indicators and automatically adjusted recorders. The recorders are of the single-point curve-drawing class and of the multiple-point

printing class, the latter being supplied for keeping records of the temperatures of as many as 16 different thermocouples.

**ENGINE INDICATORS.**—The Trill Indicator Company, Corry, Pa., has issued a new 56-page booklet on engine indicators and indicating. The construction and purpose of the several parts of both the outside and enclosed spring types of indicators, including indicator reducing motion, are described in detail and well illustrated. Detailed instructions are given on the application and use of the indicator and the planimeter. There are 15 pages illustrating and discussing the characteristic diagrams of the several types of engines including the new Poppet valve type, the Uniflow engine, the high compression two cylinder oil engine and the Diesel engine.

**AIR COMPRESSORS.**—The Ingersoll-Rand Company has issued two new bulletins describing recent designs of air compressors. Form No. 3026 describes the Ingersoll-Rogler Class "Pre" Air Compressor, which is designed for high speed to permit the use of the moderate priced motors obtainable where high speed can be used. This has necessitated the use of special provisions in the way of lubrication and valves which are efficient at high speed. Form No. 3312 describes the "Imperial XB2" Two Stage Air Compressor, which is an all around machine of moderate cost. The bulletins are amply illustrated and describe the features of the machines in detail.

**HOPPER DOOR MECHANISM.**—The United States Metal & Manufacturing Company, New York, has recently issued a folder descriptive of the Dunham hopper door device. The Dunham mechanism gives a positive lock. In locking, the oscillating point or upper link pin of the shaft arm passes beyond the pivotal point or point of support of the shaft arms, the door connecting links resting on a stop when the oscillating point has reached a given distance beyond the pivotal center. The resultant pull is hence below or beyond the point of support, and the greater the load applied to the doors the more positive the lock. The folder has half-tone and line illustrations showing the mechanism applied to gondola and self-clearing hopper cars.

**OIL FILTERS.**—Bulletin No. 5, bearing the title of "Oil Filters," recently issued by the Richardson-Phenix Company, Milwaukee, Wis., describes a complete line of filters for purifying lubricating oil, having capacities of from 25 gallons per day to 50,000 gallons per hour. The catalog is very complete and describes some interesting large size filters for use in purifying lubricating oil from water wheel thrust bearings, large gas and steam engines in steel mills and also for purifying cutting lubricants. The catalog also serves to indicate the advance made in recent years in the science of oil filtration and shows how scientific principles are employed in the small as well as the large size filters. The large filters are made of heavy steel plate, the oil connections into some of them being for 10 in. pipe.

**DU PONT PRODUCTS.**—The Du Pont companies have recently issued a 111 page book, 5 in. by 8 in. in size, giving a complete list of the products made by E. I. Du Pont de Nemours & Co., the Du Pont Fabrikoid Company, the Du Pont Chemical Company and the Arlington Company. The book contains list of products arranged under the following heads: high explosives; low explosives; black blasting powder; sporting powders; explosives for military uses; miscellaneous commodities; blasting supplies; Fabrikoid; chemicals; Pyralin; special products and by-products. In each case a brief description of the commodity is given, followed by a list of its users and also its uses. In a section headed customers, are given the names of all kinds of users alphabetically arranged followed in each case by a list of commodities available for that particular industry. The book itself is bound in Fabrikoid.

**CAR WHEELS.**—The American Steel Foundries have issued an attractive catalogue descriptive of the Davis steel wheels made by the company. The booklet names the advantages of the Davis one-wear steel wheel asserting that, "It retains the advantages of the cast iron wheel—a hardened tread and flange, a softer plate and hub, and a one-wear construction" and in addition is stronger, is of less weight, has absolute rotundity because of its ground treads and has a lower maintenance cost on account of fewer removals for common wheel defects. The booklet is well illustrated, there being given sections, pictures of the wheels, and a number of views, some in colors, showing the manufacture. One section deals with wheels for electric railway service and another gives comparative data of Davis and other wheels.

**TELEPHONE APPARATUS.**—The Western Electric Company has recently issued Catalogue No. 3 of telephone apparatus and supplies containing in its 400 pages illustrations, descriptions, specifications and list prices of its complete line of telephones and accessories. The listings include everything that is needed by telephone companies for the inside and outside plant—telephones, switchboards, power plants, cable, line construction tools, line construction materials and miscellaneous telephone apparatus. The listings include all types of equipment that are in common use. The book contains, further, complete descriptions, circuit diagrams and directions for use. The Western Electric Company has also lately issued the section of the catalogue dealing with interphones in a separate 60-page catalogue bearing the title: Western Electric Interphones and Accessories.

**HEAT INSULATION FOR STEAM LINES AND BOILERS.**—The Armstrong Cork & Insulation Company, Pittsburgh, Pa., has recently issued an 84 page book, entitled Nonpareil High Pressure Covering for Heated Surfaces, treating in great detail of the subject of insulation for high pressure and superheated steam lines. The first few pages of the book consider the requirements for this kind of insulation. Pages 7 to 21 are devoted to a series of comparative tests made at the company's Beaver Falls factory. As a result of these tests the company has been able to fix definitely the heat losses from various sizes of pipe, both covered and uncovered. These losses are given in B. t. u. units per lineal foot, per degree difference in temperature for 24 hours, and are tabulated on pages 41 and 42. On page 45, there are also given tables which show, in a general way, the most economical thicknesses of Nonpareil high pressure covering to use, based on different steam costs. A complete set of specifications, covering the correct installation of these various thicknesses of covering, is given on pages 65 to 78. The book is well bound in board and is well illustrated with half tones and line drawings.

**AIR COMPRESSORS, WATER DRILLS, ETC.**—The Ingersoll-Rand Company, New York, has recently issued three bulletins, designated respectively, Forms 3036, 3029 and 4120. Form 3036 deals with turbo blowers. These blowers are suitable for any air service where the capacity requirements range from 3,000 to 35,000 cu. ft. of free air per minute at pressures of 1 to 2½ lb., and are particularly adapted for such work as foundry cupola blowing; atomizing oil for oil burners; supplying blast to various kinds of heating and annealing furnaces; blowing air for water gas generators; pneumatic conveying systems and for ventilating purposes. Form 3029 describes the "Ingersoll-Rogler" Class "ORC" Corliss steam driven air compressors of the duplex type, with the steam cylinders next to the frames and separated from the air cylinders by open distance pieces. This type of machine is offered in four different combinations of cylinders. The catalogue gives sizes and capacities. Form 4120 describes the Leyner-Ingersoll water drills of both the No. 18 and No. 26 type. It explains the construction in detail, and illustrates the different types.



# Railway Mechanical Engineer

Volume 90

September, 1916

No. 9

## Strike Hastens Publication

Publication of this issue was rushed when it became evident early in the last week of August that a general railroad strike was imminent. It was feared that if publication was deferred until the usual time the entire issue might be held up in the mails for an indefinite period. Because of this hurried publication it was impossible to include very much of the proceedings of the convention of the International Railway General Foremen's Association, although we had made special arrangements to publish a full account of it in this issue. The remainder of the proceedings of this meeting will be fully covered in our October number. Meanwhile complete accounts of the annual conventions of the International Railroad Master Blacksmiths' Association and the American Railway Tool Foremen's Association will be found in this number. As noted elsewhere, the annual convention of the Traveling Engineers' Association has been postponed indefinitely. Just what action will be taken by the Master Car and Locomotive Painters' Association, which is scheduled to hold its annual meeting at Atlantic City, September 12-14, and the Chief Interchange Car Inspectors' and Car Foremen's Association, which is to meet in Indianapolis, Ind., October 3-5, will, of course, depend upon later developments. The present crisis may be regarded as one of the most serious periods in the progress of our railways, as well as in the history of the nation, and it will be necessary for every loyal railway officer and employee to do his utmost to bring it to a satisfactory conclusion.

## An Opportunity for Boosters

The *Railway Mechanical Engineer* has used its influence freely and fully toward the upbuilding and strengthening of railway mechanical department associations. It has done this with the knowledge that the members who attended the meetings of these organizations—and therefore the roads which they represent—would be greatly benefited thereby. Its editors could give remarkable instances of the increased efficiency and effectiveness of men who have been inspired and instructed by attending the conventions. In order to place on record convincing testimony as to the benefits derived from membership in different railway mechanical associations we want to secure data concerning specific instances of improvement. These testimonies or contributions should be brief, practical and to the point. Actual details of improvement or progress which have been made should be given as far as possible. The letters should not be more than 750 words in length and must be received at our office in the Woolworth building not later than November 1, 1916. Prizes of \$15 will be awarded for each of the three best articles; others will be paid for according to our regular rates. Here is a splendid opportunity to testify concerning the practical benefits which you have received from your association. It may encourage your higher officers to continue sending you to the meetings and may induce others to attend. If the higher officers generally realized the

possibilities of these meetings to the extent that some few do they would not only encourage their subordinates to attend, but would order them to do so and see that their expenses were paid.

## Clearance Diagrams for Passenger Cars

Most roads follow the practice of making clearance diagrams for locomotives; this practice can profitably be extended to the passenger train cars. On a certain railway a derailment occurred on one of the double track lines in a rather congested part of a city. The conditions were such that by throwing the outside track out, traffic could be continued. The buildings in the vicinity of this point were built so close to the track that a question arose as to whether there was sufficient clearance for the cars in the train that was about due. A reference to the clearance diagrams showed just what changes would be necessary to permit the train to pass with safety. This use of the diagrams not only avoided some delay, but also prevented any damage to the equipment. Another use to which such diagrams can be put is in determining upon what equipment can be sent out on foreign lines. This is of special importance at this time in connection with the movement of troops. The diagrams can be made in a concise form so as to be easily carried and referred to.

## Fuel Economy vs. Boiler Maintenance

Our fuel economy engineers are constantly advocating closing the fire door between each shovel full of coal fired, the reason for which is to prevent an undue amount of cold air entering the firebox, thus cooling the fire and—their second reason—cooling the firebox sheets and tube sheets, with the accompanying deleterious effects. We believe that the second reason should come first, for the effect of the cold air on the firebox sheets is far more expensive than the waste in fuel caused by cooling the fire. Maybe the fuel men think the same thing, but how many times do we see a fireman trying to prevent his engine from popping by opening this very same door to cool the fire? On the road, keeping the fire door closed is a hard and fast rule. If the engine pops the injectors are opened, and if the boiler is full the engine is allowed to pop, and no attempt is made to save the coal at a sacrifice of the tube and firebox sheets. This is one of the little things that the fuel engineer might easily overlook, and he needs only to confer with his confrere, the chief boiler inspector, to find out how important it is.

## Railroad Clubs Falling Down

It is unfortunate that a number of railroad clubs are falling down badly on the programs for their meetings. A strong, wide-awake subjects committee, which would plan the meetings for the entire year and would then use the various means at its disposal for securing the very best men to present the papers, and properly coach them, could do much to brace up these clubs and make them a real

force in the various districts in which they are located. Some idea of what can be accomplished by the display of a little real energy can be seen in the progress which was made by the Western Railway Club last year. It is unfortunate that the New York Railroad Club, with its wonderful facilities and strength in both membership and finances, should fall so far short of its opportunities. There is no reason why it should not be a real power in the railroad field because of the value and importance of the papers which might be presented before it and the discussions which could be provoked. Few railroad or technical associations have such a wealth of material available and such a good vehicle for bringing it out, and yet the greater number of its meetings are of a very mediocre type.

**Locomotive Boiler Efficiency**

In another part of this issue will be found the first installment of an article by J. T. Anthony dealing with locomotive boiler efficiency. The remaining part of the article will be published in an early issue. The author is well known in railway circles in this country and has given much study and investigation to matters pertaining to the improvement of the locomotive boiler. It is of particular interest to note the discussion of the effect of moisture in coal. There is a general idea that when coal is wet it burns better. Mr. Anthony takes direct issue with this assumption. Special attention is also called to the comments on tube heating surface, as well as the discussion of the length and diameter of tubes. While the present day locomotive is a remarkably efficient machine, there is still room for improvement. Firebox efficiency can be increased by using large grates, and providing longer combustion chambers and devices tending to mix the gases. The author points out that at present both grates and combustion chamber space are being forced beyond their capacity, while neither firebox nor tube heating surfaces are being used to their capacity. The diagrams will be found of great assistance in studying this article and the entire discussion should prove of the utmost value to railway mechanical department men. The article is in two installments, and the second one will be published in an early issue. The foregoing gives a few of the conclusions reached by the author, these being summarized in the conclusion.

**Hot Boxes on Freight Cars**

What causes hot boxes on freight cars? How may they be eliminated? Some claim that the greater proportion of hot boxes is caused by mechanical defects; others claim that carelessness and neglect on the part of the employees is responsible for most of the trouble. What are these mechanical defects and how may they be remedied? How can the employees be educated and inspired to perform their duties properly? It has been said that 90 per cent of all the oil in journal boxes is wasted. If this is so, how may it be conserved and used to the best advantage in the prevention of hot box troubles? These questions are merely suggestive of the different phases of the hot box question which we hope different contributors will discuss in the competition on Hot Boxes on Freight Cars which was announced in our August issue and which will close on October 1. We do not mean to infer that each contestant should discuss all of these phases of the question; rather is it our purpose to encourage each individual who has had experience in studying and helping to solve the problem to discuss that part with which he is most familiar and towards the solution of which he can advance the most practical suggestions. The best three letters, not to exceed 750 words in length and accompanied by such sketches or photographs as may be necessary, will be awarded prizes of \$15 each. Those contributions which are

not awarded a prize, but which are published, will be paid for at our regular rates. The judges will base their decision upon the practical value of the suggestions which are made. The contributions must be received at the offices of the *Railway Mechanical Engineer* in the Woolworth building, New York, not later than October 1.

**Passenger Car Windows**

When the men who conduct the joke columns in the daily papers run short of material they frequently fall back on the passenger car window and its tendency to stay shut at all times and under whatever treatment. It is therefore a relief to learn recently of a number of cases in modern car equipment in which the proceeding is entirely reversed. The locking apparatus in such cases is out of order and the windows positively refuse to stay shut, which condition makes matters interesting for the passengers, particularly when the train is passing through a rainstorm. But setting aside the daily papers' ideas of the car window, it is unfortunately true that a great many of them are a source of annoyance. It is an hourly occurrence on almost any railroad for passengers either to have difficulty in raising a window or to find that it is impossible to open one at all. A great many of the latching and lifting mechanisms are far from satisfactory, and some of the weather stripping seems to be designed with the sole purpose of supplying so much frictional resistance to the movement of the window as to make it impossible of opening with anything short of a jimmy. The condition mentioned above, of windows opening practically of their own accord, is not the usual one; but to anyone who travels to any great extent, windows which are difficult or impossible to open are nothing new. There is a great deal of justification in the complaints of the traveling public regarding window conditions in the average passenger equipment, and there is room for much improvement in the application of fastenings and weather stripping to make the windows so that they can be easily opened by passengers and so that they will at the same time remain storm proof when closed.

**The Successful Officer**

As a foreman or officer how do you approach your work? You may have few or many men under you. To produce results you must work through them. They may be of many different types and minds, but you, by your personality, have got to inspire and educate them to direct their energies to the best possible advantage. Too many supervising officers take a narrow and superficial view of their responsibilities and possibilities. They tie themselves up with so much detail and take so intense an interest in their own detail performance that they lose the broad aspect which is so necessary in supervising the work of others. They lose sight of the future because their noses are kept at the grindstone of the present. They will spend time and energy on some problem which will give an immediate return that may be measured in dollars and cents and never see the big thing, the neglect of which may cost their employers hundreds of thousands of dollars a few years hence. True, the managements often wink at this practice because they are more interested in making an immediate showing than of taking the chances of sowing where others may reap in the future. It is this shortsighted attitude that is responsible for the neglect and lack of interest in the apprentice problem and the development of means for properly selecting and developing men. It is this lack of foresight which has placed the emphasis on the conservation and efficient use of materials and at the same time has almost overlooked the human element, the proper handling of which can save dol-

lars, whereas the better use of materials may only save cents, or even mills.

#### An Important Car Department Convention

The Master Car Builders' and the American Railway Master Mechanics' Associations consider and pass upon the larger and more important problems of the mechanical department. A considerable number of minor mechanical department associations discuss the detail problems with which they are concerned; the time is surely coming when these organizations will be more closely allied with the larger ones, thus greatly improving their effectiveness and possibilities. Most of these minor associations, with one exception, are largely concerned with the work of the locomotive department and touch only to a slight extent and largely incidentally on car department problems. The exception is the Chief Interchange Car Inspectors' and Car Foremen's Association, which, although it has been growing rapidly in strength in recent years, has not as yet achieved a place to which its work rightly entitles it. Its leaders, however, realize that because of the fact that its members are on the firing line and are intimately acquainted with all the details of the work handled by the car department it can become a most important adjunct to the Master Car Builders' Association. With this in mind they have arranged to broaden its activities by interesting more of the members of the car department and at the same time concentrating upon the solution of the larger and more troublesome questions which confront them. That they are on the highway to success in their efforts is indicated by the program for the annual meeting which is to be held next month at Indianapolis, Ind.

Of special interest is the unique competition on car department apprenticeship. Considering the efforts which have been made to develop an effective car department apprentice system on several roads, and the fact that the members of this association are practical men, thoroughly acquainted with the detail conditions under which the work of the car department is carried on, it would seem that the individual members of the association would be in position to make some splendid suggestions looking toward more rational methods for recruiting its ranks, and that these suggestions, after thorough study and discussion, could be formulated and referred to the Master Car Builders' Association as recommended practice. While the members of the Master Car Builders' Association have discussed this question a number of times they have never gotten very far with it. While they realize its tremendous importance in connection with the future welfare of the car department, their lack of success in solving the problem furnishes the Chief Interchange Car Inspectors' and Car Foremen's Association a splendid opportunity to make itself of real value and effectiveness to the larger association.

The same thing is true of the other subjects which are to be reported upon and it is hoped that the discussions will be freely participated in by those present. In the discussions which have been held in our columns during the past year in relation to the qualifications and training of car inspectors the fact was clearly developed a number of times that the effectiveness of the car department can be greatly increased by encouragement on the part of supervising officers of those men who occupy important, though minor, positions in the department. It is anticipated that the constitution and by-laws of the Chief Interchange Car Inspectors' and Car Foremen's Association will be amended in order to admit to its membership car inspectors, M. C. B. bill clerks and others actively engaged in the work of the car department. One way of encouraging these men would be to select a number of them who are best fitted to take advantage of it and send them to the convention. Undoubtedly the concrete returns which would be apparent within a reasonable time would many times repay the expense thus incurred.

#### NEW BOOKS

*Oil Fuel Equipment for Locomotives.* By Alfred H. Gibbins. Bound in cloth, 120 pages, 5½ in. by 8½ in. Illustrated and indexed. Published by the D. Van Nostrand Company, 25 Park Place, New York, N. Y. Price \$2.50.

This book is of a practical nature, including only such references to theory and the principles of combustion as are considered necessary in order that the subject may be clearly understood. It is intended chiefly for the use of mechanical department officers, but contains a great deal of data of use to anyone having to do with oil-burning locomotives. It deals with the different systems of burning fuel oil, the regulation of draft and of oil supply and the arrangement of the various parts of the apparatus. A chapter is devoted to tests and running conditions and one to auxiliary appliances, while there is included for reference a list of modern publications and papers on fuel oil. The illustrations are particularly clear, most of them being line engravings, although some very good half-tones are included and are of very considerable assistance in making the subject clear. There is also an inset which shows the general arrangement of the apparatus for the pressure-jet system of oil burning.

*The Principles and Practice of Cost Accounting.* By Frederick H. Baugh. Bound in cloth, 180 pages, 6 in. by 8½ in. Published by the author. P. O. Box 682, Baltimore, Md. Price, \$3.

The author's object in the preparation of this work was to provide a comprehensive and practical presentation of the general principles upon which is based the cost accounting for manufactured articles, the application of these principles in a general manner and the illustration of the details. The objections raised by many manufacturers to the installation of a system of cost accounting have been due often to the number and complexity of the books and forms proposed and to the extra labor necessary to keep them. The author's methods call for little, if any, addition to the books which a corporation ordinarily should possess, and in this respect his work should be worthy of careful attention. The treatment of the subject is based on the assumption that the reader has an elementary knowledge of ordinary accounting and is viewed from the standpoint of the accountant rather than that of the factory manager. It does not deal with factory management, or efficiency engineering so called, except in so far as cost accounting is necessary for the purpose of efficient administration.

*Power Transmission by Leather Belting.* By Robert Thurston Kent, M.E., Consulting Engineer. Bound in cloth, 114 pages, 5½ in. by 8 in. Illustrated. Published by John Wiley & Sons, Inc., New York. Price, \$1.25 net.

This book is one of a new Wiley engineering series, in which each book will be devoted to a single subject of engineering practice, the object being to place in the hands of the practicing engineer the essential information regarding each subject. They are intended to be more in the nature of a manual of practice than theoretical discussions of the subject treated. The work of the author in the present volume has been largely that of a compiler of the work of Taylor, Barth and others gathered from the literature of the subject, which has been widely scattered through the transactions of engineering societies and the files of technical journals. Two of the eight chapters of the book are devoted to a discussion of the theory underlying belting practice. The remainder of the book is of direct practical application to the man in the shop who has to do with the operation of the belts or to the engineer dealing with the layout of belt drives. The practical value of the book is considerably increased by the inclusion of a number of tables at the back of the book which are arranged with thumb index for convenient access. This is a feature which will be greatly appreciated by all users of the book.

## COMMUNICATIONS

### COMBINED AUTOMATIC AND STRAIGHT AIR ON FRENCH PASSENGER EQUIPMENT

PARIS, France.

TO THE EDITOR:

The Paris, Lyons, Mediterranean Railway makes use of a system of combined automatic and straight air brakes on its passenger equipment which operates in a manner similar to the combined automatic and straight air brakes now in use on many American locomotives. A so-called double valve is connected up under each coach as shown in the sketch, two train pipes, of course, being necessary, one for the straight air and one for the automatic brake. The straight air is used in holding trains on long descending grades.

The operation is as follows: When the automatic brake is applied the piston moves to the right, opening communica-

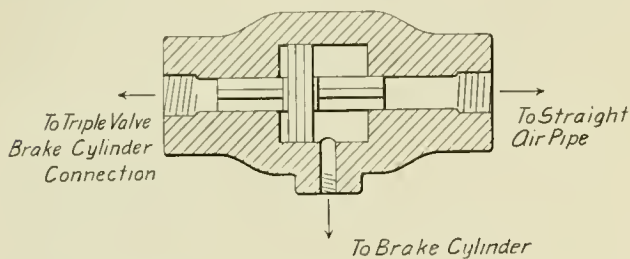

Type of Three Way Valve Used in French Passenger Brake Equipment

tion between the triple valve and the brake cylinder. The brake is applied and released in the usual way. When the straight air is applied the piston moves to the left, thereby connecting the brake cylinder with the straight air train line, the valve remaining in this position until the next automatic application is made. In the case of a break-in-two, the automatic brake is not prevented from applying in the usual way.

The straight air is controlled by a wheel-operated feed valve. When screwed down tight the valve is closed, but by unscrewing it the valve is permitted to open against the tension of a spring which determines the straight air pipe pressure, the tension of the spring being decreased as the hand wheel is unscrewed.

W. G. LANDON.

### THE "I. C. C. DETECTOR"

CHICAGO, Ill.

(With apologies to Wallace Irwin.)

DEAR EDITOR:

Like Hon. T. R. I have make successful come-back. Previous to position of I. C. C. detector, I have job at Lakeside shop of Western Mo. R. R. and polish tender with lampblack and oil to make brilliant for 18 hr. Royal Blue Streak.

I alight Lakeside today with new clothes and iron cross prominently display on bosom. Immediately I spy previous boss flutter around ash-pit, so I strut by with right thumb in vest corner. "Ohio," I emit for greeting. He reply with grunt, "Hello, ginney, are you still wiping tanks?" I answer with silence and blushing flip engraved card in paw. "Ordinary hat pretty tight now, eh?" I grin with fine nature and dispense business.

I see old No. 23 approach and relate how I receive once hot water down neck when removing cinder from pit by leak in cylinder casting. On approach, I are astonish to see when steam apply same leak exist and cloud of steam flow between saddle. I announce repairs have to make and old boss reply it are impossible without renewing cylinder. I express regret with tremor in throat, but he quiet which make issue of form 5 less heartrending.

We examine five more locomotives and I are compel to form 5, four of them for following defect:

Engine No. 18 have 1 9/16 in. flange, which are dangerous on account cutting bolts on track use by flier and endanger innocent widows and orphans.

Engine No. 24 are remove from service on account cylinder valve leaking and shooting steam in right engineer window. Also it have 1/4 in. lost distance between tender and 9/64 in. flat spot on couple pin.

Engine No. 26 have crack bell and won't sound by air unless assistant engineer start with rope.

Engine No. 19 do not prime water unless 3 feet in tank, which are leaking bad, headlight glass missing and can't see 1000 yards on account rusty reflector; also couple bar have hole wore oblique. Cab also need paint bad and cushions have lose most stuffing.

Engine No. 22 only one pass and she about ready for scrap, but on account old friendship, I wink at some defect and recite that it are account personal love for old boss that I relent.

I express great sorrow, but hope for 100 per cent efficiency next time while he remark in blank verse, which I unable to repeat on account censor by postmaster-general.

Yours truly,

TOBESURA WENO.

### THE M. C. B. BOOK OF RULES

LUDLOW, Kv.

TO THE EDITOR:

I was much interested in the editorial in the *Daily Railway Age Gazette* of June 15, 1916, entitled "Suggestions Regarding M. C. B. Rules." Such a book, composed of the M. C. B. Rules of Interchange, the Loading Rules, the Tank Car Rules and the Safety Appliance Rules, which are required by the car inspector on the job, would assist him in forming quicker and better judgment regarding defects of cars, and would tend toward uniformity of judgment by all inspectors. It would give the inspectors more time, so that they could watch more carefully things that now have to be passed over hurriedly, and would reduce considerably the amount of writing which car inspectors have to do now.

M. GLENN, SR.

**BELGIAN COAL.**—The output of coal in Belgium in 1903 was 23,871,000 tons; in 1913 the output had declined to 22,858,000 tons. The production has been practically stationary for the past 20 years. While Belgian coal mining has thus made little or no progress of late, the output of coal in the United States increased between 1903 and 1913 to the extent of 60 per cent; that of Great Britain, 23 per cent; that of Germany, 18 per cent, and that of France, 15 per cent. As the production of pig-iron from Belgian blast furnaces was increasing before the war, it was necessary to import more coal from Germany. Of course, the war has utterly disorganized Belgian metallurgy, coal mining, coal importing and other industries.—*Engineering*.

**DIFFERENCE IN TEMPERATURE CAUSES LOSS OF HEAT.**—Loss of heat by radiation varies with the difference in temperature between the steam and the surrounding medium, the insulating quality or low conductivity, of the covering and the amount of the exposed area. Variations in detail in different plants vary the monetary loss by radiation, but some idea of the magnitude of this loss in one plant may be gained from the statement that by the proper insulation of a pipe having an area of 65 sq. ft., carrying steam at 150 lb. pressure, with a room temperature of 65 degs. F., the condensation has been reduced from 74.40 to 11.58 lbs. per hour. With coal at \$4 per ton and with an evaporation of 11 lb. of water per pound of coal, this would be equal to a saving of about 50c. per year for each square foot of pipe.—*Power*.

# LOCOMOTIVE BOILER EFFICIENCY

Not Governed by Mere Extent of Heating Surface; Firebox Offers Largest Field for Improvement

BY J. T. ANTHONY\*

I

THE sustained hauling capacity of a locomotive depending primarily upon the ability of the boiler to furnish steam, it has been necessary to constantly increase the capacity of the boiler in order to keep pace with the increase in size and power of the locomotive. This has been accomplished mainly by increasing the size of the boiler, not by increasing its efficiency.

The increase in capacity of the locomotive has been accompanied by an increase in over-all efficiency. The fuel consumption per ton-mile has decreased. The steam consumption per indicated or drawbar horsepower has been greatly reduced, and so has the coal consumption; but the steam generated per pound of fuel (which is the measure of boiler efficiency) has increased only as the brick arch and similar devices have been added to the boiler. There has been little or no increase in boiler efficiency due to changes in boiler design,

There seems to be some confusion in regard to the function of the superheater, and the economies effected by it are often wrongly credited to the boiler. Primarily, it is the function of the locomotive boiler, with its self-contained furnace, to liberate the heat in the coal, absorb this heat and convert water into steam at the desired pressure. The over-all efficiency of the boiler is measured by the ratio of the heat absorbed to the heat contained in the coal as fired.

It is not the function of the superheater to evaporate water, but to increase the temperature of the steam formed in the boiler, thereby increasing its heat energy and volume per unit of weight, and making it capable of doing more work in the cylinder. The superheater absorbs a part of the heat liberated in the firebox, and this heat must be taken into account in arriving at the boiler efficiency; but the heat so absorbed increases the thermal efficiency of the engine, and does

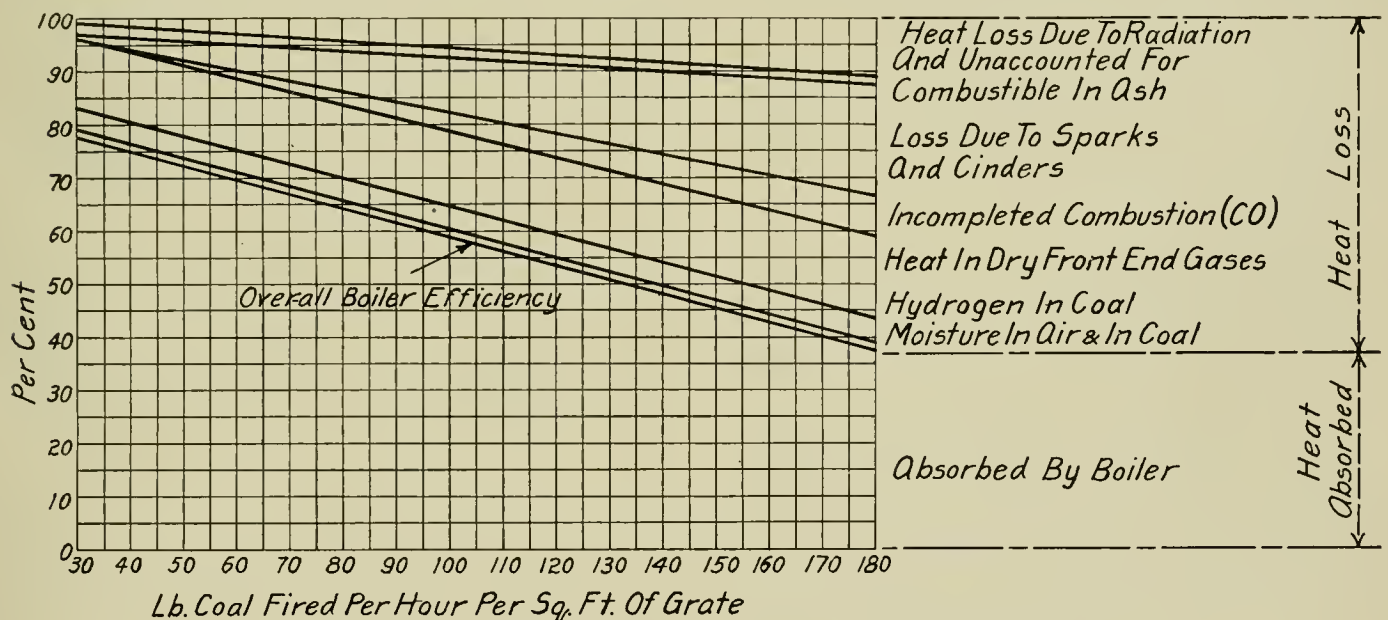

Fig. 1.—Heat Loss and Boiler Efficiency as Affected by Rate of Combustion

except in a comparatively few cases where combustion chambers have been used.

The brick arch, while by no means a new device, has come into very general use during the past five years. There are now more than 30,000 locomotives equipped with it. No change has been made in the general firebox design to accommodate the arch, although the use of the trailer truck type of engine, with its deep firebox, has greatly facilitated the arch application because of the greater firing clearance provided at the throat sheet. However, the recognized economies resulting from the arch must be ascribed to the arch, and not to any improvement in boiler design.

The wide and constantly increasing use of the fire tube superheater (more than 18,000 are now in service in this country) has effected such a marked decrease in fuel and water consumption and increase in locomotive efficiency, as to partially blind us to the defects of the locomotive boiler.

\* Assistant to president, American Arch Company, 30 Church Street, New York.

not directly increase the evaporative efficiency of the boiler.

The addition of the brick arch has increased boiler efficiency; the addition of the superheater has resulted in a large increase in engine efficiency, and the two devices, used in conjunction with the mechanical stoker, have played a most important part in the development of the high capacity locomotive of the present; but there yet remains the difficult task of designing a locomotive boiler that will meet the combined requirements of high capacity, high efficiency, simplicity of construction and low maintenance cost—certainly a large order.

## BOILER FUNCTIONS

In order to make an intelligent study of boiler efficiency and requirements, it is necessary that we consider separately the functions of the firebox, or furnace, and the heating surfaces; make an analysis of the heat losses and, if possible, determine the causes.

It is the duty of the firebox (or furnace) to liberate the

heat contained in the coal; and the efficiency with which it performs this duty is measured by the ratio of heat liberated to heat contained in the coal.

The duty of the heating surface is to absorb the heat liberated in the furnace, and its efficiency is measured by the ratio of heat absorbed to heat liberated in the furnace. However, this is not the true heating surface efficiency, as a part of the heat liberated in the furnace is not available for absorption by the heating surface, and should not be charged against it; the true heating surface efficiency is the ratio of heat absorbed to heat available for absorption.

The combined efficiency of the furnace and heating surface (or the over-all efficiency of the boiler) is the ratio of heat absorbed to heat contained in the coal, although this is not the true over-all efficiency. Part of the heat loss is unavoidable, and should not be charged against the boiler.

#### HEAT LOSSES

The heat balance chart, Fig. 1, shows the average heat losses at varying rates of combustion on four typical boilers, such as are used on modern locomotives. While results of individual tests vary widely, as might be expected, the general trend of the heat losses is shown by the platted lines. All boilers were equipped with Security sectional arches and fire tube superheaters that were representative of present-day practice. The coal used was high volatile bituminous, containing about 35 per cent volatile matter, with a heat value of 14,000 heat units (B. t. u.) per pound, which is above the average grade of coal used in locomotive service.

A casual inspection of the chart, Fig. 1, reveals the fact that the boiler efficiency depends largely upon the amount of coal fired per square foot of grate. As the rate of combustion increases, the heat losses increase and boiler efficiency drops. The heat losses are due to:

1. Moisture in air and coal,
2. Hydrogen in coal,
3. Heat in dry front end gases,
4. Incomplete combustion,
5. Sparks and cinders,
6. Unburned coal lost through grates, and
7. Radiation from boiler and other losses unaccounted for.

#### MOISTURE IN AIR AND COAL

Moisture contained in the air used in burning the coal is flashed into steam in the firebox, highly superheated, and passes through the fire tubes along with the other gases, giving off part of its heat; but escaping from the stack still in the form of superheated steam, at the temperature of the front end gases. With the air entering the firebox at a temperature of 65 deg. F. and front end gases at a temperature of 600 deg. F., every pound of moisture passing out as superheated steam carries with it about 1,300 heat units. The heat loss due to this source does not normally amount to much, but under adverse conditions will reach 1½ or 2 per cent of the total heat contained in the coal.

Moisture in coal contributes to the heat losses in the same manner as moisture in air. With a coal containing only one per cent moisture, the loss under the above temperature conditions would be 13 heat units per pound of coal burned, or less than one-tenth of one per cent; but with a Western coal containing 12 to 15 per cent moisture, the loss will amount to 1½ per cent or more.

The practice of wetting down the coal on the tender is a very general one. While it contributes to the comfort of the engine crew and, under some conditions, results in a reduction of smoke and small fuel saving, the fact remains that every pound of water put into the firebox escapes at the stack as superheated steam that contains an appreciable amount of heat. The presence of a large amount of slack and dust in the coal offers the only excuse for this practice; and, with a properly designed firebox, this excuse would be largely removed.

There seems to be a prevailing idea that water in some mysterious way aids combustion—that under the influence of the high firebox temperature, it breaks down into hydrogen and oxygen; and because the former is intensely combustible and has a very high heat value, and the latter is the supporter of combustion, the result is an increase in heat generation. Needless to say, the idea is erroneous.

We have no proof that the water does break down into hydrogen and oxygen, under the influence of firebox temperatures alone. If it did, the heat absorbed by the breaking-down process would equal the heat liberated when the hydrogen was re-burned, and the net result would be, not a gain, but a loss, as the water formed in re-burning the hydrogen would escape in the form of superheated steam, as explained above.

#### HYDROGEN IN COAL

It is sometimes difficult for the layman to understand why the hydrogen contained in coal should contribute to the heat loss, and particularly so in view of its very high heat value. The reason, as stated before, is that hydrogen forms water when burned; and the water escaping at the stack in the form of highly superheated steam carries away and wastes the heat contained in it.

That this heat loss is high, is due to the large amount of water formed when hydrogen burns. One pound of hydrogen requires eight pounds of oxygen for complete combustion, which results in the formation of nine pounds of water. When we burn a pound of coal that contains 5 per cent hydrogen, .45 of a pound of water is formed. If this passes out the front end at a temperature of 600 deg. F., the heat loss amounts to 575 heat units, or about 4 per cent of the total heat contained in the coal. In general, the extent of this loss depends upon the percentage of hydrogen in the coal and the temperature of the front end gases.

#### HEAT IN DRY FRONT END GASES

The loss due to this source is almost constant, throughout the range of firing. At low rates of combustion, light fires are carried. The air supply per pound of coal is large, and the front end temperatures are relatively low. As the rate of combustion increases and the thickness of the fire increases, resistance to the passage of air through the fuel bed increases, and the amount of air supply per pound of coal decreases.

At the same time, however, the front end temperature is increased; so that in general we may say that for any one boiler this heat loss is almost constant, the increase in front end temperatures being offset by the decrease in the air supply per pound of coal burned, as the rate of combustion increases. This loss averages about 15 per cent of the total heat contained in the coal; but, as will be shown later, a large part of this loss is unavoidable, and cannot be properly charged against the boiler.

#### INCOMPLETE COMBUSTION—CARBON MONOXIDE

The heat losses due to incomplete combustion and the formation of carbon monoxide vary widely. On the tests under consideration, the losses averaged from zero at the lowest rate to 7½ per cent at the highest rate—although there were, in individual cases, heat losses of as much as 20 per cent due to incomplete combustion.

With uniform firing methods, the heat losses due to incomplete combustion for any one boiler will increase as the rate of combustion increases. Since this increase is always accompanied by decrease in air supply, incomplete mixing of the gases, or improper firing, this heat loss is unnecessary and can be eliminated by proper design of furnace and proper methods of firing.

#### LOSSES DUE TO SPARKS AND CINDERS

As shown on the chart, Fig. 1, heat losses due to sparks and cinders increase rapidly as the amount of coal fired

increases, the average losses varying from 1 per cent at low rates to 20 per cent at high rates. Individual tests will show higher losses under the same conditions, but this is a fair average. As the rate of combustion increases, the draft increases; and the increase in velocity of the air rushing through the fuel bed results in a constantly increasing percentage of the fine particles of coal being picked up and carried off unconsumed.

It is also evident that the losses due to sparks will be affected by the nature of the coal—that is, upon the amount of slack and fine particles contained in the coal—and also upon the method of firing. With an overfeed stoker, using a large amount of slack and screenings, the spark and cinder losses will be much higher than when firing with lump coal. In the former case, a large part of the fine coal is shot in above the fire and never reaches the fuel bed; but is caught by the draft and whirled into the tubes, unburned.

#### COMBUSTIBLE IN ASH

The heat loss due to this source is relatively small, and depends primarily upon the physical condition of the coal as to its size, and the size of the air openings provided in the grates. There is a slight decrease in this heat loss, as the rate of combustion increases—this being due to the increased draft offering more resistance to any particles of coal or ash falling through the grates into the ashpan.

#### RADIATION AND UNACCOUNTED FOR

Heat loss due to radiation from boiler surfaces is, under normal conditions, quite small, and should not vary with increase in rate of combustion, as the amount of heat radiated depends primarily upon the temperature of the radiating surfaces. In the case of the boiler shell this is practically constant. The temperature of the atmosphere would of course affect the heat loss; but under the most adverse conditions, radiation losses from a well-lagged boiler are of minor importance.

The radiation from the fuel bed to the ashpan is difficult to determine; but probably is not very large both on account of the interference of the grates and the inrush of cold air through the grates taking up much of the heat imparted to them.

The "unaccounted for" losses are due, in part, to the escape of unburned hydrocarbon gases (which are not revealed by the ordinary gas analysis) and in part to errors which fail to account for all of the other losses.

#### FURNACE EFFICIENCY

Disregarding the small loss due to radiation, we may safely assume that the losses unaccounted for, losses due to combustible in ash, to sparks and cinders, and to incomplete combustion, are all directly chargeable to the firebox, or furnace. That is, the sum of these losses represents the heat contained in the coal that is not liberated in the firebox, and is, therefore, not available for absorption or steam generation.

In Fig. 2, curve No. 1 represents the furnace efficiency. The space above this line represents the sum of the heat losses enumerated above, throughout the range of tests, being heat contained in the coal that is not liberated by the furnace. The total space below curve No. 1 represents the heat liberated by the furnace, and the ratio of heat liberated by the furnace to heat contained in the coal (as shown on the right) gives the true furnace efficiency.

At low rates of combustion (30 lb.), a furnace efficiency as high as 96 per cent is obtainable; that is, 96 per cent of all the heat contained in the coal is liberated in the firebox. As the rate of firing increases, the percentage of heat liberated decreases. At the rate of 180 lb. of coal per square foot of grate per hour, we get a furnace efficiency of less than 60 per cent; or, more than 40 per cent of the total heat contained

in the coal is not liberated in the firebox, and is not available for steam generation.

#### UNAVAILABLE HEAT

In Fig. 2, curve No. 3 represents the over-all boiler efficiency; or, the space below this line represents the percentage of heat absorbed by the boiler at varying rates of combustion. The space below curve No. 1, under Furnace Efficiency, represents the heat liberated by the furnace at varying rates of combustion; so the difference between these two efficiency lines (or the space between curve No. 1 and curve No. 3) represents the percentages of heat liberated by the furnace and not absorbed by the boiler, at varying rates of combustion. This is the sum of the heat losses in dry front end gases, hydrogen in coal, and moisture in air and coal as shown on the chart, Fig. 1.

It is apparent that there is but a slight increase in the percentage of heat liberated and unabsorbed, as the rate of combustion increases; and that the drop in over-all boiler efficiency is due almost entirely to the inability of the furnace to burn coal efficiently, particularly at high rates of combustion.

The heat loss represented by the space between curves 1 and 3 is largely unavoidable, and can be charged only in part to inefficient heating surfaces. In order to make heat flow from one body to another, it is necessary to have a difference in temperature. When the two bodies have the same temperature, heat transfer from one to the other ceases. The same principle applies to heat transfer in the locomotive boiler. With a gage pressure of 200 lb., the temperature of steam and water in the boiler is 388 deg. F.; and it is impossible to reduce the temperature of the gas passing through the tubes below this point. If we could make the tubes infinitely long, or permit the gases to remain in them for an infinite length of time, the final temperature of the gases would be the same as that of the steam in the boiler, or 388 deg. F.

It is therefore evident that the heat required to raise the temperature of the gases from the temperature of the atmosphere to the temperature of the steam in the boiler, is unavailable for absorption and cannot rightly be charged against the boiler heating surfaces.

With an atmospheric temperature of 60 deg. and a front end temperature of 600 deg., 60 per cent of the heat contained in the dry gases is unavailable for absorption.

Similarly, the heat carried away in the superheated steam, formed by burning the hydrogen in the coal and evaporating the moisture in the air and coal, contributes to the unavoidable heat loss. A larger percentage of the heat contained in the superheated steam is unavailable, than is the case with the dry gases, due to the large amount of heat absorbed in evaporating the water into steam, the latent heat or evaporation being 970.4 heat units.

Steam escaping at the stack at a temperature of 600 deg. represents a heat loss of about 1,300 heat units per pound; but of this amount 1,200 have been consumed in evaporating the water and raising the temperature to that of the boiler, or 388 deg., leaving approximately 100 heat units (or 8 per cent of the heat contained in the front end steam) available for absorption.

The curves in Fig. 3 show the average front end temperatures, pounds of air used per pound of coal (computed from front end gas analysis) and firebox temperature, covering the tests under consideration.

Using the front end temperature shown at the various rates of combustion, and combining the unavailable heat contained in steam and dry front end gases, we find that curve No. 2 (Fig. 2) represents the amount of heat available for absorption at varying rates of combustion. The space between curves 1 and 2, then, represents the total *unavailable* heat escaping at the front end; and the space between curves 2 and

3 represents the total *available heat that is rejected* by the boiler heating surfaces and escapes at the front end.

HEATING SURFACE EFFICIENCY

The true heating surface efficiency is the ratio of heat absorbed by the boiler (represented by the space below curve No. 3) to heat available for absorption (represented by the space below curve No. 2). These ratios are plotted at the various rates of combustion and shown at the top of the chart by the dotted line. This indicates that the locomotive boiler heating surfaces absorb from 96 to 84 per cent of the *available* heat.

A comparison of the curves representing the true heating surface efficiency and furnace efficiency is enough to warrant the broad statement that the inefficiency of our modern loco-

the heat that is *rejected* by the boiler heating surfaces and is chargeable to them. The shaded portion of *E* represents the heat that is *unavailable* for absorption, and that cannot be properly charged against the boiler heating surface in considering its efficiency.

FURNACE LOSSES

Diagrams *C* and *D* show heat losses that are directly chargeable to the design of the locomotive firebox and boiler. Both of these losses are preventable in large part, but it is very evident that the furnace (or firebox) presents a much wider field for improvement in design and efficiency than do the boiler heating surfaces.

The principal furnace losses are those due to sparks and cinders; incomplete combustion, allowing the formation of

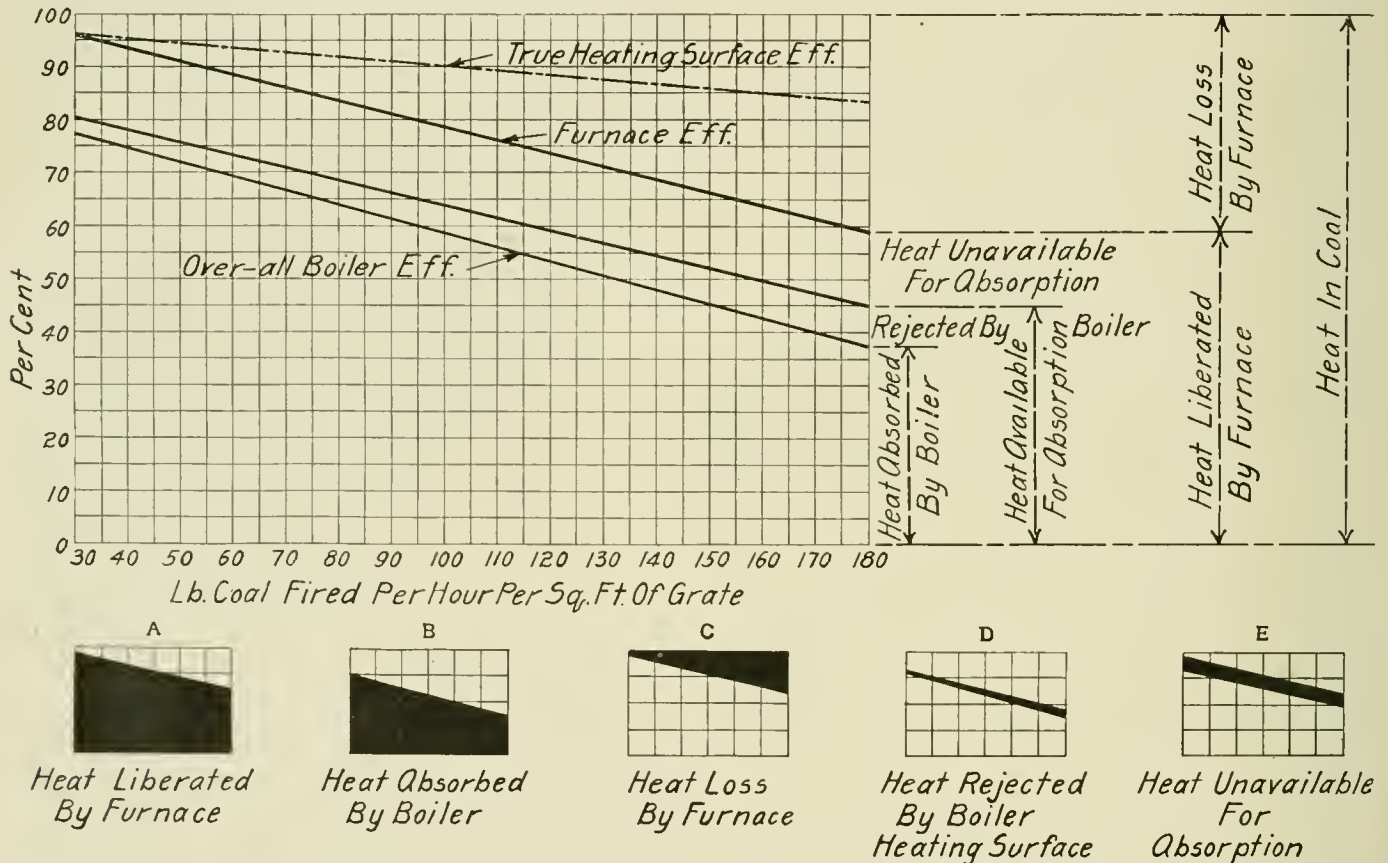

Fig. 2—Diagram Showing Heat Distribution in a Locomotive Boiler

motive boiler is due largely to the inability of the present design of firebox to liberate the heat or properly burn the coal that is fired.

HEAT DISTRIBUTION

The small diagrams (*A, B, C, etc., Fig. 2*) will perhaps show more clearly the distribution of heat and heat losses referred to heretofore. The height of a rectangle represents the 100 per cent of heat contained in the coal; and the base represents the pounds of coal fired per hour per square foot of grate, as shown in the large chart of Fig. 2. The total heat in the coal fired throughout the range of tests being represented by the area of the rectangle, the shaded portion of *A* represents that portion of the heat liberated by the furnace, as the rate of combustion increases from 30 to 180 lb. The shaded portion of *B* indicates the amount of heat absorbed by the boiler under the same conditions. The shaded portion of *C* represents the amount of heat lost by the furnace; or, more correctly, the amount of heat contained in the coal that is not liberated by the furnace, but is chargeable to the furnace. The shaded portion of *D* represents that portion of

carbon monoxide, and the escape of unburned hydrocarbon gases. Of these, the loss due to sparks and cinders is the most serious.

As shown in Fig. 1, these losses increase rapidly as the rate of firing increases. In order to burn more coal on any one grate, it is necessary to increase the draft. This increase in draft—or drop in pressure—results in an increase in the velocity of flow of air through the fuel bed, and the flow of gases into the tubes.

In order to approximate complete combustion in a locomotive firebox at moderate or low rates of firing, it is necessary to have an air supply of 15 or 16 lb. per pound of coal. At atmospheric temperature, this means that we must furnish approximately 200 cu. ft. of air for every pound of coal burned. At the low rate of 60 lb. of coal per square foot of grate per hour, a locomotive with 70 sq. ft. of grate area will require 14,000 cu. ft. of air per minute. With an air opening through the grates of 30 per cent—which is higher than the average practice today—the velocity of the air going through the grates would be about 700 ft. per minute, or over 11 ft. per second.



The total air openings through the fuel bed will of course depend on the nature of the coal and the thickness of the fuel bed, principally the latter, as experiments show that the resistance to the flow of air through the fuel bed varies directly as the thickness of the fuel bed. While it is impossible to even approximate the amount of air opening through a fuel bed of any thickness, it is safe to assume that this is a good deal less than the air opening through the grates, and the gases will pass through and leave the fuel bed at a much higher velocity than that at which the air leaves the grates.

Assuming the gases to leave the fuel bed at a temperature of 2,200 deg., the volume would be increased to approximately 75,000 cu. ft. of gas per minute, and the velocity would probably approach 7,500 ft. per minute, or 125 ft. per second, which is equivalent to 85 miles per hour. It is not difficult to imagine the action of such a hurricane on the fine particles of coal; though, under the conditions named, the loss due to cinders would amount only to about 5 per cent. As the rate of combustion increases, the velocity of the gases leaving the fuel bed and entering the tubes also increases. These velocities range, in ordinary locomotive practice, from 100 to 300 ft. per second, or as high as 200 miles per hour.

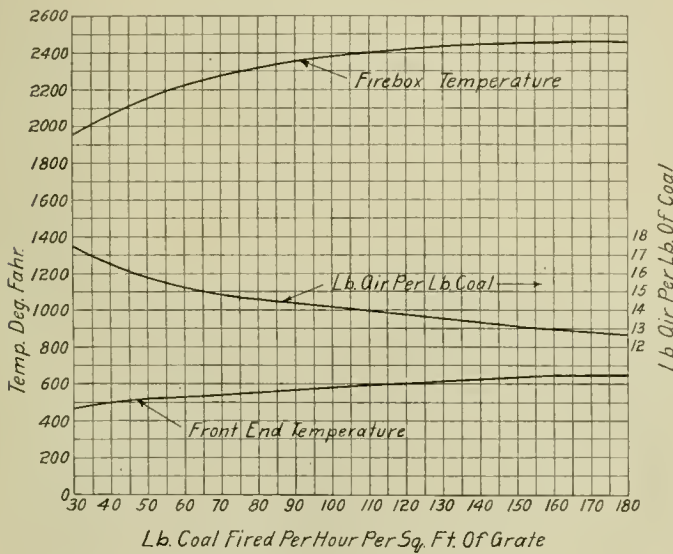

Fig. 3—Air Supply and Temperatures

It might appear that with such velocities it would be impossible to hold the fine particles of coal in the firebox long enough to burn them; but the successful application of pulverized coal-burning apparatus to locomotive type boilers and the approximately perfect combustion obtained prove conclusively that fine coal can be burned completely in a locomotive firebox. The fineness of the coal and the method of firing are important factors in burning pulverized coal, but the same general principles are applicable to the burning of lump coal containing a large amount of slack.

In order to do this successfully, it is necessary to make the following provisions:

- 1.—Large grate area, in order that a light, level fire may be carried, thereby insuring an ample and uniform flow of air through all parts of the fuel bed.
- 2.—Refractory baffles and mixing devices that will tend to hold the fine particles down until they are ignited, and to thoroughly mix those particles carried in suspension with the oxygen present.
- 3.—Combustion chambers of ample volume and length, thereby reducing the velocity of flow of the gases, and giving the solid particles of coal carried in suspension more time to burn.

The furnace losses due to incomplete combustion, or the formation of carbon monoxide—and in many cases the es-

cape of hydrocarbon gases totally unburned—can be eliminated or greatly reduced by the provisions mentioned above.

These losses are due principally, if not entirely, to the lack of sufficient air or oxygen; to imperfect mixing of combustible gases with the oxygen that may be available, and to the lack of sufficient combustion chamber space. A large portion of bituminous coal burns as a gas, and in order to burn it successfully, it is necessary to make the above provisions.

It is impossible to lay down any fixed rules governing these requirements. The amount of excess air needed to complete combustion will depend upon the efficiency of the mixing devices, upon the length and volume of the combustion chamber and upon the amount of volatile combustible in the coal and the amount of coal being burned. The length and volume of the combustion chamber will in turn depend upon the amount of volatile to be burned, the amount of oxygen available for combustion and the efficiency of the gas-mixing devices.

Front end gas analyses usually show a surplus of oxygen in the presence of carbon monoxide, thereby indicating that the incomplete combustion is not due to lack of oxygen, but to inefficient mixing of the combustible gases with the oxygen present. As the thoroughness of the mixing increases, the excess supply of oxygen can be decreased, other factors remaining the same. The length and volume of combustion chamber space also plays an important part in promoting complete combustion. Any increase in combustion chamber space means additional time for the mixing and burning of the volatile combustibles; but the effectiveness of the combustion chamber can be best promoted by increasing the length rather than the cross sectional area.

When burning 60 lb. of coal per square foot of grate per hour in a firebox with 70 sq. ft. of grate and a volume of 300 cu. ft., the products of combustion arising from the fuel bed have a volume sufficient to fill the firebox completely, four times per second. This means that the average time available for the burning of each particle of gas or coal-dust is only one-fourth of a second. Combustion is a series of explosions, and progresses with almost incredible velocity, hence this one-fourth of a second might be ample, if the temperatures were sufficiently high to insure instant ignition, and the air supply sufficient to insure every particle of combustible coming into immediate contact with the requisite amount of oxygen.

However, in order to insure this last, it is necessary to have an excess of oxygen present. As the rate of firing increases, the amount of volatile combustible and coal-dust also increases, almost in direct proportion; while the air supply per pound of coal decreases, owing to the increase in thickness of the fuel bed and the resistance it offers. At the same time there is an increase in the temperature of the firebox, which gives an increase to the volume of gases, in addition to that due to the burning of more coal.

By increasing the rate of firing from 60 to 120 lb. of coal per square foot of grate per hour, we practically double the volume of the gases discharged from the firebox, or we cut the time available for combustion in half. In other words, the gases fill the firebox eight times per second; and the time available for combustion is one-eighth of a second, while the supply of oxygen is reduced by the decrease in air supply. Under these conditions, in order to insure approximately perfect combustion, the mixing of the gases would have to be more effective than in the former case; and combustion chamber space would have to be increased proportionately.

It was stated that combustion is a series of explosions that takes place with great velocity. This is true when combustion begins; but as it proceeds it becomes slower and slower. This is due to the presence of the inert gas, nitrogen, and to the ever-increasing mass of the burned gases. This increase in the mass of the burned and inert gases in propor-

tion to the combustible gases present, tends to separate and interfere with the mixing of the combustible with the decreasing supply of oxygen, and makes their union more difficult and retards their burning.

Tests made with brick-lined combustion chambers of extremely long lengths have shown that combustion takes place at a distance of more than 30 ft. from the bridge wall separating the grates from the combustion chamber; and indicates the effect of limited firebox and combustion chamber volume on fuel economy in locomotive practice. Heat losses due to high rates of firing and the attending reduction in air supply can be greatly reduced by the use of liberal combustion chambers; but this fact seemingly has not been appreciated.

(To be continued.)

### GARRATT TYPE LOCOMOTIVES FOR BRAZIL

The illustration shows a Garratt type locomotive which was recently built by Beyer, Peacock & Co., Ltd., Manchester, England, for service on the San Paulo Railway of Brazil.

This type of locomotive consists of three units: the two motor trucks and the boiler, on a rigid main frame. The location of the boiler on the frame is such and the frame is so connected to the trucks that an equal distribution of weight is effected on all driving wheels. The fuel and water are carried directly on the truck frames and as they decrease in amount the distribution of weight is not affected suffi-

ing obtained by a ball joint on the center line of the truck. The movement here being very small, little wear takes place. Originally, locomotives of this type were designed with a single exhaust pipe through which the exhaust from the motor truck cylinders was discharged. Owing to the fact, however, that the exhaust from the two trucks has not always remained in synchronism, the beats become irregular and vary in intensity, thus giving an irregular draft on the fire. When the engine is working very hard, there is also a tendency for the exhaust to create a detrimental back pressure unless the opening is so large as to be unsatisfactory under medium or light loads. These engines are now provided with separate exits for the two units, one being concentric with the other and the areas being made equal to each other.

The San Paulo locomotives are designed for a 5-ft. 3-in. gage and have driving wheels 60 in. in diameter. Each engine unit has a wheel base of 13 ft. 10 in., the rigid wheel base being but 6 ft. The ability to negotiate sharp curves is therefore apparent.

The cylinders are four in number and are all simple, the diameter being 16 in. and the stroke 24 in. The locomotive is fitted with a superheater, and the steam is distributed to the cylinders by the Walschaert valve gear.

The engine has no tender and may therefore be operated equally well in either direction. The total water capacity of the tanks is 1,500 gal., of which 850 gal. is accommodated in the smokebox end and 650 gal. in the firebox end. A fuel space for 2½ tons of coal is provided at the latter end.

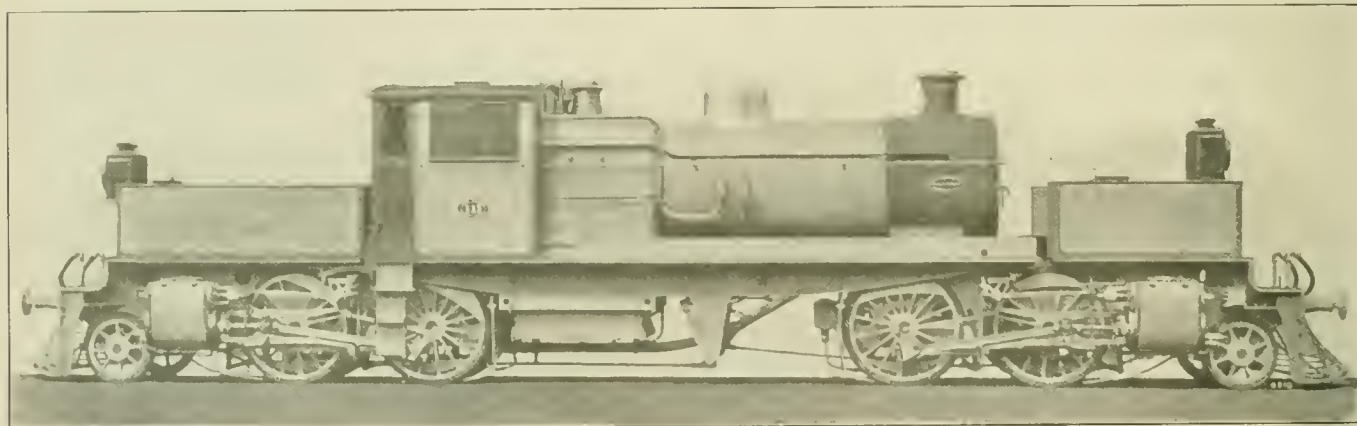

British-Built Garratt Type Locomotive for the San Paulo Railway, Brazil

ciently to have any appreciable effect upon the running of the engine.

The operation of the engine on curves is similar to that of a car with trucks at either end. The center line of the boiler and frame forms a true chord to the curve over which the locomotive is running, the sharper the curve the more the inside overhang of the boiler. The center of gravity of the boiler is thus brought inside the center line of the track and a greater resistance to the centrifugal overturning action is thereby effected. This is said to be borne out in practice, the steadiness of engines of this type on curves at high speeds being very noticeable. The outer rail on curves is also relieved of part of the centrifugal pressure which it must resist with other types of locomotives, and the remaining pressure is divided into two parts acting at considerable distances from each other. This fact is reflected in the life of tires which is said to be considerably longer than with other types of locomotives.

The freedom from restrictions imposed by the running gear in the design of the boiler is evident. The boiler may be kept lower and still permit the design of a firebox of any dimensions desired without interference from the wheels.

The steam pipe arrangement is simple, the flexibility be-

Some of the principal dimensions of the San Paulo locomotives are as follows:

	<i>General Data</i>	
Gage .....	5 ft. 3 in.	Coal
Fuel .....	27,850 lb.	
Tractive effort .....	6 ft.	
Wheel base, rigid .....	13 ft. 10 in.	
Wheel base, unit .....	47 ft. 10 in.	
	<i>Cylinders</i>	
Kind .....	Simple	
Diameter and stroke .....	16 in. by 24 in.	
	<i>Valves</i>	
Kind .....	Piston	
Valve gear .....	Walschaert	
	<i>Wheels</i>	
Driving, diameter over tires .....	60 in.	
Engine truck wheels, diameter .....	36 in.	
Trailing truck wheels, diameter .....	36 in.	
	<i>Boiler</i>	
Style .....	Belpaire	
Working pressure .....	160 lb. per sq. in.	
Outside diameter of first ring .....	64 7/8 in.	
Firebox, length and width .....	67 13/16 in. by 63 1/2 in.	
Tubes, number and diameter .....	183—2 1/8 in.	
Flues, number and diameter .....	24—5 1/2 in.	
Tubes and flues, length .....	10 ft. 4 1/2 in.	
Heating surface, tubes and flues .....	1,396 sq. ft.	
Heating surface, firebox .....	145 sq. ft.	
Heating surface, total .....	1,541 sq. ft.	

Superheater heating surface.....	304 sq. ft.
Equivalent heating surface*.....	1,997 sq. ft.
Grate area .....	30 sq. ft.

Tank

Water capacity .....	1,500 gal.
Coal capacity .....	2 1/4 tons

\*Equivalent heating surface — total evaporative heating surface + 1.5 times the superheating surface.

## PREPAREDNESS—THE HUMAN ELEMENT

BY JOHN H. LINN

Nowhere is there greater need for preparedness than in the mechanical department of our railroads. Long ago the railroads realized the need for preparedness in locomotives and cars and in shop plants and shop machinery and the material which enters into their construction. Have they made sufficient effort to prepare and train the men who are to man the shops, set up and operate the machines, and to do the thousand and one jobs incident to the building and repairing of locomotives and cars?

Whether the government, if the proposed plans for national preparedness are adopted, builds additional arsenals and ammunition plants of its own, or arranges to use the shops already manned and equipped by the manufacturing concerns or railroads, many of the mechanics who do this work will necessarily be recruited from those now working on locomotives and cars. Where are the additional men to come from? Those railroads which have adopted modern advanced systems of apprenticeship are indeed fortunate for they have practically solved the question so far as mechanics for the ranks are concerned. This is a big step in advance and the other roads might well profit by the results these pioneers are achieving, but we must not be content in preparing men for the ranks. This article is intended not so much to discuss the selection and preparation of men for the ranks but of men who are to lead and guide the rank and file and the countless other men who are needed to fill the numerous special jobs which arise in the mechanical department.

It has been said that if we take care of the men in the ranks the leaders will take care of themselves. This sounds all right, but will not work out to a satisfactory solution. It is possible in our army and navy for a Fred Funston to work up from among the volunteers, but were all our best leaders obtained in this way we would not have our splendid schools at West Point and Annapolis; neither would such care be taken in the selection of men who are to be trained in these schools. Neither can we trust to the survival of the fittest with no thought of the conservation or development of the many others capable of making good under right conditions. In the struggle for survival a Lord Kitchener may be lost while the deckhand survives. Neither can we afford to trust the selection and promotion of these men to chance or favoritism.

Too many capable men are shut in blind alleys. Too many good men are held in their present places by selfish foremen, who think only of immediate gain or their own personal advancement. Are not the interests of the company best taken care of by taking care of each man's best interests? Surely a man should not be denied promotion because of making good where he is.

If we are to secure the best men and get the most out of them we must be sure that each man selected is intrinsically worthy and that his qualifications particularly fit him for the job in question, and that the experience which he has already received and which he may still receive is such as to guarantee his making good. The man may be a good man, capable of success elsewhere, and yet fitted neither by nature nor training for the job in question. Too much care cannot be taken in fitting the man for the job.

When the sower went out to sow, the seed which fell upon the stony ground was perhaps just as good seed as that which

fell upon good soil. The modern, scientific farmer knows that if he is to raise a good crop he must be careful in the selection of the seed with which he starts. He must know that it is not only a good variety, but that it possesses sufficient vitality to insure its germination, and he must also consider the soil and the season. One field will raise good alfalfa while another had better be planted in corn, or wheat, or cotton, or rice.

And so it is in the mechanical world. Every manufacturer knows that if he is to compete in the open market, if he is to hold his present trade and hope to secure new customers, he must be very careful in the selection of the raw material from which he makes his product, and so we have our trained, experienced inspectors and expensive testing plants, every bit of material being carefully selected not only in reference to its intrinsic value but with particular reference to the specifications approved for that particular job.

Each of the young men in our shops is a wonderful bit of mechanism. His body, mind, and spirit constitute a wonderfully complex and intricate whole. This mechanism is easily put out of balance and destroys even itself if an effort is made to operate it off the track on which it was meant to go. Just as the locomotive when off the track dashes over the precipice, butts into the cliff, or falls into the river, or topples over when it attempts to round a curve to which it has not been adjusted, so with these human mechanisms. But if once on the right track even though the grades may tax his strength or challenge all his powers, still if he and those who guide him skillfully and intelligently manipulate the levers and valves and brakes there is no limit to what he may accomplish. Is it not certain that in our shops today are many an Edison, Westinghouse, or Baldwin?

Much has been said about fitting square pegs in round holes, and round pegs in square holes. If it is important to be so careful in the selection of material in the inanimate world, how much more need is there for care in the selection and training of the human element?

How are these men to be selected? Certainly only haphazard results will be obtained if they are selected by any haphazard method. Is not the question of sufficient importance to justify an organization with some central head to recommend men for promotion? Is not the power in these human engines as worthy of conservation and development as that in our power houses?

Where there is a central apprentice organization this department is in a position to handle the matter, for it should already have knowledge and record of its apprentices and apprentice graduates. The older men should not be forgotten, but naturally the best results will come from the young men, particularly those who have served their apprenticeship. The apprentice instructor should get so close to these fellows as to know their every ability, their every ambition. Unless he does this he is not in a position to say what each can do or what he cannot do. As he learns of certain qualifications which may fit him for special work or for leadership, he should pass this knowledge on to the master mechanic and to the supervisor of apprentices, or whoever has charge of maintaining the record and recommending men for promotion. The latter should not only keep thoroughly in touch with all these boys and men, but should keep a list of available material for each job for which men are likely to be needed, and when a vacancy occurs should carefully investigate the merits of all such available material so as to be able to recommend the man who gives most promise of making good.

What qualifications should be considered paramount? The answer depends upon the nature of the job to be filled. Some of the general qualifications, however, which should be considered are the man's ability as a mechanic, the experience which he has received, his education and training, his parentage and home environment, his habits and morals, his

physique and health, his personal appearance and personality, his industry and ambition, his self-confidence and assertiveness, his discretion and tact, his ability to mix, his "pep" and "sticktoitiveness," his action under fire, his ability to lead and to guide, his loyalty and love for his work and for the company by whom he is employed.

When the man has been promoted he should still be looked after and guided. A certain amount of responsibility and heavy grind may be necessary to temper the metal which is in him. But he should not be left to sink or swim with no rescuing hand near. Many a man has been lost when beyond his depth, who, had he remained a little longer in shallow water, especially with proper training, could have readily learned to swim the tide. One good act or deed well performed does not constitute success. Neither does one mistake constitute failure. A child falls down many times when learning to walk. Yet every one must learn to walk before he can run. Let us be firm, yet patient with these men. Materials destroyed may be replaced and their value determined, but who can replace a life destroyed or estimate the possibilities which it might have achieved if well directed?

## A QUESTION OF PROMOTION

BY GULF

I wonder if Thompson inspired that editorial on "Are You Guilty?" in the last issue of the *June Daily*.<sup>\*</sup> It sounds like an echo of his experience, because you know echoes are always reversed.

No, Thompson wasn't promoted, and I don't think he regrets it. You see it was this way:

Thompson was a hustler—the real article, with a lot of ambition mixed up with his hustling. He was thorough, too. When he left college his first move was to learn the machinist's trade and perfect his drawing and then when an opening came in the master mechanic's office of the A. B. C. Ry. he jumped into the place and proceeded to make good.

He didn't know much about locomotives, but he had a head on his shoulders and wasn't afraid of work. In fact, didn't know what it was. He declares now that he never did a day's work in his life. It has been one long, joyous holiday of play. He had the enthusiasm of youth, with the love of machinery that the artist has for the beautiful. He spent eight hours a day at the drawing board and six outside, studying to solve the problems that rose ahead of him, and the "Old Man" soon got to trust him because he made no mistakes. He was working for love of doing and in hope of appreciation.

The A. B. C. wasn't very progressive. It used Eight-wheelers when its neighbors had gone to Consolidations, and it standardized its valve motion, by using the same gear on switchers that it did on its fast passenger engines, because it had a template for the link. There were a lot of little things like that that Thompson, as he learned things, was itching to correct. He was so much of a machinist that the men in the shop respected him and came to him for pointers on methods of doing work. Oh, he was making good, all right!

But there was a consolidation and the "Old Man" went to a new office, where he had a real drawing room, clean and airy, not a drawing table by a window looking out on a round-house roof where Thompson was ecstatically learning locomotives.

Of course, Thompson expected to go with the "Old Man." But he didn't, nor did his chief clerk, nor did any one else. The new chief draftsman (mind you, Thompson had been simply "draftsman," the one and only) was brought in from outside.

Thompson was no fool and no egotist. He sized up the Interloper at short notice and saw that he was the better man

of the two. Broader experience, and all that; still he would have liked mightily to have had the chance to show what he could do. He didn't complain and was frank enough to say that the "Old Man" had gotten a better man when his fellow employees said that he ought to have had the job. But he kept his eyes opened, and proceeded to find out what the other fellow knew.

Well, it was the old story. A man who loves his work and so does it well soon has opportunity knocking at the door, and it was not long before the knocker on Thompson's door was thumping. Opportunity offered him an industrial position at higher pay. But Thompson loved a railroad and a locomotive, and went to the "Old Man" and laid his case before him.

"I don't want to leave, I like it here. The salary doesn't influence me. But what are my chances for promotion?"

"Well," said the 'Old Man,' "promotion comes pretty slowly on this railroad. I don't want to lose you, but I guess you'd better go."

And Thompson went, and took his hustling enthusiasm with him. Of course, it counted as an asset in his career, and he proceeded to climb. In a few years he was superintendent of a large manufacturing concern, but never lost his old love for the locomotive and always called at the old office of the A. B. C. headquarters when he was in town. As years passed, he always found the Interloper at the same drawing table; his old office mates were always at their old book, and it was only in the upper office that he found new faces. Why? Well, he was always told that they were too valuable where they were to promote. He asked as to salaries and found that the Interloper, whom he had once envied, has been raised ten dollars a month in 10 years—because he was too valuable to promote.

But Thompson still grew and, being an outsider, even the A. B. C. regarded him with respect and he was sometimes called into their councils. Then he found that they were all outsiders. They had grown up under different systems, with different ideals. Each felt a little jealous of his neighbor. Each fought for departmental rights and the A. B. C. paid the bill.

And Thompson, as he grew and was consulted by all of the roads from the A. B. C. to the X. Y. Z., found many interesting things. Where the officers were outsiders, he found jealousy, suspicion, selfishness and all uncharitableness. But where the president had been an office boy at his own door, where the chief engineer had been a rodman and the superintendent of motive power had been an apprentice, and all had grown up in the service, he found a harmony of action and a teamwork that would have done credit to any ball-playing organization on earth. It was the railroad first, last, and all the time, and departmental jealousies were hidden in the darkest of closets.

Thompson often wonders what would have happened to him if the Interloper hadn't come in. Possibly he might have stagnated in his surroundings; probably not. The A. B. C. did not go broke because it lost Thompson, but it did lose a very loyal and efficient servant, just the same, when it didn't give him that draftsman's job. I wonder what the increase in the number of Thompsons in the railway service would be, if more officials could plead, "Not Guilty."

UNITED STATES STEEL TRADE.—The United States has furnished nearly 80 per cent of Great Britain's imports of semi-finished steel since the war started, whereas previous to the war the United States furnished less than 20 per cent of such imports, and Germany nearly 80 per cent of the total. In the first two months of this year the United States furnished 84 per cent of the British imports of semi-finished steel.—*Iron Age*.

<sup>\*</sup> Daily Railway Age Gazette, June 22, 1916, page 1508.

# Car Department

## THE CAR INSPECTOR AND HIS JOB

The following extracts are taken from contributions which were made to the car inspectors' competition, which was held the latter part of 1915:

BY MICHAEL GLENN

Car Inspector, Cincinnati, New Orleans & Texas Pacific, Ludlow, Ky.

A car inspector must be bright, intelligent, sober, and know how to obey orders. He should first work on the shop repair track for about two years in order to know all the parts of a car, how to repair a car, to realize when wrong repairs have been made, to know how to test air brakes, and to understand the safety appliances requirements. He should then serve for one year as an oiler and obtain a thorough understanding as to how to oil and pack the boxes and know when a journal needs to be rebrassed. For the next year he should serve with the chief interchange inspector in order to learn how to recognize defects and just how they should be handled. He must, of course, know the M. C. B. rules of interchange and should understand when to issue M. C. B. defect cards and how to handle correspondence in the office of the chief interchange inspector.

After this preliminary training he can be given a position as car inspector, but for some considerable time should work in conjunction with a good car inspector of extensive experience. In addition to the routine work he should do his part in preventing claims caused by defective equipment; should do everything consistent and within his power to please the shippers, and work in harmony with the yardmaster. Obviously the car inspector should have a common school education; in addition to this he should attend night school for at least a couple of years.

BY JOSEPH DALZELL

Car Inspector, Pennsylvania Railroad, Pitcairn, Pa.

When a car repairman shows special ability in his work, knows all the parts of a car and how it is constructed, and can make light running repairs to brakes, draft gear, etc., he should accompany a car inspector and note the defects that condemn cars and send them to the repair shop; or he may be placed on a shop repair track in order to become familiar with shop practices. It is at this time that he should familiarize himself with the M. C. B. rules of interchange and be given practical instructions in repairing and inspecting air brakes. He must also prepare to pass the required examination for inspectors on the air brake and train air signal instructions.

Meanwhile, as he develops step by step, he should have an opportunity of becoming familiar with such things as ventilation, refrigeration and seal records. He must also understand the rules governing the loading of long material and should hold for orders those cars that exceed the clearance dimensions of his road. Then, too, he must be given special instructions concerning the application of safety appliances and the rules relating to the transportation of explosives and dangerous articles other than explosives.

He must understand many things in the railroad's book of rules so that he will know when an order or rule has been violated. He should also familiarize himself with the gen-

eral track conditions and their relation to car derailments and should be trained to furnish accident reports to his superiors.

BY W. S. CLARK

Foreman Car Department, New York Central, East Syracuse, N. Y.

Wherever possible, an employee who is finally elevated to the position of car inspector should first be assigned to repairing freight cars on a branch line in order to become thoroughly familiar with car instruction and have a clear understanding of the federal requirements concerning safety appliances. In most cases, however, it will not be possible for him to secure his experience in this way and he should be employed first as an oiler. Obviously one of the most important things to be done at the very outset is to instruct him in the principles of safety first and have him read and acknowledge receipt of instructions relating to the protection of inspectors and others working under or about cars. The oiler should be furnished with a copy of the instructions governing the care and lubrication of journal boxes and should be compelled to study them. The foreman in charge can check this by questioning the oiler from time to time and having him demonstrate that he understands the details of this work; in case he should not thoroughly understand any of the rules, his superiors should explain by practical demonstration.

When the oiler has proved competent in his work he should be promoted at the first opportunity to the position of a running repairman and should be instructed by the chief inspector as to how properly to make repairs marked up for him. The repairman's work should be checked closely and in case of mistakes he should have his attention called to them and be instructed as to how to make the repairs properly.

The next step upward should be to the position of car inspector. He should be provided with copies of the various rules and regulations which govern the handling of his work and should be accompanied by the chief inspector when he makes his first inspections. Moreover, the chief inspector should make it a point to quizz him on questions pertaining to the inspection and safe movement of cars and should promptly correct him on any point that he does not understand.

The chief inspector should hold meetings at least once each month for the instruction of inspectors, running repairmen, air brake men and oilers, and new inspectors especially should be compelled to attend these meetings. Among other things, the inspector should be impressed with the seriousness of a possible accident caused by his carelessness in inspection. He should be disciplined by suspension or dismissal if he persists in ignoring instructions or becomes careless in the performance of his duties. After being thoroughly trained he should be compelled to take a written examination every two or three months. His examination papers should be carefully checked, the percentage recorded and any errors brought to his attention in order that he may benefit thereby.

About 8,500 cars are handled through our DeWitt yard every 24 hours. These include 40 symbol trains in addition to the slow freights. There are six different inspection

points. The inspectors in the slow freight yards are instructed and trained just as thoroughly as those in the fast freight yards. This thorough training has caused practically the tying up of our wrecking outfits, as the inspectors do not allow any cars to leave the yards that will not stand up in present-day heavy trains.

The inspectors are trained to consult the train crews upon arrival in the yard to ascertain whether they have had any trouble on the road; this makes it possible to remedy any unsafe condition that might otherwise be overlooked. The inspectors are also instructed to report any defects on new equipment with a view to having such defects remedied as additional new cars are turned out at the car builder's plant.

**SPECIAL TOOLS FOR THE CAR DEPARTMENT\***

*Inspection Mirror.*—Considerable difficulty has been experienced in locating the defects in arch bars of freight cars and tender trucks, especially when the cracks occur on the inside of the bar. It is practically impossible to locate the defect by the ordinary methods of inspection. A very simple expedient has been tried and found to be remarkably

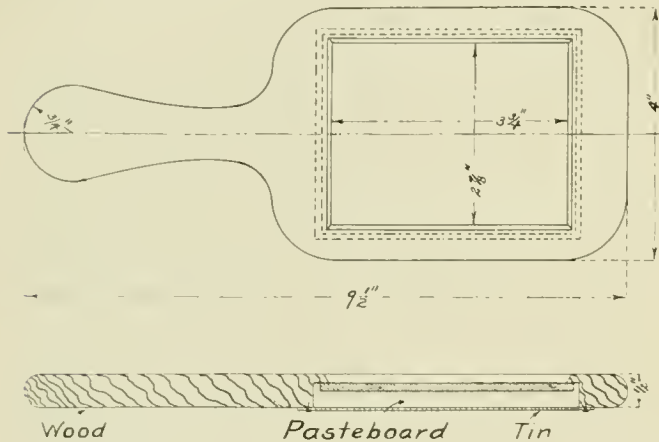

Fig. 1—Hand Mirror for Inspecting the Inner Side of Arch Bars

successful in aiding the inspector to locate these defects. The inspector is provided with a small hand mirror, such as is shown in Fig. 1. By holding it on the inside of the bar any crack or other defect can be readily discovered. The results obtained are astonishing. On one road in five months'

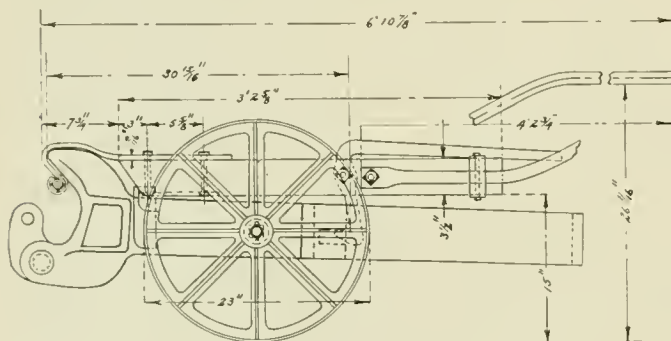

Fig. 2—Truck for Carrying Couplers

time, 1,488 failures were discovered which by the ordinary method of inspection would have been missed. Thirty-four broken bars were discovered in this way in two months at one terminal, forty-two at another in one month and seventy-six at another in ten days.

\*From a paper on Car Department Problems presented by E. E. Griest, master mechanic, Pennsylvania Lines, Ft. Wayne, Ind., at the General Foremen's Convention.

*Wagon for Hauling Couplers.*—It is necessary in every car department to transport considerable material from point to point in the repair yard. Any simple device which reduces the time and labor in handling material is worthy of consideration. In Fig. 4 is shown a truck designed for readily handling couplers. The wagon is tilted forward until the rear hook engages the cored hole at the end of the coupler shank. When the truck is again brought to a horizontal position, the coupler swings high enough off the ground to clear objects 6 in. high. With this arrangement couplers can be readily loaded, transported and unloaded by one man.

*Reclaiming Car Brasses.*—The common method of re-

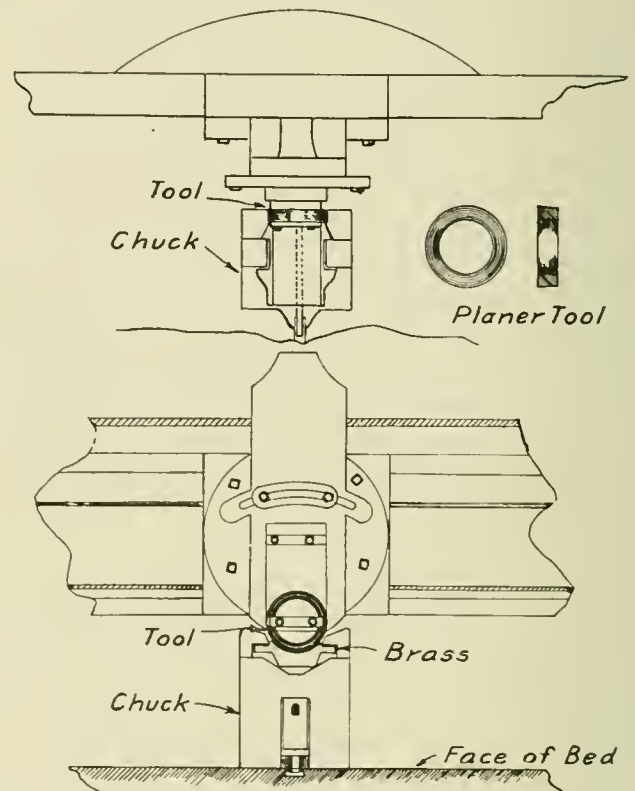

Fig. 3—Broaching Tool for Reclaiming Car Brasses

claiming freight car brasses when scored and unfit for further use is to remove the babbitt and renew it. In a large number of cases, the scored babbitt is still thick enough to be well outside the limits prescribed by the specifications. A saving could be effected if they could be cheaply rebored. In Fig. 5 is shown a method of performing this work on a planer by the use of a special planer jig and tool. The jig is fastened to the planer bed and clamps the brass by means of two fingers actuated by a wedge. The tool is merely a tapered ring with the large end of the same diameter as the standard journal, faced off flat to furnish a cutting edge. It is rigidly held in the tool head with the usual clamps. It may be revolved from time to time as the cutting edge becomes worn. It is estimated that through the use of this tool, a saving of over \$300 annually is effected at one shop where it is used. The price paid for reboring the brasses is \$.01 each.

*CRANKSHAFT ENDPLAY.*—Endplay of a crankshaft may be caused by the crankpin brasses being out of line and bearing alternately on opposite ends of the crankpin, or by the shaft being out of line, causing a wobbling motion of the flywheel, or, in a single-crank engine, by lost motion in the crankshaft bearing.—Power.

# PROBLEMS OF THE CAR DEPARTMENT

A Paper Presented at the Recent Convention of  
the General Foremen's Association, Held in Chicago

BY E. E. GRIEST

Master Mechanic, Pennsylvania Lines West, Fort Wayne, Ind.

It is the tendency on most roads to rely on the car foreman entirely for all matters connected in any way with the car department, the general foreman confining his activities entirely to the locomotive department; consequently, when he is promoted to a master mechanic, he has only a hazy conception of the nature of the work and importance of the car department. It is the purpose of this paper, through a discussion of some of the problems encountered, to call attention to the necessity for a more complete and accurate knowledge of car work.

The large railroads showed that the car department averaged 40 per cent of the total, and the locomotive department 60 per cent. The following itemized cost of operating a freight train of 50 cars 100 miles furnishes another indication of the relative amount of money spent in each department:

Locomotive maintenance	\$12.97
Fuel	10.44
Freight car maintenance	55.10
Total	\$78.51

Although the nature of the work is considerably rougher and can be handled to a large extent by unskilled labor with

There are operating today on the railroads of the United

TIME STUDY			OPERATIONS		TIME		
SHOPS	DATE				ACT	M.N.	
CLASSES All Parts of Wooden Baggage Cars	7/17/10		EXP. FWD.				
NAME OF PART Cap & Baggage sub. door stop							
PART No	B.P. No						
No OF PIECES 4	NET W. G.						
OPERATIONS Remove with upper W.C. sub. inc. bolt for hand hold.							
WORKMEN	RATE BY	CHY No					
WORKMEN	RATE BY	CHY No					
WORKMAN J. A. Bennett	RATE BY 20.2	CHY 703589					
TIME COMMENCED 8:51	TIME FIN. 10:22						
OPERATIONS	TIME	SUMMARY OF OPERATIONS					
	ACT M.N.						
Get material on platform	5:02 5						
Remove 1 wooden stop cap	9:5 5						
Fit iron cap	9:5 1						
Get material from stor house	9:5 3						
Applied cap - 12 No. 14 screw	9:21 13						
Removed 1 wooden cap	9:22 4						
Applied 1 iron cap	4:42 17	66-415		ALLOWED TIME		84	
Removed 1 wooden cap	4:46 7			% OF PIECES		4	
Applied 1 iron cap	10:1 10			Avg TIME PER PIECE			
Removed 1 wooden cap	10:6 5			PRICE PER PIECE			
Applied 1 iron cap	10:13 13			PREVIOUS PRICE			
	85			TIMES BY			
		TOTAL		REMARKS			
		ACTUAL TIME	85				
		TIME DEDUCTED FOR UNNECESSARY DELAYS	4				
		SKETCH OF PART					
		PRICE APPROVED					
							MASTER MEC-2110

Fig. 1—Form Used for Establishing Piece-Work Prices

States approximately 2,000,000 freight cars, the cost to maintain each of which is estimated at from \$80 to \$100 per year. Assuming \$90 as an average figure, the total amount expended annually in the United States for repairs and inspection of cars is approximately \$180,000,000. This is no inconsiderable part of the total spent for the maintenance of equipment. A recent comparison made of the car and locomotive department payrolls on a certain part of one of

a smaller investment for equipment, it does not necessarily follow that the problems that must be met and solved are any the less important or any the less difficult to solve. In a number of ways the larger problems are very similar to those in the locomotive department.

However, in at least one important feature car work varies from locomotive work entirely, and that is in the repairs to foreign cars. The M. C. B. Association has formulated a

code of rules governing the interchanging of and repairs to freight cars. Each railroad company is expected to give to foreign cars while on its line the same care as to inspection, oiling, packing, adjusting brakes, and repairs that it gives its own cars.

Considering that approximately \$180,000,000 is expended annually by the railroads of the United States for repairs to freight cars, and that conservatively estimated 20 per cent of this amount, or \$36,000,000, involves repairs to cars on foreign roads, and considering also that this enormous sum of money is exchanged between railroads without any definite means of checking against the work performed by repairing lines. It will be realized that the repairing of foreign cars and billing for the repairs occupies a unique position in business. There is perhaps no other line of business where such large sums of money are exchanged merely on the basis of common honesty. In order to protect the car owner, and that the principles upon which this important branch of railroad work are founded may be safeguarded, two things are necessary: First—adequate supervision; second—a thorough and efficient system of preparing original records and compiling charges from such records.

*Training Car Inspectors.*—It is no small part of a car foreman's duty to assure himself that his inspection forces are thoroughly familiar with and able to apply the M. C. B. rules governing the interchange and inspection of cars, the United States Safety Appliance Act, the Loading Rules of the M. C. B. Association, and the Tank Car Specifications. The best and easiest method to accomplish this is to see to it that the men who are promoted to inspectors have received proper training. A car inspector must be able to discover the parts which have actually broken down and defects which may develop into subsequent failures.

A car inspector should know something of the way in which repairs are handled on the repair track, and inasmuch as he must make repairs himself, it is almost a necessity that he be a proficient repairman. After being picked out as a prospective inspector, he should be moved about on various classes of work, so that when the time comes to use him as an inspector he will have had some training on every class of work, on truck work, on steel cars, on wooden car repairs, on light repairs to loads and empties. Some roads hold written examinations on the M. C. B. rules and all other rules governing the inspection of cars at stated intervals. Other roads have a division general car inspector whose duty it is to go from point to point where inspectors are stationed and by questioning ascertain whether or not the inspector has a reasonable working knowledge of the rules, and whether he is able to apply them. The training of a car inspector is by no means a simple task. It requires thought and careful attention. Once it is accomplished in a satisfactory manner, it requires more careful attention on somebody's part to see that the inspector does not become lax and inattentive.

*Hot Boxes.*—Hot boxes are a source of expense, which, if they could be eliminated entirely, would save considerable money in the course of a year. The average cost of a hot box is estimated at approximately \$10. This figure includes the cost of necessary switching and repairs, but does not include any of the expense incurred in wrecks, consequent delays to traffic, etc. Using this figure as a basis of an estimate, the total cost of hot boxes represents approximately 8 per cent of the total repair expense of the car.

The principal causes of hot boxes are:

1. The shifting of the sponging towards the outer end of the journal box, due to the lateral motion of the box, which draws the sponging away from the rear of the journal. An examination of the bearings and axles removed on account of hot boxes will show that heating in the majority of cases began at the rear of the journal.

2. Sponging too tight, due to excessive amount of waste. In forcing the waste into the box, the oil in the waste next

to the journal is forced out through the opening between the dust guard and its seat, the dry waste then acting as a wiper. It not infrequently happens, where this condition exists, that strands of waste are drawn up between the journal and the bearing, in which case a hot journal results.

3. Sponging glazed due to the waste not having been agitated, or set up with a packing knife at frequent enough intervals. Where this conditions exists, the oil cannot reach the journal.

4. Insufficient amount of oil in the sponging, due to its

Division.					
LUMBER INSPECTION CARD.					
Car No. <u>32439X</u>		Initial, <u>S. R. R.</u>			
From .....		Received .....			
PIECES.		SIZE	KIND	FEET.	
Good	Gulled			Good	Gulled
		3/4 x 8 x 7	Cl. Oak		
5		1 1/4 x 1 1/4 x 9 1/4	" "	709	
7		1 1/4 x 1 1/4 x 9 1/4	" "	831	
4		1 1/4 x 1 1/4 x 10	" "	174	
1		7/2 x 1 1/2 x 10	" "	78	
4		5 3/4 x 7 3/4 x 7	Sh. "	184	
1		6 3/4 x 7 3/4 x 7 6	" "	33	
17		2 1/4 x 4 1/4 x 9	" "	187	
17		3 3/4 x 3 3/4 x 8	" "	160	
2		4 x 5 x 8	" "	29	
3		5 1/4 x 5 1/4 x 8	" "	92	
4		1 1/4 x 3 1/4 x 8	" "	398	
15		1 1/4 x 6 x 8 6	" "	111	
		2 1/4 x 4 3/4 x 8 6	" "		
10		3 3/4 x 6 1/4 x 8 6	" "	166	
9		4 1/4 x 8 1/4 x 8 6	" "	224	
6		2 1/4 x 10 1/4 x 8 9	" "	181	
17		3 1/4 x 10 1/4 x 8 9	" "	413	
11		1 x 9 1/2 x 9	" "	78	
1		3 1/2 x 4 x 9	" "	11	
8		4 1/4 x 12 1/4 x 9	" "	210	
Total, .....				4029	
Shipper's Claim, .....					
Excess or Deficiency, .....					
Inspected by <u>J. Egan</u>					
Correct: .....					
Date, <u>5/24/1916</u> .....				Foreman.	

Fig. 2—Form Used for Recording Inspection of Lumber

being syphoned away by loose strands of waste hanging out of the box. This condition may also be brought about by an accumulation of snow in the box. The snow melts from the heat of the journal, the water collecting in the bottom of the box lifts the oil and allows it to escape.

5. An excessive amount of oil which results in the waste falling away from the under side of the journal.

6. Worn out sponging. This results in practically the same defect as when an excessive amount of oil is used with good waste. The packing having lost its life, falls away from the



lower side of the journal, leaving it without a means of lubrication.

*Preparation of Sponging.*—The proper preparation of the sponging is important, both as a means of preventing an unnecessary waste of oil and in eliminating a frequent cause of hot journals. The waste used should be free from all foreign substances. Care should be exercised to see that the quality of oil presented for summer or winter use is used in the proper season. The waste and oil should be mixed in the proportion of 80 lb. of waste to 90 gal. of oil to insure a thorough saturation of the waste. This mixture should stand for 48 hours in a room in which the temperature is kept at from 68 to 70 deg., after which 50 gal. of oil should be drawn off, leaving the ingredients in the proportion of one gal. of oil to 2 lb. of waste, or 4 pints of oil to 1 lb. of waste. This should leave the packing in a condition so that when it is compressed in the hand the oil will just appear between the fingers.

*Car Apprentices.*—The apprenticeship system in the car department on some roads has declined to a point where there are few, if any, apprentices enrolled. The exact reason for this is not apparent. The need of apprentices is fully as great today and even greater than it was 10 years ago. If the ever-increasing cost of repairs is to be cut down to any appreciable extent, it must come about through the efforts of a more capable and better trained force than our present one. Old methods and old ideas must give way to improved ones.

An adequate apprenticeship system should provide for:

1. A sufficient amount of time spent in each department to give the apprentice a clear idea of that part of the work.
2. A rate of pay which would attract boys of some education.
3. Promotion for the better grade of apprentices.

The scheme adopted in most locomotive repair shops of having a definite schedule, according to which an apprentice serves a set amount of time in each department, ought to be just as applicable in the car department. A proposed schedule of this kind is given below.

FIRST YEAR	
Freight car repair tracks.....	6 months
Passenger car repairs.....	6 months
SECOND YEAR	
Pipe shop .....	3 months
Tin shop .....	3 months
Smith shop .....	3 months
Planing mill .....	3 months
THIRD YEAR	
Car machine shop.....	3 months
Paint shop .....	3 months
Air brake work.....	6 months
FOURTH YEAR	
Inspection of freight cars.....	6 months
Inspection of passenger cars.....	6 months

*Piece Work.*—Piece work in railroad shops has been in general use throughout the country for about thirty years, and yet it appears in the light of what has been accomplished in the industrial concerns that this important subject deserves further consideration. In most shops it is customary when a new price is to be established for performing an operation to set it in one of four ways: by a comparison with a price already in use in some other shop, or from an estimate of the time required to perform the operation as made by the foreman of the department affected, or through the action of a committee of department foremen from two or more shops, or by what is known as a time study or an accurate record of the time required to perform any one operation, taken by a man who has nothing else to think about save the particular operation upon which he is taking time.

It has gradually become apparent that the first three methods fail completely to meet the needs of the situation, and on some few roads an entirely different and more accurate method has been instituted. Men have been chosen from among the workmen whose duty it is to devote their entire time and thought to the accurate setting of prices and to their

payment. To accurately set the price, it is seen that the workman first provides himself with all the necessary tools and material to complete the operation. The workman is shown just how each operation is to be performed. Upon a blank form, a sketch of which is shown in Fig. 1, is entered the time required to perform each operation. If the operation is one which, if repeated, could be performed in the same length of time, the price is set on the basis of the time shown, with the time consumed in unnecessary delays deducted, basing the price upon approximately 40 per cent to 60 per cent in advance of the prevailing day rate for that class of work. But if the job is of such a nature that the time consumed in performing the same operation again would vary, as for instance in stripping, where nuts come off readily in some cases and must be split in others, a number of observations are made of the time required, and the price based on the average condition as indicated by these time studies. After the price is once set, these forms are filed away so that at any time where a question arises as to what was included in the price, reference can be made to the form.

*Dismantling Cars.*—With the increase in prices paid for scrap material, both for lumber and metal parts, the question has again arisen as to whether more economy could not be shown if cars were torn down and all material saved than if they were burned down, and some material wasted to save the increased labor cost of tearing down the cars. Up to this time it has always been felt that it would cost more in labor to reclaim such material than it was worth. Recent investigations seem to show that this is not the case. A study made on the comparative saving effected in burning and tearing down a number of box cars shows a distinct saving effected through tearing down the cars, as follows:

	Car cut up by hand	Car burned
Value reclaimed metal material.....	\$33.592	\$33.592
Lumber reclaimed .....	23.25	7.56
Scrap credits .....	23.12	23.12
Total value of all material reclaimed....	\$79.962	\$64.272
Cost to destroy .....	9.00	8.64
Net value of reclaimed material.....	\$70.962	\$55.632
Saving effected by tearing down cars, Per car torn down.....	\$15.33	

The work of tearing down these cars was all done day work with considerable room for improvement in methods and in the amount of material saved. The proposed plan of handling the work was as follows: Secure enough cars to fill one or more tracks with from 10 to 20 cars each, spacing them about 10 ft. apart; assign four men to each car, two of them to begin stripping off the roof and two to removing grab irons, brake staff and outside metal. The men removing the roof could, before leaving the top of the car, loosen the siding. After removing the roof, outside metal and doors, the four men could then take down the lining, loosen the belt rail and remove the siding. The upright rods should be cut at the floor level, the longitudinal rods should be taken out, the frame work thrown to the ground and the rods still remaining in the frame driven out. Two men could then remove the deck, while the other two men take down the draft rigging and remove the air brake material.

The work of cleaning up the track, assorting the metal, classifying and piling the lumber should be done by another gang of two men to each car. With this organization it was estimated that a gang of 6 men ought to tear down and pile and assort all the material from one car in eight hours.

There are a variety of uses to which reclaimed lumber can be put. The siding can be used for roof boards and for sheathing of buildings; car lining can be used for sheathing car sills for foundation work and framing. Car decking can be used for platforms. The scrap lumber is worth about \$2 a cord in the market, or about \$1 per car. The second-hand lumber can be estimated at about \$10 per 1,000 ft. reclaimed. The metal parts are in much better con-

dition for use when cars are torn down instead of being burned. From all the figures available, it appears that considerable economy can be effected by abandoning the practice of burning condemned cars.

*Handling Lumber.*—The value of the lumber handled in the average lumber yard connected with the car department will approximate \$20,000 a month, or \$240,000 annually. All lumber should be inspected on its receipt to insure that none is paid for which is not received, and that that which is not in accordance with specifications is rejected. Rejected lumber may be accepted at a lower price, and used for purposes other than that for which it was originally intended. A form which has been used with considerable success for recording the results of such an inspection is shown in Fig. 2. This form is printed on heavy glazed cardboard, and is made of a convenient size for the inspector to hold in his hand.

To economically purchase lumber for the large variety of purposes it is used for in the average car department, and to insure that the particular sizes are purchased on which there is the least waste in cutting it to the desired dimensions, requires a complete system of records. The records must be kept so that the total consumption of any one size can be accurately estimated for any stated period, as well as the amount on hand and the amount due but not received.

Car lumber yards must be arranged to fit local conditions, such as ground space available, track layout, convenience of delivery to shops, switching facilities, etc. In the arrangement of the piles the timber should be supported at enough points to prevent breakage, to permit a free circulation of air and to keep the timber drained of all moisture. The foundation should be arranged so that the bottom of the pile sets from 2 to 3 ft. above the ground to permit a free circulation of air underneath the pile and should be pitched so that the front end is higher than the rear end. The amount of this pitch varies, but successful results have been obtained where the pile is given a pitch of about 1 in. per foot. This amount will insure sufficient drainage and prevent any accumulation of moisture. Hardwood should be stripped every third tier, enough space being allowed horizontally between boards to allow a sufficient circulation of air. This supports the timber throughout its entire length, and still exposes enough surface to the air for drying. Dressed roofing, siding and lining should be stripped every other tier. It has been found that if dressed siding is stripped every tier a number of broken boards result.

## SPECIAL TOOLS FOR STEEL CAR REPAIRS

Beginning on page 470 of this issue there is published a report of the recent convention of the American Railway Tool Foremen's Association. While there are many car department officers and men who will be interested in the entire proceedings of this convention, special attention is called to the discussion on Special Tools for Steel Car Repairs, which appears on pages 472, 473, 474 and 475.

*ALLOWABLE STRENGTH OF WELDED JOINTS.*—According to the A. S. M. E. Boiler Code, "the ultimate tensile strength of a longitudinal joint which has been properly welded by the forging process shall be taken as 28,500 lb. per sq. in., with steel plates having a range in tensile strength of 47,000 to 55,000 lb. per sq. in."—*Power*.

*ZINC CONCENTRATE IMPORTS.*—A steamship load of Australian zinc concentrates consigned to the American Steel & Wire Company at Donora, Pa., arrived at San Francisco recently and was transferred into 141 cars and forwarded overland by the Atchison, Topeka & Santa Fe in four solid trains. From Chicago the freight went by the Pittsburgh, Cincinnati, Chicago & St. Louis. It is understood that this steamer will be followed by many others with similar shipments.

## SUGGESTIONS FOR THE CAR DESIGNER\*

BY CYRUS HANKINS

One may safely say that there are no perfectly designed cars nor any perfect car designers. There are, however, cars of designs so much better than others that it is plain to see the designers were capable and well qualified. It should be the aim of every designer to become equally as capable, and it should be the aim of every railroad to secure qualified men.

The gravity of poor design is too often not appreciated by the unfitted designer, and too often to the officers of a road any car is a car. But if all designers could fully appreciate that even the least excess of metal makes an addition to the first cost that is really astonishing and each year that extra weight, in many ways, is eating into the company's revenue, it is certain they would study to eliminate much unnecessary weight and expense. There are often cases where by better designing, a car, weighing, say, 45,000 lb., could have been made stronger and better fitted for service, with a saving of probably 2,000 lb. in light weight. This, depending on the market, would amount to from \$25 to \$40 per car for steel alone, and there are often 10,000 cars built from a single design.

The designer must be an engineer. A draftsman without any engineering knowledge may duplicate some other design of car and rearrange it to take certain standards common to his road, but that is about as far as he is able to go.

The designer must make a very careful study of the conditions under which the car may operate and the requirements that it must meet. He can get many valuable hints on what to avoid by careful observation of cars on the repair track. By a study of the Car Builders' Dictionary and of railway mechanical periodicals, a knowledge may be obtained of the typical designs of the past. There is no source of information so valuable to the car designer as the careful analysis of previous designs, especially if he has available information as to their service record. The designer should not, however, fall into the rut of designing only by proportionately increasing old designs and not giving himself the chance to do any original work. He must not blindly follow any old design, but learn to determine the functions of each part and design accordingly.

A thorough familiarity on the part of the designer with the practice of the local shops and with their limitations is essential. It is well to consider carefully any suggestions coming from the shop and incorporate them in the design wherever possible, not only for the value of the suggestions themselves, but for the psychological effect on the men who will have to deal with the cars after they are built.

The designer should not be compelled to use specialties which he knows are not suited to the car in question. Very often they are specified, even against the advice of the mechanical department, certain devices that subsequently prove to be worthless. The designer should at least have a voice in the selection of every specialty that goes on the car. Often the substitution of one commercial device for another will be of great assistance in working out other details of the design. The car designer must not only be capable, but must be allowed time in which to do his work. No designer can get the best that is possible on his first trial. He should have time to make several study designs before a working design is finally selected.

*TIMBER PRESERVATION.*—To preserve timber from decay it is treated with an antiseptic, such as creosote or zinc chloride. Creosote is the oldest known preservative and one of the best. Creosote oil is insoluble in water, and has a boiling point of over 4,100 deg. F.—*Power*.

\*Entered in the competition on "How Can the Car Designer Improve?" which closed June 1.

# ERIE RAILROAD 50-TON HOPPER CARS

Self-Clearing, Triple-Hopper Arrangement; Special Attention Has Been Given to the Side Bracing

THE standard design of car used by the Erie Railroad for transporting coal is a self-clearing triple-hopper-bottom car. By referring to the photograph and drawings of one of these cars, 1,000 of which have recently been built by the Pressed Steel Car Company, it will be noted that

therefore, the lading can be discharged more rapidly and with less labor.

These cars have a special feature in the construction and bracing of the sides. Where outside vertical stakes and inside tie braces tying the sides together are used they are

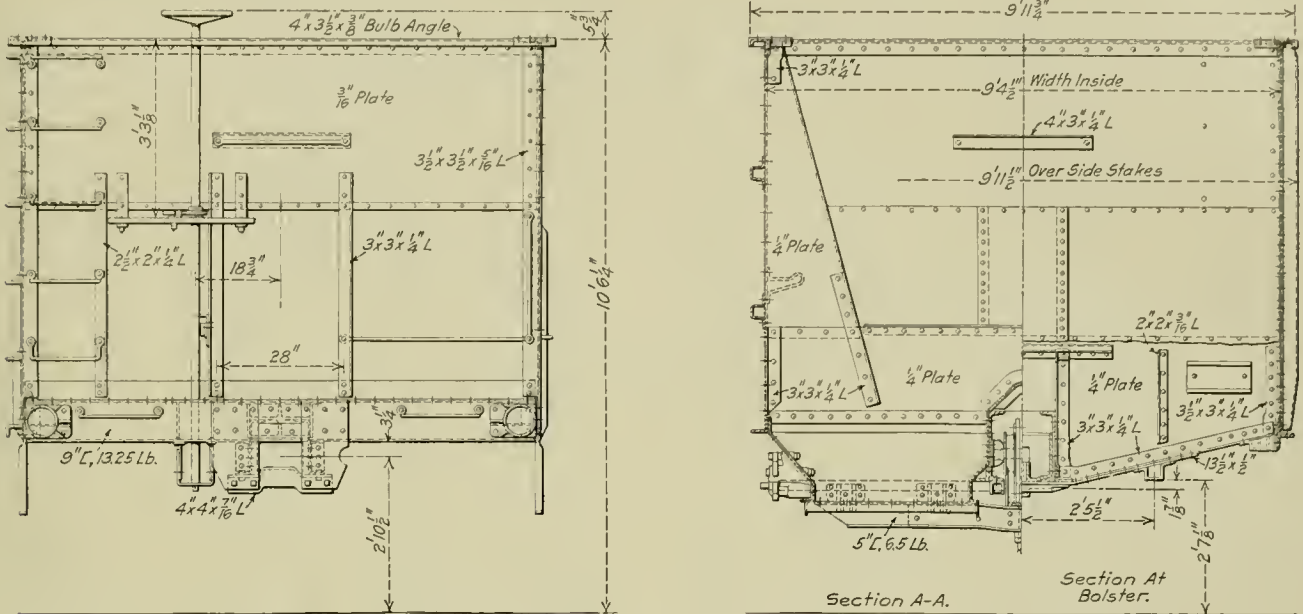

End Elevation and Cross Sections of the Erie Hopper Car

the bottom is equipped with three sets of doors. Each opening is provided with two doors hinged crosswise of the car. The doors are opened in multiples of four; that is, two pockets, one on each side of the center sill, are operated from

sooner or later damaged, the side stakes from being side wiped and the tie braces from the lading. The sides on these cars are braced differently from the usual practice, and instead of using outside vertical side stakes spaced at regular



Erie Railroad 50-Ton Capacity Hopper Car

one operating shaft. With this arrangement of hoppers, large and direct openings for discharging the lading are obtained. The total opening is from 30 to 50 per cent greater than with the standard double hopper bottom type of car and,

intervals between the bolsters, and bracing the sides by tying them together with tie braces, the main bracing on the outside is longitudinal and on the inside vertical. There are two pressed steel stakes on each side, one at each bolster. These

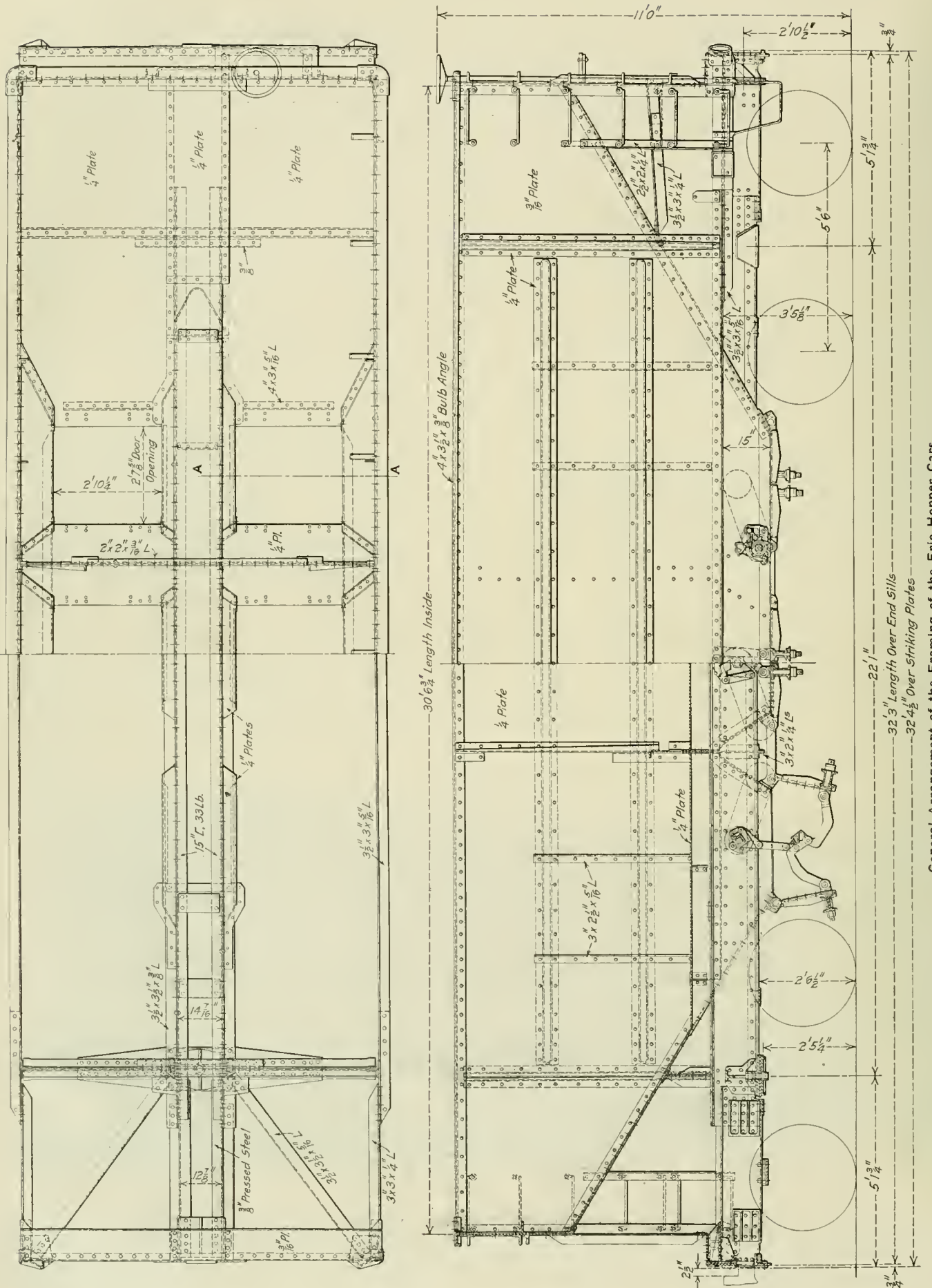

General Arrangement of the Framing of the Erie Hopper Cars

two stakes are well braced, being anchored to the end of the body bolster girder. Between the bolsters the sides are braced on the outside with four longitudinal members. One is at the top of the car and consists of a 4 in. by 3½ in. by 1½ in. by ¾ in. bulb angle, continuous from corner post to corner post. At the bottom of the side is a 3½ in. by 3 in. by 5/16 in. rolled angle continuous between points just beyond each body bolster. Between these two rolled members, and spaced about equally, are two pressed steel stiffeners extending from bolster to bolster. On the inside there are two heavy triangular-shaped gusset plate braces. These extend from the top of the sides to the cross girders and have a width at the bottom of about one-half the distance between the side and center sills. There are four additional vertical stiffeners, made of angles, on the inside and spaced equally between the bolster and the triangular-shaped gussets. It is found that this construction stands up very well and repairs are small when compared to the usual construction of having all vertical side stakes on the outside, and inside cross tie braces.

With the exception of the end sheet, the end side sheet and the end sill cover plates, which are 3/16 in. thick, the plates used throughout are ¼ in. The cross ridges, which at the same time form cross girder constructions, each consist of a vertical web plate running from side to side of the car and extending from the bottom to about 20 in. above the top of the center sills. These are reinforced at the bottom with two angles, extending from side to side, which pass below the center sills, and at the top with an angle extending between the side gusset plates which are attached to the top of these plates. To this plate, about in line with the top of the center sills, are also attached four sheets which slope down to and form one side of the door opening to which the drop doors are hinged.

The center sills consist of 15-in., 33-lb., rolled channels, with the flanges turned in, reinforced at the bottom on the outside with a 3½ in. by 3½ in. by ¾ in. angle extending from draft rigging to draft rigging. To these sills, in front of the body bolster, are spliced ¾ in. thick pressed steel draft sills. The body bolsters are of the usual single web construction. The end sills consist of 9-in., 13¼-lb., rolled channels, backed by a heavy steel casting behind the coupler horn striking face.

The specialties used are New York air brakes, Simplex, Gould and National Malleable Castings Company's couplers, Reliable uncoupling device and Miner friction draft gear with forged steel yoke. The trucks are of the cast steel side frame type, having 5 in. by 5 in. by ½ in. spring plank angles, and are equipped with Simplex bolsters having Miner side bearings, M. C. B. brake beams, steel back brake shoes, Barber roller device, cast iron wheels, Gould journal boxes and drop forged wedges.

The length of the car over coupler striking faces is 32 ft. 4½ in., the height from rail to top of side 10 ft. 6¼ in. and the width over-all 10 ft. ¼ in. The cars are of 100,000 lb. capacity, level full, hold 1,880 cubic feet and have a weight of 41,000 lb.

**PIPE MATERIAL.**—Pipes and tubes are made of a great variety of materials, the most common being iron, steel, copper, brass, lead and tin. In recent years two or more metals have successfully been mechanically combined as a lining or covering for special purposes, aside from galvanizing, tinning or plating by the hot process or by electrically depositing one metal upon another.—*Power.*

**REMOVING PULLEYS.**—Removing pulleys that have been rusted on shafts is frequently a troublesome job, but can generally be accomplished by heating the hub with a charcoal fire or some other means. The hub will expand, and the wheel can be easily removed. Care should be taken, however, not to heat the shaft, for if it expands as much as the hub nothing is gained.—*Power.*

## METHOD OF PACKING JOURNAL BOXES\*

Where it is necessary to entirely repack a journal box, all of the packing should be removed and the box carefully cleaned of all grit and dirt. A handful of packing, rolled and twisted into the form of a rope, should be inserted first in the back of the box to act as a dust guard as well as filler. The box should then be filled with sponging up to the center of the journal, the centering hole in the end of the axle serving as a guide for the proper height. Care should be exercised to keep the packing inside the journal collar, and that the box is not too tightly packed. A handful of packing should then be placed in front of the journal as a wedge to keep the packing on the sides in place. This should have no connection with the packing on the sides or beneath the journal. Care should be exercised to see that no loose ends of the packing hang out of the box which can act as syphons to draw the oil out of the box.

It is important that the box be not filled above the center of the journal as packing above that point is liable to be caught and drawn in between the journal and the bearing, producing friction, which results in numerous hot boxes. A box thus packed should be in condition for 6 months' service without complete repacking. At the end of every 400 miles, however, the packing should be sponged, i. e., the well saturated and fresh packing should be brought up from the bottom of the box to the underside of the journal.

## STEEPER END SLOPES FOR HOPPER CARS

BY F. S. INGOLDSBY

The fundamental of a dump car is to dump; but many railway officers content themselves with cars which are partial dumpers, when for the same money they could have complete dumpers. It is just a matter of placing the end slopes at the proper angle of inclination, so that the entire load will run out when the doors are opened.

By examining the general run of coal cars in service it will be found that their end slopes are only 30 deg. from the horizontal. Watch the unloading of such cars; from two to eight men are employed, and from the moment they begin on a car until they are through with it they consume 40 min.—the eight men taking 5 min., or the two men 20 min. Multiply this 40 min. for the one car by the thousands of unloadings which occur daily on the railroads throughout the country and the waste of time and money is seen to be enormous.

By simply steepening the end slopes this time can be reduced to one minute per car; but so long has this faulty design been adhered to, that the 30 deg. end slope is accepted by the majority of railway officers as inspired. However, it can be changed, and it has been changed, notably on a large number of cars which have been running on the Chesapeake & Ohio for more than two years.

Until 1913 the 30 deg. end slope was accepted on the Chesapeake & Ohio the same as elsewhere, but Frank Trumbull, chairman of the board of that road, led those under him to question its sanctity, and as a result the cars ordered at that time were changed so that their end slopes were 20 deg. steeper, or 50 deg. from the horizontal, notwithstanding the fact that car builders and others said it could not be done. These cars have a rated capacity of 70 tons, and one of them has been loaded with 79.9 tons of soft coal, thus proving that the cubic capacity was more than ample for the rating. No doubt when these facts become well known it will not be long before practical tests of the two slopes will be made by other railroads, and once that is done there will be no more 30-deg. end slopes to eat up the time and money of our coal-carrying railroads.

\*From a paper on Car Department Problems presented by E. E. Griest, master mechanic, Pennsylvania Lines, Ft. Wayne, Ind., at the General Foremen's Convention.

## THE READJUSTING OF YARD INSPECTION FORCES

BY J. E. HELMS

It is probable that the handling of both freight and passenger trains through yard terminals with men classed only as car inspectors, has never been tried to any large extent in a practical manner. The practice adopted in the majority of yards is to have men who do the inspecting; oilers who do the oiling, repacking and rebrassing; air brake men who make repairs and test the air brakes on trains leaving the yard; and light repair or safety appliance men who look after safety work.

This necessitates in the handling through any yard of, say, 12 or 15 hundred cars each 24 hours, a force of 10 inspectors, 5 or 6 air brake men, 4 oilers and 2 or 3 safety appliance or light repair men. Classifying men in this manner is very good, providing the work to be done comes in gradually and moves out in the same manner, but when the yard becomes congested, as it does every day, especially in freight yard service, it is almost impossible to accomplish the work with any degree of exactness, simply for the lack of not being able to place the yard men most effectively on account of their classification. With all of the men classified as car inspectors, each one competent to do any kind of work, the work could be performed much more expeditiously than it is now.

The argument may be put forth that the additional cost in wages would make this plan unprofitable. With proper supervision of the men, when once the plan is inaugurated, it would expedite the handling of cars and trains to such an extent through most yards that much of the waste time in getting cars in and out of terminals would be avoided, with a consequent saving for the operating and traffic departments.

## CO-OPERATION IN DESIGNING CARS\*

BY A. H. LAKE

My experience as a car draftsman leads me to believe there is not a sufficiently close relationship existing between the railroad drafting room and the departments using and repairing the cars.

The draftsman has very little opportunity to see the cars, the drawings of which he has made, either during their construction or after completion, the inspecting generally being done by men who never visit the drafting room. While the inspectors give many valuable suggestions, these suggestions pass through so many hands that by the time they reach the draftsman they have lost most of their value. This also applies to the suggestions from the operating department.

The principal car shops and repair tracks often are not located at the same point as the drafting room. The result is that a great many changes are made on the cars of which the draftsman has no knowledge and when he prepares a new design he may make use of details and specialties that have proved wholly unsuited for the conditions of the service. The principal car shops, repair tracks and drafting room should be located at the same point, and the draftsman should have access to the shops at any time during working hours. He should visit the shops several times during the course of construction or repairing of cars in the design of which he has taken part, thereby becoming familiar with shop methods and noting any defects which may have developed in service in order that they may be avoided in the future. The shop foremen and inspectors should have access to the drawing room at all times and so familiarize themselves with the problems which confront a draftsman. Only by the establishment of such relations between the men who repair the

cars and the men who design them can the existing conditions be improved.

If a large number of cars are being built at an outside contract shop to the drawings and specifications of the railroad company, it would be advisable to have one or more of the draftsmen who worked on these drawings act as inspectors for a short time during the construction of the cars, thereby getting some knowledge of their shop methods.

## WATER COOLERS FOR PASSENGER CARS

BY GEORGE E. McCOY

Assistant Chief Draftsman, Canadian Government Railways, Moncton, N. B.

The accompanying illustration shows a design of water cooler which has recently been applied to an order of steel sleeping cars, built by the National Steel Car Co., Limited, Hamilton, Ont., for the Canadian Government Railways. The outer tank which holds the ice is built with double walls, between which is placed the insulating material, either granu-

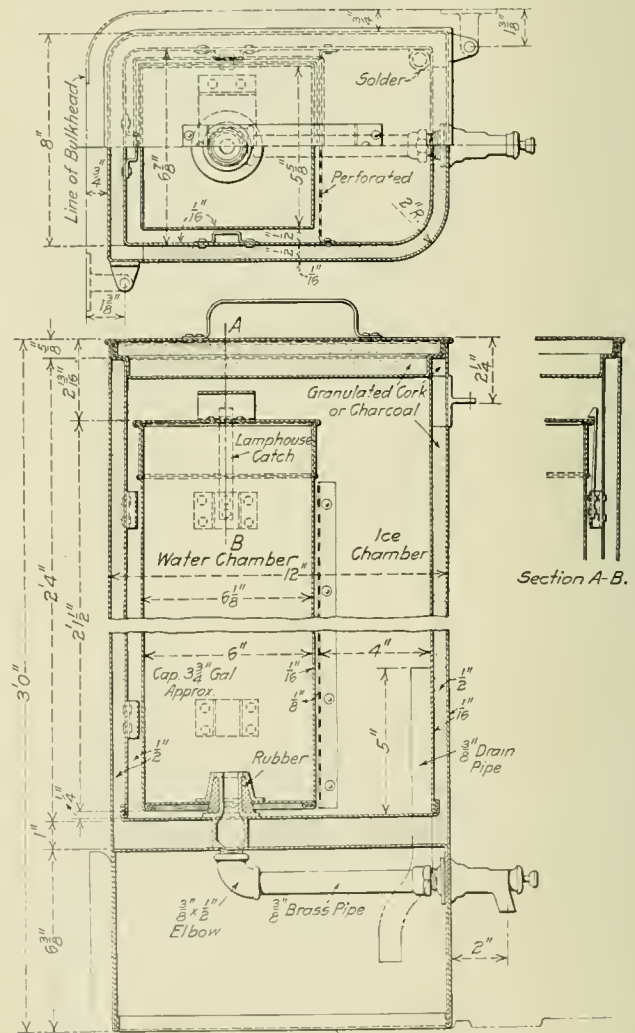

Water Cooler Used on Canadian Government Railways

lated cork or charcoal being used. The water container is placed within the ice tank and a socket in the bottom fits over a taper rubber plug surrounding the outlet to the faucet. This provides a tight joint, without in any way interfering with the quick removal of the tank. It will be noted that the ice is separated from the water tank by a perforated plate which prevents the latter from being injured by coming into contact with the ice.

\*Entered in the competition on "How Can the Car Designer Improve?" which closed June 1.

# Shop Practice

## FINISHING AIR PUMP PACKING RINGS

BY F. R. STEWART

It has long been the practice to turn air pump packing rings after they have been cut at the proper angle, but most of the methods used are slow and inaccurate, especially so if the piece cut out is  $\frac{3}{8}$  in. or more for rings 8 in. to 9 in. in diameter. This practice means longer life for the cylinder, and greater efficiency for the pump, and in order to maintain this efficiency, cylinders should be rebored when

is fitted to a Bullard vertical turret lathe with constant speed motor and quick changes of table speeds.

The chuck is made up of a mandrel *A*, a sleeve *B*, and the cap *C*, the last being placed on the mandrel after the bushing and held in place by a key of rectangular section, which passes through the cap and the end of the mandrel. A set of sleeves is provided, the outside diameter of the bodies being turned to the inside finished diameters of the packing rings. Where the packing ring diameters vary between wide limits it may be desirable to build out for the larger sizes with concentric sleeves in order to avoid the heavy handling necessary if one sleeve only were used for each size of ring.

The mandrel is clamped to the boring mill table with four bolts through slots in the flange. Below the flange is an extension which fits the table spindle, thus insuring accurate centering with a minimum expenditure of time. With the sleeve in place on the mandrel, packing rings are applied until the last one projects from  $\frac{1}{16}$  in. to  $\frac{1}{8}$  in. above the top of the sleeve, the joints of adjacent rings being quartered. The band clamp *D*, details of which are shown, is then placed around the rings and they are drawn tight against the sleeve by turning the nut on the square threaded screw. Cap *C* is then secured in place and a number of  $\frac{1}{2}$ -in. set screws drawn down against the top ring. When these are tight the clamp may be removed and the outside of the rings turned. The shoulder at the lower end of the sleeve is  $\frac{1}{32}$  in. less in radius than the outside of the ring and provides tool clearance at the end of the cut.

After a chuck full of rings has been finished the set screws in cap *C* are slacked back, thus permitting the removal of the key, the cap and the finished rings, and the application of another set. From 70 to 90 rings can be turned per hour, depending on the size.

## ENGINEHOUSE METHODS\*

BY J. S. BREYER

Master Mechanic, Southern Railway, Charleston, S. C.

The successful handling of an engine terminal, be it large or of medium size, requires a man to oversee it who possesses very strong executive ability. He is daily dealing with all classes of men. Enginehouse foremen, as a rule, are drawn from the ranks of the machinists; however, this is not necessary, as I have known successful foremen who were boiler makers, carmen, machinist's helpers, and callers. It is very desirable that they have a fair working knowledge of all trades employed in railway shops, and a personality that will enable them to command the respect of everyone with whom they come in contact. With a man of this caliber in charge, and a corps of loyal and energetic sub-foremen, a volume of business can be handled so economically that it would surprise the average business man who is not conversant with railroad operation. To help in obtaining these results I would suggest that all enginehouse foremen read every issue of some good mechanical paper and the proceedings of the different conventions of the railway organizations, in addition to studying their force and facilities.

All enginehouse work, as far as possible, should be spe-

\*Entered in the competition which closed February 1.

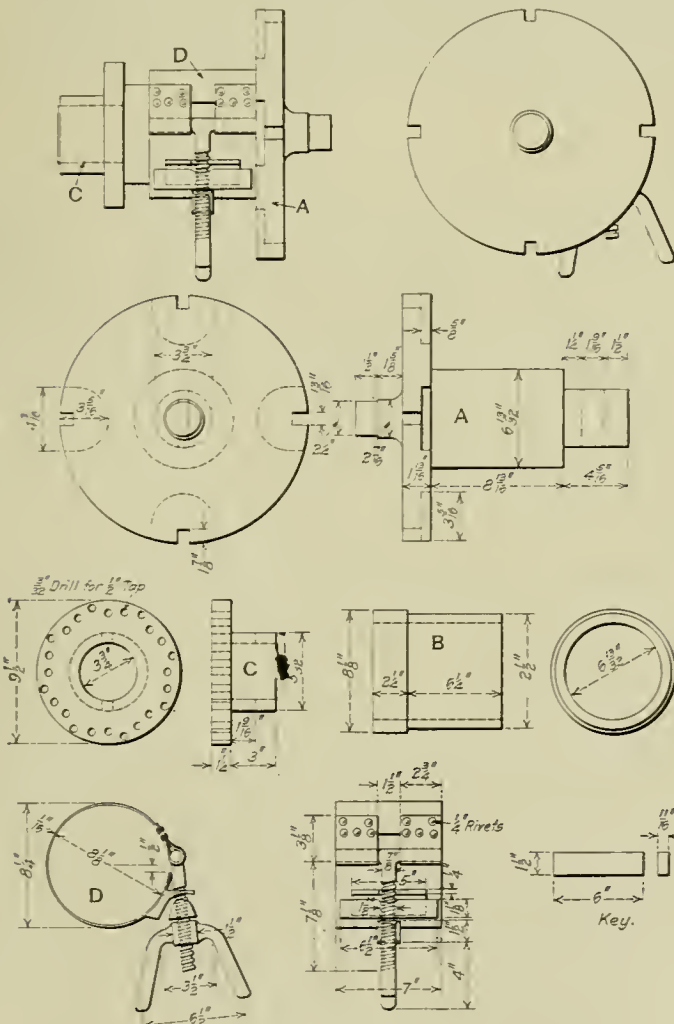

Jig for Finishing Air Pump Packing Rings

slightly out of round, thereby keeping the rings and cylinders to a perfect bearing at all times.

It is the practice of one railroad to rebore cylinders that are found to be  $\frac{1}{32}$  in. out of round, and to bush a cylinder when worn  $\frac{3}{16}$  in. larger than its nominal diameter. Rings are made to fit these rebored sizes, so it is necessary to have a chuck which is easily adjustable to turn rings with outside diameters increasing by steps of  $\frac{1}{32}$  in. This is accomplished by means of the chuck shown in the drawing, which

cialized; driving boxes, shoes and wedges, and rods and crosshead work should be cared for by the same men. Safety valves, steam gages, and cab valves should be taken care of by an assigned force of men, and so each group of work should be taken care of by the same group of men each day, and the men held responsible for the condition of that particular part of the engine. By so doing, the engines can be kept in service instead of in the back shop, and a great many engine failures prevented. It is sometimes difficult to make some men accept responsibility, but this is essential if it is expected to have a nearly perfect organization.

The expensive part of enginehouse organization lies in the unskilled labor, and here is where a foreman can bring about economical operation. Analyze your force of packers; you may find a man packing tank boxes and another driving boxes, and still another filling rod cups, perhaps each reporting to a different man. Put all of the packing together, and where there are four men now it will be possible to continue with three. Make a careful study of the hostlers' duties and the time when their services are required to prepare outgoing engines and meet arriving engines. Frequently you can dispense with the services of one man by changing the hours of another. If you work four hostlers you can get along with three, or if not all of the time, during certain seasons. Coal chute, sand house and cinder pit men can be worked in one group at a majority of medium-size engine terminals, thus reducing the cost of handling coal, and enginehouse expenses.

The sub-foremen should be constantly on the lookout for irregularities and keep the general enginehouse foreman in touch with them in order to make this department as efficient as possible. The foreman who puts forth his best efforts and works along these lines will not be forgotten when there is a chance for promotion. Such men do not need any advertising; even officers who have never seen them know their names. The transportation department is now paying more attention to getting engines from the trains to the enginehouse than they did a few years ago, but the matter should not be lost sight of, and hostlers should be impressed with the importance of the quick moving of engines to and from trains. The most important reasons for this are that the engine crews are being paid large sums of money every month for overtime; the engine is fired up and burning unnecessary coal which is one of the biggest items of expenses the railroad has; the engine is kept away from the enginehouse where perhaps every minute of its lay-over time is needed for inspection and repairs, and in a great many cases some high-priced mechanic is idle waiting for the hostler to move an engine for him, in order that he may put in a rod pin or some other part.

As soon as the engine arrives at the terminal and the fire is either banked or knocked out, the tubes should be cleaned. This should be done when the engine is warm. Cleaning tubes and washing boilers are very closely connected; each affects the coal pile if not properly done, and it will be found advantageous to work the men doing this work in groups and require the boiler foreman and shop foreman to personally follow up this work and see that it is properly done.

It is important to watch the orders from the transportation department. If engines are ordered and fired up and then not used, a report should be made to the proper officers. Thousands of tons of coal have been wasted due to engines being ordered and then the order cancelled. For the protection of the enginehouse force, three hours' time should be required to prepare an engine when it is ordered for a run not shown on the schedule. The order should be in writing, and, if taken over the telephone, it should be confirmed in writing.

## BABBITTING CROSSHEADS

BY H. C. GILLESPIE

Master Mechanic, Chesapeake & Ohio, Peru, Indiana

The accompanying drawing shows a jig which is used to babbitt the guide bearings of crossheads. It consists of a frame to the top of which is attached a crossbar and in the ends of which are provided V-bearings for the ends of the mandrel on which the crosshead is mounted. This is provided with a taper fit, the taper being the same as that of the crossheads, which facilitates mounting the latter and makes it only necessary to square the crossheads with the

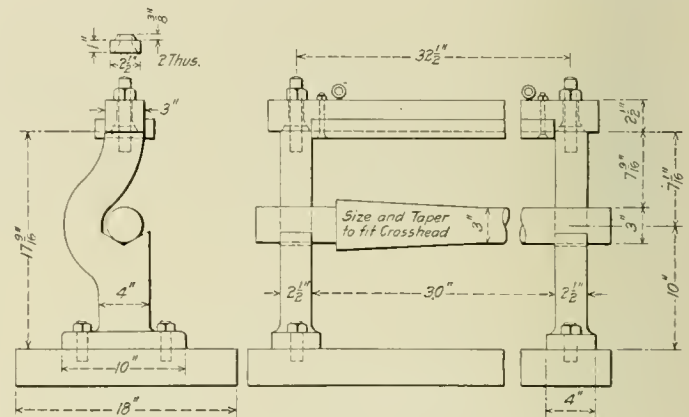

Mandrel and Jig for Babbitting Crossheads

base of the jig after the mandrel has been placed on its bearings. To the crossbar is attached a shoe which has been planed to the proper size for the guides of the engine class on which the work is being done. The height of the crossbar may be varied as required. By the use of this jig a crosshead can be finished ready for the engine in about one hour. It is ready for application as soon as the babbitting is done, no machine work being required.

## PREVENTION OF BOILER CORROSION BY ELECTRICITY

The method of preventing boiler corrosion, known as the Cumberland system, is being tried by the British Admiralty. This system is based on the electrolytic theory of corrosion and makes use of suitable iron plates placed within the boiler and insulated from it. These plates are connected to the positive terminal of a low tension generator, the boiler shell itself forming the negative terminal. The corrosion and pitting caused by local differences of potential between various points on the interior surfaces of the boiler is transferred to the anode plates by introducing a superior electro-motive force from an external source which insures that the flow of current is always from the inserted electrodes to the surfaces of the boiler. A potential of from six to ten volts is required and the current used is about one ampere for each 500 sq. ft. of surface to be protected. It will be seen that the action is similar to that of zinc placed within the boiler, but the iron anodes, used with an external source of current, do not require the frequent renewal which usually makes the use of zinc impractical.

A GLASGOW FORFEIT.—In a specification recently issued for a 6,000 k.w. turbine by the Glasgow Corporation, the following clause was inserted: "Should the contractor fail to meet the guaranteed steam consumption, the contractor shall pay to the corporation the sum of £750 for every quarter of a pound or part of a quarter of a pound consumed over and above the figure of guaranteed steam consumption per kilowatt-hour."—*Power*.



# THE MASTER BLACKSMITHS' CONVENTION

A Report of the Twenty-third Annual Meeting of  
the Association, Held in Chicago, August 15-17



THE twenty-third annual convention of the International Railroad Master Blacksmiths' Association was held at the Hotel Sherman, Chicago, Ill., August 15 to 17, 1916, T. E. Williams, of the Wabash Railroad, presiding. The meeting was opened with prayer by Reverend De Lacey, and the association was welcomed to the city by a representative of the mayor. Mr. Williams, in his presidential address, called attention to the desirability of all the members participating freely in the discussions and telling fully of their experiences in the various subjects discussed in order that the members of the association may profit to the fullest extent by the convention. W. J. Tollerton, general mechanical superintendent of the Chicago, Rock Island & Pacific, made an address of welcome.

#### ADDRESS OF MR. TOLLERTON

Associations, such as the Railroad Master Blacksmiths', are of the utmost importance. Upon you, gentlemen, falls the burden of advancing our knowledge concerning improved methods of blacksmith shop practice. By means of your various committee investigations and the discussions of the reports in conventions you, as members of this association, may interchange ideas with the privilege of choosing therefrom those which will tend toward a constantly increasing economy and efficiency in railroad operation. The blacksmith's art is probably the oldest metal working craft in existence, but during the long years of its practice very little real progress was made until about 60 years ago. One might truthfully say that the modern blacksmith shop came into existence with the invention of the steam hammer. Since then a wonderful advance has been made, until now we have forging machines capable of producing accurate and intricate forgings in a few minutes that formerly would have required hours of hard labor. I believe that the development of the forging machine and the perfection of machine made forgings is the line of future progress for the modern blacksmith. A very essential part of your work as an association consists in the interchange and publication of machine forging methods now in successful use on the many railway systems with which you are connected.

While reading the committee reports and various papers presented at past conventions the thought occurred to me that

it would be of enormous benefit to all railroads if this association would formulate some kind of a standardized schedule of blacksmith shop practice. As an example of what I mean, let us consider the process of case-hardening; with all the information we have on this subject, would it not be possible to arrive at some conclusion as to the exact procedure to be followed to give a case-hardened product of maximum value in railroad service? At the present time a great many methods are used. Different types of furnaces are used with a great variety of carbonizing mixtures and case-hardening temperatures are far from being fixed. Would it not be of great advantage to crystallize the opinion and experience of the members of this organization so as to arrive at a more definite and precise method of procedure, not only in connection with the matter of case-hardening, but all other methods of smith work that are under the direct jurisdiction of the members?

The present convention is assembled at a very serious period, and at a time when the need for economical methods and the conservation of material is more pronounced than at any other time in the history of this association. One of the most promising avenues for saving now open to the railroads is in the scrap dock. By means of the oxy-acetylene and electric welding processes the blacksmith is enabled to weld and repair a great many parts which he formerly was obliged to scrap. In the reclamation of material considerable study and the use of considerable judgment is of prime importance in determining to what extent we should go in replacing old material in service. The fact should not be lost sight of that many locomotive and car parts fail because they were not properly designed in the first place. It would be poor economy to reclaim such parts unless they could be reinforced or a change effected in the design, such that the original defect will be overcome. In all of this work an accurate determination of costs is of first importance, and this association will agree, I think, that cost-keeping methods in the average railroad blacksmith shop are open to improvement.

#### TUBE WELDING

George Massar, of the Cincinnati, New Orleans & Texas Pacific, presented a paper on this subject, in part, as follows: With the high pressures of steam which are now commonly

carried in the locomotive boiler, it is essential to provide good welds when safe ending boiler tubes. In the first place, the tube end and the safe end should be properly prepared. Second, a good furnace should be provided which will heat the tubes quickly and evenly, and, third, a good welding machine should be used and placed conveniently near the furnace. It is generally conceded that lap welds are stronger than butt welds. It is much easier to work a lap weld and to keep the tube straight. Also there is not the same danger with the lap weld that there would be in the butt weld if the weld should let go or pull apart. With the lap weld there would only be a small leak, for the lap would still hold the body of the tube in place, but when a butt weld fails, the body of the tube drops down and leaves the full area of the tube exposed, which is almost sure to cause serious injury.

Close attention should be paid to the proper scarfing of both the safe end and the tube end. A sharp short lap of from  $\frac{1}{2}$  in. to  $\frac{5}{8}$  in. is advisable on small tubes. When the joint is prepared in this way the place at which the weld is made will not be much thicker than the gage of the tube and it will heat evenly. Where the tubes are not scarfed there is a double thickness of metal to heat, and there is a tendency to overheat and burn the tube just back of the joint, particularly with steel tubes. There should be a proper plan adopted for scarfing the tubes and the safe ends so that the metal of the body of the tubes and the safe ends fit closely together. Care should be taken to keep the heating port in the oil furnaces, which are now commonly used for tube welding, narrow so as to concentrate the heat on the weld. If this is neglected and the opening is too broad the safe end will be overheated on the tube sheet end where it has to stand the rolling, beading and prossering. The mandrels on the welding machine should be kept well up to size. On small locomotive tubes the welding and swedging should be done at the same heat and thus eliminate the cost of a reheating.

All superheater flues should be welded at one heat. It is a very simple matter to do this by getting the proper heat on the flue, which can be done by watching the heat inside of the flue. The bumper should be removed from the back of the furnace, and the heater stand at the back and hold the safe end in place with tongs until it shows signs of the welding heat. The safe end should then be given a few light taps with a hand bumper until it is well set in the flue. When the metal on the inside shows that it has been heated to the proper temperature the flue with the safe end should be placed in the welding machine and welded.

Good heating is the most important part of tube welding. No matter how well a tube is scarfed and prepared, or what type of welding machine is used, or in how perfect a condition the welding machine is kept, results cannot be obtained unless the metal is properly heated. Overheating of the metal causes more accidents than underheating, for in the first case it will break off abruptly and allow the tube to drop, giving a full opening for the escaping water and steam.

L. R. Porter of the Illinois Central also presented a report on this subject, stating in part, as follows: The flue welding work on the Illinois Central is done by the boiler shop forces. The tubes are trucked from the erecting to the boiler shop, where they are run through an Otto rotary machine and then

passed to the cutting machine. One man handles the two machines. He cuts off one tube while the other is cleaning. One man applies the safe ends, sticking them on, welding them and swedging them, averaging about 22 tubes per hour. The tube is swedged and welded with a Draper pneumatic hammer. The superheater flues are swedged in the smithshop under a Beaudry No. 7 power hammer. In this hammer dies are used, but no mandrel of any kind. The work is done with very good success. Two men will swedge 12 tubes per hour and carry them in and out of the shops, as the room is limited and they cannot be piled inside.

#### FRAME MAKING AND REPAIRING

G. A. Hartline of the New York Central West presented a paper on this subject, from which the following is taken: The portable system of repairing locomotive frames in position on engines has largely solved the problem of doing this class of work in roundhouses or machine shops where no other facilities are at hand. One of the most essential features in making the different kinds of welds is to have a clean surface at the point where the weld is made. Great care should be taken to avoid all strain in cooling, as the frame is liable to break in some other location. In our shop we use the oil furnace and the electric processes of welding. Fig. 1 shows an oil weld made on a passenger engine. The upper and lower rails were welded at the same time. Enough of the fracture was cut away to leave both ends square. A block was finished all around on the inside to make a good fit between the rails of the frame. After the frame had been jacked apart three-quarters of an inch the block was inserted and caulked with an air hammer all around to keep out any dirt or scale that might accumulate at this point. A brick furnace was built around the frame with a two-inch clearance. The burners were located on either side of the frame and the frame brought to a welding heat. A few of the bricks were then removed and the frames rammed on both sides, after which the bricks were replaced and the frame allowed to cool off. This frame was

welded the latter part of December, 1914, and is still in service.

Fig. 2 shows the method of welding a locomotive frame by the electric process. The fracture was cut away to an angle of 45 deg., and the opening filled in to the full size of the frame. It was then reinforced, as shown in the illustration, with strips of  $\frac{5}{8}$ -in. round cold-rolled steel on the bottom and sides, this steel being welded into place directly over the crack. The top and inside of the frame could not be treated in this manner on account of a heavy cross brace that was located at this point.

The following is from a paper on this subject by P. T. Lavender of the Norfolk & Western: In making or repairing locomotive frames the first essential is having the necessary facilities to handle the heavy frames which are constantly increasing in weight. The blacksmith should have at all times sufficient experienced help so that the job can be properly and quickly done. Welding frames with Thermit, oil or by the electric process, has proved satisfactory where the repairs to be made are of a light nature and when the engine is being rushed back into service. In repairing with the elec-



T. E. Williams, President,  
Master Blacksmiths' Association

tric process the frames are prepared in a manner similar to that used when they are welded on the anvil. The break is V-ed out with an oxy-acetylene torch and then welded up by the electric process. When an engine comes in for heavy repairs and the frames are in bad condition they are brought to the smithshop and welded on the fire.

DISCUSSION

The discussion of this subject was quite extended, and those who came from shops at which either the electric



W. C. Scofield, Vice-Pres.,  
Master Blacksmiths' Association

or oxy-acetylene methods were extensively used reported that excellent results had been obtained by both these processes. It was pointed out, however, that expert men must be chosen to do the work. On the Frisco it was stated that the oxy-acetylene welded frame is a greater success than a frame weld made by any other method. Three-sixteenths of an inch is allowed for expansion, and the work is done in one heat; that is, the weld is not allowed

to cool from the time it is first started. Two men work on the frame at the same time, one on either side. If the job is a long one they are relieved by two others, who are ready at all times to pick up the work without allowing the frame to cool. J. Grimes stated that on the New York Central, of over 300 welds made by the electric welding process only four per cent were failures. The breaks in the frames were V-ed out and welded, the section being increased in size.

The manner in which the frames were cast was also spoken of. H. D. Wright, of the Big Four, called attention to the fact that the thicker portions of the frame were found to fail many times sooner than the section of lesser cross section. He believed that this was due to the fact that as the frame was cast the smaller section cooling first created strains on the thicker section, decreasing the density of metal in that locality and causing weak spots. He stated that this could be obviated by placing risers at the heavy portions when the castings were made and adding more metal to these risers as the shrinkage of the smaller section pulls the metal away from the thicker section. Where this was done it has been found that the frames do not break as readily as where it is not done. It was also pointed out that sharp corners had many times been found to be responsible for cracks occurring in the frames.

John Carruthers, of the Duluth, Missabe & Northern, also called attention to the severe strains set up in pedestal jaws when the shoes and wedges were not kept up in proper condition and when the rods were allowed to pound. Poor track is a very active source in causing frame breakages. He suggested that a committee be appointed to report at the next convention on the best practice of welding locomotive frames, in accordance with the ideas suggested by Mr. Tollerton in his address.

Repairing the frames on the locomotives in preference to taking them to the smithshop and making an ordinary smith fire weld was believed by Mr. Grimes, of the New York Central, to be the most practical way. In the shops at Cleveland the welds are made on the engine in preference to making them in the smithshop. This is carried to the extent of

placing new front end sections on frames with the frames on the engines. T. E. Williams explained the methods being used by the Wabash Railroad, of welding frames which had cracked in the upper rail at the corner of the pedestal jaw. The break is V-ed out and two wedges, machined to fit in the V's, are bolted to the break and welded by the oil torch method, one torch being on either side of the engine.

DROP FORGING

H. E. Gamble, of the Pennsylvania Railroad, presented a paper on this subject, in part, as follows: In drop forge work, if the dies and trimmers do not have the proper treatment and are not made from good steel they will not last. Carelessness in making them will cause many delays and also much expense. It is also bad practice to overtax any hammer. The expense in replacing rods, dies and anvil blocks would more than pay for the purchase of a hammer of larger capacity. In the Juniata shops of the Pennsylvania Railroad, the Chambersburg, the Erie and the Morgan hammers are used. The steels used for the dies are Colonial, Carpenter, Sanderson, Vanadium cast-steel, Hardtem, Chrome Vanadium (S grade), Park alloy, Mayari, Adamite and 45-point carbon well hammered bloom steel. For hot trimming we use axle steel, bloom steel, crescent hot work No. 2 Peerless A, Firth-Sterling, Colonial and Sanderson No. 3 to 3½ temper. We make out of the scrap iron or steel all of the large forgings that can possibly be made. The extra cost for roughing dies and preparing the metal for the forming dies should be carefully considered, as it all means time and money and also reduces the output of the hammer.

The first question to arise when the dies or trimmers are being designed is how much strength is required to withstand the working conditions. That material should be used, the grade and carbon content of which will admit of its being treated so that the longest wearing surface can be obtained in conjunction with sufficient strength to resist the working conditions. We must have a sufficient working knowledge of the critical points of the steel or the nature of the mineralogical changes in the steel when it is heated in order properly to prepare the dies and trimmers. Keep the tools and furnaces

up in good condition, as the time spent in fooling around with an old tumble-down furnace will cost more than if money were spent for a good furnace.

Good steel for dies may be found in the following three brands: Sterling, Mayari and Hardtem. This material is forged in suitable blocks for drop forge work and is a special alloy steel treated before leaving the mill, so that it is not necessary to harden it.



J. Carruthers, Vice-Pres.,  
Master Blacksmiths' Association

After the impression is worn out it is not necessary to anneal this steel; simply plane and resink the die and it is ready for use. A good steel for piston rods is the Heppenstall, which is treated at the mill and delivered rough-turned. This gives excellent service.

Unless everything connected with the drop hammer is properly handled by the operator you are bound to have broken dies and piston rods. Sediment under the section blocks and dies not properly treated and keyed up will give bad results. Make the tongue on the dies of good width to insure a good bear-

ing on the section block, it saves liners and keys. Always have the guides adjusted and oiled regularly. The operator must examine the many parts of the drop hammer regularly. It will be found that a regular and systematic examination will overcome many an accident. Use plenty of lubricant when necessary, in order to insure good service.

### TOOLS AND FORMERS

George Fraser, of the Atchison, Topeka & Santa Fe, presented a paper on this subject, in part, as follows: There is no place about a railroad shop where such a saving can be made, provided the shop has good tool equipment, as in the blacksmith shop. Good shop organization and a first-class supply of good tools of all kinds are necessary to increase the output and reduce the cost in the smithshop. In the Topeka shops we have about 1,500 dies and formers of all kinds. Fig. 3 shows the dies used for forming the ends of spring hangers on a 4-in. forging machine and at the same time producing a fillet at *A* without checks, flaws or scarfs. The back stop is set so that the edge *B* on the boss of the hanger is 1 in. from *C* in the dies. The back stop has a spring block, as shown in the illustration, which is forced closed as the header forms the end of the hanger. The header is provided with a groove  $\frac{3}{16}$  in. wide and  $\frac{1}{8}$  in. deep to overcome the seam in the center of the boss.

Fig. 4 shows a method of reclaiming car axles. The scrapped 5-in. by 9-in. axles are made over into  $4\frac{1}{4}$ -in. by 8-in. axles, the  $4\frac{1}{4}$ -in. by 8-in. into  $3\frac{3}{4}$ -in. by 7-in., etc., by the following method: The axle is heated and is made to the correct length at *A*. At the same time the collar on the end of the axle is swedged down to the size of the journal. The axle is then annealed. The ends are heated and forged in a forging machine the dies for which are shown in Fig. 4. The dimensions *AA* of the dies are  $\frac{1}{8}$  in. larger than the axle, the dimension *B* is 1 in. shorter than the finished length, *C* is  $\frac{1}{2}$  in. larger, *D* is  $\frac{1}{4}$  in. larger, and *E* is  $\frac{1}{4}$  in. shorter than the finished sizes to allow for machining. The plunger upsets the end of the axles and centers them at the same time. Up to the present time over 5,000 axles have been thus reclaimed on the Santa Fe system.

### SPRING MAKING AND REPAIRING

The following is from a paper by W. C. Scofield, of the Illinois Central, on this subject: Many roads are discontinuing tapering the ends of the spring leaves as an unnecessary expense, but it does not make as nice a looking spring. It is the practice on the Illinois Central to fit and cool the springs in an oil bath at the same heat. The open hearth spring steel over  $\frac{5}{16}$  in. thick is not flashed, but left as it comes from the oil. It is very important that the heat in a fitter's furnace be regulated properly and easily controlled, as a uniform heat is absolutely essential in making good springs. The best method of fitting is to use a machine that sets each leaf to leaf by air or hydraulic pressure and one which operates quickly. The steel must be of uniform grade and quality, as it is self-evident that where different kinds of steel are used in the same spring, all being heated and treated the same, the spring will not give the proper results. In repairing springs, if the leaves are not broken or

worn too much and are of the proper set, they are not overheated or re-fitted, but are placed in the spring as required. Vanadium steel springs are being used by many roads, which report excellent results.

### DISCUSSION

Some of the members have found difficulty in repairing the springs on account of not being furnished with the same material from which the original springs were made. This was generally conceded to be very bad practice. Numerous instances were mentioned where the original springs had not been found to be of sufficient capacity, and it was believed advisable for the blacksmith to be sufficiently familiar with the weights of the engines for which they are called upon to repair springs, in order that they may determine for their own satisfaction whether or not the springs were too light for the service in which they were used, and in this way protect themselves from criticism of their work.



George P. White, Asst. Sec.-Treas.,  
Master Blacksmiths' Association

It was believed to be poor practice to use the broken leaves for the leaves of shorter length, and on some roads the leaves are scrapped after they have been reset four times. A number of the roads are not tapering the ends of the spring leaves, believing this to be a waste of time and money. It was also believed by a large number that it was not necessary to cool the bands when they were put on at a dark red heat as this heat would not draw the temper enough to do any harm, whereas if the bands are dipped the leaves are apt to become too hard. J. W. Riley, of the Lehigh Valley, contributed a layout of the spring plant of that road at the Sayre, Pa., shops, which is shown in Fig. 5.

### CARBON AND HIGH-SPEED STEEL

George W. Kelly, of the Central Railroad of New Jersey, presented a paper on this subject, in part, as follows: The forging of carbon steel always requires skilled workmen, especially for the larger tools, such as taps, reamers, etc. Carbon steel should be hardened at the lowest possible heat, and always on a rising heat. Steel may be forged at a higher heat than the hardening heat, but should, in all cases where a large or expensive tool is being forged, be annealed before being heated for hardening. We are welding tips on tire steel for all lathe tools by the electric welding process and obtaining very good results. When the 6-in. by 10-in. special milling cutters are worn down they are box annealed, recut and hardened, as follows: They are first preheated in an oil furnace up to 1,400 deg. F. They are then passed to a specially prepared hollow fire and heated to 2,000 deg. F. The cutting edges are protected by powdered borax. The cutter is then dipped into a cask of melted lead. Running water is allowed to circulate around this cask. When the lead is set it is reheated and the tool taken out and cooled in oil. The tire-forming tools are hardened in the same manner. It has been found that this gives very good service with no breakage.

J. J. Connors, of the Atlanta & West Point, also presented a paper on this subject, of which the following is an extract: During the past two years we have been welding high-speed steel on axle steel shanks by the oxy-acetylene method, and



A. L. Woodworth, Sec.-Treas.,  
Master Blacksmiths' Association

in this way use up the small pieces of high-speed steel tools. In annealing the high-speed steel it is heated to a red heat and placed in an iron box or pipe and covered with pulverized charcoal, put in the furnace over night and removed the next morning, but the box is not opened until it is thoroughly cooled. In hardening the high-speed steel lathe and planer tools, they are heated to a high heat sufficient to just about burn the point of the tool and are then cooled in a fan blast

the high-speed steel tip and the shanks. It has been found possible to forge these tools to any desired shape, and to re-dress them until the high-speed steel has been entirely worn off. The tire turning tools have met with very good success, one tool having turned 214 tires.

Several members stated that while they had found it possible to weld high-speed steel on tire steel shanks, it had been found impossible to forge the tools for the tips would invariably come off. In many cases it was only possible to re-dress the tools once, and then but a few blows of the hammer must be used. Mr. Harris, of the Missouri, Kansas & Texas, Parsons, Kan., stated that high-speed steel tips are welded on carbon steel shanks, as follows: The shanks are heated and the flux compound applied. The cold tip is then placed on the shank and the whole reheated. The tool is then formed in a forging machine.

There was considerable discussion in regard to annealing high-speed steel, some claiming that the use of charcoal in this process would injure the steel. However, it was pointed out that if the steel was properly protected from the air no trouble would be experienced with properly annealing this

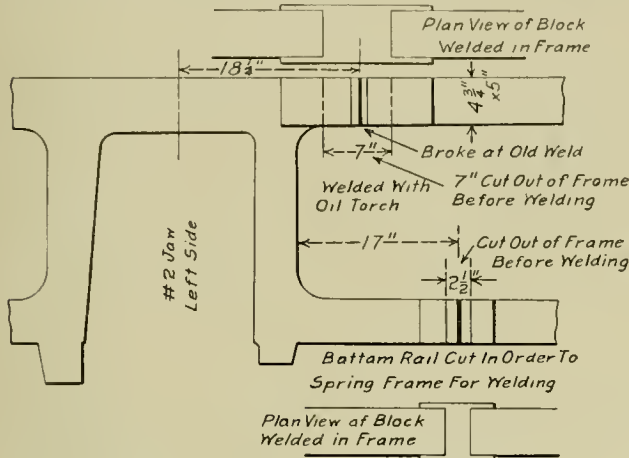

Fig. 1—Location of Oil Weld on Frame of Passenger Locomotive

The taps or reamers made of high-speed steel are hardened in oil.

D. M. Dulin, of the Norfolk & Western, also presented a paper, in part, as follows: We have been welding high-speed steel tips on carbon steel shanks by the electric butt welding process. The tools to be welded have the surfaces ground bright and are clamped in the vise, and the current applied. A vise screw is operated to press the two metals together as the temperature increases. The power required to

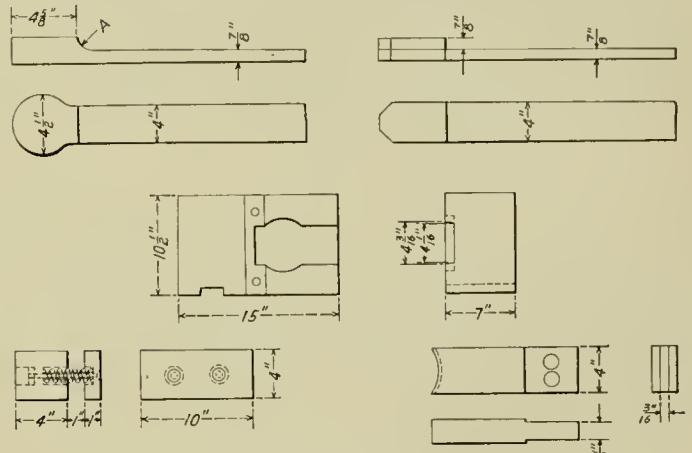

Fig. 3—Dies for Forming Spring Hanger Ends

operate the machine is from 1/2 to 5 volts, and 8,000 to 16,000 amperes. We weld tools from the smallest size up to 2 in. by 3 in., with good success. The tools are dressed after welding and are hardened in an air blast or oil, as preferred.

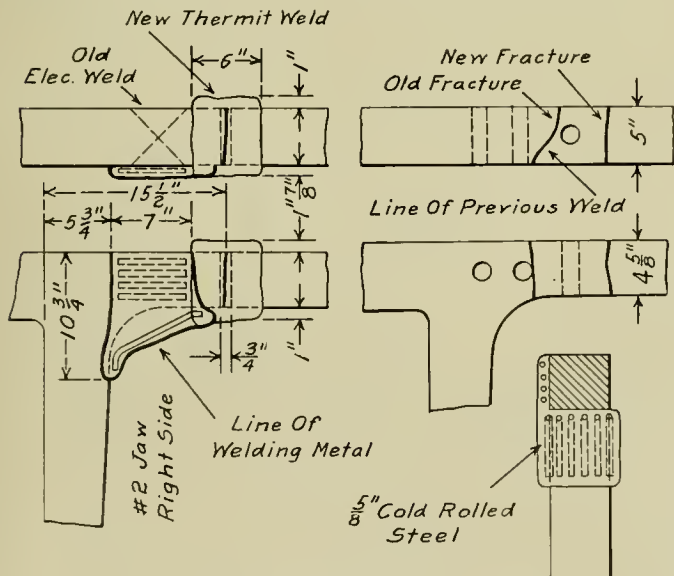

Fig. 2—Cast Steel Frame Thermit Weld

operate the machine is from 1/2 to 5 volts, and 8,000 to 16,000 amperes. We weld tools from the smallest size up to 2 in. by 3 in., with good success. The tools are dressed after welding and are hardened in an air blast or oil, as preferred.

DISCUSSION

George W. Grady, of the Chicago & North Western, stated that at the Chicago shops of that road high-speed steel tips have been welded on tire steel shanks by the oxy-acetylene method, tire steel being used for the metal to fill in between

grade of steel, regardless of the kind of packing material used.

FROGS AND CROSSINGS

George T. White, of the Missouri, Kansas & Texas, presented a paper on this subject, saying, in part, as follows: At the Parson shops of the Missouri, Kansas & Texas we manufacture 150 rigid frogs per month, and repair 30 spring frogs per month, in addition to other various items, such as guard rails and reinforced switch points. In making repairs to frogs and switches our Oxweld plant plays a very important part. We have several switch points which were built up by the Oxweld system that have been in service six or eight months and are good for several months to come. This is about the length of service we get from most new points on this line. This road also operates a repair car fully equipped for making light repairs to frogs and crossings on the road. Three men, who accompany the car, make the light repairs wherever they may be necessary, and where they can be made without removing the frog from the track. This car is sent over the entire road. The road's repair gang keeps the shops at Parsons advised as to when the frogs will need to be replaced. This gives the shops time to build the frogs for any given place.

D. Huskey also read a paper describing briefly the new frog and switch plant of the Chicago Great Western at Oelwein, Iowa.

DISCUSSION.

Mr. White stated further that repairs to a switch point by the Oxweld method cost an average of \$1.25 each, and re-

pairs to a spring frog cost an average of \$2. Some, however, will run as high as \$4 or \$5. It has been found on the Missouri, Kansas & Texas that this class of repairs will give practically the same life as a new point. However, it was stated that the Frisco did not find this to be the case. On that road it is the practice to raise the point by splitting the web and then fill in the web by the Oxweld method, thus using the original material on the point. The use of manganese rail for all frogs and crossings was strongly recommended.

**PIECE WORK**

H. D. Wright, of the Cleveland, Cincinnati, Chicago & St. Louis, presented a paper on this subject, in part, as follows: A proper piece work system is one that will be bene-

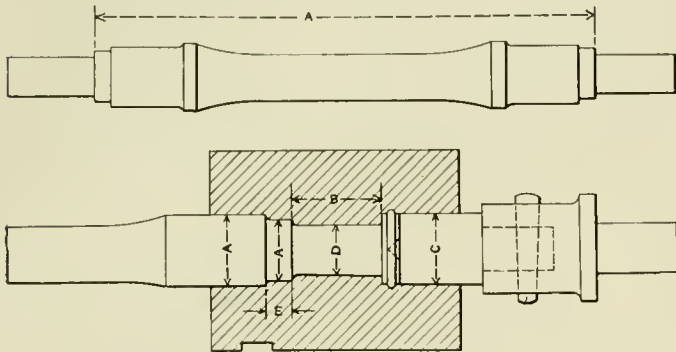

Fig. 4—Dies for Reclaiming Car Axles

ficial for both the company and the employee, but there must be some well-defined system of making the prices, checking the work and figuring the cost so as to divide the money justly. Piece work will develop the mechanic and will eliminate the sluggard. It brings out the best the mechanic has in him, for he knows that he will be paid for the results of his efforts, and he will not hesitate to show his ability. In gangs it has

tailed instruction regarding the application of piece work on this account.

**RECLAMATION OF SCRAP**

J. Harkins, of the Southern Pacific, presented a paper on this subject, from which the following is taken: There is no department in connection with a railroad that should be given more attention than the reclaiming department. This is particularly true at the present time when all classes of material used in railway equipment have advanced in price from 10 to 50 per cent, and in some cases even more. The following is a list of tools used in a reclaiming plant, one or more being used according to the amount of work being done: Oil forge, oil furnace, steam hammer, power hammer, shears, bulldozer, power punches, forging machine, straightening press, nut tapping and bolt threading machine.

The following are a few of the many articles being reclaimed at the Southern Pacific shops at Sacramento in which large savings have been made for the company: Handholds, king pins, coupler pins, coupler yokes, coupler plates, carry-irons, brake rods of all kinds, brakeheads, brakeshoe keys, brake levers, brake staffs, brake staff hand wheels and brackets, uncoupling levers, door clamps, door straps and fulcrums, turnbuckles, running board brackets, brakebeams, sill steps, old bolts, nuts, washers, etc. We also reclaim all track material that can be made serviceable, such as frogs, crossings, switch points, connecting rods, track picks, tamping bars, claw bars, chisels, wrenches, mauls, gages, lining bars, etc.

There are also many articles that can be made from scrap and obsolete material as a substitute for new material. Old boiler tubes when flattened can be used for making car door plates, washers, split keys, pipe hanger clamps, angle irons, etc. Coil springs of various sizes, after having been straightened, are used for making lining bars, drift pins, etc., and can also be rolled into smaller sizes and used for making new springs. Thirty-ton car axles are made from scrap 40-ton axles, and 40-ton are made from 50-ton axles, this being

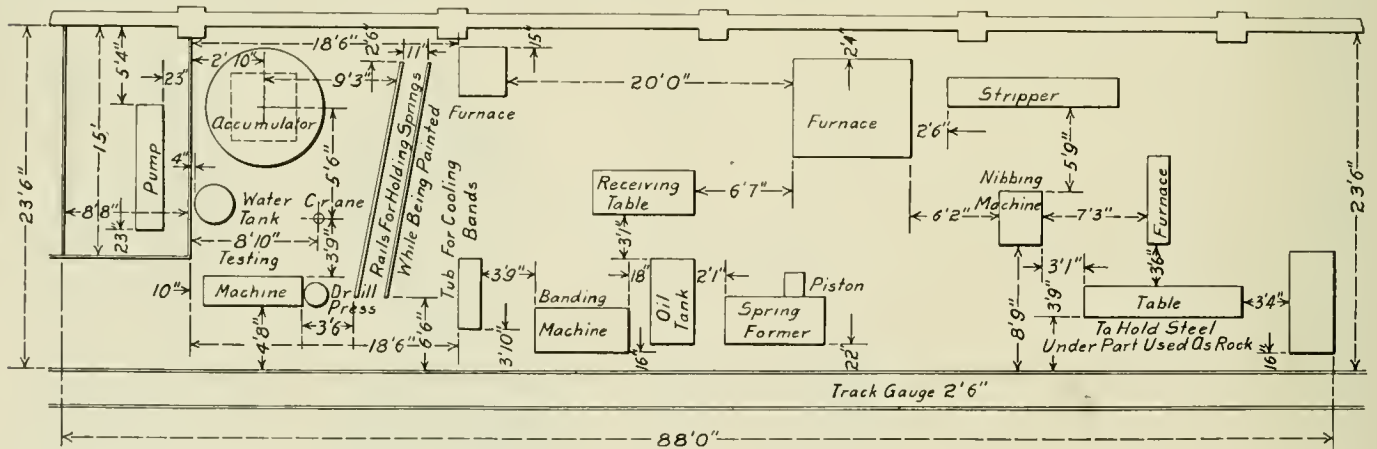

FIG. 5—Plan of the Spring Plant of the Lehigh Valley at Sayre, Pa.

a very beneficial effect. The men will work together with much more team work and they will turn out a larger amount of work.

First-class mechanics should be chosen for piece work inspectors. They should be thoroughly competent to make a price that will be just and also be able to show the men how the work can be done under the price set so that they will be able to make a profit. Where piece work is used the foremen must study their men and see that they are placed on the class of work to which they are best adapted. This will not only benefit the company, but the men as well. Conditions will vary in different shops, and it is hard to give much de-

done by upsetting the collars and drawing the axles to the proper length.

Scrap tire steel can also be used for making standard track claw bars, pick points, tamping bar ends, headers and dies for bolt forging machines and shanks for lathe and planer tools of various sizes. These tire steel shanks with high-speed steel tips are giving very good service. At our shops we endeavor to reclaim all serviceable material. The remainder is sheared to length and turned over to the rolling mill, where it is rerolled into all standard sizes of bar iron. This iron is then shipped to outside points on the line. The average monthly reclamation in this mill is about 4,350,750 lb.

J. H. Daltry, of the Erie, also presented a paper on this subject, of which the following is a part: Lathe tools are made out of scrap tires with high-speed steel tips welded on by the electric process at a cost of about 10 cents per tool. They are giving very good results. Worn coupler knuckles are reclaimed by welding on a piece of  $\frac{3}{8}$  in. by 2 in. iron where the knuckle is worn. The cost of labor for this is 15 cents a piece for all classes of knuckles and about one pound of wrought iron is used. The reclaimed knuckle is practically as good as new. The side ladders on box cars are made from scrap boiler tubes flattened out under the steam hammer, for which \$1 per 100 is paid. This is used in place of the  $\frac{3}{8}$  in. by 2 in. iron which is generally used for this purpose. Tube beading tools are also made out of tire steel and are doing the work just as well as those tools made from tool steel. All the hexagon-headed bolts removed from locomotives when undergoing repairs are annealed and turned down to a smaller size and used again. All of the blacksmith tools, except chisels, are made from scrap tire steel. Boiler and machinist hand tools are made of scrap coil springs and are giving very good results.

#### TOPICAL DISCUSSIONS

*Oxy-Acetylene and Electric Welding.*—It was believed to be the best practice to have all welding, whether done by either the oxy-acetylene or electric welding process, under the jurisdiction of the blacksmith. This plan is followed on the Frisco. On that road a blacksmith is the foreman of the welders, no matter what class of work is being done. It has been found that a blacksmith, in view of his experience in the heating of metals, is better able to make the proper allowance for shrinkage than any other craftsman. On this road the Oxweld system is used very extensively for reclaiming and repairing a large assortment of material.

A method followed in welding frames was described by one member as follows: The frame each side of the break is covered with an asbestos plaster in order to prevent undue heating of the frame on either side of the break. A fire brick is laid across the top of the plaster above the break to concentrate the heat in the weld. An air jet from a vertical pipe about 3 ft. long, perforated with  $\frac{3}{16}$  in. holes, is so located as to blow the heat away from the operators as much as possible. The frame is not pre-heated before welding, and during the process of welding the metal fused into the break is frequently hammered with an air hammer.

*Case-Hardening.*—The hydro-carbonate of bone black seems to produce the best results in case-hardening. For quick work a mixture of 14 lb. of potash to 50 lb. of salt, melted in a crucible and brought up to a temperature of 1,800 deg., was strongly recommended. However, the price of potash is so great at the present time that this method is almost too expensive to be considered. Questions were asked regarding methods by which the case hardening could be done in a short period of time, but it was generally believed that if any material is to be case-hardened to the proper thickness it must be given sufficient time and that no short-cut methods were available. Material can, however, be case-hardened in a minimum amount of time if the material is placed in the furnace in small quantities, as it will take less time to bring the material up to the proper temperature. Some questioned the advisability of carrying the case-hardening deeper than  $\frac{1}{16}$  in., but it was pointed out that if it was only carried this deep the outer surface would not be as hard nor contain as large an amount of carbon as if the case-hardening was allowed to penetrate to  $\frac{1}{8}$  in. With the  $\frac{1}{8}$  in. case-hardening the material would give much better service and wear for a longer time. The question was also raised as to whether or not the inside of the case-hardening box was not hotter than the furnace itself. It was explained that that would be dependent on the material used for doing the

case-hardening. Pure charcoal would undoubtedly show higher temperatures inside the case-hardening box than the furnace would show. However, if the material was of an inert nature the temperature would not rise.

*Heat Treatment of Metals.*—H. E. Gamble, of the Pennsylvania Railroad, gave a brief talk on the heat-treatment of metals, referring to his rather extensive paper on the subject printed in previous proceedings. He stated that the steel should be heat-treated according to its carbon content. The steel should be analyzed before being treated to find out just what its percentage of carbon is. The smaller articles are heat-treated in oil and the larger ones in water. The success of heat-treating is dependent to a very large extent on the facilities for doing the work. In annealing rods it was stated to be bad practice to anneal one end of the rod at a time. The entire rod should be heated and annealed at once.

In replying to a question as to the adjustment of the length of a heat-treated side rod on the smith fire, Mr. Hutton, of the New York Central, stated that if the heat used in making this adjustment was at a temperature lower than that used in treating the rod the heat treatment would not be affected. On the other hand, if the heat used in adjusting the rod was greater than that used in treating it, it would be necessary to reheat-treat the entire rod. Attention was called to the articles on the heat-treating of steel in the *Railway Mechanical Engineer* for July and August, and it was voted to have these articles reproduced in the proceedings.

#### OTHER BUSINESS

A paper was also read on the use of powdered coal as fuel for blacksmith shops, by C. F. Herington, mechanical engineer of the Bonnot Company, Canton, Ohio. This paper is abstracted elsewhere in this issue. The following officers were elected for the coming year: President, W. C. Scofield, foreman blacksmith, Illinois Central, Chicago, Ill.; first vice-president, John Carruthers, foreman blacksmith, Duluth, Missabe & Northern, Proctor, Minn.; second vice-president, George T. White, foreman blacksmith, Missouri, Kansas & Texas, Parsons, Kan.; secretary-treasurer, A. L. Woodworth, Lima, Ohio. The secretary reported a total membership of 237. Chicago received the largest vote for the next place of meeting.

#### ENGINEHOUSE ORGANIZATION\*

BY C. C. LEECH

The large body of men required to successfully and efficiently operate a large enginehouse may perhaps be best managed by dividing them into four groups or divisions, each under the supervision of an assistant foreman who has been specially trained and selected for his peculiar fitness for the work to be performed by his group. The arrangement of these groups or divisions will, of course, vary somewhat with the conditions, and while the force should be amply large to meet the heaviest strain, it must not be top heavy, or include any dead wood. But it is usually found that the force is never any too large whether in busy times or slack.

The following is suggested as a practical arrangement of the groups, and has worked out satisfactorily:

Group 1.—Made up of machinists, helpers, pipe fitters and engine inspectors.

Group 2.—Made up of boiler makers and helpers, the boiler washing, boiler testing and staybolt testing gangs, staybolt inspectors, tube cleaners and firing up men.

Group 3.—Made up of laborers, sweepers, house cleaning gang, and the engine wipers and cleaners.

Group 4.—Made up of the hostlers and engine caretakers, the ashpit gang, coaling men, engine dispatchers, callers and the turntable men.

\*Entered in the Engine Terminal Competition.



Tool Room of the Chicago, Great Western at Oelwein, Ia.

THE eighth annual convention of the American Railway Tool Foremen's Association was held at the Hotel Sherman, Chicago, Ill., August 24 to 26 inclusive, J. J. Sheehan, tool foreman of the Norfolk & Western, presiding. Prayer was offered by Bishop Thomas Nicholson, and the convention was welcomed to the city by John D. Shoop, superintendent of Chicago schools. J. A. Carney, superintendent of shops of the Chicago, Burlington & Quincy at Aurora, addressed the convention. President Sheehan in his address of welcome said:

You have been called from your various roads for the purpose of reviewing the progress that has attended our efforts during the past year, as will be shown by the committee reports, and to gain new ideas from them and the discussions on the floor of the convention. That our association has filled its niche in the railroad field is evidenced by the many favorable comments and references that have come to my notice. This is gratifying, inasmuch as it proves there is a need for the work in which we are engaged and it should stimulate us to put our earnest efforts into that which we undertake. The association is in a healthy condition, both financially and in regard to increased membership.

#### HEAT TREATMENT OF STEEL

Henry Otto, A. T. & S. F.: Whether annealing, hardening or tempering, each grade of steel has a definite temperature to which it should be heated in order that it will give the best results. This temperature will also vary according to the use to which the steel is to be put. Slight variations from this proper temperature may do irreparable damage to the steel.

*Carbon Steel.*—Carbon steel when not heated above 1,350 deg. will be in the annealed state and when heated to 1,350 to 1,500 deg. will be in a hardened state. When heated above 1,500 deg. it will be softer than the second case mentioned, although harder than the first. In the actual heating of a piece of steel several requirements are essential in order to obtain good hardening; first, the small projections or the

cutting edges should not be heated more rapidly than is the body of the tool, and second, all parts of the tool should be heated to the same temperature. A tool heated uniformly to as low a temperature as will give the required hardness will produce the best results. As steel is heated there is a certain period during which the internal structure of the steel changes. This is called the "critical point" and will vary according to the amount of carbon contained in the steel. With the steel used at the Topeka shops of the Santa Fe for making reamers, taps, etc., this change commences at 1,280 deg. called the recalescence point and ceases at 1,385 deg. which is called the decalescence point. The decalescence point is the proper temperature for hardening and the recalescence point is the proper temperature for annealing.

We heat all the tools made of carbon steel in lead pots, the temperature of which is recorded by pyrometers and maintained at the proper degree. To prevent the hot lead from sticking to the tool heated in it, the tool is painted with a mixture of common whiting and wood alcohol. These lead melting pots are made from 6 in. iron pipe and are reinforced with  $\frac{3}{4}$  in. by 4 in. iron rings, the bottom being welded in. They will last when used every day for about three or four months. All tools made of carbon steel are quenched in pure water in a tank shown in Fig. 1.

For tempering by the color method temperatures corresponding to the different colors are given below:

Color.	Deg. Fahrenheit	Color.	Deg. Fahrenheit
Very pale yellow.....	430	Spotted red brown.....	510
Light yellow .....	440	A brown purple.....	520
Pale straw yellow.....	450	Light purple .....	530
Straw yellow .....	460	Full purple .....	540
Deep straw yellow.....	470	Dark purple .....	550
Dark yellow .....	480	Full blue .....	560
Yellow brown .....	490	Dark blue .....	570
Brown yellow .....	500		

The modern method of tempering is to heat the tools to the required temperature in a bath of molten lead, heated



oil or other liquids. By this method it is possible to heat the work uniformly and to give a temperature close to the proper limit. At Topeka we use an electrically heated oil bath for tempering all carbon steel tools.

**High Speed Steel.**—Temperatures of from 1,800 to 2,200 deg. are required to harden high speed steel. The usual method of hardening or heat treating planing tools is to heat the cutting end slowly to a temperature of about 1,800 deg. and then more rapidly to 2,200 deg. or until the end is at a dazzling white heat and shows signs of melting. The point of the tool is then cooled either by plunging it in a bath of oil, such as linseed or cottonseed, or by placing the end of the tool in a blast of dry air. The exact treatment of high speed steel varies for the different kinds of steel, and it is advisable to follow closely the directions given by the steel makers. The container for the oil quenching bath is shown in the engraving, Fig. 2.

Heavy high speed tools having well supported cutting edges, such as planer or turning tools, are commonly used after hardening without tempering. If the construction of the tool is such that the cutting edges are comparatively weak they are often toughened by tempering or what is sometimes called "letting down" the hardness. A method recommended by several steel makers is to cover the steel with clean, dry sand and heat it to the required temperature, which should be shown preferably by a pyrometer. Milling cutters are heated to 400 deg., drills and reamers to 440 deg., for the largest sizes, and 460 deg. for the smaller sizes.

In annealing high speed steel the steel should be packed in an iron box or pipe of sufficient size to allow at least 1/2 in. of packing between the sides of the steel to be annealed and the sides of the box. It is not necessary that each piece of steel be kept separate from every other piece but it should be kept from touching the sides of the annealing box. It can be packed in powdered charcoal, fine dry lime or mica. The annealing box should be made air-tight and the whole thing heated slowly to a full red heat, about 1,475 deg. to 1,500 deg., and held at this heat from two to eight hours, depending upon the size of the pieces to be annealed. It should then be cooled slowly and not exposed to the air until cold.

E. A. Greame, D. L. & W.: The United States Bureau of Standards states that skilled observers vary as much as 100 deg. in the estimation of relatively low temperatures of steel by the color method and beyond 2,200 deg. it is practically impossible to make estimations with any degree of certainty. This would clearly indicate that the color method is not an accurate means to use for the determining of temperatures of steel. Steel can more properly be heat-treated and better results obtained when pyrometers are used. The importance of having proper equipment for the heat treating of steel cannot be overestimated. It is the cheapest equipment in the long run. Most failures in the treating of tool steel have been attributed to the steel but there can be hardly any question that 90 per cent of the failures result from the lack of knowledge of the proper method of treatment.

A tool to give the proper degree of efficiency should be tempered to give the proper hardness and still have sufficient toughness for the work in which it is to be used. At the

Scranton shops of the Delaware, Lackawanna & Western the scleroscope is used to determine the relative hardness of the steel. As a comparative measure of materials it is very accurate, rapid, simple and definite. It consists of a glass graduated tube with a small cylinder of steel which has a diamond point. This cylinder slides in a vertical direction in the tube and is allowed to fall upon a previously polished surface of the material to be tested. The height of the rebound of the cylinder is taken as the measure of the relative hardness. A pyrometer should be used to determine the proper heat treatment given for the steel. This instrument should be frequently tested to insure its accuracy. This can be done by testing with a standard pyrometer, or if low temperatures are used, by a standard mercury thermometer.

When rivet sets are to be hardened and a water hardening steel is used they should be dipped in the tank with shank down and running water directed into the cup of the tool. This treatment avoids the collection of hot water in the cup which would prevent the cup from properly hardening. We find that the vanadium alloy steel is most suitable for these tools.

In hardening shear blades, water hardening steel being used, the blade should be withdrawn from the bath at a temperature of about 225 deg. or just before the water ceases to boil on the surface. It should then be plunged into an oil bath. This treatment rapidly cools off the outer surface of the blade, making a very hard coating and by withdrawing it from the water before the water ceases to boil the interior of the blade will not have had time to become chilled. By placing it in the oil bath and quenching it further the interior of the blade cools slowly, leaving it very tough. The tool is then tempered in the oil bath in the usual manner.

To avoid cracking large spring dies when they are being hardened they are quenched in a tank of water and oil, the water being sufficiently deep to cover the threaded portions of the dies and the oil on top of the water covering the rest of the dies. By this treatment the threaded portion of

the die is hardened while the body of the die is only toughened. The die can then be drawn by the usual method. Care should be taken, however, to give the die a constant circular movement.

All reamers and long slender tools should be heated in lead pots and quenched in the usual manner. This will tend to eliminate the scale on the surface and the warping of the tool. A mixture of two-thirds salt and one-third cyanide of potassium, heated to a red heat for one hour and allowed to cool and harden and then mixed in the lead bath, is a good method to prevent the lead from sticking to the threads and small projections of the tool. The top of the lead pot should be covered with bone black.

The following method is used for hardening high speed steel threading dies, taps and other delicate high speed steel tools: The tools are first packed in a cast iron box or pipe with charcoal, care being taken that none of the articles touch the side of the box. The box is then covered and heated to from 1,950 to 2,050 deg. for from two-and-a-half to three hours, according to the size of the box. The box is then allowed to remain in the furnace. On opening the box the dies are removed individually and quenched in oil. All high



J. J. Sheehan, President,  
Tool Foremen's Association

speed steel tools not hardened by the pack method should first be preheated to about 1,500 deg. and then placed in a furnace of higher temperature and brought up to the desired heat. The benefit derived from this treatment is that a more lasting cutting edge is obtained due to the fact that the surface of the tool has not been exposed to a high heat for any material length of time. We have found that vanadium steels are best suited for concussion tools. In carbon and vanadium steels a higher temperature than is used for hardening should be used for annealing.

In most high speed steels 1,500 deg. F. is about the proper heat for annealing. On bringing the tools up to this temperature the furnace should be sealed, the heat turned off and the furnace allowed to cool gradually, and the contents should not be withdrawn until they are cold.

Owen D. Kinsey, formerly of the Illinois Central: To obtain maximum efficiency of tool steels the treatment of them must be scientifically handled.

The skill of the most experienced operator is inadequate to obtain correct hardening and drawing temperature by observation. The material and labor entering into the manufacture of tools presents an enormous annual expense to every railway system. The high priced steels improperly heat treated increase the cost of manufacture, to say nothing of the delays in production in the shops on account of not properly serving their purpose. Without the use of a pyrometer in the heat treatment of high speed steel there is considerable danger in burning away the cutting edges or warping the tool out of shape.

More than likely the tool will not be brought up to the proper temperature for fear of overheating it, which will cause the workman considerable trouble when it gets to the shop. Then, again, the tool may break on account of the temper not being drawn sufficiently to relieve the strain. This is a matter that should be carefully studied as a tool properly drawn will reduce tool breakage and the chipping away of the cutting edge. A drawing temperature of 450 deg. has been found to give the best results for high speed steel reamers, taps and milling cutters, and a much higher temperature is now being recommended by several of the large steel producers for large tools such as for planers and other machines. [Mr. Kinsey also described briefly the electric furnace equipment of the Illinois Central, which is being used at their Burnside shops for treating the tools. This installation was illus-

trated and described in the *Railway Mechanical Engineer* for August, 1916, page 423.]

DISCUSSION

It was generally agreed that the directions supplied by the manufacturers with their different steels should be closely followed in heat treating steel. Where steels of different grades are used in a shop they should be carefully marked as they are made into tools in order that they may be given the proper heat treatment. The advantage of the lead bath over the charcoal fire was explained as being due to the uniform heating of the tool by the lead bath. In a charcoal fire drafts of air will cause the tool to warp and the oxidation will cause soft spots on the tool. Mr. Bevelle explained the method of treating rivet snaps on the El Paso & Southwestern. Steel of .75 per cent carbon is used, which is hardened at 1,475 deg. and quenched in oil. The temper is not drawn.

There was considerable discussion concerning the advisability of the railroads making their own staybolt taps. Some roads find that they do not get as good results from the home-made tap as they do from those which are purchased, while others claim that much better results can be obtained. Mr. Nelson of the Soo Line stated that that road was obtaining very good results by making its own 24 in. taps from Firth-Sterling steel, .038 in. per ft. being allowed for shrinkage. The cost of the 13/16 in. and 12 thread staybolt taps is \$2, allowing 25 per cent for overhead charges. About one in fifty is lost by breakage. It was stated that 800 holes per tap should be obtained. One of the members who makes staybolt taps reported that 2,500 holes had been obtained from these taps. The Santa Fe does not permit an error of more than 1/48 of a thread in 6 in. Also the tool must be between .002 in. and .003 in. over size.



C. A. Shaffer, 1st Vice-Pres., Tool Foremen's Association



J. C. Bevelle, 2nd Vice-Pres., Tool Foremen's Association



Owen D. Kinsey, Sec.-Treas., Tool Foremen's Association

SPECIAL TOOLS FOR STEEL CAR REPAIRS

W. M. Robertson (Ill. Cent.): When steel freight cars were first introduced car department officers felt considerable anxiety relative to the facilities for maintaining them. It was soon found, however, that the problem was not nearly so troublesome as it at first appeared to be. It is the tendency on most roads for the car foreman to rely upon his own resources in the provision of special tools, as he has met with but little consideration from the general tool room and the locomotive department. It seems to be the opinion of the locomotive department that on account of the rough nature of car repair work the requirements in this respect are small, but the contrary is true; on account of the amount of this work handled it should be given very close consideration. Metal workers in the car department are not using jigs and the tools that were common in the locomotive department ten years ago because of the lack of co-operation among the foremen and in the tool department. It seems to me that the tool foreman is the man who can best improve these conditions. [Mr. Robertson then described a number of special tools for use in steel car repairs which have been adopted at the Harahan, La., shops of the Illinois Central,

among which were several that were described in A. H. Hatfield's article on "Riveting in Steel Car Construction," appearing in the *Railway Age Gazette, Mechanical Edition*

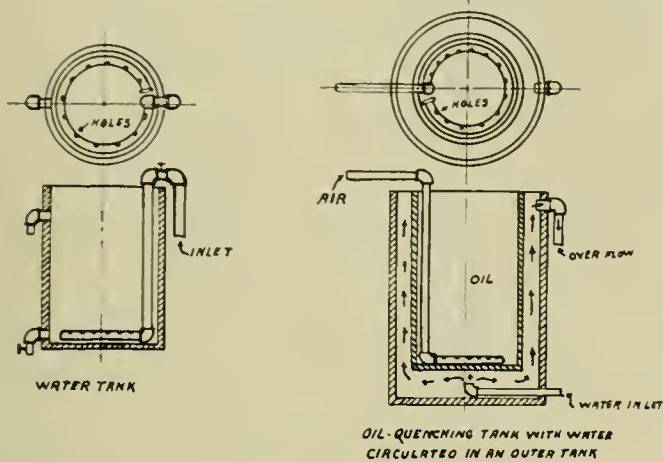

Fig. 1—Water and Oil Quenching Tanks for Heat Treating Steel

in January and February, 1915, pages 33 and 87, respectively.]

The following devices were also described: A simple device for holding journal box bolts while tightening the nut

Fig. 4 shows a "figure four" for use in straightening steel car sills. This is a convenient arrangement for jacking against and it will save considerable time, as it may readily be clamped to the rail.

J. W. Pike, Rock Island Lines, referred to a holder-on for use on the Boyer long stroke hammer. This device, as may be seen from the illustration, Fig. 5, consists of a special head which replaces the usual type of handle on the end of the hammer barrel. In place of the handle the end of the head is fitted with a cylinder of 2½-in. Shelby steel tubing, in which works the mild steel holder-on piston. The length of the piston is increased as desired by a piece of 1¼-in. pipe. The head is fitted with two ¾-in. air pipe connections, one for the holder-on cylinder and the other for the hammer proper.

E. J. McKernan presented a drawing of the jig for drilling brake staffs, shown in Fig. 6, which is used on the Santa Fe. This consists of a block of soft steel through which are holes for the brake staff; at right angles to these are holes bushed with tool steel for guiding the drills. This jig takes care of all the drilling operations which are required on the brake staff.

Drawings of the jacking stall for straightening steel under-frame cars, which has been provided at the Topeka shops, were also shown. A description of these facilities will be given in detail in an early issue of the *Railway Mechanical Engineer*.

J. E. Axley, C. & E. I.: The tool shown in Fig. 7 is used for boring steel and cast iron car wheels. The tools

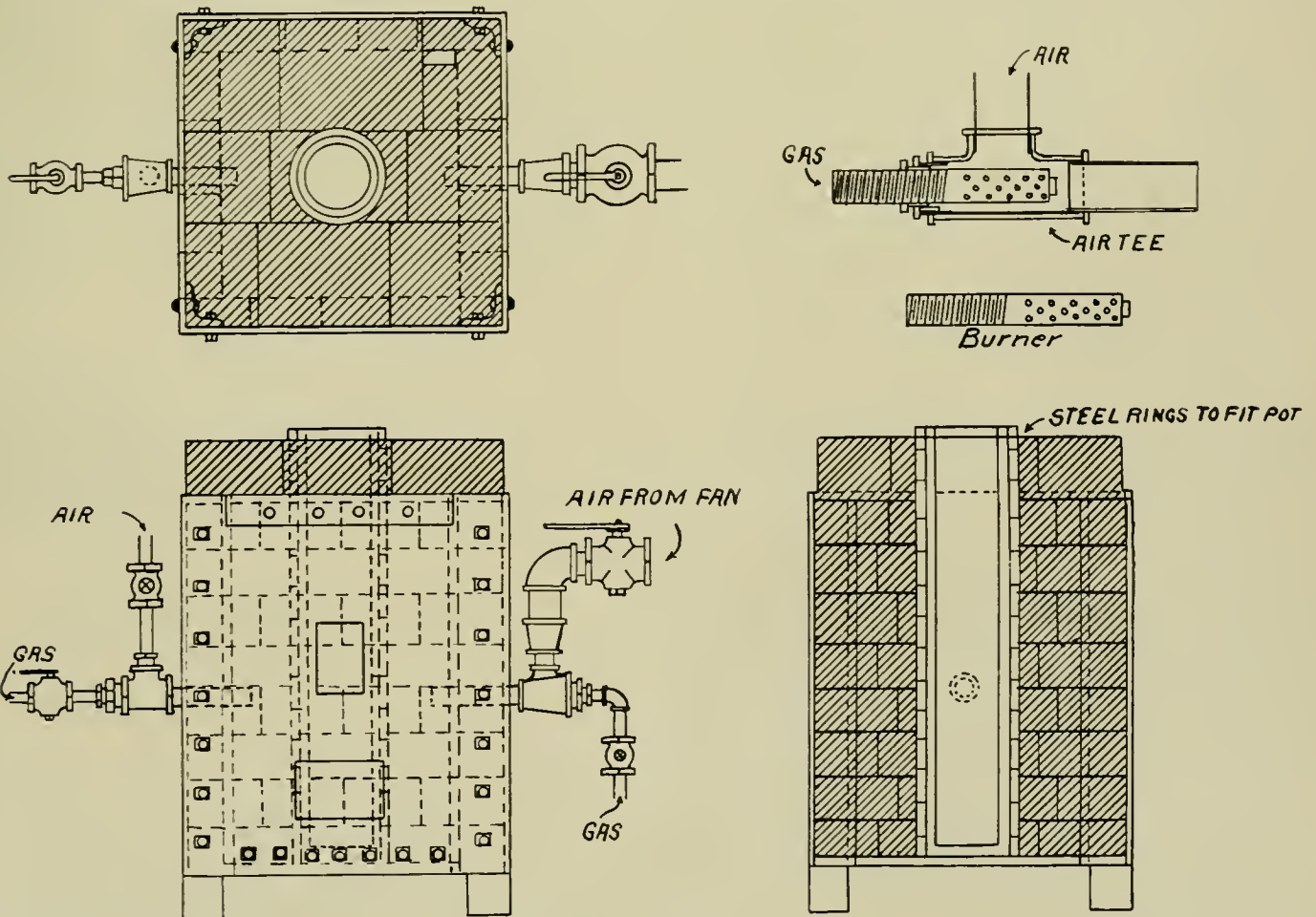

Fig. 2—Lead Pot Furnace

is shown in Fig. 3. This is lighter than an "S" wrench of the size required to hold the head of a journal box bolt and one man is all that is needed to use it.

are made from high speed steel and are used in the Davis expansion boring tool holder. They have a ten degree under cut which gives them a good cutting edge. The jig for

holding the cutter for cutting the under cut is shown in Fig. 8.

RECLAIMING MATERIAL

E. J. McKernan, A., T. & S. F.: All tool steel on the Santa Fe system is reclaimed. The steel is first returned to our Topeka shop for a general inspection, after which such material as is considered serviceable is held in reserve to be made up into small tools as we deem necessary. The short pieces of high speed steel are made into tips for lathe and planer tools, the tips being gas welded to shanks of tire steel. The short ends of old lathe and planer tools are drawn out and made up into square tools for use in Armstrong holders. Only the small chips that are removed in dressing the tools at the blacksmith's anvil reach the scrap, and at this time there is a good market for this class of scrap steel.

All broken high speed twist drills and reamers are reclaimed whenever the pieces are large enough to make this possible; otherwise they are placed in the scrap. A special effort has been made to reclaim all of this steel, which has worked out very economically. Had such a system not been in effect at this time there would have been difficulty in operating all of our machines, due to the shortage of high speed steel. Large washout plug taps that have become slightly worn are returned to Topeka, where they are annealed and recut to the next smaller size. These taps are all kept to standard, the diameters varying in steps of  $\frac{1}{8}$  in.

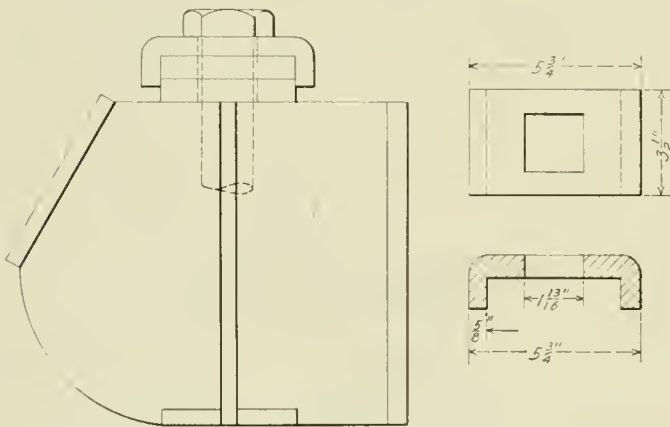

Fig. 3—Device for Holding Journal Box Bolts

All chisels, whether for use by hand or in air hammers, are made up into center punches when they become too short, the minimum safe length for regular service being four inches. Worn reamers are remilled and made to the nearest smaller size.

W. M. Robertson (Ill. Cent.): An air operated vise has proved to be a very useful arrangement for bolt work at the reclaiming plant. The operating mechanism usually consists of two 10-in. air brake cylinders which may be attached to an 8-in. bench vise by removing the hand operating screw. The latter is replaced by a long rod, to the end of which the two operating pistons are attached by means of an equalizer. It is not advisable to use a vise smaller than the 8-in. size because of the hard usage to which it is subjected. In connection with this we use a special air motor-operated arrangement for removing nuts from the old bolts. The motor is suspended over the vise with the spindle attached to an old flexible shaft used for driving tube cutters in the locomotive front end. When not in use the shaft may be swung out of the way to a bracket conveniently placed on the vise.

The pneumatic hammer shown in Fig. 9 will be found to be very useful on the reclaimation platform for straightening bolts and also may be used in the blacksmith shop, where better equipment is not available.

DISCUSSION

The discussion on this subject was largely devoted to the reclaimation of tool steel, the present condition of the market making the conservation of this material a matter of great importance. The principal use which has been made of small pieces of tool steel has been for tips welded onto the end of soft steel shanks, tire steel usually being used for the shanks. Several methods of uniting the tip and the

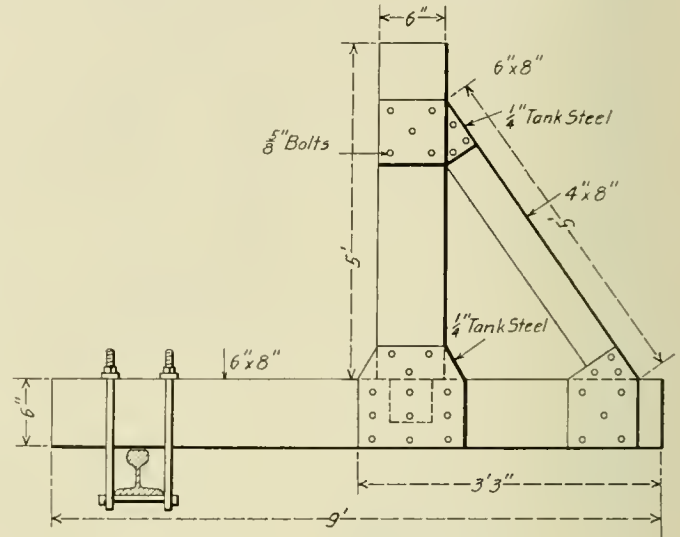

Fig. 4—Jack Support for Straightening Steel Car Sills

shank have been used, including welding in the blacksmith shop, electric welding, gas welding and brazing. All these methods have been used with more or less success, no difficulty usually being experienced except in the case of the larger size tools used on wheel lathes and planers. The oxy-acetylene process has been most generally used, the welds being made successfully in a variety of ways. On the Santa Fe this is no longer considered a reclaimation process, as the supply of scrap high speed steel has all been used. The tips are now made from bar stock and are charged at the price of the new material. A tool  $\frac{1}{2}$  in. by 1 in. by 8 in.

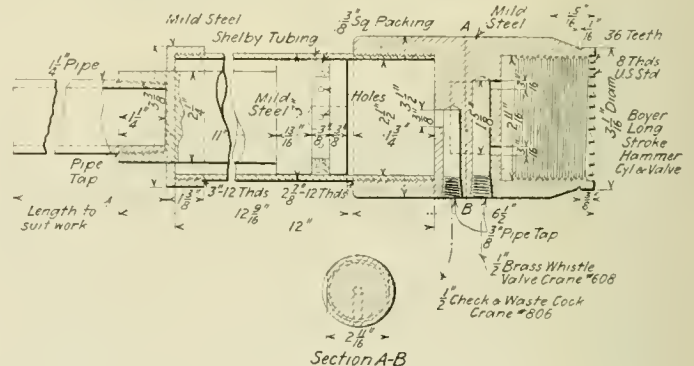

Fig. 5—Holder-On for Pneumatic Tools

can be made complete in this manner at a price of 43 cents as compared with a price of 74 cents for a similar tool of solid high speed steel. A tool  $1\frac{1}{4}$  in. by 2 in. by 14 in. which would cost \$9.53 if a solid bar of high speed steel were used, can be made for \$3.27 by using a high speed tip on a shank of tire steel. On the other hand it must be considered that the tipped tool has only about one-seventh the life of the solid high speed steel tool, it becoming necessary to reforge the shank and weld on a new tip when the tool has been ground back to within  $\frac{1}{2}$  in. of the end of the tip. Mr. McKernan pointed out that on this basis it would not

be considered economical to use the welded tools if it were possible to secure the high speed steel on the basis of the market existing before the war. The following statement shows the various items entering into the cost of a lot of 432 tools, ranging in size from 1/2 in. by 1 in. by 8 in. to 1 1/4 in.

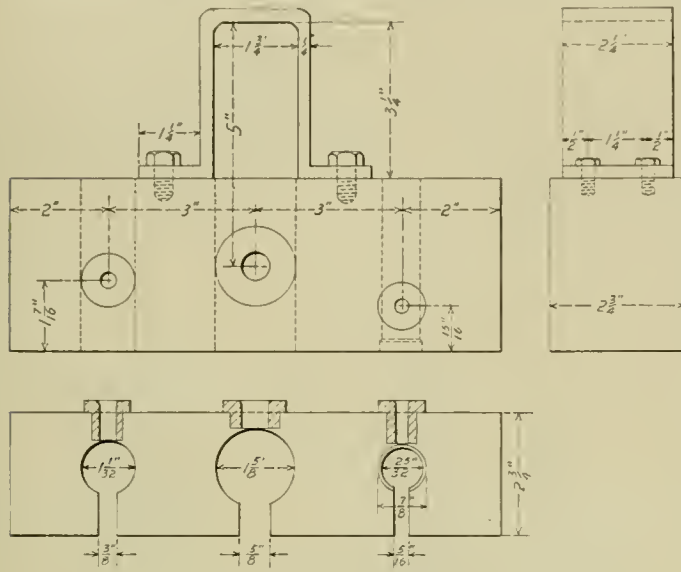

Fig. 6—Drill Jig for Brake Staffs

by 2 in. by 14 in., which were made at the Topeka shops of the Santa Fe:

1,497 lb. tire steel.....	\$15.91
279 lb. high speed steel.....	164.03
105 lb. No. 2 welding rods.....	15.75
35 lb. Norway iron for facing the tips.....	4.55
<b>Total material.....</b>	<b>\$221.24</b>
<b>Total cost, including labor and overhead.....</b>	<b>\$672.14</b>

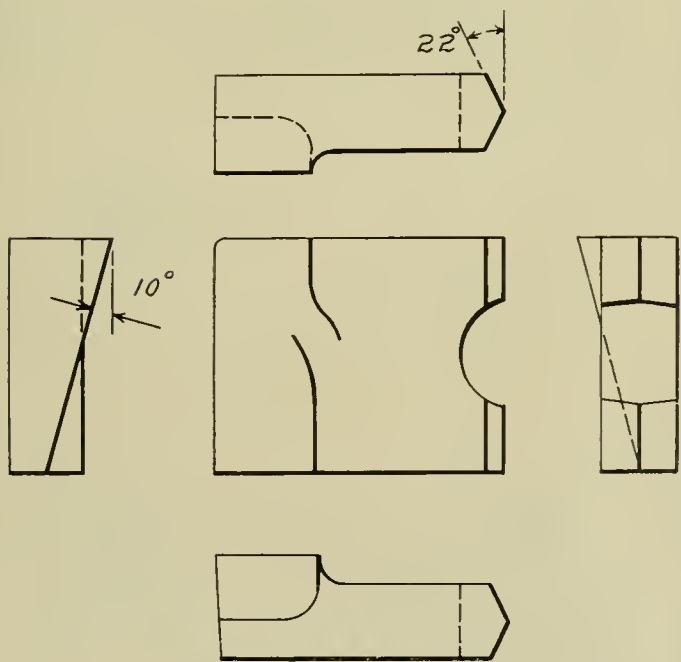

Fig. 7—Tool for Boring Car Wheels

Better results have been obtained in the heat treatment of the tipped tools, owing to the smaller size of the piece of high speed steel to be hardened. On the Santa Fe both the oxy-acetylene and the electric welding process have been tested and it has been found that the results of the former are more satisfactory. The quality of the high speed steel seems to be affected less by the former process.

On the Norfolk & Western the electric spot welding process is being used for this work. The adjoining surfaces of the tip and shank are corrugated and are cleaned before welding. The corrugations facilitate the quick heating of the surfaces by reducing the area of contact through which the current must pass at the beginning of the process. When the surfaces have fused, the tip and the shank are squeezed together and the weld made. The labor cost of this process is very small, as the tools can be welded about as fast as the material can be brought to the operator. The ends of inserted saw teeth which have become too short are used as tips for Davis boring bars, the tip of high speed steel merely being placed on top of the bar and welded by the above process.

Several members have experienced some difficulty in the use of the oxy-acetylene process from the cracking of the high speed steel at a point just above the weld. It was brought out in the discussion that this was probably due to the use of too high a temperature in preheating the tip. Considerable difference of opinion was expressed as to the best methods of doing the welding. In some cases both the shank and tip are ground to provide clean surfaces before

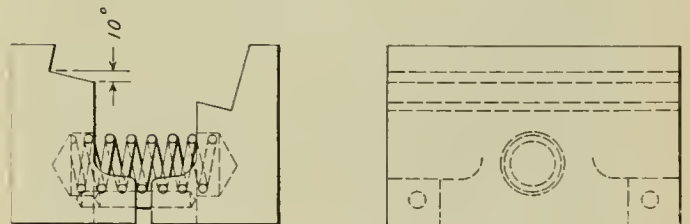
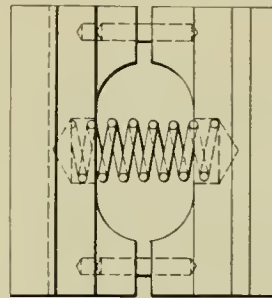

Fig. 8—Jig for Forming Wheel Boring Tools

welding and the tip is faced with soft iron. Others weld directly to the unprepared surfaces, using a welding compound. In several shops it is the practice to fuse and puddle the metal on both surfaces, thus carrying the scale out of the weld and requiring no preparation of the surfaces. After the tips are welded on in this manner the tools may be drawn down to any shape and size required.

The electric welding process is being used on the Southern Railway for this work. The tips are made in dies and are welded to the shank without preheating, the electrode process being used. The tools thus made are used on all the heavy machines. The reclamation of high speed steel has developed so far on this road that the chips which are too small for further use are melted up and worked over into tips.

The brazing process, where used, has been confined to tools of small and medium size.

**SPECIAL TOOLS FOR THE FORGE SHOP**

George W. Smith, C. & O.: Hundreds of hand hammers have been made in dies under the steam hammer with very good results. A model is made out of open hearth steel on a lathe, and two dies are formed under the hammer. The blocks of the dies are provided with long handles which are connected at the end. The dies are brought up to the proper

heat and the former made on the lathe is placed in the center of the dies under a steam hammer. The impressions in the dies are made in this manner, the former being revolved between the strokes of the hammer. The hammers are made in the dies from open hearth steel rods, a large number being turned out in a short space of time. The hammers having thus been formed are reheated and placed in a forging machine and the eye is punched and the sides flattened in one operation. The fins are ground off on an emery wheel. The hammer is then tempered. These are used for general rough work and are produced at a cost of from six to seven cents each, exclusive of the handles.

Scrapped tires are used for making shear blades, large punches, and dies, the steel being cut to proper length by means of the oxy-acetylene cutting process. The steel possesses enough carbon to take a sufficient temper to do the work and in a majority of cases will stand the wear better than ordinary cast steel. Back-out punches for steel car work are also made from this grade of steel and give very good results.

Vibrating cups for Mallet type locomotives are made out of scrap ends of superheater tubes, the ends being cut to

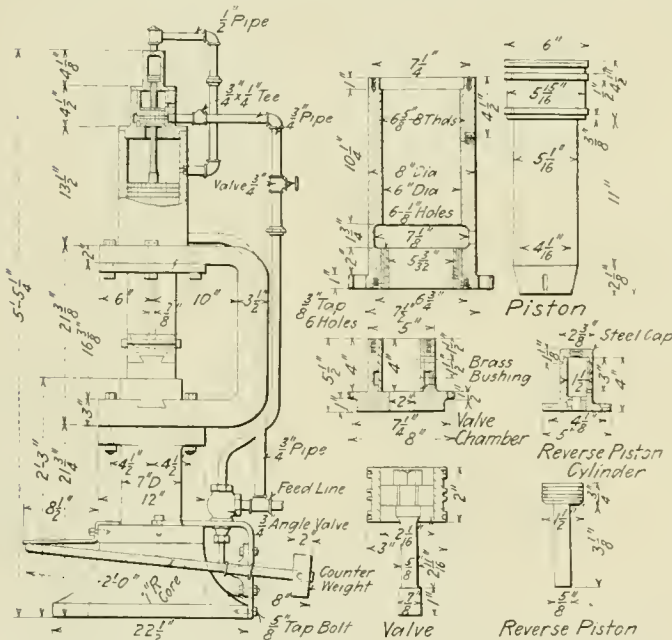

Fig. 9—Pneumatic Hammer for Reclaiming Scrap

the proper length and shaped in a die of the proper shape. They do not require any machining other than trimming up the edges. Hexagonal nuts for crossheads of Mallet locomotives are made out of steel car scrap. The punch and die for making these nuts are made of tire steel. A smooth forging is produced with one blow of the steam hammer. The nuts are reamed and tapped on a turret lathe and no further finishing is necessary.

Spring steel is used for making S-wrenches. A suitable die and punch are made to form the ends and enough stock is left in the center of the wrench to draw it out under the steam hammer to the required length. The ends are punched to the proper size for the nut, and the wrench is bent in a former. These wrenches are strong and light and give very good service, being distributed over the entire system for all classes of work.

DISCUSSION

The use of tire steel as a substitute for carbon tool steel is considered satisfactory in many cases, but opinions vary as to the extent to which the substitution can successfully be made. It has been used successfully for shear blades,

the material receiving the same heat treatment that would be accorded to carbon tool steel, viz., a quenching temperature of about 1,450 deg. F., the blade being quenched for a distance of about two inches back from the cutting edge.

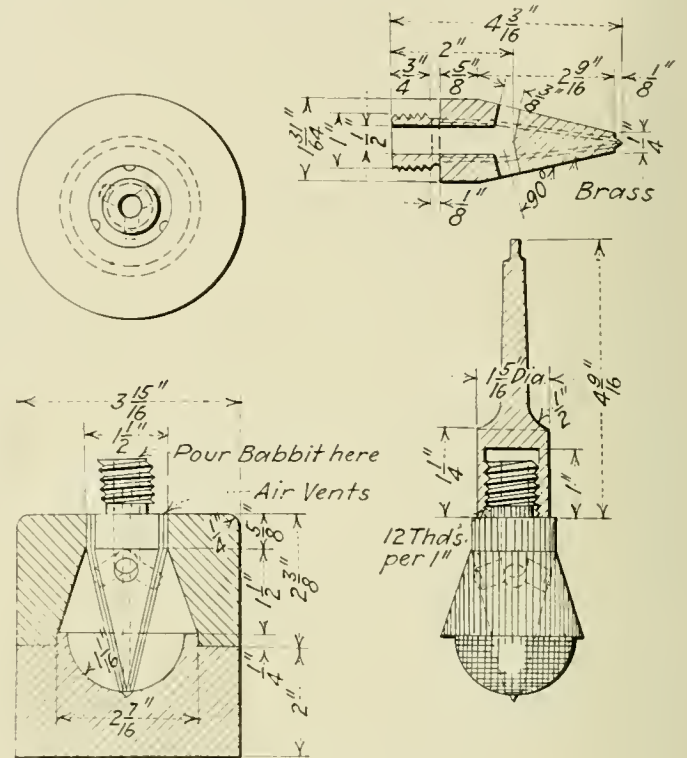

Fig. 10—Grinder for Superheater Header

Several roads use tire steel for forging die inserts and punches, the material being hardened and drawn back to a light straw color. For hot work it is considered superior

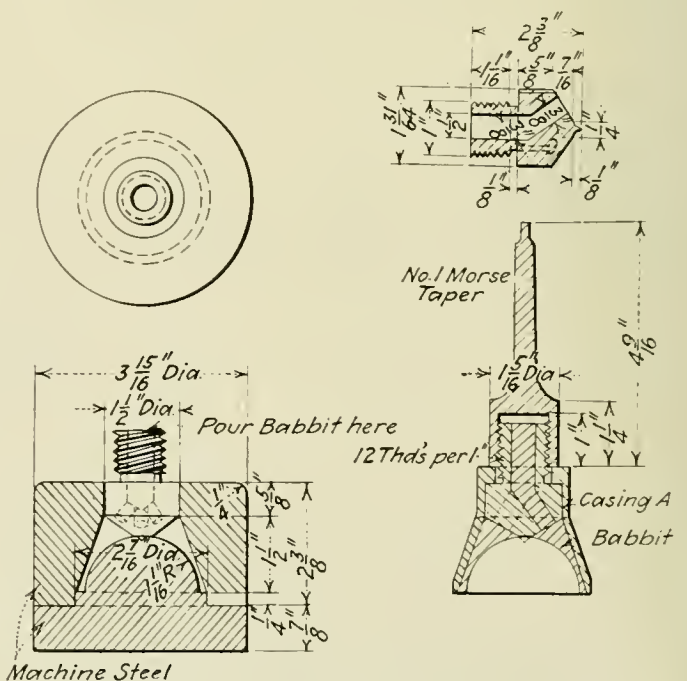

Fig. 11—Grinder for Superheater Units

to carbon tool steel because of its greater toughness and durability under shock. It was not considered generally successful, however, for shear blades subject to use on all kinds of material, owing to the fact that it will not take a

sufficiently high temper to stand up under the harder grades of steel. It is used to a large extent for blacksmiths' swedges and chisels, but in some cases, owing to the tendency of these tools to split as well as burr when made of this material, its use has been discontinued.

**GRINDING WHEELS AS APPLIED TO LOCOMOTIVE REPAIRS**

H. B. Miller, Big Four: This subject includes the grinding of all tools or machines which are used in the repairing of locomotives. Successful grinding must start with the

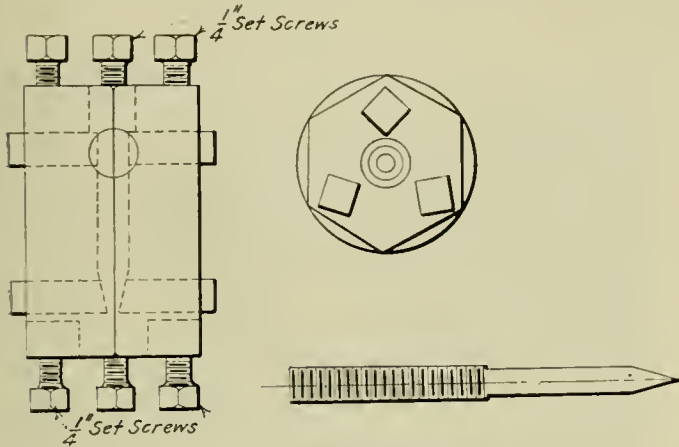

Fig. 12—Box Tool for Refinishing Ends of Gage Cock Stems

condition of the grinding machine, which must have properly fitted bearings and a proper range of speeds and feeds, and must be properly lubricated. The next consideration is the material which we are to grind. The character of this must be known in order that we may select a wheel of the proper grain, size and shape. Much time is saved in grinding by having the proper fixtures with which to do the work. In grinding ball reamers a device that can be moved from the center each way to take care of the radius, the movement being effected by means of a lever, has made it possible to use a ball joint where an angle was formerly used.

In different repair shops the system of handling tools

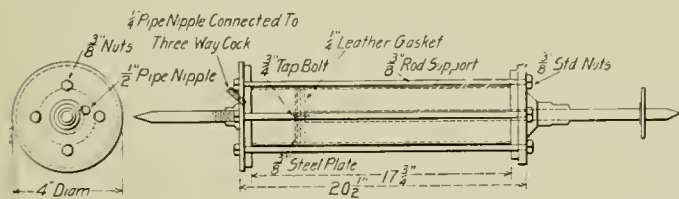

Fig. 13—Jack for Removing Expanded Tires in the Roundhouse

must necessarily be adapted to the working conditions of the shop, but the grinding should be done in the tool room, the tools being placed in the checking room for distribution. As the tools are used and returned they should be checked over, re-ground and re-marked if necessary, after which they should be placed in the checking racks. An essential point in grinding tools is the provision of the proper degree of clearance for the work to be done by the tool. We find a difference in the cutting qualities of straight and spiral reamers with the same degree of clearance. In this case we are using a standard degree of clearance on each tool according to the work for which it is intended, as we have found that too much clearance and no clearance are equally worthless.

A. Sterner (C., R. I. & P.): Although the application of grinding to the finishing of piston rods and crank pins

appears to be unlimited, experience seems to indicate that the old practice of turning and rolling is better. This is due to the fact that the tough material of these parts retains particles of the abrasive, the bad effects of which are very well known. Parts which do not have any severe work to do, and which are required to have a finished or semi-finished surface, should always be made with as little stock as possible and may be finished by grinding. Working surfaces should not be ground unless they are carbonized, chilled or tempered.

The efficiency of all grinding wheels depends upon their speed and the ability to make every grain on the surface work. The speed must not be too fast, however, as this causes the binding material to melt and the surface of the wheel becomes glazed.

Do not use a grinding wheel with a spindle worn loose. With four or five double thicknesses of lacing on the belt it is not difficult to figure out the result. Do not mount it on a stand which is not securely held down. Never allow water to leak on a common emery wheel or keep it in a hot

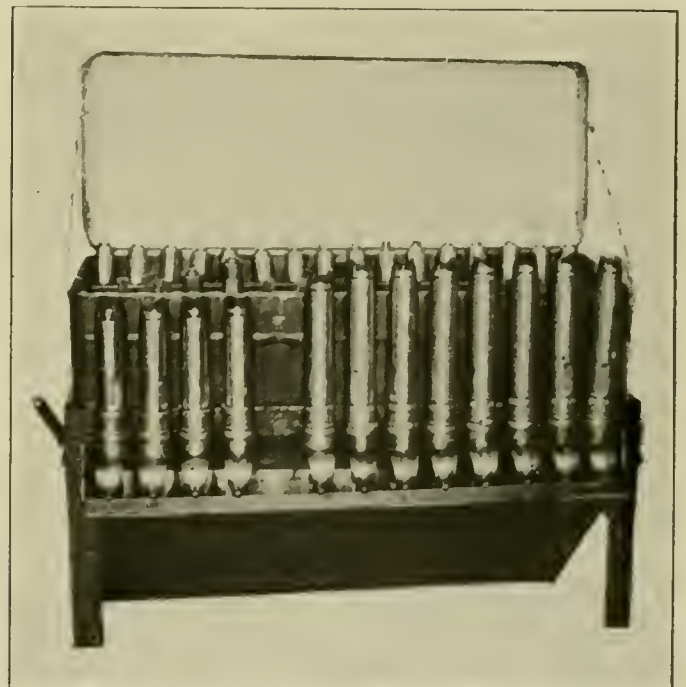

Fig. 14—Lubricating Tank for Pneumatic Hammers

place, as it contains glue. Do not run it at speeds other than those recommended by the manufacturer, and always follow his recommendations as to the type of wheel to be used for various classes of work.

When a grinder is used under other conditions than these it is being abused and is a constant source of trouble. On the other hand, if these simple facts are kept in mind emery wheels are the most useful tools to be had.

**DISCUSSION**

The question arose as to whether or not the grinding of piston rods and air compressor rods affected the life of the packing, especially where metallic packing was used, it being claimed that the grains from the grinding wheel would penetrate the pores of the steel rod and thus score the packing. It was claimed by the representatives of grinding wheel manufacturers who were present during this discussion that this was not true as has been repeatedly proved by tests. Where grinding wheels are used for this purpose, however, care must be taken to have them true to diameter with no high spots and they must be run at the proper speed. Some roads prefer rolling the rods to grinding them

claiming that a smoother surface can thus be obtained.

The question of the maintenance of the grinding wheels also received considerable discussion. Several roads detail a man, such as the belt foreman, to make daily inspections of the grinding wheels throughout the shop. It is his duty to keep them properly dressed and well lubricated. It is also necessary to keep the peripheral speed as nearly constant as possible. This is done by removing badly worn wheels and applying them to machines of higher speed. For instance, the practice on the Santa Fe is to remove a 24-in. wheel when it has worn down to 16 in. and apply it to a machine having a greater speed. Every step possible should be taken to prevent the workmen from abusing the grinding wheels. Wheels should be provided for both rough and fine work, so that the good wheels will not be ruined for the fine grinding.

JIGS AND DEVICES FOR THE ENGINEHOUSE

A. Connell, Kansas City Southern: Until recently the use of special tools and jigs for doing the various kinds of work in the roundhouse was unknown, with the exception of an occasional tool made by individual workmen. The back shop received all the attention, the workmen there having many useful special tools. Because of this condition the term "roundhouse job" was commonly used to indicate work that was half done or done just well enough to last one trip of the engine, and it was customary for men in the roundhouse to spend several times as long in doing their work without special tools as would have been required with them. Considerable credit is due the Tool Foremen's Association for the development of tools and jigs for the roundhouse.

Figs. 10 and 11 show a very successful superheater unit grinder for roundhouse use. There are two grinders in the set; one for the ball on the end of the superheater unit and the other for the socket in the header. These are made up of steel centers on which are cast the babbit grinding surfaces in the special moulds, as shown. These are arranged to be threaded into the end of a No. 1 Morse taper shank and, like all babbit grinders, may be easily renewed.

F. D. West (C. G. W.) showed a number of special tools for the enginehouse. A box tool for refinishing the ends of leaky gage cock stems is shown in Fig. 12. This has two sets of cutters, the first set turning off the threads and the other tapering the end of the spindle. This has the advantage that it always maintains the proper relation

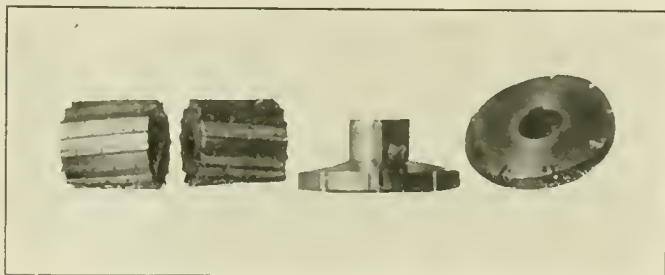

Fig. 15—Milling Cutters and Valve Chamber Boring Cutters

between the inner end of the threads and the seat. It may easily be used by hand and it can be used in making new stems. In the latter case a brass rod of the required size is threaded for its entire length and then cut up into suitable lengths. These are gripped in a drill press chuck and run down into the tool.

Fig. 13 shows a tire removing device which is in fact a special type of air jack. After the tire has been heated and expanded the end of the jack is placed against the inside face of the opposite tire. The plunger pushes the tire off and is prevented from traveling out too far by a 3-in. collar which strikes the wheel center.

DISCUSSION

Several of the members spoke strongly in favor of the tool foremen giving their best thought to devising special jigs and tools for use in the enginehouse, for the need of such things in the enginehouse is very great. Every means should be given the enginehouse force to make quick and thorough repairs, for then the power would be kept in service longer and would be able to make a greater mileage between shoppings, all of which means a more efficient mechanical department. It was designated as the "emergency hospital," for the locomotive and the "doctors" therein should be provided with satisfactory tools. The outlying enginehouses should be given even more assistance than

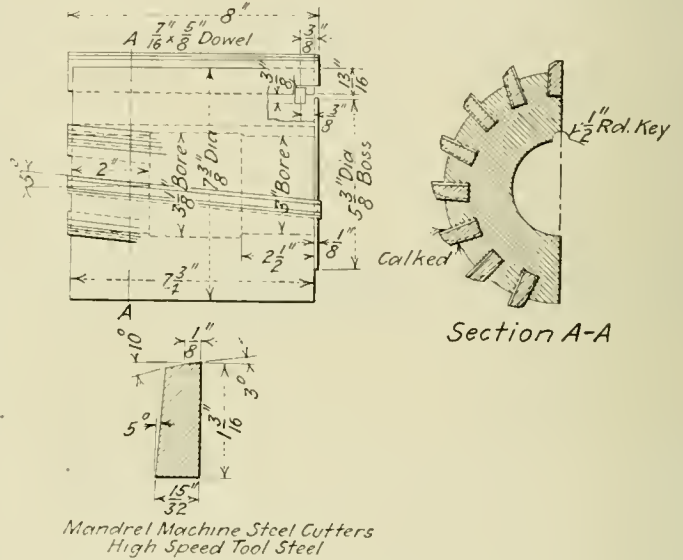

Fig. 16.—Details of the Milling Cutters Shown in Fig. 15

those at or near the back shops, for at these points in case of emergency the proper equipment can be borrowed while the outlying enginehouse would have to either hold the engine for a much longer time or send it to the main shop.

Several special tools used at some enginehouses were mentioned, among them being a tool for grinding superheater unit joints. It consists of a fluted ball of proper contour provided with a square pilot projection. A piece of emery cloth is placed over this ball, the square pilot keeping it from rotating, and the joint ground. The tool will never wear out, the wear coming wholly on the emery cloth, which is replaced after having served its purpose. J. C. Bevelle told of using a floating liner in the back end main rod brass which on some engines eliminated the necessity of renewing the brasses at the end of every trip.

TOOL ROOM EQUIPMENT AND TOOLS

J. C. Bevelle, El Paso & Southwestern, El Paso, Texas.—Fig. 14 illustrates a very convenient method of handling pneumatic riveting and chipping hammers. This is an oil tank with two compartments, one for the chipping hammers and the one below for the riveting hammers. The hammers are returned to the tool room at the end of each working day and placed in this tank for the purpose of lubricating them. They are submerged in the oil and remain there until the following morning, when they are lifted out and allowed to drain. The top section has a 7/8 in. round rod in the center and at the top of the tank extending from one end to the other. On this the hammer rests and drains.

The lower section is made in a triangular shape, having an opening on the front of about 6 in. This is used for the riveting hammers. They are also drained by being stood up, as shown, and held in position by a spring clip. The



throttle lever rests against a 1 in. angle iron which supports the hammer and also holds the throttle valve open, allowing the oil to drain out of the hammer. Each hammer is numbered and has its place in the tank. Each time the hammers are returned to the tool room they are submerged in the oil. This keeps the tools properly lubricated and reduces the cost of repairs about 50 per cent. The tank is set on rollers so that it can be moved to the most convenient location. It has a galvanized iron top so that it can be closed and keep the oil from getting dirty. Also the oil is less apt to catch fire from any spark from an emery wheel, etc. The tank frame is made of  $\frac{3}{8}$  in. by 2



Fig. 17—Interior of Tempering Plant for a Small Shop

in. angle iron and the tanks are made of  $\frac{1}{8}$  in. tank steel. The oil used is a mixture of one-third kerosene and two-thirds lard oil.

Fig. 15 illustrates a pair of milling cutters on the left, and two valve chamber boring cutters on the right. Fig. 16 is a drawing of the milling cutters and is self-explanatory. The milling cutters are used for general slab milling and are very efficient and economical. They are made of high speed steel blades inserted in a soft steel body, and, when working, can be used singly or in pairs. When placed together on the arbor they measure 16 in. over all. This covers the average run of work. The blades are set in with a dovetail and on an angle of 5 deg. as shown in Fig. 16. The blades lap in the center so that they make a very smooth cut. They have taken the place of solid cutters and also peg milling cutters in this shop. They will produce a heavier chip and smoother surface than the peg cutters that we have used. They are easy to handle on the grinding machine, as they are not so long and heavy as the others and it is easy to replace the blades when they are worn out.

The two valve chamber boring cutters shown on the right in Fig. 15 are used on a regular portable boring bar and are used instead of the spider with boring tools. We have three for each size of valve chamber; for instance, a 12 in., 12  $\frac{1}{16}$  in. and 12  $\frac{1}{8}$  in. When the chamber is re-bushed we use for the first boring the 12 in. cutter, for the second boring the 12  $\frac{1}{16}$  in. cutter, and for the third boring the 12  $\frac{1}{8}$  in. cutter. Each boring is done with one cut and a heavy feed and a finish is produced in the chamber that cannot be done with the spider and boring tool. The accuracy of the tools is maintained in the tool room and when the chambers are bored they are exactly to size and do not have to be calipered or bothered with by the operator. This also standardizes the valve chambers, making them a given size, and when they are bored they are lettered clearly on the outside, *A*, *B*, or *C*. The letter *A* signifies that the bushing is of its original size, the letter *B* signifies that it has been re-bored once; the letter *C* signifies that it has

been re-bored the second time. With this standard it is only necessary to carry three sizes of packing rings, sizes *A*, *B*, and *C*. The rings are turned after being cut, so that they are perfectly round and fit the chamber. These cutters are made with high speed steel blades inserted in a cast iron body.

Figs. 17 and 18 show a very efficient tempering plant for a medium sized railroad shop. It consists of a furnace with three sections for hardening; a crucible section, an oven section and a forge section; a tempering oil bath furnace, quenching tanks and table for the tools. The hardening furnace is equipped with a high resistance pyrometer, with a thermo-couple leading to each section. The tempering bath is equipped with a thermometer, registering up to 650 deg. Each section of the hardening furnace has heavy linings so that it can be used for hardening high speed steel. The crucible section can be used for hardening with molten lead or borium chloride; also, small tempering can be done in this section. The oven section is used for hardening dies, milling cutters, large taps, etc., and the forge section is used for hardening machine tools, although its range of work is very wide.

The tempering bath shown at the right in Fig. 18 is one of the most valuable tools in a shop. A large quantity of tools can be placed in this bath and the temper drawn to an exact point. It is customary to harden all tools on hand to be hardened and draw them all by one heating of the tempering bath. Different tools require different drawing. This is done with small wire baskets so that the tools can be taken out as they reach the required temperature. In the left hand corner of Fig. 17 are the quenching tanks, one for clear water, one for salt water and one for oil. These are equipped with screen pans, so that the tools can be raised out of the liquid and allowed to drain. The oil tank is equipped with a coil of pipe in the bottom, connected with the blower line, which keeps the oil circulating, thus giving the tools a more uniform hardness. The tanks are made from old air drums taken from scrap. This plant is in the tool room and under the tool room foreman's charge. The hardening furnace is also used for pre-heating high

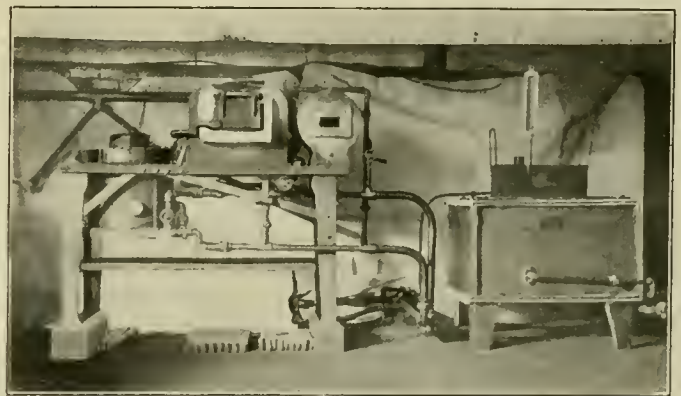

Fig. 18—Another View Showing the Heat Treating Equipment

speed steel tips and tool shanks, when they are to be made into machine tools, one section heating the shank to 1,450 deg., and the other section heating the tip to 1,850 deg. These furnaces are operated with manufactured gas.

ADDRESS BY MR. CARNEY

J. A. Carney, superintendent of shops, Chicago, Burlington & Quincy, addressed the convention in part as follows:

I do not want to take up your time in going into the details of how you should hold your file, the construction of tools and things of that sort that you all know more about than I do. What I want to touch on is not so much details as it is the matter of toolrooms in general. The function of a tool-

room is to look after the tools which are used by the productive workers in the shop, whether it be a machine shop, a locomotive erecting shop, or a car shop. I have in mind one toolroom which is in charge of one man. He occupies a room about 10 ft. square and his sole duty is to repair cutters for bolt trimming machinery. I have in mind another toolroom that has more machinery in it than we have in the Aurora shops of the Burlington. These are the two extreme limits.

The province of the toolroom is to make the tools that are needed, to maintain them in such a condition that when they are wanted they are ready to be given out, and to have them at hand so that there will be no delay to the men who call for them. I had an experience some years ago that illustrates this point. We had a hurry-up job, and it was not done on time; on investigating the matter the excuse was made that "we could not find our tools." I had occasion to look into this matter in detail and I found that the statement was true. It had been the practice for each man to get the tool that he wanted, to use it, and then throw it down on the floor. If someone else wanted this tool and remembered who had used it last he might be able to find it on the floor; if he did not find it there he kept on hunting until he did find it. The result was an enormous amount of time wasted in chasing up tools. There was no toolroom for this particular department and never had been. I asked the men whether they would use a toolroom if we would give them one, and they agreed to do so. So a toolroom was built. This was not a manufacturing department and there were no machine tools required; the toolroom was simply a place to keep the special articles that were needed at various times in the work of the department. When they took a tool out of the toolroom and used it, a majority of the men would put it back. A few, however, said they did not have time to do this. I told the majority of the men who are living up to the rules that I did not want to say anything to the others, but that every time they found a man dropping a jack, a special bar, or whatever it might be on the platform and going away and leaving it, I wanted them to get after him. They did this and the second day we had no more trouble of this kind.

The toolroom can be a great factor in the safety movement. As you know, the men who use hammers, chisels, etc., have their own kits. These tools become dull, the heads become burred and the tools are unsafe. I think everyone can recall someone who has had an eye injury or who has cut himself badly from the cracking off of the head of a cold chisel. If the toolroom will carry in stock a lot of cold chisels, sharpened and ready to be delivered, the men may be saved a lot of time. When a man turns in his defective chisels the ones which he receives are ready to go to work. He does not have to go to the grindstone or run over to the blacksmith shop and spend a lot of time getting them dressed. That is the thing I have in mind: the importance of the toolroom in having things ready and in good condition when wanted. The motto of the toolroom should be "a place for everything and everything in its place." That refers to everything from the commonest cold chisel up to the most complicated tools that can possibly be made.

**OTHER BUSINESS**

The following officers were elected to serve for the ensuing year: President, C. A. Shaffer, Illinois Central, Chicago; first vice-president, J. C. Bevelle, El Paso & Southwestern, El Paso, Tex.; second vice-president, W. M. Robertson, Illinois Central, New Orleans, La.; third vice-president, J. B. Hasty, Atchison, Topeka & Santa Fe, San Bernardino, Cal.; secretary-treasurer, R. D. Fletcher, Belt Ry. of Chicago, Chicago; chairman of the executive committee, B. Henrickson, Chicago & North Western, Chicago. The association voted to hold its next convention in Chicago.

**PORTABLE AIR HOIST**

BY E. A. MURRAY

Master Mechanic, Chesapeake Ohio, Clifton Forge, Va.

The accompanying engraving shows a form of portable air hoist suitable for roundhouse work in cases where the type of floor used permits of its use. This hoist was made in the shops at Clifton Forge and is used for lifting engine fronts, air pumps, smokestacks, etc. The construction is clearly shown in the illustration. The cable which is shown with a broken end is secured to the cleat on the vertical wooden post

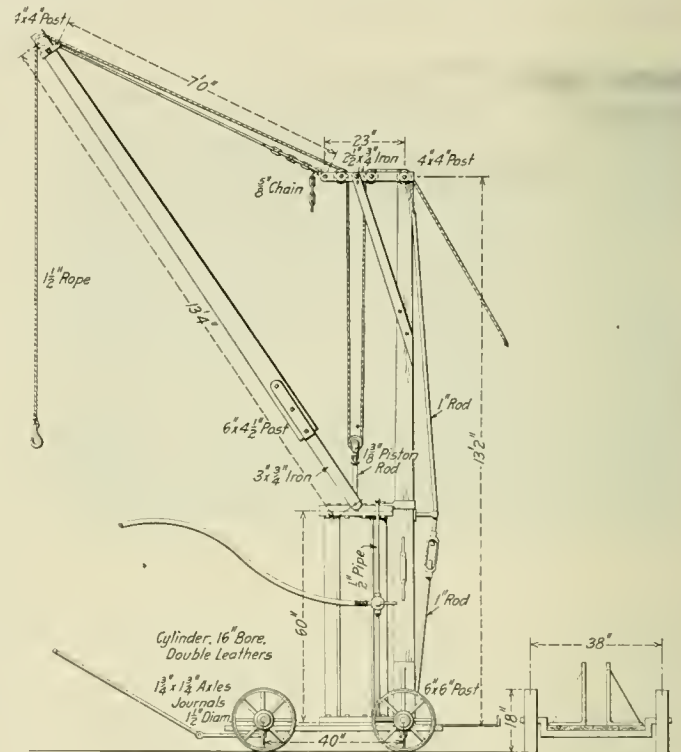

Portable Air Hoist for Roundhouses

in front of the air cylinder. When the hook on the end of the cable is made fast to the object to be lifted the piston in the cylinder is at the top of its stroke; when the slack is taken out of the cable it is fastened to the cleat.

**BRITTLINESS OF ANNEALED COPPER.**—This was the subject of a paper at the annual convention of the American Electro-chemical Society. The conclusion was drawn that brittleness of copper developed during heating in the process of manufacture and frequently ascribed to "burning" is in reality a deoxidation. With ordinary commercial copper, serious brittleness begins to appear at 400 degs. C. in dry hydrogen, at 600 degs. C. in wet hydrogen.—*American Machinist.*

**DETERMINING CYLINDER CLEARANCE TRAVEL.**—Clearance travel in a steam or ammonia cylinder may be determined by inserting a piece of lead or soft solder wire between the piston and the head so that it will be flattened between at the end of the stroke. The amount of clearance is then found by a micrometer. This thickness of the flattened wire expressed in fractions of an inch, divided by the stroke in inches, gives the percentage of clearance. If the volume of the clearance space is to be determined, the machine is turned over so that the piston stands at the end of the stroke, the exhaust valve is closed, and the space is filled with oil. This gives the volume or total clearance. As a check the oil should be measured both as it goes in and as it is drawn out of the cylinder.—*Power.*

# New Devices

## ADJUSTABLE DETHREADING ATTACHMENT FOR STAYBOLT MACHINES

The operation of the reducing or dethreading tools, by which the threads are turned off the body of the bolt in Lassiter staybolt machines, is automatic for each length of bolt but a separate set of profile strips is required for each length of bolt, these strips being removed and replaced whenever the bolt length is changed. This not only requires the maintenance of a large stock of profile strips but involves the loss of considerable time in changing and adjusting the strips. An attachment for this machine has been patented by S. L. Gary, 401 West 33rd St., South Richmond, Va., which is designed to overcome these difficulties. This attachment provides a single set of adjustable profile strips

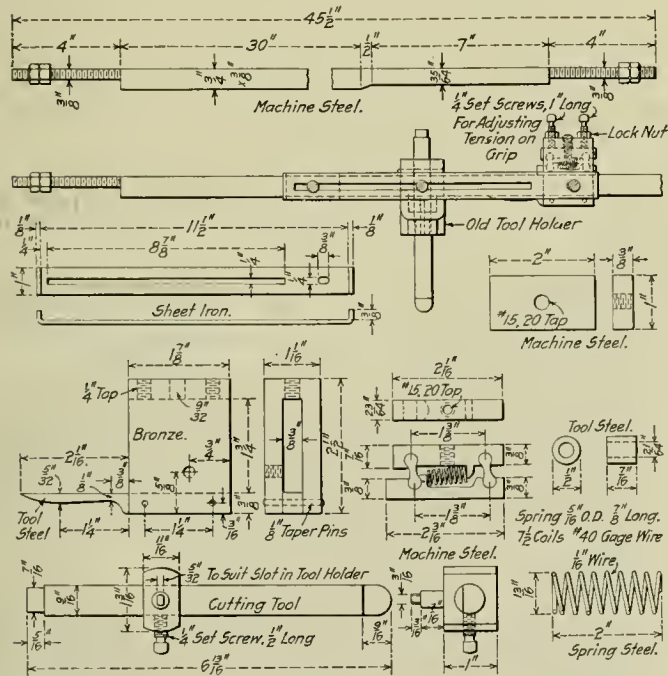

Dethreading Attachment for the Lassiter Staybolt Machine

which may quickly be set for any desired staybolt length, adjustment also being provided for variations in the length of thread at either end of the staybolt.

In the Lassiter machine the staybolt is held in a vertical position by a chuck at the lower end and revolved about its own axis. The threading dies are contained in a sliding head, guided by two vertical rods and fed by gravity. The dies are opened and closed automatically, closing in the upper position through the action of an adjustable lug secured to one of the vertical guides, and opening at the end of the cut in a similar manner. In addition to the dies the cutter head also contains two horizontal cutting tools placed opposite each other, the cutting ends of which are normally held away from the surface of the staybolt by means of springs in the head. A roller attached to the shank of each of these tools bears on the surface of a vertical control bar

one of which passes through each side of the head and is rigidly fixed at the top and bottom parallel to the guide rod. By means of profile strips, properly located on the edges of the control bars, the rollers are forced out from the bars and the cutters are fed into the staybolt at any desired distance below the upper end. As the dies feed downward the cutting tools continue to remove the threads from the body of the bolt until an offset near the lower end of each control bar is reached. These permit the springs in the head to draw the cutting tools back from the work, thus leaving the threads on the lower end of the bolt.

The drawing shows the details of the adjustable profile attachment. One of the cutting tools is shown but the details of the head are not included as the standard Lassiter head is used. At the top of the drawing is shown one of the control bars, which is made from machine steel and finished to a 3/4-in. to 3/8-in. section for the greater part of its length. For a short distance at the bottom the depth is decreased from 3/4 in. to 35/64 in. The profile strip is made from tool steel and bears against the edge of the control bar. It is held in place by a U-shaped bronze slide and a toggle clamping device which automatically grips the bar and normally prevents the profile strip from sliding downward.

By referring to the details of the clamping device it will be seen that it consists of two rectangular blocks separated by two small struts, recesses for the ends of which are provided in the adjoining faces of the blocks. When the wedge is in place in the slide the outer block is prevented from moving vertically with respect to the slide by means of a tap screw passing through the back of the slide. A coil spring, 2 in. long, is placed between the blocks, one end bearing against a shoulder on the inner block and the other against a shoulder on the outer block, the spring tending to move the inner block upward and thus bring the toggle action into play. The gripping power of the device may be adjusted by means of two set screws through the back of the slide, which bear against the outer block.

When assembled on the control bar a slotted plate is attached to the slide, a screw on the cutter head sliding freely in the slot. The length of the slot may be adjusted by means of a sliding block at the upper end, which may be clamped in any position desired. In operation, the screw on the cutter head will be at the top of the slot as the dies begin their downward feed on the body of the staybolt. As the head feeds down the rollers on the dethreading tools will strike the profile strips and be forced out from the control bars, thus causing the tools, which follow directly after the threading dies, to be fed into the staybolt. It will be noted that the inner block of each profile strip clamping device projects slightly above the top of the slide. As the head moves downward it strikes the ends of these blocks, thereby releasing the profile strips and permitting them to move down with the head. When the slides reach the offsets in the control bars the springs in the cutter head will force the profile strips into the offsets, which permit the ends of the tools to clear the staybolt for the remainder of its length.

When the bolt is finished the dies are opened automatically and the head is then moved up to permit the removal of the finished staybolt and the insertion of another. Until

the screws in the sides of the head reach the top of the slots the profile strips will remain at the bottom of the control bars; then they will be pulled up, the clamps being released automatically by the lifting of the slides. The length of the slots thus determines the length of the threads on the upper end of the staybolt. The length of the threads at the lower end of the bolt is determined by the height of the offset in the control bars. This may be adjusted by moving the bars vertically in their supporting lugs, the ends of the bars being threaded for that purpose.

### ACME ENCLOSED GROOVE CURTAIN FIXTURES

The Acme Supply Company, Chicago, Ill., has recently placed on the market a new curtain fixture, the interesting feature of which is the arrangement preventing the curtain from being accidentally removed from its groove. This is accomplished by placing a retaining strip over the groove, as shown in the illustrations. Metal shoes on the fixture at the bottom of the curtain are provided with flanges, which

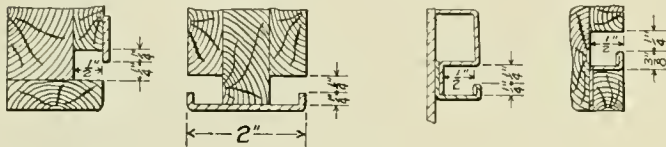

Style No 1      Style No 2      Style No 3      Style No 4  
Styles of Groove Construction

are held in contact with the retaining strip by springs located inside the fixture tube. No pinch handles are required to operate the curtain, and it can be raised or lowered from any point along the bottom. It automatically retains its alignment in the horizontal position and the fixture stays inside the groove where it belongs. The springs in the fixture tube cause the flange on the metal shoe to clutch the retaining strip firmly enough to prevent the creeping of the

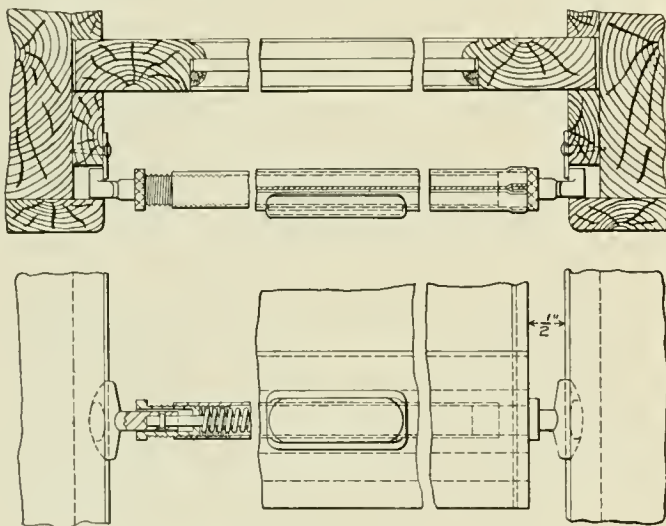

Acme Enclosed Groove Curtain Fixture

curtain under any service conditions. The groove recommended for the use with this fixture is shown in Style 1. It is 1/2-in. wide by 1/2-in. deep, with an opening 5/16-in. wide. Special fixtures, however, can be furnished which will operate in grooves 3/8-in. by 3/8-in., but the 1/2-in. width is preferable. There are four styles of grooves illustrated to accommodate the various types of car construction. The fixture can be adjusted for proper tension without removing the curtain from the groove.

### THE ROBINSON TRAIN LINE CONNECTOR

The illustrations show the Robinson automatic connector for both freight and passenger train lines as it is now manufactured after several years of development, by the Robinson Connector Company, Branford, Conn. A number of these connectors have been in use on the Canadian Northern for several years, where they are said to have met the conditions imposed by the severity of the climate obtaining in

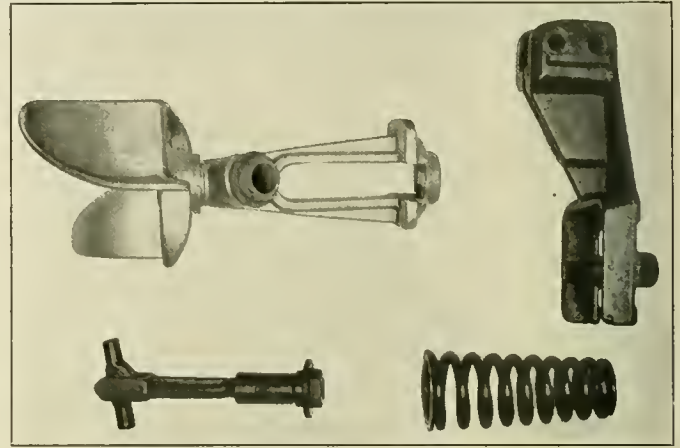

Details of the Robinson Connector

the territory through which that line operates, and their use is being extended.

Referring to the photograph of the parts, it will be seen that the connector is made up of but five pieces; the head, the spring, the bolt, the pivot bar and the arm which supports the connector from the coupler head. In assembling, the bolt, with the pivot bar in place, is first passed through the hole in the end of the head, the ends of the pivot bar being provided for by the longitudinal opening through the

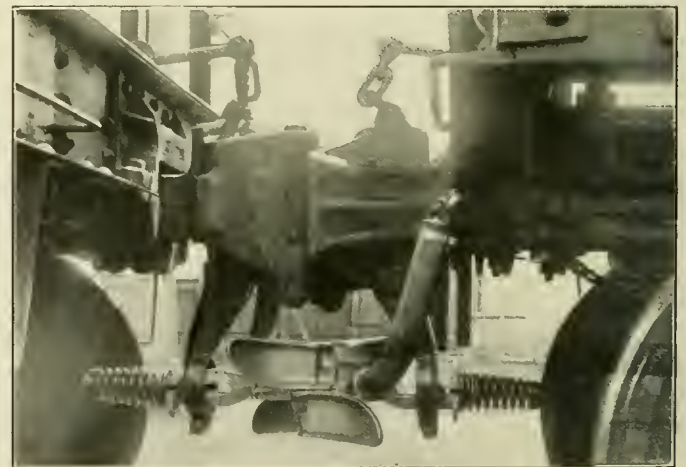

The Operation of the Freight Car Connector

shank of the head. The head is then placed in the arm with the flange bearing against the rear face of the jaws and the ends of the pivot bar seated in pockets in the jaws. When the spring is placed on the bolt, the whole device is held securely in place, the front end of the spring bearing against the end of the head and the rear end against a collar on the end of the bolt. It will be seen that the tension of the spring presses the flange of the head securely against the face of the arm and thus normally supports the head in a horizontal position.

The supporting arm is bolted to a lug on the under side of the coupler head. This lug may be gas-welded to existing couplers while on new ones it may be cast integral. When

attached to the coupler the gaskets in the contact face of head should be from 1½-in. to 2-in. ahead of the inside face of the coupler knuckle when closed, this being the amount of compression to which the connector spring is subjected when the cars are coupled. The spring is designed to produce a pressure of about 600 lb. per inch of compression, the force holding the connectors together, therefore, being about 900 lb. to 1,200 lb.

One of the illustrations shows the position of the heads when the cars are coupled. By the compression of the springs the flanges at the rear ends of the heads have been moved back from the face of the supporting arms, thereby providing for complete angular flexibility of the two heads, acting as a unit. The only resistance to angular movement is the slight friction between the bolt and the pivot bar and the friction at the pivot bearings of the latter. As this never amounts to more than a few pounds while the vertical faces of the heads are held together by 900 lb. direct pressure, it is impossible for them to be separated by any movement between the adjoining coupler heads, either vertical or angular.

The operation of the gathering arms will be clearly understood from the illustrations. They are designed to insure the positive action of the device under all conditions of service, operating without difficulty on curves up to 34 deg. and with variations of 4 in. in the height of the opposed couplers.

The hose used is M. C. B. standard with the exception of

coupling is then inserted, a spring latch being provided on the latter to prevent accidental disconnection.

The connector head is designed for use with a single hose connection on freight equipment and with three connections on passenger equipment. The drawing shows the passenger car connector. The brake hose connects to the middle opening while the signal and steam hose connections are placed above and below it respectively. With the exception of the addition of connections and ports for the latter two lines, the passenger equipment is practically the same as that for freight cars. Standard M. C. B. gaskets are used in the signal and brake ports while special rubber gaskets with high heat resisting properties are used in the steam ports. All are easily inserted or removed.

The passenger car connectors have a total weight of 40 lb., while the weight of the freight connector is 35 lb. With the exception of the spring, the parts are all malleable iron castings, the head being galvanized to prevent corrosion.

### THE "GUN" TAP

On page 429 of the August, 1916, issue of the *Railway Mechanical Engineer* there was published a description of the "Gun" tap, manufactured by the Greenfield Tap & Die Corporation, Greenfield, Mass. We are informed by the manufacturers that the statement that this tap gets its name from the fact that it was originally designed for use in gun

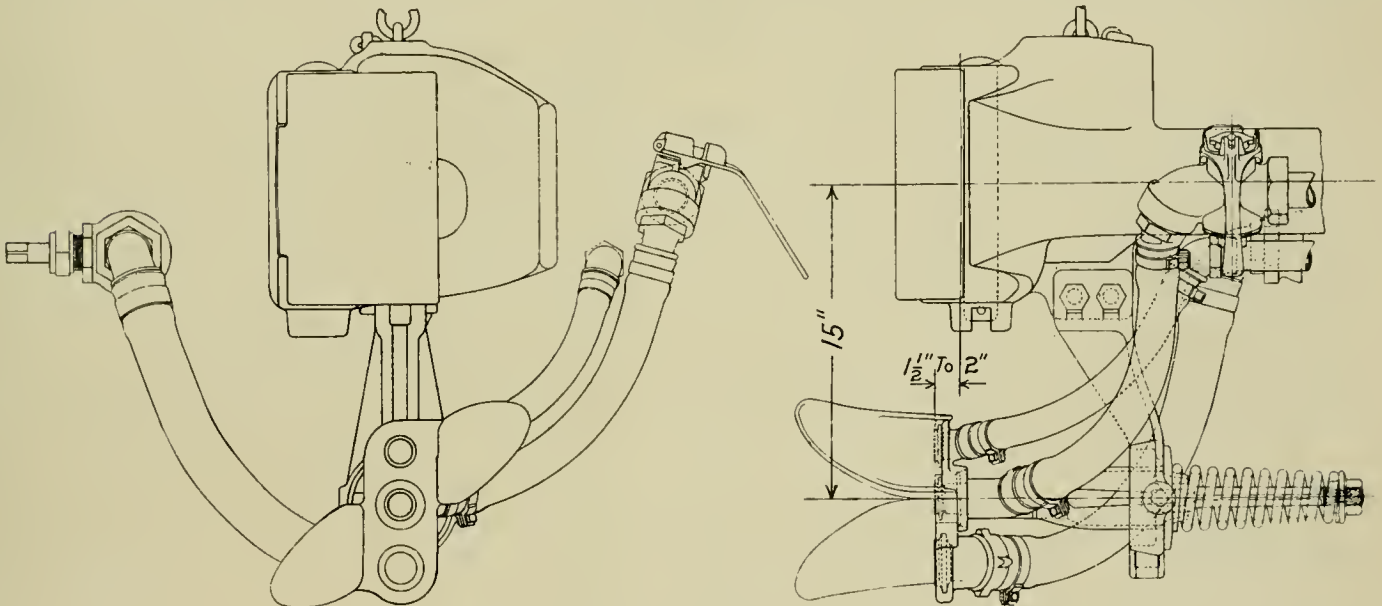

The Passenger Connector Attached to the Coupler

the length of the steam and signal hose, these being somewhat shorter than the standard. The signal and brake hose are coupled to the connector head by a union of the bayonet joint type, which requires but a quarter turn to the right or left to couple or disconnect. The hose end of this union is fitted with a special type of gasket which tends to tighten under pressure and insures freedom from leakage at this point. The steam hose is coupled to the connection by a threaded union which is easily disconnected with a wrench or hammer. Special interchange couplings are provided for use in making connections with cars not equipped with the Robinson connector. These consist of short sections of metal tubing, to one end of which is threaded a hose coupling of the standard type and on the other end of which is provided a bayonet coupling to fit the socket on the end of the hose in the case of the signal and brake hose, and a threaded union in the case of the steam hose. The hose is first disconnected from the connector head and the interchange

work, is incorrect. The tap is so called because of the fact that the shearing action of the cutting teeth deflects the chips and throws them straight ahead of the tap in long unbroken curls. This action gave rise to the name.

**CEMENT FOR STEAM PIPES.**—Cement of specially valuable properties for steam pipes and for filling up small leaks such as blow-holes in a casting, without the necessity of removing the injured pieces, is composed of 5 parts by weight of paris white, 5 of yellow ocher, 10 of litharge, 5 of red lead and 4 of black oxide manganese, these various materials being mixed with great thoroughness, a small quantity of asbestos and boiled oil being afterward added. The composition, as thus prepared, will set hard in from two to five hours and possesses the advantage of not being subject to expansion and contraction to such an extent as to cause leakage afterward, and its efficiency in places difficult of access is important.—*Power.*

# Railway Mechanical Engineer

(Formerly the RAILWAY AGE GAZETTE, MECHANICAL EDITION  
with which the AMERICAN ENGINEER was incorporated)

PUBLISHED ON THE FIRST THURSDAY OF EVERY MONTH BY THE  
SIMMONS-BOARDMAN PUBLISHING COMPANY

EDWARD A. SIMMONS, *President*                      L. B. SHERMAN, *Vice-President*  
HENRY LEE, *Vice-President and Treasurer*      M. H. WIUM, *Secretary*  
WOOLWORTH BUILDING, NEW YORK, N. Y.  
F. H. THOMPSON, *Business Manager*, CHICAGO.

Chicago: Transportation Bldg.                      Cleveland: Citizens' Bldg.  
London: Queen Anne's Chambers, Westminster.

ROY V. WRIGHT, *Editor*  
A. C. LOOON, *Managing Editor*  
R. E. THAYER, *Associate Editor*                      C. B. PECK, *Associate Editor*

Entered at the Post Office at New York, N. Y., as mail matter of the second class.

Subscriptions, including the eight daily editions of the *Railway Age Gazette* published in June in connection with the annual conventions of the Master Car Builders' and American Railway Master Mechanics' Associations, payable in advance and postage free: United States, Canada and Mexico, \$2.00 a year; Foreign Countries (excepting daily editions), \$3.00 a year; Single Copy, 20 cents.

WE GUARANTEE, that of this issue 9,100 copies were printed: that of these 9,100 copies, 7,213 were mailed to regular paid subscribers, 108 were provided for counter and news companies' sales, 485 were mailed to advertisers, exchanges and correspondents, and 1,294 were provided for new subscriptions, samples, copies lost in the mail and office use: that the total copies printed this year to date were 74,300, an average of 8,255 copies a month.

The RAILWAY MECHANICAL ENGINEER is a member of the Audit Bureau of Circulations.

VOLUME 90

SEPTEMBER, 1916

NUMBER 9

## CONTENTS

### EDITORIALS:

Strike Hastens Publication.....	439
An Opportunity for Boosters.....	439
Clearance Diagrams for Passenger Cars.....	439
Fuel Economy vs. Boiler Maintenance.....	439
Railroad Clubs Falling Down.....	439
Locomotive Boiler Efficiency.....	440
Hot Boxes on Freight Cars.....	440
Passenger Car Windows.....	440
The Successful Officer.....	440
An Important Car Department Convention.....	441
New Books.....	441

### COMMUNICATIONS:

Combined Automatic and Straight Air on French Passenger Equip- ment.....	442
The "J. C. C. Detector".....	442
The M. C. B. Book of Rules.....	442

### GENERAL:

Locomotive Boiler Efficiency.....	443
Garratt Type Locomotives for Brazil.....	448
Preparedness—The Human Element.....	449
A Question of Promotion.....	450

### CAR DEPARTMENT:

The Car Inspector and His Job.....	451
Special Tools for the Car Department.....	452
Problems of the Car Department.....	453
Special Tools for Steel Car Repairs.....	456

Suggestions for the Car Designer.....	456
Erie Railroad 50-Ton Hopper Cars.....	457
Method of Packing Journal Boxes.....	459
Steeper End Slopes for Hopper Cars.....	459
The Readjusting of Yard Inspection Forces.....	460
Co-operation in Designing Cars.....	460
Water Coolers for Passenger Cars.....	460

### SHOP PRACTICE:

Finishing Air Pump Packing Rings.....	461
Enginehouse Methods.....	461
Rabbiting Crossheads.....	462
Prevention of Boiler Corrosion by Electricity.....	462
The Master Blacksmiths' Convention.....	463
Enginehouse Organization.....	469
Railway Tool Foremen's Association.....	470
Portable Air Hoist.....	480

### NEW DEVICES:

Adjustable Dethreading Attachment for Staybolt Machines.....	481
Acme Enclosed Groove Curtain Fixtures.....	482
The Robinson Train Line Connector.....	482
The "Gun" Tap.....	483

### NEWS DEPARTMENT:

Notes.....	484
Meetings and Conventions.....	486
Personals.....	487
New Shops.....	488
Supply Trade Notes.....	489
Catalogues.....	491

The Chicago & Alton has made an increase of 1½ cents an hour in the wages of its car shop employees.

In a fire at Boston, July 25, the Boston & Maine lost a dining car and seven day coaches; estimated total loss \$25,000.

The president of Cuba has signed a bill providing for a commission to study the question of government ownership of railroads in Cuba.

One of the scale-testing cars of the United States Bureau of Standards has been testing track scales used by the railroads and industries around Chicago.

The Southern Pacific has 105 dining cars, 63 buffet cars, four cafe cars and one lunch car. Its dining car mileage last year was 10,832,847, and 3,207,353 persons were fed on the diners.

The Buffalo, Rochester & Pittsburgh Railway Employees' Magazine for August contains an article descriptive of a high speed locomotive with slide valves which is operating successfully on that road using high degree superheated steam. This engine has just completed 30,000 miles in difficult passenger service.

Through its safety committee the Nashville, Chattanooga & St. Louis has inaugurated a campaign against "train hopping." Within a period of two weeks recently, two boys were crippled while trying to catch rides on freight trains of this railroad. "Hopping" is usually practiced by the boys of the smaller communities. Arrests have proved only a temporary preventive, the danger seldom being realized until injury or death results, in which case a lawsuit usually follows. The central safety committee of the road has conceived the idea that a direct appeal to the parents, stating specific cases, such as the two accidents above referred to, will bring results.

The Pennsylvania Railroad, in a circular calling attention to the need of checking infantile paralysis, recommends that certificates be procured from the proper health officers for all children under sixteen years of age before buying tickets to any point. In the region of New York City and Philadelphia, additional quarantines are being constantly established, and in all directions children are likely to have their journeys cut short by the quarantine officers. The Baltimore & Ohio, whose cautionary circular to employees was issued July 10, soon after the epidemic began to spread from New York City to surrounding places, set forth in succinct fashion what is known as to the cause and the prevention of the disease, with advice as to proper hygienic measures.

The Baltimore & Ohio, to aid in the Ohio state campaign to protect citizens engaged in industrial employment against accidents, has notified Victor T. Noonan, director of safety of the Ohio Industrial Commission that it will tender the use of a passenger coach and will arrange for its transportation. The car will be fitted up with exhibits showing what the manufacturing and industrial concerns are doing to provide for the safety of their workmen. In the windows of the car there will be shown a series of transparency views illustrating some of the things that have been done by this road in the interest of "safety first." It is planned to have the car cover the state, visiting numerous localities which were not reached by the train recently run by the Federal government.

The government egg car is touring Indiana. This car, in which the United States Department of Agriculture educates the farmers in egg candling, packing and chilling, has just completed a tour over the lines of the Chicago, Indianapolis & Louisville in Indiana. The demonstration car is in itself a complete refrigerating plant on wheels, with its own gasoline engine for operating the refrigerating blowers, which in the course of half an hour can lower the temperature of the cold room to 32 deg. By the aid of models, shippers and railroad men are shown methods of stowing cases in cars so as to minimize damage in transit. Nine per cent of the eggs shipped to New York City alone are now cracked or mashed on the road, an enormous waste which raises the price to the consumer without benefiting the producer in any way. The government has carried out elaborate tests of different methods of stowing, and those that have been found most successful are discussed by the experts in charge. Information is given on the dressing, grading, pre-cooling and packing of poultry.

**Cars and Locomotives Ordered in August**

The August orders for cars and locomotives showed a considerable increase over the low figures for July. The totals were as follows:

	Locomotives	Freight Cars	Passenger Cars
Domestic .....	41	3,743	73
Foreign .....	135	....	15
Totals .....	176	3,743	88

The foreign orders for locomotives, it will be noticed, were over three times as great in point of numbers as the domestic orders. The foreign orders included among others the following: British Government, 45 narrow-gauge locomotives, Baldwin Locomotive Works; Italian State Railways, 60 Consolidation locomotives, American Locomotive Company; and the Northern Railway of Spain, 15 locomotives, American Locomotive Company.

The larger portion of the freight cars ordered were ordered by the New York Central, that road having given orders to the Haskell & Barker Car Company and the American Car & Foundry Company for 1,000 box cars each, and the Standard Steel Car Company for 1,000 gondola cars.

The largest passenger car order was that placed by the New York, New Haven & Hartford, which company authorized the Osgood-Bradley Car Company to proceed with the construction of 60 all-steel coaches.

**Real Safety First**

Under the date of August 15, E. E. Calvin, president of the Union Pacific, sent the following letter to the employees of the company, emphasizing the importance of the personal element to the success of the safety first movement:

"Safety First implies not alone the elimination of unsafe physical conditions; its attributes are manifold. It is the very eminence of those correlated principles, Responsibility, Sobriety, Morality, Loyalty, Courtesy and Honesty.

"Responsibility: Satisfy yourself that you realize the responsibility which rests upon you personally, and that it is fully and faithfully discharged.

"Sobriety is demanded overwhelmingly on every hand; no one in the railroad world can disregard it.

"Morality is essential to Safety, an attribute that is being required ever more constantly.

"Loyalty is indispensable to your success, and its observance will achieve much for the work you are engaged in.

"Courtesy costs you nothing but a little painstaking effort to make it an element of your character; it can be shown without intrusiveness. There is no better investment for an employee or employer, and certainly nothing else so satisfactory to the public.

"Honesty, not alone in your finances, but in every effort or endeavor. Be honest with yourself.

"Your unflinching interest in Safety First is earnestly urged, in the hope that by united vigilance and concentrated effort this property will not only maintain its present high standard, but may stand pre-eminently in the foreground at all times in the future."

**Railway Strike Ordered for September 4**

The scene of activity in the railway wage controversy and the efforts to avert a nation-wide strike of train service employees was transferred to Congress on Tuesday, August 29, when President Wilson went before a joint session of the Senate and House and asked the enactment of legislation not only for the purpose of relieving the present situation, but also as a remedy against the recurrence of similar problems.

This action was taken after the railway executives who had been in Washington for over a week conferring with the President had declined to accept the President's plan that they concede the eight-hour basic day without arbitration, but had offered a counter-proposal providing for an investigation of the questions involved by a special commission, and after the brotherhoods had practically terminated the negotiations without warning by issuing an order calling a strike for the morning of Monday, September 4, Labor Day.

Shortly after the President had presented his message to Congress most of the railway executives who had been in Washington left the city to return to their properties to make preparations for a strike if it should come.

In his address to Congress, President Wilson recommended the following legislation:

Provision for the enlargement and administrative reorganization of the Interstate Commerce Commission.

The establishment of an eight-hour day as the legal basis for both work and wages for railway employees in Interstate commerce. The authorization of the appointment of a special commission to study the results in experience of an eight-hour day, its effect on operating costs and in other aspects, to report to Congress without recommendation.

Approval by Congress of the consideration by the Interstate Commerce Commission of an increase in freight rates to meet the additional expense should the facts justify the increase.

A provision for a public investigation before a strike or lockout may lawfully be attempted.

Lodgment in the hands of the President of power, in case of military necessity, to take control of the railways and to draft into service such train crews and officials as may be required.

In asking for this legislation the President also took occasion to make a public explanation of his course in the controversy.

**MEETINGS AND CONVENTIONS**

*Traveling Engineers' Association.*—W. O. Thompson secretary of the Traveling Engineers' Association, has sent out the following circular to all members: "On account of the serious labor conditions that are now in progress with the four Brotherhoods, your executive committee has deemed it wise to postpone the annual convention until a later date. You will be advised in ample time as to what the new date will be."

*Master Car and Locomotive Painters' Association.*—The next annual convention of the Master Car and Locomotive Painters' Association will be held at Atlantic City, N. J., September 12-14, 1916. The list of subjects to be presented is as follows: The Initial Treatment and Maintenance of Steel Passenger Equipment Roofs, etc.; Headlinings Painted White or in Very Light Shades—How Should They Be Treated and Should They Be Varnished? Is It Economy to Purchase Paints Made on Railroad Specifications; The Shopping of Passenger Cars for Classified Repairs; Railway Legislation and Its Effect on Business.

The following questions will also be discussed: To what extent is it necessary to remove trimmings from passenger car equipment undergoing paint shop treatment? How does the hot water and oil method of cleaning locomotives at round-houses affect the painted parts? Is there any advantage in painting or oiling the interior of new or old steel gondola and hopper cars? Is there anything superior to varnish remover for removing paint from a steel passenger car, considering labor and material costs? Is there anything superior to soap for the cleaning of passenger equipment cars preparatory to painting and varnishing?

*Chief Interchange Car Inspectors' and Car Foremen's Association.*—The Chief Interchange Car Inspectors' and Car Foremen's Association will hold its annual convention at Indianapolis, Ind., October 3, 4 and 5, 1916. In addition to a very thorough discussion of the Master Car Builders' Rules and the changes made therein at the June convention of the Master Car Builders' Association, for the purpose of arriving at a uniform interpretation and thereby accelerating the movement of cars through the various interchange points throughout the country, it is anticipated that a number of papers will be read dealing with the subjects of passenger and freight car maintenance, M. C. B. billing, interchange inspection, etc. At this convention will also be decided the winners of the \$50 prize offered for the three best papers on Car Department Apprenticeship, these prizes to be awarded \$25, \$15 and \$10, respectively. The committee on the above subject is composed of: W. T. Westall, chairman, New York Central, Collinwood, O.; W. K. Carr, Norfolk & Western, Roanoke, Va.; C. N.

Swanson, Atchison, Topeka & Santa Fe, Topeka, Kan.; J. H. Douglas, Wheeling & Lake Erie, Toledo, Ohio, and B. F. Patram, Southern Railway, S. Richmond, Va.

The committee on Freight Car Maintenance is composed of: I. J. Justus, chairman, H. H. Harvey, J. J. Gainey, J. H. Gimple and E. S. Barstow. Papers on this subject will be read by Messrs. Justus, Harvey and Gainey.

There is also a committee on Advanced Methods of Freight Car Repair Billing, and papers on this subject will be read by J. V. Berg, chief M. C. B. clerk, New York Central, Cleveland, O.; L. H. Retan, chief M. C. B. clerk, Ann Arbor Railroad, Owosso, Mich., and F. A. Eyman, chief clerk to superintendent motive power, Elgin, Joliet & Eastern, Joliet, Ill.

Several papers will be read bearing upon the question of Interchange Inspection, the contributors being H. Boutet, chief interchange inspector, Cincinnati, O.; F. T. Rice, chief interchange inspector, Fort Worth, Tex., and A. R. Denney, chief interchange inspector, Binghamton, N. Y.

There will also be papers read on the subject of Passenger Car Cleaning and Sanitation by J. R. Schrader, E. P. Marsh, C. B. Fryer and F. M. Combs.

The association now has a membership of about 500 general foremen, car foremen and interchange inspectors throughout the country and it is anticipated that the constitution and by-laws will be amended so as to admit to membership car inspectors, M. C. B. bill clerks, or anyone actively engaged in the work of the car department.

*The following list gives names of secretaries, dates of next or regular meetings and places of meeting of mechanical associations:*

- AIR BRAKE ASSOCIATION.—F. M. Nellis, Room 3014, 165 Broadway, New York City.
- AMERICAN RAILROAD MASTER TINNERS', COPPERSMITHS' AND PIPEFITTERS' ASSOCIATION.—O. E. Schlink, 485 W. Fifth St., Peru, Ind.
- AMERICAN RAILWAY MASTER MECHANICS' ASSOCIATION.—J. W. Taylor, Karpen Building, Chicago.
- AMERICAN RAILWAY TOOL, FOREMEN'S ASSOCIATION.—Owen D. Kinsey, Illinois, Central, Chicago.
- AMERICAN SOCIETY FOR TESTING MATERIALS.—Prof. E. Marburg, University of Pennsylvania, Philadelphia, Pa.
- AMERICAN SOCIETY OF MECHANICAL ENGINEERS.—Calvin W. Rice, 29 W. Thirty-ninth St., New York.
- ASSOCIATION OF RAILWAY ELECTRICAL ENGINEERS.—Joseph A. Andreuccetti, C. & N. W., Room 411, C. & N. W. Station, Chicago.
- CAR FOREMEN'S ASSOCIATION OF CHICAGO.—Aaron Kline, 841 Lawlor Ave., Chicago. Second Monday in month, except June, July and August, Hotel La Salle, Chicago.
- CHIEF INTERCHANGE CAR INSPECTORS' AND CAR FOREMEN'S ASSOCIATION.—W. R. McMunn, New York Central, Albany, N. Y. Convention, October 3-5, Indianapolis, Ind.
- INTERNATIONAL RAILROAD MASTER BLACKSMITHS' ASSOCIATION.—A. L. Woodworth, C., H. & D., Lima, Ohio.
- INTERNATIONAL RAILWAY FUEL ASSOCIATION.—J. G. Crawford, 547 W. Jackson Blvd., Chicago. Convention, May, 1917, Chicago.
- INTERNATIONAL RAILWAY GENERAL FOREMEN'S ASSOCIATION.—William Hall, 1126 W. Broadway, Winona, Minn.
- MASTER BOILER MAKERS' ASSOCIATION.—Harry D. Vought, 95 Liberty St., New York.
- MASTER CAR BUILDERS' ASSOCIATION.—J. W. Taylor, Karpen Building, Chicago.
- MASTER CAR AND LOCOMOTIVE PAINTERS' ASSOCIATION OF U. S. AND CANADA.—A. P. Dane, B. & N., Reading, Mass. Convention, September 12-14, 1916, "The Breakers," Atlantic City, N. J.
- NIAGARA FRONTIER CAR MEN'S ASSOCIATION.—E. N. Frankenberger, 623 Brisbane Building, Buffalo, N. Y. Meetings, third Wednesday in month, New York Telephone Bldg., Buffalo, N. Y.
- RAILWAY STOREKEEPERS' ASSOCIATION.—J. P. Murphy, Box C, Collinwood, Ohio.
- TRAVELING ENGINEERS' ASSOCIATION.—W. O. Thompson, N. Y. C. R. R., Cleveland, Ohio. Convention was to have been held September 5-8, 1917, Hotel Sherman, Chicago. Postponed.

**RAILROAD CLUB MEETINGS**

Club.	Next Meeting	Title of Paper	Author	Secretary	Address
Canadian .....	Sept. 12	Railway Scrap and Salvage.....	E. J. McVeigh...	James Powell .....	St. Lambert, Que.
Central .....	Sept. 8	Train Rules and Train Disp.; Annual Outing	John F. Mackie..	Harry D. Vought..	95 Liberty St., New York.
Cincinnati .....	Sept. 12	System of Railroad Accounting.....	J. T. Leary.....	H. Boutet .....	101 Carew Bldg., Cincinnati, O.
New England.....	.....	.....	.....	Wm. Cade, Jr.....	683 Atlantic Ave., Boston, Mass.
New York.....	Sept. 17	Railway Clubs and Young Men.....	.....	Harry D. Vought..	95 Liberty St., New York.
Pittsburgh .....	Sept. 22	.....	G. M. Basford....	J. B. Anderson....	207 Penn Station, Pittsburgh, Pa.
Richmond .....	Sept. 11	Hudson & Manhattan Subaqueous Tunnel System	.....	F. O. Robinson....	C. & O. Railway, Richmond, Va.
St. Louis .....	Sept. 8	To Be Selected by Speakers; Entertainment	Executives of Local Lines .....	B. W. Frauenthal..	Union Station, St. Louis, Mo.
South'n & S'w'rn.....	.....	.....	.....	A. J. Merrill.....	Box 1205, Atlanta, Ga.
Western .....	.....	.....	.....	Jos. W. Taylor....	1112 Karpen Bldg, Chicago.



## PERSONAL

### GENERAL

M. J. McCARTHY, superintendent of motive power of the Baltimore & Ohio Southwestern and the Cincinnati, Hamilton & Dayton, at Cincinnati, Ohio, has had his jurisdiction extended over the western lines of the Baltimore & Ohio.

W. H. MALONE, assistant superintendent of locomotive performance of the St. Louis & San Francisco at Springfield, Mo., has been appointed superintendent of locomotive performance, succeeding P. O. Wood, promoted.

J. A. COOPER, supervisor of locomotive service of the Erie at Huntington, Ind., has been appointed inspector of locomotive service, with headquarters at Youngstown, Ohio.

V. B. RANDOLPH, assistant to superintendent of the Erie at Susquehanna, Pa., has been appointed inspector of locomotive service, with headquarters at New York.

C. W. WARNER, assistant general foreman of the Erie at Dunmore, Pa., has been appointed general foreman at that point.

P. O. WOOD, superintendent of locomotive performance of the St. Louis & San Francisco, has been appointed assistant general superintendent of motive power of that road with headquarters at Springfield, Mo.

### MASTER MECHANICS AND ROAD FOREMEN OF ENGINES

A. R. BALDWIN has been appointed master mechanic of the Anthony & Northern, with headquarters at Pratt, Kan. Mr. Baldwin was born at Asheville, N. C., in September,

1874, and began railway service with the Ft. Worth & Denver in 1900, remaining in its employ until 1903, when he entered the service of the Chicago, Rock Island & Pacific. For the past 15 years he has been with the latter company as general foreman of shops at Dalhart, Tex.; Pratt, Kan., and Herington, Kan. His appointment became effective August 15.

G. W. CUYLER has been appointed master mechanic of the St. Louis and Kansas City

terminal divisions of the Chicago, Rock Island & Pacific at Armourdale, Kan., succeeding R. J. McQuade, transferred.

H. CLEWER, whose appointment as master mechanic of the Chicago, Rock Island & Pacific at Trenton, Mo., was announced in the August issue of the *Railway Mechanical Engineer*, was born March 30, 1874, and educated in the public and high schools of Jackson and Athens, Ohio. He entered railway service in 1890 with the Kansas, Ocala & Southern. After serving some time as engine watchman, machinist helper, foreman and engineman with this road he went to the Chicago & Alton as an engineman and later held the positions of road foreman and master mechanic. In May, 1901, he went to the Rock Island as an engineman and with that road has held the positions of general foreman, superintendent of locomotive operation and engineer of fuel economy. He held the latter position at the time of his appointment as master mechanic.

A. E. DALES, district master mechanic of the Canadian Pacific at Brandon, Man., has been transferred to the Fourth district at Edmonton, Alta., succeeding A. West, transferred to Brandon.

I. H. DRAKE has been appointed master mechanic of the Atchison, Topeka & Santa Fe at Clovis, New Mexico, succeeding H. Schaefer.

W. R. ELMORE has been appointed acting master mechanic of the Nevada Northern at East Ely, Nevada, succeeding H. Selfridge, resigned.

A. K. GALLOWAY, master mechanic of the Baltimore & Ohio at Baltimore, Md., has been appointed general master mechanic of the northwest district and the Cincinnati, Hamilton & Dayton.

H. E. GREENWOOD, master mechanic of the Baltimore & Ohio Southwestern at Seymour, Ind., has been made master mechanic at Chillicothe, Ohio, succeeding P. H. Reeves.

W. F. HARRIS, general foreman of the Baltimore & Ohio Southwestern at Storrs, Ohio, has been appointed master mechanic at Flora, Ill.

J. HAWKINS has been appointed road foreman of engines of the Canadian Northern at Rideau Jct., Ont.

W. N. INGRAM has been appointed acting master mechanic, District 5, of the National Transcontinental at Edmundston, N. B.

A. J. IRONSIDES, formerly district master mechanic of the Canadian Pacific at Edmonton, Alta., has been appointed district master mechanic at Winnipeg, Man., succeeding G. Twist, transferred.

T. W. McCARTHY, master mechanic of the Kansas division of the Chicago, Rock Island & Pacific at Horton, Kan., has been appointed master mechanic in charge of shops at Horton.

R. J. McQUADE has been appointed master mechanic of the Kansas division of the Chicago, Rock Island & Pacific at Herington, Kan., succeeding T. W. McCarthy, transferred.

J. E. QUIGLEY, master mechanic of the Baltimore & Ohio Southwestern at Flora, Ill., has been made master mechanic at Seymour, Ind., succeeding H. E. Greenwood.

JOHN L. SMITH, JR., has been appointed master mechanic of the Pittsburg & Shawmut at Brookville, Pa.

G. TWIST, district master mechanic of the Canadian Pacific at Winnipeg, Man., has been appointed district master mechanic at Medicine Hat, Alta., succeeding A. West, transferred.

A. WEST, formerly district master mechanic of the Canadian Pacific at Medicine Hat, Alta., has been appointed district master mechanic at Edmonton, Alta., succeeding A. J. Ironsides, transferred.

THOMAS WINDLE has been appointed acting master mechanic of the Midland Valley Railway, at Muskogee, Okla., succeeding C. D. Powell, resigned.

F. C. WALLACE, general foreman of the Erie at Dunmore, Pa., has been appointed master mechanic at Avon, N. Y.

C. H. NORTON, master mechanic of the Erie at Avon, N. Y., has been transferred as master mechanic to Susquehanna, Pa.

### CAR DEPARTMENT

W. T. COUSLEY has been appointed division car foreman of the Galveston, Harrisburg & San Antonio, at El Paso, Tex., succeeding H. Allen, resigned. Mr. Cousley was formerly master car builder of the San Antonio & Aransas Pass.

JOHN H. SCHROEDER has been appointed foreman of pas-



A. R. Baldwin

senger car repairs of the Delaware, Lackawanna & Western at Kingsland, N. J. He entered the service of the Lackawanna 25 years ago as a car repairer in the Scranton freight car shops, remaining there about 4 years. He was then transferred to the passenger car department and was later made car foreman at Kingston, Pa., for a short time. He returned to the Scranton shops, and in September, 1901, was appointed freight car foreman at Secaucus, N. J., remaining in that position until his appointment to his present position at Kingsland. While at Secaucus Mr. Schroeder took an active interest in the work of the Railroad Y. M. C. A., serving as a member of the committee of management. He is at present chairman of that committee and is also a member of the Board of Education of Lyndhurst, N. J., where he resides.

#### SHOP AND ENGINEHOUSE

C. S. BLACKWELL has been appointed foreman of the Atchison, Topeka & Santa Fe at Deming, New Mexico, succeeding W. H. Kushera.

D. D. COLEMAN, general foreman of the Erie at Jersey City, N. J., Southside roundhouse, has been appointed assistant to the master mechanic at Jersey City.

A. J. DAVIS, general foreman of the Erie at Hornell, N. Y., has been appointed assistant to the master mechanic at Hornell.

E. T. DU PUE, shop superintendent of the Erie at Galion, Ohio, has been transferred to Susquehanna, Pa., in the same capacity.

L. M. GRANGER, general foreman of the Erie at Susquehanna, Pa., Outside Terminal, has been appointed general foreman of the Southside roundhouse of that road at Jersey City, N. J.

WILLIAM GRUYS has been appointed foreman of the Atchison, Topeka & Santa Fe, at Waynoka, Okla., succeeding J. J. Wagner.

H. H. HARRINGTON, shop superintendent of the Erie at Susquehanna, has been transferred to Galion, Ohio, in the same capacity.

H. A. HILLMAN, roundhouse foreman of the Erie at Cleveland, Ohio, has been appointed general foreman at Hornell, N. Y.

H. C. HUCKINS, formerly roundhouse foreman on the Chicago & Eastern Illinois, has been appointed general foreman of that road at Salem, Ill.

S. ILLINGSWORTH, formerly night locomotive foreman of the Canadian Pacific at Lambton, Ont., has been appointed locomotive foreman at MacTier, Ont., succeeding C. A. Wheeler, transferred.

A. R. PIPER has been appointed division foreman of the Atchison, Topeka & Santa Fe at San Marcial, New Mexico, succeeding A. H. Bierne.

E. P. POOLE has been appointed supervisor of tool equipment and piecework of the Baltimore & Ohio, with headquarters at Baltimore, Md., and the position of supervisor of machine and hand tools has been abolished.

T. T. RYAN has been appointed foreman of the Atchison, Topeka & Santa Fe at Las Vegas, New Mexico, succeeding T. G. Evans.

M. F. SCOTT, formerly charge hand in the erecting shop of the National Transcontinental, has been appointed foreman of the erecting shop at Transcona, Man.

C. A. WHEELER, formerly locomotive foreman of the Canadian Pacific at MacTier, Ont., has been appointed locomotive foreman at Ottawa, Ont.

#### PURCHASING AND STOREKEEPING

W. F. CASTLE has been appointed storekeeper of the San Antonio, Uvalde & Gulf, with office at North Pleasanton, Tex., succeeding G. F. Williams, resigned.

GEORGE K. RUSSELL has been appointed general storekeeper of the Pittsburg & Shawmut at Kittanning, Pa.

T. N. SOUTER has been appointed storekeeper of the Southern Pacific, with headquarters at Houston, Tex., succeeding R. L. Preis, deceased.

G. F. WILLIAMS has been appointed general storekeeper of the Midland Valley Railway, with headquarters at Muskogee, Okla.

#### OBITUARY

COLONEL WILLIAM P. CLOUGH, chairman of the board of directors of the Northern Pacific, died at his home in New York on August 18.

WILLIAM WRATTEN, who retired as district master mechanic of the Chicago, Milwaukee & St. Paul at Minneapolis, Minn., in September, 1913, died at that city on July 28.

#### NEW SHOPS

BOSTON & MAINE.—A contract is reported let by the Boston & Maine, for building a new locomotive shop at East Deerfield, Mass.

CANADIAN NORTHERN.—This company has commenced the construction of a machine shop and stores building at Edmonton, Alta. The machine shop will be a one-story structure, 61 ft. by 118 ft., with brick walls and concrete foundation. The stores building will be two stories in height, 86 ft. by 48 ft., with brick walls and concrete foundation.

CHICAGO, MILWAUKEE & ST. PAUL.—This company contemplates the construction of terminal facilities at Atkins, Iowa. The improvements will include a 26-stall roundhouse, 90-ft. turntable, 154-ft. cinder pit, a coal handling plant, a power house 50 ft. by 80 ft., a blacksmith and machine shop 50 ft. by 90 ft., a storehouse 50 ft. by 100 ft., an ice house and other buildings, as well as a modern yard for handling increased traffic.

CHICAGO, MILWAUKEE & ST. PAUL.—This company has commenced the construction of new terminal facilities at South Beloit, Ill. The work includes the construction of a three or four-stall engine house, with an 80-ft. turntable, a 43-ft. cinder pit, a coaling plant, a power house, 18 ft. by 32 ft., and a water tank.

CHICAGO, MILWAUKEE & ST. PAUL.—This company has started the construction of extensive terminal facilities including a 22-stall roundhouse, a 90-ft. turntable, a 100,000-gal. water tank, a 154-ft. cinder pit, a sand house, a coaling station, a power house, 50 ft. by 63 ft., a blacksmith and machine shop, 40 ft. by 60 ft., a car repair building, 40 ft. by 80 ft., and an entirely new yard layout, involving 15 miles of track at North McGregor, Iowa.

DULUTH & IRON RANGE.—This company has commenced the construction of a new car repair shop, one story high, 275 ft. wide and 298 ft. long at Two Harbors, Minn. The shop will be of mill building construction with steel frame, concrete block wall, concrete mastic floor and pitch and gravel roof.

ERIE RAILROAD.—This company is carrying out improvements on the County road at Secaucus, N. J. The work calls for the construction of a 36-stall roundhouse, to have 115-ft. stalls and a 100-ft. turntable, a machine shop, a power house, a storehouse and a complete engine terminal. The foundations of the buildings will be of concrete. The superstructures

of the roundhouse and machine shop will be of frame construction and the power house of tile.

**GRAND TRUNK.**—This company has started work on new repair shops at Port Huron, Mich. There will be eight buildings in the group, which are intended to accommodate 30 passenger and 75 freight cars at one time.

**LEHIGH VALLEY.**—The present inadequate engine handling facilities of the Lehigh Valley at Manchester, N. Y., will be replaced with a 30 stall roundhouse, for which contract has been let to Westinghouse, Church, Kerr & Co., New York. The company will also carry out improvements, including the construction of a new machine shop, boiler, engine and oil houses and also a 100 ft. turntable and special electrical apparatus will be provided to operate all of the machinery and light the yards.

**LEHIGH VALLEY.**—Terminal improvements are to be carried out by the Lehigh Valley at Niagara Falls, N. Y., to include a new 15-stall roundhouse, machine shop, storehouse, engine, boiler and oil house. A new car repair yard with necessary shops and storehouses will be built. The new roundhouse will be of modern type and will be of steel and reinforced concrete construction. The improvements include drop pits and a washout system for cleaning engines, a concrete and steel water ash pit, double tracked and 250 ft. long, and a concrete and steel coal pit 200 ft. long with elevated tracks. A 100 ft. turntable will also be built.

**NEW YORK, NEW HAVEN & HARTFORD.**—This company will ask for bids as soon as plans are completed for the construction of a roundhouse, also a shop and an office building at White Street yard, Danbury, Conn. The buildings are to be of frame construction with terra cotta fire wall. The roundhouse will contain eight 95-ft. stalls; the shop is to be one story high, 48 ft. by 100 ft., and the office building is to be two stories high, 42 ft. 6 in. wide by 49 ft. 8 in. long. In addition there will be a boiler and generator room, 48 ft. by 48 ft.; a storeroom, 36 ft. by 48 ft., with an oil storage system.

**OREGON SHORT LINE.**—This company will erect a five-stall addition to its roundhouse at Glenn's Ferry, Idaho.

**PENNSYLVANIA RAILROAD.**—This company will start work shortly on a 14-stall roundhouse at Derry, Pa. The structure will be of brick and wood, and will have a wood block floor, wood rolling doors and built up roofing.

**PENNSYLVANIA RAILROAD.**—This company will use its own forces to build an extension to its enginehouse at Renovo, Pa., including a small enginehouse office building. The addition will be built of concrete and brick with a timber and asphalt roof.

**MEASURING POWER OF STEAM TURBINES.**—In steam turbines, the indicator cannot be employed, as the movement of the buckets and the flow of steam are continuous. The mechanical power developed at the shaft is measured by using a friction or Prony brake or electric generators or other loads that are ascertainable.—*Power.*

**STEEL EXPORTS.**—Exports of ingots, billets and blooms, according to figures compiled by the Bureau of Statistics, have grown at such a rate that 1,000,000 tons per year have been reached. With an increase from 50,942 tons per month in the last quarter of 1915 to 84,770 tons per month for the first four months of 1916, the outgo has reached the record rate of 1,017,240 tons per year.—*American Machinist.*

**STRENGTH OF FOLLOWER BOLTS.**—Follower bolts lose their strength by crystallization caused by alternate cooling and heating and are likely to fracture when comparatively small strains are brought to bear. To be on the safe side, careful engineers make a practice of renewing these bolts at certain intervals.—*Power.*

## SUPPLY TRADE NOTES

E. W. Richey has been appointed assistant to the president of the Standard Forgings Company, with office at Chicago, Ill.

Walter D. Thomas, for many years representative in the southeastern states for the Rodger Ballast Car Company, Chicago, died July 10.

G. A. Trube has been appointed export manager of the Westinghouse Air Brake Company and the Westinghouse Traction Brake Company at Pittsburgh, Pa.

W. H. Stocks, sales representative at Chicago for the Gold Car Heating & Lighting Company, New York, died in Chicago on August 15, following an illness of several months. Mr. Stocks had been in the service of the company for over 13 years.

The St. Louis offices of the Westinghouse Air Brake Company and Westinghouse Traction Brake Company, C. P. Cass, southwestern manager, have been removed from the Security building to Suite 1407-1415 Boatmen's Bank building, St. Louis, Mo.

Thornton Hopkins, connected with the Beckwith-Chandler Company, New York, manufacturers of high grade varnishes, for many years as a representative in the railway department, and subsequently as assistant secretary, died at his home in Brooklyn, N. Y., July 31.

The Elcon Company, 50 Church street, New York, announces the appointment of Wm. Wampler as eastern sales manager of the Acme Supply Company, Chicago. This appointment will in no way affect Mr. Wampler's interest and activity as vice-president and general manager of the Elcon Company.

W. Sharon Humes, formerly employed in the motive power department of the Pennsylvania at Altoona, Pa., and later sales manager of the General Railway Supply Company at Chicago, has become associated with the Hewitt Company, Chicago, in the manufacture and sale of anti-friction metals and locomotive packing.

A. C. Garrison has been elected president of the Corrugated Bar Company, St. Louis, Mo., to succeed his father, D. E. Garrison, deceased. A. L. Johnson has been appointed vice-president and general manager, and W. H. Kennedy, vice-president and treasurer. W. M. Armstrong, vice-president and sales manager, has resigned.

Frank J. Engel, recently with the Boston & Albany, and Herman P. Hevenor, recently with the New York, New Haven & Hartford, and previously with the Brooklyn Rapid Transit, have formed a copartnership for carrying on an engineering and contracting business, operating under the firm name of Engel & Havenor, with officers at 220 Broadway, New York.

The Acme Supply Company, Chicago, announces the opening of its own offices in eastern and southeastern territory. William M. Wampler has been appointed eastern sales manager, and Franklin M. Nicholl, eastern and Canadian sales representative, with headquarters at 50 Church street, New York City. F. N. Grigg has been appointed southeastern sales manager, with headquarters in the Virginia Railway & Power building, Richmond, Va. E. S. Sullivan has been appointed sales representative, with headquarters at the Monadnock building, San Francisco, Cal.; W. F. McKenney, sales representative, with headquarters at 54 First street, Portland, Ore., and Bell & Jamison, sales representatives, with headquarters in the Hellman building, Los Angeles, Cal.

Harry M. Evans has been appointed assistant western sales manager of the Franklin Railway Supply Company, with office in the McCormick building, Chicago. Mr. Evans was born at Meadville, Pa., and was educated in the public schools at that place. He began railroad work as a call boy on the Erie, and served in various positions in the mechanical, transportation and traffic departments of that road. He entered the mechanical department of the Franklin Railway Supply Company October 1, 1908, as traveling representative, which position he held until his recent promotion to the sales department, as noted above.

Charles M. Terry, Inc., of Sydney, Australia, announces that it has secured the services of C. M. Barron as consulting and purchasing engineer, to be located in the company's offices, 23 Beaver street, New York. Mr. Barron has for the past five years exerted his efforts studying and cultivating the Australasian market for railway supplies, machine tools and raw materials.

#### Harrison Railways Specialties Company

The Harrison Railways Specialties Company, incorporated in the state of Ohio, has acquired by purchase the business and good will of the Harrison Dust Guard Company, Toledo, Ohio, formerly owned by Frank B. Harrison, who has severed his connection with the organization. The head executive office of the new company will be at Sandusky, Ohio, and the general sales office at 628-629 McCormick building, Chicago, Ill. Among the devices manufactured by the company are dust guards, journal boxes, car journal lubricators, locomotive cellars, locomotive cellar lubricators. The officers of the new company are as follows:

J. J. Dauch, president; Sidney Frohman, vice-president; W. N. Thornburgh, vice-president and general manager; Frank Kennison, treasurer, and W. P. Rude, secretary and assistant treasurer. Messrs. Dauch, Frohman and Rude will have headquarters at Sandusky, Ohio; Mr. Kennison at Toledo, Ohio, and Mr. Thornburgh at Chicago, Ill. J. J. Dauch is president of the Hinde & Dauch Paper Company, the Dauch Manufacturing Company and the Waycleanse Company, and a director of the Frohman Chemical Company, Sidney Frohman has been treasurer of the Hinde & Dauch Paper Company for many years. He is also president and treasurer of the Frohman Chemical Company, treasurer of the Dauch Manufacturing Company, and a

director and officer of various other corporations. Previous to entering business, Mr. Thornburgh was in the service of the Baltimore & Ohio successively as telegraph operator and chief clerk in the operating and traffic departments. Since leaving the Baltimore & Ohio he has been consecutively district manager of the Cleveland Stone Company at New York, Boston and Chicago; manager and treasurer of the Thornburgh Coupler Attachments Company, Ltd., Detroit, Mich; vice-president of the Ohio Quarries Company, Cleveland, Ohio; vice-president and general manager of the Metropolitan Engineering and Construction Company, Kansas City, Mo.; general manager of sales of the Standard Asphalt & Rubber Company, Chicago, Ill.; a member of the firm of Thornburgh & Kinnear, general contractors, Houston, Tex., and manufacturers' representative in the brick, stone and marble business at Pittsburgh, Pa. Mr. Thornburgh will have charge of the general sales office at Chicago, Ill.



W. N. Thornburgh



J. J. Dauch



S. Frohman

T. F. Flanagan, whose appointment as general sales and advertising manager of the Pyrene Manufacturing Company, New York, has already been announced in these columns, is only 25 years of age. He was educated at Trinity College in Hartford, where he was active in the management of both the college magazine and newspaper. During the same time he worked nights as a reporter on the Hartford Courant, and during the summer did police reporting. Following his graduation, Mr. Flanagan went to New York and became associated with the Wales Advertising Agency, which he left to become advertising manager of the C. J. Tagliabue Manufacturing Company, in Brooklyn. In that company, he worked rapidly into the sales department, where he directed the work of about 20 salesmen and where he remained until 14 months ago, when he joined the Pyrene Manufacturing Company as assistant advertising manager. Soon after he joined the Pyrene forces he became assistant to C. Louis Allen, now the company's president, but then its sales manager, and when Mr. Allen's promotion left the position of head of the sales force vacant the work devolved on Mr. Flanagan. Now he has been given the title of general sales and advertising manager as above noted.

J. L. Terry has become associated with the sales department of the Q & C Company, New York. Mr. Terry has been in railway supply work but a comparatively short time. He was formerly on the Denver & Rio Grande, and later purchasing agent of the Denver, Laramie & Northwestern,



T. F. Flanagan

and subsequently served as superintendent and general manager.

The Chicago office of the Ashton Valve Company, Boston, Mass., will be located in the Transportation building on and after September 1.

Walter Chur, president and general manager of the American Railway Supply Company, New York, died August 29 at his home in East Orange, N. J., after an illness of five months, of heart disease.

The Waynesboro Foundry & Machine Company, Waynesboro, Pa., is contemplating installing a new line of foundry equipment for the manufacture of a brass specialty. The company operates a brass, bronze and aluminum foundry.

The Selby Safety Flag Company, St. Louis, Mo., is in receipt of orders from the Chicago, Peoria & St. Louis, the Southwestern (Texas), and the Kansas City, Mexico & Orient, for improved flagmen's signal outfits.

W. L. Hayes, formerly assistant manager of the Cleveland, Ohio, district of the American Steel & Wire Company, has been appointed manager of the Chicago district, to succeed F. C. Gedge, deceased. W. C. Stone, formerly assistant manager of the Chicago district, has been appointed manager of the Cleveland, Ohio, district to succeed Mr. Hayes.

At the recent annual meeting of the stockholders of the United States Light & Heat Corporation, Niagara Falls, N. Y., the following board of directors were elected: Egbert H. Gold, J. Allan Smith, Ralph C. Caples, Henry W. Farnum, A. Henry Ackermann, Chauncey L. Lane, Keene H. Addington, James A. Roberts, Conrad Hubert, George G. Shepard, Edwin K. Gordon. The vote of confidence in favor of the present management was 371,079 out of 425,245 votes cast.

Edwin L. Willson, for the past five years sales engineer in charge of the railroad department of the Hazard Manufacturing Company, Wilkes-Barre, Pa., resigned on August 1 to become president of the Connecticut Electric Steel Company, Inc. Mr. Willson was born at Baltimore and received his early education in the public schools of that city. In 1905 he graduated from the Baltimore Polytechnic Institute and in 1908 graduated from Lehigh University with the degree of electrical engineer. During his school days he was engaged in railway engineering and construction work with the Westinghouse Electric & Manufacturing Company. Upon leaving school he went with the Hazard Manufacturing Company, at the Wilkes-Barre office, in charge of electrical and chemical testing. In July, 1911, he entered the sales department as sales engineer in charge of railroad work, with offices in New York City, which position he held until August 1. In his new position Mr. Willson has headquarters at 50 Church street, New York, but will shortly remove his office to Hartford, Conn., at which point the foundry is located. The plant is nearing completion and will be in operation early in October. The Connecticut Electric Steel Company, Inc., will manufacture high quality steel castings by the Heroult electric process.



E. L. Willson

## CATALOGUES

**AIR COMPRESSORS.**—Bulletin 34-N recently issued by the Chicago Pneumatic Tool Company deals with the company's steam and power driven single compressors.

**SCALES.**—The Standard Scale & Supply Company, Pittsburgh, Pa., in its recently issued price list No. A210, gives illustrations, brief descriptions and price lists of the line of Standard scales. The scales shown include a wide variety for many kinds of businesses and uses.

**STORAGE BATTERIES.**—One of the latest publications of the Electric Storage Battery Company, Philadelphia, bulletin No. 159, deals with the Ironclad-Exide battery for storage battery, mine and industrial locomotives. The booklet describes the batteries themselves and contains a score of views of storage battery locomotives.

**FOUNDRY EQUIPMENT.**—The Whiting Foundry Equipment Company, Harvey, Ill., has recently issued catalog No. 120, dealing with tumblers and dust arresters; catalog No. 121, dealing with coke oven equipment, including ovens, racks, cars, trucks and coke-oven doors, and catalog No. 122, dealing with ladles. All three bulletins are well illustrated.

**CAR WHEELS.**—The Griffin Wheel Company has issued a seven-page booklet containing nine reasons why the chilled iron car wheel is preferable to other types of wheels, as follows: safety, low initial cost, low maintenance cost, guaranteed service, brake efficiency, saving in brake shoes, saving in rail wear, minimum of flange wear and liberal allowance for old wheels.

**STRUCTURAL TIMBER.**—The National Lumber Manufacturers' Association has issued a 70-page book by C. E. Paul on heavy timber mill construction buildings. The book describes mill construction, and the manner in which it is built and gives information concerning the cost. The book should be of much value to those interested in this character of construction.

**PASSENGER CAR COUPLERS.**—The McConway & Torley Company, Pittsburgh, Pa., has recently issued a booklet dealing with its Pitt pivoted passenger coupler. The booklet describes the coupler, particular attention being given to its great flexibility in curving, and contains views of 45 passenger cars of various types, for 16 different roads, on which the Pitt coupler was specified.

**LOCOMOTIVE STOKERS.**—The Locomotive Stoker Company has recently issued catalogue 14-C, dealing with Street locomotive stoker applications. The book in its 60 pages shows the different types of locomotives to which these stokers have been applied, there being given photographs and specifications of 28 locomotives of different types built for 15 railroads. This is the fourth revision of this catalogue and brings it up to date.

**THE LOGIC OF THE DEAN.**—This is the title of a booklet which has recently been issued by the William B. Pierce Company, Buffalo, N. Y. The booklet deals with the Dean boiler tube cleaner made by the company. It shows how scale is formed and asserts that the formation of scale cannot be prevented absolutely by boiler compounds. It then takes up the problem of scale removal and describes the Dean tube cleaner and its operation. A list of users is also given.

**STEEL PIPE.**—The National Tube Company has recently issued a third edition of its catalog of National Matheson joint pipe. This is a system of piping for high or low pressure natural or artificial gas lines, water works, mines, mining, hydro-electric plants, irrigation and engineering uses. The catalogue takes up the characteristics of the pipe and shows its advantages for different kinds of service. The book is extremely well illustrated with views of typical installations of

many different kinds. One of the interesting features is a series of drawings or cartoons emphasizing some of the points that are made in the text.

**PYROMETERS.**—The Gibb Instrument Company, Pittsburgh, Pa., has issued a folder relative to the "I-Rite" for judging the temperature of metal undergoing treatment. The "I-Rite" is an instrument in appearance much like a pocket flashlight. The person using it stands some distance from the furnace, and looks through it at the object the temperature of which is to be measured. A description of it appeared in the May, 1916, *Railway Mechanical Engineer*, page 262.

**WOOD CONSTRUCTION AND FIRE LOSSES.**—The National Lumber Manufacturers' Association, Chicago, has issued a 15-page booklet pointing out some of the errors in the commonly accepted ideas regarding the large fire losses resulting from timber construction and presenting a large amount of data regarding actual accurate comparisons. This book contains a large amount of information of value to those interested in wood construction from the standpoint of the fire hazard.

**GEAR BLANKS AND MISCELLANEOUS CIRCULAR SECTIONS.**—The Carnegie Steel Company has recently issued a third edition of its booklet dealing with this subject. The booklet contains standard specifications, lists of dimensions, illustrations and drawings of forged and rolled gear blanks, industrial and mine car wheels, street and interurban railway wheels, pipe flanges and shaft couplings, automobile flywheel blanks, crane track wheel blanks and piston blanks. The piston blanks for the manufacture of solid steel locomotive pistons are illustrated for the first time.

**STEAM HAMMERS.**—The National Hoisting Engine Company, Harrison, N. J., has issued a 20-page catalog describing the National steam pile hammer. The booklet contains tables giving the dimensions and other characteristics of the five sizes of these hammers and is illustrated with photographs showing the hammers in use on various kinds of construction work. A 12-page pamphlet has also been issued describing the steam hammers No. 6 and No. 7, weighing 650 and 150 lb., respectively, which are designed especially for use in driving wood and steel sheet piling.

**COAL UNLOADER.**—The Roberts & Schaefer Company, Chicago, has issued Bulletin No. 31, which describes the "RandS" measuring coal loader for locomotives, a device which automatically measures the coal as it is being discharged into the locomotive tenders. The operation of this device is explained in detail with ample illustrations. The pamphlet also contains a description, with illustrations, of the duplex 12-ft. shallow pit loader, a new arrangement of the substructure of coaling stations which will decrease the cost of foundations for any coaling station of the bucket type.

**ON THE FIRING LINE WITH BATTERY BILL.**—The story of W. Alkaline Battery, otherwise known as Battery Bill, has now been published in booklet form by Battery Bill's employer, the Edison Storage Battery Company, Orange, N. J. Battery Bill is already well known to readers of the advertising pages of the *Railway Mechanical Engineer*. He is the enterprising salesman of Edison storage batteries whose adventures, detailed in the form of letters to his boss, center around his successful attempt to sell Edison batteries to the X. Y. Z. Railroad and to help the officers of that road answer the query of President X: "Why aren't we using Edison batteries?"

**HEATING AND VENTILATING APPARATUS FOR PASSENGER CARS.**—This is the title of a 144-page book, 9 by 12 in. in size, which has recently been issued by the Gold Car Heating & Lighting Company, New York. The book gives a complete description of the company's steam, vapor, hot water and electric systems for heating and automatically con-

trolling the temperature of all types of railway cars, and also data concerning its ventilators. The apparatus which is included in the systems is illustrated and described in detail, and drawings are given, many of them in two or more colors, showing the application of each of the various systems.

**CAR CURTAINS AND CURTAIN FIXTURES.**—The Acme Supply Company, Chicago, has issued Bulletin F-6, in which is introduced its new Acme Enclosed Groove F. P. Curtain Fixture No. 100. The interesting point in this fixture is the fact that it cannot be removed from its groove by the passengers. No pinch handles are required, and it can be operated from any point along the bottom of the curtain. Descriptions of the Crown and Gem curtain fixtures for use with open grooves, the Acme friction roller, and the special metal car curtain roller, are also contained in this bulletin as well as curtain fixtures for electric cars and interurban coaches.

**VARNISHES, ENAMELS AND JAPANS.**—The Moller & Schumann Company, Brooklyn, N. Y., has recently issued Bulletin No. 1, dealing with the company's Hilo black enamels and japans. The bulletin describes the range of blacks available for wood, steel, cast iron, tin, brass or other materials. It contains lustre standards whereby one may readily obtain a clear idea of the meaning of the terms, gloss, semi-gloss, rubber, dull rubber or flat, and be enabled to pick out the finish best suited to his needs. Each article is described in a manner to indicate its use. The bulletin also gives the necessary reduction for applying; the various methods of brushing, spraying, dipping and tumbling, and it also indicates the heat and time of baking.

**CAR WHEELS.**—The American Steel Foundries have issued an attractive catalog descriptive of the Davis steel wheels made by the company. The booklet names the advantages of the Davis one-wear steel wheel asserting that, "It retains the advantages of the cast iron wheel—a hardened tread and flange, a softer plate and hub, and a one-wear construction" and in addition is stronger, is of less weight, has absolute rotundity because of its ground treads and has a lower maintenance cost on account of fewer removals for common wheel defects. The booklet is well illustrated, there being given sections, pictures of the wheels, and a number of views, some in colors, showing the manufacture. One section deals with wheels for electric railway service and another gives comparative data of Davis and other wheels in tests and actual service.

**STANDARD SAFETY DEVICES.**—The "Conference Board on Safety and Sanitation," 928 Western avenue, West Lynn, Mass., has issued an eight-page leaflet describing the "N. A. S. O." safety devices, with illustrations and prices. These devices have been approved by the Conference Board, which represents the National Affiliated Safety Organizations, namely, the National Founders' Association, the National Association of Manufacturers, and the National Metal Trades Association; and all of the articles are made under the supervision of the board. The aim is to sell these articles at cost, or nearly so; but any profits derived from sales are utilized for further research in connection with the promotion of safety in industrial establishments. Among the things described are goggles; leggins for foundrymen; respirators; the N. A. S. O. Sanitary Stretcher; Safety Feet for Ladders, and a Metal Danger Sign.

**FRENCH METAL AND TIMBER COMMITTEE.**—By virtue of a decree dated June 11, 1916, a committee has been appointed at the French Ministry of War to centralize the acquisition of metal and timber from abroad and to distribute the material imported, together with that of French production, to the best interests of national defence. The members of the committee are taken from the various Ministries and from various military and naval corps.—*Engineering*.

# Railway Mechanical Engineer

Volume 90

October, 1916

No. 10

## Help Push Your Association

Last month we announced that prizes of \$15 each would be awarded for the three best articles of not more than 750 words received at our office in the Woolworth Building, New York, not later than November 1, 1916, setting forth the practical benefits received by the writers from their attendance at the railway mechanical department conventions. The importance of the work done by these associations is most fully realized by those members who are actively engaged in association affairs, and here is an opportunity for them to show how well their interest and belief in these institutions is justified. Such testimony can not fail to interest others who should belong to the associations, as well as the general officers upon whose support their success so largely depends. While there are but three prizes offered, we confidently expect to receive a large number of contributions nearly as good as the prize winners, which we will publish and pay for at our regular space rates. Be sure that your association is represented.

## Fuel Cost and Fuel Economy

The high price of coal, or the distance it has to be hauled, does not necessarily mean that it is the most expensive coal to buy. With the constantly increasing improvement in the art of firing locomotives and in the economical use of fuel as a whole, new conditions have developed which may warrant the use of a more expensive fuel with a saving in the actual cost of the fuel consumed. This has been found to be true on one road in the Middle West which took the trouble to investigate. One division of the road had for some time been using a low grade coal that was mined in the territory through which the division ran. Further west there was a much better grade of coal which was more expensive and had to be hauled greater distances. However, experiments were made with the result that it was decided to use the better grade of coal from the distant point in preference to the local coal of inferior quality. This has been justified, for a saving of 20 per cent has been made in the cost of fuel consumed in the particular district where this change was made.

## The Engine House and the Tool Foreman

It was a great satisfaction to hear various speakers at the Tool Foremen's Convention put in such a strong plea for the engine house forces. If there is one place in a railroad organization that needs all the assistance in the matter of good tools and special devices with which labor and repairs to locomotives may be expedited it is the engine house. The only thing a railroad has to sell is transportation. The cost of conducting this transportation is dependent on the condition and availability of the power. It is the duty of the engine house foremen to provide this power many times on sudden demand and to have it in such shape that it can handle its proper tonnage. Quick repairs are often necessary and the necessary means for making them

should be provided. The tool foreman can be of great assistance in this respect. His work requires that he devise tools and, in many cases, equipment that will expedite the making of repairs. Being located at the larger shops he naturally gives their needs his first consideration, but he should not forget the running repairs which are so necessary to good locomotive performance. Most careful study should be given to engine house requirements and he should use his ingenuity in devising ways and means for expediting its work.

## Standard Methods for Railway Shops

From the remarks of some of the tool foremen at their recent convention it appears that on several roads the interchange of ideas and of special shop devices between the various shops, even on the same road, is extremely limited. It is hard to conceive how a condition such as this should be allowed to exist. Any new device or method of performing economically a certain class of work originating at one point should be drawn up in suitable form and passed along to all the shops on the system for their immediate benefit. This is done usually by means of a book of blue prints and instructions. The Sante Fe has what is called a Locomotive Folio and a Tool Folio. The former covers standard practices—giving the scrapping limits of the various parts of the locomotive, methods of making certain repairs, etc. The latter contains a description of the standard tools and special tools that are of sufficient merit to warrant their duplication at the other shops on the system. The Locomotive Folio is in charge of the mechanical engineer and the Tool Folio is in charge of the supervisor of tools. These folios are distributed broadcast over the system and their use is enforced. As improvements develop changes are made. Any and all suggestions for improvements are given careful consideration. Every part of the road receives full benefit of the ingenuity and achievements of any one part of the road. It is only by this means that the outlying points can be kept up-to-date in the most efficient shop practices.

## Functions of the Mechanical Associations

W. J. Tollerton, in his address to the Master Blacksmiths' Convention, brought out clearly the functions of the various mechanical associations. Referring particularly to that association, he said: "It would be of enormous benefit to all railroads if this association would formulate some kind of a standardized schedule of blacksmith shop practice." This statement may well apply to all the other associations representing the various shop crafts. Several roads have already established standard shop methods in making repairs to cars and locomotives which represent the best methods known to those roads. Why not carry it further and have the various associations thoroughly study shop practices peculiar to their specific fields and form standards that will be the best established standards in existence? The associations could not use their time to better advantage. They would be performing a real service to the

roads they represent. It would be a great thing for each association to have a set of established standards and recommend practices the same as the Master Car Builders' and Master Mechanics' Associations. These could be added to and corrected year by year and be kept up to date with the development in the various fields. With the labor conditions such as they are at present anything that will increase shop efficiency will be gladly welcomed. If the mechanical associations would spend their time in establishing standard practices they would undoubtedly receive far greater support from railroads than they do now. It would be a matter of business to have a representative from every important road attend the conventions in order that the best possible results might be obtained.

#### The Microscope and Boiler Steel

Is the microscope too refined for use in connection with the selection of boiler steel? Can it be used with safety by the man who has not had years of training in its manipulation and in drawing conclusions from its indications? To both of these questions an affirmative answer can probably be made with safety. If the observer desires to determine an approximation of the carbon content of a piece of steel, it is probable that, unless he has had considerable training, he will vary so far from the true mark that he had best discard his microscope and betake himself to the chemist. But for the detection of defects in the material, such as the inclusion of slag, minute blow-holes, and variation in structure the microscope will tell a story to even a lay operator that can be told in no other way. An article in the *Railway Age Gazette* of April 28, 1916, page 960, gave a vivid example of how a piece of steel, that had passed all inspection and was presumably of a high grade, was shown by the microscope to be really unfit for the service to which it had been applied, simply because of the great variation in its structure between surface and center, that could have been detected in no other way.

The preparation of the specimens is exceedingly simple and an instrument with glasses arranged magnifying from 20 to 100 diameters will serve all the purposes of a quick and accurate means of determining the general structural character of a piece of steel or iron. It will frequently make it possible to decide at once in the choice of two brands and the probable relative results to be obtained from them. It tells a very vivid story of structure and enclosed impurities that can be read in no other way, and to those who are shown it without previous knowledge of what they are to see the indications are usually quite startling.

#### General Foremen and the Car Department

Notwithstanding the seriousness of the strike situation, the attendance at the convention of the International Railway General Foremen's Association at Chicago during the last week in August was good. It became necessary, however, to set the adjournment one day ahead, the result being that a number of the subjects were not discussed as fully as their importance and the character of the papers presented would have justified under other circumstances. It is significant, however, that the subject which brought out probably the fullest discussion of any presented, was that of car department problems. At the smaller terminals the general foreman in charge of locomotive maintenance often has direct supervision over car repair work but to a large extent the members of the association are directly concerned with locomotive work only. It is from the ranks of these men, however, that the higher mechanical department officers are usually selected; and as soon as he is promoted to the position of master mechanic, the general foreman is immediately called upon to deal with car depart-

ment matters. From the standpoint of the ambitious general foreman, therefore, it is to his own interest that he keep as closely in touch with the car department and cooperate with the car foreman to the fullest possible extent. That this is the attitude of the members of the association was well brought out in the discussion, but the interest thus displayed in the car department will be of much wider benefit than that gained by the individual. The general officers of the mechanical department are, and probably will continue to be, chosen largely from the ranks of the locomotive department. Improvements in the car department service, therefore, very largely must depend upon the broad appreciation of its problems and of the importance of the work which it performs by the future master mechanics and superintendents of motive power.

#### The Purchase of Paint On Specifications

The advisability of purchasing paint on specifications has been seriously questioned by many users of paint and there is a growing doubt as to whether the quality of the materials thus obtained is not inferior to those obtained by straightforward purchase of the guaranteed products of reputable paint manufacturers. That the experience of the manufacturers qualifies them to provide a product suitable to meet the conditions of any class of service is undoubtedly true, and that the reputation which the manufacturers have to maintain, is generally a sufficient guarantee that their products will honestly meet the conditions, is no less true. Specifications would appear to be unnecessary then, to secure a suitable product, and their principal function is to secure the product desired under competitive conditions, with the saving in price which is effected thereby. In order that a product of the quality desired may be secured under open competition, it is not only necessary that the specifications be carefully drawn and well advised, but that the purchaser be in a position to enforce their provisions. The success with which specifications may be employed where these requirements can be met, was well brought out in the remarks of Dr. M. E. McDonnell, chemist of the Pennsylvania Railroad, before the recent convention of the Master Car and Locomotive Painters' Association, the report of which appears elsewhere in this issue. But few railroads, however, are provided with the facilities available on the Pennsylvania for making the numerous tests necessary in the development and enforcement of adequate specifications, and the extent to which they can safely and successfully be employed undoubtedly depends in a large measure upon the extent to which facilities of this kind are available. Specifications employed without some such facilities tend to defeat their own end; while products may thereby be obtained at a low price, the quality will usually be such that the paint is expensive in the end.

#### Corrosion and Boiler Steel

The electrolytic theory of corrosion, as developed and proved by Dr. Allerton Cushman, so fully accounts for all the various phenomena attendant upon the corrosion of iron and steel that it is accepted throughout the scientific world. But theories of this character are too often regarded as pure theories by the practical men of affairs—something belonging to the laboratory and the domain of scientific investigation and as having little or no connection with the work of every day life, or at best to be possessed of such a refinement as to have little or no influence upon them. In short, there is a decided mental distinction drawn between the action of a piece of steel subjected to the delicate tests of a laboratory experiment and the performance of a similar piece in the rough service that it has to perform in the firebox of a locomotive. That this is a mistake, almost anyone will



concede. And because this matter of corrosion is one of the serious troubles of locomotive boiler maintenance it is urged that too much attention cannot be paid to the selection of steels that are used therein. The whole electrolytic theory of corrosion is based upon the development of electric currents by the non-homogeneous character of the metal, and the greater this variation in structure and composition the more rapid will be the corrosion. This is a simple statement of cause and effect. Hence it follows that he who would suffer the minimum of trouble from corrosion must pay the maximum of attention to the selection of his steel and iron, other conditions remaining the same. This is not to assume that the sole precaution to be taken against corrosion lies in the selection of the steel, for there is such a thing as a corrosive water, but, as Kipling would say, that is another story.

#### Proper Braking of Long Passenger Trains

The apparently increasing difficulties experienced by the railways in properly braking the long heavy passenger trains in service today is due very largely to the fact that sufficient attention has not been given to the foundation gear of the modern equipment. With the heavier steel passenger cars greater shocks result for the same difference in velocity between the front and rear cars of a train than when the lighter wooden passenger cars were used. These shocks are further increased on account of the longer trains now being handled in the present through-train service. Of course, the braking power has been increased to meet these new conditions, and the difference in time between the application of the brakes on the first car and on the last car has been decreased through quicker acting triple valves. But the adoption of the improved foundation gear has not been so general.

With the single shoe brake it is practically impossible to keep a uniform brake cylinder piston travel throughout the train, which means unequal braking of the cars with the attendant shocks throughout the train. The manner in which the shoes are located with respect to the wheels is largely responsible for this. They must be located sufficiently far below the horizontal center line of the wheel to bring the resultant pressure line of the shoe against the wheel within the journal brass. In this position the shoe has a tendency to pull down under the wheel, increasing the false travel of the brake rigging. As this travel is taken up by the automatic slack adjuster the brake cylinder piston travel becomes shortened, resulting in increased brake shoe pressure with small brake pipe reductions. This is cumulative and near the end of long runs the engineer has extreme difficulty in applying the brakes so that a smooth and quick stop can be made. He is forced to make two or three light reductions in an endeavor to obtain a smooth stop, which means that more time must be taken in making stops.

The experience of the New Haven and the Pennsylvania with the clasp brakes has shown that by their use the troubles found in handling the long heavy passenger trains with the single shoe brake have been practically eliminated. With the clasp brake less pressure per shoe is required, the shoes can be applied nearer the horizontal center line of the wheel, the truck frame will be subjected to a smaller amount of racking and displacement and there will be practically no false motion for the automatic slack adjuster to take up. This permits the slack adjuster to do the work intended for it—namely, to take up the lost motion due to the wear of the shoes. While the clasp brake has been adopted to some extent on four-wheel trucks its particular field is on the six-wheel truck cars weighing from 120,000 to 160,000 lb. Its satisfactory application requires an 11-ft. wheel base, and car designers, even though they cannot see the need of

the clasp brake to their equipment now, would do well to adopt this length of wheel base in case it becomes advisable to change to the clasp brake in the future.

#### Speed Indicators on Locomotives

The use of speed recorders on locomotives has been given but little attention in this country, and then only as applied to road engines. This is remarkable, considering the possibilities for improvement, both in operation and maintenance, which the records from these instruments open up in switching service as well as in road service. Where locomotives are shopped on a mileage basis, the usual method of computing the mileage of switch engines is by the allowance of an arbitrary number of miles for each hour the engines are in service. This is at best but an approximation, the variation of the actual mileage from which will be considerable, depending on the conditions under which the engines are working. That the discrepancy between the miles credited to the engines and the actual service rendered may be very great was brought out in the discussion of the report on Classification of Repairs at the convention of the General Foremen's Association. On the El Paso & Southwestern, where the engines were credited with 72 miles per day, after they had been equipped with speed recorders the actual mileage was found to be from two to three times this amount. It is needless to say that this condition had been a source of considerable discord, as the mechanical department foremen were expected to keep the engines in service from two to three times as long as they could reasonably be expected to run—often an impossible task.

In road service the speed recorder is a necessity where maximum speed limits are in force, but their usefulness does not end with the performance of this function. The records, which are in effect logs of the trips made by the locomotive, are a valuable source of information in settling controversies growing out of train delays, the mechanical department being relieved of the burden of proof in many cases which rightfully should be charged to the operating department. Their influence is also felt in running repairs. On the El Paso & Southwestern in the maintenance of driving boxes alone, they have effected a material saving, by insuring that the maximum speed limit specified will not be exceeded, it having been possible at one terminal to materially decrease the number of men in the drop pit gang. The possibilities in this regard may readily be seen, as inequalities in time card schedules often cause the speed required at certain points on the line to be unnecessarily high, while the running time on other portions of the line could be shortened. Inequalities of this kind are readily brought out by the records from the speed recorders, making possible the adjustment of schedules more accurately to meet the operation conditions and thereby reducing the wear and tear on the motive power. All of these benefits have actually been derived from the speed recorders where they have been in service in this country.

#### NEW BOOKS

*Proceedings of the Tenth Annual Convention of the Master Boiler Makers' Association.* 200 pages, illustrated, 6 in. by 9 in. Bound in cloth. Published by the secretary, Harry D. Vought, 95 Liberty street, New York City. Price, \$1.

This volume contains a complete transcript of the proceedings of the convention of the association, which was held at the Hotel Hollenden, Cleveland, Ohio, May 23 to May 26, 1916. The association is to be congratulated upon the short time which has elapsed between the holding of the convention and the publication of the complete proceedings in book form.

# BOILER EXPANSION EXPERIMENTS\*

Tests to Determine Relative Movements of Fire-box Sheets and Tubes Under Working Conditions

BY D. R. MAC BAIN

Superintendent Motive Power, New York Central West, Cleveland, Ohio

SOME experiments were made on the New York Central in 1910 to determine why the side sheets of certain new fireboxes would crack vertically between the staybolt holes. In one case it was found necessary to put in new sheets on a new boiler that had been in service only about four

months. Mr. Linderman, then boiler maker on the Michigan Central, conceived the idea of comparing the expansion of failed was taken for the experiment. Tram marks were made on the inner and outside sheets when the boiler was cold. The engine was then fired up and after 200 lb. pressure had been raised and the pops had been blowing for some time, the fire was quickly dumped and the measurements between the

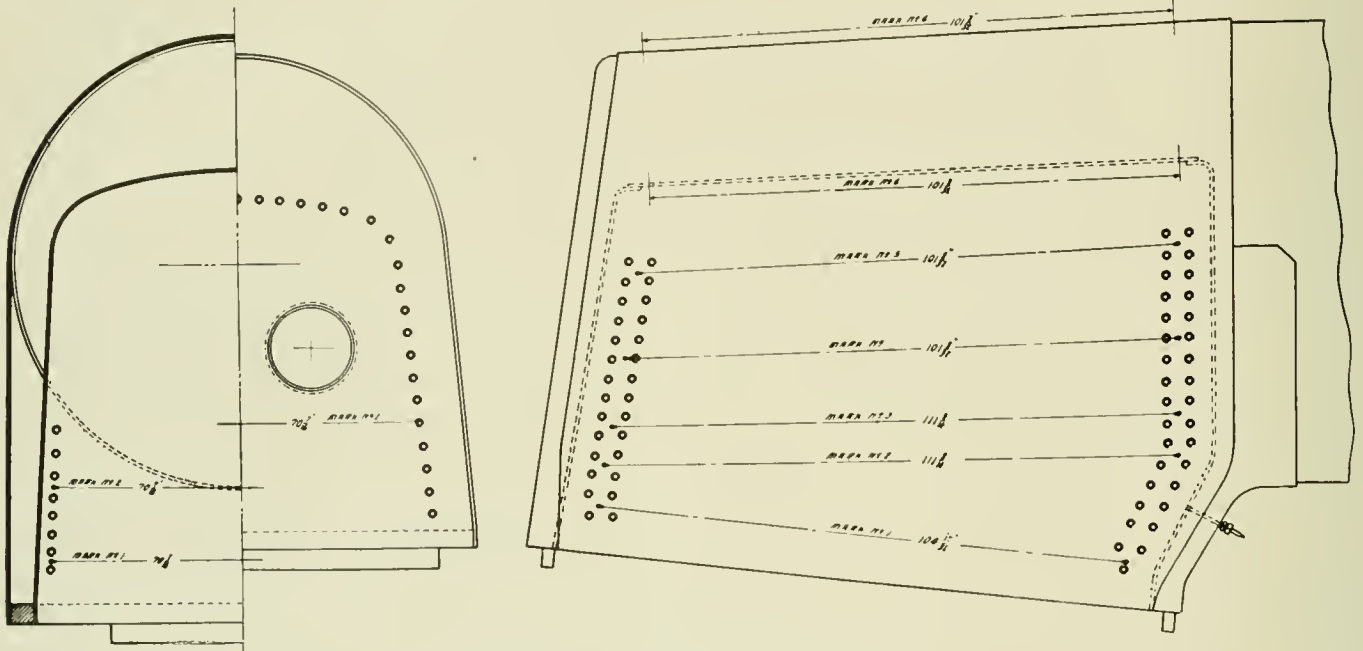

Fig. 1—Tram Marks Measured for Expansion

months. Mr. Linderman, then boiler maker on the Michigan Central, conceived the idea of comparing the expansion of

tram marks taken on both the inside and outside. It was found that the outside sheet expanded  $\frac{3}{32}$  in. more than the inside sheet.

This same experiment was again tried under more favor-

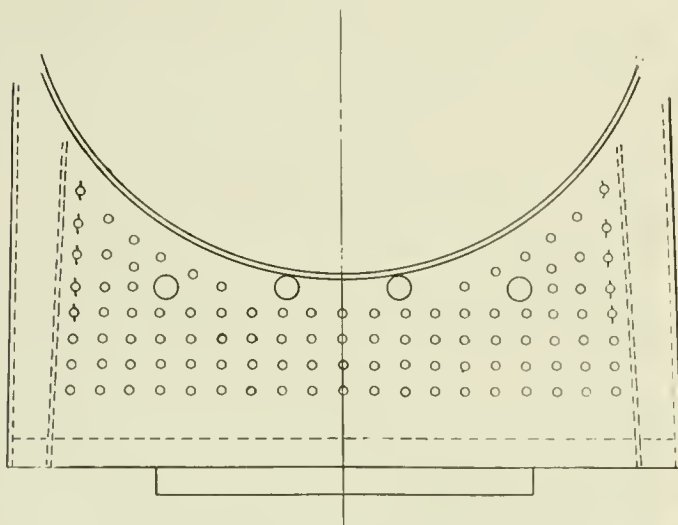

Fig. 2—Cracks Found in the Throat Sheet

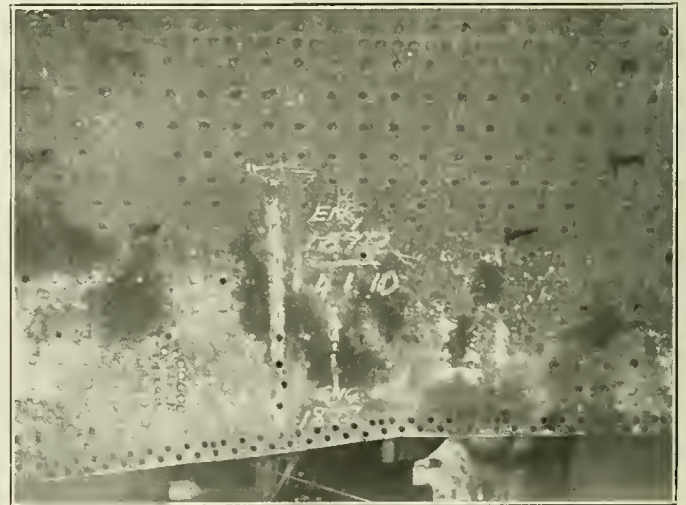

Fig. 3—Showing the Staybolt Cracks in the Side Sheets

the inside sheets and the outside sheets for various conditions of heat and pressure. A boiler exactly similar to the one that

able conditions at the West Albany shops, a wide firebox boiler being used. Six sets of tram marks were made on both the inside and outside of the boiler, as shown in Fig. 1, the

\*Abstract of a paper presented before the Western Railway Club, April 18, 1916.

sixth one being made in the crown sheet and the roof sheet. The same procedure was followed as in the previous test, and here again it was shown that the expansion of the outer sheet was greater in every case than that of the inner sheet. The following table shows the results of these tests:

Mark No.	Outside Wrapper Sheet		Inside of Firebox		Difference in Expansion
	Location	Expansion	Location	Expansion	
1—	Side Sheet.....	3 16 in.	Side Sheet.....	1 8 in.	1/16 in.
2—	Side Sheet.....	5 32 in.	Side Sheet.....	3/32 in.	1/16 in.
3—	Side Sheet.....	1 4 in.	Side Sheet.....	5/32 in.	3/32 in.

throat sheet and passing through the outer throat sheet, as indicated in Fig. 1, that the inner tube sheet moved outward 3/32 in. when the fire was first started and before the circulation was fully established, and later when steam pressure began to rise, backward about 1/16 in. The first movement of the needle throws some light on the cause of the side sheet popping out along the fire line as they sometimes do.

At the left in Fig. 4 is shown an installation of flexible staybolts which, when adjusted as shown by the table under-

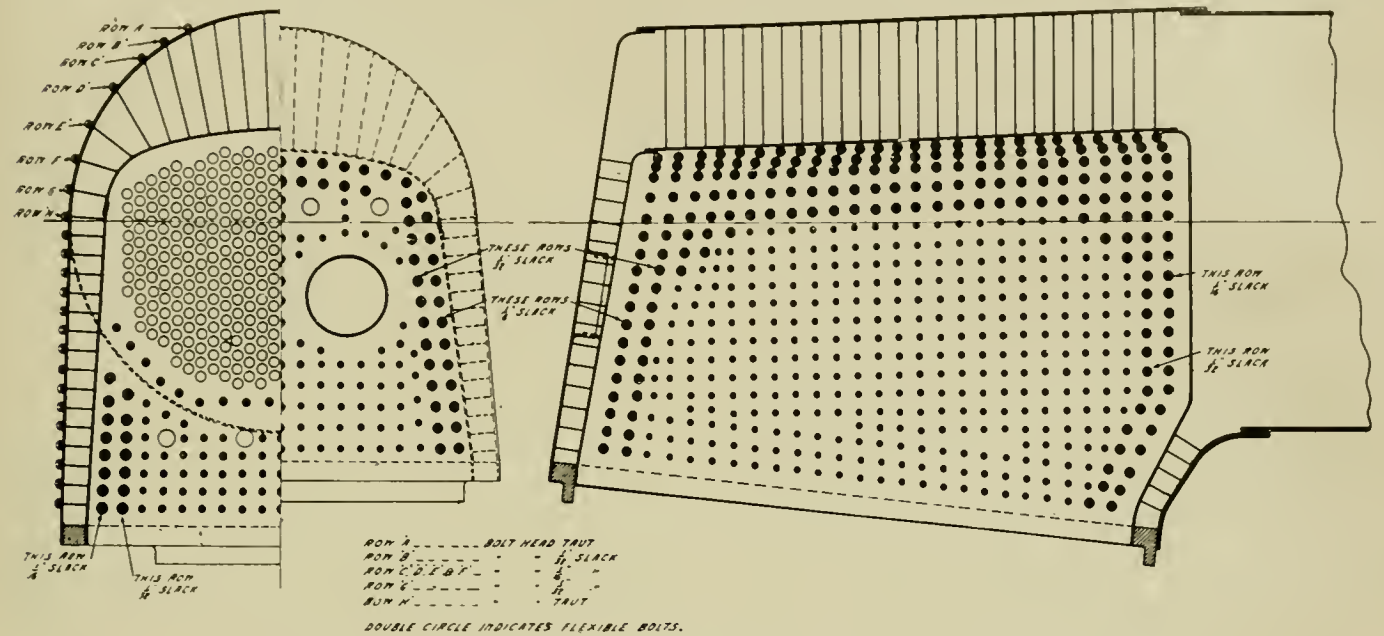

Fig. 4—Application of Flexible Staybolts to Relieve Working Stresses in Locomotive Fireboxes

4—	Side Sheet.....	3/16 in.	Side Sheet.....	1/8 in.	1/16 in.
5—	Side Sheet.....	7/32 in.	Side Sheet.....	1/8 in.	3/32 in.
6—	Wagon Top.....	7/32 in.	Crown Sheet.....	5/32 in.	1/16 in.
1—	Throat Sheet.....	5/32 in.	Tube Sheet.....	7/64 in.	3/64 in.
2—	Throat Sheet.....	3/16 in.	Tube Sheet.....	1/8 in.	1/16 in.

This would seem to account for the breakage of the back head and throat sheets along the outer row of staybolts, also

neath the illustration, will relieve the stresses that cause the vertical cracks between the outer row of staybolts in the back head of the boiler. On the right in Fig 4 is shown an installation of flexible staybolts which, with the method of adjustment indicated, will relieve the stresses which are responsible for the cracked side sheets and cracked throat sheets. Both the New York Central and the Michigan Central have followed this plan with excellent results—and in addition apply a full installation of flexible staybolts in the throat sheets,

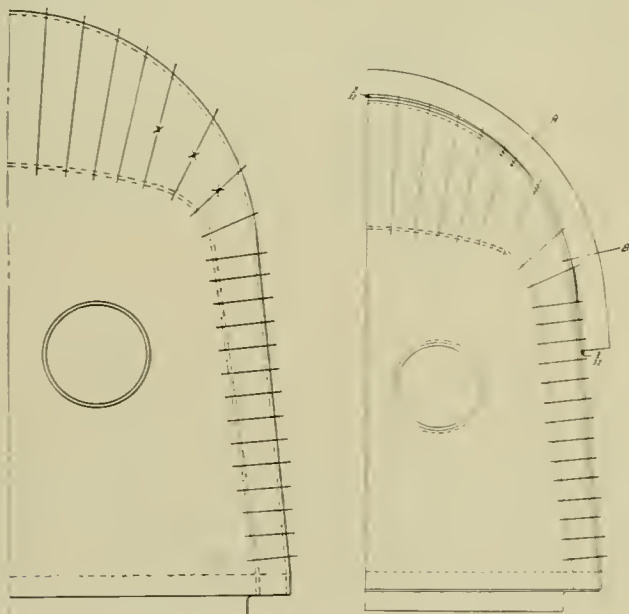

Fig. 5

Fig. 6

for the vertical cracks in the side sheets, as well as the cracks extending from the arch tube holes (see Figs. 2 and 3). It was also found by means of a needle connected to the inner

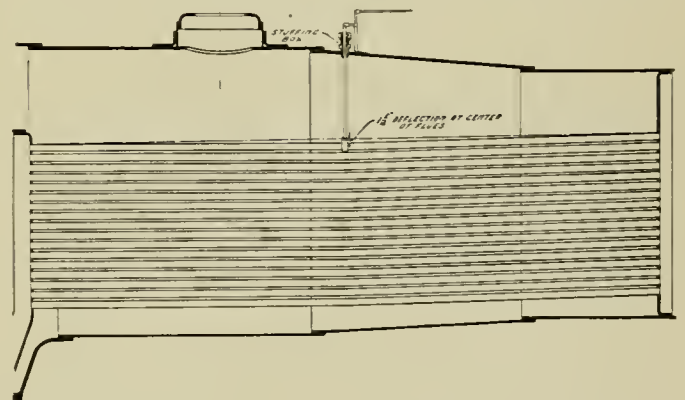

Fig. 7—Arrangement of Pointer in Boiler Tube Deflecting Test

the first row above the mud rings being set tight, the second row 1/32 in. loose, and all others 1/16 in. loose. The back tube sheet braces are set 3/32 in. loose. It is believed this practice will increase the life of a modern firebox from 50 to 75 per cent. The loose installation of these flexible staybolts is considered necessary in order to avoid excessive staybolt and tube sheet breakages. At the same time it will

reduce the strain on the arch tube anchorages and eliminate quite a source of trouble.

In February, 1907, a full installation of flexible staybolts was made on an Atlantic type engine when this engine received a new firebox. They were of the Tate flexible type, with the exception of four bolts directly under the safety valve dome, and four under the steam turret, also eight bolts which go on the top seam of the back head, which were sling stays. From the time this installation was made to October, 1915, when a superheater was applied and the side, tube and door sheets were renewed, this engine made over 500,000 miles without a flexible staybolt failure. During this time the engine was shopped for general repairs five times, the old tube sheet was patched three times and one new tube sheet applied, the mud ring corners were patched three times and the right side sheet patched once.

Another source of trouble was found with the breakage

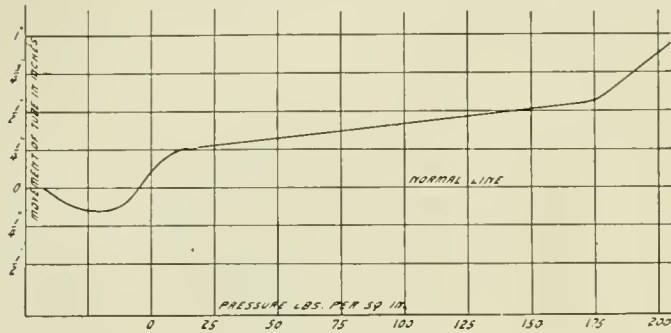

Fig. 8—Curve Showing Movement of Tube; Boiler Fired Up Without Blower

of the staybolts, indicated by X in Fig. 5, in some of the wide firebox engines. We believed that the cause of these bolts breaking was the same as that which was responsible for the leaky side sheet seams, and further, that the elimination of excessive staybolt breakage would result in a cure for these leaky seams. When these locomotives were built, rigid bolts were applied in these rows, and it was quite common to find anywhere from 3 to 5 or more bolts broken. An experiment was tried on an engine of this type which was in the West Albany shop for general repairs, by Mr. Linderman, who was at that time supervisor of boilers. A heavy

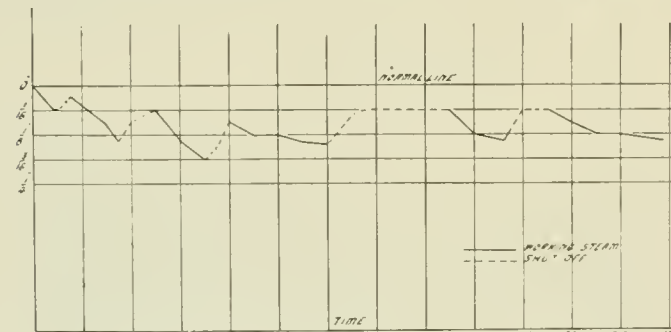

Fig. 9—Curve Showing Movement of Tube in Road Service, West Albany to Rotterdam Jct.

templet was fitted over the side of the boiler, as shown in Fig. 6, when the boiler was cold. It was firmly clamped at its center to the boiler. The fit was very carefully made, a man working nearly a week to have it absolutely accurate. The engine was then fired up and the effect of heating up the boiler to the point where 200 lb. of steam was obtained caused the wrapper sheet to bulge out so that there was 3/32 in. opening between the templet and the wrapper sheet at both ends of the templet. This, it seems, explained the cause of these staybolts breaking. In order to determine whether this

distortion of the boiler was caused by the pressure or the heat, the templet was carefully refitted and a pressure of 225 lb. of cold water put on the boiler. The templet retained its seat, which proved conclusively that the distortion was due to the temperature and not to the pressure. The application of three rows of flexible staybolts with 1/32 in., 1/16 in.

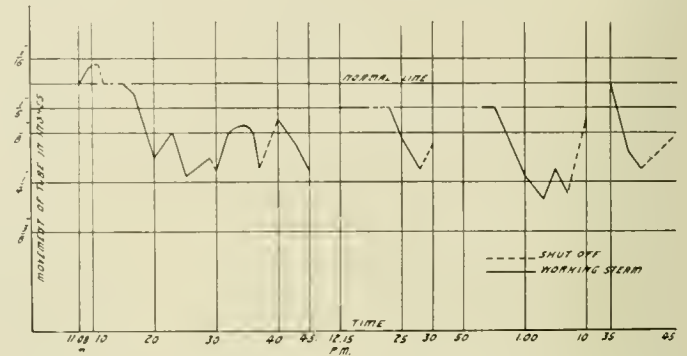

Fig. 10—Curve Showing Movement of Tube in Road Service, Utica to Palatine Bridge

and 1/32 in. slack, respectively, stopped the trouble and cured the trouble from leaky seams.

The New York Central has also made experiments to determine why the back and front tube sheets become deflected or distorted. It was believed that while the boiler was working and had a hot fire the circulation of the water being good the expansion in the boiler proper, that is between the tube sheets, was greater than in the tubes. An experimental set of tubes was installed in a large Pacific type locomotive, each tube being given a drop of 1 5/16 in. at the center before it

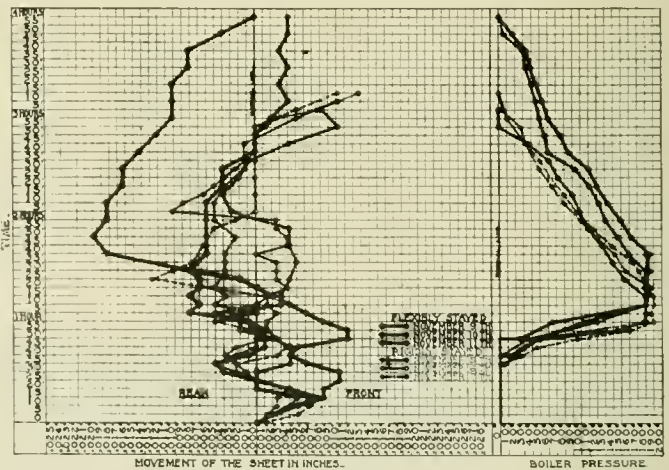

Fig. 11—Relative Movement of Back Tube Sheet to Throat Sheet

was fastened at each end. The work was under the direction of Mr. Linderman. A rod was fastened to one of the top tubes at the center and extended up through a stuffing box in the boiler shell, as shown in Fig. 7, the outer end being attached to a recording device which would register the movement of the tube. Fig. 8 gives the result of a standing test from the time the fire was started until 200 lb. pressure in the boiler was obtained. It will be noted that almost immediately after the fire was started the tube deflected still more until it had reached 1/8 in. It remained in this position for a short time and then it raised and was about 1/8 in. above the normal position when the steam pressure began to rise. It rose gradually until 175 lb. pressure was obtained, and then rose rather abruptly. This rapid rise cannot be accounted for unless it might be that the needle did not work in the stuffing box quite as freely as it should, although the packing in the stuffing box was very loose.

Following this test, road tests were made under the direction of Mr. Linderman and Mr. McPartland, the latter an engineer of long experience in testing locomotives and their appliances. Fig. 9 is the record made by the recording device on the first road trip, which was from West Albany to

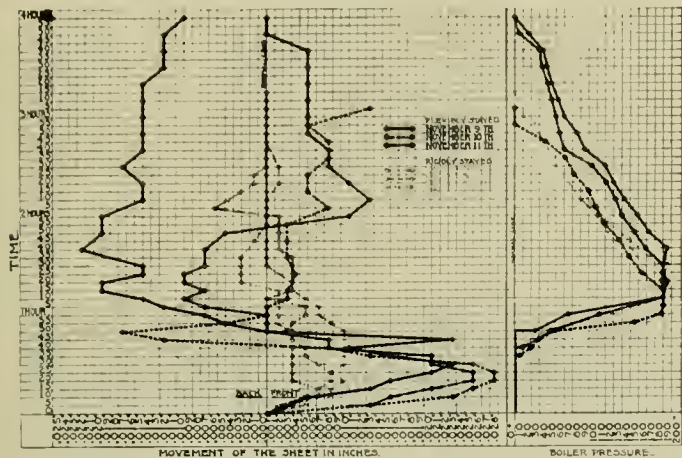

Fig. 12—Relative Movement of Back Firebox Sheet to Back Boiler Head

Rotterdam Junction. The solid lines in this diagram are readings taken when the throttle was open, and the dotted lines when the throttle was closed and while the engine was drifting. It will be noted that immediately upon starting the tubes began to deflect, and that they would rise when the engine was not working steam. The maximum deflection was 3/16 in., this point having been reached while the engine was being worked hard and running at a good speed.

Fig. 10 is the record in the second road test, which was made from Utica to Palatine Bridge. The rise of 1/16 in. above the normal line at the start of the trip cannot be ex-

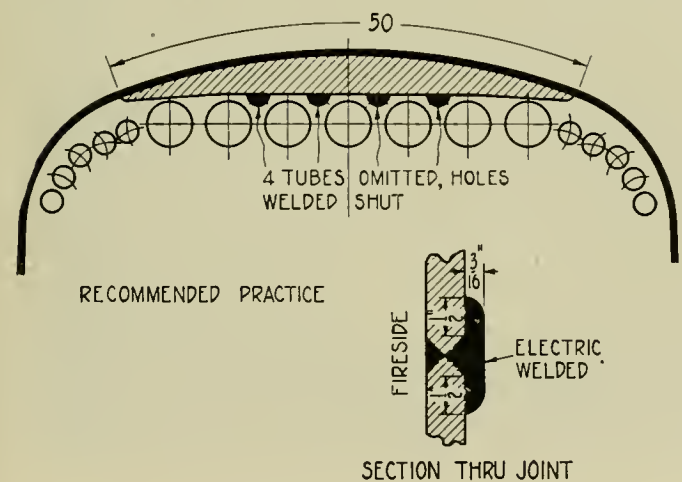

Fig. 13—Method of Patching Tube Sheet

plained, but it will be noted that it did not occur again on the trip. The balance of the record is very nearly a repetition of what occurred on the first trip, the increase in the deflection in the tube being, in our opinion, due to the fact that the engineer on this trip worked the engine harder than did the engineer on the first trip. The maximum deflection was 5/16 in. The break in this diagram indicates periods during which the apparatus was cut out while switching was being done. The line at the right of the card, which shows the tube back in its normal position, followed quite a long stop at a station.

We have also had some trouble with the staybolts in the throat sheets. On certain of the large locomotives which were purchased with a full installation of rigid staybolts a great

number of these bolts were found broken or fractured about four or five months after the engine had been placed in service. The cure that was applied in this case was the complete installation of flexible staybolts over the whole throat sheet. It was also found that the braces between the tube sheets and the boiler shell at the throat sheet would become broken. This has been overcome by putting on the belly braces with a 1/16-in. slack under the nut at the crowfoot on the belly of the boiler. This is usually done by first pulling up one nut tight, backing it off 1/16 in. and then setting the jamb nut. These braces seldom, if ever, break, nor do they pull the rivets off the fire side of the tube sheet. It is the standard practice on the New York Central at the present time.

An investigation was also made to determine the direction and extent of expansion in a tube sheet resulting from prossering a set of new tubes. A circle of as large diameter as possible was described on the tube sheet before the tubes were set. After the tubes had been set it was found that this circle had increased, or had widened out 1/32 in. at the sides and bottom, and 3/32 in. at the top. When it is considered that we were at that time prossering the tubes at least once every 30 days, it will be readily understood why the flange at the front end of the crown sheet is deformed. It has been our experience that the 3-in. radius for the tube sheet flange will give better results than the 2-in. radius.

Fig. 11 is a diagram indicating the relative movements of the back tube sheet to the throat sheet from the time the boiler is heated up and raised to 200-lb. pressure and released back to zero pressure. Two engines of exactly the same type were tested, one having all flexible staybolts, and the other all rigid staybolts. The light lines indicate the sheet movement on the rigidly stayed boiler, and the heavy lines that of the flexible stayed boiler. Three sets of tests were made with each boiler. This shows pretty plainly that there is a necessity for some freedom of the sheets longitudinally in order to avoid excessive strains being set up.

Fig. 12 shows the relative movement of the back fire box sheet and the back boiler head. Fig. 13 shows the process recommended for patching the top of a tube sheet that had been cracked from the top of the tube holes up to the flange. The patch is welded in and reinforced by a rib on the water side as shown in the cross section, and it is believed that it is as strong as the original sheet was before the beginning of the cracks. For a horizontal crack around the flange of the tube sheet a first-class job can be made without patching by simply welding, as shown in the cross section.

### PULVERIZED FUEL FOR STATIONARY BOILERS ON THE MISSOURI, KANSAS & TEXAS

During the winter of 1912, when the natural gas supply was limited in quantity and fuel oil hard to obtain in Kansas, the officers of the Missouri, Kansas & Texas decided to investigate other methods for generating steam in the boilers at the powerhouse of the shops at Parsons, Kan. There were at this point, eight 250-hp. boilers of the Heine water tube type, equipped for using natural gas and oil as fuel. Some of the other fuels available in the district, which would be within an economical range as to cost delivered at the plant, were soft coals from the Mineral mine in Kansas, the McAlester and Lehigh mines in Oklahoma, and lignite from Texas, with the following analyses:

Kind of coal	Fixed carbon	Volatile	Ash	Moisture	B. t. u.
Mineral	45.22	26.39	20.38	8.01	10,640
McAlester	47.07	32.37	14.29	6.27	11,837
Lehigh	41.40	31.28	19.29	8.03	11,200
Lignite	25.50	33.95	7.58	32.97	7,548

The sulphur, separately determined, ranged from approximately 3 to 5 per cent in the various soft coals.

Owing to the ash and moisture content of these fuels, it was determined to investigate methods of using them in pul-

verized form, as it was known that pulverized bituminous coal has been in successful use in the cement industry, in a major portion of the plants throughout the country. This investigation resulted in the placing of a contract for the necessary equipment at the Parsons power house with the Fuller Engineering Company, Allentown, Pa., and the material and machinery were delivered in the fall of 1913. Owing to financial conditions, it was thought unwise to make the change at that time, but in the early part of 1916, owing to the abnormal price of fuel oil, orders were given to proceed with the work. The equipment was installed and the plant was placed in successful operation on August 1, 1916.

The equipment for pulverizing and drying fuel is contained in a separate building, which is located near one end of the boiler house and the coal is dumped from the cars

through a  $\frac{3}{4}$ -in. mesh or less and delivers it into a dust-tight elevator, from which it is distributed by a 12-in. screw conveyor into a storage bin of 50 tons capacity over the coal dryer.

The equipment throughout the pulverizer plant is operated by Westinghouse three-phase, 60-cycle motors at 440 volts. The first crusher is driven by a 10-hp. belt connected motor, while the inclined belt conveyor and the second crusher are operated by one 15-hp. belt connected motor, this arrangement obviating any possibility of choking the crusher. The elevator and screw conveyor by means of which the coal is taken from the rolls and delivered to the storage bin are operated by one 10-hp. back-gearied induction motor.

Coal may be drawn from any part of the storage bin and delivered by means of a screw conveyor to the Fuller Engi-

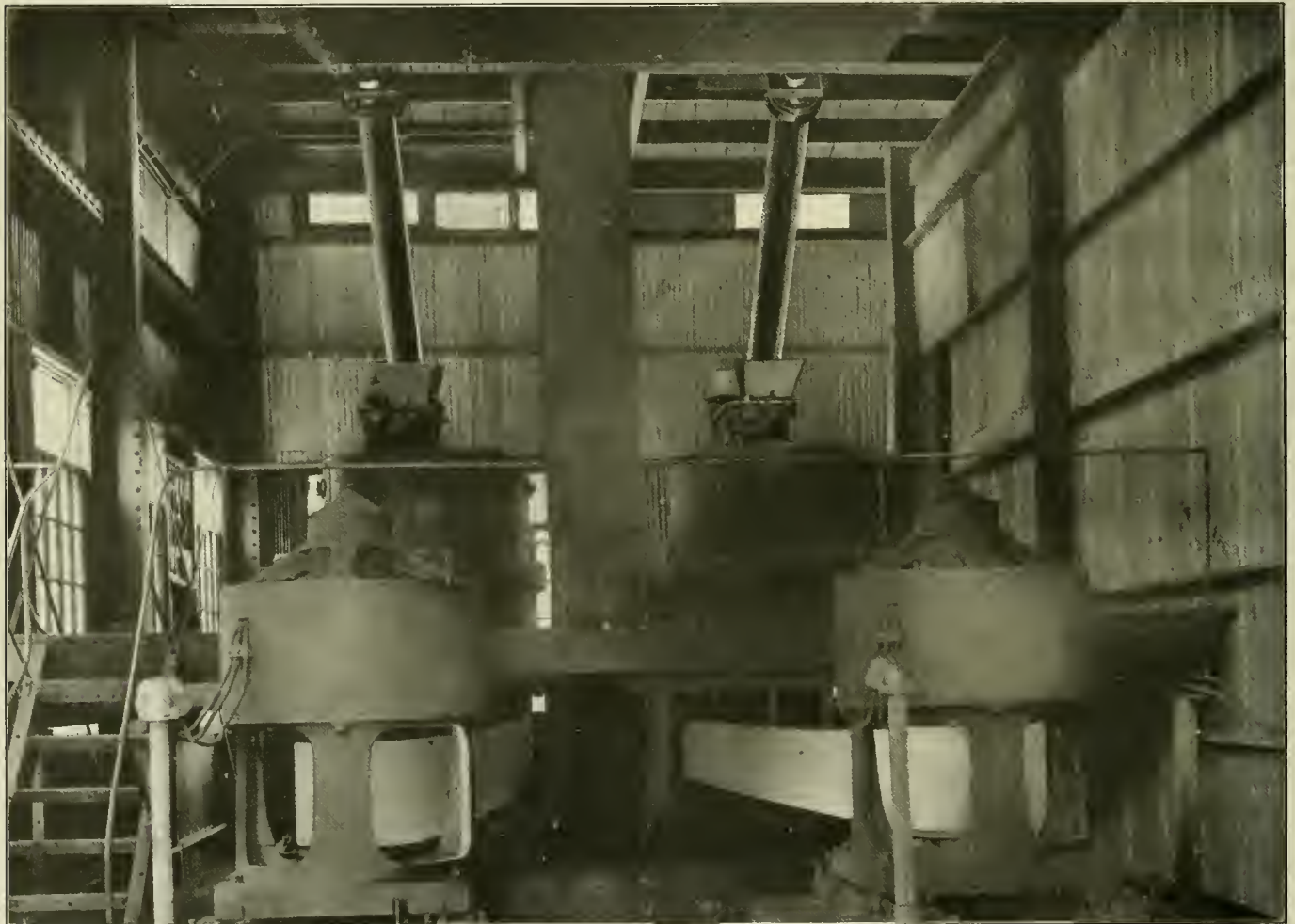

Fuller-Lehigh 42-in. Pulverizer Mills at the Parsons Plant

directly into a concrete track hopper of 50 tons capacity adjoining this building. The plant is designed to handle either mine run or slack coal and immediately below the track hopper is placed a set of 24-in. by 20-in. Jeffrey double spike-tooth rolls, which will reduce lumps up to 12 in. by 18 in. to 5-in. cubes or less in one operation. As the coal passes through this crusher, it drops onto a 20-in. inclined belt conveyor, which discharges directly into a set of Lehigh 24-in. by 18-in. corrugated rolls. The upper end of the belt conveyor passes over a 24-in. by 22-in. Cutler-Hammer magnetic separator pulley, the function of which is to remove any pieces of iron or steel which may be in the coal and retain them on the belt until the latter passes off the underside of the pulley, the metal then dropping to the floor behind the crusher. This crusher reduces the coal to pass

neering Company's indirect fired dryer, a chute from the conveyor being provided for the delivery of coal to the floor for firing the dryer furnace. The dryer is driven by a 10-hp. induction motor and will evaporate the moisture from coal containing 10 per cent moisture, to  $\frac{1}{2}$  per cent at the rate of eight tons per hour. In order that lignite, containing from 30 to 50 per cent moisture may be handled, the dryer is arranged so that the material may be passed through as many times as may be necessary to reduce the moisture to the desired maximum before the coal is delivered to the pulverizer.

From the dryer the coal is discharged directly into a second dust-tight elevator, delivering to a 12-in. screw conveyor, both of which are driven by a 10-hp. back-gearied induction motor. The conveyor discharges the fuel

into two bins of 40 tons capacity each, which feed two four-inch Fuller-Lehigh pulverizing mills. The material to be reduced is fed to the mill by means of a feeder mounted on top of the mill. This feeder is driven direct from the mill shaft by means of a belt running on a pair of three-step cones, which permits the operator to accommodate the amount of material entering the mill to the nature of the material being pulverized. In addition, the hopper of the feeder is provided with a slide, which permits the operator to increase or decrease the amount of material entering the feeder hopper.

The pulverizing element of the mill consists of four unattached steel balls which roll in a stationary, horizontal concave grinding ring. The balls are propelled around the grinding ring by means of four pushers attached to four equidistant horizontal arms forming a portion of the yoke, which is keyed direct to the mill shaft. The material dis-

through the screen surrounding the separating chamber, thus insuring cooler operation and maximum screening efficiency. This current of air keeps the screen clean and enables the mill to handle material containing a considerable amount of moisture without affecting the efficiency of the machine. As soon as the material is reduced to the desired fineness, it is lifted out of the pulverizing zone and discharged. Each pulverized is belt driven by a 60-hp. vertical motor and reduces the fuel so that 95 per cent of it will pass through a 100 mesh screen and 85 per cent through a 200 mesh screen, at the rate of four tons per hour, the plant having a maximum capacity of eight tons per hour.

The grouping of the drives for the various parts of the equipment makes possible a maximum utilization of the power consumed, as only such parts of the plant as are in actual use need be running at any time. When fully loaded the actual power consumed is within about five per cent of

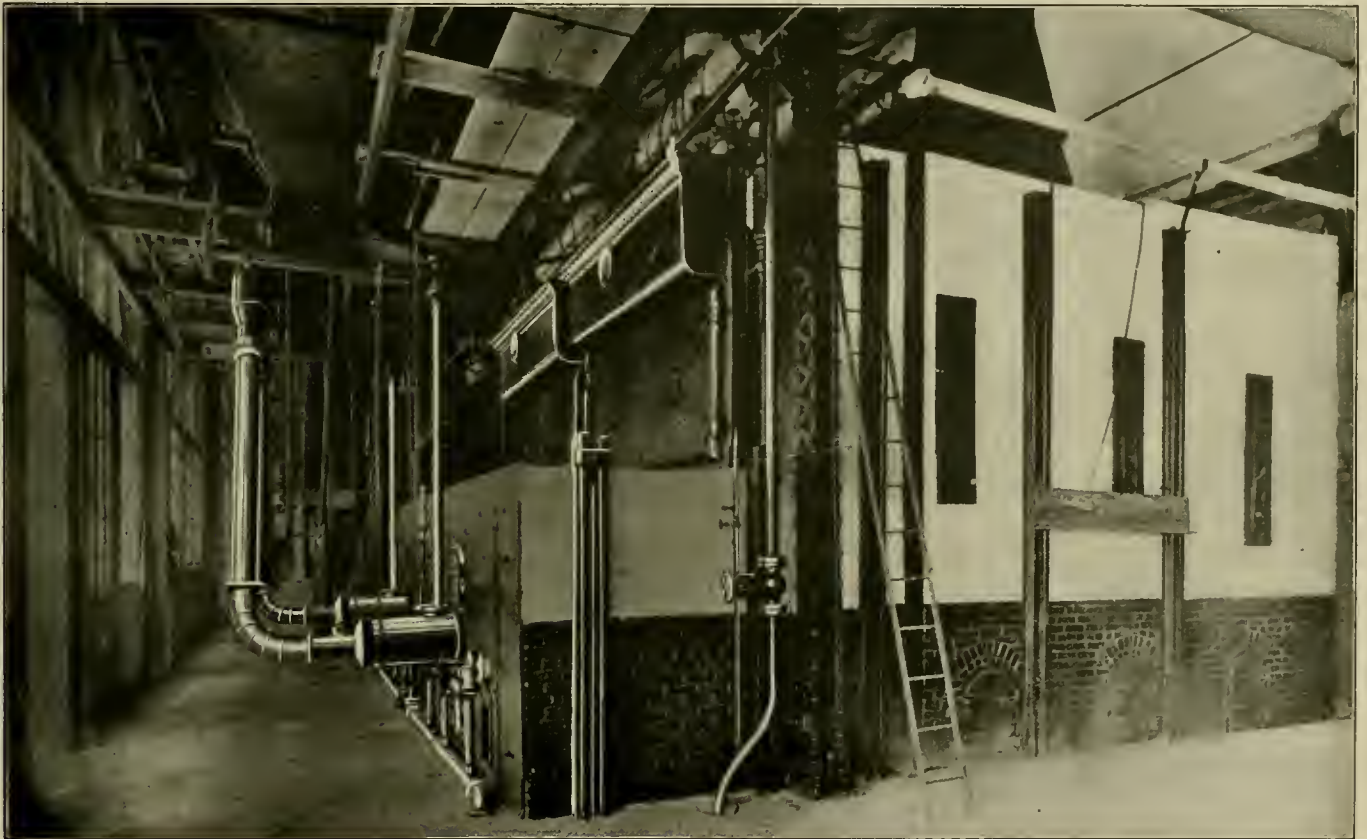

Heine Type, Horizontal Tubular Boilers Burning Pulverized Fuel, at the Parsons, Kan., Shops of the Missouri, Kansas & Texas

charged by the feeder falls between the balls and the grinding ring in a uniform, continuous stream, and is reduced to the desired fineness in one operation. Fan discharge mills are fitted with two fans; one of these fans operates in the separating chamber immediately above the pulverizing zone, whereas the other fan operates in the fan housing immediately below the pulverizing zone. The upper fan lifts the fine particles of pulverized material from the grinding zone into the chamber above the grinding zone, where they are held in suspension. The lower fan acts as an exhauster and draws the finely divided particles through the finishing screen which completely encircles the separating chamber. The material leaving the separating chamber is drawn into the lower fan housing, from which it is discharged by means of the action of the lower fan. All the material discharged is the finished product which requires no subsequent screening.

The current of air induced by the action of the lower or discharge fan passes over the pulverizing zone and out

the rating of the motors, according to observations taken since the plant has been in service.

As the fuel leaves the pulverizer, it is discharged into a third dust-tight elevator and delivered to a 12-in. screw conveyor for transfer to the bins in front of the boilers. This elevator and screw are driven by a 15-hp. induction motor, the conveyor passing from the pulverizer building to the power house through a steel bridge covered with corrugated sides and roof. This is the only connection between the pulverizing plant and the power house.

The capacity of the pulverized plant is 180 tons in 24 hours and the requirements of the power house are at present about 96 tons in 24 hours. Arrangements are being made for the trial of pulverized coal in locomotive service, one engine now being in process of equipment, and an outside storage bin will be added to the plant to supply fuel directly to the locomotive.

The boilers are arranged in batteries of two each and, as equipped for burning gas and oil, the combustion takes

place in the furnace directly under the heating surface of the boiler. For pulverized fuel, however, a Dutch oven furnace has been built on the front of the boiler setting, it having been found that the best results are obtained in this manner. The equipment for burning the fuel is simple. Each pair of boilers is provided with a blower, driven by a 10-hp. constant speed direct current motor, the blast pipes from this blower entering the rear end of an induction tube which extends through the wall of each furnace. Each blast pipe is fitted with a gate for controlling the air jet to the combustion tube. The fuel from the bin passes through a four-inch screw feeder, which accurately determines the rate at which the coal is delivered to the furnace, each feeder being driven by a 2-hp. variable speed motor. The fuel from the feeders is led by gravity through a pipe entering the top of the induction tube near the front of the furnace. The action of the high velocity jet from the blast pipe induces a large volume of air at lower velocity through the induction tube; the fuel is caught by this current, with which it is thoroughly mixed, and enters the furnace at a low velocity, burning with a lazy flame which practically fills the combustion chamber.

The fuel bins in front of the boilers have a capacity equivalent to 16 hours' service at boiler rating. The bins and supports are of steel and the bins are closed with steel covers which are dust-tight. Each bin is hopped and is equipped with a hand operated agitator, the purpose of which is to prevent the bridging over of fuel in the hopper.

Considerable experimental work has been done in order to secure the best furnace arrangement and to provide an effective control of combustion to meet the requirements of varying loads on the boilers. As installed for the use of gas, the boilers were provided with three-pass horizontal baffles. In the pulverized fuel fired boilers these baffles are being replaced by a vertical three-pass arrangement from which excellent results have been obtained, as the following list of temperatures indicates. These temperatures were taken starting at the bottom of the first pass and proceeding in the direction of the flow of the gases over the heating surfaces of the boiler.

Location—	Temperature, deg. F.
Bottom of first pass.....	1,650
Top of first pass.....	1,260
Top of second pass.....	1,180
Bottom of second pass.....	960
Bottom of third pass.....	800
Top of third pass.....	705
Stack temperature (average).....	508

These temperatures were taken under operating conditions with a draught averaging .26 inch of water.

Various tests have been made with the different fuels mentioned and all of them were burned with entire success, giving an effective distribution of the heat throughout the heating surface of the boiler with low stack temperatures. No deposit of ash settled anywhere in the boiler but what was readily dislodged with an ordinary air blast.

With Texas lignite and an output of 110 per cent rating, an equivalent evaporation of 7.26 lb. of water was obtained per lb. of coal fired, an equivalent evaporation of 8.81 lb. being obtained per lb. of combustible. The coal as fired had a heating value of 11,250 B. t. u. and contained 7 per cent moisture, the dryer not being designed to handle this class of fuel regularly. The efficiency of the boiler was 67.3 per cent, the losses being as follows: .7 per cent due to evaporation of moisture in the coal; 4.8 per cent due to steam from hydrogen combustion; 11.8 per cent carried away by dry flue gasses, and 15.4 per cent due to radiation and unaccounted for.

With the boiler operating at about 92 per cent of rated capacity an equivalent evaporation of 8.38 lb. of water per lb. of coal fired was obtained with Mineral slack (Cherokee Co.,

Kansas), the fuel as fired containing one per cent of mois-

ture and having a heating value of 11,580 B. t. u. The equivalent evaporation per lb. of combustible was 10.9 lb. In this case the boiler showed an efficiency of 71.5 per cent, the losses being: .3 per cent due to evaporation of moisture in the coal, 3.8 per cent due to steam from hydrogen combustion; 10.8 per cent in dry flue gasses, and 13.6 per cent radiation and unaccounted for. In neither case was there any CO loss.

Including the cost of pulverizing, which is about 35 cents per ton, the cost of Mineral coal delivered to the bins was \$1.795. The fuel of evaporating 1,000 lb. of water as determined by this test was 11.6 cents. Using natural gas, the heating value of which is about 940 B. t. u. per cu. ft., the cost of evaporating 1,000 lb. of water is 16 cents, with gas at 12.5 cents per 1,000 cu. ft.

The normal coal feed is arranged to develop about the rated capacity of the boiler. At maximum feed, however, the boilers may be forced to 142 per cent of rated capacity. No difficulty has been experienced from abnormal furnace temperatures, which would tend to destroy the furnace walls. Even under forced conditions the furnace temperature does not exceed 2,350 deg. F., and under normal conditions it is about 2,100 deg. F.

## FOUR-CYLINDER ATLANTIC TYPE LOCOMOTIVE, GREAT NORTHERN OF ENGLAND

The locomotive illustrated was converted under the direction of H. N. Gresley, locomotive engineer of the Great Northern Railway of England, from a two-cylinder to a four-cylinder simple, the boiler being equipped with the Robinson superheater. The engine differs from other 4-4-2 type locomotives inasmuch as all four cylinders drive the rear coupled wheels. The arrangement of the cylinders and driving gear is shown in one of the drawings.

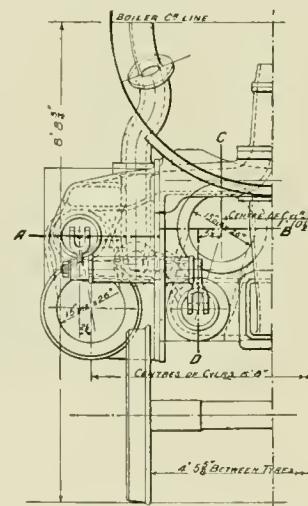

Cross Section Showing the Cylinder Arrangement.

The outside connecting rods have a length of 10 ft. and the inside ones 7 ft. 7 in., the inside cylinders being located to the rear of the outside ones. Walschaert valve gear is applied directly to the piston valves of the outside cylinders, which valves work above the cylinders. Motion is conveyed to the piston valves of the inside cylinders by means of rocking levers and a transverse shaft with connecting mechanism, the motion being transmitted from the higher level of the outside valve spindles to the lower one of the inside valves, as is shown in the drawing, the valves of the inside and outside cylinders working in opposite directions. The crank axle is constructed on Ivatt's patent built-up balanced principle.

As originally constructed, the engine had two outside cylin-



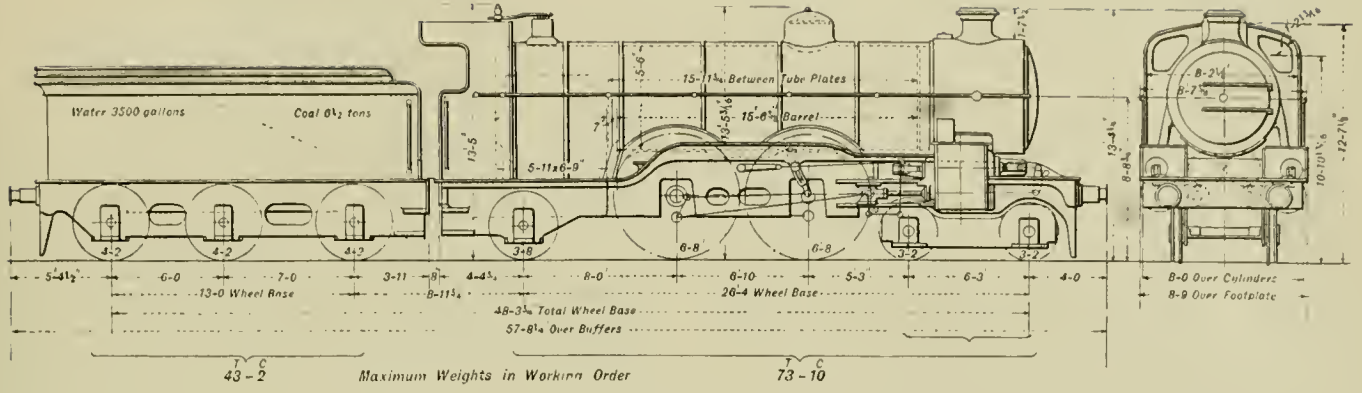
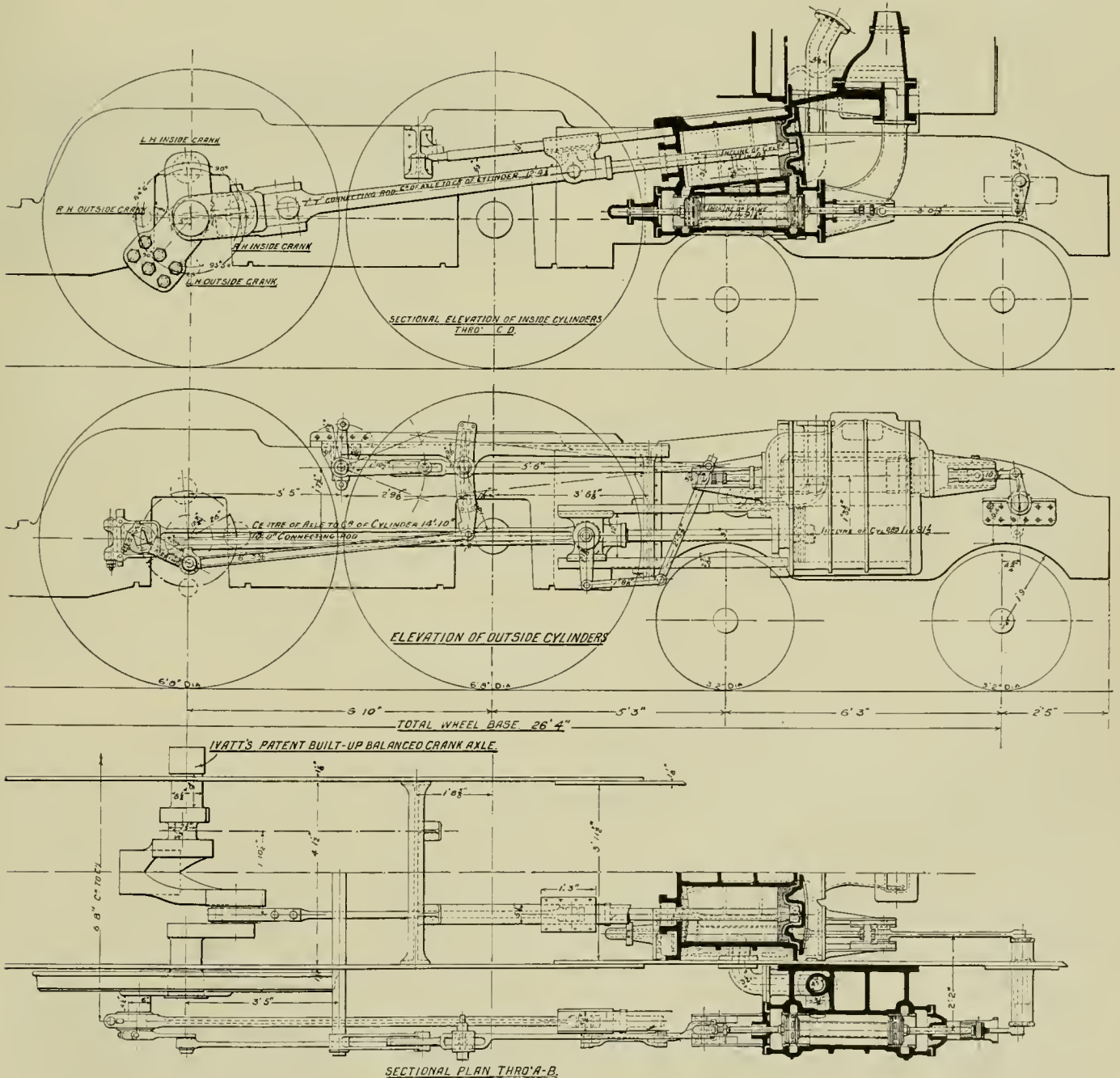

Diagram Showing the Principal Dimensions and Weights of the Great Northern Locomotive; The Weights Are Given in Tons of 2,240 lb., and Hundredweights.



Arrangement of the Cylinders and Rods of the Great Northern Atlantic Type Locomotive

ders, 18 3/4 in. by 24 in. The following are the leading particulars of the engine as now running:

Cylinders (four), diameter and stroke.....	15 in. x 26 in.	
Driving wheels, diameter.....	6 ft. 8 in.	
HEATING SURFACE		
144 tubes 2 1/4 in. outside diameter = 1,355 1/2 sq. ft. }		1,882 sq. ft.
24 tubes 5 1/4 in. outside diameter = 526 1/2 sq. ft. }		
Firebox .....	138 sq. ft.	
Total .....	2,020 sq. ft.	
Superheater surface .....	427 sq. ft.	
Grate area .....	31 sq. ft.	
Working pressure per sq. in.....	170 lb.	
Weight in working order.....	164,500 lb.	
Weight of engine and tender in working order.....	261,000 lb.	

## CLIPBOARD FOR ANALYZING INDICATOR CARDS

BY H. K. FOX

Motive Power Inspector, Western Maryland, Hagerstown, Md.

Within the past eight months we have taken about 1,400 indicator cards and the task of integrating them is no small one. The method heretofore followed was to pin a card on a drawing board with two thumb tacks, the surface for the planimeter wheel to roll over usually being a piece of smooth paper. For the integration of the diagram areas of a card this method gives a fair degree of satisfaction, but the real difficulty came when drawing parallel vertical lines at fractional parts of the stroke. When doing this with a pair of triangles several adjustments were frequently necessary to finish one card and a further annoyance was found in the tack heads, over which one of the triangles frequently had to be placed.

To overcome these obstacles to a quick solution, a clip-

## CHART FOR DETERMINING THE EXPANSION OF METALS

BY W. F. SCHAPHORST

The accompanying chart was devised to facilitate the calculation of expansion in various kinds of metals, ranging from mild steel to bronze. It covers any length of steam pipe or bridge, etc., from 20 ft. to 10,000 ft. On the scale of coefficients are indicated the values of the various materials so that the chart may be used direct without the necessity of first looking up this information.

The broken lines on the diagram indicate the method of using it and refer to the following example: How much will 850 ft. of wrought iron steam pipe expand where the



Clipboard Used in Analyzing Indicator Cards

board was designed as shown in the illustration. On this board the cards are very quickly applied or removed, and this can be done as many times as desired without the least injury to the card. The clip firmly holds the card in position and a small straight edge is glued on the board to serve as a guide for the triangle. The board itself is about 3/8 in. thick, 9 in. wide, and 13 in. long. The straight edge is 0.06 in. thick and 0.25 in. wide, and is set about 3 1/2 in. from the edge of the board, the set screws on the under side of the planimeter clearing it nicely. The clip is 3 in. wide, being made from an ordinary 6 in. clip by cutting off the proper amount from each wing. The board is of hardwood and the surface over which the roller wheel runs has been specially prepared to provide an extremely smooth, glass-like finish.

As to the saving in time required for working up cards, about five cards are now being analyzed in the same time formerly required for three.

**HARDENING IN ELECTRIC FURNACES.**—The latest electric furnaces cost about the same to operate as gas furnaces when the current is 3 1/2 cents per kilowatt and the gas is 80 cents per thousand cubic feet, the gas having about 600 B. t. u. per cubic foot. One concern having electric furnaces using current at 1 3/4 cents per kilowatt gets its work hardened at a cost of about one-fourth cent a pound. But even if the cost were higher than with gas there is the great advantage of perfect control. An autographic record of the rise in temperature clearly indicates the critical point in the curve, and when the temperature has risen a few degrees above as shown by the recorder the charge is removed. Thus the hardener has an infallible guide, provided the pyrometers are checked daily and each heat is recorded. Inspection is checked against these records and each lot of steel is tested before fixing the temperature for quenching. By such exact methods is uniformity in hardness insured.—*Machinery.*

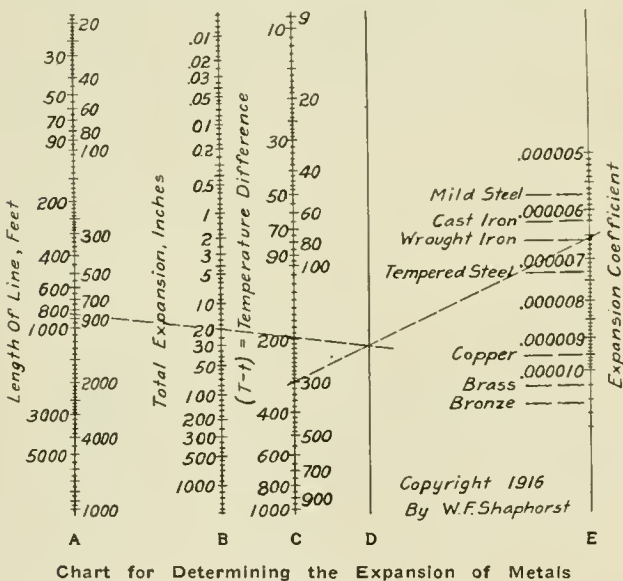

Chart for Determining the Expansion of Metals

temperature variation is 300 deg. F.? In solving the problem first connect the 300 mark on the scale of temperature difference (column C) with the coefficient of expansion of wrought iron on column E. With the point where the line thus drawn intersects column B, connect the point on column A which indicates the length of line, in this case 850 ft. The total expansion of the line in inches may be read directly from scale B at the intersection of this line.

It should be noted that column B shows the maximum variation of temperature, and not the maximum temperature, to which the material may be subjected. If the temperature of the steam pipe in the above example will never be below 40 deg. F. when cold and the maximum temperature is 340 deg., the difference of 300 deg. is the amount to be used in finding the expansion.

**APPLYING RUBBER GASKETS.**—In placing rubber packing for joints it should be coated with either graphite or chalk to prevent adhering to the metal when the joint is to be broken.—*Power.*

# LOCOMOTIVE BOILER EFFICIENCY

Heating Surfaces Not Forced to Capacity; Grates and Combustion Chambers Are Forced Beyond It

BY J. T. ANTHONY\*

## II

### HEAT REJECTED BY THE BOILER

THE heat rejected by the boiler heating surfaces amounts to a relatively small part of the total heat contained in the coal, varying from about 3 per cent to  $7\frac{1}{2}$  per cent for the boilers under consideration, as the rate of firing increases from 30 to 180 lb. While this loss is small, it is not entirely unavoidable, and can be reduced by slightly changing the arrangement of the heating surfaces.

The firebox heating surfaces receive heat by radiation from the fuel bed, luminous flames and incandescent brick work contained in the furnace. The amount of heat received by radiation depends primarily upon the extent of these radiating surfaces and upon their temperature. The transfer of heat to the firebox heating surfaces by convection takes place to a very limited extent.

The area of the firebox heating surfaces is of secondary importance to the grate area and firebox volume. The heat-absorbing capacity of water is so high and the conductivity

fire side of the sheets would be about 140 deg., or, the temperature of the fire side would be 528 deg.

Increasing the firebox heating surface adds slightly to its efficiency. By increasing the area of the surfaces receiving a fixed amount of radiant heat, we reduce the amount of heat to be absorbed by each square foot of heating surface, and therefore reduce the temperature difference between the fire and water sides of the sheets.

The amount of heat radiated depends primarily upon the area and temperature of the radiating surfaces, but is influenced to some extent by the temperature of the heating surfaces. A reduction in the temperature of the heating surfaces will increase the total amount of radiant heat absorbed and will increase the firebox evaporation, but not in proportion to the increase in heating surface.

The addition of a combustion chamber will increase the firebox evaporation to a small extent, by increasing the heating surface as explained if there is no increase in area or

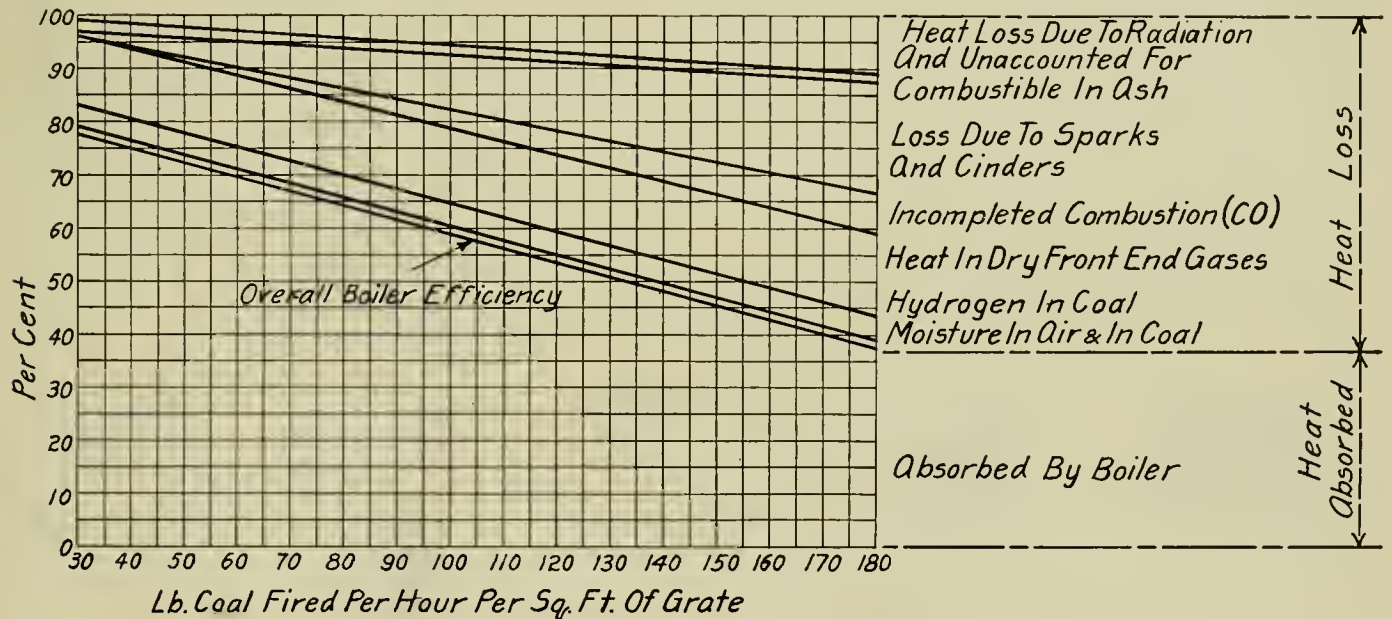

Fig. 1.—Heat Loss and Boiler Efficiency as Affected by Rate of Combustion

of the firebox sheets is so great that it is impossible to get firebox temperatures high enough to force the firebox heating surfaces to full capacity, even with present firebox design.

Under maximum conditions of power output, it is possible that an equivalent evaporation of more than 60 lb. of water per square foot of firebox heating surface per hour is obtainable; but in order to get this evaporation it is necessary to have a drop of approximately 84 deg. in temperature between the fire side and the water side of the firebox sheets. With a steam temperature of 388 deg. this means (presupposing clean sheets) that the temperature of the plate on the fire side would be 472 deg. F.

If it were possible to obtain an equivalent evaporation of 100 lb. of water per square foot of firebox heating surface per hour, the temperature drop between the water side and the

temperature of the radiating surfaces. However, the chief advantage of a combustion chamber lies in the fact that by promoting the burning of the volatile matter and coal-dust, it increases the mass of luminous flame which radiates heat; and, by increasing the extent of radiating surfaces, increases the firebox evaporation.

All of the heat generated in the firebox is either radiated to and absorbed by the firebox heating surfaces, or is carried out of the firebox by the gaseous products of combustion. It is obvious that any increase of heat absorption by the firebox will result in a lowering of temperature of the gases leaving the firebox and consequently will result in a decrease in the amount of heat to be absorbed by the tubes.

The efficiency of the tube heating surfaces increases slightly as the rate of heat transfer and evaporation decreases. Lowering the temperature of the gases entering the tubes by increasing the heat absorption of the firebox will,

\* Assistant to president, American Arch Company, 30 Church street, New York.

therefore, reduce the amount of heat to be taken up by the tubes and result in an increase in tube efficiency. It follows that under these conditions front end temperatures would be reduced and the boiler efficiency increased.

The small portion of tube heating surfaces adjacent to the firebox, which can be "seen" by the radiating surfaces, absorb some heat by radiation; but most of the heat taken up by the tube heating surfaces is by convection. That is, the heat is transferred from the hot gases to the boiler heating surfaces by the gases coming in actual contact with these surfaces and giving up their heat, which is transferred through the metal into the water by conduction. Convection implies intimate contact of the hot gases with the heating surfaces; and, in order to transfer the greatest possible amount of heat by convection, it is necessary to bring every particle of gas into actual contact with the surface of the tubes. Transparent gases do not radiate heat; neither does heat pass from one part of the gas to another by conduction. It travels only by convection—by the

tists and engineers have not been able to agree on the exact effect of these several factors on heat transmission. It is necessary to discuss them briefly here.

Since the convection of heat can take place only when the particles or molecules of gas have actual contact with the tube heating surfaces, it is apparent that the amount of heat transferred will be influenced by the number of contacts, or blows of the molecules against the heating surfaces. Increasing the density of the gas increases the number of molecules per unit of volume, and increases the number of blows or contacts of the gas against the metal. Increasing the temperature of the gases decreases the density or weight per unit of volume; therefore the benefits to be derived from an increase in temperature are partly neutralized by the decrease in density of the gases.

The velocity factor is one of great importance. The molecules of gas, on striking against the soot-covered heating surfaces, give up their heat, lose their vibratory energy, and, perhaps becoming entangled in the layer of soot, begin to

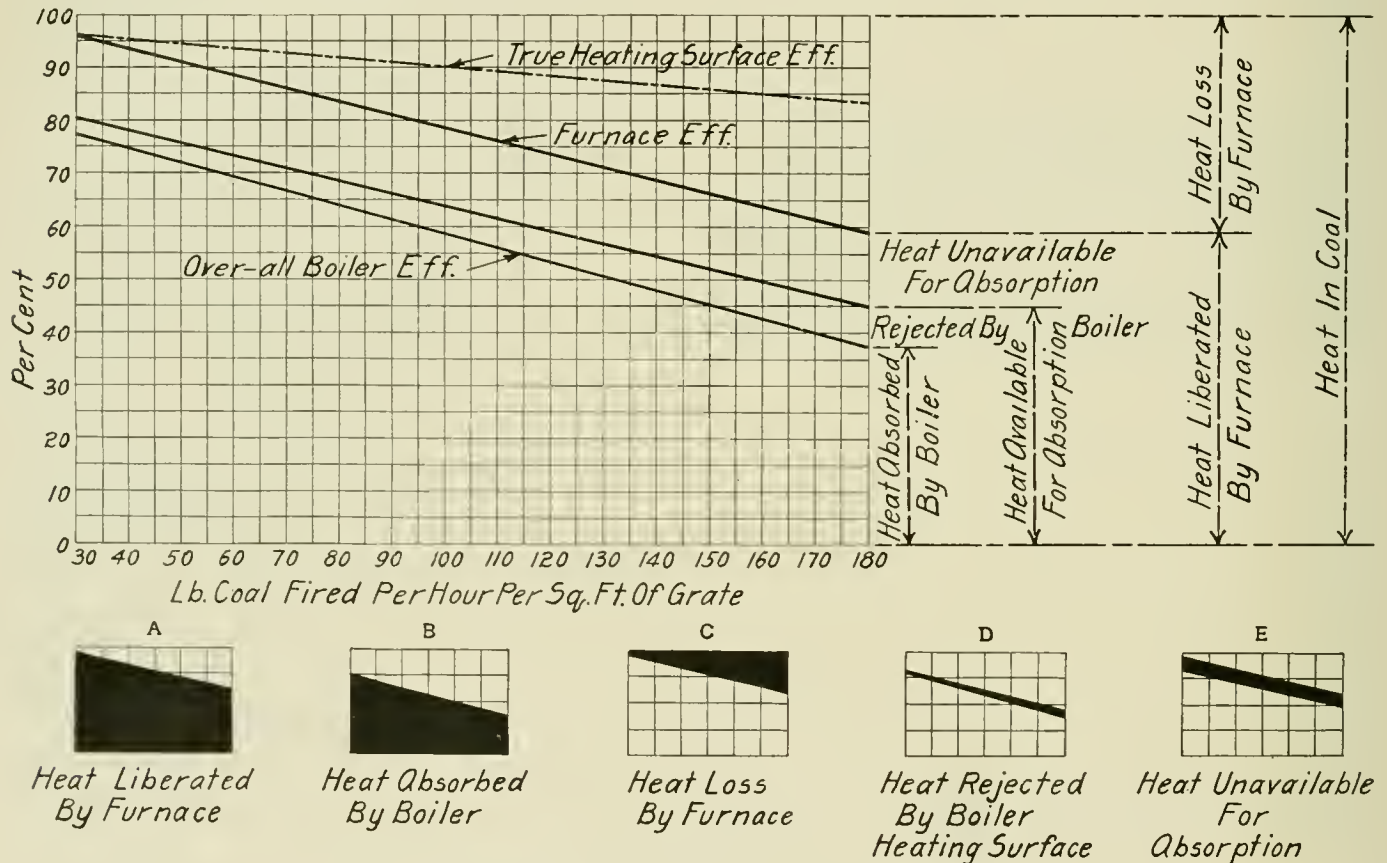

Fig. 2—Diagram Showing Heat Distribution In a Locomotive Boiler

actual movement of the particles of gas from one part of the gas stream to another.

It has been stated that the firebox heating surfaces receive practically no heat by convection. It is now apparent why. The volume of gases passing out of the firebox is so great, and the cross sectional area of the firebox is so large compared with the circumscribing firebox heating surface, that it is evident that only a very small proportion of the gases could come into actual contact with the heating surfaces on their way from the fuel bed to the tubes.

There are three factors that influence the transfer of heat by convection: first, temperature; second, density; third, velocity. At one time it was thought that temperature was the only factor that needed consideration; but the possible effect of the other two factors was suggested a number of years ago (1874) by an English scientist, Professor Reynolds. Since then, his ideas on the subject have occasioned much study, discussion and experimentation, although scien-

build up a cold and insulating layer of gas film, next to the tube surfaces. As gases do not radiate heat, this cold film offers a very effectual resistance to the passage of heat from the body of the gas flowing through the tube. In order to overcome this resistance, it is necessary to tear away this cold, non-conducting film, to give the hot molecules of the gas access to the heating surfaces. The scrubbing and scouring action necessary to break down this film can only be obtained by getting a high velocity of gas flow. At low velocities, the tendency of a gas is to travel in straight, parallel strata (or "stream-lines") of flow, unbroken by eddying currents. As the velocity of the gases increases, this stream-line flow shows a tendency to break up. At a certain point, called the "critical" velocity, violent eddying of the gases takes place and the smooth stream-line flow disappears. It is not difficult to imagine how, under the influence of this stream-line flow, a cold, insulating layer of gas could be built up next to the tube heating surfaces; nor is it difficult

to imagine how the high velocity and violent eddying of the gas currents, would tend to tear down this cold layer of gas and give the hot gas access to the heating surfaces.

This critical velocity is dependent upon the temperature of the gases and the diameter of the tubes. As the temperature of the gases increases, the critical velocity increases; and as the diameter of the tube increases, the critical velocity seemingly decreases. From this last statement it might appear that an increase in the diameter of the tubes would be of advantage, but such is not the case.

As stated before, the amount of heat given off by the gases (other things being equal) depends upon the number of blows that the molecules of gas strike against the heating surfaces. As the gases flow through the tubes the molecules are vibrating rapidly from side to side. This molecular vibration increases as the temperature increases, but the number of contacts made by any one molecule against the tube surface will depend not only upon the velocity of its movement from side to side, but also upon the average distance it has to travel from the body of the gas to the heating surface. It is obvious that by increasing the diameter of the tubes, we increase the average distance that each small particle of gas has to travel, in order to come in contact with

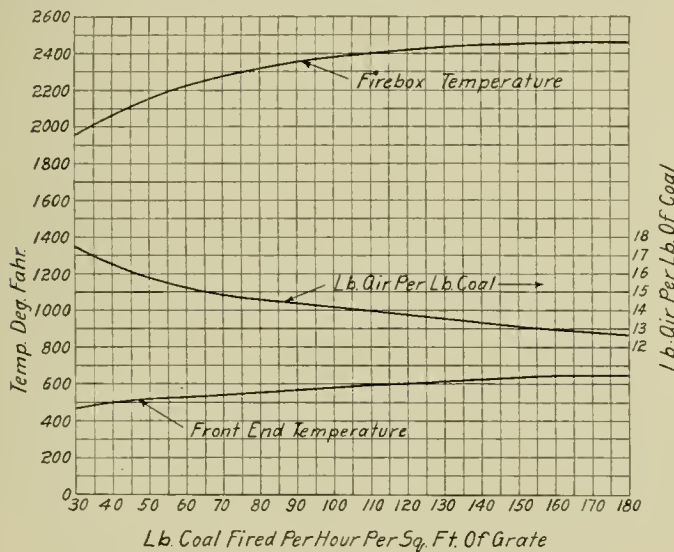

Fig. 3—Air Supply and Temperatures

the tubes; and thereby decrease the number of contacts and the amount of heat transferred.

Tube efficiency increases as the diameter decreases and as the length increases; but not in direct proportion to the increase in length. With each successive increase in length, the heat absorption becomes proportionately less, and there is a stage easily reached at which any increase in tube length gives an imperceptibly small increase in efficiency. Tests made abroad and tests made by the Pennsylvania Railroad at Altoona indicate that a tube length of from 100 to 110 times the internal diameter is best adapted to combine free steaming, high capacity and efficiency. It is probable that efficiency of tube heating surfaces can be best increased by reducing the diameter of the tubes rather than by increasing their length. The problem is to get every molecule of the hot gases into intimate contact with the tube heating surfaces, and the smaller gas passages offer greater opportunity for each particle of gas to come into contact with the heating surfaces and give up its heat.

The tubes now used as standard by the American railroads are 2 in. and 2¼ in. diameter. There would no doubt be objections raised to a reduction in diameter, partly on the score of increased tube blowing, due to the liability of the smaller tube to become filled and plugged with cinders and slag. Such would be the case with the

present design of firebox, but the smaller and shorter tubes should be used in conjunction with long combustion chambers. The increased firebox efficiency to be had with a firebox of ample size, with efficient baffling and gas mixing devices and a long combustion chamber, would result in such a great reduction of the trouble due to sparks, cinders, slag and honeycomb, that smaller tubes could be run with probably less trouble than is had with the present sizes.

If the present size of boiler shell were adhered to, a reduction in the diameter and length of tubes would result in a reduction of the total heating surfaces. Such a reduction in heating surfaces does not necessarily mean a reduction in boiler efficiency or capacity. The capacity and efficiency of our modern locomotive are chiefly limited by the ability of the firebox to burn the coal and liberate the heat contained, not by the ability of the heating surfaces to absorb the heat.

Tests indicate that there is a rapid drop in the efficiency of the tube heating surface, as the velocity of the gases increases from zero up to the point of critical velocity. Once this point is reached, however, the efficiency line becomes almost horizontal, dropping but little with the continued increase in velocity of the gases and increase in evaporation. While the tests mentioned are not conclusive, they seem to indicate that the tube heating surfaces can be forced to a much higher capacity than is now common practice, without decreasing the efficiency to any great extent. The curves in Fig. 2 seem to bear this out. There is a slight drop in the heating surface efficiency as the rate of evaporation increases; for in order to evaporate more water per unit of area, it is necessary to increase the rate of heat transfer to the heating surfaces. This calls for an increase in temperature drop from the fire side to the water side, or an increase in temperature of the fire side of the tube. Such an increase in temperature of the heating surface necessarily increases the temperature of the gases escaping and results in a slight decrease in heating surface efficiency.

UNAVAILABLE HEAT

By the term "unavailable heat" is meant that portion of the heat contained in the gaseous products of combustion that is not available for absorption by the tube heating surfaces, even though such surfaces were 100 per cent efficient. These heating surfaces cannot reduce the temperature of the gases below the temperature of the water in the boiler; therefore, the heat required to raise the products of combustion from the atmospheric temperature to the temperature of the water or steam in the boiler is unavailable for absorption by the boiler heating surfaces. As shown in the chart, Fig. 2, this heat loss amounts to about 15 per cent of the total heat contained in the coal, and remains practically constant throughout the range of tests.

The percentage of this unavailable heat depends:

- First—Upon the temperature of the water or steam, which in turn depends upon the pressure;
- Second—Upon the air supply per pound of coal;
- Third—Upon the amount of moisture contained in the air, and the amount of available hydrogen in the coal, which on burning forms water;
- Fourth—Upon the temperature of the front end gases;
- Fifth—Upon the temperature of the superheated steam flowing through the superheater units.

Any increase in boiler pressure means an increase in steam temperature, and this increases the amount of heat in the gases unavailable for absorption. From the standpoint of boiler efficiency, lower boiler pressures are desirable; but the demand for capacity is so great that a reduction of boiler pressure is almost out of the question.

If, at any given rate of combustion, we increase the air supply, there is a corresponding increase in the amount of heat contained in the gases that is unavailable for absorption. While the total amount of heat in the gases might be

the same, the temperature of the gases is reduced and the ratio of steam temperature to front end temperature is increased, thereby increasing the percentage of unavailable heat. If, at any given rate of combustion and fixed air supply, the front end temperature is increased, the amount of heat contained in the escaping gases is increased, but the ratio giving the percentage of unavailable heat in the front end gases will be decreased. Fig. 3 indicates that as the rate of combustion increases front end temperatures increase and the air supply per pound of coal decreases. The latter partly offsets the increased loss caused by the former, the percentage of unavailable heat remaining almost constant.

Most of the heat contained in steam escaping at the front end (formed by the evaporation of moisture in the air and burning hydrogen in the coal) is unavailable for absorption, because the larger part of the heat so contained is absorbed in evaporating the water into steam. This heat of evaporation is not available and cannot be regained unless the temperature of the front end gases can be reduced sufficiently to cause the steam to condense. At atmospheric pressure the steam would not condense until reduced below 212 deg. F. Since it is impossible to reduce the temperature of the gases below the temperature of the steam or water in the boiler, it follows that in a locomotive boiler equipped with a fire tube superheater it is impossible to reduce the temperature of that portion of the gases coming in contact with the superheater units below the temperature of the steam in those units. With a boiler pressure of 200 lb., the temperature of saturated steam would be 388 deg. The temperature of the superheated steam entering the header might possibly be 650 deg., and it would be impossible to reduce the gases in contact with a part of the units below this temperature, therefore, the amount of heat unavailable for absorption would be increased. This would increase the front end temperatures and reduce overall boiler efficiency.

The advantages of high degree superheat outweigh the advantages of slight increase in boiler efficiency to such an extent that a reduction in heat losses due to this source seems hardly worth considering.

It is evident from the above that the utilization of this "unavailable" heat is not within the province of the boiler proper, and a reduction in the amount of heat so lost can only be brought about by the use of auxiliary apparatus. Front end superheaters and feed-water heaters have been tried out with very little success. The front end superheater has been discarded, because of the very low degree of superheat obtainable and on account of maintenance troubles. The front end feed-water heaters so far tried out have not been highly satisfactory, but the fact that virtually one-seventh of all the heat contained in the coal is unavailable for absorption by the boiler surface and can only be made use of by the adoption of auxiliary apparatus offers a large field for inventors and designers. This front end heat loss is entirely independent of the loss caused by the discharge of exhaust steam which is used for draft-producing purposes. The possibility of using part of the heat from this exhaust steam for heating feed-water has been recognized and a feed-water heater of the "film" type is now being developed for this purpose.

#### SCALE AND SOOT

Nothing has been said about the possible effect of scale and soot upon heat transmission and boiler efficiency. It has been very difficult in the past to secure accurate data showing the effect of scale or of soot upon the transmission of heat. There is no doubt, however, that any accumulation of foreign substances upon the heating surfaces does interfere with heat transmission and does increase the heat losses. All the time and attention given to boiler washing and tube cleaning will be more than repaid by the fuel saving, to say nothing of the reduction in boiler repairs and engine failures.

#### CIRCULATION

The circulation of water around the heating surfaces is of prime importance. Dead water spaces and steam pockets must be avoided, from a standpoint of safety as well as efficiency. The circulation should be at least sufficient to keep the steam bubbles swept away from the heating surfaces, and higher velocities are desirable; but from an efficiency point of view, velocity of circulation is not of first importance. The heat-absorbing capacity of water is so high that comparatively little difficulty is experienced in transferring heat from the wet side of the heating surfaces to the water. The boiler plates offer comparatively little resistance to the flow of heat from the dry surface (or fire side) through to the wet surface (or water side). The main difficulty lies in getting the heat out of the coal and into the heating surfaces.

#### SUMMARY

The hauling capacity of a locomotive is dependent upon the ability of the boiler to furnish steam.

The capacity of the boiler is limited by the ability of the firebox to liberate the heat contained in the coal fired.

The capacity of the firebox and grate is reached much sooner than the capacity of the heating surfaces.

The low boiler efficiency at high capacity is due to the inability of the firebox to properly burn the coal, not to the inability of the heating surfaces to take up the heat.

The largest field for improvement lies in the firebox. Large grate areas and moderate rates of combustion are essential for capacity and efficiency.

Coal cannot be burned economically at high rates of combustion. The evaporation does not keep pace with the amount of coal fired. Increasing the rate of combustion from 30 to 180 lb. means that we are burning six times as much coal but evaporate only three times as much water.

Ample air supply is absolutely essential. Ashpan air openings should be large enough to prevent any pressure drop in the ashpan. Air openings through grates should be as large as physical characteristics of the coal permit. It is not necessary to throttle the air at the ashpan or grate, the fuel bed will take care of this.

A large percentage of bituminous coal burns as a gas, and provisions must be made for properly burning this gas. Refractory baffles, mixing devices and long combustion chambers are essential.

Firebox evaporation depends upon the area and temperature of the radiating surfaces—that is, fuel bed, brick work and flames.

Firebox heating surface is incidental to the size of grate and volume of combustion chamber space.

The efficiency and capacity of the boiler are not governed by tube length nor the extent of tube heating surfaces.

Increasing tube length beyond 100 times the internal diameter gives but little increase in efficiency or capacity.

The efficiency of a tube increases as the diameter decreases. The heat can best be extracted from the gases by breaking them up into small streams.

The efficiency of a tube decreases slowly, after the gases reach the point of critical velocity. Their capacity can be greatly increased after this point is reached, with a very small decrease in efficiency.

The present heating surfaces of both firebox and tubes are not being forced to their capacity.

Grates and combustion chamber space are being forced beyond their capacity.

The efficiency of the firebox can be increased by providing larger grates, refractory baffles, gas mixing devices and longer combustion chambers.

If necessary to reduce the tube lengths below 100 times their present diameter, in order to accommodate the longer combustion chamber and larger grate, the diameters can be decreased proportionally and the efficiency maintained.

# PRESENT DAY LOCOMOTIVE PROBLEMS\*

A Few of the More Important Phases of Design and Operation Greatly in Need of Attention

BY GEORGE M. BASFORD †

WHEN this club began (1901) the biggest locomotive in the world was, I believe, a Consolidation running here in Pittsburgh. For a long time after that locomotives ran to size and weight. It was easy to make them bigger and heavier. But a far greater and more difficult as well as more important problem faces us today. It is the problem of forcing every pound of weight to justify itself in terms of power to serve mankind. Who has a bigger, nobler opportunity and duty than this?

When our club began, officials wouldn't listen, as they do now, to consideration of improved efficiency. Superheaters, brick arches, combustion chambers and feed water heaters are old. Their real application to our great problem came but six years ago, and they are only now beginning to be really used in this problem. Today officials are reaching out for new things and old things in new application. They eagerly seek capacity increasing factors. Why? Because they are facing the question of increased weights in equipment and in operation. They need more power per unit, to do the world's business and do it economically.

Therefore young men never had the opportunity or the duty that they have facing them today. Do they realize it?

Let us make a little list of big possibilities in locomotive development to show what lies before young railroad men right now. The items are mentioned at random, not in order of importance.

*Boiler Design as a Whole.*—Size is only one part of this problem instead of being the chief feature as it has been considered in the past. It is now a question of balancing all factors to make and to absorb the maximum amount of heat per unit of weight. The day of ratios between grate area, heating surface and cylinder volumes has given place to a day of providing steam to produce definite amounts of cylinder horse power within defined limits of weight. This is revolutionary and the corralling of many a fractious heat unit must be made possible.

*Boiler Circulation.*—Many a bright mind is engaged in improving the movement of the water in the boiler with the promise for the future. Very little positive information is available now upon this subject. Who will put us straight on the matter of boiler circulation?

*Improved Grates.*—Grate design is now being studied as it never has been before. Experimental developments in grates as to air openings and grate construction promise valuable improvements in the near future. Conditions requiring maximum power lead to the conclusion that air openings through the grates should be as large as the character of the coal used will permit. Thirty per cent is aimed at. Recognition is waiting for a thoroughbred grate expert. The largest Pacific type passenger locomotive has 47,500 lb. tractive effort and the same grate area that was used in the same service six years ago when the tractive effort was but 32,900 lb. This problem is a worthy one for that expert. What is he going to do about it?

*Ash Pan Design.*—This is a vital factor in the production of heat. To provide air sufficient for intense combustion is the object of experiments now being conducted which promise a simple solution of this problem. To provide air enough for a big firebox and put the air where it is wanted is no child's play. The speed of gases at a certain point in a big

firebox, working hard, is 200 miles per hour. Who is the expert who will point the way to the ash pan design to supply air enough and how will he provide air openings in the ash pan sufficient to maintain atmospheric pressure in the ash pan at maximum rate of power development?

*Combustion: Engineering Applied to Firebox Design.*—The purpose is to attain, with all fuels, the highest degree of heat intensity per unit of firebox volume. Here is where the energy is developed. This is the heat factory. It is worthy of a lifetime study. Important developments are nearly ready to be announced. Your field is nearly 70,000 fireboxes.

To burn the gases completely before they reach the flues and to accomplish this in the big firebox is another big problem. This involves grates, arches, air admission below and directly into the fire and mixing of the burning gases by division into small streams. It also involves the shape and size of the firebox and combustion chamber. All this is now being worked out on paper and in practice. Recent studies in firebox design recognizing the great importance of heat radiation and the relatively small importance of transfer of heat by convection have revealed the firebox problem in a new light. This will result in larger fireboxes, larger grates, larger combustion chambers and in new developments in the mixing of the burning gases by improvements in brick arches. Improvements already tried experimentally promise remarkable results. With all this to do, the field for combustion experts is very far from being over crowded. Before long 100,000 fireboxes will be in service to keep this country going. A little improvement applied to each of these will save a mountain of money.

It is known that a certain sacrifice of tube heating surface for the benefit of increased firebox volume in the form of a combustion chamber is justified but how far should this be carried? This should be investigated. Then there is the question of tube length.

*Front End Draft Appliances.*—Here is another field of promise. To produce the pump action necessary for draft with minimum back pressure load on the cylinders will bring great credit to the one who is successful in working it out. Why should front end construction that itself consumes 33 per cent of the draft produced be perpetuated?

*Detail Design.*—Developments in details to enable locomotives to run between shoppings with minimum running repairs present interesting possibilities. Shoes and wedges, journal boxes, hub liners, long driving boxes, improved throttles, lubrication, engine truck, trailing truck, tender truck design, also improved couplings of locomotives to tenders and radial motion for front and rear driving axles of long wheel base locomotives all bear on this question.

*Tender Design.*—Tenders may be said to have been somewhat overlooked in the speed of going to heavier and more powerful locomotives.

*Labor Saving Devices.*—Here is a definite line for development which is well started in power reverse gear, power operated firedoors and grate shakers and coal pushers, also the greatest of all these devices, the mechanical stoker. All these factors are needed because of the increased size of the locomotive. This renders it necessary to provide power auxiliaries to take the place of physical strength and endurance. Then locomotive operation becomes a matter of brain work rather than brute force.

*Improved Valve Motion.*—Great strides in this direction in ten years give encouragement to the hope that there is

\*From a paper on Railway Clubs and Young Men, presented at a meeting of the Railway Club of Pittsburgh, Friday evening, September 22, 1916.

†President, Locomotive Feed Water Heater Company, New York.

more improvement to come. How crude the valve gear of the past would look on a big modern locomotive from the standpoint of convenience, let alone the question of economy in performance and the possibility of standardizing construction! Imagine yourself crawling under the wheels of a big modern locomotive to get at the eccentrics!

*Superheating.*—This improvement is by no means finished. Those who are living with this problem are in position to lead still further in their influence on cylinder performance and in the effective use of the heat from the firebox. Superheating engineers are ready to give higher superheat when railroads are prepared to use it by improvements in operation and maintenance. Great economies are available in higher superheat through increase in volume of the steam. These engineers are also ready to put to good use any increase of firebox temperature the combustion engineers can give them. Superheating, the greatest improvement the locomotive has ever seen, is not finished. It offers still greater possibilities when you are ready for them.

*Feed Water Heating.*—This is now a factor in locomotive engineering and operation. It promises to take a place next to superheating in improving economy and increasing capacity with the incidental advantage of prolonging boiler and firebox life and reducing cost of boiler maintenance. Successful feed water heating means increased boiler power. It will permit of modernizing existing boilers of outclassed locomotives to render them available again in many cases for service which has outgrown them. Feed water heaters may be applied to existing locomotives under a charge to capital account and for a number of years will defer charges to operating account for replacing those locomotives by new ones. Feed water heaters will increase evaporation per pound of coal and provide economy not available in any other way because the improvement is made from otherwise wasted heat. Locomotive boilers should be relieved of the duty of heating water. It should come to them hot, leaving only the evaporation to be effected in the boiler. Feed water heating is not new but successful locomotive feed water heating in this country has but just now been accomplished. A little later there will be more to be said on this subject. This development has been waiting for the successful heater.

*Compounding.*—This principle is coming to its own. No locomotive improvement fills its natural field so well as when it is properly fitted into the general scheme of locomotive design as the compound feature is fitted into the Mallet.

*Water Purification.*—This becomes more important every day. Before long people whose lives have been made miserable by water unfit to use in boilers of any kind will wonder why they ever used it in the most rigorous boiler service in the world. They will wonder why they ever paid the boiler repair bills of the past when the remedy is so easy and the returns so great. Let some of the young men tackle the problem of improving means and methods of water purification.

*Brake Shoes.*—Do you remember any illuminating paper on the subject of brake shoes within a year or two before any of the clubs? Here is an inspiring, live, subject—this and the clasp brake. It would be specially appropriate for this club to record brake and braking progress as a whole in a fitting manner and tell the railroad world what it is missing and what it ought to do.

*Air Brakes.*—So great have been the improvements in means of stopping trains that the authorities of a few years ago have now new subjects to study if they would keep abreast of progress. The electric control and the automatic adjustments are distinctly revolutionary in their effect on the capacity of railroads as well as on the safety of travel. The capacity of some very important railroads is specifically a question of brakes. Do the railroads know what they ought to do next in air brakes?

*Powdered Fuel.*—Herein lies a possibility of the use of heretofore impossible fuels with a \$250,000,000 annual steam locomotive fuel bill to work on, also the possibility of increased steam making capacity and perfection of firebox operation that until recently were not hoped for. Increased hauling capacity and continuity of locomotive operation and eliminating of ash pit delay offer great promise for the future. Increased boiler capacity is a question of producing maximum calorific intensity per cubic foot of firebox volume. This is the raw material for the heating surface and superheater to work with. Speaking in general terms pulverized fuel will transform an 80 per cent boiler into a 100 per cent boiler. Consider what this would mean to say 30,000 locomotives in this country that are deficient in boiler capacity. Here again a capital charge will put from five to ten years of new life coupled with increased capacity into a lot of old power. It will put many an outclassed locomotive back on the main line. The chief reason for buying new locomotives is to get boilers that are big enough to haul maximum tonnage over ruling grades. Increased boiler capacity resulting from fuel efficiency is the question answered by pulverized fuel. It has already shown a boiler efficiency of 77 per cent with pulverized Kentucky unwashed screenings, as compared with 61.1 per cent with lump coal from the same mine hand fired in the same locomotive.

*Alloy Steels.*—If you could see confidential figures now in the desk of your speaker some of you would jump to the task of improving locomotive design with respect to lightening reciprocating and revolving parts of locomotives. This means making every pound of weight work for you. It includes possibilities in locomotives and tender designs as well as parts of running gear. It is difficult to understand how the possibilities of improved use of a pound of weight rendered possible by improved detail design of running gear could have been overlooked so long. Your speaker has recently given three years to this study and is in position to state that there is an insistent need of brain work followed by action in this field. There is not a minute to lose in taking up the light part and counterbalance questions and the reduction of dynamic augment by improved designs and alloy heat treated steels.

*Signaling.*—This has become a matter of speed control and increased capacity of track as well as a safety provision. Wonderful strides are being made in this field that are not widely known or well understood. Signaling is seldom mentioned before the various railroad clubs. It will have an important effect upon the operation of locomotives in the near future.

Do you want more things to do? Then get into locomotive operation. Work out plans for keeping expensive locomotives in service a larger portion of the day. An average figure representing present practice is 4 hr. 19 min. actual service out of a 24-hour day. Get into questions of organization, selecting, training and promotion of men. Who will wake up the railroads to the suicidal policy of neglect of the selection of recruits and of training these recruits in all departments? Take up the question of railroading as a business with real cooperation of all departments. Study suitability of locomotives to their working conditions. Who will show railroad managers how much money may be made in suitable roundhouses and in shops and shop equipment for maintaining big engines? No specific mention of the details of the car problems can be made on this occasion but the car offers opportunities that are little less important than those of the locomotive.

Best locomotive records, reflecting up to date developments show a water rate of 14.6 lb. per indicated horse power hour. What may be termed unimproved locomotives produce this unit on about 24 to 30 lb. Between these figures lie great possibilities. Between them lies your opportunity. The majority of locomotives are in or near the 24 lb. class



# Car Department

## CABOOSE FOR THE N., C. & ST. L.

The Nashville, Chattanooga & St. Louis on its Chattanooga division passes over the Cumberland mountains. Pusher service is required to get the tonnage trains over this grade. With the installation of the Mikado locomotives on this division the tonnage of the trains has been materially increased and Mallet locomotives having 99,000 lb. tractive effort have been installed to push them over the mountain. This has made necessary the construction of 30 cabooses of sufficient strength to be used ahead of the Mallets. They were designed and built at the company's shops at Nashville, and have substantial steel underframes, steel frame

the full length of the car and under the striking castings. They are spaced 127 $\frac{3}{8}$  in. from back to back, the flanges being turned outward, and are covered for their full length by a top cover plate 21 in. wide by  $\frac{1}{2}$  in. thick, which extends over the body bolsters. The bottom cover plate is of the same material and extends between the bolsters. The center sills are connected at each crossbearer by a 12-in. channel spacer connected to each center sill by one 4-in. by 4-in. by  $\frac{3}{8}$ -in. angle. The two crossbearers are made up of  $\frac{3}{8}$ -in. web plates bound at the top and bottom on each side by 3-in. by 2 $\frac{1}{2}$ -in. by  $\frac{1}{4}$ -in. angles. They are connected to the center sill by two 4-in. by 4-in. by  $\frac{3}{8}$ -in. angles and to the side sill by two 6-in. by 4-in. angles. The side sills



Steel Frame Single Sheathed Caboose for the N. C. & St. L.

superstructures and are of the single sheathed type. They weigh 41,000 lb. each and have the following dimensions:

Length over striking castings.....	37 ft. 8 $\frac{1}{2}$ in.
Length inside.....	31 ft. 6 $\frac{1}{2}$ in.
Length between end sills.....	36 ft. 11 $\frac{1}{2}$ in.
Width inside.....	8 ft. 6 in.
Height from floor to top of rail.....	4 ft. 6 $\frac{3}{4}$ in.
Height from rail to top of running board.....	11 ft. 8 $\frac{1}{4}$ in.
Center to center of trucks.....	24 ft. 2 in.
Truck wheel base.....	5 ft. 6 in.
Width of platform.....	2 ft. 6 in.

The underframe is made of structural shapes, the center sill consisting of two 15-in., 33-lb., steel channels extending

are 8-in., 11.25-lb., channels extending the full length of the car between the end sills, being connected to them by the 5-in. by 5 $\frac{1}{2}$ -in. by 5/16-in. corner post angles. The end sills are made of the same material and extend the full width of the car. They are connected to the center sill by 5/16-in. gusset plates and the striking castings. The body bolsters consist of steel castings which extend between the center and side sills. They are the same as those used on the road's 80,000-lb. capacity box cars. A cover strap riveted to the top of the bolster passes over the center sills, securely tying together

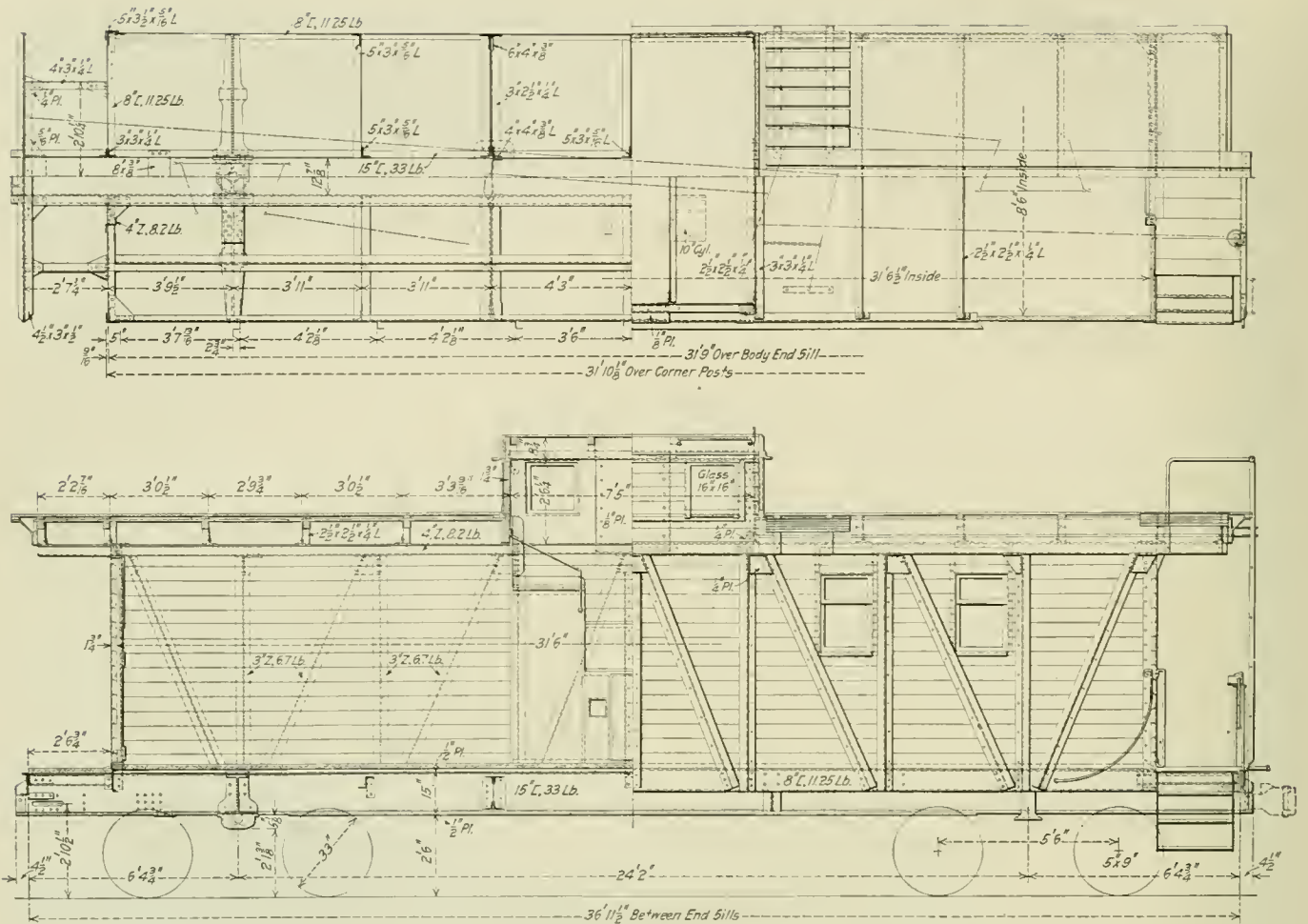

Plan and Elevation of the Caboose Cars

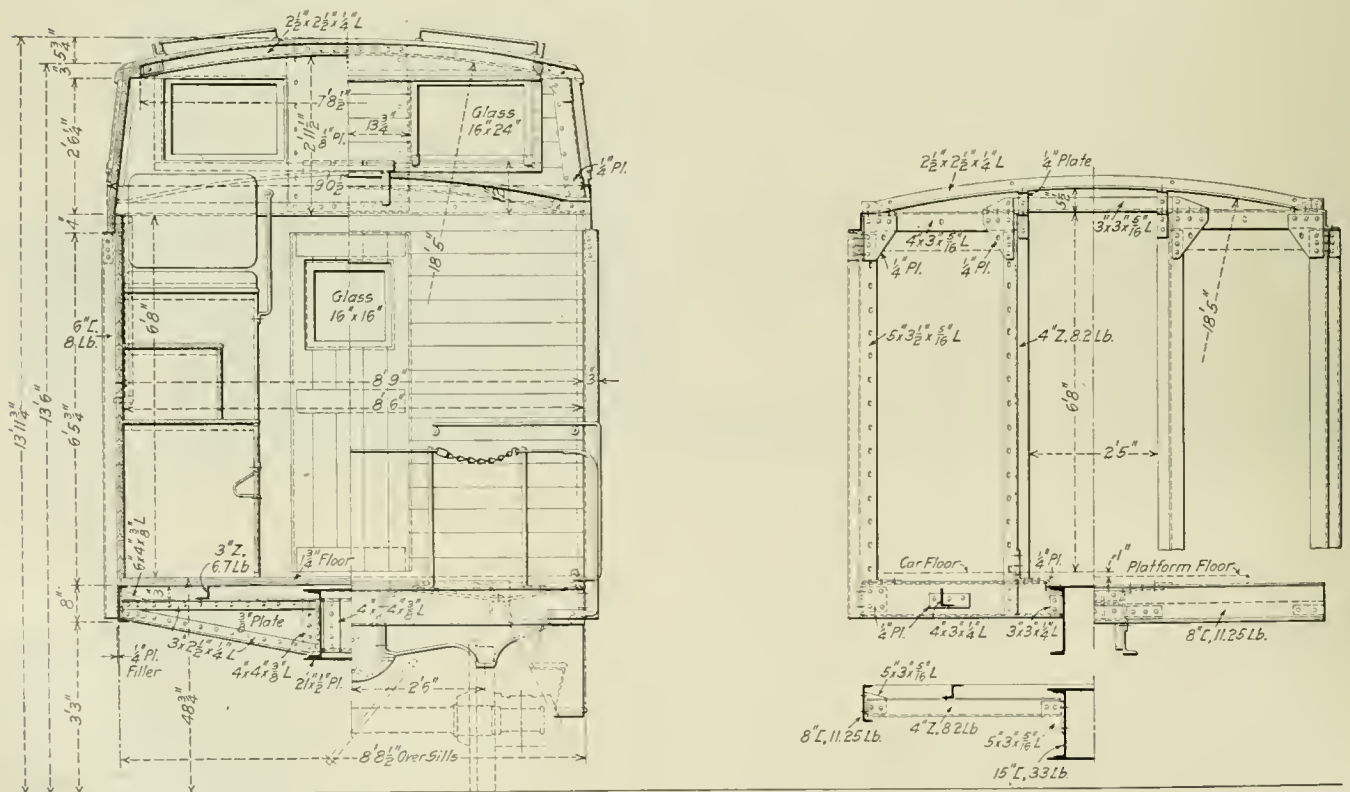

End Elevation and Sections of the N. C. & St. L. Caboose Cars

the body bolsters on each side of the sills. The connection between the center sills at the body bolster is made by a steel truck center casting. There are three floor beams per car which consist of 4-in., 8.2-lb., Z-bars fastened to the center and side sills by an angle bar. The floor stringers consist of two 3-in., 6.7-lb., Z-bars extending between the end posts and fastened to the end sill.

The framing of the car is similar to that used in the

The trucks have a wheel base of 5 ft. 6 in., 5-in. by 9-in. journals and 33-in. wheels. The truck side frame is of the Scullin type with the Sullivan flexible spring plank. This spring plank, which is shown in one of the drawings, is the invention of J. J. Sullivan, superintendent of machinery of the N. C. & St. L., and was designed for the purpose of making an equalized truck, distributing the weight equally on all journals regardless of the track conditions. It will be

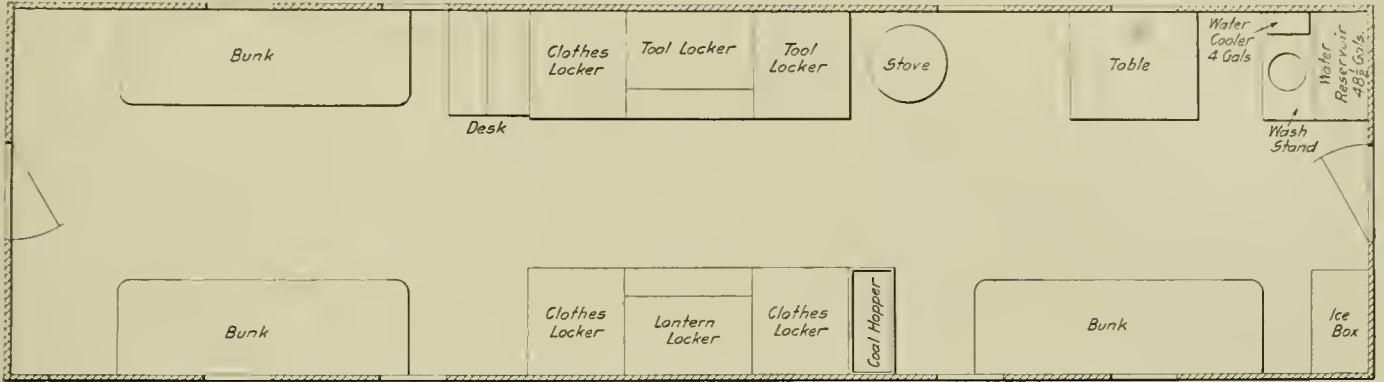

Floor Plan of N. C. & St. L. Caboose Cars

80,000-lb. capacity box cars. The side posts and braces consist of 3-in., 6.7-lb., Z-bars which are riveted to the side sills and are connected to the side plates by 1/4-in. steel gusset plates. The end posts consist of 4-in., 8.2-lb., Z-bars which are riveted to the end sills and are connected to the end plates by angle bars as shown in the drawing. The corner posts are 5-in. by 3 1/2-in. by 5/16-in. steel angles. The side plates consist of 4-in., 8.2-lb., Z-bars and the end plates are 4-in. by 3-in. by 5/16-in. angles. Both the side plates and end plates are riveted directly to the corner post angles. The carlines are made of 2 1/2-in. by 2 1/2-in. by 1/4-in. angles filled with 2 1/2-in. by 2 1/2-in. filler blocks to

noticed that near the ends lugs are formed 1 3/8 in. deep, 2 in. wide and with a radius of 8 in. These rest in corresponding grooves in the lower member of the truck frame. With this construction the truck is less liable to derail under rough track conditions than the rigid truck where the weight shifts diagonally on the journals. The truck springs are of the triple elliptic type.

The cars are equipped with the Miner friction draft gear,



Interior of the N. C. & St. L. Caboose Cars

which is nailed the roofing. The lining is 1 1/2-in. tongued and grooved yellow pine having a 5 1/2-in. face on all except the top board, which is 8 3/4 in. The roof lining is 13/16-in. yellow pine. It is covered with Follansbee slow process tin. The flooring is ship-lapped yellow pine 1 3/4 in. thick with a 7 1/4-in. face. The flooring is secured to the steel stringers by 1/2-in. carriage bolts. The cupola framing is built up of steel plates and angles. The conductor's valve may be operated from the outside on both ends of the cupola and from either of the interior cupola seats.

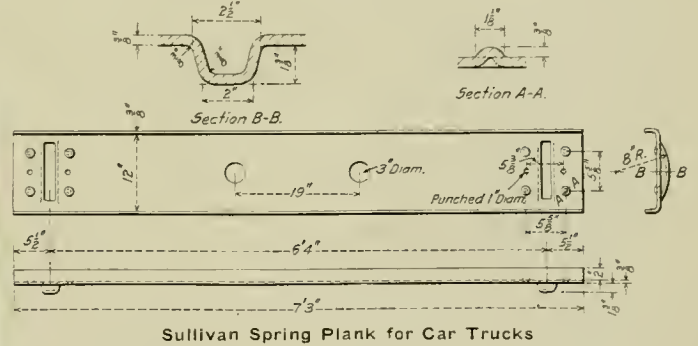

Sullivan Spring Plank for Car Trucks

Westinghouse schedule K.C. 1012 air brakes, Sharon cast steel couplers with 5-in. by 7-in. shank, and the National Malleable Castings Company's journal boxes. The Master Car Builders' standards have been used extensively throughout the entire car.

### BELT RAIL APPLIED TO UNION PACIFIC ALL-STEEL AUTOMOBILE CARS

The Union Pacific has 600 all-steel automobile cars which were built with the sheathing inside the frame. They were provided with no means of securing shoring for the lading other than the wooden floor, no provision being made for nailing wooden blocks to the side walls on the interior of the car.

A thorough investigation was made of the various methods employed by automobile shippers for applying double deck loads. It was found that each automobile shipper has his own system of double decking, all of which provide for the making up and carrying in stock of certain sizes of timbers and blocks suitable for application to any wood lined automobile car. When the shipper wishes to double deck a car he picks out the several pieces which enter into the construc-

tion of the deck, all cut to size, and secures them to the interior of the car by nailing to the sides. The all-steel automobile cars did not afford nailing facilities on account of the steel lining and the wooden belt rail and floor stringer shown in the drawing were designed and applied to a car.

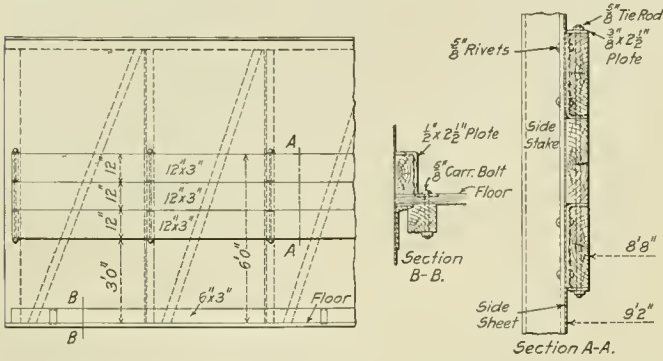

Wooden Belt Rail and Floor Stringer for Union Pacific All-Steel Automobile Cars

This was passed upon by the shippers and was found to be satisfactory from the standpoint of automobile loading. It is also an advantage in loading other commodities, as it provides means for blocking bulky freight. The arrangement is now being applied to the rest of these cars.

gauge for checking this distance would seem to be the practical means of insuring that the wheels are located symmetrically on the axle when the distance between the wheels is correct. The gauge is not intended to space the wheels, but merely insures the proper location of the first wheel relative to the journal, the other one being spaced from this in the usual manner.

Referring to the details of the gauge, it will be seen that there are three adjustable contact points, two of which are designed to be placed against the flange of the wheel at

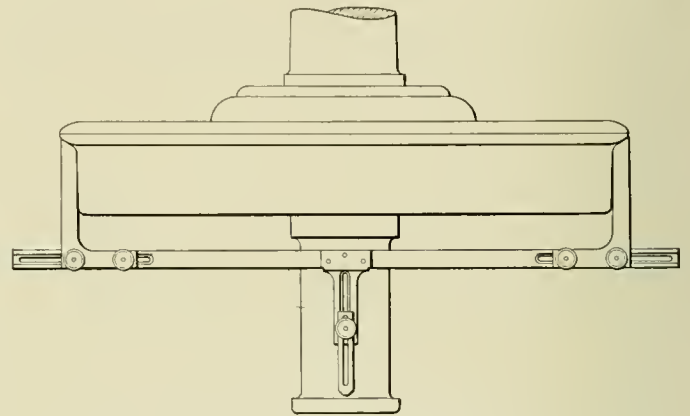

How the Gauge Is Applied

diametrically opposite points. These are adjustable on the body of the gauge and may be set to suit the diameter of the wheel. The body is offset in the center to clear the journal and here is attached the third point, which is adjustable in a direction parallel to the center of the axle and is designed to be brought into contact with the inner face of the journal collar. The method of using the gauge will be readily under-

### GAGE FOR CHECKING THE LOCATION OF WHEELS ON THE AXLE

BY HOWARD W. STULL

Machine Shop Foreman, Philadelphia & Reading, Pa.

A wheel gage has been designed at the Philadelphia & Reading car shops for use in checking up the location of wheels after they have been pressed on the axle, to determine if the distance between the flange and the journal collar is

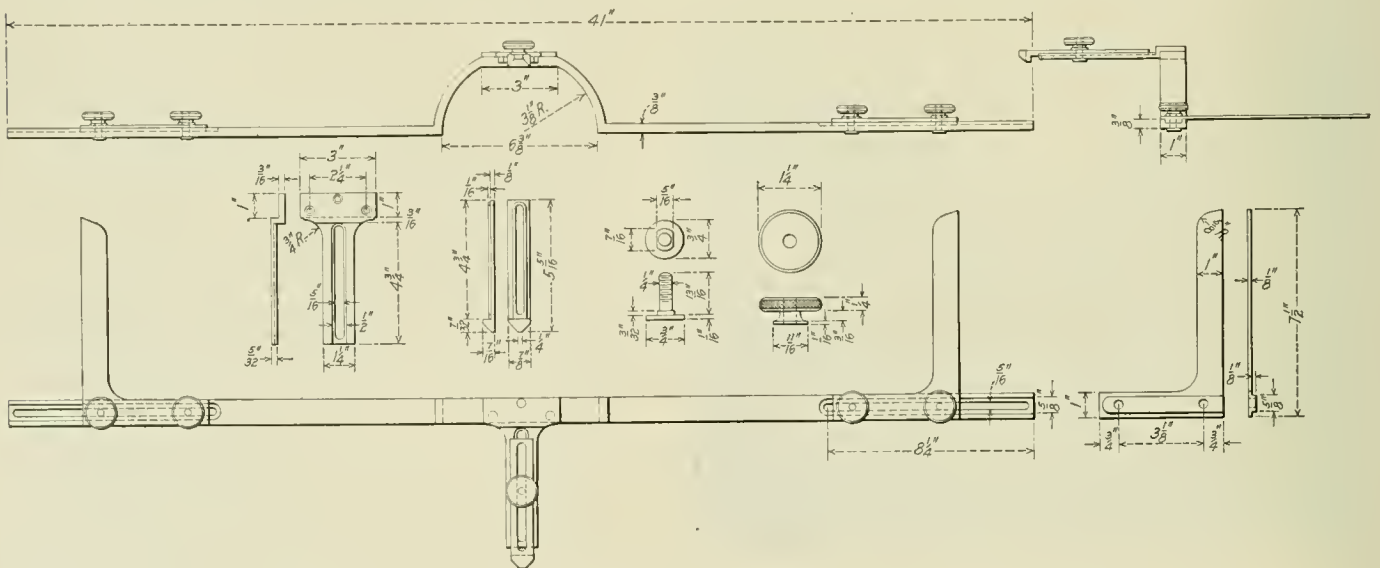

Details of the Gauge for Determining the Proper Location of Wheels on the Axle

the same at both ends. Many train delays are caused by hot journal boxes and this is often claimed by the car inspectors to be due to the fact that the wheels are not properly located on the axle, the wheel at one end being pressed on too far, while that at the other is not pressed on far enough, thus causing excessive pressure of the collar against the brass at one end and of the fillet at the other. An inspection of the wheels often seems to bear out this claim, as we find that the distance between the journal collar and the flange varies as much as  $\frac{3}{8}$  in. to  $\frac{7}{8}$  in. on the same pair. The use of a

stood by referring to the drawings, one of which shows the gauge applied.

MOTOR CARS TO ARCHANGEL.—According to a wireless press message, the Russian military authorities have started a complete service of motor-cars between Petrograd and Archangel to supplement the railway. The road from Petrograd to Archangel, over 600 miles in length, has been newly constructed for the purpose. The cars, most of which are heavy lorries, were supplied from the United States.

# CAR AND LOCOMOTIVE PAINTERS

Subjects at Annual Meeting Included Paint Specifications and Steel Passenger Equipment Roofs



**T**HE forty-seventh annual convention of Master Car and Locomotive Painters' Association of the United States and Canada was held at the Breakers Hotel, Atlantic City, N. J., September 12-15, H. Hengefeld, master painter of the Atlantic Coast Line, presiding. The association was welcomed to Atlantic City by a representative of the mayor and the key of the city delivered to the president. In his address, President Hengefeld dwelt on the relations of the members with their superior officers and laid stress on the need for economy under the present conditions affecting wages and the price of materials. The secretary-treasurer reported a membership of 305, which is a gain of 13 over last year.

## REPORT OF TEST COMMITTEE

The Committee on Tests, of which J. W. Gibbons (Santa Fe) is chairman, presented a report from which the following is taken:

The committee last year proved by a number of tests that heat treated linseed oil made the best paint vehicle for the protection of iron and steel. We also gave quotations from a number of recognized authorities on paint to substantiate our claims. To further substantiate the proof submitted, we have secured some paints made with the same pigments, but the vehicle in one set was raw linseed oil and in the other heat treated linseed oil. These paints were applied on sand-blasted steel plates and when dry, the plates were fastened on the roof of a passenger car.

The plates on which the paint mixed with raw linseed oil was applied are badly corroded. The others are in fair condition. A number of the plates were painted with different compositions of red lead and inert materials mixed with the different oils, but we did not have sufficient exposure to secure definite results. Film tests made of these materials indicate that comparatively the same results may be anticipated. These films were allowed to dry for ten months, then submerged in water for 60 days, taken out and allowed to dry for one week, then submerged for 30 days.

All authorities who have studied the question agree that sulphur fumes and acids from the wash and burning of coal constitute the greatest menace to the proper protection of railroad equipment. Therefore, the committee had run

tests to ascertain what composition of paint materials offers the greatest resistance to sulphuric acid. The plates used in this test were each given three coats of paint and when thoroughly dried a 40, 50, 60 and 70 per cent solution of sulphuric acid was dropped on the paint.

This completes a series of tests to determine the relative merits of paint materials for the protection of steel and we believe we have conclusively proved that (1) a heat treated linseed oil is superior to raw or chemically treated linseed oil. (2) Considering service conditions, and price, a composition paint with red lead base is the best paint for priming or under coating, although more or less susceptible to the action of acids. (3) Carbon paints when applied direct to the metal, permit corrosion to form rapidly, but when properly selected and mixed with heat treated linseed oil, make an ideal finishing coat for certain classes of railway equipment, on account of the acid-resisting qualities. [To demonstrate the effect of electrolysis on steel the committee presented a series of photographs showing the interior of a treated water storage tank of the Santa Fe at Topeka.]

## DISCUSSION

It was brought out in the discussion that red lead with from 10 to 15 per cent of litharge will give the best service in painting steel cars. The Norfolk & Western has tried pure red lead and has had to purchase litharge to mix with it, in order to get the proper drying qualities. It was the consensus of opinion that the best results in painting steel cars required the removal of all rust.

## TREATMENT OF STEEL PASSENGER EQUIPMENT ROOFS AND DECKS

H. HEFFLEFINGER (Penna.).—Before any steel surfaces of a passenger car are painted they must first be made free from scale, rust, grease, acid, etc. There seems to be only one way to guarantee a thorough cleansing of these parts and that is by sandblasting, either before or after assembling, as the use of wire brushes, scrapers and sand or emery paper will not reach all the defective places. To procure the best results after the sandblasting, elastic primers should be used and should be baked on, when it is possible to do so.

These primers should be applied to all surfaces where

metal bears on metal before assembling, and all concealed parts, such as the hoods, under surface plates forming the roof, and the ventilators on cars having stationary sash, must receive a second and third coat of paint before complete assembly, preferably by using an approved steel or iron paint of two colors to make sure of safe inspections. The same rule should be followed in painting the top of the roof; that is, it should not receive less than three coats of a well-tried-out elastic mixture.

The decks, deck screens and deck sash should be primed outside and inside with the same kind of material used as a primer on the body. The outside of these parts should then be followed up with two coats of body color (not too flat), and two coats of the same kind of finishing varnish as is applied to the body outside. The painted finish of the inside of the decks and deck sash, after being well primed, depends somewhat on the finish the interior of the body is to have up to the varnish coats.

Omitting this feature, it is evident that to get the maximum wear out of painted surfaces on the interior of steel passenger equipment cars, they must be covered with as slow a rubbing varnish as possible, sacrificing to some extent the finer finish a quicker rubbing varnish would make. Unless this is done a checked surface will develop in a short time.

In my opinion the parts mentioned in this subject must be classed by themselves for the proper treatment and maintenance, for it matters not what condition the paint seems to be on the car body when receiving class repairs, these parts should be thoroughly examined on the exposed or outside portions.

If the roof is badly rusted it should be sandblasted and painted the same as if new. If not badly rusted, it should be gone over with wire brushes and scrapers and given at least two coats of a well-brushed-out elastic paint, the first coat to be applied as soon as practicable after the car is received, so as to allow as much time as possible between coats while the car is held for class repairs.

The deck outside, having stationary steel sash, should be scrubbed and the rust cleaned off with scrapers and wire brushes. A coat of primer should be applied when needed, followed up with two coats of color and varnish, using finishing varnish in the color. The crown moulding on the deck, if curved inward forming a spout-like shape, should be beaten with wooden mallets or clubs to loosen the rust and dirt on the inside before painting. I have noticed in some cases this style of moulding and the face of deck bearers on the ends of the inside of steel passenger cars to be entirely rusted through.

Deck screens must be removed from all cars as they pass through the shops for class repairs, so that they can be thoroughly cleaned and repainted; also to give free access to the deck sides for their proper treatment. They should be replaced before the last coat is applied to the roof, and should receive a coat of finishing varnish after they are in place. Deck sash must be carefully gone over and the loose putty or cement removed, or rust will form on the rails and mullions in a short time.

O. P. WILKINS (N. & W.)—There are three elements that must enter into a proper protection for steel passenger car

roofs, decks, screens, sash, etc., namely, the preparation of the steel, the quality of paint, and the application of the material. No matter how well the surface is prepared, if the right kind of material is not used, the effort is practically lost; and no matter how well we prepare the surface, nor with what care the coating is compounded, if it is improperly applied, we may look for an early failure.

We have more or less trouble in protecting the upper parts of our steel passenger cars, and the main reason is that we have adopted the same method as that employed in protecting locomotive cab roofs; this method, not being a cure-all, did not produce the same results.

The author believes the first operation is to thoroughly sandblast the surface and prime immediately with a first class primer. It is of the utmost importance that the priming be done before the accumulation of any moisture, otherwise the sandblasting would be of little value. Red lead and raw linseed oil have been adopted exclusively as a primer, as a result of tests, for all structural steel. Having primed the roof, when thoroughly dry, apply three coats of high grade roof paint, allowing ample time between each coat for proper drying. For this operation we recommend a pigment of high oil carrying capacity such as lamp-black, graphite, and finely divided iron oxide.

The hood ends are improved and offer greater resistance to the cinders if the last coat of roof color is given a liberal sprinkling of sand.

For maintaining the steel roof, we suggest that it is of paramount importance to have a thoroughly competent man to inspect the roof at terminals, and when he finds the paint film breaking, he should not lose any time in applying a coat of standard roof paint. Employees reicing and watering cars should be required to wear rubber heels on all shoes to prevent the nails from scratching the painted surface.

The metal frames of deck screens should be thoroughly sandblasted, primed immediately with red lead, and this followed up with a good surfacing system in keeping with the other parts of the car. After the priming is dry, apply one coat of surfacer, knife in the rough places, sandpaper, and apply two coats of enamel and one coat of body varnish. For maintenance, we suggest careful, competent inspection at terminals, and when the occasion demands, apply a coat of enamel. The initial treatment and maintenance of deck sash should be in accordance with the other parts of the car.

Ventilators should be kept well painted and protected from the elements. The initial treatment in the case of galvanized iron or tin should first be a coat of red lead priming, and if black iron or steel is used, they should be sandblasted. After the priming coat has been applied, follow in the same manner as in the treatment of the roof already referred to.

J. D. WRIGHT (B. & O.)—The preservation of the roofs, decks, deck-sash, screens and ventilators, on account of the severe exposure to which they are subjected, presents one of the most difficult problems connected with the painting of steel passenger equipment cars. The heat from the sun, moisture from dew, frost, hail, rain and snow, tend to destroy the life of the paint coatings applied for their protec-



H. Hengefeld, President,  
Master Painters' Association

tion. The gases from locomotives, especially in tunnels, are more severe on the roofs, decks, deck screens, etc., than on any other part of the car. The abrasion caused by cinders and in many cases, from the feet of employees while walking on the roofs to fill water coolers, tanks and refrigerators, wears away the protective coatings and in time exposes the metal.

While the subject in hand is on the initial treatment and maintenance of the parts in question, their preservation is so much affected by their construction that it may not be out of place to point out, at the outset, the advantages derived from having plain surfaces to protect, free from corners and pockets where cinders may lodge and collect moisture, and in this manner make dilute acid which acts chemically on the metal wherever it can be reached.

Corrosion of steel roofs, decks, deck screens, etc., is the principal cause of their deterioration and the metal in these parts should be protected adequately from the outset, to prevent the corrosion from getting a start. There appears to be a difference in the formation of the corrosion which takes place on the steel roofs as compared with the rust that forms on steel sheets which are in a vertical position. The former seems to start with a pit which gradually extends its circumference and eats its way deep into the metal, while the rust on vertical sheets remains more on the surface. This is probably due to the fact that on the horizontal sheets the moisture, which is always present when corrosion takes place, hangs in the cavity of the pit and accelerates the corrosive action, while the vertical surfaces naturally dry off more readily. We are also inclined to think that many of the pits on the roofs are started by hot cinders which fall on the horizontal parts, burning through the paint and in this manner exposing the metal.

The steel should, of course, be properly cared for from the time it leaves the mills until the parts are assembled and applied to the cars, and not allowed to rust. During the process of construction, all overlapping joints should be filled in with a thick protective mixture and made watertight. The underside of the roof sheets, the back of all deck sheets, and all hidden parts should be thoroughly cleaned and receive two coats of a good metal preservative paint before being covered up, after which the exposed surfaces are ready for the initial treatment.

important steps in the initial treatment. All oil, grease, dirt, scale and rust should be entirely removed before any coatings are applied for the protection of the metal. Benzine will remove the oil and grease, but the sand blast is by far the best means of preparing the steel for the paint coatings. It not only removes the dirt, scale and rust, but also roughens up the surface of the metal so that the priming coat has a better opportunity to hold to the steel.

After the steel has been sandblasted, the next step is to decide the kind, or kinds of paint to apply and the number of coats. I think we can exclude the entire class known as "tar paints" as being unsuitable for this work. Oil paints will give more satisfactory results, but better still are paints made with both linseed oil and varnish in combination, with sufficient volatile liquid to make them dry and work properly. The addition of varnish to the linseed oil makes a paint that will flow better than a straight oil paint; it gives a less porous film, and one more even in thickness.

For the first, or priming coat, we consider it good practice to apply a thin paint carrying a small quantity of very finely ground pigment so that it will penetrate as far as possible into the pores of the metal. The pigment may be oxide of iron and inert material. This coat should be applied immediately after the metal has been cleaned with the sandblast, before there is time for corrosion to form on the freshly cleaned metal, and it should be well brushed during its application.

The succeeding coats should have good body, a generous supply of pigment being used in the mixtures. We have found good oxide of iron paints suitable for these intermediate coats. The finishing coat must conform to the standards of the different railroads, but we consider a good

lamp or carbon black paint the most suitable, because it gives a non-porous film with excellent wearing properties. This should also be a combination linseed oil and varnish paint, with only enough volatile liquid to make the paint work properly. We have found it good practice to discard the use of body colors on the decks and deck screens and paint all parts one color, black, from body eave moulding on one side of the car to the body eave moulding on the opposite side. This simplifies the painting, especially at terminals.

To overcome the abrasion caused by cinders, also the troubles due to hot cinders falling on the steel roofs and burning out the life of the paint film, we find it good practice to sprinkle sand in the last coat of paint at the initial treatment.

It is now almost a universal practice to apply to the exterior body of new steel passenger equipment cars, from three to five coats of surfacer, two of color, and three of exterior finishing varnish, or a total of eight to ten coats, and our observations lead us to believe the bodies are pretty well protected. The roofs, decks, deck screens, etc., however, get only three or four coats as a rule, though the exposure is much more severe on these parts. From this it would seem that we may be applying more coats than is actually necessary for the protection of the steel on the bodies, and less than necessary on the roofs, decks, etc.

The maintenance of the roofs, decks, deck screens, etc., is



J. Gearhart, Vice-President,  
Master Painters' Association



A. P. Dane, Sec.-Treas.,  
Master Painters' Association



J. W. Gibbons, Vice-President,  
Master Painters' Association

fully as important as the initial treatment, for they should be maintained in such a manner that there is no chance for corrosion to get started. I hardly think it feasible to lay down hard and fast rules stating the exact time in which these parts should be repainted, for on the mountain divisions where there are numerous grades and tunnels, a few months' service may be more severe than a year's service in a prairie country where there are few grades, and no tunnels, or where oil is used as fuel in the locomotives. Again, some cars make considerably more mileage than others. In our opinion, watchful care is more essential than anything else to the preservation of these parts of the car. A paint with only moderate wearing properties, applied at the right time to prevent corrosion, will give better results than the best materials applied at irregular intervals, or after the parts have become corroded.

#### DISCUSSION

The New York Central has found it best to sand only the curved part of the roof. There is no need of sanding the level surfaces as cinders cut out only on the curved surfaces, sanding the level surfaces helping to carry moisture down to the surface of the steel. The experience of the Lackawanna has been similar. The Pullman Company is sanding its roofs all over, but it is believed that it is poor practice. Attention was called to the weather conditions under which steel is painted having effect on the service of the paint. Priming should not be done when the humidity is great. One member believed that metal should be painted only when it is at a temperature high enough to drive off all moisture. It was brought out that one road uses special pneumatic tools to clean the steel and has abandoned the sandblast. J. W. Gibbons of the Santa Fe stated that the quality of the steel is an important consideration. It must be free from impurities that are aggravated by moisture getting under the paint. It was decided by a vote that it was the consensus of opinion of the convention that it is detrimental to apply sand on the flat surfaces of a steel roof.

#### TREATMENT OF THE INTERIOR AND EXTERIOR OF TENDERS

A committee report on this subject was presented by W. A. Buchanan (D. L. & W.), chairman. It was stated that many roads do not paint the interior of tenders, but the report dealt more with general practice than with tenders alone, and it was the general opinion that for the exterior some method should be used to thoroughly clean the steel, the sandblast being considered preferable. A good coat of elastic primer should then be used, followed by the usual finishing coats, the process varying on different roads.

#### DISCUSSION

It was also stated that no paint will withstand the action of the water in tanks and particularly the action of treated water and that the painting of the inside of tanks was considered a waste of time and material. The Santa Fe uses treated water and it has been found that this forms a protective coating on the inside of the tanks, which is a better protective agent than any paint.

#### REMOVAL OF TRIMMINGS FROM PASSENGER CARS

J. W. FRYER (N. C. & St. L.).—There is no certain method for handling the work of removing trimmings, for the treatment that will prove satisfactory at one time, will not answer the next, although on the same car. For illustration, a private car was placed in the shop with orders that it must be finished the same day. The roof, platform, steps, and all outside iron work were to be painted, trucks and all glass cleaned, the outside of the body cleaned. In a case of this kind, it is not necessary that the trimmings should be removed, for time will not permit, and besides, there would be nothing gained.

Next, considering the same car for general painting, interior and exterior, in a case of this kind, all trimmings should be removed before the car is placed in the paint shop.

I am convinced that considerable trouble is caused by the trimmings not being removed at the proper time. If locks, hinges, sash and blind lifts, etc., are not removed, and properly cleaned, they will later mar the appearance of the car, and their removal will save some time and expense trying to keep varnish and paint off them.

#### DISCUSSION

The New York Central removes all interior trimmings in painting the insides of cars. E. L. Younger (Mo. Pac.), always insists on the removal of all sash. It was brought out that in washing the interior, care must be taken to prevent water getting through the holes used for screws, etc., after the parts are removed, as it will damage the inside surface of the steel, as well as the insulation. Most members believed that all sash should be removed in making repairs of whatever class and it was the general opinion that all interior trimmings should be removed.

#### TREATMENT OF LIGHT-COLORED HEADLININGS

F. W. BOWERS (Erie Railroad).—The Erie in former years had all wood and pulp headlinings of the first class, through line coaches painted white in flat colors, striped and ornamented in gold, then edged in black and two coats of transparent varnish applied. Afterwards, when dry, they were rubbed with pumice stone and water and polished with oil, leaving an eggshell gloss.

When coaches came in the paint shop at the next two or three shoppings the lining was scrubbed with the rest of the coach and then repolished with oil. In some cases, particularly the panels of the lining where the gas lamps are situated, which were colored by the heat of the lamps, we cut the ornamentations in with the former white flat color and finished as previously.

Since then conditions have changed and simpler and less expensive methods have been adopted. A great percentage of the former decorations are in part and in some cases wholly eliminated. While most railroads adhere to the varnish finish, some few have dispensed with it, applying paint in an enamel form or a color varnish instead, in order to eliminate varnishing and the striping and ornamentation.

I firmly believe that headlinings that are painted white or in light shades should be varnished.

THEO. HIMBURG (D. & R. G.).—I have experimented to some extent with building up new and repainting old headlinings over old paint, changing the colors from dark to light shades, also using flat color and enamel, and good results can be obtained with either flat color or varnish color. I always finish a varnish color or enameled surface with at least one coat of pale headlining varnish, while two coats of varnish are applied over flat color.

Several years ago I finished up one headlining with enamel and let it go without varnishing. The color was changed from a light green to a dark ivory by applying one coat of flat color, using plenty of varnish as a binder. After the usual method of puttying and sandpapering, a coat of semi-enamel was applied which dried with very little gloss. This was followed with a coat of varnish color which dried with a good gloss. Striping and ornamenting were omitted. This car was shopped again in 15 months, and after the headlining was washed I found that it would not pass with varnishing alone, but had to be repainted and varnished, ways necessary between shopping periods. I brought up several other headlinings in the same way, except that I finished them with one coat of varnish and from this method, good service was obtained, except that it did not have a very smooth finish.



Just recently it was necessary to place a new agasote headlining in one of our steel coaches. I washed this headlining with gasolene to remove the grease spots and primed it with a lead primer, the vehicle being one-third boiled linseed oil and two-thirds turpentine. This was puttied the following day and after the priming coat stood 48 hours, it was sanded and three coats of flat lead, sanded between coats and tinted to an ivory shade, were applied. The last coat was not entirely flat, the liquid being one-third rubbing varnish and two-thirds turpentine, in order to get a smoother surface for the striping and ornamenting. Then two coats of clear elastic varnish were applied.

In order to decrease the shopping period of each car shopped for paint, and in order to economize on account of the increased market price of paints and paint materials, we have resorted to the varnish color method, which is a cheaper way of doing work. When completed it also has the appearance of a cheaper job.

#### EFFECTS OF WATER AND OIL CLEANING METHODS ON PAINT

A paper was presented by W. A. Buchanan (D. L. & W.) on this subject, in which it was stated that the water which is used in this process should not be considered hot, as it is about 90 deg. and is not over 70 deg. when it strikes the surface. In two years' use at East Buffalo, no trouble has been experienced with painted surfaces due to heat, although there has been some due to wear. The process has greatly reduced the cost of cleaning locomotives and has given no trouble due to hot boxes or other causes of like nature. The interior of the cab is cleaned about every 15 days, and as the engines are always clean, it assists materially in keeping the men clean and facilitates inspection and repairs.

#### DISCUSSION

J. W. Gibbons of the Santa Fe believed that there was a film of oil left on the varnished surface and favored the use of dry waste on such surfaces or something that will not leave a coating that will catch dust and dirt. He believed the spraying method was entirely satisfactory for the running gear, but not for the jacket and other varnished surfaces. B. E. Miller of the Lackawanna stated that a film does form on the surface and while it is annoying and sometimes obscures the lettering, it is largely due to improper handling and the use of too much oil. It has lately been found practicable on the Lackawanna to occasionally wipe passenger engines with waste to remove this film. Several members considered the process injurious to varnish and paint, while others said that all the trouble lies in the improper installation and operation, they having had trouble at first, but the difficulties having been eliminated with the correction in the use of the machine. It was decided by a vote of the convention that the process was considered satisfactory for the running gear of the locomotive, but detrimental to the painted and varnished surfaces.

#### RAILWAY LEGISLATION AND ITS EFFECT ON BUSINESS

J. W. Gibbons, Atchison, Topeka & Santa Fe, presented a paper from which the following is taken: Many of the men who have advocated stringent regulation of the railroads are honest and have given expression to their conviction after careful consideration of the question, but a certain class of politicians who are ever ready to influence the minds of the people with the hope that they may ride into power on the wave of discontent they help to create, took advantage of the state of political unrest that prevails in our country, magnified the real grievances and multiplied the imaginary ones until some of the people thought the panacea of all their social and political ills was the confiscation or annihilation of the railroad companies.

The first to feel the disturbed condition of railroad business was the railway employee, then the retail merchant, whose customers could not meet their bills, next the wholesale house and finally the manufacturer and producer.

In spite of the increased mileage and the natural growth of the business of the country, 104,374 men were deprived of the positions that they had on the railroads in 1907. In spite of the great saving this appears to be on its face for the railroads, at the close of the year 1915 there were 20,143 miles of railroads in the hands of receivers, as against 317 at the close of year 1907, and yet, during this period of depression upon railroads, our country has been blessed with good crops, the foreign wars have created an unusual demand for the products of our farms, mines and factories, prices have soared and the expense of operation has increased.

The railroads have used up all their available material, their equipment and track has been worked to the limit and must be renewed if the business of the country is to be handled properly. The indirect loss to the country is immeasurable. Owing to the lack of funds to purchase equipment and build terminal facilities, many of our lines have become blockaded in the last six months, due to the rush of war munitions to the east. How many towns and counties in our country are lying dormant or going back because of the lack of confidence of men with capital in the future ability of the railroads to pay a reasonable return on the investment?

Let us hope that out of the chaos that has brought the railroads of our country to the verge of financial disaster, there will be an evolution that will place them on a firmer business basis and that the people will have a better and clearer appreciation of their work.

#### SHOPPING PASSENGER CARS FOR CLASSIFIED REPAIRS

H. A. POLHEMUS (Erie Railroad).—At present, equipment is placed in service after a general shopping and after each trip it is wiped off with dry waste, the waste sometimes being dipped into the oil box. This is bad practice. Continuing this practice for a year or more, rubbing the dirt into the surface dries out all the elastic qualities. It kills the finish and puts the equipment in condition for shopping much sooner than necessary. The proper practice at terminals to prolong the life of the finish is to use a good oil cleaner once in six months, rubbing the surface with a bead scrub brush or curled hair, removing all the dirt and wiping thoroughly with dry waste. This will keep the body in a more suitable condition for wiping with dry waste between the oil cleaning periods. If this practice was put in force and carried out to the letter, the shopping period would be more easily determined. Equipment taken care of in this manner would be less expensive to refinish and it would not need shopping under 18 to 24 months, providing a good grade of varnish was used to finish the body. Equipment kept in this condition would need an expert to determine the shopping period owing to the good condition of the finish.

The shopping of equipment should be done in a systematic way by an inspector, and a painter would be preferred, using his best judgment to get the bad cars through the shop first. At present, the transportation department sends the cars to the shop for general repairs, regardless of their condition. Very often cars get into the shop which should remain in service from six to twelve months longer and are stripped and scrubbed before the mistake is discovered. This is poor management and it could be avoided by employing a good inspector, with a saving of considerable expense to the company.

J. A. ALLEN (N. Y., N. H. & H.).—The master painter should have charge of the shopping of passenger cars. He has a complete record of the condition of the paint and varnish on all cars having gone through the paint shop at var-

ious times, and he is familiar with the application of paints and varnishes. He knows after the expiration of a certain time the condition of cars without even seeing them, owing to his familiarity with certain surfaces, colors and varnish used in his department, the quality of materials determining the length of service. He also knows that if he could call in



Fig. 1—Interior of Car No. 4579

cars at a certain period and were allowed to proceed on this plan, he could keep up his equipment with fewer men, less track capacity, and considerably less expense.

M. L. SHAFFER (Penna.).—The shopping of passenger equipment should be left to the master painter in charge, inasmuch as the classifying of the equipment is governed by the condition of the paint. He is the one who must be in



Fig. 2—Interior of Car No. 1717

constant touch with the situation, making periodical inspections, and is consequently familiar with the condition of the repairs previously given the car.

Instructions have often been given, to give a car light repairs, when it really required better attention, with nothing more in view than to place the car in service a few days in

advance of its allotted time. It might last only about six months, whereas had this work been left to the foreman painter and handled properly, the car could have remained in service from 14 to 18 months. Work of this character only reflects upon the ability of the master painter.

#### DISCUSSION

It was decided by a vote of the convention that it was the consensus of opinion of the members that the master painter should have charge of deciding what class of repairs is necessary for passenger cars.

#### THE PURCHASE OF PAINT ON RAILROAD SPECIFICATIONS

W. O. QUEST (P. & L. E.).—When a railroad asks a paint-making concern to put its lowest selling price on its own specified formulation for paint, it does so at its own risk, because in so ordering its paint supplies on an open market, the buyer assumes all of the responsibility for quality value. On the other hand, when the railroad buys the guaranteed specialty paint of the reputable railroad paint

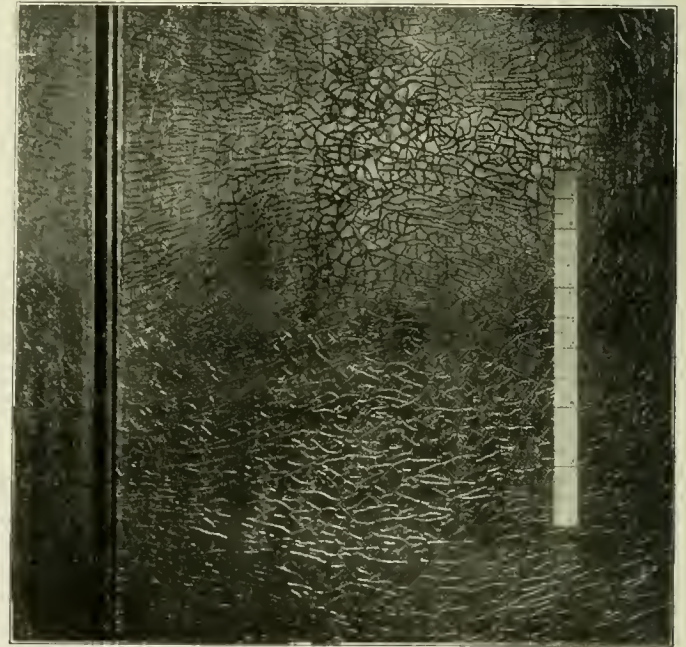

Fig. 3—Interior of Car No. 1621

maker at the usual, fair, established market value, there is no buyer's risk. The more I studied this subject, the more I became convinced that it is positive economy for a railroad to buy paint from the specialist maker. As a matter of business, the transaction is safer, because such reliable people have a business reputation to sustain, which, as a rule, they will back up.

There can no one doubt that the term "specification paint" is synonymous with the paint demands of the railroad paint shops that are operated in conjunction with well equipped chemical laboratories. It would then appear that the railroad without a chemical laboratory would be at the mercy of the frenzied competitive price cutting paint maker and seller, who is undoubtedly partially, if not wholly responsible for the unsatisfactory market condition that finally compels the railroad cheap paint buyer to resort to the science of chemistry for protection.

Regardless of the protection of chemistry, or the paint specification mandate, there is always trouble in the railway paint shop for which the foreman is not responsible. When paint, cheap in both price and quality, proves a failure, its maker as a rule will set up the complaint that he is the victim of a shop discrimination or that the shop in question

was either too hot, too cold or too damp to insure the safe application of his paint, which in a fair shop try-out often proves to be absolutely worthless. Now I do not wish to convey the idea that paint innovations should be barred from the railroad paint shop, but I do claim that all such new paint stock, regardless of formulas or specifications, should

tusing propaganda against paint specifications, a request came in for a quotation on a large order for paint oil. The railroad sales manager said: "Now what do you suppose is wanted? We can make paint oil covering a wide range of merit, composition and price. We do not know what this prospective customer wants to pay or how to deal with such inquiries." He could have said exactly the same thing with reference to a paint inquiry which was not accompanied by a specification. It would almost seem that the main object in trying to break down paint specifications, is to avoid competition.

It is argued by some that paint specifications retard progress, by fixing standards. Such argument has little weight,



Fig. 4—Exterior of Car No. 1775

be tested out for both its working and service wearing qualities so as to leave no doubt of final fitness.

There have been thousands of demonstrations that have taught the lesson that the best paint that can be bought is the cheapest in the long run. As a consequence, it does not matter whether the best paint is a reputable manufacturer's or a railroad specification paint, just so long as the purchasing company gets its money's worth. If the railroad specification paint is the best, let us have it, but not in its hazardous cheapest-in-price form.

DR. M. E. McDONNELL (Chemist, Penn. R. R.).—If chemists knew the best paint for each particular application, and if they could write a specification for each in such a manner that it could be complied with, and if all paint products not complying with the specifications could be rejected, there

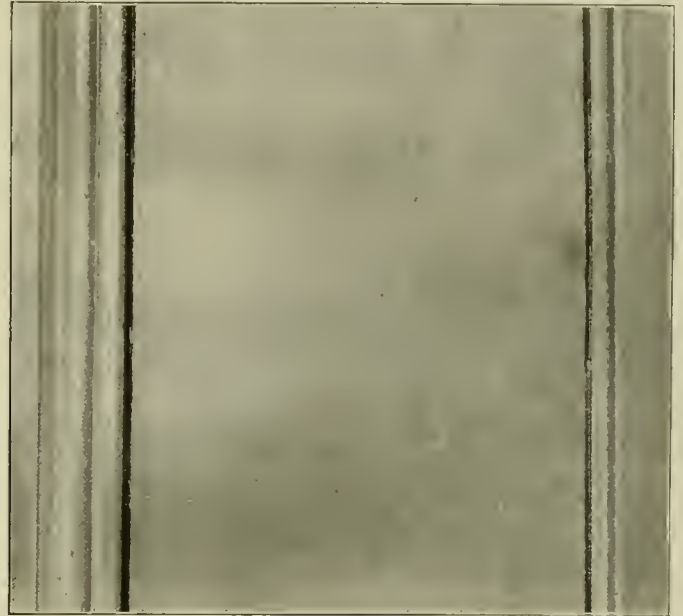

Fig. 6—Interior of Car Shown in Fig. 5

for any paint consumer would change his specification if he were convinced that it would be improved upon. This point is well illustrated by the history of the Pennsylvania Railroad specifications for exterior cabin car color. Prior to 1883 English vermilion was ordered for this purpose, and no tests were made to see what was being obtained, till the



Fig. 5—An Example of the Possibilities of Paint Durability

would be but one side to the question. A specification informs the purchasing agent and the manufacturers just what is wanted and affords a fair basis for competition, and there is no reason why any consumer should buy something which he does not want.

On the occasion of a recent visit to the factory of a large paint company, which has apparently organized an adver-

condition of the cars led Dr. Dudley to investigate and he found that in many cases no sulphide of mercury was present in many of the shipments. Furthermore, he learned that there was not enough English vermilion on the market to render it commercially available in the quantities desired. He accordingly issued a specification for scarlet lead chromate and tested all shipments to see that they did comply

with the standard designated. After the specification had been in force for a number of years, there was a development in the state of the art of the manufacture of certain organic pigments, some of which had great merit, and in 1911 the company again changed the specification, this time to toluidine red, a product of unquestioned merit. In 1915, war conditions made it necessary to again change, and at this time the use of an iron oxide composition was adopted. The specifications have consistently followed the progress of development, and will continue to do so, but during all of this time, all manufacturers have had a definite basis on which to work.

One of the early paint specifications issued by the Pennsylvania Railroad was for freight car paint, this having now been in force since July 26, 1886. On looking over a recent catalogue of a prominent dry color manufacturer, we read as follows:

"Pennsylvania Freight Car Red.—We wish to call the attention of paint grinders to the great covering capacity of this red, it being far superior to some of the reds made up of combinations of various pigments, by some of the paint manufacturers. It is less liable to settle, and works out with that fine consistency so desirable in a paint."

To read such a statement after a 30-year trial is certainly gratifying, and it is well known that a number of prominent paint manufacturers comply with this specification in their standard trade iron oxide paint; furthermore, it is approved by the Russian Government in their contracts.

It would not be fair to assert that all of the criticism against paint specifications is unjust. In drawing up a specification, it is important to first ascertain by experience what will meet the practical requirements of service. The composition called for should not be unnecessarily restricted. It must be a product readily available. It is also important that the purchaser can make the necessary tests, to compel compliance with the specification. To state what is desired without insisting on compliance with the requirements, is unfair to competing manufacturers, and does not protect the consumer. There is a tendency in certain quarters to write specifications which cannot be enforced. The fact that some specifications are written without due consideration does not condemn a sound principle. It would be just as fair to condemn the practice of medicine because some quack doctor without any knowledge of medicine is allowed to practice.

It is not practicable with our present knowledge to control the purchase of all paint produced on chemical tests. In such cases, physical tests can be devised, which we believe will be fair to competing manufacturers, and at the same time protect the consumer. Varnish is a good example of a product which, in our opinion, cannot now be controlled chemically, yet we believe it is possible to devise a specification under which it can be purchased on a competitive basis. The accompanying illustrations show the necessity for such tests. Fig. 1 shows the interior of a 54-ft. compartment car, No. 4579, completed May 29, 1912, which received class repairs including color on the exterior and varnish throughout which were completed on May 21, 1913. It was photographed February 7, 1915. The car had been in service 1 year, 8 months and 17 days, following class repairs.

Fig. 2 shows the interior condition of a 70-ft. passenger car, No. 1717, completed by another car builder September 1, 1908, which received class repairs, including color and varnish on exterior and interior, which were completed on February 11, 1910. It was photographed about December 1, 1911, after 1 year, 9 months and approximately 20 days service, following class repairs.

Fig. 3 shows the interior condition of a 70-ft. passenger car, No. 1621, which was new January 20, 1910, and was photographed on or about December 1, 1911, after 1 year, 10 months and approximately 20 days service and before it had received any class repairs.

Fig. 4 shows the exterior condition of a 70-ft. passenger car, No. 1775, which was new in January, 1909, received class repairs, including exterior color and varnish which were completed on April 13, 1910. It was photographed on or about December 1, 1911, after 1 year and approximately  $7\frac{1}{2}$  months service, following class repairs.

The appearance of these cars is far from satisfactory. Ignoring class repairs, one of these cars had been in service less than two years, two were less than three years old, and the fourth car, which was the oldest, had been built only three years and three months.

Fig. 5 shows what is possible in the way of durability. This car was completed in January, 1913, and photographed 3 years, 4 months and 14 days later, before it had received any class repairs. Fig. 6 shows the interior condition of the same car. With such examples confronting our officers, it was considered necessary to more rigidly control the purchase of varnish. It is but fair to state that this car, No. 156, was painted by the baking process. The varnish was one of four selected from panel tests of a large number of



Fig. 7—Method of Exposing Test Samples on the Pennsylvania

baking varnishes. The preliminary tests on varnishes of this class had been elaborate and showed that many of the samples submitted by manufacturers were inapplicable. The result of these trials on baking varnish were so convincing that it was decided to have the same tests applied to other kinds of varnish. A method was accordingly worked out and put in effect January 1, 1915, which we believe gives protection, and while varnishes are now virtually bought on specification, we are confident that the manufacturer is not limited in the exercise of his ingenuity. The fact that a test was started on some 50 brands of varnish this month shows that the method does not prevent competition.

The method is largely practical, the tests being made on standard sandblasted steel panels made from sheet steel which was purchased for the construction of passenger cars. Each panel is 14 in. by 30 in. in size. One side of a large number of such panels is prepared by applying a suitable

surfacing system and two coats of flat Tuscan red, excepting a space 3 in. by 30 in. at one edge which is left bare. Each panel is then laid off into six sections, and each section is numbered consecutively, the figures being white, and a white stripe is applied lengthwise across the panel over the Tuscan red. The object of the white stripe is to make possible a better judgment of the color of the varnishes under test, dark varnish being objectionable. A number of such panels, estimated to be a year's requirement, are prepared at the same time and kept in stock till they are required. The varnish samples to be tested are divided into groups, made up of the various classes which are used. It is desirable to have six samples of the same kind of varnish. In every case, a standard sample should be included, as the results obtained will vary more or less according to weather conditions, the test being comparative. Three coats of each sample are applied to the assigned test panel section, at intervals of 48 hours. After the third coat has stood for 48 hours a portion of each section is rubbed, excepting finishing varnish. Rubbed sections are observed for a period of 24 hours for "sweating out" defects. It might be said that throughout the application of the sample being tested, notes are made of any defects in color, drying properties, flow, etc. On the third day following the application of the last coat of varnish, all test panels are placed in a vertical position on a rack having a southeastern exposure, and observations for checking are made at intervals of two or three days. As previously stated, it is imperative that each class of varnish under test be accompanied by a standard sample, as the time of checking will depend somewhat on weather conditions, but if this precaution is taken, the relative time of checking shown by the different brands of varnish is a fair measure of their relative durability.

In the purchase of varnish, it is our practice to place requisitions for any of the brands which are on an approved list. Samples from all shipments received are tested, and if the quality is found to be below "standard" such brands are dropped from the approved list and purchase of them discontinued. New brands of varnish are also added to the approved list from time to time, after the test as outlined has shown them to be entitled to this recognition. Fig. 7 shows a portion of the test rack as it existed on September 1.

We believe it is possible to formulate and apply specifications for the various classes of paint products, including varnish, which will be a stimulus to greater effort on the part of the manufacturers, and which will reward them for creditable efforts. The consumer will also reap the benefit of such improvement, and the painter will feel better satisfied with his work, especially if he has the opportunity of seeing it after it has rendered several years' service.

#### PAINTING OR OILING THE INTERIOR OF STEEL HOPPER CARS

J. GRATTON (B. R. & P.).—Corrosion starts principally from the interior of the car, eating its way through the floor, hopper and side sheets, making necessary the shopping of the car to renew the sheets. On account of the present high cost of labor and material this is a very expensive operation. Furthermore the loss of revenue resulting from withdrawing the cars from service when so badly needed is large.

On the Buffalo, Rochester & Pittsburgh, to determine the benefits which would be derived from coating the interior of the cars with oil, we arranged some time ago when cars were shopped for exterior painting or were undergoing heavy repairs, to thoroughly clean and remove all scale and rust from the interior of the car by the use of the hammer and by blowing out with a compressed air jet. The sheets were then given a coat of oil with a paint spraying machine. The cars, after being put back in service, were periodically examined and we found that the oil evaporated very quickly, resulting in very little permanent benefit. At present we are

experimenting with more cars, applying a coat of elastic paint with the spraying machine. We find the machine to give better results than can be had applying the paint by hand with a brush, as the corners and crevices around the rivet heads are better filled and all openings at the seams are penetrated by the paint spray. We find this practice to have some advantage and as long as the paint or oil lasts it retards the wasting away of the sheets. When we examine the cars which we have oiled or painted, after they have been loaded, we find that much of the paint has been rubbed off in service by the loading and discharging of the lading. However, the principal wear is on the broad faces of the sheets and if the cars are kept constantly in service this wearing has a polishing or scouring effect which helps to offset corrosion. If we direct our attention to the seams, corners, etc., and around the rivet heads, which are the vital points, we find that the same scouring effect is not noticeable, and that unless the coating has well protected the parts there will be a mass of rust and scale which constantly and slowly will destroy the steel, whether the car is in service or not, greatly weakening the structure and diminishing the life of the car.

#### DISCUSSION

In reply to a question by J. W. Gibbons of the Santa Fe, the author stated that the oil used is a Pennsylvania oil with a paraffine base. Mr. Gibbons stated that he believed it would be desirable to have tests made, using an oil which had an asphalt base. The cost for labor in doing this work on the Buffalo, Rochester & Pittsburgh is 28 cents per car. A committee was appointed to continue investigations on this subject. W. O. Quest (P. & L. E.) said that paint is of no use for the protection of the insides of steel freight cars, as it either burns or wears off. The Norfolk & Western has applied oil with a spray for protective purposes, and has lately changed to painting, using one coat of red lead and one of carbon black.

#### VARNISH REMOVER FOR REMOVING PAINT

GEORGE H. HAMMOND (Soo Line).—Varnish remover, as it is now made, is a marvel of efficiency as compared with the product of a few years ago. It was then a crude, pungent, slow acting and expensive material. It was a menace to the health of those who used it in confined places. Many master painters were prejudiced against it, believing it would cause trouble to the coats applied over surfaces where it had been used.

The manufacturers of such removers have been constantly striving to perfect their product and have succeeded so well that little fault can be found with the present day product, and it is considered an absolute necessity in every paint shop. Removers which soften varnish and paint rapidly, but evaporate slowly and do not separate or settle, are found to be the most economical and efficient. With the use of proper appliances, such as spray machines, vacuum machines and specially constructed brushes, both hand and power, maximum efficiency is obtained. Thus equipped, and with skillful labor, the paint on the wall surfaces of the interior of a steel passenger car can be removed at a cost of 50 cents per foot of car length, 60 per cent of this being expended for labor and 40 per cent for material.

Taking the outside of a steel passenger car into consideration, we find that the cost to remove the paint with varnish remover is practically the same as the inside. The ratio of expense for labor and material is different, as it requires less labor but more material; 45 per cent goes for labor and 55 per cent for material. This estimate applies to steel plate construction with the rivets exposed.

In shops where the necessary facilities are installed, a quicker and less expensive way to remove the paint from the outside of a steel passenger car is by sandblasting. The cost is 7½ cents per foot of car length for labor. Sand, air

and wear on sanding equipment, will be approximately  $2\frac{1}{2}$  cents, making in all 10 cents per foot of car length, or \$8 for an 80 ft. car, a saving of 80 per cent of the cost of removing with varnish remover. These figures will, of course, vary.

It is not practicable to use the sandblast on the interior surface of a steel passenger car, owing to the confined space, great accumulation of dust and inability to blast such parts as need it without damaging parts which do not need it. Also, the steel itself is so thin that there is danger of buckling or even cutting through weak places. Neither should the outside of a steel passenger car constructed in imitation of wood sheathing be sandblasted; the steel is too thin to stand it, but the thick plate construction will stand many sandblastings.

#### DISCUSSION

The Santa Fe has successfully used the sandblast method for cleaning cars with the finish made in imitation of wood. The cost is 7.1 mills per square foot and as this is a beaded surface, this cost is probably a little more than would be necessary on a smooth surface. O. P. Wilkins (N. & W.) doubted if the sandblasting described by Mr. Gibbons could be carried out many times, as it would wear out the metal. In reply Mr. Gibbons stated that this has been considered, but the amount of metal removed is so small, that the car can be sandblasted probably four times without injury. It was decided by a vote that it was the consensus of opinion of the meeting that there is nothing superior to varnish remover for use on the inside and sandblasting for use on the outside of steel cars for removing paint.

#### USE OF SOAP IN CLEANING PASSENGER CARS PREPARATORY TO VARNISHING

W. MULLENDORF (Ill. Cent.)—Both soap and water vary in quality for this purpose. "Hard" water will deposit lime by contact with soap and make a lime-soap combination, very irritating and destructive to varnish. Soap, in commercial form, carries a caustic or potash base, both of which are the natural enemies of paint and varnish and are active solvents of them. Soaps will have the same effect as lye in a modified form. To be more effective than plain water, soaps must be powerful enough and used in sufficient quantity to precipitate the limes in water in order to produce softening, leaving a surplus of alkali strength to decompose the various dirt deposits on the surface of the car. The alkali deposits left from wash water lead to spotting and changing of color.

Practically the same action takes place from the use of soap in "soft" water. So-called neutral soaps that show no free alkali are rare and entirely too expensive for car cleaning so that the field of soap and water cleaning is limited to those soaps that generally affect the skin of the operator and in like manner the skin of the varnish or paint.

The action of soap and water cleaning is particularly noticeable on paint, which it gradually washes away. Varnish is more resistant to this action of soap and water because of being harder, but its gloss is reduced with each washing and checking follows rapidly, depending on the strength of the alkali.

The absorption of oils from either paint or varnish is known as weathering, and is done by the atmosphere or alkalies, or both, and leads to cracking or checking of the surfaces. Alkalies accelerate this destructive action by lodging in the multiplicity of checks. It will be seen that thorough rinsing after the use of soaps is highly important.

In the washing of cars it is important to feed the varnish or paint, and not gradually extract the life of these coatings, as is done by the use of soap, caustic potash, sodas or other alkalies, all of which are deadeners to the finish. A car cleaner, to be economical, must therefore be harmless to

paint or varnish and free from alkali, otherwise its repeated use will hasten the car to the paint shop and make it unattractive in the meantime.

The best car cleaning compounds are based on varnish-feeder, non-alkali, non-injurious lines. Those most in use are based on gums made up in the form of emulsion. These cleaners are applied with a large hand brush and owing to their consistency, remain on vertical surfaces without running off. A few minutes time is allowed for soaking the dirt, after which the surfaces are scrubbed with ordinary scrub brushes and rinsed off with water. Wiping with chamois skin brings out the polish, although this is not necessary. After this treatment, varnished or painted surfaces dry without the streaks common to soap cleaning. Surfaces thus cleaned have no tendency to collect dust.

From the fact that surfaces of cars are often not well rinsed after scrubbing, the nature of the cleaner used is highly important. Soap has a blooming and dulling effect upon varnish. The residue left on surfaces from alkali absorbs moisture from the atmosphere, and moisture collects dust, making more frequent cleaning necessary and incidentally more painting and varnishing. A standard gum cleaner enters the numberless pores and checks of the varnish and acts more or less permanently as a filler or "feeder."

The general use of pumice in connection with soap and water for car cleaning acknowledges the inefficiency of soap. Pumice becomes the main cleaning factor and is efficient for the purpose, but destroys gloss and removes a thin skin of the finish with each application. It is also difficult to remove by rinsing and usually leaves the finish with a grey effect out of harmony with the color scheme of the car.

#### DISCUSSION

The New York Central uses for cleaning cars preparatory to varnishing a solution of muriatic acid, followed by a weak soap solution and pumice preparatory to painting. This does a very thorough job with a decrease in the labor necessary. The strength of the acid is varied according to the condition of the cars and is never less than three parts of water. For general use, nine parts of water to one part of acid was recommended. The Denver & Rio Grande washes all cars every 60 days with oxalic acid and renovates them. On the Santa Fe it is considered that if the soap used is good and is properly handled, it will give satisfactory results. It was also brought out that the success obtained with acid cleaners depends largely on the manner in which they are mixed and used.

#### OTHER BUSINESS

F. W. Brazier, superintendent of rolling stock, New York Central, addressed the association and made a number of encouraging remarks intended particularly for the younger men, not only the painters, but employees of the car department as a whole. He referred to the fact that the car department is recognized as it should be on but few roads and that its men should be just as eligible to promotion as men who are engaged in locomotive work.

Chicago received the greatest number of votes for the next place of meeting. The following officers were elected for the ensuing year: President, John Gearhart, Pennsylvania Railroad; first vice-president, J. W. Gibbons, Atchison, Topeka & Santa Fe; second vice-president, E. L. Younger, Missouri Pacific; secretary-treasurer, A. P. Dane, Boston & Maine.

ADVANTAGES OF HIGH-VELOCITY STEAM PIPING.—The advantages of small, high-velocity steam piping are: Lower first cost for pipe, valves and covering, etc.; less erecting and maintenance cost; less weight; less radiation loss; less chance for water to accumulate; and less difficulty with valves of smaller size.—*Power.*



# Shop Practice



## INJECTOR STEAM PIPE ROLLER AND EXPANDER

BY R. J. HETTENBAUGH  
Apprentice Instructor, Big Four, Mt. Carmel, Ill.

The illustration shows a small hand tool in the form of a roller for the new type of injector steam pipe joint which is being quite generally adopted. The non-brazed joint is

## UNION PACIFIC EXTENSION EXHAUST PIPE SEATS

The usual method of securing exhaust pipes to a seat on the cylinder by means of studs and tee-bolts is a very difficult joint to maintain when the exhaust pipe loosens and leaks at the seat. To provide a better fastening and make repairs to the joint easier on account of a more accessible

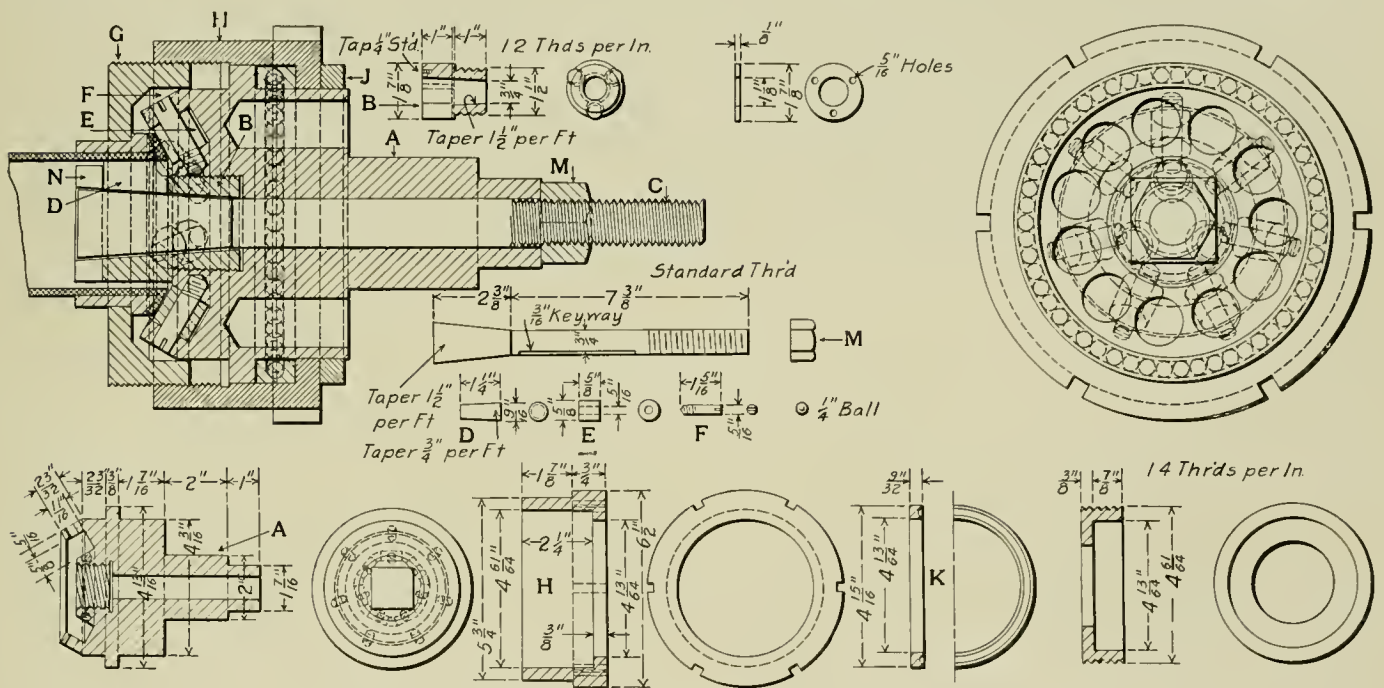

Section and Details of Tool for Forming Injector Steam Pipe Joints

shown in the cross section of the tool and consists of a brass collar over which the copper pipe is bent and rolled down to form the joint.

The joint is formed in the tool by tightening the spanner nut *H* on the split collar *G*, which presses the rollers *E* against the copper. The body *A* then revolves on the ball race *K* which lies between the collar on the body and the nut *H*. The nut is held in place by the small collar *J*. The taper pin *C* revolves with the body *A* through a keyway. By drawing up on the nut *M* the rollers *D* are expanded against the inner periphery of the copper pipe and prevent it from being forced away from the sleeve.

The tool can be operated either by hand or by attaching an air motor, as desired. It weighs 20 lb. and can be made at a very low cost. It has been in operation at the Big Four shops at Mt. Carmel for several months and is giving very satisfactory service.

**WEIGHT OF CONDENSING WATER.**—In condensing steam it is customary to use about 27 to 30 times as much injection water (by weight) as the steam to be condensed; the temperature of the hot water should not be above 120 deg.—*Power.*

location, the extension seat and flange shown on these drawings was designed and has been placed in service on several engines on the Union Pacific.

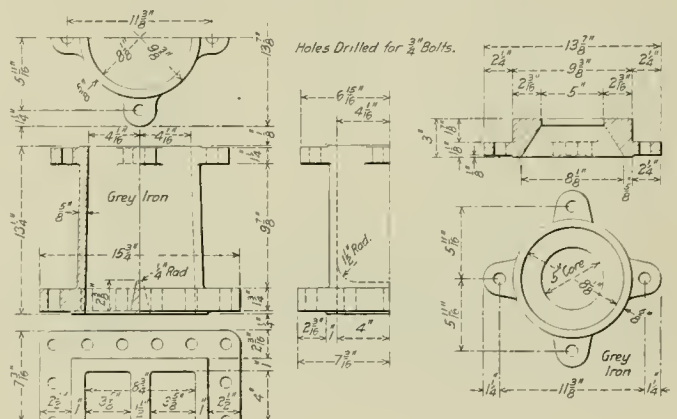

Exhaust Pipe Used with the Extension Seat

This consists of an extension of the cylinder exhaust passages to a point  $11\frac{3}{4}$  in. above the smokebox flange, thus





# THE GENERAL FOREMEN'S CONVENTION

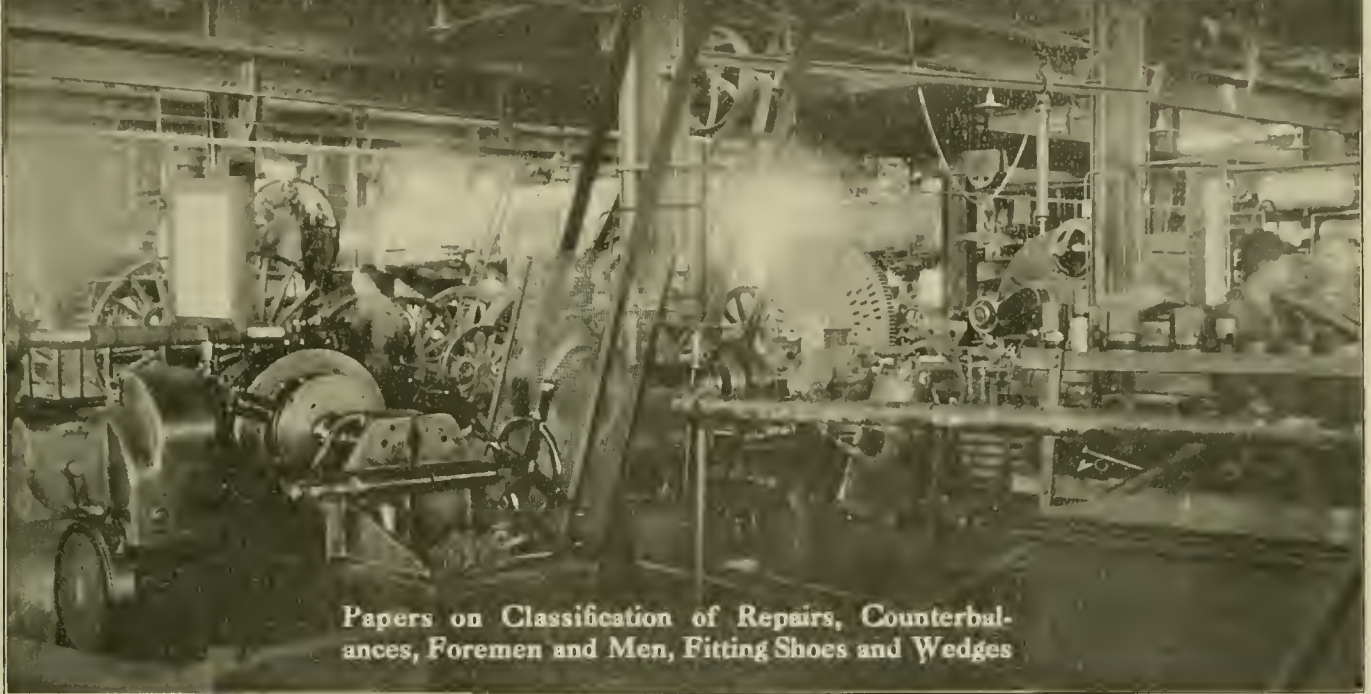

Papers on Classification of Repairs, Counterbalances, Foremen and Men, Fitting Shoes and Wedges

THE twelfth annual convention of the International Railway General Foremen's Association was called to order by the president, L. A. North, on Tuesday morning, August 29, 1916 at Hotel Sherman, Chicago. After prayer by Doctor Frank W. Gunsaulus the association was welcomed to the city by Daniel Webster, the response of the association being made by W. W. Scott. President North then delivered his address. He said in part as follows:

This association was formed for educational purposes and in the selection of subjects this point has not been lost sight of. We realize that it is only by the careful study and the expressions of the members that the points are brought out which are of value in the handling of men and materials. It is also well to keep before the members of the association the idea that their advancement and promotion depends upon their ability to look ahead and prepare for the future. As general foremen, you are leaders; the examples you set will largely govern the actions of your subordinates. By using tact and good judgment you can secure their confidence and loyalty.

After a brief address by Dr. Angus Sinclair in which he spoke of the important part which the influences surrounding the apprentice have in his success in after life, the secretary-treasurer presented his report. The association has a total membership of 229, of which 200 are active members; and there is a balance in the treasury of \$86. Secretary Hall called attention to the growing influence of the association, and as proof of this stated that requests have been received for copies of the proceedings from Tokio, Japan; Bolivia; Peru; Manchester, England, and from South Africa.

On Wednesday morning the association was addressed by Frank McManamy, chief boiler inspector of the Interstate Commerce Commission. The following is an abstract of Mr. McManamy's remarks:

## MR. McMANAMY'S ADDRESS

The purpose of the regulations or inspection rules which were established as provided by the locomotive inspection law

of March 4, 1915, is to more definitely show when a locomotive is "in proper condition and safe to operate" as required by Section 2, and to guide the railroad company and its employees and the federal inspectors so their compliance with and enforcement of the law may be along uniform lines. Broadly speaking, the law requires locomotives to be maintained in "proper condition and safe to operate" and provides for an organization to see that it is complied with. The rules are more specific and definitely fix the responsibility for the performance of certain tests, inspections and repairs required by them. I shall not attempt to explain or define each rule, but will try to make clear those that are somewhat general in their terms and with respect to which numerous questions have been asked.

Rule 2 is identical with rule 7 of the boiler inspection rules. It definitely fixes the responsibility for failure to make inspections as required by the rules and requires the mechanical officer in charge at each point to know that inspections and repairs are made in accordance with the rules.

The general purpose of rule 4 is to require the present practice of inspecting locomotives daily to be continued and to avoid, if possible, the necessity of requiring additional sworn reports of inspection. Form 2, which is required by rule 4, was intended to accomplish two definite purposes: first, to insure an inspection of each locomotive at certain prescribed periods; and, second, to require the foreman or officer in charge to know the condition of the locomotive, and to say why defects reported were not repaired before the locomotive is returned to service.

This rule will assist in definitely fixing the responsibility for operating defective locomotives. It will also require the foreman to exercise more careful supervision over the work, so that he may properly sign the report. These inspection reports must be filed in the office of the railroad company where they can be checked if necessary.

I have no doubt that many of you feel that these rules have placed additional burdens upon the foreman, but such was not the intention and a proper observance of them will

result in just the opposite. They will require each man to shoulder the responsibility that rightfully belongs to him.

If the foreman uses the report as was intended and makes it show the exact reason why repairs were not always made, the responsibility will be placed exactly where it belongs. If proper material is not provided, or if the appropriation is exhausted, or if the transportation department refuses to let him hold the locomotive, that fact should be noted on the report so that it may be considered in determining the reason why the repairs were not made. If the foreman attempts to cover up all such conditions by showing repairs made, which, in fact, were not made, he will be shouldering a burden that he will soon find himself unable to carry.

The locomotive inspection law has not been in force long enough to show any material results. In fact, during the first year or two that any such law is in force the principal thing that can be accomplished is to investigate accidents and classify the causes so that we may determine just what remedies to apply. Enough data have already been obtained, however, to justify a word of warning and advice with respect to the inspection and repair of certain parts where in the interest of safety former practices should be improved. Draw gear between the locomotive and tender, including safety chains or bars with their fastenings, should be frequently and carefully inspected, 22 accidents resulting in 2 killed and 21 injured having already been reported due to failure of the draw gear.

Reversing gear has caused 38 accidents, most of which could have been prevented by proper inspection and repair and by providing sufficient clearance around the reverse lever to prevent injury when handling it.

Failures of rods and crank pins have caused 23 accidents, resulting in 1 killed and 25 injured. There is no doubt that a better method of inspecting these parts can and should be followed, although it must be admitted that the defects which cause failures are usually of a character which are difficult to detect. However, better maintenance of rods and boxes will do much to prevent such defects from developing and thereby aid in preventing accidents.

Failure of springs and spring rigging, which is frequently said to be of little importance from a safety standpoint, has killed 2 and injured 7 since such accidents have been reported to us. These parts should be given more attention and in no instance should a washout plug with a projecting square head be used where it can be struck by springs or equalizers in case of failure. Many similar matters might be enumerated, but enough has been said to direct attention to the causes of some of the most frequent and serious accidents and to give a general idea of the purpose and scope of the work of the Locomotive Inspection Bureau.

#### CAR DEPARTMENT PROBLEMS

An abstract of the paper on this subject was published in the September issue of the *Railway Mechanical Engineer* on page 453.

#### DISCUSSION

The paper and the discussion all indicate a growing appreciation on the part of locomotive department foremen of

the importance of the car department. As the general foreman of the locomotive department is usually in line for promotion to the position of master mechanic he should endeavor to become familiar with car department matters by keeping in touch with the car foreman. The work of the car department not only involves the actual mechanical work of repairing cars, but also requires a knowledge of the Master Car Builder's rules, the safety appliance standards, rules for loading material, etc., concerning all of which the general foreman should acquire some knowledge.

It was brought out that the work of the car department in expediting the movement of cars may often be greatly facilitated by the locomotive department. The majority of car repair shops or repair yards are not very well equipped and must depend upon the locomotive department for much of their blacksmith and machine shop work. While it is natural for the general foreman to be more interested in the output of his own department he should not overlook the fact that lack of proper co-operation with the car department often results in delays of from eight to ten hours to cars under lading, because the work required by the car department was not given the attention it deserves. The opinion was expressed that sufficient interest has not been taken in the subject of car department apprentices. An apprenticeship system is needed to develop the right kind of material for foremen in this department.

Several suggestions were made for the prevention of hot boxes. A case was mentioned in which considerable trouble from hot boxes was found to be due to the practice of the car repairmen of putting new wheels in service without scraping the paint off the journals. It was thus impossible to detect slight burrs or rough spots which might be on the journals, before they were placed in service. By scraping off the paint and inspecting the journal it is possible to smooth up any rough spots which may be found, with a file and emery cloth, this practice having resulted in a decided reduction in the number of hot boxes. The importance of rolling the surfaces of the journals after they are fitted was emphasized. Where this practice is not followed the surface of the journal will be smooth in one direction, but slightly rough in the other. If it is known in which direction a car to which the new pair of wheels is applied, is going to run on its next movement the probability of hot boxes can be greatly reduced by placing the wheels under the car so that the journals will run in the smooth direction.



L. A. North, President,  
General Foremen's Association

#### LOCOMOTIVE COUNTERBALANCES

BY H. E. WARNER

Superintendent of Shops, New York Central West, Elkhart, Ind.

There are two forms of driving wheel counterbalance in general use—the style commonly used on wheels of large diameter, where it is possible to obtain sufficient weight far enough from the center of the wheel to obtain the required balancing effect, is the one cast solid with the wheel centers. On wheels of small diameter, where it is impossible to obtain enough weight in the required space, the counterweights are cored hollow and then filled with lead. It is the practice in some of the large shops to pour the lead

into open chambers, which are covered with a steel plate bolted on, or the core holes are tapped and plugged. This prevents any possibility of the lead being lost out or shaken loose and rattling around as the wheels revolve, which might occur in the case of improperly cleaned and filled closed chambers.

This weight in the wheels must balance all the revolving parts, and a portion of the reciprocating parts. The greater the proportion of reciprocating parts that are balanced, the smaller will be the longitudinal disturbance of the engine, but the greater will be the vertical disturbance. This unbalanced vertical component causes the pressure of the driver on the rail to vary during its revolution, and if the engine is running at high speed like the blow of a heavy hammer. On the other hand, if too little of the reciprocating parts are counterbalanced there will be an excessive longitudinal disturbance of the engine.



W. T. Gale, Vice-Pres.,  
General Foremen's Association

The counterbalance should be a medium between these two extremes, and the only question is: What portion of the reciprocating parts is to be left unbalanced?

A great many experiments and theoretical calculations have been made to find an answer to this question. Dr. W. F. M. Goss, one of the early investigators of the action of overbalance on the rail, presented a paper before the meeting of the American Society of Mechanical Engineers in New

York, December, 1896, in which experiments in the Purdue Locomotive Testing Laboratory were summarized. The rear driver of the locomotive (a 4-4-0 type) was overbalanced about 50 per cent according to various rules. At speeds in the neighborhood of 60 m.p.h. the greatest pressure of the wheel on the rail was 28,000 lb., or twice the static pressure. It was also shown that the contact of wheel and rail is not continuous, but a succession of impacts. This was shown to be



C. L. Dickert, Vice-Pres.,  
General Foremen's Association

true even when wheel pressure is heavy.

The rule adopted by the American Railway Master Mechanics' Association is to balance the weight of all the reciprocating parts on one side of the engine minus 1/400 part of the weight of the engine. This rule is generally used throughout the United States. It is modified, however, in some instances by limiting the counterweights to from 55 per cent as a minimum to 65 per cent as a maximum of the weights of the reciprocating parts, for road engines, this weight being divided equally among all the

driving wheels. This is not universal practice. If the wheel centers are too small to put all the counterbalance apportioned to the main drivers on the side opposite the crank pin, and get it within a reasonable area that does not exceed the area of half of the semi-circle, the excessive weight should be distributed equally among the remaining wheels on the same side of the engine.

On the Chicago & North Western the practice is to make the final adjustment of weight in the counterbalance after the axle and crank pins have been pressed in. The wheels, with crank pins, nuts and washers in place, are so arranged that the journals can roll on level straight edges. On main wheels of outside hung valve gear engines both eccentric cranks must be in place. On the side opposite to the one being weighed a weight equal to the weight of the back end of the eccentric rod must be hung on the eccentric crank pin; the crank pin on the opposite side from the one being weighted should be above and in a vertical line drawn through the center of the axle. Weights are hung on the crank pin until the wheels are balanced, and will remain in any position. The sum of these weights should equal the required unbalanced weight, which is composed of that portion of the main rod and side rod plus the reciprocating weight, which belongs to the wheels being balanced. If the sum of the weights does not equal the required unbalanced weight at

the crank pin, then additional weight must be added to, or, as the case might be, weight should be removed from the counterbalance until the wheel does balance.

All the revolving weights belonging to each wheel and all the reciprocating weights on one side, less the total weight of engine divided by 400, are balanced. This weight is to be equally divided between all the wheels on one side. The revolving weights are the crank pins complete with nuts



W. F. Hall, Sec.-Treas.,  
General Foremen's Association

and collars, the back end of the main rod complete, and that portion of the complete side rod which belongs to each wheel. On the outside hung valve gear engines, in addition to the above, the eccentric crank complete, and the back end of the eccentric rod complete, are included. The reciprocating weights are the piston and rod, crosshead and pins, crosshead arm, the lower end of the combination lever arm, the combination lever link, and the front end of the main rod, all parts complete. The side rods and main rods should be weighed complete with each bearing separately supported on round bars passing through the center of the bearing.

The practice of the New York Central corresponds to the rule adopted by the American Railway Master Mechanics' Association, except that the weight of the reciprocating parts minus 1/400 weight of engine is changed when necessary to come inside the following limits: For wheel centers under 58 in. in diameter the minimum is 55 per cent, and the maximum is 66 per cent of the total reciprocating parts. For wheel centers over 58 in. in diameter the minimum is 60 per cent, and the maximum is 66 per cent of this weight. The reciprocating parts taken into consideration are: the piston complete, the piston rod, the crosshead complete, the crosshead arm and the combination link on Walschaert

valve gear engines and the front end of the main rod complete. The main and side rods are all weighed on knife edge supports. The allowance for the weight of the eccentric crank is 40 lb. for cranks the weight of which is less than 50 lb. and 80 lb. for cranks the weight of which is 50 lb. or more.

The final adjustment of the counterbalance is made as shown in Fig. 1. The axle supports are  $1\frac{1}{2}$  in. by 10 in. by 50 in. steel plates mounted with horizontal adjustment on cast iron horses. The weight support is of wrought iron hung from a yoke to fit over the crank pin, the bearing being on two 3-in. rollers set 4 in. between centers. The axle supports are leveled with a spirit level. The counterbalance is adjusted to make the opposite pin set exactly over the center of the axle.

A report on "Counterbalancing" presented to the Master Mechanics' convention, June, 1915, advocated a ratio of



Fig. 1—Adjusting Counterbalance on a Locomotive

the total weight of the reciprocating parts on one side of the engine to total weight of engine. Tests were run on nine engines of the 4-4-2 type, 80-in. drivers, on the Philadelphia & Reading to determine what this ratio should be. At the conclusion of the test the recommendation was made that the reciprocating parts should weigh less than 1/160 part of total weight of the engine, and that 50 per cent should be counterbalanced for engines running at "diameter speed," i. e., a speed in miles per hour equal to diameter of wheels in inches. If normal speed is less than this, the counterbalance percentage may be raised to as high as 65 per cent.

It is very evident that the percentage of the reciprocating parts balanced is simply a compromise to give the

best average performance at all speeds within range of the locomotive. But, on the other hand, the amount of counterbalance apportioned to the reciprocating parts should be kept as low as possible in order to minimize the so-called "hammer blow" on the rail, and to make the motion of the engine more steady. The logical solution then is to keep the weight of the reciprocating parts as low as possible, using heat treated steel and hollow members wherever opportunity offers.

#### DISCUSSION

B. F. Harris, Sou. Pac., stated that the two-thirds rule is used on that system, the over-balance in any wheel being limited to an amount which, when multiplied by 38.4 times the radius in feet of the center of gravity of the counterbalance, will not exceed 75 per cent of the static wheel load. The following method is used in correcting counterbalances: To ascertain the weight in the driving wheels which is unbalanced by the weight of attached parts, take two horses of convenient size and on these place two rails weighing not less than 72 lb. per yd. The upper surfaces of these should be made perfectly smooth and covered with a thin lubricant. Place the mounted wheels so that the journals will rest on the rails, which must be parallel and perfectly level both longitudinally and transversely. Draw one line across the face of one of the wheels, through the centers of the axle and crank pin and another line through the center of the axle at right angles to the first one. The second line indicates the position of the pin and counterbalance on the opposite

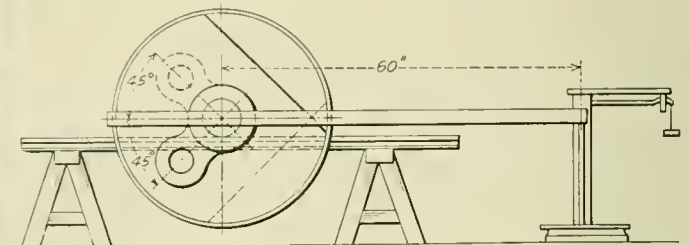

Method of Weighing Counterbalances on the Southern Pacific

wheel. On a line midway between these two, viz., 45 deg. from each, clamp a 10-ft. wooden straight-edge. Measure off from the center of the wheel on the straight-edge a distance of 60 in. and, with the straight-edge level, place a vertical support at this point with its lower end resting on a platform scale. This will weigh both counterbalances at the same time. Ascertain the weight of the vertical support and the end of the straight-edge resting on the scale, the other end being supported at a distance of 60 in. from the scale or at the center of the axle. Subtracting this weight from the former weight, the remainder will be the weight of both counterbalances corrected for a distance of 60 in. from the center. To find the effective counterbalance for one wheel at crank pin distance, multiply this remainder by the length of the lever—that is, 60 in., and by 1.4142 (secant 45 deg.) and divide by twice the crank pin radius in inches. This method is based upon the assumption that the weights in the two wheels are alike, as both are weighed together, and no means is provided for correcting for differences between the two wheels.

Several members objected to the practice of distributing the over-balance for reciprocating parts among the drivers other than the main wheel. This leaves the main wheel light and if the amount of the over-balance thus distributed is large it will cause the rod bushings to pound out and may lead to the fracturing of the rods. The use of counterbalance bobs placed on the main axle inside the frames has effected a reduction in the wear on rod bushings in such cases.

FITTING UP SHOES AND WEDGES

BY W. E. WARNER

Shop Superintendent, New York Central West, Elkhart, Ind.

The importance of having the shoes and wedges properly adjusted on a locomotive frame cannot be overestimated. A set of shoes and wedges improperly adjusted may cause an endless amount of trouble in the operation of the engine, as, for instance, the breaking of side rods and main frames, the cutting of flanges and numerous other defects to the locomotive mechanism. In order to lay out shoes and wedges correctly it is necessary that the frames be correctly laid out and machined. They should be set up in a square and level position properly adjusted, the binders in place and bolted as tightly as possible without setting up any unnecessary strain. The pedestal jaws should be chipped and filed to a

*J* and *K*, respectively. The shoes and wedges should then be put in place and the number of liners determined for each by squaring down from the points *J* and *K* on the frame, at least 1/16 in. being left for machining. After the shoes and wedges are properly lined they are clamped firmly in place by means of spreader jacks, the wedges being raised 1/2 in. from the binder. From the points *L* and *M* on the frame lay-off arcs at *T* and *R* on the shoes and wedges such that *LT* will equal *MR*, this length being such that *T* and *R* will be well on to the shoe and wedge. Lay-off arcs at *U* and *S* such that *TU* = *RS*.

Referring to Fig. 3—From the point *M* on the line *AB* erect a perpendicular *PQ* by the following method: Lay-off *MN* on *AB* equal to *MO*; with *O* and *N* as centers draw arcs of equal radii on the shoe intersecting at *P* and *Q*. A line drawn through the intersection of these arcs will be perpendicular to *AB*. Then locate the points *R* and *S* on this line, these points to serve as gaging points. Locate *S'* on the inside of the shoe from a straight edge extending between the frames, as shown in Fig. 3, and set square to the frames by squaring both ends of the straight edge from the line *PQ* on both sides of the engine. Then set an adjustable tram to the distance *M<sub>2</sub>M<sub>3</sub>* (Fig. 2), and with *R*, *S* and *S'* as centers locate *R<sub>3</sub>*, *S<sub>3</sub>* and *S'<sub>3</sub>*. To locate the gage points on the wedge set a small scale tram to the box size plus one inch, checking this distance with the points *LM* on the line *AB*, and with *R*, *S* and *S'* as centers locate the gaging points *T*, *U* and *U'* respectively on the wedge. After, by this process, all the gage points on all the shoes and wedges are laid-off, the shoes and wedges are ready for machining. When the engine is wheeled it is well to check the distances between the wheel centers and rod lengths with the standard solid trams.

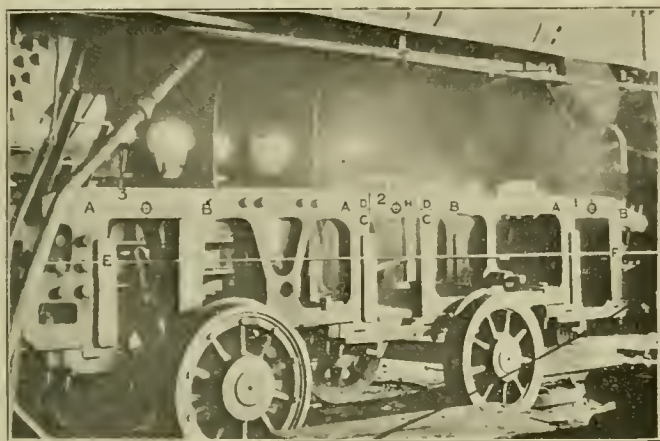

Fig. 1

plane surface, because the shoes and wedges must have a solid bearing against the jaws. Otherwise there is liability that they will be broken when too great a force is applied to them.

A method of laying out the shoes and wedges that has given entire satisfaction in every particular in many large shops is explained herewith. In this description the subscript numbers refer to the various jaws, the forward jaw being numbered 1. The "primes" indicate that the point in question is located on the inside of the frame. To locate the center of the axles on the frame refer to Fig. 1. Lay-off the line *AB*, parallel to the top of the frame, with hermaphrodite calipers at any convenient distance below the top of the frame. With one leg of a square on top of the frame draw the vertical lines *DC* from the front and back faces of the main jaw (jaw 2 in this case) intersecting the line *AB*. Bisect the line *DD* to obtain the center of this jaw at *O*. Locate the centers *O<sub>1</sub>* and *O<sub>3</sub>* of the other jaws by means of standard solid trams of the correct length.

To locate the centers of the jaws on the other side of the engine square with those centers which have just been determined, run lines *EF* through both cylinders and parallel to the frames. Place a straight edge through the main jaws, just below this line, and square it to the lines on both sides. With parallel blocks on top of the frames square up from the straight edge and intersect the line *AB* at *H* on both sides of the engine. The position of the square is indistinctly shown in Fig. 1. Locate the center of the main jaw on the other side of the engine by transferring the distance *HO* from the first side trammed. The centers of the other jaws are located as described above.

The centers of the jaws having been located the next problem is to lay-off the size of the boxes. Referring to Fig. 2—lay-off *JK*, equal to the size of the box to be used, on each jaw such that the point *O* is equidistant from *J* and *K*. With the dividers set for 1/2 in. lay-off the points *L* and *M* from

DISCUSSION

The discussion indicated that the practice of laying out shoes and wedges outlined in the report is generally followed. Exception was taken, however, to the use of lines through the centers of the cylinders as a means of squaring the boxes on

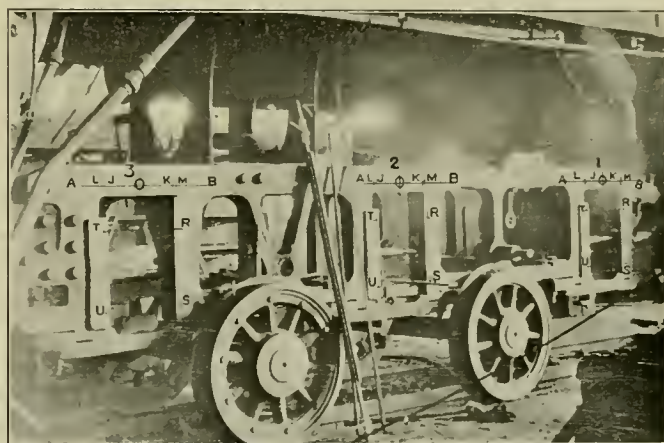

Fig. 2

the two sides of the engine, because of the ease with which these lines may be knocked out of proper adjustment. The use of the fish-tail tram is preferred in some cases, for this reason. Although the proper laying out of shoes and wedges is necessary to prevent cut driving wheel flanges, there are other causes for this trouble. Where it exists and difficulty has been found in locating the cause, it will often be disclosed by calipering the tires. On the El Paso & Southwestern, where considerable trouble has been experienced from cut flanges due to track conditions, a water rail washer is being used with success. Water is piped from the boiler to points in front of the leading truck wheels and back of the

rear drivers, so that it is delivered to the head of the rail. The use of this device has proved more successful than flange oilers in reducing cut flanges and in keeping engines on the track on certain mine branches.

**CLASSIFICATION OF LOCOMOTIVE REPAIRS**

C. S. Williams, shop superintendent of the Pere Marquette, described their classification as follows:

Repairs are based upon a certain assigned mileage, the number of miles the engine is expected to make being regulated by the class of the locomotive and the service in which it is used. The following table shows the assigned mileage according to the service and class of locomotive:

Class	Service	Assigned mileage	Gets tubes if needed on
4-6-2	Passenger	125,000	100,000
4-4-2	Passenger	90,000	80,000
4-6-2	Freight	75,000	65,000
4-3-0	Passenger	75,000	65,000
0-6-0	Switch	75,000	65,000
2-8-2	Freight	60,000	50,000
2-8-0	Freight	60,000	50,000
2-6-0	Freight	50,000	45,000

The classification of repairs to engines is as follows:

*Class A*—New boiler and general repairs to machinery and tender.

*Class B*—New firebox and general repairs to machinery and tender.

*Class C*—One or more new firebox sheets with renewal of tubes and general repairs to the machinery and tender.

*Class D*—Renewal or resetting of a majority of tubes and general repairs

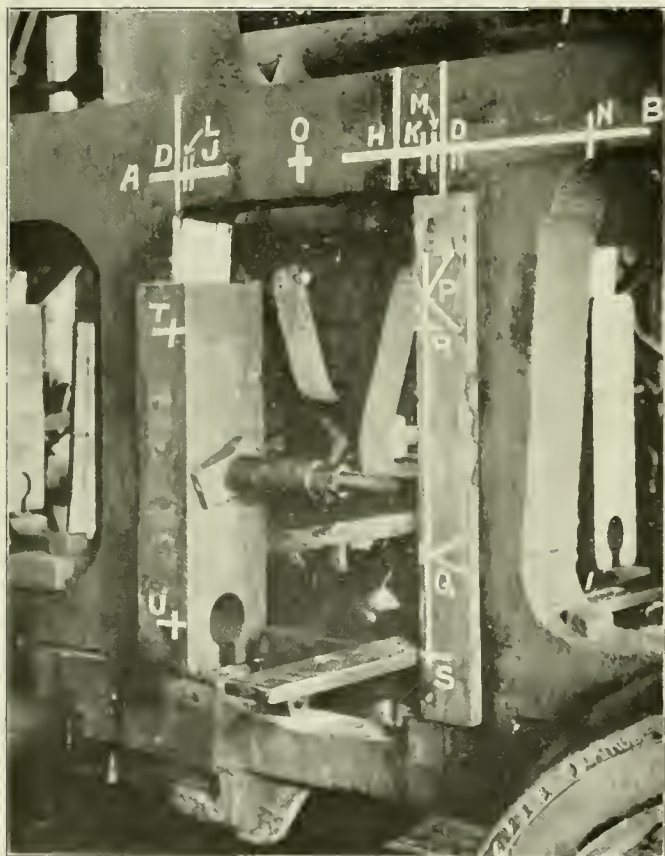

Fig. 3

to the machinery and tender. This class to include cases where boilers or fireboxes are repaired, but no entire new sheets applied.

*Class E*—Where locomotives have tires turned or partial renewal of tubes or both together with light repairs to machinery and tender.

*Class E-F*—Repairs to the machinery and tender similar to *Class E* repairs made necessary on account of breakage or failure of some important part of the locomotive not due to accident or collision, where tires may not need turning or tubes require partial renewing.

*Class F*—Slight repairs to the machinery and tender.

Accident repairs are classified under the letter indicating the approximate cost corresponding with the necessary repairs given the locomotive. The report of such accident repairs shows the classification letter assigned on the above basis with the prefix "Acc."

It is impossible to give the costs of the various repairs as classified above, due to the fact that the classification letter of repairs covers all classes of locomotives receiving that repair; however, the shops are allowed a repair credit if the total cost of such repairs, labor and material inclusive, costs over \$25. Any repair work that costs more than \$1,000, regardless of class of locomotive or class of repairs, are itemized on a form used for that purpose and authority is obtained to make the repairs, unless the engine to be repaired has made the mileage assigned according to the table shown above.

When an engine is due for the shop the road foreman of engines makes a report showing the repairs needed. This is sent to the shop when the engine is taken out of service and advises the man in charge at the shop just what is to be done when the engine arrives for repairs. When the engine arrives at the shop it is examined and if the assigned mileage has not been made an itemized report of the repairs needed is made up and authority is asked to make the repairs. This statement must also show the cost of the repairs.

The most important item in shopping engines is to mix them up if possible so that the shop will not be filled with all "heavies" at one time and all "lights" the next time so as to maintain a certain output for each month and not have it fluctuate with a large output one month and a small one the next. The repairs are planned a month or so ahead, on engines that are in service and the engines are shopped accordingly. The shop superintendent and general foreman are furnished with a statement each month showing the engines in their district, their mileage and tire wear, and as the repairs are based upon the mileage and tire wear it is very easy to pick out the engines that will be soon due for repairs and plan accordingly, working, of course, in harmony with the man directly in charge of the engines.

The engines are dated out as soon as they are taken in the shop and the length of time given for the repairs is governed by the class of repairs the engine is to receive.

A weekly meeting is held with the shop foremen and sub-foremen and a list is made up showing engines due out for that week. Copies of the list are given to the foremen, sub-foremen and all leading workmen. This list also covers the engines that are expected for the following week. Everyone works to the list and when their work is completed on one engine they move on to the next.

The store department orders the material and makes requisitions according to the consumption of material, always carrying enough staple articles on hand to meet all demands. The material is all machined on shop orders and placed back in the store stock ready for use when needed, which does not cause any delay to repairs.

In contrast to this system may be mentioned the following classification in use on one road where the repairs are based upon cost alone:

"Light Repairs" .....	\$250 to \$500
"Heavy Repairs" .....	\$500 to \$1,250
"General Repairs" .....	\$1,250 to \$1,750
"Rebuilt" .....	\$1,750 and over

It will be noted that there is no mileage specified for boiler tubes or general repairs and that the classification does not give any idea of the actual repairs the engines receive. For instance if an engine receives a new set of tires and new tubes the cost would be high and yet the engine would receive minor repairs in connection with the new parts, while on the other hand another engine of the same class may have the tires turned, tubes reset and other heavy repairs without using much material and be a much better engine as far as condition goes and yet not cost nearly as much. The difference in cost may mean a "heavy" for the best repaired engine and a "general" or "rebuilt" for the engine that received a lot of new material and not so much repair.

Another point about this method is that an engine can be taken in the shop two or three times a year and if \$250 is spent the work will be credited to the shop. On the other hand, if an engine is in for light repairs, the cost for them being \$225, or \$25 below the lowest figure in which a repair is allowed, it is not fair to the man in charge of the shop not to be allowed credit for the work and it is not fair to the company when the shop man, knowing that the cost is too low to receive credit for the repairs, transfers the needed \$25 from some other engine to get the needed amount of \$250.

This method of classifying repairs does not give any one a fair chance and causes quite a loss to a railroad. If an engine receives a repair and has to make a certain number of miles before being repaired again, every one that has anything to do with that engine in the mechanical department does all that is possible to get the mileage, as he does not want to assume the responsibility his neglect of needed running repairs may cause. It also gives the railroad company the information they want regarding the kind of work that is being done and gives them full value for the money they are spending on repairs. In order to obtain the maximum efficiency in locomotive repairs it becomes absolutely necessary to classify repairs.

W. W. Scott, general foreman of the Delaware, Lackawanna & Western, described the classification of repairs used at the Buffalo terminal of that road as follows:

- Class No. 1. Rebuilt.
- Class No. 2. New firebox and general repairs to machinery.
- Class No. 2A. New firebox sheet or sheets and general repairs to machinery.
- Class No. 3. General repairs to machinery to cost \$500 or over.
- Class No. 4. Repairs to machinery to cost \$100 to \$500.
- Class No. 5. Light repairs, labor to cost \$50.

It will be noted that full credit is given for all classes of repairs made at shops or enginehouse terminals, the light repair classification is often done at enginehouses without calling upon the back shop for labor assistance and the forces so employed receive credit for output and the work is not chargeable to running repairs.

It has been the practice on other railroads with which I have been connected, to handle light repairs in enginehouses with the regular force where the cost has run up to \$350 and no output credit given for the operation. It does not seem fair to charge such an amount to running repairs. The cost of engine-house expense should include only such expense as is necessary to maintain a locomotive in a safe and revenue producing condition ready for service after reasonable detention at the engine-house for repairs, grooming, coal, water and inspection.

In order that the mechanical department may obtain complete information relative to the condition of the power and the amount of service it is possible to obtain from each engine before the shopping period, the master mechanic calls a meeting each month of the general foremen, the general boiler foremen, the boiler inspectors, the division roundhouse foremen, the road foremen of engines, the traveling foremen and the chief clerks, all of whom come prepared with detailed information on each locomotive in general and its appurtenances in particular. A medical doctor is no more critical in his diagnosis of a patient's condition than is the mechanical department in determining the condition of its locomotives. After these reports have been received the locomotives are divided into six classes, as follows:

- Class 1 locomotives are serviceable for a period of 9 to 12 months.
- Class 2 locomotives are serviceable for a period of 6 to 9 months.
- Class 3 locomotives are serviceable for a period of 3 to 6 months.
- Class 4 locomotives are serviceable for a period of 1 to 3 months.
- Class 5 locomotives are in the shops at Buffalo.
- Class 6 locomotives are locomotives belonging to the Buffalo division in the shops at Scranton.

From this engine condition report the proper classification of the repairs is given to each engine before it enters the shops. The department foremen are given a copy of this

report so that each one knows what material will be needed when the engine does come into the shop, and the storekeepers are advised as to the material that will be needed. Every mechanical foreman has a convenient and intelligent report of the condition of each locomotive on the division, and there is no occasion to fear the inspection of the Federal and State authorities.

#### DISCUSSION

From the discussion of this report it appears that there is a wide diversity in the methods of classifying locomotive repairs used on different roads. The methods outlined in the report are those most generally used but on some roads repairs are divided into as high as 12 or 14 different classifications.

L. A. North, Illinois Central, advocates the use of cost of material as a basis of classification, in order to secure comparable results on different railroads. Owing to the wide variation in the cost of labor in different localities the total cost of repairs is not comparable, whereas the cost of material will vary but slightly throughout the country.

M. J. Gunther, El Paso & Southwestern, stated that the mileage of switch engines between shoppings has been greatly increased by the use of recording speed indicators. Before these instruments were used an arbitrary allowance of 72 miles per day was credited to each switch engine. On this basis it was difficult to secure the allotted mileage from the engines between shoppings. On equipping the engines with speed recorders, however, it was found that they were actually making from two to three times the actual miles which were being credited to them.

#### RELATION OF FOREMEN TO MEN

BY T. E. FREEMAN  
General Foreman, Duluth & Iron Range

Leadership is one of the world's most precious possessions. For the common good, leadership should be cherished and encouraged and allowed to reap its full reward. We must continue to keep wide open for every one, for the man of one talent and for the man of many talents, the golden gate of opportunity. Foremen should keep their assistants in touch with all their work and correspondence, so that they will be able to answer any questions which pertain to the shop during the foreman's absence.

A foreman should never be domineering, manifesting a spirit and a disposition that he knows it all. In doing his work, if a man offers a suggestion, listen to him. If it answers the purpose, use it. It will make him feel good, and will draw out the best that is in the man, and will encourage all of the men to think. If his way is not practicable, tell him kindly why it is not and his confidence and respect will still be retained. Some men may take advantage of kindness. This is the exception and not the rule. Do not ill-treat all the men because five or six are ungrateful and do not appreciate the interest taken in their behalf.

There are two very important factors in getting out work: First, the man's ability to do the job. Second, his willingness to do it. To get the best results, the foreman should be in close touch with his men. Study, if possible, the character and disposition of the men. This will help in distributing the work to the best advantage. Nationality, religion, politics, or personal friendship should have no place in the shop. All men should be treated the same. The foreman should be firm, but kind and just, letting his men know what he wants and what is expected of them. Never countenance or encourage talebearing. A foreman's character should be such as will appeal to his men in everything that stands for good, pure and upright manhood. When orders are issued it should be seen that they are obeyed. If at any time it is necessary to correct or call any of the men to account for neglect of duty, do it privately, never publicly

or while angry. Never swear at the men. To punish or make unkind remarks to men in the presence of others, lowers the standing of the foreman in the estimation of the men, and nothing will be accomplished.

*Should a Foreman Be a Leader or a Driver?*—In answer to the question: "Should a foreman be a 'leader' or a 'driver'?" some may say, it is necessary to be both, for there are men who have to be driven, as mules are driven, in order to get them to work. I do not agree with this assertion, first, because I do not believe it is in harmony with human nature, and second, I do not believe it is true. The very essence of good foremanship—as of good leadership—is co-operation. Men like to work with—not for—a man who shows some regard for them, who is fair with them, who is thoughtful for their welfare. And where men like to work the best results are obtained. The swearing, driving foreman has no place in modern efficiency. The modern methods are to get the best out of workmen by bettering the men themselves.

The foreman who is a leader, who possesses and exercises the essentials of leadership, will have a loyal and, usually, efficient following. His men will be with him rather than under him. They will do their best for him because he does his best for them. They will respect him because he respects them. They will be fair with him because he is fair with them. They will advance him because he advances them. And in thus treating his men he puts himself in the surest way for still wider and more important activities, for a still higher and more responsible trust.

The foreman who is a "driver" must keep on driving to get results. He cannot expect loyalty, for loyalty comes voluntarily; it cannot be compelled. He need not look for co-operation because his methods arouse antagonism. He must remain always back of his men rather than have his men back of him. As a "driver" he is likely to be kept on the lower levels where driving is supposed to be needed. His methods are most likely to stand as an effective bar to his own advancement. The leader is always at the head of his men. The driver, of necessity, must remain in the rear. When opportunity for advancement comes the man in front has the first chance. The same friendly relations should exist between the foreman and his men as between the master mechanic and the foreman.

Lack of attention to details by foremen is a contributory cause of mental disturbance in employees, which in turn interferes with their capacity for production. I refer particularly to the failure of foremen to interest themselves in the matter of conveniences for employees in the handling of their work, as well as providing for their bodily comfort. It is a common condition in many shops to find employees trying to make headway with defective tools.

*Quality and Shop Output.*—Great claim is generally laid on the importance of a large shop output, the common basis of measurement being the number of locomotives a month which can be repaired in a given shop. The ability of a foreman to increase the output of a shop is very commonly used as an indication of his value as a manager. No doubt this is a reasonably good method of arriving at an estimate of a man's ability; but there is a question of the advisability of using this as the only basis for arriving at such an estimate. Quantity is desirable and even essential in shop output. Economy demands that locomotives spend as large a proportion of the time as possible in earning money, which means that they must spend as little time as possible undergoing repairs. But there is more to the repair question than the heavy repairs made in the back shop. Most locomotive repair work is done in engine houses and it is at this point that the effect of laying too much stress on general repair shop output or quantity with a neglect of the quality of the work done makes itself most directly felt.

There are many shops in this country which are rated entirely on the number of locomotives turned out per month

in determining the output, when the railway company would be money in pocket if the output were reduced as far as numbers are concerned and steps taken to materially improve the work turned out. If the little things are not done in the general shop they will have to be done in the engine house and they may develop into larger things that will compel the return of the engine to the general repair shop long before it has made its full mileage. This is a matter which demands serious attention from higher railway officers as well as shop superintendents and foremen. The maximum possible output of any shop is desirable provided it can be accomplished by the highest quality of workmanship. Quantity without quality will invariably result in increased maintenance charges and decreased mileage between shop-pings; quantity and quality combined will tend toward economy in locomotive maintenance and train movement.

*Economy in Labor and Material.*—There is wide opportunity for economy in bringing railway men in general and shop employees in particular to realize that time and material which they can save in their personal work can have a direct and considerable bearing on the condition of the company's treasury and consequently on their own prosperity. While means should be taken to instill these ideas into the older employees, the place for the most earnest efforts is in the apprentice school, and in this connection the simpler the explanation can be made the better. In many instances the lesson will be kept in mind and while it seems a hopeless task to bring all employees to a correct understanding of such matters, a continued process of education and enlightenment will result in a surprising increase in the efforts of individual employees toward economy.

#### DISCUSSION

One of the difficulties which confront many general foremen today is the handling of foreign labor. It has generally been the practice to work the various nationalities in gangs by themselves but this has often led to a shortage of labor owing to the difficulty of keeping sufficient men. If one man became dissatisfied it was not unusual for the whole gang to quit in a body. In shops on two different roads, each confronted with the problem of handling several nationalities, this trouble has been solved by breaking up the solidarity of the gangs and mixing the various nationalities. Some trouble was experienced in putting the change into effect, but after the practice had been established no further difficulty in keeping men was experienced.

#### OTHER BUSINESS

The following officers were elected to serve for the ensuing year: President, L. A. North, Illinois Central, Chicago; first vice-president, W. T. Gale, Chicago & North Western, Chicago; second vice-president, J. B. Wright, Hocking Valley, Columbus, Ohio; third vice-president, George H. Logan, Chicago & North Western, Clinton, Ia.; fourth vice-president, A. E. Warner, New York Central, Elkhart, Ind.; secretary-treasurer, William Hall, Chicago & North Western, Winona, Minn.; chairman of the executive committee, E. E. Griest, Pennsylvania Lines, Ft. Wayne, Ind.

The by-laws were amended to make the office of secretary-treasurer permanent instead of elective annually.

The following are the topics for consideration at the 1917 convention: (1) Engine Failures, Their Causes and Responsibility, and What Constitutes an Engine Failure; (2) Methods of Meeting the Requirements of Federal Inspection Laws; (3) Alinement of Locomotive Parts to Insure Maximum Service and Minimum Wear, and (4) What Interest Has the Locomotive Foreman in Car Matters?

*PROPER TREATMENT OF RUBBER GASKETS.*—When packing a flange or cylinder with a rubber gasket, all oil and grease should be wiped from the surface of the metal.—*Power.*





for case hardening in that time; for instance, in 1879 we used old leather belting or old shoes—in fact, anything made of leather that was not useful for anything else—bones gathered from around abattoirs and in the fields, horse hoof borings gathered from country smith shops, mixed with some charcoal and three per cent prussiate of potash. For the past two years we have been using a manufactured article which gives the metal a very hard surface, 1-16 in. or 3-32 in. thick in from five to eight hours steady heat according to the size of the box and pieces to be hardened. We can reclaim and use over again about fifty per cent of this compound.

## CARING FOR LOCOMOTIVE TOOLS

BY JOHN F. LONG

All tools should be removed from an incoming locomotive as soon as the crew leaves. Pick handles, shovel handles, wrench handles, etc., should be renewed if necessary; oil cans should be cleaned and soldered and new tops applied where necessary; water coolers should be thoroughly cleaned and scalded. All tools should be carefully checked and any

shown is not of the most modern type, it is used for the purpose of illustrating what can be done with the materials in the hands of almost any terminal foreman.

A system of careful checking of supplies issued to engines, and a careful investigation of cases where supplies are lost, will cut down the cost of engine tools surprisingly.

## DOES IT PAY?

BY A. E. M.

Some years ago the writer was asked by a prominent superintendent of motive power to make a trip over his road and determine the reason why so much metallic packing was used on the locomotives. The conditions found were, to say the least, not what they should be. In fact they were so bad that the superintendent was on the point of asking for a large appropriation to enable him to change over to a different type of metallic packing, hoping thereby to improve these conditions. Many roads have done this very thing and are still doing it, but do they get the proper results? They undoubtedly do for a little while, but they are soon back to where they started, and the reason for this is very plain. Why not



A Homemade Building for Locomotive Tools and Supplies

shortage reported. Many enginehouses do not have a proper room or building to care for engine tools and supplies. Such a building, however, may be easily provided. In the engraving there is shown a small tool house which was built from scrap car lumber and old galvanized roofing. This building is located near the incoming track. The photographs also give an idea of the interior of the building. At one end a vise has been installed to be used in making repairs to the various tools when required. A place is also provided for records. A wash basin is provided and special attention has been given to heating and lighting.

A side view of the interior shows the scoop arrangement. Note the rack for ash hoes and clinker hooks. Another of the views shows the arrangement made to take care of the various oil cans, torches, buckets, etc. While the building

have specialists on packing at each roundhouse; give them every assistance necessary to keep the packing in good condition, keep the guides in line, the piston rods round and true, and the piston heads and cylinder packing in good shape. This was done by the superintendent of motive power above mentioned, and although it costs him something to keep the equipment up he found it unnecessary to ask for the large appropriation to make the change to a new type of packing, and what he has saved has bought all his packing for a long while. Think it over! It pays!

**PREVENTION OF SCALING IN BOILERS.**—The formation of scale in a boiler may be prevented, it is stated, by applying a coat of aluminum paint to its inside surface.—*Journal of the American Society of Mechanical Engineers.*

# New Devices

## NATIONAL CAR DOOR

The National door is a car door without a track. It is supported by strong brackets secured to the side sill, its weight and all stresses produced by it being transmitted direct to the underframe. No load is imposed on the superstructure or roof structure and the danger of binding, as in the case of a door hung on a track at or near the eaves of the roof, is obviated. The brackets, usually four at the door opening and two at the back of the door opening, are fitted with rollers  $3\frac{1}{2}$  in. in diameter, the door traveling freely on these rollers. To insure a close fit when the door is closed the rollers at the door opening have a beveled face so that

boards can be applied at any time. The corner gussets prevent the frame strips from loosening or turning out in case the wood deteriorates. The door posts in the case of double sheathed cars project about an inch outside of the sheathing and the flooring at the doorway is carried out flush with the face of the post, the door being made wide enough to lap over the back post. The top and front frame strips are made of Z-bars, having one leg bolted to the door and the other leg extending out from the door and interlocking with Z-bars or other suitable members on the car. The bottom frame strip is also of Z-bar section, one leg being bolted to the door and the other extending down and behind the rollers described above. The back frame strip is an angle with

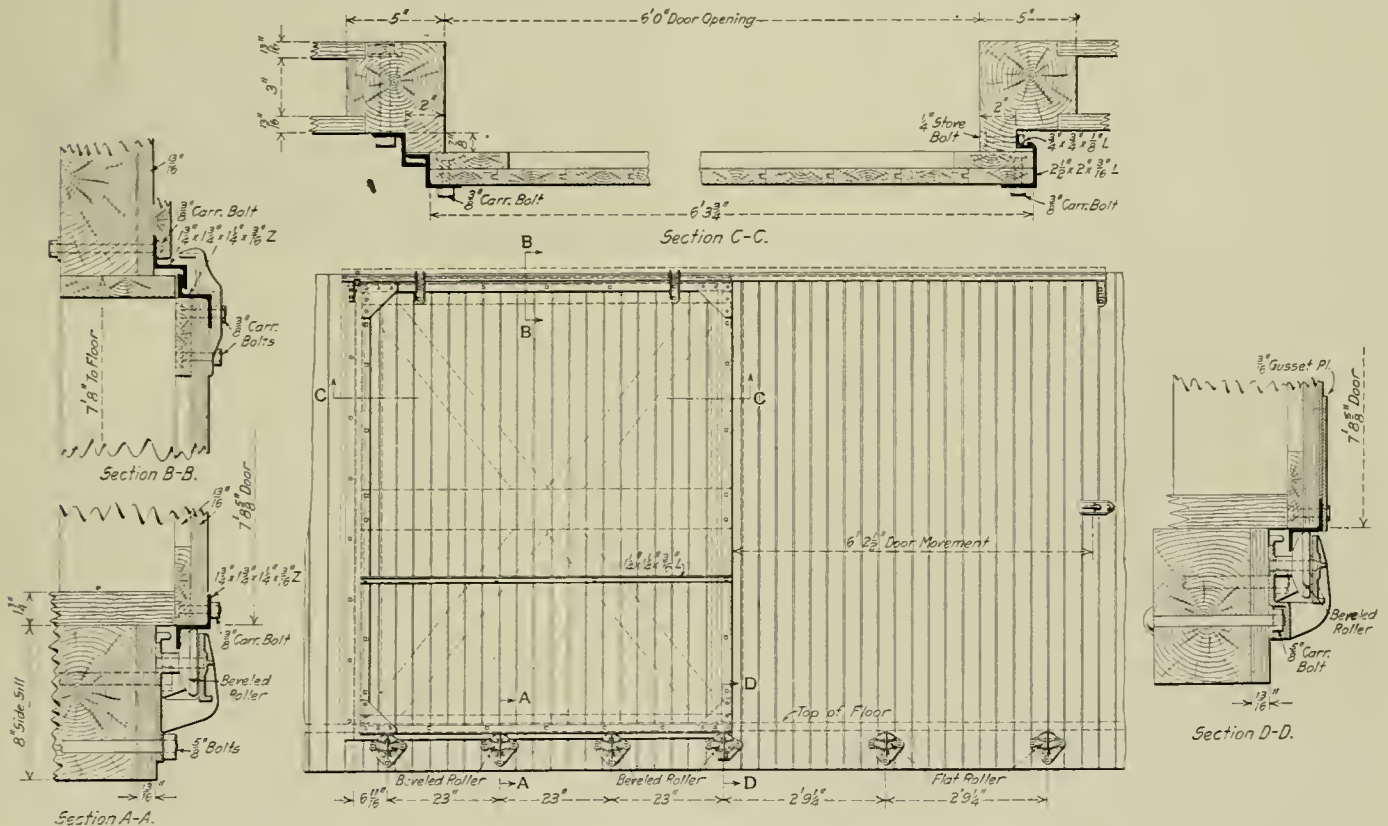

National Car Door Applied to Double Sheathed Box Car

the door is moved inwardly as they rotate. The rollers back of the door opening are flat faced, being inserted in brackets with guide lugs to prevent the door marring the sheathing, but still allowing ample freedom of movement. On steel frame single sheathed box cars the roller brackets are secured with rivets and on double sheathed box cars the roller bracket at the back of the door is so arranged that one of the bolts is concealed, thereby making it inaccessible and thus preventing burglarizing.

The door has a steel frame with gusset plates at the corners and a steel brace extending from the front strip to the back strip. This provides a rigid construction which will keep in alinement and protect the wood, and to which new

one leg bolted to the door and the other, slightly longer than the thickness of the door, bent inward to close over the leg of a small angle secured to the back door post. This construction makes the door weather proof and spark proof. The interlocking of the door at all sides also prevents it from being sprung open and the car entered by thieves when once it is closed.

Safety hangers are provided to carry the door on the door hood in the event the car to which it is applied is side-wiped and the bottom roller brackets knocked off. In such a case the door would still be operative. Safety door stops are also provided in case the ordinary back stop is knocked off. These are extra precautions taken to prevent the loss of the



The spindle is mounted in combination radial and thrust bearings, the front bearing being 6.69 in. in diameter and the rear bearing 4.33 in. in diameter. These bearings are of the radial type, the raceways encircling the balls on the thrust side far enough to prevent any wedging action and to provide a reaction at the proper angle to take care of both the thrust and radial loads. These bearings are very accurately fitted and when properly opposed in order to prevent any tendency toward longitudinal motion of the spindle,

slightly wavy surface on the finished work. The bearings are manufactured by the Gurney Ball Bearing Company, Jamestown, N. Y.

### HYDRAULIC BRIQUETTING PRESS FOR METAL BORINGS

The accompanying photograph illustrates a new design of hydraulic press recently brought out by The Hydraulic Press Manufacturing Company, Mount Gilead, Ohio, for use in briquetting metal borings, turnings, etc., so that they may be remelted without the loss of valuable ingredients and to prevent oxidation. It also puts the material in a convenient form for handling. The press is of the four-rod inverted cylinder type and is built in three different sizes and

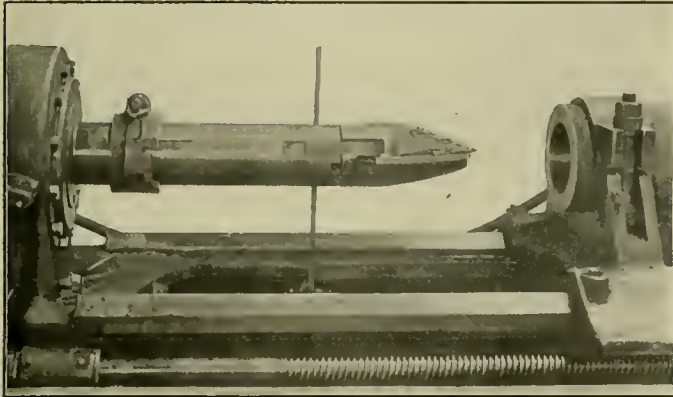

Boring Head for Finishing Interior of Shells. Overhang is 36 in.; Distance Between Bearings 33 in.

provide an accuracy of alinement of the spindle, which will be maintained permanently, subject to practically no wear, whereas the maintenance of alinement with the ordinary spindle bearings is somewhat difficult owing to the effect of wear. One of the photographs shows clearly the extent of overhang of the cutting tool which the spindle must support. The tool is for machining the arch on the interior of the nose of the shell, which is secured to the carriage of the machine and fed onto the tool.

The spindle of the lathe is worm driven, the worm wheel

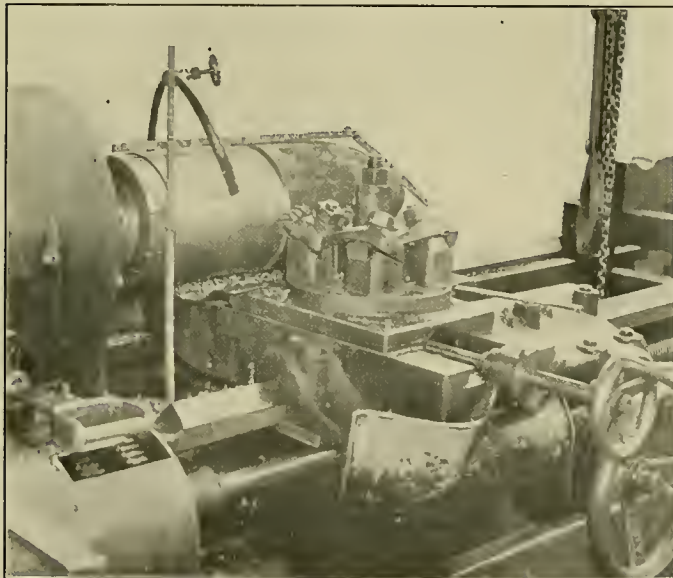

Shell Mounted on the Mandrel for Finishing the Outside

being mounted on the spindle and driven from the underside by a worm mounted on the cone shaft, which is located in front of the machine. This arrangement provides for high speed operation of the belt cone, enabling a 3-in. belt to provide ample power for the machine, the drive being especially steady in its action and entirely free from chatter.

This is one of the first successful applications of ball bearings to a lathe spindle, difficulty usually having been encountered from a tendency of the ball bearings to produce a

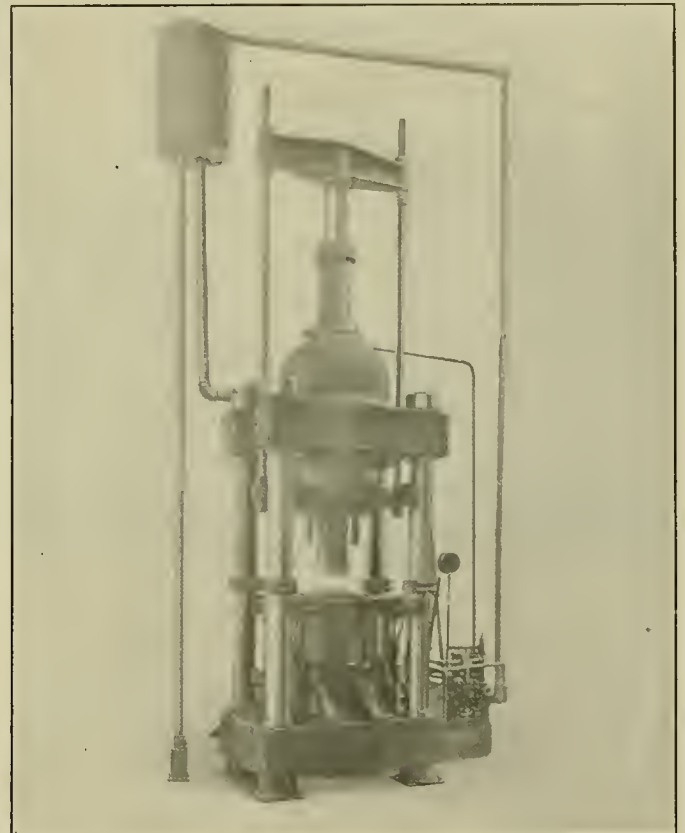

Metal Briquetting Press

pressure capacities, viz., 1,000 tons, 750 tons and 300 tons. The illustration shows the 1,000-ton press.

The briquet forming mechanism of these presses has been patented in the United States and Canada, as well as in several foreign countries. It is capable of forming a briquet quickly and of uniform density. This is accomplished by placing the material in a floating mold which is supported by four springs; when the pressure is applied upon the material from above the friction of the material on the sides of the mold causes it to move down over a stationary plunger which projects into the mold from below. Pressure is thus applied on the bottom as well as on the top of the material and its density is made uniform. After being formed, the briquet is ejected from the mold by applying the pressure of the main ram upon the briquet, the lower plunger being removed by the movement of a controlling lever. The large press is provided with a surge tank, the base of which is located higher than the main cylinder. By a simple movement of the valve lever the plunger drops to the material in the mold and the main cylinder is filled with fluid by suction of the ram as well as by the weight of the fluid. The first stroke of the pump then starts the pressure upon the

material. The main ram is returned by means of the auxiliary ram located at the extreme top of the press, this action returning the fluid to the surge tank. The presses are solidly built throughout. The strain rods are made of heat treated forged steel and have solid heads and collars. The main ram is guided by babbitted bearings working upon the strain rods and by a long bearing in the throat of the cylinder and the floating mold is also guided by babbitted bearings.

### BOX CAR DOOR LOCK

The Triplex Lock Company, Michigan City, Ind., has placed on the market a new box car door lock, which provides a means for locking the door with a padlock in addition to the regular seal method. The lock is so constructed that additional power is obtained in closing and opening the door through a segmental gear and rack, as indicated in the illustrations. As the door approaches the closed position the rack, which is attached to the door, is thrown over and passes through a slot in the gear housing on the door post.

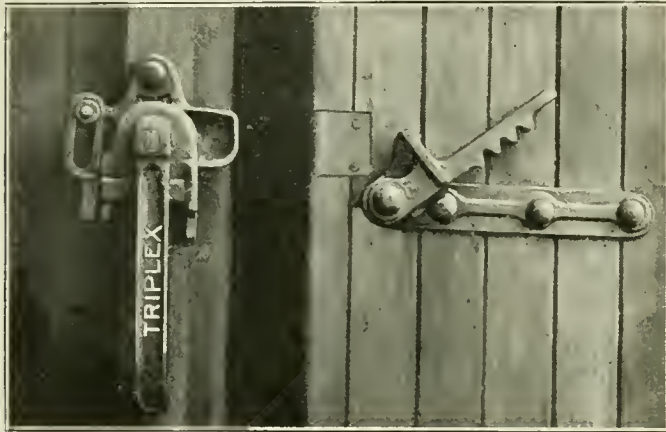

Triplex Lock with the Car Door Open

This rack meshes with the gear, which in turn is operated by the handle shown. By twisting the handle the door is drawn to its shut position, a multiplication of power of 9 to 1 being obtained. A slotted lug on the rack abuts a corresponding lug on the gear housing through which the padlock is passed. The seal pin passes through a hole in the end of the rack and the seal is passed through the pin and a lug on the gear housing, as shown in the second illustration.

In opening the door this same increased power is available and eliminates the necessity of using crow bars and sledge hammers, which so often injure the car doors. The rack

attachment also has the added advantage in that in case of a sagging door sufficient power may be exerted to bring the door up tight against the stop, permitting it to be locked, as above described. It will also be noted that a bracket on the

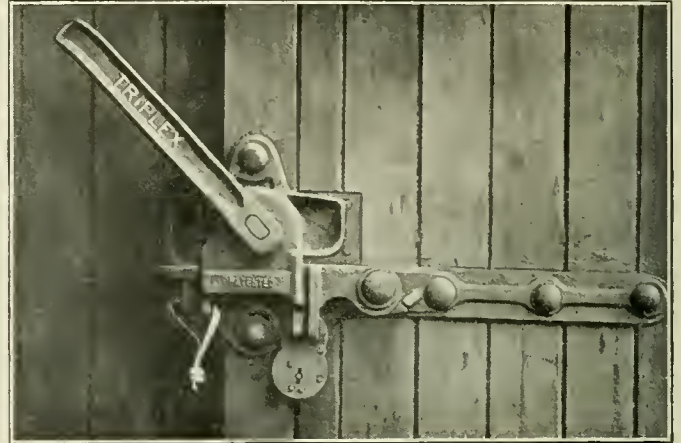

Triplex Lock with the Door Shut and Locked

gear housing forces the door up tight against the door post as the door is drawn to the closed position; this permits the lock to operate freely, the door thus being securely fastened.

### URANIUM IN HIGH SPEED STEEL

One of the recent developments in high speed steel is the use of Uranium, which possesses marked deoxidizing and denitrogenizing effects when applied to steel. A number of tests have recently been made under the direction of the Standard Chemical Company at several shops in the Pittsburgh district, in which the performance of Uranium steel has been compared with that of other high speed steels. The results of these tests are given in the table below.

The tools marked A, B, C and D were of high speed steel and those marked U were of Uranium steel.

The effect of Uranium in tool steel is to increase the toughness and largely eliminate brittleness. The heat treatment of the Uranium alloys presents no new features, as they are handled in the same manner as other high speed steels, being heated to between 2,200 deg. F., and 2,300 deg. F. and then, when drawn back, to 900 deg. F. Air quenching is preferable although oil may be used.

The production of Uranium high speed steel is now being taken up by several tool steel manufacturers. Both ferrous and non-ferrous alloys of Uranium are supplied by the Standard Alloys Company, Pittsburgh, Pa.

Tool.	Material.	Feed.	Speed.	Depth of cut.	Remarks.
U-a	Locomotive axle.....	3/32 in.	103 f.p.m.	3/8 in.	Ran 5 in.
A	Locomotive axle.....	3/32 in.	103 f.p.m.	3/8 in.	Ran 2 in.
U-a	Locomotive crank pin.....	1/16 in.	74 f.p.m.	5/8 in.	Ran 12 in.
A	Locomotive crank pin.....	1/16 in.	74 f.p.m.	5/8 in.	Ran 2 in.
U-a	Locomotive crank pin.....	1/16 in.	64 f.p.m.	5/8 in.	Ran 8 in.
A	Locomotive crank pin.....	1/16 in.	64 f.p.m.	5/8 in.	Ran 2 in.
U-1	12-in. shaft .50 per cent carbon.....	1/16 in.	75 f.p.m.	3/4 in.	Went over once, distance of 14 in. On second lap went 3 in.
B	12-in. shaft .50 per cent carbon.....	1/16 in.	75 f.p.m.	1/4 in.	Went distance of 4 in.
D	12-in. shaft .50 per cent carbon.....	1/16 in.	75 f.p.m.	1/4 in.	Went distance of 1 in.
U-1	8-in. shaft 7 ft. 5 in. long.....	1/16 in.	51 f.p.m.	5/8 in.	Went over twice. Cut changed to 3/8 in. on second turn.
C	8-in. shaft 7 ft. 5 in. long.....	1/16 in.	35 f.p.m.	5/8 in.	Did not go 1 in.
U-1	6-in. shaft.....	1/32 in.	75 f.p.m.	5/8 in.	Ran 18 in.
U-2	6-in. shaft.....	1/32 in.	75 f.p.m.	5/8 in.	Ran 13 in. Speed increased to 90 f.p.m. and ran 11 in. Tool still good.
B	6-in. shaft.....	1/32 in.	75 f.p.m.	5/8 in.	Ran 11 in.
U-4	10-in. shaft.....	1/16 in.	60 to 65 f.p.m.	5/8 in.	Ran 8 in.
U-2	10-in. shaft.....	1/16 in.	65 f.p.m.	5/8 in.	Ran 4 in. Speed increased to 80 f.p.m. and ran 3 1/2 in.
U-1	12-in. shaft, 22 in. long.....	3/64 in.	55 f.p.m.	5/16 in.	Ran 16 in.
U-5	12-in. shaft, 22 in. long.....	3/64 in.	55 f.p.m.	5/16 in.	Ran 15 in.
B	12-in. shaft, 22 in. long.....	3/64 in.	55 f.p.m.	5/16 in.	Ran 2 1/2 in.
U-8	12-in. forgings.....	1/16 in.	45 f.p.m.	5/8 in. to 3/4 in.	Ran 8 1/2 in. Most of time the nose of tool was directly on scale.
U-8	12-in. forgings.....	1/16 in. to 1/10 in.	38 f.p.m.	15/16 in.	Ran 127 in. Time 3 hrs. Speed increased to 65 f.p.m. after 105 in.
U-8	12-in. forgings.....	1/16 in.	60 f.p.m.	1 1/16 in.	Ran 12 in.

# Railway Mechanical Engineer

(Formerly the RAILWAY AGE GAZETTE, MECHANICAL EDITION  
with which the AMERICAN ENGINEER was incorporated)

PUBLISHED ON THE FIRST THURSDAY OF EVERY MONTH BY THE  
SIMMONS-BOARDMAN PUBLISHING COMPANY

EDWARD A. SIMMONS, *President*                      L. B. SHERMAN, *Vice-President*  
HENRY LEE, *Vice-President and Treasurer*      M. H. WIUM, *Secretary*  
WOOLWORTH BUILDING, NEW YORK, N. Y.  
F. H. THOMPSON, *Business Manager*, CHICAGO.

Chicago: Transportation Bldg.                      Cleveland: Citizens' Bldg.  
Washington: Home Life Bldg.  
London: Queen Anne's Chambers, Westminster.

Roy V. WRIGHT, *Editor*  
A. C. LOUDON, *Managing Editor*  
R. E. THAYER, *Associate Editor*                      C. B. FECK, *Associate Editor*

Entered at the Post Office at New York, N. Y., as mail matter of the second class.

Subscriptions, including the eight daily editions of the *Railway Age Gazette* published in June in connection with the annual conventions of the Master Car Builders' and American Railway Master Mechanics' Associations, payable in advance and postage free: United States, Canada and Mexico, \$2.00 a year; Foreign Countries (excepting daily editions), \$3.00 a year; Single Copy, 20 cents.

WE GUARANTEE that of this issue 8,600 copies were printed; that of these 8,600 copies, 7,392 were mailed to regular paid subscribers, 106 were provided for counter and news companies' sales, 491 were mailed to advertisers, exchanges and correspondents, and 611 were provided for new subscriptions, samples, copies lost in the mail and office use; that the total copies printed this year to date were 82,900, an average of 8,290 copies a month.

The RAILWAY MECHANICAL ENGINEER is a member of the Audit Bureau of Circulations.

VOLUME 90

OCTOBER, 1916

NUMBER 10

## CONTENTS

### EDITORIALS:

Help Push Your Association.....	493
Fuel Cost and Fuel Economy.....	493
The Enginehouse and the Tool Foreman.....	493
Standard Methods for Railway Shops.....	493
Functions of the Mechanical Associations.....	493
The Microscope and Boiler Steel.....	494
General Foremen and the Car Department.....	494
The Purchase of Paint on Specifications.....	494
Corrosion and Boiler Steel.....	494
Proper Braking of Long Passenger Trains.....	495
Speed Indicators on Switch Engines.....	495
New Books.....	495

### GENERAL:

Boiler Expansion Experiments.....	496
Pulverized Fuel for Stationary Boilers on the Missouri, Kansas & Texas.....	499
Four Cylinder Atlantic Type Locomotive, Great Northern of England.....	502
Chart for Determining the Expansion of Metals.....	504
Clipboard for Analyzing Indicator Cards.....	504
Locomotive Boiler Efficiency.....	505
Present Day Locomotive Problems.....	509

### CAR DEPARTMENT:

Caboose for the N., C. & St. L.....	511
Belt Rail Applied to Union Pacific All-Steel Automobile Cars.....	513

Gage for Checking the Location of Wheels on the Axle.....	514
Car and Locomotive Painters.....	515

### SHOP PRACTICE:

Injector Steam Pipe Roller and Expander.....	525
Union Pacific Extension Exhaust Pipe Seats.....	525
Straightening Press for Steel Car Members.....	526
The General Foremen's Convention.....	527
Jacking Stall for Steel Car Repairs.....	535
Case Hardening.....	535
Caring for Locomotive Tools.....	536
Does It Pay?.....	536

### NEW DEVICES:

National Car Door.....	537
Simplex Coach Seat.....	538
Ball Bearings in Lathe Construction.....	538
Hydraulic Briquetting Press for Metal Borings.....	539
Box Car Door Lock.....	540
Uranium in High Speed Steel.....	540

### NEWS DEPARTMENT:

Notes.....	541
Meetings and Conventions.....	542
Personals.....	542
Supply Trade Notes.....	544
Catalogues.....	548

The Chicago, Milwaukee & St. Paul announces a wage increase of 2½ cents an hour for the 200 or more boiler-makers and helpers employed between Mobridge, S. D., and the Pacific Coast. In future the average wage of the boiler makers on this system will be 49 cents and helpers 25 cents an hour. Nine hours will constitute a day's work.

### CARS AND LOCOMOTIVES ORDERED IN SEPTEMBER

September car and locomotive orders showed a decided increase over those for August. The totals were as follows:

	Locomotives	Freight Cars	Passenger Cars
Domestic.....	253	8,852	122
Foreign.....	6	4,000	...
Totals.....	259	12,852	122

The foreign orders were comprised of the following: United Railroads of Yucatan, 2 ten-wheel locomotives, Bald-

win Locomotive Works; Laurence Marques, for Portuguese East Africa, 3 Santa Fe type locomotives, Baldwin Locomotive Works, and the Guanica Centrale Railway (Porto Rico), one six-wheel switching locomotive, American Locomotive Company. The largest domestic locomotive order was for 230 locomotives, placed by the New York Central and divided equally between the American Locomotive Company and the Lima Locomotive Corporation.

The largest freight car order was placed by the Russian Government with the Bettendorf Company. Other large freight car orders included the following: New York Central, 1,000 gondola cars, Standard Steel Car Company; 1,000 box cars, American Car & Foundry Company, and 1,000 cars, Pressed Steel Car Company; Chicago, Milwaukee & St. Paul, 1,000 cars in company shops, and the Western Pacific, 1,000 cars, Mount Vernon Car Manufacturing Company.

The largest passenger car order was given by the New

York, New Haven & Hartford to the Osgood-Bradley Car Company, authorizing that company to proceed with the construction of 40 baggage cars.

**MEETINGS AND CONVENTIONS**

*Traveling Engineers' Association.*—The twenty-fourth annual convention of the Traveling Engineers' Association will be held at the Hotel Sherman, Chicago, October 24 to October 27, 1916, inclusive. The convention was to have been held on September 5, but was postponed on account of the threatened strike of the train-service brotherhoods. The program announced in these columns in August, and other arrangements made for the earlier date, will be adhered to in connection with the new date.

*A. S. M. E. Railroad Meeting.*—The Railroad Committee of the American Society of Mechanical Engineers has arranged a most attractive program for the meeting of the Railroad Section, which will be held during the annual meeting of the society at New York early in December. It is planned to hold the Railroad Section meeting on Friday morning, December 8, with an afternoon session if it should prove necessary. The program will include papers on Mechanical Design of Electric Locomotives, by A. F. Batchelder, Railway Department, General Electric Company; Clasp Brakes, by Thomas L. Burton, of the American Brake Company, St. Louis; and Pulverized Fuel for Locomotives, by J. E. Muhlfield, president of the Locomotive Pulverized Fuel Company.

*The following list gives names of secretaries, dates of next or regular meetings and places of meeting of mechanical associations:*

- AIR BRAKE ASSOCIATION.—F. M. Nellis, Room 3014, 165 Broadway, New York City.
- AMERICAN RAILROAD MASTER TINNERS', COPPERSMITHS' AND PIPEFITTERS' ASSOCIATION.—O. E. Schlink, 485 W. Fifth St., Peru, Ind.
- AMERICAN RAILWAY MASTER MECHANICS' ASSOCIATION.—J. W. Taylor, Karpen Building, Chicago.
- AMERICAN RAILWAY TOOL, FOREMEN'S ASSOCIATION.—Owen D. Kinsey, Illinois, Central, Chicago.
- AMERICAN SOCIETY FOR TESTING MATERIALS.—Prof. E. Marburg, University of Pennsylvania, Philadelphia, Pa.
- AMERICAN SOCIETY OF MECHANICAL ENGINEERS.—Calvin W. Rice, 29 W. Thirty-ninth St., New York.
- ASSOCIATION OF RAILWAY ELECTRICAL ENGINEERS.—Joseph A. Andreucetti, C. & N. W., Room 411, C. & N. W. Station, Chicago.
- CAR FOREMEN'S ASSOCIATION OF CHICAGO.—Aaron Kline, 841 Lawlor Ave., Chicago. Second Monday in month, except June, July and August, Hotel La Salle, Chicago.
- CHIEF INTERCHANGE CAR INSPECTORS' AND CAR FOREMEN'S ASSOCIATION.—W. R. McMunn, New York Central, Albany, N. Y. Convention, October 3-5, Indianapolis, Ind.
- INTERNATIONAL RAILROAD MASTER BLACKSMITHS' ASSOCIATION.—A. L. Woodworth, C. H. & D., Lima, Ohio.
- INTERNATIONAL RAILWAY FUEL ASSOCIATION.—J. G. Crawford, 547 W. Jackson Blvd., Chicago. Convention, May, 1917, Chicago.
- INTERNATIONAL RAILWAY GENERAL FOREMEN'S ASSOCIATION.—William Hall, 1126 W. Broadway, Winona, Minn.
- MASTER BOILER MAKERS' ASSOCIATION.—Harry D. Vought, 95 Liberty St., New York.
- MASTER CAR BUILDERS' ASSOCIATION.—J. W. Taylor, Karpen Building, Chicago.
- MASTER CAR AND LOCOMOTIVE PAINTERS' ASSOCIATION OF U. S. AND CANADA.—A. P. Dane, B. & M., Reading, Mass.
- NIAGARA FRONTIER CAR MEN'S ASSOCIATION.—E. N. Frankenberger, 623 Brisbane Building, Buffalo, N. Y. Meetings, third Wednesday in month, New York Telephone Bldg., Buffalo, N. Y.
- RAILWAY STOREKEEPERS' ASSOCIATION.—J. P. Murphy, Box C, Collinwood, Ohio.
- TRAVELING ENGINEERS' ASSOCIATION.—W. O. Thompson, N. Y. C. R. R., Cleveland, Ohio. Convention, October 24-27, 1916, Hotel Sherman, Chicago.

**PERSONAL**

**GENERAL**

A. R. AYERS, principal assistant engineer, equipment department of the New York Central Lines east of Buffalo, with office at New York, has been appointed superintendent of motive power of the New York, Chicago & St. Louis, with headquarters at Cleveland, Ohio. Mr. Ayers was born on October 26, 1878, at Toledo, Ohio, and graduated from Cornell University in 1900 as a mechanical engineer. He began railway work with the Lake Shore & Michigan Southern as a special apprentice in the same year. He was special inspector from 1903 to 1905, and in the latter year was made night engine house foreman at Elkhart, Ind. The next year he was made assistant general foreman of the Collinwood shops, and in 1907 was promoted to superintendent of shops at Collinwood, and on the latter date was appointed assistant master mechanic, with office at Elkhart on the same road. He was appointed mechanical engineer of the Lake Shore, the Chicago, Indiana & Southern and the Indiana Harbor Belt, with office at Cleveland in 1910, and in March, 1912, was appointed general mechanical engineer of all the New York Central Lines west of Buffalo, with office at Chicago. In February, 1915, he was appointed principal assistant engineer, equipment department of the New York Central, lines east of Buffalo, with office at New York, and on October 1 left that road to become superintendent of motive power of the New York, Chicago & St. Louis.



A. R. Ayers

R. E. JACKSON, master mechanic of the Virginian Railway at Victoria, Va., has been appointed superintendent of motive power with headquarters at Princeton, W. Va., succeeding F. T. Slayton, who has been assigned to other duties.

H. A. MACBETH, superintendent motive power of the New York, Chicago & St. Louis, has been appointed assistant superintendent motive power at Cleveland, Ohio.

W. H. MALONE, assistant superintendent of locomotive performance, of the St. Louis-San Francisco, has been appointed superintendent of locomotive performance with headquarters at Springfield, Mo., succeeding P. O. Wood.

R. A. PYNE has been appointed superintendent of motive

**RAILROAD CLUB MEETINGS**

Club.	Next Meeting	Title of Paper	Author	Secretary	Address
Canadian .....	Oct. 10	Railway Publicity .....	Walter S. Thompson	James Powell .....	St. Lambert, Que.
Central .....	.....	Train Rules and Disp.; Annual Outing..	John F. Mackie...	Harry D. Vought...	95 Liberty St., New York.
Cincinnati .....	Nov. 14	Annual Meeting; Banquet .....	.....	H. Boutet .....	101 Carew Bldg., Cincinnati, O.
New England.....	Oct. 10	Fuel Economy and Boiler Design.....	J. T. Anthony....	Wm. Cade, Jr....	683 Atlantic Ave., Boston, Mass.
New York.....	Oct. 20	Education of Young Men to Fit Them for Promotion .....	F. W. Thomas....	Harry D. Vought...	95 Liberty St., New York.
Pittsburgh .....	Oct. 27	Annual Meeting; Smoker and Entertainment	.....	J. B. Anderson....	207 Penn Station, Pittsburgh, Pa.
Richmond .....	Oct. 16	Fire Box Efficiency .....	J. T. Anthony....	F. O. Robinson...	C. & O. Railway, Richmond, Va.
St. Louis .....	Oct. 13	The Ubiquitous Freight Car Question and Its Elusive Answer.....	E. H. DeGroot, Jr.	B. W. Frauenthal...	.....
South'n & S'w'rn.	Nov. 16	Fire Prevention; Election of Officers.....	.....	A. J. Merrill.....	Union Station, St. Louis, Mo.
Western .....	Oct. 16	Gears and Side Rods in Electric Locomotives	G. M. Eaton.....	Jos. W. Taylor....	Box 1205, Atlanta, Ga. 1112 Karpen Bldg, Chicago.



power, eastern lines of the Canadian Pacific, succeeding J. T. Main, transferred.

P. O. WOOD, superintendent of locomotive performance of the St. Louis-San Francisco has been appointed assistant general superintendent of motive power with headquarters at Springfield, Mo.

GEORGE DURHAM, master mechanic of the Delaware, Lackawanna & Western at Scranton, Pa., has been appointed superintendent of motive power and cars of the Wheeling & Lake Erie with office

at Brewster, O. Mr. Durham was born on October 10, 1875, at Pineville, Ky., and was educated in the common schools of his native town and later at Kentucky University, Lexington, Ky. He then entered the service of the Louisville & Nashville as a special apprentice and later served consecutively as a machinist, locomotive fireman, engineman, traveling engineer and general foreman until February 1, 1907. He was

then appointed master mechanic of the Knoxville & Atlanta division with headquarters at Etowah, Tenn., remaining in that position until October 1, 1908, when he was made master mechanic of the same road at South Louisville, Ky. On April, 1911, he left that position and was appointed master mechanic of the Scranton, Bangor & Portland and the Syracuse & Utica divisions of the Delaware, Lackawanna & Western, which position he held until his appointment on September 15, 1916, as superintendent of motive power and cars of the Wheeling & Lake Erie.

#### MASTER MECHANICS AND ROAD FOREMEN OF ENGINES

J. A. BASINER has been appointed master mechanic of the Chicago, Aurora & DeKalb with headquarters at Aurora, Ill., to succeed William E. Jones.

B. W. BLUE, foreman mechanical department of the Louisville & Nashville at West Lexington, Ky., has been appointed acting assistant master mechanic at that point, succeeding R. E. McCuen, who has resigned to go into other business.

W. D. CHAFFEE, master mechanic of the New York Central at Watertown, N. Y., has been made master mechanic at Corning, N. Y., succeeding E. J. Snell, transferred.

A. E. DALES, district master mechanic of District 3, Manitoba division of the Canadian Pacific, at Brandon, has been appointed district master mechanic of District 4, Alberta division, at Edmonton, Alta., succeeding A. West, transferred.

A. K. GALLOWAY, whose appointment as general master mechanic of the northwest district of the Baltimore & Ohio and the Cincinnati, Hamilton & Dayton was announced in these columns last month, was born in St. Thomas, Ont., October 1, 1885. After completing a high school education, he entered the service of the Michigan Central in 1902 as a machinist apprentice. On completing his apprenticeship he remained in the service of that road until November 1, 1914, during this time being promoted to the position of roundhouse foreman and later to general foreman. He then left

the service of the Michigan Central to become assistant master mechanic of the Baltimore & Ohio at Baltimore, Md., in which capacity he served until July 1, 1915, then being appointed master mechanic at Baltimore. Here he remained until his recent appointment as general master mechanic, above noted.

C. H. NORTON, master mechanic of the Erie at Avon, N. Y., has been transferred as master mechanic to Susquehanna, Pa.

JOHN L. SMITH, JR., whose appointment as master mechanic of the Pittsburgh & Shawmut at Brookville, Pa., was announced in these columns last month, was born in England, August 19, 1881. He received a high school education in this country, on completing which he entered the service of the Buffalo, Rochester & Pittsburgh in June, 1898. After serving his apprenticeship with this road he left railway service to enter the employ of the Westinghouse Electric & Mfg. Co., where he remained for several years. He then re-entered railroad work as roundhouse foreman of the Baltimore & Ohio at Cleveland, Ohio, later leaving this road to enter the service of the Pittsburgh, Shawmut & Northern at St. Mary's, Pa. Early in 1912 he was appointed general roundhouse foreman of the Erie at Buffalo, N. Y., in which position he remained until his recent appointment as master mechanic of the Pittsburgh & Shawmut.

E. J. SNELL, master mechanic of the New York Central at Corning, N. Y., has been appointed master mechanic, with office at Watertown in place of W. D. Chaffee, who has been transferred.

F. G. WALLACE, general foreman of the Erie at Dunmore, Pa., has been appointed master mechanic at Avon, N. Y., succeeding C. H. Norton, who has been transferred.

A. WEST, district master mechanic of District 4, Alberta division of the Canadian Pacific, at Edmonton, has been appointed district master mechanic of District 3, Manitoba division with office at Brandon, Man., succeeding A. E. Dales, transferred.

W. T. WIECHERT has been appointed road foreman of engines on the Montana division of the Northern Pacific, with headquarters at Butte, Mont., succeeding William Dean, resigned.

#### CAR DEPARTMENT

R. KNORR, formerly foreman car department of the Erie at Hornell, N. Y., has been made foreman car department at Port Jervis, N. Y.

W. H. ORMAN has been appointed repair track foreman of the Canadian Pacific at Ogden, Alta., succeeding P. J. Siverton, transferred.

P. J. SIVERTON, repair track foreman of the Canadian Pacific at Ogden, Alta., has been appointed car foreman at Swift Current, Sask.

#### SHOP AND ENGINEHOUSE

H. A. AMY, locomotive foreman of the Canadian Pacific at Schreiber, Ont., has been appointed locomotive foreman at Cartier, Ont.

W. COOK, foreman boilermaker, National Transcontinental at Transcona, Man., has been appointed foreman boilermaker of the Grand Trunk Pacific at Edmonton, Alta.

R. S. DICKSON has been appointed locomotive foreman of the Canadian Pacific at Schreiber, Ont., succeeding H. A. Amy.

C. W. HINERMAN has been appointed assistant night roundhouse foreman of the Chesapeake & Ohio, at Clifton Forge, Va.

R. SUMMERVILLE has been appointed foreman boilermaker



G. Durham

of the National Transcontinental at Transcona, Man., succeeding W. Cook, who has been transferred to the Grand Trunk Pacific.

F. J. TOPKING, formerly roundhouse foreman of the Chesapeake & Ohio at Ronceverte, W. Va., has been appointed night roundhouse foreman at Clifton Forge, Va.

O. C. H. WATERMAN has been appointed enginehouse foreman of the Cleveland, Cincinnati, Chicago & St. Louis at Brightwood, Ind., succeeding J. D. Branden.

#### PURCHASING AND STOREKEEPING

H. B. AKIN, storekeeper of the Canadian Northern at Joliette, Que., has been appointed storekeeper of the Ontario division at Trenton, Ont., succeeding E. D. Toye, who has resigned on enlistment for military service in Europe.

HUGH GREENFIELD, who was recently appointed acting purchasing agent of the Duluth, Missabe & Northern, with headquarters at Duluth, Minn., succeeding Fred H. White, deceased, has been appointed purchasing agent.

FRANCIS J. O'CONNOR, who has just been appointed general storekeeper of the Chicago, Milwaukee & St. Paul, with office at Milwaukee, Wis., was born August 18, 1874, at El Paso, Ill. After an elementary education he took a course at Green Bay Business College, leaving there early in 1891. In May of this same year he obtained employment with the Chicago, Milwaukee & St. Paul as stenographer and clerk in the store department at Green Bay, Wis., which position he held until November, 1894. From November, 1894, to July, 1895, he was storekeeper with headquarters at the same place, being then appointed clerk and foreman in the general store department at Milwaukee, Wis. From February, 1901, to November, 1902, he was chief clerk to the master mechanic of the Milwaukee shops and from November, 1902, to May, 1904, he was signal inspector and assistant signal engineer. In May, 1904, he was appointed chief clerk to the superintendent of motive power and held this position until appointed to the office of general storekeeper September 15.



F. J. O'Connor

J. F. PRATT has been appointed general storekeeper of the Great Northern, with office at St. Paul, Minn., succeeding John Opheim, transferred.

N. V. PORTER, formerly chief clerk to the division storekeeper of the Wabash, with headquarters at Decatur, Ill., has been appointed division storekeeper on the line between Danville, Ill. and Toledo, Ohio, succeeding E. L. Ensel, resigned.

O. H. WOOD has been appointed assistant purchasing agent of the Great Northern, with headquarters at Seattle, Wash., succeeding C. L. Bankson, resigned.

#### OBITUARY

W. A. THOMAS, master mechanic, and R. D. POND, roundhouse foreman of the Virginian Railway at Victoria, Va., were killed in a derailment on that road near Alberta, Va., September 20, while riding on the locomotive.

## SUPPLY TRADE NOTES

B. H. Forsythe, formerly with the Hale & Kilborn Company, has entered the sales department of the Grip Nut Company, with offices in the McCormick building, Chicago, Ill.

A. T. Whiting, vice-president and secretary of the Whiting Foundry & Equipment Company, Harvey, Ill., died at his home in Chicago, September 12, after only a few days' illness.

George M. Judd has been elected secretary of the American Brake Shoe & Foundry Company, to succeed Henry C. Knox, resigned. Mr. Knox will remain as treasurer of the company.

Announcement has recently been made by the National Tube Company, Pittsburgh, Pa., of its plans for building a new plant at Gary, Ind., having a capacity of 500,000 tons a year.

Reuben C. Hallett, for many years active in railway supply circles, and for several years past connected with the Duntley Products Sales Company, Chicago, Ill., died at his home in Chicago, September 10.

Herman Voelker, assistant general foreman of the American Car & Foundry Company, has resigned to accept employment as general foreman of the wood car department of the Ralston Steel Car Company, Columbus, Ohio.

The Van Dorn Electric Tool Company, Cleveland, Ohio, has recently completed and moved into a new plant, which will make possible the doubling of the output of its line of portable electric tools. The buildings are of steel, brick and concrete construction, and are two and three stories in height.

H. E. Daniels, formerly western representative of the West Disinfecting Company, of New York City, has been appointed manager of the railroad and steamship department, with headquarters in the Railway Exchange, Chicago. Mr. Daniels was born in Boston, Mass., in 1873, where he received his early education and training. Upon graduating from school he took employment in the transportation department of the old Concord Railroad, now a part of the Southern division of the Boston & Maine. Later he entered the mechanical department of the New York, New Haven & Hartford as a fireman, and was later promoted to engineer. He was connected with this company nearly eight years, resigning to accept service with his present employer.



H. E. Daniels

The Magor Car Corporation, New York City, has been chartered in New York with a capital of 7,500 shares, 4,000 shares at \$100 each, and 3,500 shares of no par value. It purposes to carry on business with \$417,500. Its object is to furnish cars, railroad supplies, rails, structures, bridges, etc. The incorporators are Walter F. Purcell, George C. Carey, Bigelow Watts and O. Z. Whitehead.

To meet the growing demand for Armstrong tool holders a 50-ft. by 70-ft. steel and brick addition to its drop forging department is being built by the Armstrong Bros. Tool Company, Chicago. A new four-story building, 60 ft. by 130 ft., is also being erected. This is of reinforced concrete, fireproof

construction, and, in addition to providing a warehouse for finished stock, will house the shipping department and the offices.

D. R. McVay has been appointed railway sales representative of the Barrett Company, New York City, with headquarters at Cincinnati, Ohio.

W. E. Sharp has been elected president of the Grip Nut Company, Chicago, Ill., to succeed Edward R. Hibbard, who is retiring from business. Mr. Sharp began his railway career as an apprentice in the car department of the Erie in April, 1889. In October, 1892, he was promoted to the position of general foreman of the car and locomotive department of the same road, with headquarters at Chicago. He left this position in 1898 to accept service with the Armour Car Lines as assistant superintendent, and in April, 1901, he became superintendent of this line. In 1911 he resigned this position to enter the railway supply business, becoming vice-president of the Grip Nut Company, which office he continued to fill until his recent election to the presidency.



W. E. Sharp

Howard H. Hibbard has been elected vice-president of the Grip Nut Company, to succeed W. E. Sharp, who has been elected president of the company. Mr. Hibbard is the son of Edward R. Hibbard, who is retiring from the presidency of the company to make his home in California. Immediately on leaving school Howard H. Hibbard began his work in the company's plant at South Whitley, Ind. While employed here he has made a careful study of the details of the engineering and manufacturing of the devices which are handled by the company.



H. H. Hibbard

H. K. Ellyson has been appointed eastern representative of the railroad and steamship department of the West Disinfecting Company, making his headquarters at the home office, 12 East Forty-second street, New York City. Mr. Ellyson has been with this company for some time in various capacities.

The Union Metal Products Company, Chicago, has been granted sales rights to the grain tight car sill, which was described in the Railway Age Gazette, Mechanical Edition, February, 1914, page 81. This sill is in use on the Rock Island, Minneapolis & St. Louis, and the Denver & Rio Grande. A careful check on 4,000 cars equipped on the Rock Island, and which have been in service for 15 months, has shown that no claims for grain leakage have been paid,

whereas, a check of 3,000 cars not so equipped has shown that claims were paid on 50 per cent of that number.

Henry B. Denker, one of the founders of the St. Charles Car Company, now a part of the American Car & Foundry Company, died at St. Charles, Mo., on August 30, aged 77 years. Mr. Denker was a native of Germany and came to this country when 19 years of age. He served in the Union army as captain during the Civil War, and then assisted in establishing the car plant which afterward was merged with the larger concern. After the merger he was made district manager.

The Railway & Mine Supply Company and the Kincaid Foundry & Machine Company, newly incorporated, have opened joint offices in the McCormick building, Chicago, Ill.

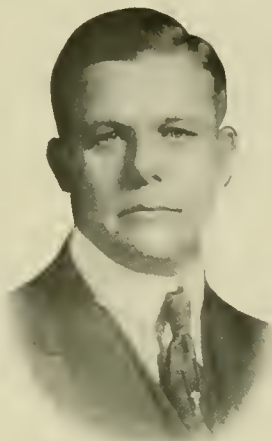

L. G. Binkley

The officers of the supply company are L. G. Binkley, president, and G. H. Peabody, vice-president; and of the foundry company, G. H. Peabody, president, and L. G. Binkley, vice-president. The Railway & Mine Supply Company will conduct a general jobbing business in railway and mine supplies. The Kincaid Foundry & Machine Company, which is the successor of the Hershfield & Piper Machine Company, formerly located at Taylorsville, Ill., is building a foundry at Kincaid, Ill. Kincaid is located on the Chicago & Illinois Midland about 90 miles from St. Louis, Mo. It is expected that the new foundry will be in operation some time in the month of December. The

company will do a general foundry business in both gray and chilled iron, specializing in all kinds of castings for the railroad and mine business. G. H. Peabody, president of the Kincaid Foundry & Machine Company, was born in New York City in 1883. For several years he was engaged in the brokerage business in Wall street, following which he went to Chicago to open the first western branch office of the Lima Locomotive Corporation.



G. H. Peabody

He remained there as western manager of that company until 1914, when he returned to New York to become manager of the benzol department of the Lackawanna Steel Company. A year later he joined the sales force of the Griffin Wheel Company at Chicago, and remained with that organization until recently, when he resigned to accept the presidency of the Kincaid Foundry & Machine Company. L. G. Binkley, president of the Railway & Mine Supply Company, was born at Marion, Ill., in 1882. In 1904 he entered the employ of the Egyptian Powder Company, Alton,

Ill., manufacturers of explosives for coal mining purposes. He remained with this company for 13 years, rising to the office of vice-president. He was also sales manager of the Equitable Powder Company, Alton, Ill., when he resigned from both positions on April 1, 1916, to promote the organization of the companies with which Mr. Peabody and he are now connected.

The Duntley Company, Fisher building, Chicago, has been made the sole western distributor for the Hudson Balata belting and other products of the Hudson Mechanical Rubber Company. The market for this class of belting has been materially increased on account of the war. Leather being in considerable demand by the warring nations has caused an increase in the price of leather belting of about 40 per cent.

W. D. Cloos, recently elected secretary and treasurer of the Lima Locomotive Corporation, Lima, Ohio, was born August 13, 1886, in Tioga County, Pa. After a preliminary education he entered Mansfield State Normal School, taking a four-year course from 1903 to 1907. Later he attended Mississippi State College, leaving in 1908. He was connected with the Franklin Railway Supply Company, Franklin, Pa., until his present appointment became effective.

Charles D. Ettinger, for 45 years connected with the Murphy Varnish Company and president of the Ohio Injector Company of Chicago, died September 4, after a brief illness.

Mr. Ettinger was born at Wadsworth, Ohio, June 20, 1838, and during the civil war served in the hospital division of the quartermaster's department. After the war he engaged in the drug business in Findlay, Ohio. In 1871 he moved to Cleveland and took charge of the railroad department of the Murphy Varnish Company, removing to Chicago in January, 1884. Mr. Ettinger was secretary of this company and one of its directors. He partially retired from the activities of business a number of years ago, spending the greater part of his time in developing his farm at Midlothian, Ill.



Charles D. Ettinger

R. W. Cameron & Co., New York, who maintain a staff of engineers in Australia and New Zealand in connection with their export business, have found it necessary to recall R. W. Nichols of their Australian staff to New York in order to cope with the increasing business in railway supplies, machine tools, steel products, etc., and will have the advantage of the services of an engineer who thoroughly understands conditions in Australasia as well as the United States and Canada.

A new company has been formed with a capital of \$400,000 to take over the defunct Nova Scotia Car Works, which were recently sold at auction for \$157,000. The shareholders of the old company have been called to meet in Halifax, when it is expected that a new company will be organized with F. T. Curdy, M. P., as president. The proposal for raising funds is that old shareholders be given the opportunity of one share of stock in the new company for every six shares held in the old concern.

Louis Sears has been appointed manager of railway sales of the Willard Storage Battery Company, Cleveland, Ohio, succeeding the late W. E. Ballantine. Mr. Sears has been with the Willard Storage Battery Company since April, 1908, remaining at the factory until January, 1910, at which time he went to the Chicago office where he remained until October, 1913. He was in the Cleveland office October, 1913, to March, 1915, and from March, 1915, to August, 1916, he was located in the New York office. Mr. Sears was transferred to the Cleveland office and received the appointment to his present position of manager of railway sales on August 1, 1916.

W. E. Greenwood has been appointed assistant manager of the railway sales department of the Texas Company, with headquarters at New York. Mr. Greenwood was born in New Orleans, La., and received his education at Roanoke College, Salem, Va. He entered railroad service in 1894 as clerk in the purchasing department of the Terminal Railroad Association of St. Louis. He left there January, 1898, to accept service in the purchasing department of the Missouri, Kansas & Texas at St. Louis, Mo., as voucher clerk, becoming chief clerk in 1901. He left railway service in April, 1912, to accept the position of eastern representative of the railway sales department of the Texas Company, where he remained until his recent appointment as assistant manager of the railway sales department.



W. E. Greenwood

The board of directors of the Lima Locomotive Corporation, Lima, Ohio, has elected W. E. Woodard vice-president, in charge of engineering and design, with offices at Lima, Ohio. Mr. Woodard was born in Utica, N. Y., in 1874, and attended the public schools at that place. He was graduated from Cornell University with the degree of mechanical engineer in 1896. For a time he was engaged in the laboratory and on road tests for the Baldwin Locomotive Works, but in 1897 entered the shop and drawing office of the Dickson Locomotive Works as elevation man. In 1900 he went with the Schenectady Locomotive Works, remaining with it and the American Locomotive Company, which succeeded it, up to the time of his present appointment. While with the American Locomotive Company he was employed in various capacities, including calculator, chief calculator, road testing work, foreman drawing office, assistant mechanical engineer, manager electric loco-



W. E. Woodard

motive and truck department, and finally as assistant chief engineer, having supervision over the general drawing office at Schenectady, N. Y. Mr. Woodard has patented a number of devices which are extensively used on modern heavy car and locomotive equipment, including the lateral motion driving box and axle, constant resistance engine truck, throttle pipe and lever, plate frame car trucks, car body height adjuster, lateral motion bolster and car and tender trucks. He is a member of the American Society of Mechanical Engineers and the Engineers of Eastern New York.

Edward Cumberland Fisher, formerly assistant manager of the Cooke and Rogers works of the American Locomotive Company, has been appointed manager of the Cooke works

of that company at Paterson, N. J. He was born May 2, 1875, on a farm in Virginia. At the age of sixteen he entered the Virginia Mechanics' Institute, a night school of technology in Richmond, and at the same time entered the shops of the Tidewater & Western Railroad at Chester, Va., as a machinist apprentice. Shortly after completing his apprenticeship he accepted the position of general foreman of the Petersburg Iron



Edward C. Fisher

Works. When the firm failed about a year later he entered the employ of the Southern Railroad in its shops at Spencer, N. C., where he was soon made gang foreman. The following year he returned to Richmond as foreman of outside construction for the Richmond Iron Works, and shortly after was appointed instructor of mechanical drawing for the Chesapeake & Ohio in its apprentice school at Huntington, W. Va. This position he held until November 1, 1899, at which time he returned to Richmond as foreman for the Richmond Locomotive Works. After serving in various capacities, both in the drawing office and shops, he was transferred June 15, 1910, to Paterson, N. J., as superintendent of the Rogers works of the American Locomotive Company. In June, 1913, he was appointed assistant manager of the Cooke and Rogers works, and has now been appointed manager of the Cooke Works, as above noted.

The Edison Storage Battery Supply Company, Orange, N. J., announces the opening of its Los Angeles office on the fourth floor of the San Fernando building, corner Fourth and Main streets. James F. Rogan, who has been acting as local distributor of Edison storage batteries in Los Angeles, will become resident manager. This company also maintains two other offices on the Pacific Coast, one at 206 First street, San Francisco, in charge of District Manager E. M. Cutting, and another at 65 Columbia street, Seattle, under F. C. Gibson as resident manager.

D. E. Cain, western manager of the Dearborn Chemical Works, whose death at Denver, Colo., was recently announced, was born September, 1862, in Chicago, Ill., where he received his early education. He first entered the service of the Chicago & North Western, and in 1881 became connected with the Atchison, Topeka & Santa Fe as cashier at Osage City, Kan. From that time to July, 1902, he was consecutively on this same road as agent at Osage City and Leavenworth, Kan.; chief clerk to general superintendent of machinery at Topeka, Kan.; chief clerk to general manager,

and assistant to general manager. From July, 1902, to April, 1905, he was general superintendent of the western grand division of the same road, with office at La Junta, Colo., and from April to June, 1905, he was general superintendent of the eastern grand division, with headquarters at Topeka, Kan. In June, 1905, he was appointed general manager of the Southwestern & Choctaw districts of the Chicago, Rock Island & Pacific, with office at Topeka, Kan., from which position he resigned in December, 1906, at the time that the Southwestern & Choctaw districts were placed under the jurisdiction of one general manager. He then became western manager of the Dearborn Chemical Works, having his headquarters at Denver, Colo. He was identified with this concern up to two years ago when ill health overtook him, and he found it necessary to retire from active business. He died in Chicago, the city of his birth, on August 31, 1916.

The Railway Motor Car Company of America, Chicago, Ill., has acquired a 13-acre plant at Hammond, Ind., fully equipped, in which it will at once begin the manufacture of cars. These cars will be made under patents owned by the company, and will be different in transmission and construction from any cars now in use. It is stated that the section car will constitute a self-contained power plant available for all sorts of track repairs. Later the company will produce unit passenger cars and locomotives, using the same principle of construction. F. A. Lester is vice-president and sales manager, and will have his headquarters in the Westminster building, Chicago, Ill.

Burton W. Mudge, president of Mudge & Co., Chicago, dealers in railway specialties, has also been elected president of the Safety First Manufacturing Company, Chicago, which

will handle in western territory the asbestos and magnesia products of the Franklin Manufacturing Company, Franklin, Pa., together with additional specialties. Mr. Mudge was formerly connected with the operating departments of the Atchison, Topeka & Santa Fe, the Chicago & North Western, the Fort Worth & Denver and the Chicago, Rock Island & Pacific, from which latter road he resigned as assistant to the general manager in 1908 to engage in



B. W. Mudge

the railway supply business. In September, 1908, he started the firm of Burton W. Mudge & Brother, representing the Commonwealth Steel Company, of St. Louis, Mo. Later the company name was changed to Burton W. Mudge & Co., and finally to Mudge & Co. The specialties to be handled by the Safety First Manufacturing Company under the direction of Mr. Mudge include a parcel rack for passenger cars, a caboose stove, angle cock brackets for freight cars and a combustion chamber for oil burning shop furnaces.

E. R. Rayburn, manager of the Chicago office of the Franklin Manufacturing Company will still continue to handle all of its waste packing products as heretofore, throughout the entire western part of the United States. The items to be handled by the Safety First Manufacturing Company, in connection with its association with the Franklin Manufacturing Company, will be their magnesia and asbestos lines, and the territory covered by such sales as made will

pass along the western boundaries of Minnesota, Iowa, Missouri and Arkansas, and run from the northwestern corner of Louisiana through New Orleans.

The Pollak Steel Company, manufacturers of car and locomotive axles, with plant located at Cincinnati, Ohio, announces that it has taken over the Willard Sons & Bell Company of South Chicago, Ill., and will make axles there as well as in Cincinnati. The capacity of the plant at Cincinnati recently has been doubled and extensive improvements have been made in it in the way of additional buildings and new machinery. About 1,500 men are now employed at this plant and about 500 men at the South Chicago plant. The combined forging and axle output of the two plants is estimated at 30,000 tons per month. Rodney D. Day, formerly general manager of sales for the William Tod Company, Youngstown, Ohio, has been appointed assistant to the vice-president of the company, with headquarters at Cincinnati. Mr. Day will be in full charge of all operations of both plants. Frank Dunbar, formerly western sales manager of Brown & Co., of Pittsburgh, Pa., and for many years connected with the mechanical department of the Missouri Pacific, has been appointed district manager with headquarters at South Chicago.

Frank Taylor Hyndman, superintendent of motive power and cars of the Wheeling & Lake Erie, has been appointed general manager of the Damascus Brake Beam Company, with office at Cleveland, Ohio, effective August 1, 1916, with full charge of plant operation and production. He was born on September 29, 1858, and began railway work in 1872 as machinist apprentice on the Central of New Jersey at Ashley, Pa., and from 1874 to 1877 was an apprentice in the shops of the Lehigh Valley at Wilkes-Barre; then, for about three years, was brakeman and fireman on the Central of New Jersey. From March



F. T. Hyndman

to November, 1880, he was a machinist on the Atchison, Topeka & Santa Fe at Raton, New Mexico, and from March, 1881, to August, 1883, was machinist on the Pittsburgh & Western and with the Pittsburgh Locomotive Works, becoming an engineman on the Pittsburgh & Western in August, 1883. He remained in that position until September, 1895, when he was made trainmaster, and from April, 1896, to November, 1902, was master mechanic of the same road at Allegheny. He was then, for one month, master mechanic on the Baltimore & Ohio at Pittsburgh, and from December, 1902, to July, 1904, was master mechanic on the Buffalo, Rochester & Pittsburgh. In July, 1904, he was appointed superintendent of motive power of the same road at Dubois, Pa., and the following November went to the New York, New Haven & Hartford as general master mechanic at New Haven, Conn. He became mechanical superintendent of that road in May, 1906, resigning from that position on July 15, 1907, to enter the railway supply business. He was the Philadelphia representative of S. F. Bowser & Co., Inc., Fort Wayne, Ind., in July, 1913, when he was appointed superintendent of motive power and cars of the Wheeling & Lake Erie, which position he held until he was appointed general manager of the Damascus Brake Beam Company on August 1, as above noted.

## CATALOGUES

**OVERHEAD CARRYING DEVICES.**—The New Jersey Foundry & Machine Company, New York, in catalogue 88, gives illustrations, descriptions, capacities and price lists of its line of overhead carrying devices. There are included tracking, trolleys, hoists, cranes, buckets, cars, etc.

**DRILLS AND REAMERS.**—Catalogue No. 15, issued by the Celfor Tool Company, Buchanan, Mich., is a 90-page book in which is listed the complete line of standard drills and reamers manufactured by this company. The catalogue also contains a list of drill chucks, drill sockets, lathe tool holders, tool bits, flue cutters and drill gages.

**LOCOMOTIVE TANKS.**—The Locomotive Tank Company, New York, has issued a folder descriptive of the Acme-Flanged sectional locomotive tank. The distinguishing feature of the tank is that the top and bottom are formed from plates with edges turned toward the water space, thus eliminating all rivet holes through top and bottom.

**MAKING DAVIS WHEELS.**—The American Steel Foundries have just issued an attractive 24-page booklet bearing the above title. In substance it describes a trip through the plant, viewing the processes of work on car wheels from the raw materials to the finished product. The pamphlet is not only interesting and informative, but is well printed, the illustrations being especially interesting.

**MULTIBLADE FANS.**—The Clarage Fan Company, Kalamazoo, Mich., has recently issued catalogue No. 5, setting forth its line of multiblade fans for heating, ventilating and exhaust purposes. This is a 24-page booklet contained in a mailing folder; it is well illustrated and contains a number of capacity tables for the various size units. A more complete catalogue, No. 51, will be sent on request.

**BULB SECTIONS.**—Under date of September 1, the Carnegie Steel Company, Pittsburgh, Pa., has issued a third edition of "Bulb Sections," a 17-page pamphlet, in which are catalogued the bulb angle and beam section, limited quantities of which are used in the car and shipbuilding trades. These sections are not carried in stock, but are furnished on order. The usual data concerning the dimensions and properties of the sections are given.

**PASSENGER CAR TRIMMINGS.**—Catalogue No. 200 recently issued by the Dayton Manufacturing Company, Dayton, Ohio, is 9 in. by 12 in. in size and contains 1,600 pages of illustrations of passenger car trimmings of all kinds. The book is a complete catalogue of passenger car hardware, lighting fixtures, water and dry closets, washstands and saloon fittings, vestibule and platform trimmings, brake handles, sash fixtures, basket racks, headlights, etc.

**TRAIN LIGHTING BATTERIES.**—Bulletin 118, recently issued by the Edison Storage Battery Company, Orange, N. J., bears the title, Train Lighting Batteries, Edison. The booklet defines the various points of superiority of the Edison alkaline storage battery, touching upon its advantages under the heads of weight, maintenance and operation, life, temperature, efficiency and care. Several pages in the bulletin are devoted to a description of its manufacture.

**FOUNDRY EQUIPMENT AND APPLIANCES.**—"A Model Foundry" is the title of booklet No. 125, which has recently been issued by the Whiting Foundry Equipment Company, Harvey, Ill. This gives in a general way the methods followed by this company in designing, equipping and conducting the initial operation of complete foundry plants for the manufacture of grey iron, brass, car wheel, pipe, converter steel and malleable castings. The book contains 36 pages and is profusely illustrated with photographs both of equipment details and various installations made by the Whiting Foundry Equipment Company.

# Railway Mechanical Engineer

Volume 90

November, 1916

No. 11

## Our Prize Competitions

The number of papers received in the competition on hot boxes on freight cars was so large that the judges have been unable to come to a decision as to the winners in time for publication in this issue. The papers are said to discuss the subject from widely different viewpoints and therefore promise to be of exceptional interest and practical value. The closing date for the competition on the benefits received from convention attendance was still two days off when we closed our forms, but the number of contributions received up to that time indicated an interest which, we hope, will mean much for the strengthening and enlarging of mechanical department associations. The educational value of these organizations is undoubtedly responsible for much of the rapid progress which has been made in the motive power and car departments during recent years.

## Higher Officers, Attention!

Do you know what the Chief Interchange Car Inspectors' and Car Foremen's Association is doing? Do you realize the importance of its work? Are you aware of the fact that it is a most important adjunct to the M. C. B. Association? If you do, why not show your appreciation and interest by attending one of the sessions of its annual convention? The inspiration it will give the members will well repay your road in dollars and cents. The presence of such men as F. W. Brazier, W. O. Thompson and A. LaMar at the Indianapolis convention last month was deeply appreciated by the officers of the association and every member in attendance. Many other of the higher mechanical and operating officers, particularly in the section of the country in which the meeting was held, might easily have made it possible to attend if they had realized the effect their presence would have. This is true also of the other mechanical department associations. It is poor policy for any officer to so busy himself with details that he cannot find time to keep in intimate touch with his subordinates. Here lies his greatest opportunity for producing results, and yet how many seem to overlook it. Lending a hand and helping to inspire those in attendance at the minor railway mechanical department conventions is one means of attaining this end and is sure to bring results.

## The Value of the Shop Band

Asked what had been the most important development within the past year at a large railroad shop with which he was connected, the shop foreman replied without hesitation: "The starting of our shop band. It seems to have stirred our fellows up to a higher degree of loyalty. It has developed a number of boosters who are in no way connected with the band. The fellows are taking a greater pride in being connected with the shop and the road, and I imagine I can see more team work among our men as individuals and between the various departments of the shops." This is pretty strong testimony. It is hard, how-

ever, to discount the effect of seven bands at the big Erie celebration and field meet at Huntington, Ind., last August; or of the presence of half a dozen or more bands at the annual outdoor athletic meet of the Pennsylvania Railway at Altoona, Pa., on September 30, when the Altoona car shop base ball team beat Philadelphia Terminal before a crowd of 21,000 or more, thus winning the system championship; or of thousands of boosters from all over the Missouri, Kansas & Texas who were inspired by several shop bands at the big field meet at Parsons, Kan., on October 7, when the Sedalia, Mo., ball team won the system championship by beating Smithville, Tex. A good band, or even a very ordinary one, is one of the little things that will do much to build up the greatly to be desired spirit of enthusiasm and loyalty in an organization.

## The Two Convention Stories

The reports of the conventions of the Traveling Engineers' Association and the Chief Interchange Car Inspectors' and Car Foremen's Association, which will be found elsewhere in this issue, cover only the proceedings of the first half of these two important meetings. The remainder of the proceedings of both conventions will be reported in our December issue. Two reasons are responsible for this deviation from our usual practice. To cover fully the Traveling Engineers' meeting, which was held during the last week of October, it would have been necessary to delay the publication of this number. Then, too, we have found it advisable to carefully study the balance of each number. By "balance" we mean that each issue is carefully designed to present such a variety of material as to meet the needs of each of the various classes of men who are numbered among our readers. We could only include complete reports of these two meetings by crowding out other material of special interest and value to those who may not be particularly interested in either one of these two conventions. In the case of the Chief Interchange Car Inspectors' and Car Foremen's Association we have included a running report of the convention with abstracts of the special addresses which were made, and an account of the discussion of the Rules of Interchange. This leaves for consideration in the next issue the prize stories on car department apprenticeship, and the several individual and committee reports which are an entirely new feature in the work of this organization.

## Loss and Damage to Freight

Defective freight car equipment is responsible for a considerable percentage of the loss and damage to freight, both directly and indirectly through pilferage and wrecks. Great strides have been made in reducing this loss in recent years, a series of articles on Defective Box Cars and Damaged Freight in the Railway Age Gazette, during April and May, 1912, being an important factor in

awakening railway officers to the true situation. Much still remains to be done in making further reductions. Car inspectors especially are in a position to see and study conditions which are responsible for these losses. If you find a cause of loss or damage and make a practical suggestion to remedy the difficulty, do not become disheartened and disgusted if your suggestion is not immediately acted upon. Keep right after the wrong condition, if it is of sufficient importance, until something is done to remedy it. A wise college professor used to tell his boys that if they were fighting in a good cause, to keep pegging away until they made an impression. "If you were to throw a handful of mud at a highly polished marble wall," he said, "it would not make much, if any, impression; only a small and insignificant portion might stick. But if you keep on, gradually more and more will stick until you finally cover the entire wall." A real executive officer cannot but admire a subordinate who will not be satisfied until he has put a good thing over, or if he is wrong, keeps at it until he is shown to be in the wrong.

#### The Eight-Hour Day Question

Several weeks have now elapsed since Congress at the request of President Wilson, and to avert a nation-wide strike of the men in railway train service, hurriedly passed the Adamson law. This law purports to be one to establish an eight-hour day in train service, but its language clearly shows that this is not its purpose or effect. It provides that "eight hours shall, in contracts for labor and service, be deemed a day's work, and the measure or standard of a day's work, for the purpose of reckoning the compensation of all employees who are engaged in any capacity in the operation of trains." This says, as expressly as it could be said, that eight hours is to be considered a day's work for only one purpose, and that is for the reckoning of compensation. Elsewhere the act provides that overtime after eight hours shall be paid pro rata, thus showing that it is contemplated that employees in train service shall continue to work more than eight hours. A commission to observe the workings of the law for six to nine months is created, and the same wages must be paid for eight hours as are now paid for ten hours until 30 days after this commission makes its report. The investigating committee recently appointed is of excellent personnel, being composed of General Goethals, the builder of the Panama Canal, George Rublee, who is a member of the Federal Trade Commission, and E. E. Clark, who is a member of the Interstate Commerce Commission.

Enough time has now passed since the Adamson law was enacted for sober reflection as to the significance of its enactment. It is well known that it was rushed through Congress chiefly to prevent the strike that was threatened. Nothing could be plainer than the fact that it does not establish an eight-hour day, but merely grants an increase of 25 per cent in wages to the class of railway employees who are the best paid already. It ignores the rights, the welfare, and even the existence of the other 80 per cent of railway employees. By forcing upon the railways an increase in the wages of the train service employees it necessarily renders it more difficult for the railway managements to make any concessions that they might otherwise have been able and willing to make to the rest of their employees, and to officers of those ranks who are directly in contact with the employees, such as shop foremen, road foremen of engines, master mechanics, etc. The Chamber of Commerce of the United States advocated the passage of a resolution by Congress providing for an investigation by the Interstate Commerce Commission of the conditions of work and wages of all railway employees, but this plan President Wilson and Congress unceremoniously threw into the discard.

The disregard of the rights and the welfare of a large

majority of railway employees and of the public shown by the train service employees in threatening to tie up the transportation and commerce of the entire country, and by President Wilson and Congress in passing the Adamson law, are but too apparent. The labor brotherhoods are now openly seeking votes for President Wilson because of the course he took in connection with this matter. He certainly did not give the other employees of the railways any reason for feeling kindly or grateful to him.

#### Selection of Future Officers

Those who read the paper presented by F. W. Thomas, supervisor of apprentices of the Santa Fe before the October meeting of the New York Railroad Club, an abstract of which is printed elsewhere in this issue, will be impressed with the simple logic of not leaving to chance the selection and training of men who are eventually to occupy positions of more than ordinary responsibility. It is difficult to understand why more thought has not been given to this particular phase of the training of men. Judging from the methods usually employed, the theory seems to be that from the ranks there will automatically arise enough men of exceptional ability to fill the positions of responsibility as the needs arise. From the selection of men for the ranks upward, the entire problem is, therefore, left to chance. That this is very poor policy is proved by the frequency with which we see organizations forced to go outside their own ranks for officers, and especially in the mechanical department by the frequency with which the question is asked "What is the matter with the mechanical department?"

It is evident that if leaders are to be selected from the ranks, the right kind of men must be brought into the service at the bottom. But the solution of this problem alone does not necessarily insure the best results in the promotion of men. Leaving this to chance will often result in costly failures, which could have been avoided had a careful selection of the available material been made well in advance of the actual requirements. The selection from the ranks of recruits for promotion and the special training which is offered to them by the Santa Fe augurs well for the breadth of vision of its future mechanical department officers. Furthermore it serves a very important function which should not be overlooked. Mr. Thomas states that over 80 per cent of the men selected for the severe special course training, stick it through to the end. Presumably every man selected for this course is supposed to possess the qualifications necessary to meet future responsibility. Is it not far better to eliminate the 20 per cent who, for various reasons, give up under the strain of this training, before rather than after the effectiveness of the organization is seriously impaired by their failure?

#### Uniform Interpretation of Interchange Rules

One need only attend a meeting of the Master Car Builders' Association when the members are discussing the rules of interchange to realize the many complications that may arise in the application of these rules. And, by the way, the discussion of the rules by the members of the Chief Interchange Car Inspectors' and Car Foremen's Association does not suffer in comparison with similar discussion by members of the Master Car Builders' Association. It is quite apparent that these men are more familiar with the actual details of the work than are the men at the head of the mechanical department.

Will there ever be a strictly uniform interpretation of the application of the rules? Possibly, but a layman must necessarily be a little skeptical after listening to the discussion of the rules and the opinions expressed by what may be considered the cream of the car interchange inspector's profession. At any rate, it is readily apparent that the use of cheap men or the lack of training and educational work



among the inspectors is liable to prove a most costly practice on the part of any road which does not give studious and constant attention to these things.

Several contributors to the competition which the *Railway Mechanical Engineer* held last year on the qualifications and training of car inspectors emphasized the fact that they should have a fair understanding of the use of English and at least a common school education. Apparently they might have insisted on even more exacting requirements in this respect. It is surprising what the misunderstanding of the use of even a comma may cost a company in the misapplication of at least one of the rules. It may be advisable in the interests of a more uniform interpretation of the rules to give greater attention to the simplest possible wording of the rules, amplifying in some cases by the introduction of short sentences or explanations in parentheses, rather than to depend too greatly on the right understanding of a compound sentence by a man of comparatively limited education and practically no technical training. At any rate, it is beyond question that plentiful returns will follow any investment which will train and develop the inspectors and car foremen to a better understanding of the rules and regulations with which they must be familiar. Misinterpretation of the rules is liable to prove a very expensive proposition.

**Car Department  
Apprentice  
Problem**

Something is surely wrong when a car department officer will admit that desirable young men cannot be attracted to the car department because of lack

of opportunity for advancement in that department. The following figures are for the year ended June 30, 1916, and include the larger roads which were first to issue annual reports for that period. It will be seen that with the exception of the Santa Fe and Southern Pacific the expenditures for repairs to freight and passenger cars are in all cases higher, and in some cases very much higher, than the cost of repairs to steam locomotives. Figures for repairs to freight and passenger cars do not include work equipment or repairs to electrical equipment on cars.

Road	Repairs to Steam Locos.	Repairs to Freight and Passenger Cars.
Atchison, Topeka & Santa Fe.....	\$8,184,483	\$5,908,818
Buffalo, Rochester & Pittsburgh.....	708,462	1,319,551
Chesapeake & Ohio.....	2,721,998	4,966,258
Chicago & North Western.....	4,700,785	6,118,310
Chicago, Milwaukee & St. Paul.....	5,809,104	7,491,970
Chicago, St. Paul, Minn. & Omaha.....	865,320	869,684
Lehigh Valley.....	3,039,037	3,135,789
Missouri Pacific.....	3,726,486	7,987,302
Norfolk & Western.....	3,189,180	3,851,418
Southern Pacific.....	3,280,565	2,596,367
Southern Railway.....	3,567,659	4,689,860

Confirming these figures we find that the Interstate Commerce Commission's statistics for the year ended June 30, 1914, show expenditures of \$175,108,236 for repairs to steam locomotives on the part of those roads having a revenue of more than \$1,000,000 a year. The repairs to freight and passenger cars for the same period amounted to \$214,689,943, or 22 per cent more than for repairs to steam locomotives.

There are just as great—probably far greater—possibilities for savings in the car as in the locomotive department. Why is it not more important to devise means whereby capable and desirable young men will be attracted to and held in that department? If conditions are not such as to do this now, then they should be changed, and changed quickly. The secret of efficient operation of any department of a railroad is in its men, and no effort or expense is too great that will raise the level of ability and loyalty of the men. If your superior officer does not recognize this, then it is up to you to present facts and arguments to bring him to a full realization of its importance. You dare not sidestep your responsibility in this matter. Car department officers have too long held up their hands and tried to excuse themselves for the

conditions which now exist. The importance of the problem is too great to permit of any excuses. Get busy and do your part in making conditions what they should be.

**A Weak Spot  
in Shop  
Management**

Not a few of our railroad shop superintendents and mechanical department officers are due for a severe jolt one of these days. At a time when it is absolutely necessary to use every effort to operate all departments of a railroad efficiently and economically, supervising officers must see to it that no reasonable opportunity is overlooked for making improvement. The introduction of shop schedules has done wonders in a large number of shops in which it has been given a fair trial. We have advocated the use of such schedules for 12 or 15 years and from time to time have explained their application in detail, and have called attention to the concrete benefits which have resulted from their use. For some reason—probably lack of initiative on the part of those in charge—the practice is not by any means general at this late date.

There may be some excuse, although it is doubtful, for the officer who cannot awake to the necessity for introducing modern apprenticeship methods. There is less excuse for the officer who does not realize the value of improving working conditions so that the individual may achieve his highest efficiency. A man to fully appreciate these things must be a real executive and must be able to clearly see into the future. There is, however, absolutely no excuse for the officer who cannot see the concrete and practical value of the shop schedule system. It is not an easy matter to install such a system, but little difficulty is experienced after it is once fully established; in fact it eliminates a great deal of friction and lost motion and greatly simplifies the problem of shop management. A most complete discussion of the details of a successful scheduling system, and its benefits, was presented by Henry Gardner at the 1913 meeting of the International Railway General Foremen's Association (*Railway Age Gazette, Mechanical Edition*, October, 1913, page 423). Briefly such a system will increase the shop output, reduce the unit costs and keep the locomotives out of service a minimum amount of time. The work of the various departments is equalized; friction is reduced; the men know exactly when their work on a given engine must be completed and are better satisfied, whether working on a day work or piece work basis; the foreman's work is simplified and he is able to give more time to the larger problems of his department.

**NEW BOOKS**

*Coal, Its Economical and Smokeless Combustion.* By J. F. Cosgrove. Bound in cloth. 273 pages, 5½ in. by 8½ in. Published by the Technical Book Publishing Company, Philadelphia, Pa. Price \$3.

The purpose of the author has been to provide a comprehensive text book on coal for the use of engineers, smoke and fuel inspectors, purchasing agents and all who have to do with the combustion of coal in power plants, locomotives, etc., the entire subject being treated in simple, non-technical language. The book includes in a single volume a large amount of information which, although much of it has previously been available, has been widely scattered and therefore of but little general use. It first takes up the subject of coal, its classification, characteristics and composition, dealing briefly with its geological history and the distribution in the United States. Chapters are also included on the analysis of coal, the determination of its heating value and the purchasing of coal. The remainder of the volume is devoted to various questions relative to combustion, including a discussion of clinkering and its prevention and smokeless firing.

The text is supplemented by over 30 tables and a number of illustrations. In the appendix is given a table showing the analysis of 319 American coals.

# BRITISH EXPRESS LOCOMOTIVES

Examples of High Speed Passenger Engines Showing the Tendencies of Modern British Practice

BY E. C. POULTNEY, A. M. I. M. E.

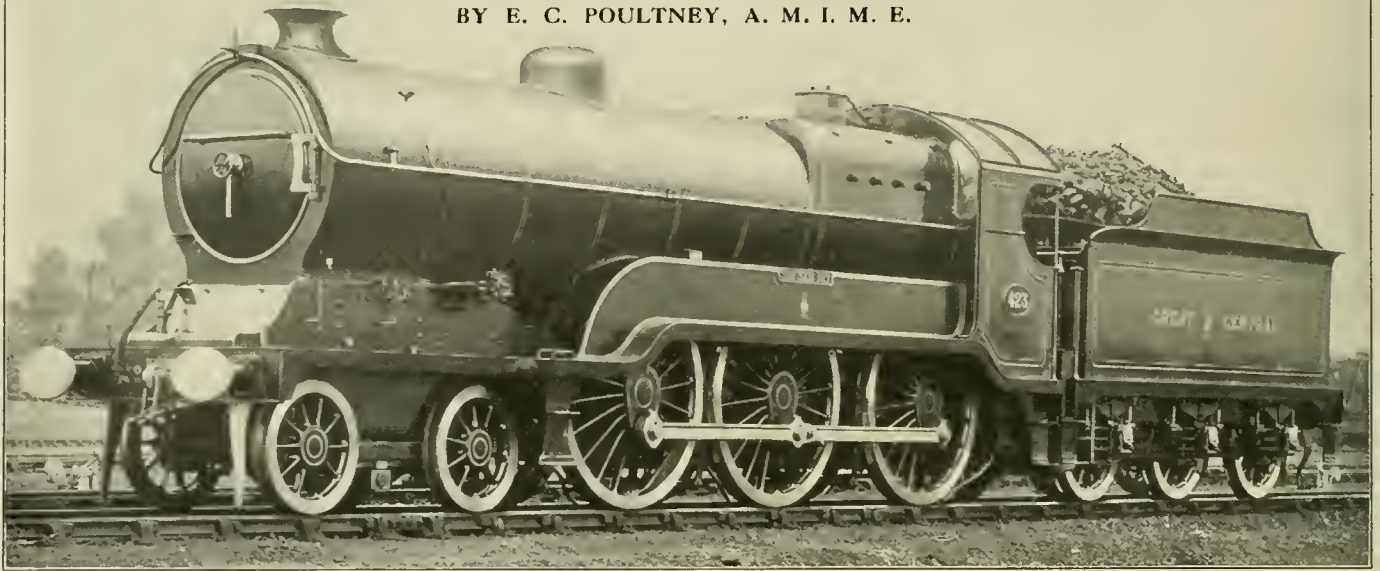

Great Central Six-Coupled, Two-Cylinder Superheater Locomotive

BEFORE entering upon a delineation of some notable examples of express locomotives in use on the principal British railways, which is the purpose of this article, it may be profitable to consider the various types in operation from a comparative standpoint and also to point out the general characteristic features of British locomotive practice.

The table of dimensions and proportions accompanying this article gives the principal types which find favor at the present time, together with the leading dimensions of the engines selected for treatment. By far the most favored engines in use are still the four-coupled type with leading bogie, having, as a rule, inside cylinders; but the reasons

the present time. In Britain engines capable of maintaining about 1,500 i.hp. will do all that is required in express service and boilers large enough to produce this power can be carried on ten wheels, hence the Pacific type so largely used in the United States has not passed the experimental stage. The 4-4-2 type naturally received consideration when the general introduction of vestibuled corridor stock increased the demands made on the locomotive, and the first engines of this type with outside cylinders were introduced on the Great Northern Railway for running the Anglo-Scottish expresses. These engines were comparatively small and did not possess boiler power greater than could have been obtained by the use of 4-4-0 engines. However, later much larger engines

TABLE I—COMPARISON OF EXPRESS LOCOMOTIVE BOILERS, SHOWING ALTERATIONS IN THE HEATING SURFACES AND EVAPORATIVE POWER DUE TO THE INTRODUCTION OF FIRE TUBE SUPERHEATERS

Railway	Type	Heating surfaces				1 Reduction in tube surface due to superheater, per cent	2 Reduction in evaporative power of boiler, per cent	3 Superheating surface, per cent of tube surface
		Tubes	Firebox	Total	Superheater			
Caledonian	4-6-0	2,111.75	148.25	2,260				
		1,666.0	148.25	1,818.25	515	21.0	14.2	23.7
London & North Western	4-6-0	1,857	133.00	1,990.00				
		1,439.59	133.33	1,572.92	324.58	22.5	11.05	18.4
Great Western	4-6-0	1,989	154.0	2,143.0				
		1,687	154.8	2,241	330	15.2	9.84	16.4
London & North Western	4-4-0	1,800.25	161.75	1,962.0				
		1,385.0	161.75	1,547	362.5	28.6	10.75	17.9
North Eastern	4-4-2	2,160	180	2,340				
		1,798.9	180	1,979	530	16.7	13.62	22.7
Great Northern	4-4-2	2,359	141	2,500				
		1,884	143	2,027	570	20.5	13.92	23.2
Midland, compound (superheated)	4-4-0	1,305.5	152.8	1,458.3				
		1,170.0	151.0	1,321.0	360	10.3	14.12	23.5

Note: The above particulars are taken from boilers which have been rebuilt with superheaters of the Schmidt type for high degree superheat, except in the case of the Great Western, which, as will be seen, uses smaller superheaters, due to the fact that the practice on this railway is to use a low degree of superheat.

which, in the United States, have caused engines with this wheel arrangement to be superseded successively by the Atlantic, six-coupled bogie and Pacific types have, in England, caused designers to turn to these different types. With the exception of the Pacific type, of which there is as yet only one example at work, namely, "The Great Bear" of the Great Western Railway, these types are all to be found in use at

have been introduced for this service having boilers with 2,500 sq. ft. of heating surface and wide fireboxes giving 30 sq. ft. of grate area.

The North Eastern Railway, under the direction of the late chief mechanical engineer, W. Worsdell, was the first railway to introduce six-coupled locomotives for express service; here again the first engines were comparatively small, but

later engines were given larger boilers and the driving wheels were increased in size from 73 in. to 80 in. diameter. In both classes the cylinders were placed outside the frames and drove on the second coupled axle. These engines have now, however, given place to large 4-4-2 engines, the first of which type were, at the time of their introduction, among the largest engines in Britain, having outside cylinders 20 in. in diameter with a stroke of 28 in., boilers with approximately 2,500 sq. ft. of heating surface and weighing without tender 73 tons. More recently these engines have been super-

gether with the direct thrust on the coupling rods and the unrestricted length of axle bearings due to the use of straight axles are points in favor of this arrangement. On the other hand, inside cylinders provide a more steady running engine and enable lighter counterbalance weights to be used, due to the closeness of the cylinder centers, and it is interesting to point out that the Great Central, after having used six-coupled engines with outside cylinders, has adopted the inside cylinder design in its most recent construction. Four cylinders as a compromise between the two have lately re-



Six-Coupled, Two-Cylinder, Superheater Locomotive, London & North Western

seded by some of the same type but having three cylinders and fitted with Schmidt superheaters.

The Caledonian Railway was the first to introduce 4-6-0 engines of the largest class. They were designed by J. F. McIntosh to conduct the heavy West Coast Dining Car trains over that road between Carlisle and Glasgow and had, when first built, 21-in. cylinders—the largest ever used in express service at that time. The cylinders were inside the frames and the leading axle was the crank axle. The cylinders subsequently were reduced to 20 in. in diameter and more recently further engines of this type were built having 20-in. cylinders and some detail modifications, such as the substi-

ceived attention, and the London & North Western and the Great Western, especially the latter, have large numbers of four cylinder simple superheater engines at work giving fine results.

When considering cylinders, it is natural to turn to the question of compounding, which in England has been in the past a much debated point. The late F. W. Webb of Crewe for many years upheld the use of compound cylinders, more particularly his own three cylinder system as exemplified in his "Greater Britain" or "Queen Empress" type and latterly by the four cylinder "Jubilee" type. At the present time the only compounds of note are those running on the Midland

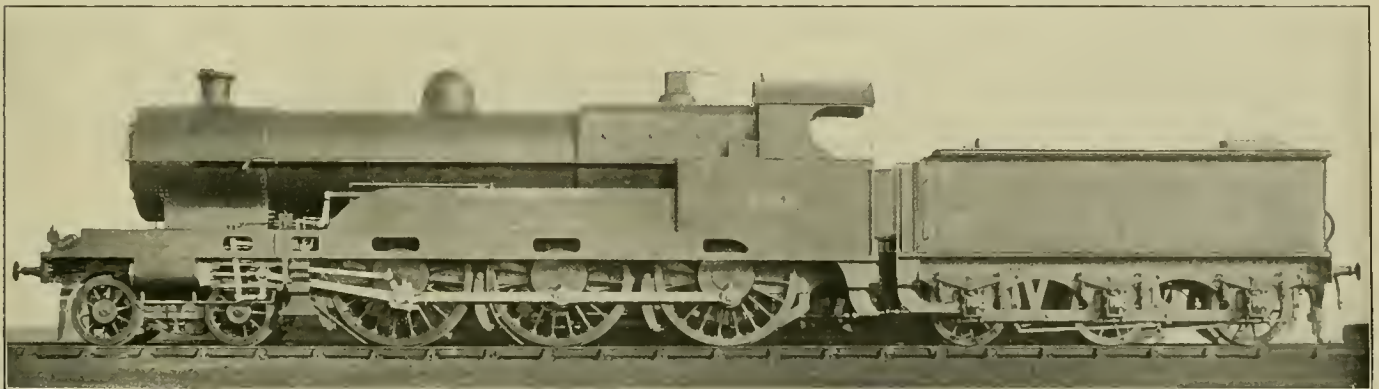

Six-Coupled, Four Cylinder, Superheater Locomotive, London & North Western

tution of direct stays for staying the firebox crown instead of roof bars, and some alteration in the size of the motion bearing surfaces. Now all have been rebuilt with Schmidt superheaters and fitted with 20½-in. cylinders having piston valves, the steam pressure being 180 lb. against 200 lb. originally used.

From what has been said of the six-coupled design, it will be seen that some designers favor inside cylinders and others use outside cylinders and connections; with the exception of the Caledonian and the London & North Western, however, nearly all the six-coupled express engines in use have outside cylinders. No doubt, the long connecting rods obtained, to-

Railway and known as the Smith three cylinder system, the arrangement comprising the use of one high pressure cylinder exhausting into two low pressure cylinders, which is exactly the reverse of the Webb system.\*

Other features of British practice are the universal use of plate frames and of round topped outside fireboxes, though this latter feature is not so universal now as a few years ago. Direct roof stays are being used much more than formerly, as they make for a better circulation over the crown sheet of the firebox. Some designers use direct stays entirely, those

\*There are three De Glehn compound engines in express service on the Great Western Railway.

at the tube sheet end arranged to permit of the upward expansion of the firebox, and others use a few roof bars running transversely across the firebox at the tube sheet end in order to allow for upward expansion, the rest of the load being taken by direct stays. Owing to the increased size of boiler barrels, together with the use of narrow fireboxes, the back sheet of the outside firebox is sometimes dished inwards. This facilitates the removal of the inside box for repairs and at the same time makes it easy to close the rivets holding the back plate by hydraulic pressure. Due to the greater steaming capacity of modern boilers, it is now common to provide four safety valves. Water tubes of any kind do not find favor, though at one time this was a feature of the London & South Western engines, these engines having two nests of tubes running across the firebox. Brick arches are always used.

Piston valves are much used, operated by Walschaert or Joy valve motion. Owing to the introduction of piston valves of the solid ring type as distinct from the segmental collapsible ring form still used to some extent on the Midland, North Eastern and other lines, cylinder covers are usually fitted with spring loaded water relief valves and whenever piston valves are used, it is the practice to fit automatic air valves to the steam chests. The means usually adopted for operating the reversing gear is a wheel and screw. Some rail-



Great Northern Two-Cylinder, Atlantic Type Locomotive

ways, however, use a steam gear consisting of a small steam cylinder and a water cylinder for holding the gear in the desired position.

On the subject of brakes, the most usual practice is to fit a steam brake on the engine and tender, which works automatically with the continuous brake on the train, when this brake is the automatic vacuum, or independently if desired. Some modifications have now, however, taken place regarding this practice and the London & North Western now use only the vacuum brake which operates on the engine and tender.

The most noticeable improvement in modern locomotives is, undoubtedly, the introduction of superheaters. All new express locomotives are so fitted and many older engines have been rebuilt with superheaters and larger cylinders, the latter feature being necessary if the full value of the superheater is to be realized. The introduction of fire tube superheaters causes some modification in the heating surfaces and Table I shows particulars of the heating surface of boilers before and after being fitted with superheaters. The figures obtained in column 2 are obtained by assuming that 60 per cent of the evaporative power of the boilers is in the tube heating surface.

When superheaters were first introduced, damper gear was always considered necessary to protect the elements from becoming overheated when the regulator is closed, and while a number of railways still use dampers, either worked by hand or automatically, others have dispensed with them altogether.

TABLE I.—DIMENSIONS AND PROPORTIONS OF MODERN BRITISH EXPRESS LOCOMOTIVES

Railway	London & North Western		Great Central		Great Northern		North Eastern		Great Western		Midland		Lancashire & Yorkshire	
	4-6-0 2	4-6-0 4	4-6-0 2	4-4-2 2	4-4-0 2	4-4-2 2	4-4-2 2	4-4-2 3	4-6-0 2	4-6-0 4	4-4-0 3	4-4-0 3	4-6-0 4	4-6-0 4
Type	20½ in. by 26 in.	16 in. by 26 in.	21½ in. by 26 in.	20 in. by 24 in.	19 in. by 26 in.	16½ in. by 26 in.	18½ in. by 30 in.	15 in. by 26 in.	11, 11, 19 in. by 26 in. 2 L, 1 V—21 in. by 26 in.	11, 11, 19 in. by 26 in. 2 L, 1 V—21 in. by 26 in.	11, 11, 19 in. by 26 in. 2 L, 1 V—21 in. by 26 in.	16 in. by 26 in.	16 in. by 26 in.	
Cylinders, diameter	6 ft. 3 in.	6 ft. 9 in.	6 ft. 9 in.	6 ft. 8 in.	6 ft. 10 in.	6 ft. 8 in.	6 ft. 8½ in.	6 ft. 8½ in.	6 ft. 8½ in.	6 ft. 8½ in.	6 ft. 8½ in.	6 ft. 3 in.	6 ft. 3 in.	
Boiler pressure, lb. per sq. in.	175	175	2,219.0	1,884.0	1,579.0	1,798.9	1,599.0	1,687.0	1,599.0	1,687.0	1,599.0	2,317.0	2,317.0	
Heating surface, tubes, sq. ft.	1,439.59	1,647.2	1,833.3	1,411.0	1,884.0	1,798.9	1,555.0	1,584.0	1,555.0	1,687.0	1,555.0	1,900.0	1,900.0	
Heating surface, firebox, sq. ft.	1,572.92	1,818.4	2,386.0	2,027.0	1,737.0	1,978.9	1,737.0	1,841.0	1,737.0	1,841.0	1,737.0	2,507.0	2,507.0	
Superheater heating surface, sq. ft.	324.58	413.6	440.0	570.0	.....	.....	.....	.....	.....	.....	.....	.....	.....	
Total equivalent* heating surface, sq. ft.	2,059.5	2,438.0	3,046.0	2,872.0	.....	2,773.9	2,184.0	2,336.0	2,184.0	2,336.0	2,184.0	.....	.....	
Grate area, sq. ft.	25.0	30.5	27.0	21.0	.....	27.0	27.0	27.0	27.0	27.0	27.0	27.0	27.0	
Tractive effort, lb.†	21,000	24,300	21,891	17,340	21,891	17,000	24,300	27,634	24,300	27,634	24,300	26,862	26,862	
Cylinder, volume per mile, cu. ft.	5,340	6,025	4,430	4,430	4,196	4,800	4,655	5,363	4,655	5,363	4,655	6,580	6,580	
Weight on engine only, lb.	104,720	132,160	126,560	80,520	93,280	88,704	129,750	124,096	129,750	124,096	129,750	131,200	131,200	
Weight of complete axle in working trim, lb.	148,512	174,250	168,560	156,256	132,160	171,808	161,280	169,344	161,280	169,344	161,280	172,648	172,648	
Superheating surface, per cent of the total heating surface	17.0	18.5	15.5	21.9	.....	21.0	14.0	15.2	14.0	15.2	14.0	.....	.....	
Cylinder volume per mile	.....	.....	.....	.....	2.34	.....	.....	.....	.....	.....	.....	.....	.....	
Cylinder volume per mile	2.54	2.49	1.77	1.54	.....	1.80	2.12	2.30	2.12	2.30	2.12	.....	.....	
Equivalent heating surface	213.6	197.5	208	142	155.4	183.0	167.9	198.9	167.9	198.9	167.9	248.0	248.0	
Weight on coupled axles	5.0	5.4	5.57	4.64	4.21	4.94	5.38	4.47	5.38	4.47	5.38	4.5	4.5	
Total engine weight	78.0	78.0	59.5	60.16	76.0	68.4	78.9	77.8	78.9	77.8	78.9	68.0	68.0	
Total heating surface	72.1	70.2	55.0	54.4	.....	61.5	73.8	72.4	73.8	72.4	73.8	.....	.....	
Weight on coupled axles, per cent of the total engine weight	70.0	75.9	75.2	51.5	70.6	52.4	80.2	73.4	80.2	73.4	80.2	64.7	64.7	

\* Equivalent heating surface = total evaporative heating surface + 1.5 times the superheating surface. † Mean effective pressure 85 per cent of boiler pressure.  
‡ Actual heating surface = total evaporative heating surface + the superheating surface.

An example of the latter is to be found in the Great Central practice. This company's engines are fitted with an arrangement of steam jets which come into action when the steam blower is in use, and are arranged to set up a counter draught down the large flues containing the elements, in that way protecting them from becoming overheated. The superheater engines on the Great Northern have a large air valve fitted to the superheater header. This valve opens when the regulator is closed and admits air into the elements comprising the superheater, thus preventing them from becoming overheated when there is no steam passing through. The valve is placed on the smokebox behind the stack, and is not shown in the photograph, as the engine illustrated works with saturated steam; otherwise in appearance the superheated and saturated engines are alike. Another method adopted to keep the elements from getting overheated is to arrange a supplementary supply of steam to be automatically supplied to the elements; when the main supply of steam to the cylinders is shut off the supplementary steam is circulated through the superheater and then through the cylinders and valve chests. It thus acts as a lubricating medium when the engine is running with the regulator closed, and when the engine is standing serves to keep the cylinders warm. This arrangement is used by the North Eastern Railway in place

which would otherwise be used by the eccentrics of the Stephenson gear is utilized by a central bearing, carried by a steel casting bolted to the frame stretcher in front of the firebox and to the motion plate carrying the guide bars. The crank axle is built up and the crank webs are extended to form balance weights.

The most modern express engines built have four cylinders and one of the photographs shows the latest type of engine designed for the heaviest express service on the London & North Western. The four cylinders are placed in line across the front of the engine and all drive on the front coupled axle. The inside cranks are placed at 180 deg. to the outside cranks on the same side of the engine so that they travel in opposite directions, which enables one set of valve gears, in this case Walschaert, to be used to operate the two valves. The valves are of the cylindrical type giving inside admission. This arrangement is effected by fitting the valve gear to the outside motion and extending the valve stems through the front covers of the steam chests, connection here being made to horizontal vibrating levers of the first order, which in turn are coupled to the inside cylinder valve spindles. Each pair of cranks are at 90 deg. to each other. The crank axle is built up and has a central bearing. The boiler is large, having a superheater and a Belpaire firebox with 31

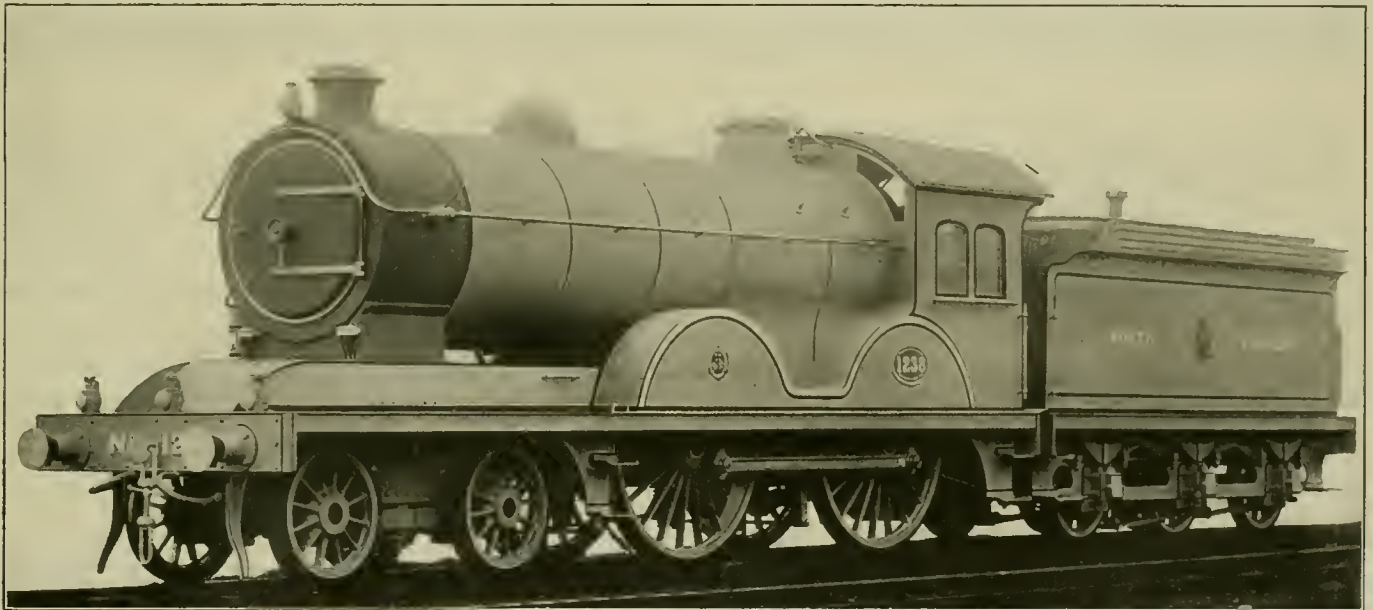

North Eastern Four-Coupled, Two-Cylinder Locomotive

of dampers. The practice on the London & North Western is to use dampers, the opening and closing of which is done by hand, a lever being fitted in the cab on the driver's side for this purpose. The Great Western engines have dampers which open and close automatically with the opening and shutting of the throttle, a small steam cylinder being fitted for operating them.

The engines selected for descriptive purposes are representative of modern construction and are, with the exception of the Midland compound, the North Eastern 4-4-0 and the Lancashire & Yorkshire 4-6-0 engines, all fitted with fire tube superheaters. The London & North Western engines illustrated have been introduced to handle important main line trains, and the inside cylinder class is really similar in design to engines introduced in 1906 to work on the northern section of the line which runs over the Westmoreland mountains. This engine is fitted with a Schmidt superheater and inside admission piston valves operated by Joy valve motion through the medium of rockers. The Joy valve gear is the standard on all modern two cylinder engines in use on the London & North Western; the space between the crank webs

sq. ft. of grate area. These engines, of which several are now at work, can maintain 1,400 i.hp. and are the heaviest express locomotives in the country, weighing without tender 78 tons in working trim. The automatic vacuum brake operates on the engine and tender.

The Great Central Railway use the type of engine shown to conduct their heaviest traffic. The engines are the largest of their type in use, and are noteworthy from the fact that they have boilers containing more heating surface than any other express engines in Great Britain and show what can be accomplished within the restrictions imposed by the British running dimension outline. These engines have two cylinders 21½ in. in diameter by 26 in. stroke. Piston valves are placed above the cylinders and are worked by the ordinary link motion through rockers. The piston rods are extended to pass through the front cylinder covers, a practice now quite general since the introduction of superheated steam. Exceptions are, however, to be noted in the case of the London & North Western and Great Western four cylinder engines and the North Western three cylinder engines. In these instances necessity for this detail does not arise, owing

to the fact that the pistons are of much smaller diameter. The use of piston valves is also almost invariable with superheated steam and both valves and pistons are oiled by forced feed lubrication.

The Great Northern uses the engine illustrated for heavy fast traffic between London (Kings Cross) and York. This engine has already been briefly mentioned, and is remarkable for its boiler capacity and its wide firebox, the latter feature a novelty in British practice. The cylinders are 20 in. in diameter with a piston stroke of 24 in., which is shorter than is usually employed. In order to further reduce the centrifugal force set up by the coupling rods, the

without the intervention of rockers. Several of these engines have been fitted with superheaters.

Four-coupled bogie engines of similar general dimensions to those just noticed are to be found on the London & North Western, the Great Central\* and the South Eastern & Chatham, and it can safely be said that where a maximum of 2,000 sq. ft. of heating surface will provide the power required this type of engine has many advantages. Such engines on the London & North Western equipped with superheaters have demonstrated their ability to maintain 1,100 i.hp. Naturally, the size of engine that can be used having the 4-4-0 wheel arrangement depends on the allowable



North Eastern Three-Cylinder, Atlantic Type Locomotive

main crank pins are turned eccentric and the throw of the coupling rods reduced to 22 in. The engines are fitted with superheaters and piston valves. The bogie axles are equipped with independent coil springs, two to each journal instead of the usual long inverted leaf spring, transmitting its elasticity to each journal by means of a compensating beam, as is usually done in English practice. The bogies are also fitted with the American swinging link arrangement.

The next engines to be considered are in use on the North Eastern which forms the middle link in the East Coast route between London (Kings Cross) and Scotland. The North Eastern provides the power for running the joint stock trains

weights. In England, engines of this type weigh about 60 tons and carry 39 tons on the coupled axles.

The North Eastern 4-4-2 type engine illustrated is perhaps one of the most interesting of modern express locomotives. It is representative of a class designed by V. L. Raven, the present chief mechanical engineer, to deal with the most important traffic. It has three cylinders placed in line across the front of the engine, driving on the leading coupled axle with cranks at 120 deg. They are cast together in one piece, together with their valve chests. The valve chests for the outside cylinders are at the side of their respective cylinders and the center cylinder has its valve chest on the top. Piston



Great Western Six-Coupled, Two-Cylinder, Superheater Locomotive

between York and Berwick, and it is upon this service that the two engines illustrated are utilized. The four-coupled engine was introduced some few years ago by W. Worsdell, and indicates an engine which reaches dimensions approaching the maximum possible with this wheel arrangement. The cylinders placed between the frames are arranged with their axis inclined slightly upwards and the piston valves are on the top of the cylinders placed with their center line inclined downwards to the center of the crank axle; thus the valves can be worked direct by the valve motion which in this case is the ordinary Stephenson gear,

valves are used, operated direct by the ordinary double eccentric valve motion, the whole arrangement being particularly neat and calling for some clever designing. The single throw crank axle has circular crank webs common to all North Eastern engines. This enables the crank axles to be finished entirely in the lathe. In accordance with standard North Eastern practice, they are fitted with the Westinghouse brake.

The most important express traffic on the Great Western is conducted by locomotives of the types illustrated. One has

\*For a description of the Great Central 4-4-0 engines, see *Railway Mechanical Engineer* for August, 1916.

two outside cylinders which are remarkable for the long stroke of the pistons, namely, 30 in., and the other is a four cylinder engine having two cylinders inside arranged to drive on the leading coupled axle. The outside, as will be seen, drive on the second axle; in that way the strains are divided. The arrangement of the cranks is exactly similar to the four cylinder engines of the London & North Western already considered; but in this case Walschaert valve gear is applied to the inside motion, the valves for the outside cylinders being driven by rocking levers in the same way as in the

placed on the safety valve mounting. The water is then distributed by means of trays in the boiler barrel. In this way boiler strains due to local contraction caused by this introduction of cold feed water in close proximity to the boiler plates is eliminated. It will be noticed that the Great Western engines are without steam domes, the steam supply to the cylinders being obtained through a pipe running through the steam space in the barrel of the boiler to a point over the firebox crown sheet, the regulator valve being placed in the smokebox. The continuous brake used on the Great West-



Great Western Six-Coupled, Four-Cylinder Superheater Locomotive

London & North Western engine except that in this case the rockers are driven from the main valve spindle for the inside valves instead of by extensions through the front covers of the valve chests. This is necessary owing to the position of the outside cylinders. Great Western practice in boiler design differs somewhat from ordinary British practice, and the boilers of these engines are the outcome of careful experimenting.\* A Belpaire firebox is used, together with a

ern is the automatic vacuum and an air pump driven from one of the cross heads is used to maintain the vacuum in the train pipe and reservoirs when running, in place of the small ejector generally employed. This method is also used on the London & North Western and the North Staffordshire Railways.† Fire tube superheaters are fitted and the steam pressure employed is 225 lb., which is unusually high, especially in the case of superheater engines. Both pull trains



Four-Coupled, Three-Cylinder Compound Locomotive, Midland Railway

long tapered barrel, the general idea being to get as much water as possible at the hottest part of the boiler and at the same time to increase the water line area where most steam is generated. The bogie wheels are fitted with brake blocks, contrary to ordinary English practice. Another distinguishing feature of Great Western practice is the method adopted in supplying the feed water to the boilers. This is fed into boiler steam space by means of pipes leading to check valves

of over 400 tons at 60 miles per hour over the main line.

The Midland engine shown is a three-cylinder compound with cylinders arranged on what is known as the Smith system. One high pressure cylinder is placed between the frames with connection to the leading coupled axle through a single throw crank axle, and the two low pressure cylinders are placed one on each side of the engine, connecting, as

\*See paper on "Large Locomotive Boilers" by G. J. Churchward, Proceedings Institute Mechanical Engineers, 1906.

†The most recent locomotives on the North Staffordshire Railway are equipped with combination ejectors of the Gresham and Craven type and the use of air pumps is discontinued.

shown, to the leading coupled wheels. The regulator valve in the dome has an additional jockey valve, the arrangement being such that on the first movement of the handle controlling the regulator the jockey valve only is opened. The jockey valve opens a port connected to a small pipe, which conveys steam direct from the boiler to the low pressure steam chests. Connecting both ends of the high pressure cylinder with one of the low pressure steam chests are two pipes fitted with spring loaded non-return valves, which open when the pressure in the low pressure steam chest is greater than the pressure in the high pressure cylinder. It follows then that in starting the high pressure piston simply floats in its cylinder and the train is started by the low pressure cylinders only. On further movement of the regulator handle the jockey valve closes the supply of steam from the boiler to the low pressure steam chests and opens the main valve supplying steam to the high pressure cylinder, and the pressure now being greater in the high pressure steam chest than in the low pressure steam chest, the non-return valves are forced to their seats, thus cutting off connection between the high pressure and low pressure cylinders, except through the high pressure exhaust, the engine, therefore, commencing to work compound. Steam is distributed in the high pressure cylinder by a piston valve placed below the cylinder, and as it has its axis inclined upward to the center of the crank

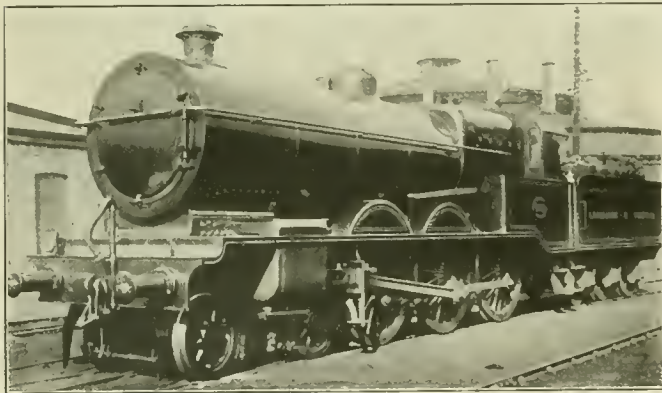

Lancashire & Yorkshire Four-Cylinder, Six-Coupled Locomotive

axle it is driven direct without the intervention of rockers. Ordinary unbalanced flat valves are used for the low pressure cylinders, driven by the ordinary link motion. The reversing gear consists of a wheel and screw, the high and low pressure gears being operated together. Independent adjustment of the high and low pressure motions is not provided for, it having been found to be unnecessary. The low pressure cranks make an angle of 90 deg. with each other, and the central high pressure crank is placed at an angle of 135 deg. with the low pressure cranks. The driving wheels are 7 ft. in diameter and the high pressure cylinder is 19 in. by 26 in., the low pressure being each 21 in. by 26 in., and the steam pressure 220 lb. Engines of this type have been run in competition with engines of similar general dimensions having two simple cylinders, and their designer, R. M. Dealey, writing in *The Engineer* of December 17, 1909, stated that the compound engine consumed .129 lb. of coal per ton-mile against .139 lb. consumed by the simple engine. It must, however, be pointed out that the simple engine worked with a boiler pressure of 180 lb. as against 220 lb. carried by the compound. There are 40 of these engines in service, and latterly some have been superheated with excellent results.

The Lancashire & Yorkshire utilizes the large type of six-coupled engine illustrated to work the heaviest express train over the main line between York, Manchester and Liverpool. The engines were also designed with a view of being able to haul important fast goods traffic. The coupled wheels are 75 in. in diameter and there are four cylinders, each 16 in.

diameter, with a piston stroke of 26 in. The arrangement of the cranks is exactly the same as in the Great Western four-cylinder engine described, and in order to obtain sufficient length for the inside connecting rods the inside cylinders are placed well forward under the smokebox. The Joy valve motion, which has been the standard for many years on the Lancashire & Yorkshire, is used and is applied to the inside running gear. The engines are not superheated, but, as will be seen with the above dimensions, together with a boiler having 2,507 sq. ft. of heating surface and working at 180 lb. steam pressure, are very powerful locomotives. They were very fully described in a paper read before the Institute of Mechanical Engineers by G. Hughes, the chief mechanical engineer of the Lancashire & Yorkshire, in 1909. Besides this particular class of engine the Lancashire & Yorkshire has in use a number of powerful engines of the 4-4-2 type, having inside cylinders and coupled wheels 87 in. in diameter. When first introduced, these engines possessed the distinction of having the largest boilers of any engine in Great Britain—the total heating surface being 2,050 sq. ft.

From the illustrations it will be seen that the six-wheeled tender is the most usual type, though the Midland, Caledonian and London & South Western use the double bogie type to a limited extent. The large 4-6-0 engines on the Caledonian have double bogie tenders on account of the large size of the engines and the absence of track troughs. In general, the use of water troughs and superheaters makes tenders having a greater capacity than 5 tons of coal and from 3,000 to 4,000 gallons of water unnecessary.

The table of dimensions and proportions shows the chief characteristics of British practice. The cylinder volume swept through per mile in cubic feet has been calculated and compared with the heating surfaces and grate areas, thus giving an idea of the steam using capacity of the engine compared with steam producing power of the boilers, and the figures relating to the heating surface and engine weight and those comparing the total weight and adhesive weight give information, the importance of which need not be insisted on here. Weights expressed in tons and capacities in gallons in the text of this article are all English measure.

In an article of this kind it is impossible to describe more than a limited number of engines, but those mentioned are representative of recent construction and are believed by the writer to show the modern tendency in the design of British express locomotives. The photographs here reproduced are all by F. Moore, Finsbury Circus, London, E. C.

## MECHANICAL DESIGN OF ELECTRIC LOCOMOTIVES\*

BY A. F. BATCHELDER

The purpose of this paper is to bring to the attention of the Society some of the important features in the mechanical design of electric locomotives, with a view of having a more common understanding of the requirements and the method of meeting them. These features may be listed in the order of their importance as follows:

- 1—Safety of operation
- 2—Adaptability to service conditions
- 3—Reliability in service
- 4—Convenience of arrangement as affecting safety and efficiency of operation
- 5—Power efficiency (affected by mechanical design)
- 6—Service time factor (ratio, time available for service to total time)
- 7—Cost maintenance of permanent way
- 8—Cost maintenance of locomotives
- 9—First cost.

### SAFETY OF OPERATION

The steam locomotive has been developed by degrees to such a state of perfection that it is common to see it operate at near 80 m. p. h. and with perfect safety; but no one

\*A paper which will be presented and discussed at the Railroad Section of the annual meeting of the American Society of Mechanical Engineers, held December 8, 1916, in New York.



would think of operating at this speed backwards. With the coming of the electric locomotive, the railroad operator is not content with single end operation, but must have a locomotive that will operate equally well in either direction. This does not impose any serious difficulties in the design of locomotives which operate at speeds under 50 m. p. h., but with locomotives for the higher speeds it presents new problems or at least it requires the most careful consideration of the running gear details, to obtain the most satisfactory results as to tracking and the effect on the rails and road bed.

The steam locomotive has what now seems to be natural characteristics to allow high speed operation in one direction. These characteristics are low center of gravity at the front end carried on the center pin of a two axle guiding truck tending to prevent rolling over and having but little effect on the guiding, and high center of gravity on the rear end with inside journal bearings allowing the locomotive to roll and increasing the time element, which thus reduces and distributes the lateral pressure against the rail over a longer distance. This increases the vertical pressure on the rail, thus holding it more firmly in place. These same characteristics can be obtained in electric locomotives by the sacrifice of double end operation.

The advantages gained in operating the electric locomotive in either direction are so important that means should be provided for satisfactory double end operation. One way of doing this is by using a four wheel guiding truck at each end of the locomotive. With the use of the extra truck, however, the importance of a high center of gravity largely disappears. The lateral pressure against the rail at the rear end now appears at the truck flanges rather than at the flanges of the driving wheels and the high center of gravity no longer provides the same increased vertical pressure on the outer rail at the point of the maximum lateral pressure. The lateral stresses from guiding the main frame being taken at the center pin of the two guiding trucks, the additional vertical pressure on the outer rail is dependent upon the height of these center pins rather than upon the height of the center of gravity of the main frame above the wheel hubs, thus leaving less advantage to be derived from a high center of gravity.

To demonstrate more clearly, it is well to see what happens to a locomotive when entering a curve, which is also illustrative of its action on tangent track when oscillating from one side to the other. A locomotive having a high center of gravity and with two driving axles guided by a two-axle swivel truck will serve to illustrate the action. As the locomotive enters the curve, its tendency is to continue on in a straight line but the flange of the leading wheel gradually comes in contact with the outer rail, giving the guiding truck an angular motion about its outer rear wheel and exerting a lateral pressure against the center pin, thus giving the main frame an angular motion around its outer rear wheel.

The lateral pressure tending to displace the rail at the leading wheel is the amount required to slip the two inner wheels, and to accelerate the truck around its outer rear wheel, plus one-half the amount required to slip the two leading drivers and the rear inner driver, and to accelerate the main frame around its rear driving wheel, plus its relative portion of the centrifugal force of the whole locomotive. The lateral pressure tending to displace the outer rail at the rear wheel of the leading truck is the amount of reaction from slipping the two inner wheels and the angular acceleration of the truck plus one-half of the amount required to slip the two leading drivers and the rear inner driver and to accelerate the main frame around its rear outer driving wheel, plus its relative portion of the centrifugal force of the whole locomotive.

The lateral pressure tending to displace the outer rail at the rear wheel of the main frame is the amount of reaction from slipping the two leading drivers, the inner rear driver and the angular acceleration of the main frame plus its relative portion of the centrifugal force of the whole locomotive. The greater weight being concentrated at the drivers, and the distance of the truck center pin from the main truck wheels being greater, and the fact that there is but one wheel to take the strain, it follows that the point of the greatest concentrated lateral pressure is at the rear outer driving wheel.

The above disregards the important factor of time, in the accelerating and centrifugal forces due to the rolling, governed by the height of the center of gravity above the wheel hubs, which tends to reduce the lateral pressure at the rear outer driving wheel. With a high center of gravity above the wheel tread the accelerating and centrifugal forces also tend to tip the locomotive up on the outer driving wheels, relieving the weight from the inner wheels and thus lessening the force required to slip them, at the same time increasing the adhesion between the outer rail and tie by the additional weight. On good road bed and rails the locomotive described is capable of being run at above 80 m. p. h. without any apparent bad effect on the track.

If this locomotive is operated in the opposite direction, the lateral stresses at these wheels are of the reverse order, the guiding force now being applied at the driving wheel flanges and the reaction taken through the center pin to the truck wheel flanges. The swivel truck, now trailing, is free to oscillate from one side to the other, and the reaction from the force of turning the main frame may be applied at the center pin when the truck wheel flanges are tight against the inner rail. The force is thus allowed to accelerate the truck as well as the main frame through the gage clearance to the outer rail, thus adding momentum, the value of which depends upon the lateral distance through which the truck is moved. As the vertical pressure on the rail is limited to the normal weight at the wheels plus the vertical component of the force applied only at the height of the center pin of the truck, the relative lateral to the vertical pressure at the wheels of the truck may be greatly increased. A number of observations have appeared to confirm the fact that the action of the trailing truck above described is one of the most important in producing excessive lateral pressures against the rail in a symmetrically built electric locomotive with similar trucks at both ends. It will be seen therefore that while the swivel truck is desirable as a guiding agent at the front end, it is not as desirable at the rear end, and means must be provided to prevent oscillation of the truck and to accomplish the same results as the high center of gravity in a single end locomotive.

To accomplish these results, it is necessary to reduce the momentum effect and to reproduce the equivalent of the time element factor and of the increase of vertical pressure on the outer rail that is characteristic of the high center of gravity single end locomotive.

The momentum effect can be reduced by introducing resistance against swivelling, thus restricting the truck from oscillating from one side of the track to the other, the amount of this resistance to be determined by the allowable amount that can safely be applied to the truck when leading. To reproduce the time element factor, lateral movement can be given to the truck center pin by any of the several methods for giving lateral movement to the leading truck center pins on locomotives. However, the writer has obtained the best results with the method that is the nearest to constant pressure and dead beat, as it also tends to prevent oscillating. To increase the vertical pressure on the outer rail the center bearing of the truck can be made wide, thus allowing the vertical component of the lateral pressure at the center of

gravity to be transferred through the bearing to the wheel, or with the narrow center bearing the height may be made such that the lateral pressure at that point will result in an increased vertical component independent of the height of the center of gravity.

It is the writer's opinion that the double end locomotive, while its characteristics are different, can be designed for high speed with safety equal to the single end locomotive, and this regardless of the height of the center of gravity.

#### ADAPTABILITY TO SERVICE CONDITIONS

The electric locomotive, besides being required to operate in either direction, is often also required to be adapted for operating high speed passenger trains and heavy low speed freight trains over main line tracks, to negotiate sharp curves, and to be easy on light track and bridge structures. With locomotives having geared motors, the requirement of operating the passenger and freight trains can often be met by changing the gearing to obtain the proper speed and draw bar pull. The running gear can be made with trucks of short wheel base and coupled together, the number of trucks depending upon the required weight of the locomotive for its maximum draw bar pull, and also on the allowable weight per axle. With such a design curves of very short radius can be operated over and the weight per axle can be such as to allow operation over light structures.

#### RELIABILITY IN SERVICE

When the design is such that it is safe to operate at the required speeds and is proper for the curves and other service requirements, and a liberal factor of safety is provided for the parts subjected to strain, the reliability in service affected by the mechanical part of the locomotive depends mainly upon the bearings, their lubrication, and the method of power transmission from the motors to the drivers. It is necessary therefore to provide effective lubrication and as few bearings and as simple driving mechanism as the design of the motors will allow.

After providing all the safety appliances recommended by the Interstate Commerce Commission, it is important to arrange for the most convenient location of the operator to allow him an unobstructed view of the track and signals, to place within easy reach the air brake valve and locomotive signal device handles, as well as the reverser and power controller handles, keeping in mind the importance of making them so free from complication that the operator will require the least amount of thought to manipulate any of the devices and be free to respond to signals and look out for emergencies.

The arrangement for housing the electrical apparatus and its position in the cab must be governed largely by its design, but it is important to arrange it so that its operating parts are accessible and easy to inspect, and at the same time are protected against persons coming in contact with any live parts.

#### POWER EFFICIENCY

The power efficiency as affected by the mechanical design is governed largely by the type of the traction motors. It is apparent that the gearless motor mounted directly on the axle allows the design of the maximum efficiency on account of its few bearings and its absence of gearing and moving parts. The gearless motor which is mounted on a quill and driving through springs to the wheels may be considered second in its possibilities for high efficiency design, it having additional bearings and a greater number of moving parts. The single reduction geared motor with its additional bearings and gear losses can be given third place in its possibilities for high efficiency design. The single reduction geared motor driving through gears and side rods to the wheels may be placed fourth. The gearless motor

driving through side rods and jack shaft to the wheels should be placed fifth.

#### SERVICE TIME FACTOR

The service time factor is dependent upon the ability of the locomotive to operate under all its service conditions and without undue strains which requires a liberal design of its wearing parts. In addition to this it depends on the simplicity of its design and the ease with which its parts can be inspected, adjusted, repaired, or replaced.

#### COST OF MAINTENANCE OF PERMANENT WAY

The cost of maintenance of the permanent way is a very important item and can be increased or reduced by the design of the locomotive. The lowest cost is obtained when the locomotive meets its service requirements without undue strains, when the rotating parts are balanced, the weights per axle are suitable for the structures, a suitable equalizing system is provided to maintain the proper weight distribution, and when provision is made to protect against flange wear.

#### COST OF MAINTENANCE OF LOCOMOTIVES

The cost of maintenance of the locomotive is dependent upon its safety of operation, its adaptability to service conditions, its reliability, its convenience of arrangement, and the same items that enter into its service time factor. It is also governed by the same conditions as affect the maintenance of the permanent way. The care with which the material is selected, the quality of workmanship, the ease with which the parts can be inspected, adjusted, repaired or replaced, and the simplicity of the design are the most important features that govern the maintenance cost.

#### FIRST COST

The first cost of a locomotive will depend largely upon the design chosen, but its importance, except at the time of purchase, becomes of little moment when taking into consideration the eight foregoing features. With two locomotives designed for the same service the cost of the difference in the efficiency and in the locomotive maintenance alone for one year may when capitalized amount to a sum representing a considerable proportion of the first cost of one of the locomotives.

The writer feels that too much importance cannot be given to developing to the utmost the mechanical parts of the electric locomotive, that are the simplest in design and the highest in efficiency. From the present outlook, the locomotive for high speed passenger service with the gearless motor, its armature being mounted directly on the axle, and the locomotive for freight and switching service with the single reduction geared motor, mounted on and geared to the axle, lend themselves best to simple design and low cost of maintenance.

**ACIDITY OF LUBRICATING OILS.**—It is necessary for oil to be as free from acid as possible, and to determine whether it is or not the oil should be placed in a glass vessel and a small quantity of copper oxide added. Should there be acid present, the oil will change to green or blue; if not, no change will take place. Litmus paper can be used for the same test, as it turns red when there is the slightest trace of acid.—*Power.*

**COLORING GLASS AS AN AID TO THE FIREMAN.**—The condition of individual fires cannot be judged with the naked eye. Some sort of colored glass in a frame, hung directly where it is to be used, gives the operator a better means of judging the thickness of fires, movement of the fuel bed and the presence of holes or dirty places, so that he can judge the rate of supply of fuel and air to maintain a uniform thickness of fires so necessary to give the best furnace conditions.—*Sibley Journal of Engineering.*

# TRAVELING ENGINEERS' CONVENTION

## President's Address and Reports on Mechanical Firing of Locomotives and Smoke Elimination

THE twenty-fourth annual convention of the Traveling Engineers' Association was held at the Hotel Sherman, Chicago, October 24 to 27, inclusive, President J. R. Scott, assistant superintendent of locomotive performance, St. Louis & San Francisco, presiding. The secretary reported a total membership of 1,056 and the treasurer a cash balance of \$4,080.75.

### PRESIDENT'S ADDRESS

The whole aim of this association is an educational one. It brings together trained men from all sections of the country, who by working under a variety of conditions, are in a position to exchange ideas, not only on the convention floor, while discussing subjects, but in casual conversation during intermissions, also in the exhibit room, while viewing the modern equipment so extensively brought before us for exhibition and inspection. The knowledge thus gained is disseminated by us to others, and especially to our enginemen, who by constant instructions and training become more proficient in their work, and render better service to the companies by whom they are employed. The exhibits are more extensive this year than ever before. It is therefore desirable that all who can, should avail themselves of this splendid opportunity for educational advancement by carefully examining them. With the modern power of today, we are confronted with many problems that did not exist with the smaller power of the past, and as new appliances are constantly taking the places of the old, it behooves us as traveling engineers or representatives of our employers in whatever capacity, to so familiarize ourselves with all things surrounding our work, that we may be ever ready and willing to direct or assist others, and for which a convention of this character is most profitable.

As a direct result of the great European conflict more than any other cause, the cost of structural materials, metals, and supplies of all kinds necessary for railroad operation, also equipment for construction and maintenance work, has soared high in price. This together with the increased wages of labor, and lack of corresponding returns with which to meet the abnormal operating costs has created a burden which falls most heavily upon all railroads. In order that we may do our part to assist in relieving this unusual strain, we as traveling engineers, should zealously guard the machinery, fuel and supplies under our charge, that the best possible use may be secured from them. Much can be done along these lines by educational meetings wherein the importance of conserving materials and supplies is impressed upon the men. More skillful operation of the locomotive on the road, and greater conservation of supplies and equipment placed on them, together with increased efficiency in the handling of trains are matters that will tend to reduce cost of operation. Therefore, we should give our attention and

special effort to bring locomotive operation to the highest possible standard of economy and good service.

Another matter of unequalled importance is the question of the great railroad strike, which was recently threatened by the four brotherhoods, representing more than 400,000 trainmen and enginemen. Such a strike, regardless of the cause, would have been a calamity beyond words to express, or thoughts to imagine. Although men may differ in opinion as to the action taken to avert this strike, none should differ in opinion as to the importance of warding it off, or the necessity of greater preparedness by national law, to protect the one hundred million people of this nation, their transportation facilities, their properties and industries.

### ADVANTAGES OF MECHANICAL STOKING

The managements depend largely upon us to supervise the fuel expense, representing approximately 25 per cent of transportation expenses, and see that locomotives are in such condition and so equipped and handled that as nearly as possible the maximum rated capacity will be maintained.

The feeding of fuel into locomotive fireboxes by mechanical means has passed the experimental stage, and locomotives are operating at a mechanical efficiency of from 85 to 100 per cent, hauling trains and effecting operating economies that would not be possible under ordinary hand firing conditions. The application of appliances for firing solid fuels mechanically has made quite rapid strides since 1912, and there are now about 1,900 engines fired in this manner.

The average tractive effort of all locomotives in the United States has increased in the past ten years 38.6 per cent; the heavy locomotives of years ago ranging from 36,000 lb. to 42,000 lb. have given place to those ranging from 54,000 lb. to 160,000 lb., and the figures are increasing yearly. The average tons handled per freight train has increased 54.1 per cent in ten years. The gross ton-miles handled per locomotive has increased 11.6 per cent, which shows that we are not getting the full benefit of the increase in tractive effort. With the introduction of larger power units and resultant increased train load, various devices were introduced to secure the rated maximum capacity of the locomotives, such as brick arches, superheaters, etc., but the amount of coal consumed by a locomotive for a trip remained stationary or increased, with the result that those roads using heavy power experienced serious difficulty during the summer months in retaining experienced firemen in service and securing new men of the caliber that it could be expected would later develop into proper material for promotion to engineers. Therefore, if the heavy tonnage trains on the roads in question were to be a success and the cost of operation held to a minimum, the necessity for the "iron fireman" was apparent.

The following figures covering the four railways using the largest number of locomotives with appliances for feeding



J. R. Scott, President,  
Traveling Engineers' Association

fuel mechanically, and by which a large proportion of their freight traffic is handled, show interesting comparisons of average trainloads. (The figures are taken from reports made to the Interstate Commerce Commission.)

FISCAL YEAR ENDING JUNE 30, 1915, COMPARED WITH FISCAL YEAR ENDING JUNE 30, 1904

	Increased average tractive power (Per cent)	Increased average number of tons of freight per train load (Per cent)
Road A .....	43	78
Road B .....	40	72
Road C .....	30.7	72
Road D .....	29	54

(The locomotive fuel cost per ton mile on each road shows a decrease for 1915 as compared with 1904.)

This study is not intended to show that the method of firing the fuel is entirely responsible for the results obtained, as many features, such as brick arches, superheaters, improved design, change in line, and increased activity on part of the transportation officers in more closely following the proper loading of locomotives, have all had a bearing on the matter, and it should be remembered that in all cases of application of appliances for mechanical firing the locomotives were also equipped with the brick arches and superheaters.

The results that are being obtained from mechanical firing of the fuel may be summed up about as follows:

*Increased Tonnage.*

—It has been reported that on some roads the trainload has been increased from 8 to 15 per cent as compared with hand firing, with much the same conditions as to grade and time. Such increase, it will be understood, can only be expected with large power where the advisability of the use of the stoker is clearly indicated.

*Increased Speed.*

—The experience of most roads is that better time is made with the same tonnage on the same grade than with the hand fired engine. The following is quoted from report made by one road:

“It is a daily occurrence on — Division for trains hauled by stoker fired locomotives to overtake trains hauled by hand fired locomotives, and to reduce speed on this account. If all the locomotives on the division were equipped with stoker, there would at once be a further increase in the speed at which trains are put over the road, and this would be more noticeable at periods when the traffic is heavy and line congested, and, therefore, when it is most desirable.”

*Saving in Labor of the Fireman.*—With the type of appliance in most general use, the coal placed in the firebox ranges from 85 to 95 per cent of the total fuel fired. Some trouble has been experienced due to the back corners of the firebox not being filled properly, resulting in the necessity for some hand firing. In this connection, the following comparison of the amount of manual labor connected with firing, compiled from accurate stop watch records made by competent observers, is of interest:

How fired	No. trips	Type engine	Avg. tons in train	Average period on duty (A)	Average manual labor supplying coal to firebox (B)	Per cent (B) to (A)
Hand .....	15	Mikado	2,868	11 hr. 3 min.	2 hr. 22 min.	21.5
Stoker .....	22	Mikado	3,364	12 hr. 34 min.	0 hr. 30 min. 21 sec.	4.5



B. J. Feeny, Vice-Pres., Traveling Engineers' Association

*Elimination of Necessity for Second Fireman.*—The manual labor of supplying fuel to the firebox has been so largely reduced as to settle this question permanently, and on some roads where assistant firemen were provided for certain parts of the runs during the warm months, it is no longer necessary. There has been no necessity for shoveling coal ahead by laborers at intermediate points where it had been necessary during the warm months with hand firing.

*Shaking Grates.*—When the appliances and fire are properly handled, it has been the experience of some roads that grate shaking between terminals is not necessary. While in some localities the character of the coal is such that some shaking is required, with the thinner fire carried as compared with hand firing, less of it is indulged in. The thinner fire also results in saving time in cleaning fires.

*Firemen Follow Engines More Regularly.*

—On account of the reduced physical labor connected with their duties, firemen are inclined to follow their engines resulting in reduction of extra lists, raising standard of new men employed and providing opportunity for better training, so that the firemen will eventually become better engineers.

*Reduced Number of Engine Failures.*—Fewer failures are the rule, due principally to ability to largely overcome defects, such as leaky superheater units, firebox sheets, flues, cylinder packing, valves, etc., which often make it necessary for hand fired locomotives to set off trains. (And likewise this same feature will often cause an increase in fuel consumption, on account of the likelihood of the engine being despatched with such defects as would most likely be remedied on the hand fired engine.)

*Length of Run Increased.*—It has been found on some roads that locomotives could be operated successfully and continuously over two divisions, when this was found impossible under hand firing conditions.

*Smoke Emissions.*—On the line of road with engine using steam it has been found that the density of the smoke can be kept uniform by very careful manipulation. In some restricted smoke districts where more or less switching of the train is necessary, it has been found that in starting with a train after the fire has been built up, the smoke emission cannot be controlled as well as under hand fired conditions where run-of-mine or lump coal is used.

*Fuel.*—Grades of coal, such as nut pea and slack or screenings can be utilized successfully. As to the relative value of four grades of coal found on one road, the accompanying



H. F. Henson, Vice-Pres., Traveling Engineers' Association



W. L. Robinson, Vice-Pres., Traveling Engineers' Association

table and analyses covering five round trips with each grade made under the same conditions will be of interest.

Attention is called to fact that except when haul is small, the use of low volatile screenings is prohibitive, due to their slower burning properties and resultant loss on account of being drawn through the flues and out of the stack when the locomotive is being worked to capacity. It has not been found possible to maintain maximum steam pressure with the slack coal hand fired.

The broadening of the market for fine coal brought about by the increase in number of mechanically fired stationary and locomotive boilers, has greatly narrowed the margin of difference in price of fuel used on hand and mechanically fired locomotives, it having been necessary in some instances for crushers to be installed in order that coal of proper size for use with some types of appliances might be provided.



G. A. Kell, Vice-Pres.,  
Traveling Engineers' Association

lump on hand fired and screenings on mechanically fired locomotives, the consumption on a pounds unit basis is higher with the latter. It has been found, however, that locomotives can be operated with fine coal, such as it would not be possible to hand fire and allow the working of engine to be anywhere near the maximum.

**Steam Pressure.**—In this connection, a railroad officer, following up locomotive operation on a large road, declares:

"The maintenance of the maximum rate of steam production, utilizing full boiler capacity over extended periods at points where the maximum effort of the locomotive is required, has been a most potent factor in the improvement in the handling of trains."



A. G. Kinyon, Vice-Pres.,  
Traveling Engineers' Association

equipped for the purpose now being in operation and in the process of being equipped. As to the results that have been obtained in locomotive service, the following are the conclusions of the standing committee on Powdered Fuel of the International Railway Fuel Association, presented before the annual convention at Chicago, May 15, 1916:

"Summing up the results that are being obtained in locomotive service, these may be stated as:

- "Smokeless, sparkless and cinderless operation.
- "Maintenance of maximum boiler pressure with a uniform

average variation of 3 lb. without loss through the pops.

"An increase of from 7½ to 15 per cent in boiler efficiency as compared with burning lump coal on grates.

RELATIVE VALUE OF COALS FOR STOKER FIRING

Basis per horse power hour, } Lb. coal	Gas		Soft or low volatile	
	Nut-pea-slack	Slack	Run-of-mine	Screenings
Relative lb. coal	3.88	4.23	4.32	5.17
Note: Nut-pea-slack—Coal passing through 1½-in. bar screen.	100.00	109.00	111.19	132.98
Slack—Coal passing through ¾-in. bar screen.				

CHEMICAL ANALYSES OF COALS

Class of coal	Gas		Soft or low volatile	
	Nut-pea-slack Fairmont	Slack Fairmont	Run-of-mine Somerset-Meyersdale.	Screenings
Moisture	1.23	1.57	.75	.81
Volatile matter	36.47	35.74	18.17	17.52
Fixed carbon	53.94	52.78	69.07	70.06
Ash	8.36	9.91	12.01	11.61
Total	100.00	100.00	100.00	100.00
Sulphur	2.59	3.30	3.33	2.31
B. T. U. (calculated)	13,100	12,900	13,800	13,870
B. T. U. (by calorimeter)	13,910	13,790	13,880	13,970

"Saving of from 14 to 30 per cent in fuel of equivalent heat value fired.

"Enlarged exhaust nozzle area resulting in greater draw-bar pull and smoother working of the locomotive.

"Elimination of ash pit delays, facilities and expense and reduction in time required for and ease in firing up.

"Maintenance of a relatively high degree of superheated steam.

"No accumulation of cinders, soot or ashes in superheater or boiler flues, smokebox or on superheater elements.

"No punishment of or overheating of firebox, new or old sheets, seams, rivets, patch-bolts, stays or flue beads.



D. Meadows, Treas.,  
Traveling Engineers' Association

"Elimination of arduous manual labor for building, cleaning and dumping fires and for firing.

"Avoids expense and annoyance for providing various sizes and kinds of fuels.

"Eliminates the necessity of front end and ash-pan inspection and for special fuels, firing tools and appliances for building fires and for stoking and cleaning fires.

"Equal provision with engineer for fireman to observe signals and track, thus reducing liability of accident.

"Your committee is of the opinion that the effectiveness and utility of fuel in pulverized form has been demonstrated from the past years' development and that the progress in the use of this method of stoking and burning bituminous and anthracite coals and lignites for generating power, heat and light on railways, will be quite marked from now on."

**Conclusions.**—The capacity of the power unit is largely dependent upon that of the boiler. With the increase in size of the locomotive, in the case of many new types the boiler has had to be enlarged to the extent of overreaching the limitations of hand firing, clearly indicating the necessity of introducing the fuel into the firebox by mechanical means. In fact, locomotives have within late years been constructed, the building of which would probably not have been attempted had not the practicability of this means of handling the fuel been established. There is little doubt that many

locomotives are in service the maximum capacity of which is not being obtained due to the limitations in connection with the ordinary methods of manual firing on grates.

The report was signed by: W. L. Robinson (B. & O.), chairman; E. Hartenstein (C. & A.); J. H. De Salis (N. Y. C.); M. J. McAndrew (M. C.) and E. A. Averill (Locomotive Feed Water Heater Company).

#### DISCUSSION

J. H. DeSallis, (N. Y. C.): On the Pennsylvania division of the New York Central there are 15 Mallet and one Consolidation locomotives equipped with stokers and superheaters. On the Mallet locomotives the nozzle has been increased from 6 in. to 7 in. in diameter. A low volatile slack coal is used in place of the run-of-mine which was used on the hand fired engines. However, there has been an increase in fuel consumption. The application of the stoker has entirely eliminated the requirement of a second fireman and the manual labor has been reduced to practically nothing, enabling the fireman to watch for signals. The grates are only shaken once over the 100-mile division and then not much. There has been some trouble experienced with foreign matter in the coal clogging the screw conveyor. The trouble with clinkers, which is found in hand fired engines, has been eliminated. The engine crews follow the engines more closely; they are in assigned service, and take more interest in the locomotive. Many firemen prefer these engines to local passenger runs. The smoke conditions have been materially improved and the steam pressure can be maintained better than on the hand fired engines. The train tonnage has been increased from 3,600 to 3,900 tons by the use of the stoker engines. Special men are assigned to care for these engines at the terminals.



W. O. Thompson, Secretary,  
Traveling Engineers' Association

F. P. Roesch, (E. P. & S. W.): On the El Paso & South Western there is a long pull of 117 miles with one per cent grade and another one per cent grade of 38 miles. In hot weather it has been found necessary to reduce the tonnage on the hand fired engines, but the stoker engines are loaded to full capacity. While more coal is used by the stoker engines it costs only \$2.10 per ton as compared with \$4.65 paid for the coal used on the hand fired engines. It is now planned to put the stokers on some passenger engines which are called upon to handle 14 steel cars over the long one per cent haul.

J. Keller, (L. V.): A stoker fired engine should be handled with as much care as the hand fired engine, as by forcing it unnecessarily hard there will be a waste of fuel. The coal should be fed in small quantities and should be controlled by regulating the speed of the apparatus. There is a need of a stoker for burning low volatile coal such as anthracite.

H. F. Henson, (N. & W.): It is quite necessary to carefully educate the firemen in the handling of the stoker and it requires intelligence to get the most out of an engine so fired. The stoker engines will handle more tonnage and get over the road more quickly than the hand fired engine and for that reason they are favorites with the transportation department.

W. W. Shelton, (C. & O.): Special men are assigned to

take care of the stoker engines. The cost for maintenance, including labor and lubrication, is 50 to 60 cents per 100 miles. With wet coal occasioned by heavy rains steam failures are liable to result. More trouble is experienced with clinkers than on hand fired engines with slack coal. The nozzles of the stoker engines have been increased from 6¼ in. to 6½ in. in diameter.

A. W. Willisie, (C. B. & Q.): The stoker engines on the Burlington use screenings passing through 2 in. round hole screens. It has been found that coal prepared on a round screen will be distributed better by the stoker than when it is prepared through the shaker bars. The stoker engine must be handled with care and the fire watched to see that proper distribution is being obtained.

Other speakers stated that after the men had once fired a stoker engine they would handle a hand fired engine more intelligently. Mr. Robinson in closing the discussion stated that from a six months' observation of Mikado engines on the same division it was found that the coal consumption per ton-mile varied as follows: Hand fired—100 per cent; stoker fired (assigned service)—110.8 per cent, and stoker fired (pooled service)—114.8 per cent.

#### ADDRESS BY MR. McMANAMY

Frank McManamy, chief inspector locomotive boilers, Interstate Commerce Commission, addressed the convention during the Wednesday morning session. He spoke chiefly on the locomotive inspection rules, calling attention to the fact that the railroad company was held responsible for the general design, construction and maintenance of the locomotive and tender. The daily inspection reports serve to protect the mechanical offices in charge of the equipment, especially where engines are ordered out before proper repairs have been made. The purpose of the law is to do what the motto of this association states, namely, "To improve the locomotive engine service of American railroads." The safe operation of the railways depends upon two things—good locomotives and competent men to operate them.

#### SMOKE ELIMINATION

The chairman of this committee recently read a book on the Steam Engine, the fifth edition of which was printed in 1836, in which the author stated that one of the chief barriers to cheap transportation was the enactment of a law by the English Parliament, forbidding the use of bituminous coal on locomotives because of the smoke nuisance. More real progress in smoke abatement has been made in this country within the last five years than had been made in 50 years previous to this period. This great and permanent advancement was obtained through the executive heads of the railroads taking hold of the question. To some extent this was forced on them by legislative action, which in many cases was unreasonable. The willingness of the city authorities to be fair with the railroads has resulted in the managements of the roads spending large amounts of money on experiments, education of the men and supervision.

The smoke problem is a question of perfect combustion. The nearer we come to it the nearer we are to smokeless operation, but when the varying conditions under which a locomotive is operated are considered it is not an easy matter. At times it is necessary to burn as high as 150 lb. of coal per square foot of grate surface per hour, a condition that few combustion engineers ever consider in advocating smokeless operation. We will admit these are extreme conditions and the facts are that the complaints of smoke violations come more frequently from more favorable conditions where the violation could have been avoided with proper care by the engine crews. Of course there are cases where the engine crews are not responsible. One of these is where the power is in poor condition, but the great majority of these cases were caused by carelessness of the engine crews. The men

are educated to regulate the fire so that only the minimum amount of smoke will be made and the great majority never give cause for complaint. But we find certain men in all walks of life who do just enough to get by. These are the men that one has to contend with in handling the smoke problem. This same class is responsible for the railroads of Chicago spending \$65,000 a year for supervision and proportionate amounts in other cities.

There is no question but that seniority as conducted today, encourages this class of men and is an injustice to the man who takes a pride in educating himself and doing things the best he knows how. On the other hand those of us who are old enough to have worked under conditions existing before seniority became general, still believe it to be a lesser evil than favoritism. The main objection to seniority is that it has no incentive for a man to do things as they should be done. One thing that could be done without affecting senior rights would be to make a record of the men at stated periods. This would be along the lines followed some years ago on many roads when each engineer received an individual performance sheet monthly, showing the number of miles made by his engine, the cost for fuel, oil and repairs, the engineers' and firemen's wages, wipers' wages, average cost per hundred tons per mile and all details pertaining to the operation and maintenance of their engine. It would in our opinion result in saving the present cost of supervision needed to keep smoke elimination within the limits which are required.

Human element enters largely into the matter of smoke prevention, regardless of any and all known mechanical devices. The stoker fired engine when handled intelligently is practically smokeless as well as being a fuel saver when size of engine and tonnage rating is considered. Perhaps the nearest approach to smoke elimination in the operation of locomotives will come with the use of powdered coal, now being experimented with on several railroads. The use of powdered coal will afford a more perfect combustion of the fuel than is otherwise possible, which will of course be a great advantage, but in spite of that fact there will ever be

black smoke and 30 seconds for dark gray is recorded. No smoke prevention devices are used except the brick arch. The placing of the smoke consumers on an engine admits that it is impossible to have smokeless firing. The stoker engines give the greatest trouble.

E. F. Boyle, (Sunset Central): At the bottom of the work reports the question is asked as to whether the engine steams poorly or if it smokes. In case they do they are examined carefully and if they are found in a satisfactory condition the engine crews are called upon to explain. Oil burning locomotives can smoke as badly as any coal burner and they must be carefully watched.

W. H. Corbett, (M. C.): In case of a second violation the offender is given a suspended sentence of 5 days which is held over him for a year. At the end of that time if he has an otherwise clean record it is removed. The brick arch and the steam jet smoke consumer used in the vicinity of Chicago give excellent results.

C. W. Corning, (C. & N. W.): When firing up a cold engine, by placing the coal on the grates and covering it with kindling such as edgings from the mill and igniting it with waste saturated with coal oil a fire can be started with but very little smoke. The fire up man can also handle more engines in this way than he could otherwise. The engines must be maintained in good condition to insure smokeless operation.

[NOTE.—The report of the remainder of the convention proceedings will be published in the December issue.—Editor.]

## POWDERED COAL IN ENGINE SERVICE\*

BY C. W. CORNING

Chief Service Inspector, Chicago & North Western

Powdered coal has been used successfully and rather extensively for many years in cement and metallurgical furnaces, but its use for making steam has been limited, due, perhaps, to the lack of practical development. A cubic inch of solid coal exposes only 6 sq. in. for absorp-



Chicago & North Western Pulverized Fuel Burning Locomotive

a need of the faithful and intelligent co-operation of the engine crews. This latter factor really represents the most difficult feature of the whole problem.

The report was signed by Martin Whelan, chairman.

### DISCUSSION

W. L. Robinson, (B. & O.): It is not necessary to discipline the men for bad smoke performance. Records should be kept of each offence and explanations called for. Let the men know frequently where they stand and if impossible to get a good performance they should be transferred to other districts. Close supervision is necessary. In Washington, D. C., every smoke emission lasting more than 10 seconds for

and liberation of heat; a cubic inch of powdered coal exposes from 20 to 25 sq. ft., which enables a more uniform gas production from the volatile matter in the coal, and a more prompt and perfect intermingling of the gas and air, thereby improving combustion and reducing smoke.

In July, 1915, the Chicago & North Western equipped one of its Atlantic type passenger locomotives for burning pulverized coal. This engine was placed in service August 8, 1915, and was given severe tests in heavy through and suburban passenger service as well as on transfer runs, and has never failed to produce the desired results. The physical

\*Presented at the recent convention of the Smoke Prevention Association, held in St. Louis.

characteristics of this locomotive are shown in the table:

Total weight of engine.....	180,000 lb.
Weight on driving wheels.....	96,000 lb.
Tractive effort.....	21,850 lb.
Cylinders, diameter and stroke.....	20 in. by 26 in.
Driving wheels, diameter.....	81 in.
Size of firebox.....	108 $\frac{1}{2}$ in. by 65 $\frac{1}{2}$ in.
Firebox heating surface.....	170.7 sq. ft.
Total heating surface.....	2,770.7 sq. ft.
Superheating surface.....	428 sq. ft.
Steam pressure.....	185 lb.

The equipment installed in this engine was obtained from the Locomotive Pulverized Fuel Company, New York, and was the second installation of its kind in this country. On this locomotive, however, the feeding mechanism and fan blowers are operated or are driven by electric motors which receive their electrical energy from a Curtis turbo-generator located on the front of the engine, which it should be remembered is only a temporary expedient. Since this installation a variable speed steam turbine has been developed for driving this feeding mechanism which is more simple in operation and less complicated in construction and more economical.

The powdered coal is contained in an enclosed tank on the tender. In the bottom of this tank there are three screw conveyors, which bring the fuel to the feeders where it commingles with the air from the fan and is blown through the flexible conduits into the nozzles and from there to the three burners which enter the firebox just under the mud-ring.

being conveniently located so that it is very seldom necessary for the fireman to get off the seat, where he can keep a constant lookout for signals.

From the burner outlets the fuel and air passes into the gasifying chamber, which is formed by a primary arch located just over the outlet of the burners, and from there into the combustion chamber. The products of combustion pass forward and up and along the bottom of the brick arch, thence over the top and along the crown sheet into the tubes. This brick arch, however, is the standard locomotive brick arch set close against the flue sheet and extending one brick



Locking Into the Cab of the North Western Locomotive

From the flexible conduits the coal and air mixture passes the mixing chambers to the burners where additional air is automatically admitted by induction according to the amount of fuel being used, before it reaches the burner outlets. The dampers in the mixing chambers are under the direct control of the fireman and are used to adjust the volume and velocity of the induced air supplied at this point when the engine is using steam, and to shut off the air supply when standing or drifting. The speed of the screw conveyors in the tank also is controlled by the fireman, all the controlling apparatus

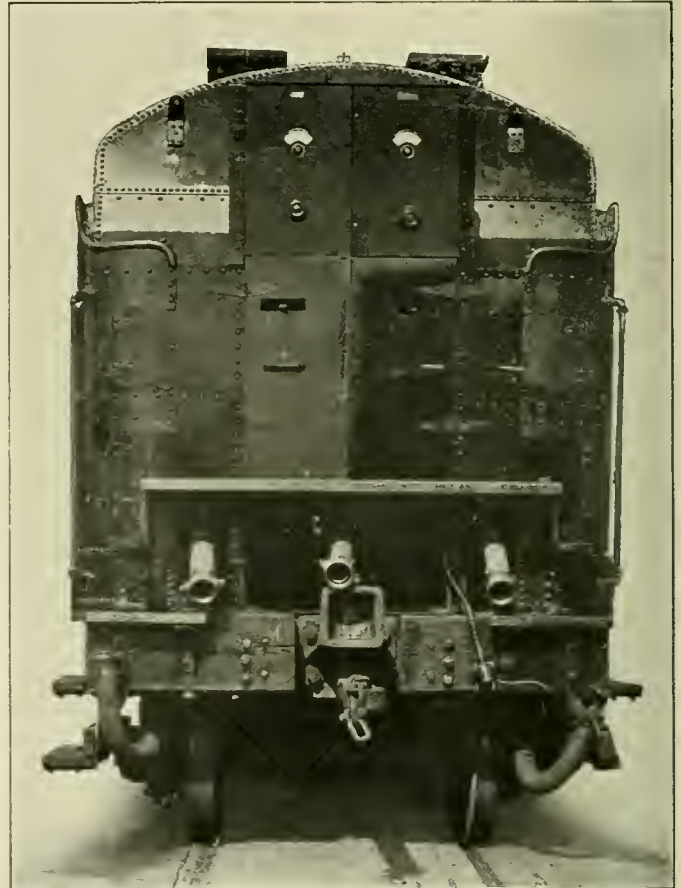

Front End of the Tender of the North Western Locomotive

higher than those used in the same type of engine hand fired. This increases the flame travel and the evaporation efficiency of the back head of the firebox.

It was expected that some difficulty would be experienced in the life of the brick work as well as from a firebox with half side sheets, but due to the action of the flames, which have a rolling rather than a blast action, no trouble has been experienced, in fact, it has been conceded by the boiler-makers that the firebox is in better condition than it would have been if placed in hand-fired service, because of the even temperature maintained and no cooling effects from opening the fire door.

The use of this apparatus has increased the capacity under which this boiler may be operated to the extent of three 4-in. safety valves which are required to properly relieve the boiler, where three 3-in. safety valves is the standard for this type of engine under hand-fired conditions. It is possible, also, to increase the size of the nozzle, thereby reducing back pressure and wear and tear on machinery, and making it a smarter engine.

A most important factor is to have the coal properly prepared. The best results cannot be obtained unless the pulverized coal contains not to exceed one per cent of



moisture, and is milled so that 85 per cent of the total will pass through a 200-mesh screen, and 95 per cent. of the total through a 100-mesh screen.

The control of the fire is such that while standing at stations it can be extinguished entirely to prevent waste of steam through the pops. On several occasions where it was necessary to wait from 15 to 45 minutes in terminal stations before leaving time the fire was always extinguished, and then relighted from 3 to 5 minutes before conductor gave signal to start.

The firing up of this locomotive is very simple. In firing up the locomotive in the roundhouse all that is necessary is to apply about a pound of lighted waste which has been



Looking Toward the Back of the Firebox, Showing the Primary Arch and the Burners

saturated with fuel oil to the outlet of one of the burners, then start the feeding mechanism and the coal will ignite. A blower must be used at all times when fire is burning and throttle is closed in order to induce the combustible mixture into the furnace. The emission of smoke is practically negligible. In firing up an engine which is cold, and roundhouse steam is being used for the stack blower as well as to drive the turbine, the smoke reading has read one-half of one per cent according to the Ringelmann chart for from 5 to 10 minutes. As the brick work in the firebox becomes heated this gradually disappears. When engine is being worked on the road pulling a train the operation is absolutely smokeless. There are no sparks nor cinders emitted from the stack at any time.

A very noticeable feature in the initial firing up process of this engine is not alone the ease with which this can be accomplished, but also the small amount of coal consumed and the rapidity with which the steam can be raised from cold water, which is from 50 to 60 minutes. Several tests show that 750 lb. of coal is the average amount used to obtain full boiler pressure as against 1,700 lb. of coal as used on a hand-fired engine of the same class. However, it must be remembered, in comparison, that the hand-fired engine has a fuel bed still on the grates which possesses considerable heat energy. On the other hand, the pulverized coal engine has much more brick work in which a large amount of heat will be stored during the firing-up process.

Perhaps this feature of firing-up, especially to railroad men who have to do with the firing-up of locomotives and getting them out on their various schedules, will be most interesting. It is possible to fire-up this type of locomotive, raising the boiler pressure to the maximum, then shutting the fire off by stopping the supply of fuel, and then allowing the engine to stand for several hours without any further attention. All that is necessary is to relight the fire about 5

minutes before engine is due to back out of the house, providing boiler pressure has not fallen below 60 lb. In fact, on several occasions the engine has stood 8 hours in the roundhouse and fired up again with its own steam.

Among the many benefits enumerated, the elimination of the ash pit appeals to the smoke inspector very strongly, there being no necessity for cleaning fires, as the only non-combustible residue to be disposed of is the slag which is of a glassy nature and composed principally of silica, iron and aluminum, this being of a brittle, self-dumping and easily removable nature when solidified. The amount of slag as compared with the ash from the hand-fired engine is 4 per cent in the former and 15 per cent in the latter.

*Characteristics of Fuel for Powdering.*—It has generally been thought that for the burning of solid fuels in powdered form in suspension, a bituminous coal of less than 30 per cent volatile matter could not be used with satisfactory results. As the object is to convert the powdered fuel into a gaseous state as early during the process of combustion as practicable, this characteristic as regards the desired proportion of volatile matter, while desirable, has not been found to be essential. Satisfactory results are now being obtained in locomotive practice from semi-bituminous coals analyzing as low as 21 per cent volatile and having 15 per cent ash and moisture, and with mixtures of 40 per cent anthracite having 7 per cent volatile, and of 60 per cent bituminous having 24 per cent volatile, making an average of about 17 per cent volatile.

With pulverized coal it is entirely practicable with inferior grades of bituminous and sub-bituminous coals, such as mine refuse and sweepings, run of mine screenings, slaked



Looking Forward in the Firebox of the Pulverized Fuel Locomotive

coal and lignite, to operate with the results previously described. During the past year the fuels described in the following table have been successfully used while engine was performing regular service:

Contents	Unwashed Screenings		
	Illinois Bituminous	Kentucky Bituminous	North Dakota Lignite
Moisture (per cent).....	From 3.18 to 15.36	1.9 to 2.8	1.8
Volatile (per cent).....	Average 34.9	30.0	47.25
Fixed Carbon (per cent)...	Average 47.0	54.0	40.91
Ash (per cent).....	Average 19.0	8.0	9.32
Sulphur (per cent).....	Average 1.70	0.79	0.79
B. t. u. ....	From 10,720 to 12,409	13,964	10,960
Fineness (per cent).....			
Through 100-Mesh.....	From 90.7 to 99.69	93.0%	98.
Through 200-Mesh.....	From 71.45 to 97.06	83.0%	95.9

During the period of experimentation, the most interesting feature was the tests that were made in April of this year, between Chicago and Milwaukee, a distance of 85 miles, comparing the pulverized coal engine burning pulverized

mine run Kentucky screenings, and another engine of the same type, hand fired, burning Kentucky lump coal. Both engines were equipped with superheaters, and a dynamometer car was used in all the tests. The following table gives the average results of these tests:

Locomotive number.....	128	127
Method of firing.....	Pulverized fuel	Hand
Kind of coal used.....	Ky. screenings	Ky. lump
Elapsed time (hours).....	4.0276	4.0958
Running time (hours).....	3.8687	3.9688
Tonnage.....	291	278
Number of cars.....	5.8	5.5
Mileage.....	170.79	170.75
Average drawbar pull (pounds).....	2,711	2,527
Horsepower per hour.....	319.5	290.3
Coal used (tons), running.....	3.815	3.783
Water used (gallons), running.....	8,381	7,350
Coal per hp. hr. (pounds).....	6.17	6.57
Water per hp. hr. (pounds).....	56.48	54.14
Water evaporated per lb. coal (pounds).....	9.15	8.09
Coal used for firing up† (tons).....	1.569	2.775
Total coal used (tons).....	5.384	6.558

†This item includes, in addition to firing up, the amount of coal used in taking the engine to and from the train and the amount used by the engines during the "dead" time.

From observations taken the gas analyses showed 13 per cent CO<sub>2</sub> when the coal was fired at the relatively low rate of about 3,000 lb. per hour, and is increased to 16 per cent CO<sub>2</sub> as the rate of combustion increases. At the same time the smoke box temperatures averaged 450 deg. F.

In conclusion, the results that are being obtained from this locomotive in service may be summarized as follows:

*First*—Smokeless, sparkless and cinderless operation.

*Second*—Saving of from 15 per cent to 30 per cent in fuel of equivalent heat value fired.

*Third*—The elimination of ash pits, their delays and expense, and the arduous labor of dumping, cleaning and building new fires.

*Fourth*—Enlarged exhaust nozzle resulting in smoother working engine, and increasing the efficiency of the boiler.

*Fifth*—Ability to maintain maximum boiler pressure under all working conditions.

*Sixth*—No special fuel required for firing up, thereby eliminating the enormous pile of wood or coke necessary for ordinary methods.

*Seventh*—The ability to make use of inferior grades of coal which cannot be utilized to good advantage otherwise.

*Eighth*—The firing of the boiler is entirely automatic. No fuel whatever is supplied to the furnace by hand shoveling. Less physical requirements in firing, as the fireman is relieved from manual exertion. To use the railroad colloquial of the day, it is not necessary to "choke the No. 6, throw in a slug, get up on the seat box and ride the fire out" while the Smoke Inspector is holding the stop watch and wondering whether or not the smoke will ever clear up.

**THE POWER OF A HORSE LESS THAN A HORSEPOWER.**—The power exerted by a horse when plowing and traveling 1.8 mile per hr. and pulling about 150 lb. amounts to 0.72 of the so-called mechanical horsepower. Dynamometer tests have shown as high as 200-lb. pull at the rate of 1.8 miles per hr. This amounts to 0.96 hp. It is therefore evident that when Watt determined the mechanical equivalent of a horsepower he selected a better-than-average horse. —*Power.*

**THE PROPER TOOL FOR TRUING GRINDING WHEELS.**—The diamond tool is the most efficient means for truing the face of grinding wheels for precision work so far discovered. The reasons are: Diamonds or bortz are harder than the wheel to be trued; they are obtainable in sufficient quantities to meet the demand; they provide a means of making the wheel a true cylinder and at the same time provide any kind of wheel service desired; they lend themselves to a reasonably easy setting and are conveniently applied to the work, and the waste of the wheel is negligible.—*Grits and Grinds.*

## TRIANGLE FOR USE IN TRACING

BY HUGH G. BOUTELL

The accompanying sketch shows a triangle which was developed by the writer and has proved particularly useful in tracing work where speed is essential. It is made up of two 45-deg. triangles, one enough larger than the other so that it projects about 1/4 in. on all three sides. The two triangles are held together with Le Page's glue.

In tracing, considerable care is required to slide an ordi-

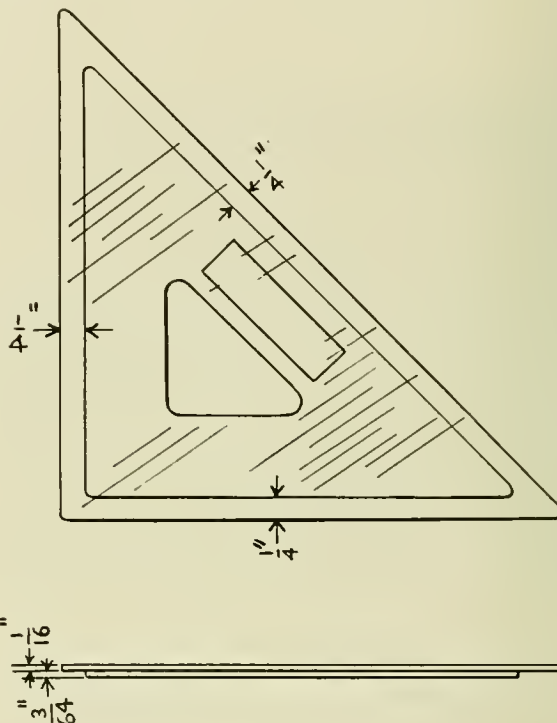

Convenient Triangle for Use in Tracing

nary triangle up to a freshly inked line without touching the wet ink. In the double triangle, the 1/4-in. projection of the upper part obviates the danger of blotting the tracing. It also allows greater lateral freedom of the ruling pen and makes possible better matching up of straight lines and curves.

**RAILROAD COAL CONSUMPTION.**—The railroads of the United States used 128,200,000 net tons of coal in 1915. This amounts to about 24 per cent of the total output. The bituminous mines furnished 122,000,000 tons, which is 28 per cent of their production, and the Pennsylvania hard coal regions supplied 6,200,000 tons, approximately 7 per cent of the total production.

**SIZE OF STEAM PIPES FOR RECIPROCATING ENGINES.**—Size of steam pipes for reciprocating engines operating at full stroke may be determined by comparing the diameter of the cylinder squared and multiplied by the piston speed per minute with the diameter, assumed, for the steam pipe squared and multiplied by the desired steam velocity. Example: The pipe size for a 20-in. cylinder and the piston operating at 600 ft. per min. is between 6 and 6.5 for a steam velocity of 6,000 ft. per min., since  $20 \times 20 = 400 \times 600 = 240,000$ , while for comparison  $6 \times 6 = 36 \times 6,000 = 216,000$  and  $6.5 \times 6.5 = 42.25 \times 6,000 = 253,500$ . The 6-in. pipe would require a steam velocity of  $240,000 \div 36 = 6,666$  ft. per min., while in the 6.5-in. pipe the steam velocity would be only  $240,000 \div 42.25 = 3,857$  ft. per min. —*Power.*

# Car Department

## THOUGHTS SUGGESTED BY INDIAN-APOLIS CONVENTION

The following thoughts were not necessarily expressed on the floor of the convention, but were suggested by some one or more of its varied activities. Editorial comments of special interest in this connection will be found on pages 549 and 550 under the following heads: "Higher Officers, Attention"; "Uniform Interpretation of Interchange Rules"; "Loss and Damage to Freight"; and "Car Department Apprentice Problem."

### What Manner of Men Are They?

It was my first experience in attending a convention of the Chief Interchange Car Inspectors' and Car Foremen's Association. Naturally the question foremost in my mind was as to how it would compare with similar meetings of the other railway mechanical associations. How would its members check up individually and collectively with those, say, of the General Foremen's or the Master Blacksmiths' Associations? How would they express themselves in the discussion of complicated questions? With what degree of executive and business ability would the proceedings be carried on?

Briefly, the gathering was large, the attendance good and consistent at the two sessions each day; the members, clean-cut in appearance and good at expressing themselves on their feet; the meeting notable because of the comparatively large number of the younger men in attendance—on the whole one could not but be favorably impressed with the appearance of these men and the manner in which they conducted themselves.

Car inspectors and car foremen! Officers in the mechanical and operating departments have sometimes elbowed them aside as if they were not worthy of or capable of the bigger things in the mechanical department. Times have changed. With the more severe and exacting conditions it has become apparent that just as high and possibly a higher degree of executive and technical ability is required to solve car department problems and handle the labor question as in the locomotive and operating departments. Indeed, in the struggle to hold down the operating ratio in the face of higher labor and material costs, increased taxes and greater expense entailed by state and federal regulation, it is quite probable that greater possibilities for increased efficiency lie in this field than in the other departments.

Sizing up roughly the men in attendance at this convention and comparing them with the personnel of the other associations it would appear that the men are available for this great task provided they are given proper encouragement—and the word "encouragement" is used in a large sense. Their suggestions and recommendations should be given a respectful hearing, and the fact that they are on the firing line and, if capable, are thoroughly familiar with the detail problems, should give weight to their recommendations. The higher officers, or the interests they represent, will be liable to pay dearly for carelessness or indifference to the opinions and suggestions of these men, and by the same token the car department officers and foremen should be firm and insistent

in following up such recommendations as they may make, once they are sure they are in the right.

### Big Possibilities Ahead

Heretofore the association has confined its work to the consideration of the interchange rules. Because of the probability of fewer changes in the rules in each succeeding year, the executive committee of the association decided last February to widen its activities and give more and more attention to car department problems other than those concerned strictly with the interchange rules. A study of the convention proceedings will show with what great success the new venture met, in spite of the limited amount of time available for getting it started. A most important factor in this success was the prize competition on car department apprenticeship. The association is under obligations to the donor of the prizes for following it up with a similar offer for the 1917 convention. Now that the ice is broken and the association has grown to a larger size, it is to be hoped that a greater number will take part in the second competition. And this is said with no reflection on the number which took part in the first one. It was splendid for a starter. The prizes are well worth striving for; the financial return, however, is only a small part of the reward to those who take part. The prestige that will come to the winners and the greater respect in which they will be held by their comrades is of far greater importance. Those who do not win will be amply rewarded by the effort which they will make. It will crystallize their ideas and start them at work in the local solution of the biggest problem which today confronts the car or any other department of a railroad.

### Stumbling Blocks

The use of the word "reasonable" without qualification in legal enactments has cost millions in litigation. In a smaller way, the expression "unfair usage" in some of the interchange rules and the wording of paragraph 2 in Rule 4 are about as troublesome. The latter paragraph reads: "Defect cards shall not be required for any damage that is so slight that no repairs are necessary." Because the inspectors fear that they will be criticised, many defect cards are applied that under this rule are not required. The delays and useless expenditure of time and money thus caused amount to a large item on many of the roads. This rule stirred up far more discussion than any other; the final recommendations of the convention as to its application will be found in the report of the convention proceedings.

### Saving Time in Meetings

While the work of the convention was handled in a most expeditious manner, it may be well to see if there is not some way of still further conserving the limited amount of time which is available for the meeting. This is necessary because there will always be more problems requiring discussion than can be handled in a three days' convention, and it is hardly wise to try to hold the members for a longer time. An important factor in conserving the time this year was that the officers were always on hand and in place well in advance of the announced time of the meet-

ing and the gavel came down with a thud on the exact minute. It would seem advisable for the officers or the executive committee to appoint some member or a small committee in advance to study the changes in rules and be prepared to state concisely and clearly the changes which have been made in each rule so that the complete reading of the rule will be unnecessary. In addition, each member should be fully prepared in advance to ask questions concerning its application or to make suggestions. Considerable time was lost on several occasions because members asked questions apparently on the spur of the moment and without any real thought or study as to the special application of the rule. This is not fair to the rest of the members.

### Protecting the Stockholders

In welcoming the convention to Indianapolis the corporation counsel emphasized the importance of the car inspector's and car foreman's work from the standpoint of protecting the traveling public from danger. And surely this cannot be overestimated. Of first importance also is his work in protecting the railroad from loss due to accidents and losses in operation caused by delays due to defective equipment; then, too, there is the large item of loss and damage to freight. A further item of no small importance which has developed rapidly in recent years was expressed by one of the members in the words "protecting the directorships against penalties assessed for the infringement of the laws." Safety appliance legislation and other acts have added not a little to the responsibilities and duties of the car inspector. Likewise it requires greater responsibility on the part of each road in selecting and training the men better to discharge these duties. Unfortunately some roads do not seem to have awakened to their full responsibilities in this direction.

### WORK OF THE ASSOCIATION OF MANUFACTURERS OF CHILLED CAR WHEELS\*

The work of our association during the past year has been based upon the recommendations made to the Master Car Builders' Wheel Committee during the year of 1914. Our recommendations were substantially as follows: First—an increase in the weights of the 625 and 725 lb. M. C. B. wheel; second—an 850-lb. wheel for cars of 140,000 lb. capacity; third—a flange for the 850-lb. wheel for use under the 70-ton cars with as much of an increase as would be acceptable to the American Railway Engineering Association.

Since our organization in the year 1909, we have steadfastly maintained that the varied service in the 60,000-lb. capacity class of cars made it imperative that the weight of the wheel should either be increased to meet the maximum conditions of service, or that we should have two standards in this class. The variation in service arises from the variations in the light weight of cars of 60,000-lb. capacity, and as the standard of operation is to brake the cars 60 per cent of their light weight it must follow that any class of cars in which there is 100 per cent variation in light weight, which is common in the 60,000-lb. class, cannot with safety carry the same weight of wheel. But this is what the manufacturers have been required to do.

The standard wheel specified for 60,000-lb. capacity cars weighs 625 lb. and the light weights of the cars vary from 20,000 lb. to 53,000 lb.

Our association recommended that the weight of the wheel be increased to 675 lb. which would provide a standard wheel to meet the maximum conditions of service as to load and brake, and in asking for an increase in weight of the 625-lb. and 725-lb. M. C. B. standard wheels, we were not actuated by commercial considerations.

It is estimated that there are 2,500,000 chilled iron wheel renewals annually and if the weights should be increased 50 lb. each the additional metal to be purchased would approximate 62,500 tons, providing all the renewals required an increase. This is by no means the case, because many of the prominent railroads in the country, representing over a fourth of all the cars in use, are already introducing advanced standards and are using wheels much heavier than the present M. C. B. standards. The heaviest 725-lb. M. C. B. standard chilled iron wheel for 50-ton cars is lighter than the rolled steel wheel and there is no good reason why the chilled iron wheel should be so limited in weight.

Our association has made a very satisfactory arrangement with the University of Illinois through Dean W. F. M. Goss, in which it is agreed "that the University experiment station will undertake an investigation concerning the stresses and behavior of chilled iron car wheels." In submitting a draft of this arrangement to the president of the University of Illinois, Dean Goss said in part as follows: "The importance of securing proper design and proper methods of manufacture for such wheels may be judged by the fact that there are now in operation in the country approximately 20,000,000 freight car wheels, and the demand for renewals alone involves the manufacture of 2,500,000 chilled iron car wheels per year. With these facts in mind, the Association of Manufacturers of Chilled Iron Wheels has agreed to cooperate with the engineering experiment station in a study of the questions fundamental to the design of such wheel."

### PREVENTING HOT BOXES ON THE NEW HAVEN

Fewer hot boxes on the cars of the New York, New Haven & Hartford are being reported than at any time during recent years. During the week ending September 9, there were only 18 hot boxes on passenger cars reported on the entire New Haven road, whereas in the corresponding week last year there were 40 reported. The reduction each week in comparison with the figures for a year ago averages over 50 per cent. The improvement is due in large measure to a more rigid inspection of cars, journals and journal bearings.

The boxes are inspected at all terminals upon arrival of incoming trains and before departure of outgoing trains, special men being appointed for this task. Before use the waste is soaked for 48 hours, and allowed to drain for 48 hours to remove all excess oil. It is packed in the journal box in three distinct parts. The first is a roll which is packed at the back of the box to prevent dust from entering the box from the rear, and to keep the second or center packing in position. This second packing supplies the oil that continually flows between the journal and the bearing. It is placed in the box fairly loosely and on the underside of the journal. The revolving journal draws the oil from the waste upwards, but does not move the waste itself. The third and last part is a roll that is placed in the front of the box to keep the second packing in place and to prevent dust from reaching the journal.

Besides the frequent inspections during the journey of a train, the crew utilizes every opportunity while the train is in motion and at stations, to look to see that no smoke is coming from any of the boxes. Upon arriving at destination, journal boxes are inspected for heated journals and those found unduly warm are marked with chalk as an indication to car repairers that the journal has given trouble and requires attention.

**HIGH CONDENSER VACUUM.**—Reducing vacuum below 26 in. does not materially increase the efficiency of reciprocating engines, but in turbines there is ample space or passage for large volumes of steam and the lower condenser pressure can be fully utilized.—*Power*.

\*Extracts from the address of President G. W. Lyndon at the annual meeting of the association in New York, October 17, 1916.

# CAR INSPECTORS' AND FOREMEN'S MEETING

## The Rules of Interchange Discussed; First Prize Article on Car Department Apprenticeship

THE eighteenth annual convention of the Chief Interchange Car Inspectors' and Car Foremen's Association was held at the Hotel Severin, Indianapolis, Ind., October 3, 4 and 5, President A. Kipp, general car inspector, New York, Ontario & Western, presiding. The meeting was opened with prayer by Rev. Frank S. Wicks, pastor of All-Souls Church. The convention was welcomed to the city by William A. Pickens, corporation counsel of the city. T. J. O'Donnell, of Buffalo, responded to the address of welcome. During the convention the association was addressed by F. W. Brazier, superintendent rolling stock, New York Central East; W. O. Thompson, superintendent rolling stock, New York Central West; A. La Mar, master mechanic, Pennsylvania Lines, and Roy V. Wright, editor, *Railway Mechanical Engineer*.

Corporation Counsel Pickens said in part: I doubt whether the people generally, and especially the traveling public, appreciate the importance of your convention. Those of us who are dependent upon the railways to carry us about the country realize that upon your work depends the safety of our lives. Necessarily you become a set of men who feel the responsibility of your work, and it is well that you hold these conventions to get an interchange of ideas as to how that work may best be performed. No man possesses the wisdom equal to the combined wisdom of his profession and it is to the benefit of the whole country that you hold these conventions and better learn to perform your duties for the advantage of all the traveling public.

### PRESIDENT KIPP'S ADDRESS

It gives me great pleasure to welcome the members and their friends to this the eighteenth annual convention of the Chief Interchange Car Inspectors and Car Foremen's Association of America. Our employers, the railroads, which I feel recognize the work that is being accomplished by our association, have made it possible for us to attend and it is sincerely hoped that all will derive profit from the discussions. Principally our meeting is for the purpose of discussing the M. C. B. rules of interchange. We are, however, all familiar with the great problems that are confronting the railroads today and the conditions we will have to face in the future as a result of the stir in certain quarters which without doubt will affect all branches of railroad work. All work must be done thoroughly by each individual as a portion of his effort to assist our employers in solving some of these problems and there is no better way for us to bring this about than to get a clear and concise understanding of the M. C. B. rules and then carry it into practice.

We are all familiar with the equipment in use today, some of it having received betterments in more or less different forms made necessary, in part, by the use of heavier power, but we still have cars that have not been improved and in such cases our inspectors must be very careful in their in-

spection, using good judgment in order that these cars may be handled safely, without delays, damage to contents or criticism by the operating department. I am aware that in the past year we have been seriously handicapped because of labor conditions and slow delivery of materials and while we are not responsible for this situation it demands concentrated effort and work on the part of all of us. What is needed to alleviate some of the present day problems is a greater uniformity of equipment on our freight cars and while this subject is a general one it deserves considerable thought and should be encouraged. You can draw your own conclusions as to the time and money that would be saved by this practice.

D. R. MacBain, in his presidential address to the Master Car Builders' Association, recommended that that association consider the advisability of making the owners of cars assume all responsibility for the damage and repairs to them. This

is an excellent idea, but it involves again the question of equipment of uniform construction, for otherwise it would be necessary for the railroads to carry a larger stock of material in order to make prompt repairs.

The establishment of the office of chief joint car inspector has done a great deal toward improvement in the interchange of cars, and the car inspector himself is a vital factor in the entire plan. Much has been said and written as to the requirements of a good car inspector and much more could be added. In brief, he should be a practical man with a thorough knowledge of car construction, the M. C. B. rules and their proper interpretation, the M. C. B. loading rules, and the safety appliance laws; he should be a man of good judgment and able to apply the knowledge he has obtained in the performance of his work. He should have close relationship with the general inspectors in order that

he make more judicious inspections and better understand the M. C. B. rules.

I am enthusiastic over the good I feel this association has done for the inspector and I wish every inspector could attend our meetings; surely he would go home with an added interest in his work. It behooves each one of us to carry back to our men the ideas and opinions expressed here. The M. C. B. rules of interchange are complicated and require considerable thought and it appears to me that it might be a good plan to have the references and exceptions follow each particular rule, also to combine the M. C. B. rules of interchange, the M. C. B. loading rules and the safety appliance laws, in one book under the heading of the M. C. B. code of rules. By doing this the inspector would be saved a lot of time and would get a better interpretation of the rules.

We have this year broadened the scope of the membership to include car inspectors, M. C. B. bill clerks or anyone actively engaged in the work of the car department. In addition to this the association will consider, for the first time,



A. Kipp, President,  
Chief Interchange Car Inspectors' and  
Car Foremen's Association

other subjects not relating particularly to the M. C. B. rules. This brings the association to the task of studying the car department problem in the larger sense and will make the association of greater service to the roads of the country. A very important subject that should be considered is car lubrication.

**ADDRESS OF MR. BRAZIER**

F. W. Brazier, superintendent rolling stock, New York Central East, said in part: The Interchange Car Inspectors' the Car Foremen's Association of America was organized for the purpose of obtaining a thorough understanding of the rules of interchange. The association and the men composing it have more to do with the safety of the railroads than any other branch.

There is no body of men in the country that I take a greater interest in than the young men that are connected with the rolling stock department and who try to help themselves. About 40 years ago I

started in as a car repairer and in those days this class of men was very different from the present type. They had to be full fledged carpenters and have a kit of tools. A car repairer also did everything on a car from the trucks up, no laborers being provided.

The car department is recognized on the New York Central as a big, important department. Over \$14,000,000 a year is spent in this department on the New York Central proper. However, there does not seem to be the chance for promotion that there is in the locomotive department, from the fact that the motive power department pays a higher rate for its employees and for supervision. This condition is being looked into, I think, very generally over the country, and is arousing a great deal of interest among different officials who realize the power the general foreman or any other foreman of the car department has to spend or save money. In fact, they have their hands on the railroads' pocket books, and I believe that some action should be taken on different roads to make the inducements as attractive in the car department as in any other department. We have many young men who decline to take an apprenticeship in the car department because they find they cannot make the rates of pay that they can in other departments.

At a recent meeting of the Roadmasters' Association the following statement was made: We have made an investigation of 25,550 cases of derailment and the causes were as follows:

Equipment Department .....	32.5
Operation .....	51.9
Unavoidable .....	11.4
Maintenance .....	4.2

The point I want to convey to you is the importance of inspection. You have this in your own hands better than any organization there is in the railroad service, and you should keep before your officials the importance of closer inspection of the equipment. We overlook many of the little things which lead to derailment. Among them are the absence of spring cotters in brake hanger bolts and brake connections which cause the brake hanger pins or brake beams to drop to the rail and cause derailment. There is no need of putting a nail in place of a spring cotter. If you will



W. J. Stoll, Vice-Pres.,  
Chief Interchange Car Inspectors'  
and Car Foremen's Association

look into the percentage of derailments caused by brake beam failures you will be greatly surprised. Consequently there is no subject that you can take up that will result in more good to the railroads than better maintenance of equipment. As I stated at the M. C. B. convention, on all bolts in trucks and brake connections there should be some approved kind of nut lock or spring cotter so that the bolts and brake pins cannot get out of place.

I recently attended a "Giant" ball game. I watched that wonderful infield and the secret of the success was that they pulled together. It is just so in railroad work; we are made up of different departments, the car department is only one of the large number, but we have all got to work together to bring about the right co-operation. You know when a car inspector decides that a car is unsafe to move, no official would dare to run it. Consequently it is up to you gentlemen to keep before your officials the importance of the little things that should be maintained on cars to save derailments and save delays of holding up the cars for extensive repairs.

In closing I want to say one thing more about your convention and what your discussions will mean. Your interpretation of the rules, coming as you do from the North, South, East and West, will be the means of your having a better understanding of the rules, so there will be less friction and a better movement of the freight, which at the present time, with the terminal facilities we have, is exceedingly important.

**ADDRESS OF MR. THOMPSON**

W. O. Thompson, superintendent rolling stock, New York Central West, said in part: I never had the pleasure of attending one of your meetings before, but have heard a good deal about them and have always been very much interested, to the extent that I send, I believe, as many representatives as any other road in the country and I find that allowing our representatives to be here proves a good investment for the company. The car department of the railroads has improved wonderfully during the past few years, to the extent, at least, that railroads all over the country are very rapidly recognizing the fact that a big leak in their expenditures is through the manner in which their car departments have been handled in the past. I have found that more money can be saved or thrown away (and no one any the wiser for it) in the car department than any other department on the road.

Mr. Brazier, in his remarks, has said that this association is one of the most important in the country. By getting together and going over the Rules of Interchange thoroughly, you come to an understanding between yourselves in the interpretation of the

rules. This means, that instead of holding up cars all over the United States on account of differences of opinion among different inspectors, the rules are understood alike and the cars are kept moving, and particularly at this time your understanding of the rules pays many, many times over the cost of sending you to this convention. I firmly believe that every railroad in the United States, Canada or Mexico cannot do better than to send a sufficient number of representatives to each one of your conventions and pay their



W. R. McMunn, Secy.-Treas.,  
Chief Interchange Car Inspectors'  
and Car Foremen's Association

expenses for the good that the roads themselves will derive from it.

#### ADDRESS OF MR. WRIGHT

There is one thing that those of us who are on the outside have come to appreciate greatly in recent years and that is the tremendous possibilities in the car department. The mechanical department has been very largely dominated by men who have come up through the locomotive department. Car department men have not always gotten their just deserts. Railway executives and those who are spending the money have come to realize that the car department is spending a tremendous amount and that it is vitally important to have big men—men of executive ability and men of business ability—to administer the work of that department. Car department men, realizing their responsibilities, are coming to assert themselves.

One great trouble with both our industrial concerns and our railroads has been that too little attention has been given to getting the right kind of young men into the ranks in order to carry on the work in the future. Last week there was a paper read before the Railway Club of Pittsburgh by George M. Basford, a great friend and source of inspiration to young men, in which he called attention to the big problems affecting the locomotive and its operation which must be solved; his idea was that here was a great opportunity for young men. As I listened to him the thought came to me that there were just as big problems to be solved in our car departments, possibly bigger ones, more efficient interchange methods, better maintenance to get full service value out of the cars, improved repair and inspection methods, better design, better practices in selecting and training men in order to increase the efficiency of the human element, and the building up of a wide-awake, enthusiastic organization are a few of the problems you are up against. Competition with industries has made your labor situation a most serious one. It requires real men to overcome these conditions. It is your opportunity.

There is another thing that has occurred to me as I have listened to your discussions, and that is the criticism of the mechanical engineers because they have designed cars and equipment which do not give the best results, that they have overlooked the practical difficulties that the car department men are up against. I wonder if we are right in charging that entirely to the mechanical engineer. If the car department men do not make a big enough noise to impress the mechanical engineer and those in charge of the designing of equipment, isn't it the fault of the car department? You have simply got to go after them until you can get them to see their mistakes and make them come to your way of thinking. I submit that you fellows who are right on the firing line ought to go to the mechanical engineer and keep after him until you get things right. There are greater possibilities in improving the design of our cars than we ever thought of in improving the design of the locomotive.

The solution of the car department problems and your future success is going to depend almost entirely upon what you do in selecting and training men to carry on the work of the car department. Too little attention has been given to that feature. The *Railway Mechanical Engineer* had a competition a year ago for the best articles on the qualifications and training of the car inspector. This competition brought out this truth—that too many roads were selecting their car inspectors almost as they can grab them at random. I honestly believe that unless we give the attention that we should to this matter of selecting the young men and training them specially for the car department that we will find ourselves in a serious predicament in the years to come.

#### DISCUSSION OF INTERCHANGE RULES

The discussion of the rules was confined largely to those which have been changed within the past year.

#### RULE 2, SECTION (b)

Cars loaded with explosives must be handled in accordance with the regulations of the Interstate Commerce Commission. Cars containing inflammable liquid which is leaking must be repaired or transferred without any unnecessary movement or at nearest available point.

T. J. O'Donnell (Buffalo): I would like to ask the interchange inspectors if, when they find a tank car leaking in the receiving yard where the inspection is made, they always insist upon the nearest repair point disposing of the load. Would gasoline be considered the same as fuel oil, or anything that is slow combustion?

G. Lynch (Cleveland): Where a car is leaking gasoline or any highly inflammable materials, it would be returned to the delivering line. If it is ordinary materials that are leaking we send it on to the receiving company's shop, or agent, for the necessary attention.

Mr. O'Donnell: My point was: Should the nearest repair point be the place to which the car is to be taken for repairs? The rules say "the nearest repair track."

Mr. Lynch: When a car is leaking, whether tank or box car, we have to dispose of it in accordance with local conditions. We try to save the return movement of the car as much as possible.

F. C. Schultz (Chicago): I fail to find a rule by which you can compel the receiving line to accept cars containing inflammable materials if delivered in a leaky condition. We ask the receiving line to carry out the intent of the M. C. B. rules.

Mr. O'Donnell: We force the receiving line to take leaking tank cars provided they have the nearest repair point, and the executive committee has upheld us, saying that it is a rule of the M. C. B. Association and that the car must be handled at the nearest point.

J. C. Keene (Wabash): At St. Louis we have a local arrangement whereby the cars must be inspected before delivery, but if found on the interchange track leaking, it is up to the receiving line to take steps to transfer the car, if necessary, and any extra expense is charged to the delivering line.

H. Boutet (Cincinnati): The rule says "the nearest available point." We try to transfer or repair the car with the least possible handling.

F. H. Hanson (N. Y. C. West): It is my understanding of the rule, that if cars are found in a defective condition and the delivering line's repair track is half a mile from the interchange point, and the receiving line's repair track is three miles away, according to these rules, the delivering line should repair the car because it would only be necessary to handle it a half mile as against three miles. It is always customary to have all cars go forward, but in accordance with this rule, we should give the car the necessary attention at the nearest available repair point. I move, therefore, that it is the understanding of this meeting that that portion of Rule 2 means that the car must be repaired at the nearest available repair point, regardless of whether it is the receiving or delivering line's.

Mr. Lynch: I agree with Mr. Schultz that you cannot compel the receiving line to take a leaking tank car with gasoline or anything of that kind unless it be released from loss and damage. We have had some China oil shipped in box cars. It is very penetrating and sometimes the barrels leak very badly. In one case when the cars were offered to a connecting line they were taken and the loss and work done to the barrels to put them in forwarding condition was reported to the delivering line which refused to release the receiving line from responsibility for this loss and damage. The delivering line took the stand before the committee and was beaten. The committee upheld the receiving line in its stand that it was not obliged to take the cars unless the delivering line gave it a release.

Mr. O'Donnell: We are supposed to uphold these rules. I would not have any hesitancy in telling the delivering line

"It is your load," and let the officials fight it out afterward. The foundation of our agreement is to expedite the movement of cars.

M. H. Halbert (St. Louis): Mr. O'Donnell has expressed my views. In the St. Louis territory we have such cars repaired by the receiving line in a good many cases. Whenever we can, we keep the commodity moving in the direction it is billed.

N. B. Elliott (St. L. & S. F.): You will find that 50 per cent of the tank cars you transfer are not leaking at all. They are just seeping.

Mr. Hanson's motion was then put to a vote and carried.

#### RULE 2, SECTION (f), PAR. 3

All other truck defects on foreign cars, except metal bolsters, center plates where cast integral with bolsters, metal truck sides, metal truck transoms and metal spring planks; also excepting non-M. C. B. standard journal boxes and contained parts in cases where the M. C. B. standard is not a proper substitute.

W. M. House (So. Ry.): The rule says all other truck defects on foreign cars. What do we term a defect? Is a solid pedestal truck that is cracked one inch or 1½ in. considered a defect? Or are we going to be permitted to run the car and load, with safety. Or are we to get a transfer order for such cars?

President Kipp: The chair decides that the receiving line would be the judge as to whether it would be a defect that was safe to run.

Mr. House: The chief joint inspector will say that the car is safe to run. The truck frame is not broken; it is cracked. We know that a crack in a solid pedestal truck is not going to get better.

Mr. O'Donnell: Where the crack runs into the web it is dangerous. Where it is only in a half inch, if the load is in first class condition, we take a chance on it, but the receiving line is the judge. It is up to the delivering line to give protection.

#### RULE 2, SECTION (f), PAR. 6

Renewal of roof boards of outside wooden roofs, and of inside metal roofs, where such renewal does not exceed 25 per cent of the roof boards, and where purlines, rafters, ridge pole, side and end plates are in good condition, on all cars.

A. Armstrong (Atlanta): What reference is there in the rule to the condition of the metal roof? If there are ten sheets of inside metal roof missing, which would be within the 25 per cent, and not covered by the 25 per cent of the outside roof, does it mean that you can renew one or both?

J. J. Gainey (C. N. O. & T. P.): The rule is plain. It says if there is any part of the inside roof gone you are entitled to a transfer. It does not refer to the metal roof at all. It refers to the double board roof, or roof boards over a metal roof. It does not pertain to the metal roof.

H. Boutet (Cincinnati): I move that the interpretation of the rule be as given by Mr. Gainey. (The motion was carried).

#### RULE 2, SECTION (j)

When load is not transferred, the car, if foreign, may be returned, when empty, to the delivering line, properly side-carded on both sides of car with a bad order return when empty card, showing the defects for which the car is returned, in which case it must be accepted. For card see page 229.

F. C. Schultz (Chicago): Some people are under the impression that they can run a car all over the line, reload it and then return it after applying "bad order" cards.

Voice: You interpret it as a switch car on that company's line?

Mr. Schultz: Exactly.

G. Lynch (Cleveland): I interpret it the same as Mr. Schultz. There is a question and answer at the bottom of page 5 in the Rules which explains it clearly.

Mr. Schultz: Under a local agreement if a car is away 60 days and requires such repairs, we require the delivering line to make them.

Mr. Lynch: There is no limit to that as far as Cleveland is concerned.

S. Skidmore (C. C. C. & St. L.): The Arbitration Committee has disposed of that question by an interpretation as follows: "Your committee feels that such a foreign car moving on its home route empty must be accepted, if in the same physical condition that it was when forwarded under load."

Mr. Schultz: We should take some steps at this time to interpret the rules uniformly. The large interchange points should get together, have the interchange committee work out a rule that will be universally endorsed.

H. Boutet (Cincinnati): As far as Cincinnati is concerned, we work exactly as Mr. Lynch does. If a car comes back in the same condition in which it was delivered, it is accepted.

Mr. Schultz: I do not believe that at large terminals a car which is empty, moving in its right direction, should be set back for any condition, for the reason that if it is set back it has to move back through the same channel.

M. H. Halbert (St. Louis): We have no rules in St. Louis under which the delivering line is held responsible for the condition of, and the returning of, an empty car, providing the defects under Rule 120 do not exist. If a car is safe to handle the load, we will accept it on its return or empty movement, even though it has defects other than those with which it was received. Any car that originates on the line, we handle just the same as if it were a foreign car; when it is returned to the delivering line or the originating line, it will take care of all car owner defects and delivering line defects, as far as cardable defects are concerned. When the defects come under Rule 120, we hold the delivering line responsible for the disposition of the car. However, we will card all cardable defects to the originating line. The originating line must take care of all car owner defects. If one line delivers a car to another line with defects that should be repaired before it is safe to take to its destination, on the return of that car even though it is in a worse condition, we have the delivering line take care of the repairs.

J. J. Gainey (C. N. O. & T. P.): Recommendation along the line of the argument of Mr. Schultz and Mr. Halbert was put to the Arbitration Committee and it disapproved it.

Mr. Halbert: I do not think they looked into it far enough. We have the biggest interchange point in the United States and if the committee will stop and consider the way we get traffic through the gateway of St. Louis, it will come to it. Take care of the other fellow's car when it originates on your line and help it through.

Mr. Gainey: The arbitration committee says "Not approved. The object of the present rule is to obtain better maintenance of foreign cars away from home, and it is believed that the proposed change would have no other effect than to defeat this object."

President Kipp: In view of the decision of the Arbitration Committee, St. Louis seems to be operating contrary to the spirit of the rules and should take such measures as may be necessary to have the practice changed.

#### RULE 3, SECTION (c)

Cars built after October 1, 1914, and prior to January 1, 1917, will not be accepted in interchange unless equipped with either the No. 1 or the No. 2 M. C. B. standard brake beam, as indicated by the light weight of the car. Cars built after January 1, 1917, must be equipped with metal brake beams of not less than the capacity of the No. 2 M. C. B. standard, or stronger, as the conditions may require. All of the brake beams referred to shall have the letters "M. C. B." and proper number plainly stamped or cast on strut, as required by the specifications. After October 1, 1918, cars will not be accepted in interchange unless equipped with all-metal brake beams.

E. Pendleton (Peoria): Tell us what a No. 1 and No. 2 brake beam should be applied to.

W. R. McMunn (N. Y. C.): A car weighing over 35,000 lb. should have a No. 2 beam; under 35,000 lb. it may have a No. 1 beam.



F. H. Hanson (N. Y. C. West): How is an inspector going to tell whether a beam is stamped No. 1 or No. 2?

President Kipp: A man cannot find out without the liability of getting his head cut off.

H. H. Harvey (C. B. & Q.) I think that Mr. Hanson is entirely right and that it is up to this association to make a recommendation to the M. C. B. Committee on Standards, or the Brake Beam Committee, or the Arbitration Committee, that brake beams must be marked on the brake head and not on the brake strut.

Mr. O'Donnell: It has been brought to the attention of the M. C. B. Association and it appreciates the fact and is, I understand, going to correct it.

Mr. Pendleton: There is another thing that should be called to its attention and that is the stenciling of cars equipped with metal brake beams. Cars should be marked showing type or number of the beam standard.

#### RULE 3, SECTION (e)

Tank cars (empty or loaded) will not be accepted in interchange unless they comply with the M. C. B. Tank Car Specifications.

Note.—It will be understood that all tank cars carrying safety valves must have the valves tested and the tanks tested and stenciled, as required by the specifications, regardless of the commodity carried in the car. Tanks only shall be stenciled to show tests of valves and tanks.

Mr. Skidmore: There has been some discussion here about the stamping of safety valves on tank cars and whether or not it is still a requirement of the rules. My understanding is that a valve requires stamping just the same as heretofore. If the stenciling on the tank is obliterated we still have the stamp on valve to go by.

Mr. Gainey: The present specifications require that the record of test of safety valve shall be stamped on the body of the valve in addition to being stamped on the tank.

F. W. Trapnell (Kansas City): The M. C. B. Association knows something of the difficulties under which the inspectors labor, when tanks are loaded, to get the desired information from the safety valve and they have made a provision in the rules whereby, if the tank is properly stenciled, the inspector does not have to bother to inspect the valve, and I move that that interpretation is the sense of this body.

The motion was carried.

#### RULE 4, PAR. 2

Defect cards shall not be required for any damage that is so slight that no repairs are necessary.

J. C. Keene (Wabash): The lack of a uniform interpretation of this paragraph is one of the most serious problems we have to deal with today, and one that is causing a great deal of unnecessary correspondence and trouble. This rule specifies that defect cards shall not be required for defects so slight that no repairs are necessary, but renders no interpretation of what is to be or shall be considered necessary repairs. I would say repairs should be made at the time of interchange or no defect cards be issued. Certainly if a car with a raked siding or roofing is safe to carry its load to its destination without damage to the contents of the car no repairs would be necessary. Bent parts on metal cars not requiring immediate shopping rarely weaken the construction and are seldom repaired until the cars are placed in the shops for rebuilding or reinforcing. This is proved by the fact that defect cards in a great many cases are not used for two or even three years after date of issuance, a practice which in my opinion is wrong.

The Master Car Builders' arbitration committee has ruled that where defects are passed as not necessary to card, and later carded at another interchange point, no rebuttal cards should be issued. Consequently to avoid further complaint and criticism the inspector tightens up on his carding, issuing defect cards to please the fellow at the other end of the line and not in accordance with his own judgment. In order to overcome this condition and reduce the carding to what it

should be, some points have adopted local agreements to protect the inspector furnishing defect card on the record if carded at another point, but I feel the difficulty would best be remedied by a universal understanding or interpretation of this rule.

F. W. Trapnell (Kansas City): Defect cards should be applied under the supervision of a chief interchange inspector, who would see that the rules are properly complied with and that no card is issued unless the car owner is justly entitled to it and stop the present practice of the great abuse of the defect card. The second paragraph of the rule should be changed to read "No defect card to be issued by inspector in connection for any damage which does not require immediate repairs." In the third paragraph the rules state that "At outlying points where joint inspection is not in effect the matter be left to the judgment of the receiving line." This is costing the railroads large sums of money, as the inspectors demand defect cards for damage so slight that it is scarcely visible, and without the proper supervision this practice will still be continued. I have taken defect cards off cars where the siding has been marked by a nail or some one holding a piece of wood against the side of car when moving and which had not raked through the paint, and in some instances the inspector has carded for one-half of the siding on one side of the car. Others demand defect cards for owner's defects such as end sheathing broken out (new defect), old air date, draft timber bolts and lug bolt broken (old defect), paint scorched on five side planks A & B ends, pitch only drawn out by sun, and other cards for damage too slight to mention. If the owner gets the card it can bill the line whose defect card is on the car for the total amount covered by the defect card, as per Arbitration Cases Nos. 319, 397 and 399, which rule that the ignorance of the one applying the defect card is no excuse, and it must carry with it the admission of the delivering line's liability.

The judgment of the inspectors are at variance, some using good judgment; others, equally as good inspectors, are not allowed to use any judgment, but card for everything possible according to instructions. Some of these cards remain on cars four and five years and as no repairs were necessary at the time the card was issued no bill should be made.

Again cars are passed by an inspector at one interchange point and carded by another inspector at the next point, resulting in the first inspector being severely criticized for not applying a defect card for defects which in his opinion required no repairs. Consequently he tightens up on his interchange inspection and gives his company the benefit of any doubt, which results in the application of defect cards for technicalities, setting a bad example for other inspectors.

F. C. Schultz (Chicago): A cardable defect ought to be a defect which required repairs before the car could be handled, and this should apply to foreign as well as to home cars. I am well satisfied in my own mind that at least 75 per cent of the defects on cars that are being carded are defects which could safely be allowed to exist, and are allowed to exist, until at some future time the car is placed in the shop for an entirely different reason. The present system is wrong.

T. J. O'Donnell (Buffalo): Many officials issue instructions to their foremen to get down closer on the carding. The result is that the stubs begin to come in to our department 50 per cent heavier. I took it up with some of our officials who issued such cards and they said: "We are willing to waive these instructions if you can get the other points to let up." Why should such orders be issued promiscuously in the yards? It would be better to have a conference and ask those issuing such instructions if they feel that they are observing the M. C. B. Rules, or whether they are allowing cars to get away from the district that should be protected. You can easily get a medium of decency. I think the inspectors are using their very best judgment under the conditions.

G. Lynch (Cleveland): Some of the car inspectors are

directly under the supervision of the chief joint inspector and others under the supervision of the local foremen of the receiving lines; if the latter, you can never get uniformity. Where you have as many different foremen as you have at the local points, you will have just as many different instructions. Your inspectors will never use their own judgment but will want to protect themselves and thus issue defect cards indiscriminately.

H. J. Smith (D. L. & W.): The solution for a great part of the difficulty would be to place a time limit for billing on defect cards.

Mr. Schultz: Only about 40 per cent of the defect cards are billed on. That is the best evidence, at least, that many are issued for defects that should not be carded. A proper interpretation of this rule is the solution of the whole situation. You cannot go before anybody and stop them issuing defect cards. The suggestion made by Mr. Keene is none too broad: We would make this read: "Defect cards should not be required for any damage that is so slight that immediate repairs are not necessary."

W. K. Carr (N. & W.): There are cars that go around two or three years with defect cards on. Ten or fifteen years ago we had a six months' limit on a defect card. Why not put that limit on today and if repairs are not made within that time, it is lost.

H. H. Harvey (C. B. & Q.): I had occasion to check up the defect cards that were issued against our road for a period of six months. I found 51 per cent of the cards that were issued, either by the Burlington or by other roads against the Burlington, had not been billed on. That is pretty good evidence, to my mind, that there is not so much dishonesty in billing on defect cards as some would lead us to believe. I agree with everything that has been said about issuing defect cards. And I hope the time will come when there is no such thing as a defect card. It may be a raked side sheathing but it is a delivering line defect and the inspector wants a card and I do not see how you are going to get away from permitting him to have a card under the present M. C. B. Rules.

S. Skidmore (C. C. C. & St. L.): There are a number of lines receiving loaded cars with defects which do not require immediate repairs because of the fact that the cars are loaded and can be allowed to go to their destination. The car comes back to the owner and the inspector concludes that the car requires immediate attention because they can get a defect card against the delivering line. It is marked "repair track" and they get a defect card. According to the argument here that would be just and equitable. They pass these cars through from the West, or the East, loaded. They are good enough to pass them along, and when they come back empty the car inspector jumps on them and gives a defect card against the delivering line for the defect. Why? Because they can get a defect card where it requires immediate repairs and you cannot dispute them on it. Why should not the car be carded when it leaves the line.

Mr. Trapnell: I move you that the chair appoint a committee to bring in a report on a proper interpretation of the second paragraph of Rule 4. Mr. Trapnell's motion was seconded.

Mr. Lynch: In line with Mr. Skidmore's remarks, I find it necessary in cases of cars loaded with perishable freight where they have been badly wrecked or cornered to make temporary repairs and cover the damaged part with rough boards. It is necessary to card such cars that can be repaired when empty.

Mr. O'Donnell: I really think the trouble is not the fault of the supervision. It is the feeling of fear that cars passing between roads will be carded against them. The inspector should know when to put a card on a car. You can look at it and in an instant you can say: "If I had to pay for these repairs out of my pocket, I would not pay it." Why

not say the same thing for the delivering line. We are working for the railroads; let's be decent with them.

M. H. Halbert (St. Louis): We handle interchange perhaps a little differently from any interchange point in the country. The receiving inspector does not issue M. C. B. defect cards for defects on empty cars that do not require repairs. Should the car be defect carded it is sent to the repair track to be handled with the foreman of the receiving line. If he cuts out a loaded car or puts a card on a car for cardable defects, the original stub is turned into my office and I make it my business, when I find a stub that does not look right, to make an investigation. There is no foreman in our territory who can tell me what to card and what not to card. He is under my jurisdiction and if he cards right I will back him up, but if he cards wrong, I do not.

Mr. Trapnell's motion was put and carried.

The report of the committee follows:

"Your committee appointed to take up and report specially on the second clause of Rule 4, in so far as the use of defect cards are concerned for damages too slight to warrant repairs, respectfully submits the following:

"*First:* This rule was incorporated by the Master Car Builders' Association to overcome the abuse of defect cards in interchange and has been in the rules for a number of years and your committee at the outset feels that we should respect and live up to and follow the strict intent of this rule.

"*Second:* The rule provides that the chief joint interchange inspector is the judge for carrying out the intent of this rule and it is felt by your committee that in many cases it is merely nominal and not positive and if arrangements could be made that the intent and purpose of this rule could be absolutely covered by the chief joint interchange inspector and any local changes desired by roads bearing on the same, must be handled through the chief joint interchange inspector and his decision be final in all cases.

"*Third:* In submitting this recommendation, it is given with the full intent and understanding that all members of this association will use their personal and best efforts to correct this evil, as we feel it can only be corrected by the hearty co-operation of the different interchange points, which is submitted with the understanding that it is acceptable."

The report was signed by: T. J. O'Donnell (Buffalo), F. C. Schultz (Chicago), S. Skidmore (C. C. C. & St. L.), H. H. Harvey (C. B. & Q.), W. M. House (So. Ry.), F. W. Trapnell (Kansas City), J. J. Gainey (C. N. O. & T. P.), J. P. Carney (M. C.), and H. J. Smith (D. L. & W.).

#### RULE 4, PAR. 4

Defect cards shall not be required for missing material in fair usage from cars offered in interchange. Neither shall they be required of the delivering company for improper repairs that were not made by it, with the exception of the cases provided for in Rules 56, 57 and 70.

W. K. Carr (N. & W.): There seems to be a difference of opinion in regard to defect cards. The difference is on the question of what constitutes fair usage. For instance, take a gondola that has 50-in. steel sides with four  $5\frac{3}{8}$ -in. by  $2\frac{1}{2}$ -in. cross pieces at the top, which comes down on the outside and is secured with an inch rivet. When that brace is missing it is considered fair usage at some points and at others it is unfair usage. Which is correct?

President Kipp: The Arbitration Committee has decided that angle bars and cross tie rods are at owner's risk and I assume that this is along that line.

Mr. Carr: That is a concealed part.

President Kipp: It may be observed by an exterior inspection.

Mr. Carr: You can see the brace under all conditions and it cannot be removed under fair usage.

W. J. Babcock (D. & H.): The company for which I work has the same trouble and I have the decision to which Mr. Kipp refers. The decision as I see it, refers to tem-

porary transverse tie rod and not permanent transverse tie rods and angles with which the cars are originally built and designed. These cross tie angle rods are visible from the outside. The rod goes through the car and there are nuts on the outside of each side of the car. It is a well known fact that 90 per cent of these cross tie angle bars are removed by shippers to facilitate the loading and unloading of cars, with clam-shells, etc., and I cannot see where that is an owner's defect when they are removed by the shipper. It is not fair usage to remove these and leave them out and compel the owner to put them back again. It would appear that it is the duty of the delivering line to compel the shipper to put them back.

Mr. Carr: Those rods and these cross rods I refer to are not comparable. The braces we put on are riveted. They are permanent fixtures and if you remove them you have destroyed the construction of the car.

J. H. Weal (N. Y. C.): I think Rule 21 paragraph B clears the thing up.

C. R. Dobson (C. R. I. & P.): I think Rule 43 covers that.

F. H. Hanson (N. Y. C.): I believe that the car was constructed wrong. A man has a perfect right to cut these rods out in order to load lumber. I believe that a car in that condition should be an owner's defect.

Mr. O'Donnell: When you build a car it is supposed to have the approval of the American Railway Association, unless you stencil the car to show that it should not be loaded with such commodities.

Mr. Carr: The car is strictly a coal car.

RULE 9

W. J. Babcock (D. & H.): If you apply a Westinghouse triple made by the New York Air Brake Company and stamped "New York," what would you show as the type?

Answer: We would show Westinghouse triple valve.

F. H. Hanson (N. Y. C., West): Is it necessary to sign joint evidence card for an H-1 New York triple when applied in place of a K-2 Westinghouse? There is a difference in the price.

President Kipp: The chair would say that it would not be permissible to apply an H-1 valve in place of a K-2; in other words, it would be wrong repairs.

Mr. Babcock: I take it these two triples do not perform the same function. One has a retarding device and the other has not. They are not of similar type. You can exchange a New York triple in place of a Westinghouse if it is the same type—if it performs identically the same function; otherwise you make wrong repairs. The prices of the two triple valves of similar type are the same.

RULE 33

Owners will not be responsible for the expense of repairing or replacing ladders, handholds, sill steps or brake shafts, whether or not in connection with other repairs.

F. H. Hanson (N. Y. C., West): If we get a car equipped with U. S. safety appliances and it is equipped with a hand hold which does not meet the requirements, can you change this and bill the car owner for the expense? A great many roads are doing it.

N. B. Elliott (St. L. & S. F.): We have been doing that right along, and render bill.

Question: How about cars not equipped with the U. S. safety appliances?

Mr. Hanson: That is an owner's expense. We write the owner and there are no questions asked whatever if we equip the car with safety appliances. But the part I refer to is, are we justified by a strict application of Rule 33 in billing the car owner for the change of any of these parts? Our billing department has advised me that there has not been a single case where the owners would not accept bill.

President Kipp: The rule is very plain. The chair would

decide that you cannot bill the owner of the car for any of these items without authority to do so.

W. R. McMunn (N. Y. C.): As I understand this proposition, all cars built on and after July 1, 1911, must have been equipped with the U. S. safety appliances standards. Any car built prior to July 1, 1911, must after a certain date be equipped with U. S. safety appliances. At the present time it is a violation of the law to accept a car built after July 1, 1911, unless it meets the requirements of the U. S. safety appliance law in every detail. Cars built prior to July 1, 1911, may be equipped with U. S. safety appliances. When you once accept a car you assume responsibility for it and any repairs that may be necessary to safety appliances, must be assumed by the handling line.

E. Pendleton (Peoria): It seems to me that under the interpretations given on page 63 it is a handling company's defect, and I would move that that be the interpretation of this body.

The motion was carried.

RULE 36, SECTION 3

Special Placards.—These shall be such as are required by the "Interstate Commerce Commission Regulations for the Transportation of Explosives and other dangerous articles by freight and by express," and are to be of the size as therein described. They shall be used, be of the text and be attached to the cars as prescribed by said regulations.

A. Armstrong (Atlanta): If a car bearing these placards has been made empty and returned to your line, may you remove them and bill the delivering line the same as an advertisement?

Mr. Schultz: The American Railway Association recommended to the M. C. B. Association that this be made a penalty. I think the M. C. B. Association did not agree with it, and since it did not see fit to include it in the rules it is not a cardable defect.

RULE 43

Owners Responsible.—Any damage to all-steel or steel-underframe cars, unless such damage occurred in wreck, derailment, cornering or side-swiping, and except unconcealed fire damage.

G. Lynch (Cleveland): In view of the recent decision of the Arbitration Committee that drop doors on steel cars cannot be lost in fair usage and that, therefore, the delivering line is responsible, I want to ask the chief joint inspectors present if, when steel cars with doors, drop or hopper, are offered in interchange with one or more missing, is it a cardable defect? Does this decision make the delivering line responsible for missing doors of gondola cars?

President Kipp: I would say that the decision is final and binding. A door found missing under the conditions described by the Arbitration Committee decision would be a cardable defect in interchanges.

Mr. Lynch: In loading ore on the hoppers, the weight will carry the door away because of the mechanism of the door, or the parts securing the door. The loader permits the car to be loaded to capacity. We sometimes find the same thing in loading stone. It is not uncommon to find a door or two missing on these cars and the car is loaded. Are we going to make the delivering line responsible?

A. M. Patrick (Mechanicsville, N. Y.): Issue a defect card. It is a cardable defect.

H. Boutet (Cincinnati): I believe a majority of the interchange inspectors understand Rule 43 to mean that it is an owner's defect unless there was evidence of unfair usage.

Mr. Trapnell: The Arbitration Committee has laid down this emphatic rule for us to work by, and they have not told us we could use our judgment in the matter unless certain things have occurred to the car. If certain things have occurred, then we can card; otherwise we cannot.

Mr. Pendleton: Perhaps the Arbitration Committee had some information which guided it in the decision that we do not know anything about, but the fact remains, as we understand the rule, and as it has been interpreted to us by the

Arbitration Committee, that without evidence of unfair usage, the damage should be charged to the car owner and we should decline to card.

#### RULE 58

Delivering Company Responsible.—Air brake hose, when missing complete, missing cylinders, reservoirs, triple valves, interior parts of triple valves, angle cocks, cut-out cocks, dirt collectors, pressure-retaining valves, release valves, pipe or pipe fittings; also damage to any of these parts when such damage is due to wreck, derailment, cornering or sideswiping.

G. Lynch (Cleveland): Is an angle cock handle broken an owner's defect? As I understand it, if there is no evidence of unfair usage, the owner is responsible.

T. J. O'Donnell (Buffalo): The usual way of breaking the handle is by the trainmen hitting it with a hammer. It should be delivering line defect.

J. V. Berg (N. Y. C., West): A broken angle cock is owner's defect according to the rule.

F. H. Hanson (N. Y. C.): I move that it is the sense of this association that it is an owner's defect.

The motion was carried.

#### RULE 80

T. E. Giblin (C. & A.): The size of the journal is not quite clear. On the 80,000 lb. capacity cars it says— $4\frac{1}{2}$  in. journal;  $6\frac{1}{4}$  in. wheel seat and a  $5\frac{5}{16}$  in. axle center, which is  $1/16$  in. larger than the M. C. B. standard. The other measurements are M. C. B. standard. A non-M. C. B. axle of the 80,000 lb. capacity measures the same as M. C. B. with the exception of the axle center which is  $1/16$  in. larger than the M. C. B. standard.

Mr. Pendleton: While the axle center is  $1/16$  in. greater than the M. C. B. standard, it applies to the M. C. B. standard axle. I cannot understand it in any other way than if you maintain a non-M. C. B. axle, it must not be less than these measurements.

H. Cockran (B. & O.): An axle removed for any cause whatever must be less than the prescribed limits. Suppose it reaches those limits but does not go below; is it a scrap axle?

Voice: It says below the prescribed limits.

Mr. Hanson: I have never heard of an 80,000 lb. non-M. C. B. standard axle and believe the dimensions shown are in error, particularly as to wheel seat.

C. J. Hayes (N. Y. C.): I believe the measurements given on page 108 for 80,000 lb. and 100,000 lb. capacity axles are  $1/8$  in. less than the M. C. B. dimensions. It came out in a circular under the 1915 rules that there should be a variation allowed for rough turning; on the 100,000 lb. and 80,000 lb. capacity cars  $1/8$  in. should be allowed, and on the 60,000 lb.,  $1/16$  in. should be allowed. These dimensions have been reduced to conform to the allowances the committee gave.

Voice: They do not make any allowance on the non-M. C. B. standard.

Answer: They ruled that sufficient allowance was made on the non-M. C. B. axle.

#### RULE 98

S. Hansen (P. & P. U.): Is there any overlapping labor charge in changing two pair of wheels in the same truck?

F. C. Schultz (Chicago): It seems reasonable if you remove two pair of wheels on the same truck there should be some credit as it reduces the amount of work considerably for the second pair. The foot note seems to be an explanation.

C. J. Hayes (N. Y. C.): A reduction of 28 cents ought to be made when two pair of wheels are removed from each truck. If you had a pair of wheels on A end and a pair on B end of the car, no reduction would be made.

#### RULE 99, PAR. 2

When axle is removed on account of owner's defects on wheel, and the journal has increased in length more than  $3/8$  in. or the collar is worn to

less than  $5/16$  in., or the diameter of the journal is not at least  $1/8$  in. greater than the limiting diameters given in Rule 86, the axle shall be considered as scrap and credit allowed accordingly.

C. J. Hayes (N. Y. C.): Referring to the second paragraph, I move that it is the understanding of this association that when the axle removed does not come up to the requirements in regard to dimensions; it should be scrapped against the owner.

The motion was carried.

#### RULE 102, PAR. 3

In computing charges for bolts, nuts and forgings, if fractional weight of each entry on billing repair card is less than one-half pound, it must be dropped; if one-half pound or more, charge the entire pound.

W. J. Babcock (D. & H.): If the weight of the bolts or nuts applied is less than  $1/2$  lb. you would drop it. If in making heavy repairs and the number of different sized nuts were under a half a pound, would you take the aggregate weight and in that way secure what you are entitled to?

J. C. Keene (Wabash): If less than a half a pound, you should forget it, but you are permitted labor in all cases.

Mr. Hayes: You cannot take the nuts or small bolts in the aggregate. We have to make the extensions under each item and if less than  $1/2$  lb., you would then drop it.

Mr. Schultz: That does not seem right. You are liable to lose two or three pounds on one job. You can only drop the fraction of the pound in closing up your total weights.

Voice: It says each entry. It does not say the aggregate.

F. W. Trapnell (Kansas City): I move that this be sent to the Arbitration Committee for interpretation.

Mr. Babcock: Before this rule was put into effect, the road which I represent had an agreement with several of our connections to try it out. We took several large bills against us that amounted to \$400 or \$500 from four different roads. We figured out all the nut charges on the actual basis of the overcharges and the undercharges and in no case did it amount to over \$2.00 in a \$600 bill, either one way or the other.

The motion to refer the rule to the Arbitration Committee was carried.

### PASSENGER CAR RULES

F. W. TRAPNELL (Kansas City): The preface of these rules makes damage occurring in ordinary service, etc., car owner's responsibility. During the movement of troops, and, also, with a great number of tourist cars in interchange, we find many cars running with broken window glass and broken vestibule door glass. There is no indication on the car that it has received unfair usage. Would that be owner's or delivery line's responsibility?

W. R. McMunn (N. Y. C.): It will be admitted that the intent of the rule at the present time is that damage to any part of a car which can be seen without entering it; is considered delivering line responsibility, but that any defect which cannot be seen without entering car would be considered owner's responsibility. The inside parts would be considered owner's responsibility. My judgment is that broken window glass would be delivering company's responsibility.

### APPRENTICESHIP COMPETITION

The following awards were made in the competition for the best article on car department apprenticeship: First prize of \$25 to B. F. Patram, foreman car repairs, Southern Railway, South Richmond, Va.; second prize, C. N. Swanson, superintendent of car shops, Atchison, Topeka & Santa Fe, Topeka, Kan.; third prize, W. K. Carr, chief car inspector, Norfolk & Western, Roanoke, Va. The first prize article follows, and the others, as well as abstracts from the best of the other papers which were presented in the competition, will be published in future issues.

## CAR DEPARTMENT APPRENTICES

(FIRST PRIZE)

BY B. F. PATRAM  
Southern Railway

The question of apprenticeship in either car building or car repairing today is one that requires a great deal more thought, study and consideration than it has ever received since its inception. With the proper training along mechanical lines very much better mechanics for the passenger department can be made out of bright, energetic boys than by any other method known to me. However, there are a great many things other than strictly mechanical ideas that should be instilled into the boy's mind during the first and second years of his apprenticeship. The main points that should be carefully considered are to train the boy to be watchful, alert, quick to respond and neat. The first impression made on the apprentice's mind is very important, for his mind is young and receptive and when the boy is made to see and understand he does not soon forget.

An apprentice in the passenger car department should have at least passed through the sixth grammar grade, or its equivalent in schooling, and his fitness or degree of education should be determined by an examination prepared by the head of the car department. After passing this examination, and it has been decided that the boy will start on his apprenticeship, he should be put to work, and should carry out the following schedule:

- Six months building and repairing passenger car trucks;
- Six months building and repairing platforms;
- Six months in the mill, laying off work only;
- Six months building and repairing engine cabs and pilots;
- Twelve months working on the outside of passenger car bodies;
- Twelve months working on the inside of passenger car bodies.

If this schedule is thoroughly carried out it should qualify the boy for any position in the car department. If, at the end of the first six months, the boy does not show the proper aptitude to make an efficient car builder and repairer he should be transferred to some other branch of the railroad business to which it is thought he is better suited. During the four years' course the importance of a technical education should be impressed upon the mind of the apprentice and everything possible should be done by those in authority to assist the apprentice in securing it. He should be offered every assistance possible in securing a thorough knowledge of the M. C. B. Rules, especially along the lines of interchange work and building and repair work.

As to the building and repairing of freight equipment cars, I am strongly of the opinion that an apprenticeship system in this department of the car business is not only unnecessary but offers no advantage either to the railroad or to the men employed in this branch of the service. However, I would advocate the use of helpers, who should be advanced as they qualify themselves to do this class of work. My reason for not advocating an apprenticeship course in the freight car department is as follows: First, there is no incentive for the young man to serve as an apprentice to a freight car builder or repairer because it would be necessary, owing to present conditions, for the boy to work side by side with men who were advanced from freight car helpers to freight car builders and repairers, in a much shorter time than is required in the apprenticeship course. Second, the pay of the freight car builders and repairers being so much out of proportion to the pay in other mechanical lines of railroad work, the railroad companies and the employing heads would have difficulty in securing the services of young men meeting the qualifications which would be required of them.

### INDIVIDUAL PAPERS

The following papers were presented and will be published in future issues: Co-operation Between Yard and Repair Forces, by R. H. Dyer, Norfolk & Western; Passenger Car Work, by J. R. Schrader, New York Central; Car Depart-

ment Organization and Efficiency, by C. R. Dobson, Chicago, Rock Island & Pacific; committee report on M. C. B. Billing and Repair Cards, J. V. Berg, New York Central, chairman; Interchange Inspection, by W. H. Sagstetter, Kansas City Southern, and J. J. Gainey, Cincinnati, New Orleans & Texas Pacific; Freight Car Maintenance, by J. J. Justus, New York Central, and H. H. Harvey, Chicago, Burlington & Quincy; Proper Loading of Cars, by W. H. Bettcher, Cincinnati, Indianapolis & Western; Handling of Equipment Repairs, by F. C. Schultz, Chicago; Sand Blasting Steel Equipment, by S. E. Breese; Passenger Car Work at Terminals, by C. Charlton. The following paper was also presented:

### PASSENGER CAR CLEANING AND SANITATION

BY E. P. MARSH  
Chicago & North Western

On the North Western the shopping period for passenger cars averages 15 months and it has not been found necessary to make a general practice of giving the cars intermediate light repair and cleaning. Cars regularly assigned to two and three day runs are thoroughly cleaned each time they arrive at a terminal, while cars on one day runs are given a thorough cleaning every other day. This cleaning consists of the following operations:

*First*—Open all sash.

*Second*—Blow out car from the top down, giving special attention to the curtain boxes, the space over the top sash, cushions and underneath the heating pipes and seats. Blowing out the cars has been found to clean them just as well as, if not better than, the vacuum system and it is much more rapid.

*Third*—Brush off the upholstery and dust off the wood work.

*Fourth*—Wash the entire car, including the inside of the sash and floor.

*Fifth*—Wipe all wood work with a renovator, care being taken to leave no greasy surface.

While this is going on in the interior the outside is washed by means of a hose and long handled brushes, and if it is very dirty it is given an oxalic acid wash. The trucks, gas tanks and other exposed iron work along the sides of the car are brushed off with a solution of kerosene and water which gives them a clean, bright appearance.

The interior cleaning has been found to be best handled by gangs of three—two men and a woman. The men do the heavier and overhead work and the woman, the saloons and lighter work. On the outside three-men gangs, two men with brushes and one with the hose—have been found to be the best combination. The cleaning and steaming with live steam of all water coolers is done by special men assigned to this work only.

The regular inspection for defects in the running gear and the adjusting of brakes is made by regular gangs as soon as cars arrive in the yard. This work is done on a day-work basis, as is also the work of the carpenter, trimmer, plumber and lamp repairing forces. All of the car cleaning work, except that of cleaning the water coolers, is done on a piece work basis.

Considerable difficulty has been found in properly disinfecting the cars. While formaldehyde will kill the germ life it has been found wanting when used for exterminating such vermin as roaches; after some experimenting we have found that the burning of sulphur in the presence of water will do this work in a satisfactory manner. In all passenger carrying cars, not equipped with carpets, an 18 in. aisle strip of linoleum set into the floor, has been found to be cleaner, more sanitary and more economical than carpet or cocoa matting aisle strips.

As is the case in most all work, when good work is desired, it must be well paid for. The piece work system has enabled

us to obtain this result with an indifferent class of labor; by practice and diligence the amount of work done by each gang has increased and by vigilant inspection it has been held up in quality, so that good work is now being done in sufficient quantity to make the work remunerative enough to hold the men and so avoid the trouble due to constant changing in forces. The keynote of any efficient cleaning yard is an organization which runs almost of its own accord and only needs the touch of the car foreman's hand in smoothing out the emergency kinks.

#### OTHER BUSINESS

*Change in By-Laws.*—The by-laws of the association were modified in two instances. Article 3 was changed to read as follows:

"The membership shall be composed of car department officials, car foremen, chief interchange inspectors, chief car inspectors, chief clerks, chief M. C. B. billing clerks, also representatives of any private car line in the same capacity as active members and car inspectors, air brake inspectors and representatives of any railway supply firm as associate members."

Article 4 was changed to read as follows:

"The officers of this association shall consist of president, first vice-president, second vice-president, secretary-treasurer and past president and seven elective members, who shall constitute the executive committee, the junior past president acting as chairman."

*Secretary's Report.*—The secretary-treasurer reported a membership of 554 and a cash balance of \$379. There were 116 new members received during the convention. The secretary-treasurer was voted a bonus of \$25 in recognition of his arduous labors during the past year.

*New Officers.*—The following officers were elected for the ensuing year: President, W. J. Stoll, chief interchange inspector, Toledo, Ohio; first vice-president, J. J. Gainey, general car inspector, C. N. O. & T. P.; second vice-president, E. Pendleton, chief interchange inspector, Peoria, Ill.; secretary-treasurer, W. R. McMunn, general car inspector, New York Central, Albany, N. Y.

Resolutions were also adopted on the deaths of S. Hornby, J. W. Hogsett, J. F. Skala, and A. Faerber.

#### ENTERTAINMENT AND EXHIBITS

The committee in charge of entertainment features was as follows: L. S. Wright, the National Malleable Castings Co. (chairman) Chicago, Ill.; J. R. Mitchell, W. H. Miner Co. (secretary-treasurer) Chicago, Ill.; Charles Derby, Joyce-Cridland Co.; J. L. Stark, Chicago-Cleveland Car Roofing Co.; A. M. Wilson, Galena-Signal Oil Co.; Marshall de Angelis, American Steel Foundries; C. J. Wymer, Grip Nut Co.; C. J. W. Clawson, Bettendorf Co.; and C. F. McCuen, Standard Heating & Ventilating Co.

The following supply companies had exhibits or representatives at the convention:

American Rolling Mill Company, Middletown, O. Represented by Warren E. McCann.  
 American Brake Shoe & Foundry Company, Mahwah, N. J.  
 American Steel Foundries, Chicago. Represented by F. L. McCune, M. DeAngelis and W. G. Wallace.  
 Ball Chemical Company, Pittsburgh, Pa. Represented by J. A. Gohen.  
 Bettendorf Company, Bettendorf, Ia. Represented by C. J. Clawson and J. Brady.  
 Boss Nut Company, Chicago. Represented by W. G. Willcoxson and W. J. Fogg.  
 Canfield Bros. Company. Represented by A. J. Canfield.  
 Curtin Supply Company, Chicago. Represented by G. E. Fox.  
 Chicago Railway Equipment Company, Chicago. Represented by E. A. LaBarr.  
 Chicago-Cleveland Car Roof. Company, Chicago. Represented by F. H. Williams.  
 Camel Company, Chicago. Represented by J. F. Comee.  
 Ft. Pitt Malleable Iron Company, Pittsburgh, Pa. Represented by A. M. Fulton.  
 Gold Car Heating & Lighting Company, New York. Represented by E. A. Robbins.  
 Galena Signal Oil Company, Franklin, Pa. Represented by A. M. Wilson, F. B. Smith, W. E. Auger, G. A. Arn, D. J. Justice, J. A. Graham and R. E. Webb.

Grip Nut Company, New York. Represented by C. J. Wymer, Albert Roberts and W. E. Fowler.  
 Heath & Milligan Manufacturing Company, Chicago. Represented by W. H. Pratt.  
 Hewett Rubber Company, Buffalo, N. Y. Represented by W. J. King.  
 Hale & Kilburn Company, Philadelphia, Pa.  
 Imperial Railway Appliances Company. Represented by V. E. Sisson.  
 Joyce-Cridland Company, Dayton, Ohio. Represented by Chas. D. Derby.  
 W. H. Miner, Chicago.  
 Magnus Company, Chicago. Represented by Bruce Owens.  
 Mahr Manufacturing Company, Minneapolis, Minn. Represented by H. H. Warner and J. R. Mathews.  
 McConway & Torley Company, Pittsburgh, Pa.  
 A. O. Norton, Boston, Mass.  
 New York Air Brake Company, New York.  
 National Malleable Castings Company, Cleveland, O. Represented by L. S. Wright, J. V. Davison and George V. Martin.  
 Pressed Steel Manufacturing Company, Philadelphia, Pa.  
 Q & C Company, New York. Represented by Albert Robertson and G. C. Pool.  
 Standard Railway Equipment Company, New Kensington, Pa. Represented by W. A. Brewer and J. T. Crawley.  
 Southern Wheel Company, St. Louis, Mo. Represented by Allen Dunham.  
 Standard Heat & Ventilation Company, New York. Represented by U. F. McCune.  
 Standard Car Truck Company, Chicago.  
 Scullin Steel Company, St. Louis, Mo.  
 Templeton, Kenly & Co., Chicago. Represented by A. H. Beattys.  
 Universal Draft Gear Attachment Company, Chicago.  
 Union Draft Gear Company, Chicago. Represented by J. E. Tarelton and C. J. Gorman.  
 Westinghouse Air Brake Company, Pittsburgh, Pa. Represented by A. L. Berghue.  
 Western Railway Equipment Company, St. Louis, Mo. Represented by R. L. Landtin.

## THE ESSENTIAL REQUIREMENTS AND CORRECT TREATMENT OF HEAD-LININGS

BY H. M. BAXTER

The first, and most essential requirement of the ideal headlining material is absolute imperviousness to moisture, whether it be in the form of humidity in the atmosphere, rain, or as used for cleansing purposes. Needless to say, this is also the characteristic most difficult to obtain. Light weight is important; the material must not warp, and should not be affected by heat or cold, either moist or dry. Blistering or "spotting," splitting or separating are most serious faults, and no material with any tendency towards these defects should be considered as a headlining.

Metals will meet the majority of the above specifications, but there are two important draw-backs to the use of metal as headlining or other interior car finish. The first is its great heat conductivity, thus making the cars too susceptible to outside weather conditions and requiring too great an expenditure for heating. The second is that metal always looks, feels and sounds like metal. No paint or other finish can hide its identity.

There are numerous compositions on the market which take any finish very much the same as wood, are durable, practically non-conductors of heat and do not absorb moisture. In adopting a material of this nature, it is better, if other qualifications are even, to select one which is made in one solid homogeneous thickness, instead of being veneered or laminated, any form of lamination naturally supplying an opportunity for lodgement of moisture, which, being sealed up with paint or other finishing coats, is almost sure to cause blisters, splitting and warping.

Some of these compositions are not intended to be finished in any way and acids are used in their manufacture, which either repel or destroy paints, varnishes or marblizing and polishing compounds. They are largely manufactured for use in electrical insulation work, and it was through their use as switch-board panels that it was found possible to use similar material for the interior trim of passenger cars. They are also largely used for bushings and numerous other items which require special molded shapes. In the manufacture, the material can be curved and shaped so as to fit any angle in the car structure.

For any considerable order, body panels, etc., may be molded to exact size, it remaining only to fit them into place and do the necessary finishing. All of these materials will saw like thin wood, or rather veneer, but owing to the non-grain texture, it is necessary to use a very fine tooth saw.

For filling in the cracks between boards, covering nail heads, etc., each of the manufacturers usually markets a composition calking compound, which possesses the same characteristics as its parent board. It can be filled, sized and finished, so that the entire surface presents the appearance of one board.

As the composition and finish of each factory is slightly different it is obviously impossible to lay down a fixed rule for procedure in finishing. All of the materials, however, are made from a pulp of vegetable fibre; and one at least, is solely poplar wood pulp, the others ranging from an all wood pulp through mixtures of wood, cotton, hemp, etc.

Being entirely a vegetable product, therefore, it is safe to say that the usual first coat of paint must be a filler. While the surface unevenness will probably not be so pronounced as in natural wood, this filling coat will nevertheless have to be well rubbed in, with a good, heavy bristle brush, preferably flat, and as large as the surface will conveniently permit.

The only exception to the use of a filler as a first coat is when the material comes from the factory with a thorough coating of waterproof. In such cases a "filler" would not only be useless but would not "take," leaving the surface blotchy and uneven, which condition would surely leave its mark through all successive coats. The foundation must always be smooth and good to produce an attractive finish. For waterproofed surfaces, a good size should be evenly and smoothly applied. An ideal first coat size may be made by mixing  $\frac{3}{4}$  gal. commercial alcohol shellac and  $\frac{1}{4}$  gal. alcohol. This is inexpensive, is readily secured and will go much farther than any varnish size.

After the first coat has been decided upon, correctly applied and allowed to dry thoroughly, the finishing coats may be commenced. As they will necessarily vary widely, it is hardly possible to discuss them in any comprehensive way.

### FITTING UP CAR JOURNAL BRASSES\*

Care should be taken in renewing journal bearings to see that they have a proper crown bearing, that the lining is not loose, and that the journal is not marred or scratched in any way. The journal wedge should not be too tight on the bearing, for it will pinch the edges of the bearing to the journal. The edges will then act as a wiper and prevent the proper lubrication of the center of the bearing. Neither should the wedge be too loose, for too much crown bearing will have a tendency to break the bearing, there being too much concentration of the weight on the crown.

The average workman engaged in taking care of the packing of boxes has had all of these points brought to his attention on numerous occasions, and should and does understand the causes of journal heating, and the methods he should employ to avoid it. Yet every railroad experiences periodical epidemics of hot boxes. The attention of everyone is brought to the matter when this occurs, and for some time box packing receives more than its share of supervision. As soon as this is relaxed, the men again become careless, and another epidemic results. These epidemics are costly and could be eliminated to a large extent, barring such unusual conditions as floods, etc., if, instead of waiting until hot boxes become so numerous that they have to be called to the attention of the higher officials, each car foreman should periodically check up his methods of packing boxes and assure himself that the matter is being handled in accordance with instructions.

\*From a paper on Car Department Problems presented by E. E. Griest, master mechanic, Pennsylvania Lines, Ft. Wayne, Ind., at the General Foremen's Convention.

## CLASP BRAKES FOR HEAVY PASSENGER EQUIPMENT CARS\*

BY T. L. BURTON

Equipment Department, New York Central

The first requirements of a power brake are to stop the vehicle to which it is applied in the shortest possible distance, consistent with maximum rail adhesion, during emergency braking, and in the minimum distance, consistent with accuracy and smoothness, during service braking, all of which is largely dependent upon the type of equipment employed, the manner in which it may be operated and the braking ratio (percentage of brake power) that can be successfully used.

The braking requirements for present day heavy steel passenger car equipment can best be appreciated by a careful analysis of the records of a number of passenger train brake tests with the earlier light wooden cars and the heavy steel equipment of today, and for those who care to make such an analysis the paper which was presented by S. W. Dudley at the February, 1914, meeting of the American Society of Mechanical Engineers is unqualifiedly recommended. For ready reference, however, it might be interesting to state that in 1902 an exhaustive series of brake tests was made on the Pennsylvania Railroad, under the

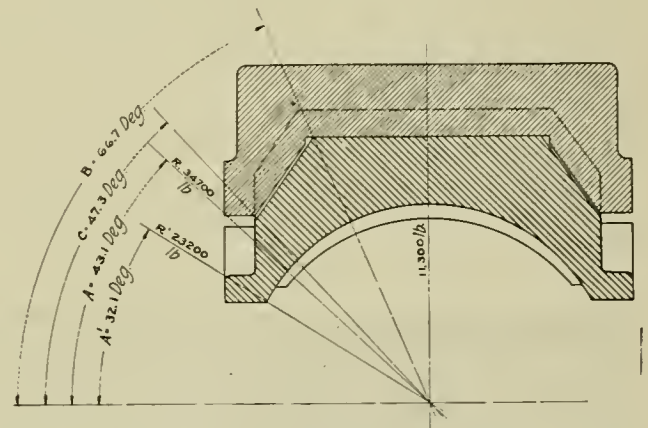

Fig. 1—Force Action on a 5-In. by 9-In. Journal; Car Weights 150,000 lb.

supervision of A. W. Gibbs, with trains consisting of one locomotive and comparatively light wooden cars, in which stops were made from a speed of 60 m. p. h. with emergency brake applications in approximately 1,000 ft. In 1903 similar tests were made on the Central Railroad of New Jersey, under the writer's supervision, in which passenger trains consisting of what was then considered modern equipment, were stopped from a speed of 60 m. p. h. in an average distance of 970 ft. Early in 1905 another series of tests was made on the Pennsylvania Railroad with equipment similar in weight and construction to that used in the 1902 and 1903 tests with substantially the same results.

The emergency braking ratio in the Pennsylvania Railroad and the Central Railroad of New Jersey tests did not exceed 125 per cent of the car weight, and a reducing mechanism was employed for automatically reducing the braking ratio during the stops, so that the mean effective ratio was approximately 100 per cent. Based upon results obtained in the three brake tests just referred to, a distance of 1,000 ft. was considered a desirable theoretical emergency stop from a speed of 60 m. p. h. for a passenger train having the ordinary "high speed brake."

In the fall of 1905, closely following the second test of

\*This paper is to be presented and discussed at the Railroad Section of the annual meeting of the American Society of Mechanical Engineers, New York, Friday morning, December 8, 1916.

the Pennsylvania Railroad, similar tests were made on the New York Central, under the supervision of C. H. Quereau. The locomotive and cars used in this test weighed, however, considerably more than the ones used in previous tests, and the emergency stops from 60 m. p. h. were over 1,200 ft., in cases where the air brake equipment and braking ratio were substantially the same as had formerly produced approximately 1,000-ft. stops with lighter equipment. Results of the New York Central test immediately established the fact that as the weights of the individual vehicles of which the train was composed increased, the braking ratio would have to be increased, if the length of the stop was to be no greater than was formerly made with lighter equipment, and to meet the requirements of the heavier locomotives and cars the air brake manufacturers immediately developed an air brake equipment with which could be had a higher braking ratio than was obtainable in previous tests with lighter locomotives and cars.

In 1908 another exhaustive series of tests was made on the Southern Pacific with still heavier locomotives and cars, in which it was found that a distance of over 1,300 ft. was required for stopping the heavier trains from a speed of 60 m. p. h. with no greater emergency braking ratio than was formerly required for making a 1,000 ft. stop with the lighter equipment.

In 1909, R. B. Kendig conducted still another brake test on the Lake Shore & Michigan Southern with trains consisting of locomotives and cars closely approximating present day equipment in weight, for which was required an emergency braking ratio of 180 to 200 per cent of the car weight for producing approximately a 1,200 ft. stop from a speed of 60 m. p. h. These tests demonstrated to the entire satisfaction of all who participated in them that the emergency braking ratio for heavy steel cars would have to be not less than 180 per cent of the car weight if the

tunate that these analyses are of a character and magnitude which preclude the practicability of reproducing them in a paper of this kind, for they show conclusively the undesirability of applying to one side of the wheel a braking ratio of sufficient magnitude for stopping the modern heavy steel equipment in no greater distance than formerly required for stopping the lighter wooden equipment. A summary of these analyses are, however, shown in the accompanying illustrations.

Fig. 1 shows a section of an M. C. B. 5-in. by 9-in. journal, brass and wedge under a 150,000-in. lb. car with an average nominal journal load of 11,300 lb. Lines  $R$  and  $R^1$  (Fig.

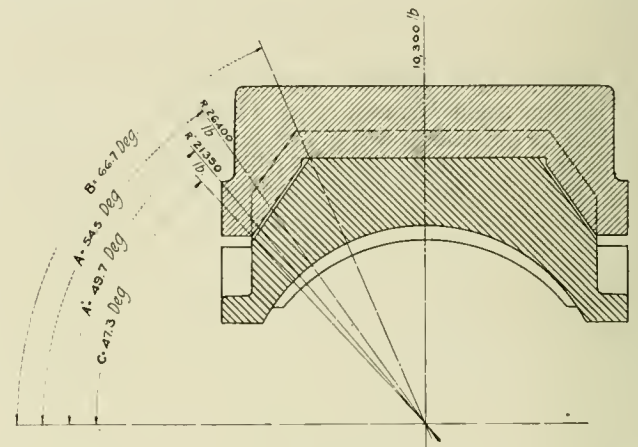

Fig. 3—Force Action on 5-In. by 9-In. Journal; Car Weighs 138,500 lb.

1) show the resultant of all loads acting on the journals with a single shoe brake, arranged in accordance with the M. C. B. recommendations for such a brake, and with an emergency braking ratio of 190 per cent. ( $R$  and  $R^1$  are for different locations of wheels and direction of rotation.) It will be observed that the lines of action,  $R$  and  $R^1$  are at a considerable distance below the supporting point between brass and wedge; that is, angle  $A$  is less than angle  $B$  and to push the journals out of the brasses during emergency braking is a natural thing to expect under the conditions stated.

Fig. 2 shows the actual displacement of journals and brasses under service conditions closely approximating those described in Fig. 1. While this photograph is made from a four-wheel truck, the brake arrangement, nominal journal load, braking ratio, etc., are, as previously stated, substantially as shown in Fig. 1.

As resultant  $R$  is affected in direction and magnitude by the distance from horizontal center line of wheels to center of brake shoes at face, Fig. 3 was made to show a summary of the analysis of the force action on journals with brake shoes suspended 10 in. from rail (8 in. below wheel centers), which is lower than M. C. B. standard. The braking ratio employed in this case is approximately 160 per cent of the car weight. Angle  $A$  is still less than angle  $B$  and displacement of journals and brasses may be expected to result therefrom.

Fig. 4 is a photograph taken at the end of a stop with the car from which the summary analysis shown in Fig. 1 was made, and seems to confirm the analysis so far as concerns the effect of the braking load on journals. There seems to have been an open question in the minds of some as to whether the displacement of journals and brasses is controlled by the difference in angles  $A$  and  $B$  or  $A$  and  $C$ ; that is, the points between which the brass is supported by the wedge seems to have been debatable, but a comparison of Figs. 1 and 2, and 3 and 4 should justify the statement that they are supported in their normal position only by the

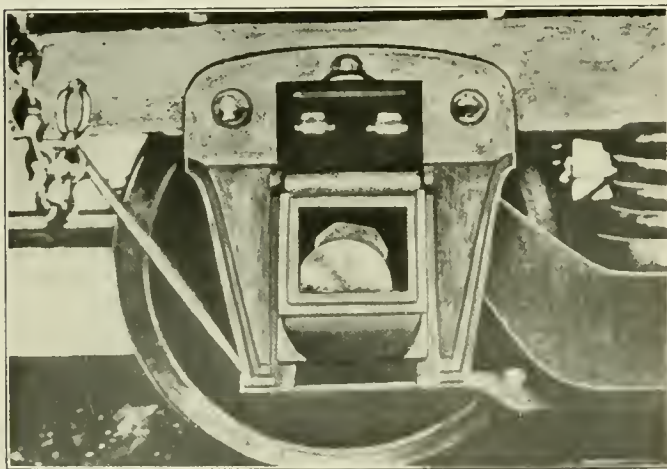

Fig. 2—Tilting and Displacement of Brasses and Journals with Single Shoe Brake; Four-Wheel Truck

emergency stops were to be made in no greater distance than formerly required for the lighter cars\*.

Realizing that 180 to 200 per cent braking power applied to one side of a car wheel would probably produce ill effects on journals, brasses, trucks, etc., the writer had made a careful and thorough analysis of the force action on car journals as affected by high braking forces, and it is unfor-

\*It is not the intention to show by the above references to brake tests the distance in which trains may be stopped in service. In conducting brake tests variations in equipment by which stopping distances are affected are necessarily reduced to a minimum, otherwise the results would not be comparative. The stopping distances referred to should, therefore, be used only as a basis of comparison for different equipments, and it should not be assumed that such stops would be reproduced in actual train service. On the contrary, it may safely be assumed that the stops with service trains should be much longer than test records show.



horizontal surface contact with the wedge, and if angle  $A$  is less than angle  $B$  the journals will be displaced.

To further check these conclusions an analysis was made of the force actions on a 5-in. by 9-in. journal of a 142,000-lb. car having six-wheel trucks, and a nominal journal load of 10,600 lb., with a service braking ratio of 85 per cent of the car weight and the arrangement of foundation brake gear the same as in Figs. 3 and 4. A summary of this analysis is shown in Fig. 5, from which it will be observed that Angle  $A$  is practically 5 deg. less than angle  $B$ , and in testing the cars out in road service, it was observed that some journals were displaced during service braking while others were not. The analysis as summarized in Fig. 5 and

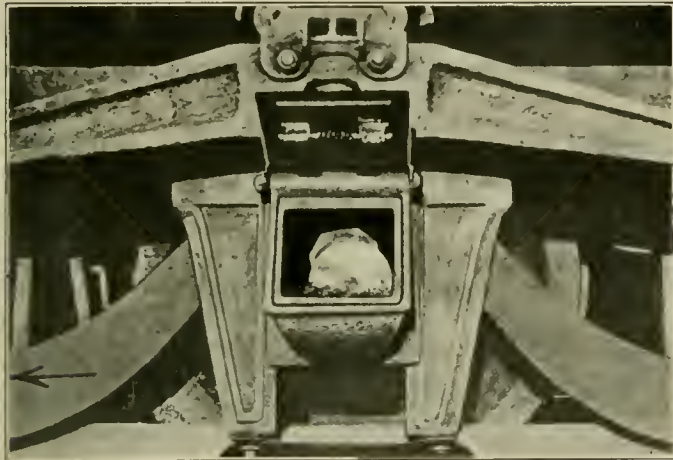

Fig. 4—Tilting of the Truck and Displacement of Brasses and Journals at Stop with a Single Shoe Brake; Six-Wheel Truck

the observations relating thereto strengthen the belief that if angle  $A$  is less than angle  $B$  the journals will be displaced. Also that where angles  $A$  and  $B$ , as determined from drawings, practically coincide there may be sufficient variations due to wear or construction of truck and brake details or rocking of brasses and wedges to change either of these angles sufficiently in service to cause the journals to be displaced or maintain a state of equilibrium.

It must be admitted that the high shoe loads applied to one side of the wheel only will produce undesirable results on journals and brasses as shown in Figs. 1 to 5 inclusive, and in addition thereto, it would seem from the discussion which is to follow that the conditions previously described are seriously objectionable from the viewpoint of train braking.

Consideration has been given to a change in brass and wedge design for the purpose of minimizing displacement of journals as referred to in the preceding discussion, but if this is done, it will still be quite difficult to stop the heavy steel car in substantially the same distance formerly required for the lighter wooden car. While on the other hand, it has been conclusively demonstrated that with a properly designed and constructed clasp brake the maximum available rail adhesion can be utilized in train braking, thereby reducing the emergency stops to a question of adhesion rather than permissible braking ratio. It is, therefore, the writer's opinion that a suitable design and make of clasp brake should be used on modern steel passenger equipment, the advantages of which are, briefly stated, as follows:

SAFETY

In case of danger, requiring an emergency brake application, a much shorter stop can be made with the clasp brake than with a single shoe brake, other conditions except those affected by the brake gear being the same in both cases.

If properly designed, manufactured and installed, there is no occasion to disconnect any part of the clasp brake rig-

ging between shopping of cars. The probability of the brake becoming inoperative through a failure to properly replace cotters when disconnecting the brake with the car in transit and the loss of brake pins resulting therefrom is reduced to a minimum.

A thin brake shoe, or the loss of a brake shoe, does not always necessitate cutting out a brake to save the brake beam.

If the clasp brake is properly designed, manufactured and applied to the car it will be practically impossible to adjust the rigging so as to impair its efficiency or interfere in any way with its proper operation.

The axles and truck frames, in addition to performing their usual functions, become safety hangers for the major portion of the brake rigging, thus reducing to a minimum the possibility of derailment that might be caused by brake rigging dropping on the track in case of failure of the truck brake gear

While the possibility of disconnected brake parts dropping on the track is greatly reduced in comparison with the single shoe type of brake gear, the danger is further reduced on account of the clasp brake parts being much lighter than those of the single shoe type.

ROUGH VS. SMOOTH TRAIN HANDLING, ACCURACY IN MAKING STOPS, ETC.

Many modern passenger trains are, on account of the inherent shortcomings of the "single shoe" type of brake, extremely difficult to handle smoothly. Careful investigation of the complaints of roughly handled passenger trains indicate that most of these troubles are due largely to non-uniform braking power and the *time in which it is developed*, as a result of improper piston travel.

In service braking at low speeds, whether for the purpose of stopping from such speeds or for completing stops from high speed, such as making a *second brake application* as the stopping point is approached, the brake power should be light and the retardation resulting therefrom must be developed slowly, or simultaneously on all cars, if smooth

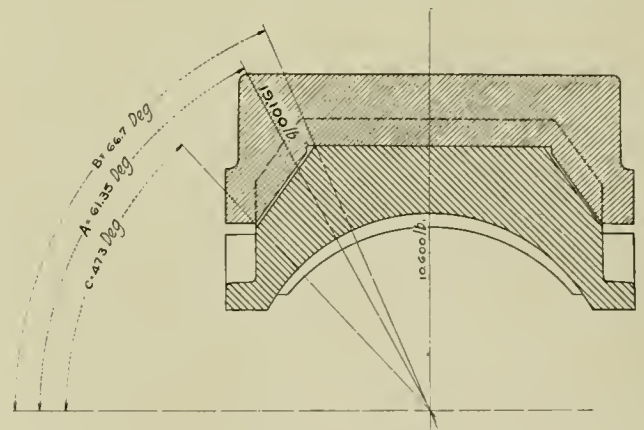

Fig. 5—Force Action on 5-In. by 9-In. Journal with Service Brake Application; Car Weighs 142,000 lb.

handling is to be insured. Smooth service stops from all speeds are also contingent upon the flexibility of the brakes.

The seriousness of slack action shocks are greater than in former years on account of the greater average weight of cars and increased length of trains, and the chances for producing them are much greater with the single shoe brake than was the case with lighter cars and shorter trains.

Contrasting the desired rate at which the braking power should be developed at low speed, making service or emergency stops from high speed in a minimum distance necessitates developing a high nominal braking power, and in addition thereto it must be developed rapidly. The rate at which both service and emergency braking power is devel-

oped is largely dependent upon piston travel, and with a view to producing the best results under all conditions the automatic brake is built on the principle of maintaining, as near as practicable, 8 in. piston travel at all times and under all conditions. As an example, if, during service braking at low train speeds, the piston travel resulting from 10 lb. brake pipe reduction is only 5 in. instead of 8 in. (with some brake riggings it is 5 in. or less) the braking power will be fully 100 per cent greater than with the predetermined standard piston travel of 8 in., and with the shorter travel a 10 or 15 lb. reduction will practically equalize the auxiliary reservoir and brake cylinder pressure, thereby materially reducing the flexibility of the brake. While the vibration of the car may cause the 5 in. piston travel to increase to practically normal before the stop is completed, it will not do so except when stopping from high speed. Moreover, if the travel does increase before the stop is completed it will contribute nothing to smooth handling, as the shock will have occurred while the travel was short.

Other things being equal, the clasp brake will develop a higher percentage of braking power than the single shoe brake during heavy service or emergency applications, but for light service braking at low speed the brake power developed from a given brake pipe reduction is much less with the clasp brake than with the single shoe brake, and it is developed at a much lower rate, thereby insuring smoother train handling than can be had with the single shoe brake.

The results just cited are due to the fact that with the single shoe brake the piston travel is practically proportional to the cylinder pressure developed, whereas with the clasp brake, with a shoe on each side of the wheel, the horizontal wheel or shoe movement relatively to the brake cylinder is reduced to a minimum, and such movement if produced from any cause will have no effect on the piston travel. Moreover, with the clasp brake the shoes are located sufficiently close to the horizontal center line of wheel centers to obviate the *pulling down* of truck frames and variations in piston travel resulting therefrom.

The removal of worn shoes and their replacement by a given number of new shoes without readjustment of slack, as is frequently done on long runs, will not affect the piston travel with the clasp type of brake to the same extent as would occur with the single shoe type of brake.

The only remedy that can be offered for the difficulties arising from improper piston travel, which so seriously affects the braking power resulting from a given brake pipe reduction and the rate at which it is developed, is to apply a truck and body brake gear that will substantially insure uniform piston travel under all conditions of speed and cylinder pressure. The use of the clasp type of brake rigging with body brake gear to suit will, to a large extent, accomplish these results and restore the flexibility of brake operation which existed prior to the adoption of extremely heavy cars and long trains equipped with single shoe brakes.

#### IMPROVES RIDING QUALITIES OF EQUIPMENT

The high brake shoe loads developed on one side of the wheels with a single shoe brake produce a binding effect between pedestals and oil boxes, which interferes with the proper action of the truck springs during an application of the brakes, and when the shoes are hung low, as is necessary with the ordinary six-wheel truck and single shoe brake, the pulling down effect of the truck defeats in many cases the purpose of the truck equalizing springs. This binding between pedestals and oil boxes and the increased load on truck springs causes the car to ride hard when brakes are applied. This does not occur with the clasp brake.

#### ELIMINATION OF HOT BOXES

With the single shoe type of brake rigging it will be observed that the high pressure exerted by the shoe on one side of the wheel causes the tilting of brasses sufficiently to lift

one side of the brass a considerable distance away from the journal (see Figs. 3 and 4) so that a wide space is open for waste to be caught between the brass and the journal when the brake is released and the brasses and journals resume their normal position. Investigation has shown that waste has been found wrapped around the journal, and that the collars on the axles are forced against the sides of the boxes. Further, these effects are not confined to emergency applications, but will also be noted in service applications of the brake and are all in the direction of producing hot boxes, while the unequal distribution of braking power and binding between boxes and pedestals has a tendency to cause slid flat wheels.

#### DECREASE IN MAINTENANCE COST AND BRAKING SHOE COST

While the principal advantages inherent in the clasp brake, of greater flexibility in service braking, etc., are outlined in the foregoing and the primary consideration for its adoption must be the increased emergency efficiency over the single shoe type of brake, providing as it does for the possibility of greatly shortened stops, with a lesser tendency to slide wheels, and consequent increase in safety, the clasp brake will also, due to the principles involved in its design and construction, show a decided decrease in cost of maintenance, not only in the brake rigging itself, but a substantial decrease in the cost of brake shoe material for equal amounts of energy dissipated.

#### COST OF TRAIN OPERATION

Investigation has developed the fact that with the single shoe type of brake on modern passenger equipment cars and the piston travel adjusted to proper limits, approximately 55 per cent of the available tractive effort of the locomotive was consumed in pulling the train against the effect of brake shoes dragging on the wheels with the brakes released. (See M. C. B. Assn. Proceedings, 1910, page 97, paragraph 3). With the clasp type of brake and the resulting increased shoe clearance, this loss is eliminated, leaving better maintenance of schedules and corresponding decreased cost of train operation.

#### CONCLUSIONS

In considering the application of clasp vs. single shoe brakes to the modern heavy steel passenger car of today the advantages of the former over the latter, as enumerated above, are but secondary to the primary question to be settled, namely: Are the present day trains to be stopped from given speeds in no greater distance than was required 10 to 15 years ago for stopping the lighter wooden cars? If so, the question of whether or not an efficient clasp brake should be used on such trains is conclusively settled. The collision energy of the heavy steel passenger train as compared to the lighter wooden train has increased directly in proportion to the increased weight, and in geometrical proportion to the increased speed, in cases where speeds have been increased, to say nothing of the increased density of traffic. It would, therefore, seem that the use of a clasp brake is essential in successfully controlling the speed of present day or future passenger trains, and without regard to nominal increase in first cost or multiplicity of parts of brake gear resulting therefrom.

The foregoing discussion on the relative performance of the clasp and single shoe brake is with the distinct understanding that the former is designed upon a scientific engineering basis and is constructed and installed in accordance with the principles involved in the design, for while the claims made for the clasp type of brake have been conclusively demonstrated by exhaustive tests and road service, it has likewise been demonstrated that where the clasp brake is improperly designed or carelessly manufactured and installed the results obtained in service are in many respects less desirable than with the single shoe brake.

# REFRIGERATING FREIGHT IN TRANSIT\*

A Discussion of the Results Obtained in Tests Made on Different Types of Refrigerator Cars

BY M. E. PENNINGTON

Food Research Laboratory, Bureau of Chemistry, United States Department of Agriculture

THE people of the United States are as dependent upon refrigerator cars for their food supply as are the people of England upon her ships. The English refrigerated food ship is the result of a systematic evolution; the American refrigerator car, like Topsy, has "just grown." The United States has now well over 100,000 refrigerator cars belonging to railroads. It costs at least \$1,500 to build a refrigerator car, and most of them are in need of rebuilding after five years of service. With such an investment and cost of maintenance, and with the responsibility of transporting fresh food to the people, we may well inquire into the efficiency of the car, and into the expense involved.

The United States Department of Agriculture, through the Bureaus of Plant Industry and Chemistry, has, for some

of life of the car. All these, and other questions are the subject of investigation in the Department of Agriculture in connection with the study of the preservation of the good condition of perishables while in transit. Apparatus and methods of investigation had to be developed to obtain the necessary data. Gradually there has been evolved an arrangement of electrical thermometers which can be installed not only in appropriate locations in the car but within the packages, and even inside an orange, peach, chicken or fish. The wires

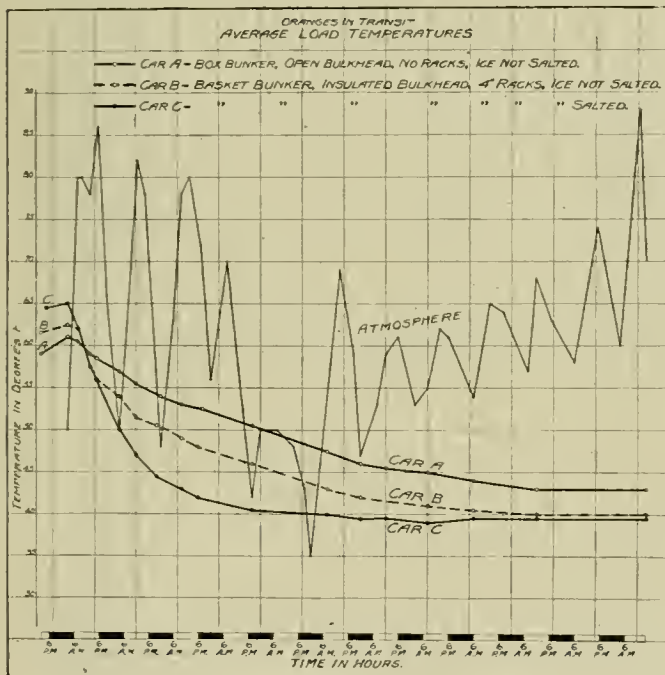

Fig. 1

years, been studying the temperatures required to preserve perishable produce in transit. The department has obtained definite information on fruits, vegetables, dressed poultry and eggs. It is now determining the most efficient and economical means of transporting these perishables. The problem is of great importance to the shippers, to the railroads, and to the consumer as well.

The efficiency of the refrigerator car depends upon such factors as the quantity and kind of insulation, the type and the capacity of the ice bunkers, the size of the car, the temperature of the entering load, the manner of stowing the packages, the circulation of the cold air from the ice bunkers, and the freedom of the insulating material from moisture. The economy of operation depends on such factors as the weight of the car in relation to the weight of the load, the amount of ice required to cool the product in transit, or to maintain the initial temperatures of the precooled load, and the length

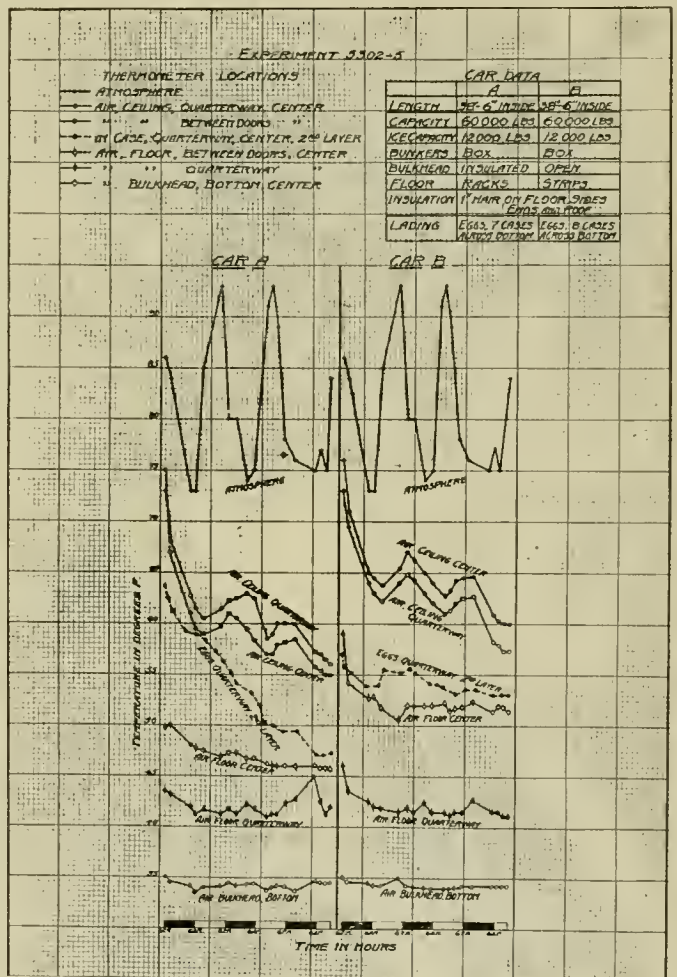

Fig. 2

from these thermometers run out between the packings of the door, and the terminals are permanently or temporarily attached to the indicators installed in a caboose.

To complete this investigation will require years of detailed study. Certain fundamental facts, however, have been established and are outlined in this paper. For example, the distribution of the cold air from the ice bunker throughout the car is vital to the preservation of the lading. The circulation of the air is produced and maintained by the difference in weight of warm and cold air. The actual difference between the weight of a cubic foot of air at 65 deg. F. (1.18 oz.) and 32 deg. F. (1.27 oz.) is only 0.09 ounces. Experi-

\*This paper was presented before the Traffic Club of Chicago, October 6, 1916.

ments with stationary precooling plants, cooled by ice or by ice and salt, have shown that the best and most economical results are obtained by hanging a basket of suitable ice capacity close to, but not actually free from the walls of the room, and closing off the basket by an insulated bulkhead open about 12 in., both at the top and bottom, to permit entrance and exit of air. In this way a large surface of ice is exposed to air contact and the air is compelled to travel over the entire column of ice before it escapes. The insulated bulkhead prevents the absorption of heat from the commodity and from the car, varying in quantity according to the distance from the ice. The bulkhead also facilitates a steady ascent and progression of the warm air in the car toward the top of the bunker. To further facilitate the distribution of the cold air, floor racks 4 in. high have been installed.

Now let us see what practical results such a combination produces when applied to a refrigerator car which is, in other respects, of the usual type. Fig. 1† shows the average temperatures in three cars of oranges in the same train in transit between Los Angeles and New York, each car containing

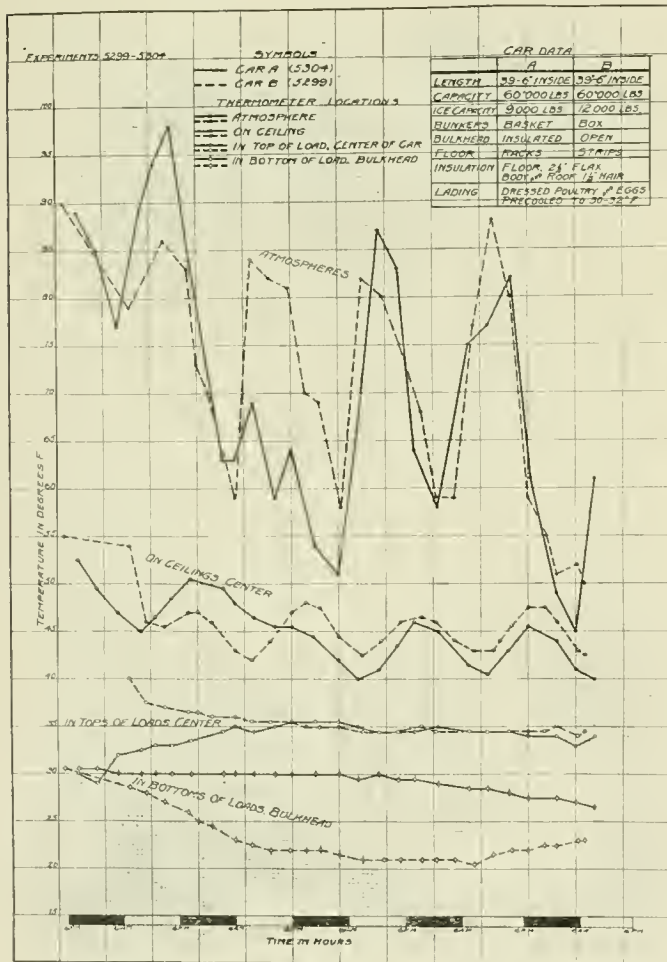

Fig. 3

462 boxes of fruit. Car A had the box bunker and open, or slatted, bulkhead so commonly seen in present day refrigerators. The lading was placed directly on the floor. Car B had a basket bunker, insulated solid bulkhead, and a rack 4 in. off the floor. Car C was of the same construction as car B, but the ice was mixed with 9 per cent salt the first day and 5 per cent of the added ice on the second. The temperature of the load in car A averaged 54.4 deg. F. The temper-

†The study of fruits and vegetables is being conducted by the Bureau of Plant Industry under the supervision of H. J. Ramsey. I am indebted to him for the data on oranges and also such other facts concerning the transportation of fruits and vegetables as are brought out in this paper.

ature of the load in car B averaged 49.5 deg. F., while car C, in which salt had been added to the ice, not only cooled the oranges more quickly but reduced the average temperature of the load to 45.4 deg. F., a gain of 9 deg. F. as compared with car A. The amount of ice placed in the bunkers in car A, including that remaining in them at destination, was approximately 23,200 lb. In car B the ice amounted to 18,675 lb., a saving of more than two tons. Car C, which had been salted, had 22,750 lb., still a little less than car A.

The results obtained with car C open up great possibilities

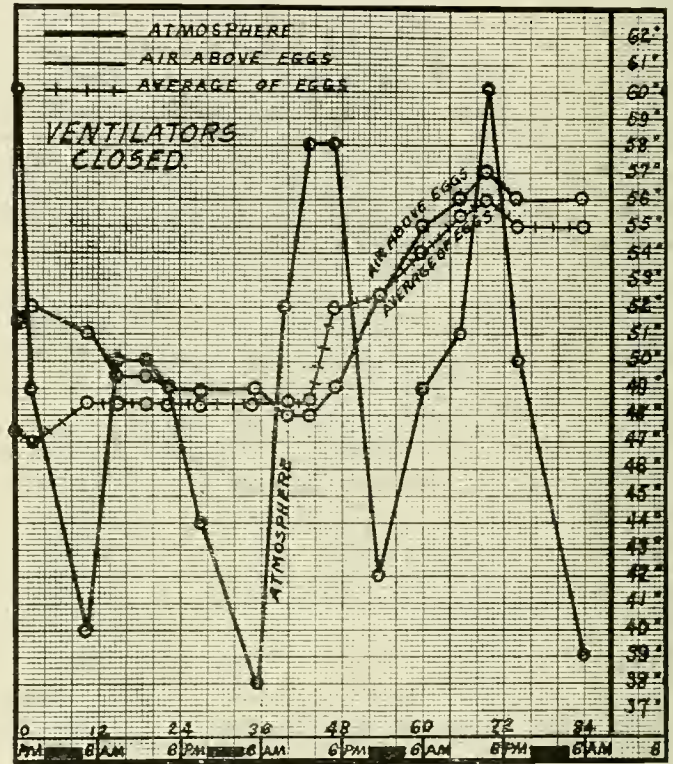

Fig. 4

in the better distribution of such extremely perishable products as strawberries, raspberries and cherries, widely produced under conditions which generally preclude proper precooling before loading into the car. The insulated bulkhead prevented the frosting of the lading next to the bunker, and the floor rack provided a quick runway for the very cold air, which soon lost its temperature of 20 deg. F., or even less, by the absorption of the heat of the lading and the car.

Such results with the basket bunker, insulated bulkhead and floor rack, combined, naturally raise the question of the relative value of each of the three factors in producing and maintaining circulation, and gaining the available refrigeration from the ice. Experimentation shows that a rack on the floor of the car hastens the cooling of the load, and affords very decided protection to the lower layer of goods against both frost and heat. The floor rack alone, however, is far less efficient than the combination of the basket bunker and insulated bulkhead with floor rack. The addition of insulation to the bulkhead increases circulation and the lading is more rapidly and completely cooled than when the bulkhead is either not insulated or is open. For example, Fig. 2 shows two cars of similar size and construction, one of which was provided with a floor rack and an insulated bulkhead, the other as commonly used. Both were loaded with eggs. The car with the insulated bulkhead and the floor rack reduced the average temperature of the load 17 deg. F. in 64 hours. The load in the ordinary car showed a reduction of 7.5 deg. F. during the same period. The average temperature of the car with the insulated bulkhead and the floor racks

was 5.5 deg. F. lower than the ordinary car. That it is not advisable to cease improvements with the floor rack and the insulated bulkhead is indicated by experiments which show that the quick cooling by ice and salt safely performed with the basket insulated bulkhead and floor rack is not possible without it. The pocketed cold air at the box bunker, which is always observed with bunkers of the box type, causes frosting of the goods against the bulkhead even when insulated.

tained an average temperature of 29.3 deg. F. at the bunker and 34.1 deg. F. in the package on the top of the load between the doors. In the one case the average difference between the warmest and coldest points in the car was 12.3 deg. F.; in the other 4.8 deg. F.

The reduction of the temperature on top layers can be increased by better and more judiciously applied insulation, especially in the roof of the car. Most of the cars in service have the same amount of insulation throughout, regardless of the additional straw on the roof during the heat of summer, and on the floor when frost protection is necessary. Experiments are now under way to determine just how much insulation it is advisable to have in roof and floors as well as in the body of the car. At present the work indicates that there is scarcely a car in the country which is sufficiently well insulated to be an economical as well as safe carrier of perishables.

A large proportion of the refrigerator cars now in service have one inch of insulating material over the entire car. Some have two inches throughout, and a few, comparatively, have had especial care bestowed on the insulation of the roof and the floor. The lack of sufficient insulation, especially on the roof of the car, has been responsible for the fact that the top layers of such fruits as peaches, strawberries and cherries are so different in quality from the rest of the carload that they must be sold as separate lots. The higher temperature of the upper half of the car has led the shippers to urge longer cars, that they might extend rather than heighten the stacks of packages. As a result of this, and also in line with a general increasing of the capacity of all cars, the refrigerator has been lengthened, regardless of the fact that heat transmission increases directly as the number of square feet of surface enclosing the car space. For example, a car whose roof, floor, walls and ends aggregate 1,170 sq. ft., and which is 33 ft. between linings, has the same amount of temperature protection with 2 in. of insulation as a car with 2.5 in. of insulation whose surfaces aggregate 1,407.5 sq. ft., and whose length between linings is 40 ft. 6 in. To determine the economical size of a refrigerator car in relation to the height of the lading, the consumption of ice, the total weight of the car and its initial cost, is an economic problem of importance. Studies to obtain such information are now in progress.

The most obvious results due to increased insulation are, first, better protection to the lading against both heat and cold, and, second, a saving in the use of ice. The modern trend in the handling of perishables is to include a precooling as a preparation for shipment, and it is a highly desirable practice from all viewpoints. When the goods enter the car at a temperature conducive to preservation, it is the business of the car to maintain that temperature. The goods need no further refrigeration, and the ice in the bunkers is required only to overcome the heat leakage through the walls. The difference in performance of a car with one inch of insulation, as compared with a similar car, except that the latter was provided with 2 in., is shown in Figs. 4 and 5. Both cars were loaded with eggs and closed without putting any ice in the bunkers. The weather at the loading point was cool enough to ensure a cool car. The possible dangers—against which the insulation was to protect—lay ahead. Fig. 4, showing the performance of the car with one inch of insulation indicates very plainly that it could not protect the eggs. Fig. 5, on the other hand, shows that 2 in. of insulation, even with higher atmospheric temperatures, delivered the eggs at destination at practically the same temperature as they entered the car, and the maximum variation was but 4 deg. The one inch car needed 10,000 lb. of ice—the 2 in. car needed none. Is it any wonder that wide-awake shippers are picking out their refrigerator cars more and more carefully?

Experimentation indicates that marked economies can be effected in the consumption of ice in transit aside from the question of insulation. Raising the load off the floor, inducing a circulation of air in the car, and bringing a large

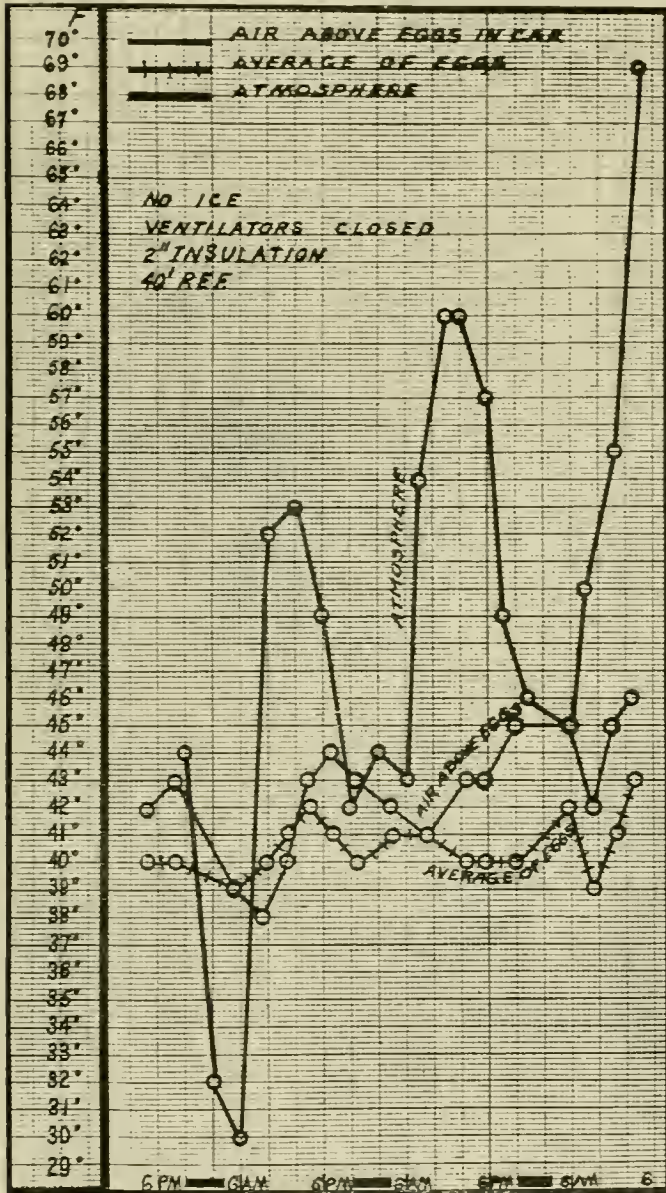

Fig. 5

The failure of refrigerator cars to maintain even temperatures throughout the load has been a serious menace to extremely perishable products. In order to produce temperatures at the top of the load between the doors—commonly the warmest place in the car—low enough to carry dressed poultry safely, it has been necessary to freeze the birds at the bunker. While freezing in transit does not injure the food value of dressed poultry, it does lower its money value at certain seasons or in some markets. Better air circulation tends to equalize temperatures, as shown in Fig. 3. In the car with the box bunkers and open bulkhead (car B), where the load was placed on floor strips, the package at the bunker on the floor froze solidly (23 deg. F.) during a four-day haul, although the package on the top of the 4 ft. load was 35.4 deg. F. A similar car (car A), except that it had a basket bunker with an insulated bulkhead and a floor rack, main-



# Shop Practice

## PLUNGER FOR HOLDING BAR STOCK

BY EDW. F. GLASS

The drawing shows a plunger for holding round or hexagon bar stock in the center of hollow spindle machines. This device is especially designed for machines having the larger diameter bore in the spindles.

In practice we have had considerable trouble in holding the material true and steady with the chuck jaws only, as the portion of the bar that extends back through the spindle would flop around, causing the material to work loose in the chucks and break the tools. This is hard on the chucks and it is impossible to get a finished or true piece of work out of the machine.

The device as shown consists of a plunger and rod. The body of the plunger is about 1/16 in. smaller than the diam-

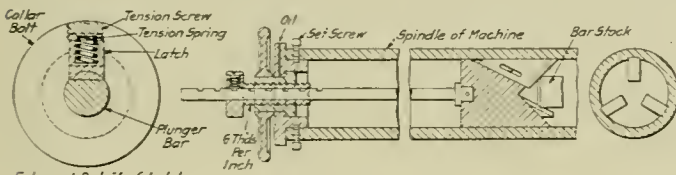

Enlarged Detail of Latch.

Device for Centering and Holding Bar Stock in Hollow Spindle Lathes

eter of the spindle, and is fitted with three segments, which come in contact with the stock in the machine, and when the body of the plunger is forced against them they are expanded against the inside walls of the spindle, thus holding the material perfectly true and solid. The adjustment device consists of a collar bushing that fits the end of the spindle, with a collar nut having a working fit on the inside of this bushing. On the end of this nut there is keyed a hand wheel. A screw bolt bored the diameter of the plunger rod is fitted in the collar nut and the larger diameter is fitted with a key latch that is held in place by a spring and cap screw to give it the required tension. In order to re-adjust this device it is necessary to loosen the hand wheel, turn the collar a quarter turn, push the plunger rod in until it engages the bar stock, turn back the collar and turn the hand wheel until the latch engages the next slot in the plunger bar; after the latch falls in, screw up by the hand wheel to the proper tension.

## OLD MAN DRILLING POST

BY LEROY SMITH

The accompanying engraving shows the general arrangement and details of an old man drilling post. This drilling post is made of soft steel, the drawing of which shows the details, and is self explanatory. One of the principal features of the post is the adjustable center, No. 3. By loosening or tightening the screws at the bottom of No. 1, this center is easily shifted laterally. This at once obviates the necessity of putting the drill in place, and center punching on the bottom of the ordinary arm so that the point or screw of the drill will not run. Another feature is the ability to adjust vertically the center of the drill. Aside from this it

also has the advantage that when the feed screw of the drill has been run out, the center, No. 3, may be screwed down and the arm, No. 1, does not need to be shifted in order to drill deeper. It would appear at the first glance that this

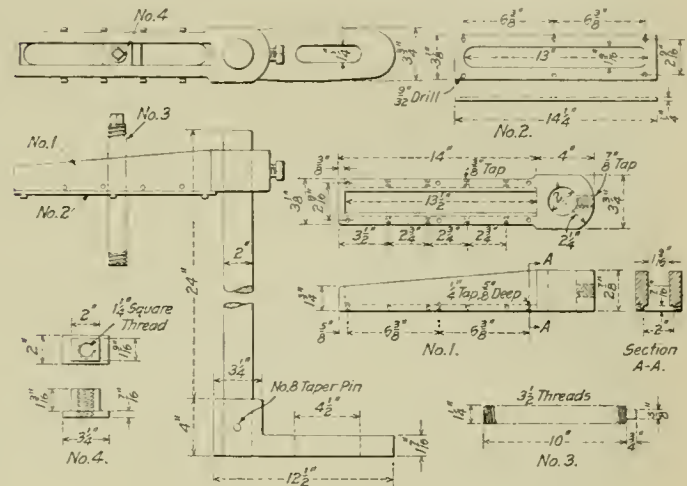

Details of Drilling Post with Adjustable Center

arrangement might possibly not be very stable, but the experience so far has been entirely satisfactory.

This device was designed by J. A. Hamburg, machinist in the Pennsylvania shops at Olean, N. Y.

## INCREASING SHOP OUTPUT

BY H. D. WOLCOMB

Throughout the country there are many railroad repair shops which overhaul from 8 to 12 general repaired engines a month. Each shop has a system for handling the work that differs in some respect from all others, yet, invariably each shop claims its system to be the best. Local conditions may necessitate, to a small extent, certain slight deviations from a uniform plan of handling general repairs. But a shop which cherishes the delusion that it is superior in all things to all others, will be found just as inefficient as the shop which admits it is out of date.

In the sense of detailed, impartial, systematic and comprehensive interchange of experience, railroad repair shops are practically isolated units. One great trouble is that the average shop foreman does not read enough in the line of his work, and invariably when he visits other shops he returns home most impressed by those practices in which his own shop surpasses, losing sight of the valuable suggestions as to where he can improve his own conditions. In the following discussion of increasing shop output, it is intended to recommend only such economies as are definite in terms and certain in results, offer suggestions that can be put into immediate operation with present shop equipments, and that will not conflict with industrial conditions or require a large expenditure of money for improved machinery. Many shops have the system of special gangs for dismantling the engine before it is placed in the erecting shop for overhauling and rebuilding. This method is economical for the large shop





# ELECTRIC WELDING IN RAILROAD SHOPS

The Field for Arc Welding Is Extensive and Its Usefulness Just Beginning to Be Appreciated

BY GORDON FOX

*Welding a Broken Locomotive Frame by the Metal Electrode Process.*

**E**LECTRIC arc welding is a form of autogenous welding. There is nothing mysterious about the use of electricity for welding, as its function is simply to produce heat, that being the sole reason for its use. In electric arc welding one terminal of a source of direct current is connected to the piece to be welded, the other terminal being an electrode in the hand of the operator. The movable electrode is touched to the article, establishing the flow of current. The arc is drawn by withdrawing the electrode a short distance. If this separation is maintained within moderate limits the arc will continue to flow between the electrode and the object and the heat of this arc fuses the metal at the point of welding.

## ARC WELDING PROCESSES

There are two commonly used arc welding processes which are distinguished by the material used in the manipulated electrode. These are most commonly called the carbon electrode and the metal electrode processes, or they may be termed, after their inventors, the Benardos and Slavianoff processes, respectively.

In the Benardos method the electrode manipulated by the operator is a carbon pencil which varies from  $\frac{1}{2}$  in. to  $1\frac{1}{2}$  in. in diameter and from 6 in. to 12 in. in length. The size of the pencil used is varied to suit the nature of the work. Special pencils for arc welding may be secured from carbon manufacturers, they being preferably of graphitic carbon which has high thermal and electrical conductivities. The carbons should be uncured. Long pencils are generally clamped near the working end in order to shorten the current path and reduce the internal resistance; as they wear away the clamping position is changed. The pencil should be ground to a point and should be maintained fairly sharp in order that the position of the arc may be controlled. With round ends the arc has a tendency to travel, especially if there be any movement of air. The carbon is clamped in

a light weight, insulated holder having a shield in front of the handle to protect the operator from the excessive heat.

The arc welding process involves the heating of the object to the proper degree, followed by the feeding in of molten metal of proper characteristics to join the parts, to fill the holes or to build up the surface, as desired. This filling material is usually introduced by melting the so-called filler rod under the arc. For wrought iron or steel, various filling materials, ordinarily Norway and Swedish iron, may be used. Bits of steel castings, boiler iron or scrap are sometimes used in place of filler rods. For cast iron, either of the above rods may be used or copper wire or special cast iron filler rods high in silicon may be best suited. A high percentage of silicon in the filler rod tends to give soft metal at the weld. The filler bar should be  $\frac{1}{8}$  in. to  $\frac{1}{2}$  in. in diameter, depending upon the nature of the work. Rods of  $\frac{1}{4}$  in. diameter are good for average jobs, and those about 3 ft. in length are as long as can be conveniently manipulated. Short rods and small bits are harder to use since they cannot be readily seen by the operator.

## OPERATOR'S HOOD

The electric arc is of intense brilliancy and injurious to the naked eye when viewed from some distance. Close at hand it is practically blinding. It therefore becomes necessary to equip the operator with a screen or hood. A window is provided, in which several thicknesses of red and blue glass are used to cut down the light and screen out the violet rays. Any dark glass should not be used as only properly selected glass will thoroughly protect the operator from eye strain. The glass used is so dense as to be nearly opaque toward ordinary daylight, but after the arc is struck, the operator can see his work quite readily. The rays of the arc have an effect on the skin similar to sunburn. Heavy gauntlet gloves and fairly heavy clothing should therefore be used; and the screen or hood must be kept in front of the

face to prevent rapid sunburn. Suitable screens and hoods can be purchased or easily constructed, and in selecting them one should be found which allows easy inspection of the work by lifting or swinging the window carrying the glass. It is desirable that, where possible, arc welding be done in an enclosure so that passers-by will not be blinded by the light, which may thus contribute to a possible accident. Also, since the arc is sensitive to air currents, all severe drafts should be shut out.

MATERIAL AND EQUIPMENT USED

The use of a flux is somewhat optional. The purpose of a flux is to protect the surfaces from oxidation, and some welders are emphatic believers in it, while others see no benefit from its use. Practice is not standardized in this respect. It is hardly necessary to use a flux when welding wrought iron or steel, but when welding cast iron the use of a flux may be generally recommended. Borax makes a good flux to which may be added about 20 per cent of red iron oxide. Many commercial fluxes are obtainable, and all may be used either dry or wet. The most satisfactory results are obtained by mixing the flux into a paste, using water, and coating the filler rods with this paste. Filler rods may be purchased in this form also. As such rods melt the flux is introduced automatically.

The arc welder who has any large volume of work to perform, particularly upon cast iron, should be provided with a suitable preheating and annealing furnace which may be heated by oil, gas or charcoal. Its use is almost imperative for many jobs on cast iron. Aside from the furnace, some fire bricks, fire clay and asbestos for molding and damming, a wire brush for removing scale and a machine hammer for peening the new metal complete the list of equipment required.

CURRENT USED

The electric power must always be direct current. For carbon electrode work, about 35 to 50 volts is required across the arc, the exact amount varying with different classes of work and different arc lengths used by the operator. It must be possible to short circuit the arc without causing

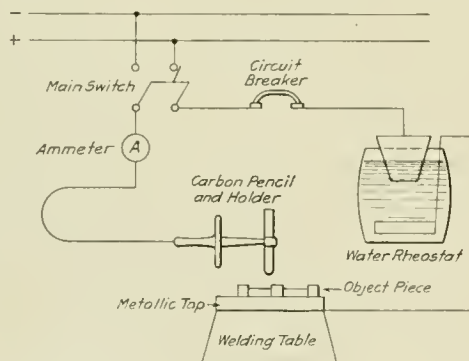

Fig. 1—Diagram Showing Use of a Water Barrel Resistance

too severe a rush of current in the feeder circuit. In the Benardos process the current required depends upon the nature of the work, amounting to about 300 to 400 amperes for average service. Thus about 15 to 20 kw. of heat is liberated at the arc for heating the metal.

If power is taken from 110-volt or 220-volt or even 550-volt power lines, resistance may be inserted in series with the arc to reduce the voltage to the desired value. This resistance serves a double purpose in that it cuts down the arc voltage and, at the same time, prevents a heavy short circuit current when the electrode is held in contact with the object previous to drawing the arc. Water barrels or rheostats may be used for this purpose, as shown in Fig. 1. Grid resistances are superior to water barrels in that

they are more portable and may be worked hard without giving trouble such as is experienced due to boiling over of water rheostats. For the occasional job, however, the water rheostat is as satisfactory as the expensive motor generator set, except that with its use the cost for current is greater. The wiring diagram illustrated in Fig. 2 shows the connections of an electric welding outfit using grid resistances.

MOTOR GENERATOR SETS

If alternating current alone is available, a motor generator set is a necessity. Such a set is also of value where the direct current is at 115 volts or higher and where a

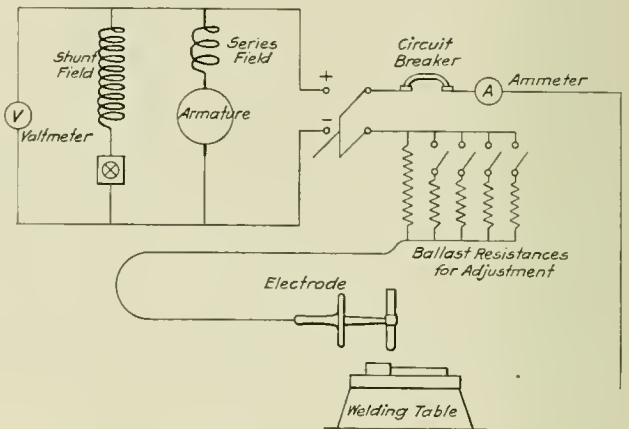

Fig. 2—Diagram Showing the Connections for a Welding Outfit Using Grid Resistances

considerable volume of work is handled, as there is considerable power lost in reducing the voltage from 230 to 50 volts by resistance. The purpose of a motor generator set is to transform the available power and deliver it in the form best suited for the welding. In a straight direct current set the only object is to save power. The justification of the investment depends upon the amount of welding work done, the character of the work, the voltage of the supply and the cost of power. Where the only available power is alternating current, a motor generator set is necessary since arc welding with alternating current can be done only with the greatest difficulty.

Two distinct types of motor generator sets are available for arc welding, different manufacturers championing different systems. In one type the current is delivered at an approximately constant pressure of 75 volts and an adjustable resistance is used in series with the arc to vary the arc voltage to suit the work in hand. The connections for the generator of such a set are shown in Fig. 2. This type of generator is particularly adapted for installations where several welders will work simultaneously. Under such conditions each welder adjusts his arc by means of an individual resistance bank on a small panel furnished for each outlet. Several welders may draw power from the same motor generator set, yet be entirely independent of each other. This type of machine does not eliminate all the resistance losses, inasmuch as the reduction from 60 volts to arc voltage is represented by resistance loss. The sets of this type which are on the market are normally capable of handling a single large carbon arc or several smaller metallic arcs simultaneously.

The second type of motor generator set is a so-called constant current or variable voltage equipment. In this system the generator delivers a variable voltage, maintaining an approximately constant current flow. For instance, when the electrode touches the object in striking the arc, the voltage is nearly zero, and as the electrode is drawn away, the voltage increases with the lengthening of the arc. A

machine of this type delivers automatically the desired voltage to maintain an arc of desired intensity. It is therefore effective in affording constancy and uniformity of the arc and, inasmuch as no ballast resistance is required, this system is more efficient than the previous one. Sets of this type are commonly built of proper size to handle a single metallic arc. Obviously, such a set can feed but a single arc since, with more than one outlet, the requirements of two welders would interfere. When carbon arc welding is to be done, two or more sets are paralleled to supply the required capacity.

#### WELDING WITH THE CARBON ARC

In the Benardos process it is necessary that the piece to be welded be connected to the positive side of the system, the manipulated carbon being the negative side. In a direct current arc the greatest energy absorption, therefore the highest temperature, occurs at the positive electrode. This may be explained by the theory that the metallic vapor in the immediate vicinity of the positive electrode is of higher resistance than that near the negative electrode. When the metal to be welded is made the positive electrode, melting should be more rapid, since the greatest heat is developed at the metallic surface. As iron and steel are more readily vaporized than carbon, with the metal the positive terminal, a greater quantity of metallic vapor is carried into the arc. This vapor has greater conductivity than carbon vapor and maintains the arc more steadily. Also, if the carbon were the positive terminal, the arc stream would carry carbon particles and vapor into the weld, making the metal hard and brittle.

In making a weld with the carbon arc, the piece to be welded is laid upon the metallic welding table in such a way that a good contact is secured. The point of welding should preferably be on top, as it is much more difficult to weld upon the side of an article than upon its top surface. Welding upon the under side of pieces cannot be accomplished by the Benardos method and can be done only after much practice with the Slavianoff method. If a large piece is to be welded it may be more convenient to simply clamp the positive lead to it at some point.

Preparation of work for welding by the carbon arc consists mainly in thoroughly cleaning the surfaces to be welded. In most cases this can be done by turning the work edge-wise or inclining it and then going over the surface with the arc and melting off all surface impurities which will run off by gravity, thus leaving clean metal. The same procedure can be followed where two pieces are to be joined, the arc being used to melt the edges of the sections to be joined so as to provide a V-shaped groove at their junction, thereby insuring that the entire joint is filled with perfect metal. Where thick sections are to be joined, it will often be found advisable to cut a groove from both sides to the center of the section. In any event it is essential that the groove extend entirely through the junction.

At the beginning of the work the arc must reach the bottom of the groove and liquefy that point first. It is impossible to reach the bottom of a narrow groove since the arc will jump to the sides. A double angle of about 90 deg. is therefore necessary. If a crack is to be repaired, it should first be recessed either by using the arc as just outlined or by chipping a V-shaped groove in it. When two pieces are to be welded together they must be first alined and clamped together or to a third piece. If a one-sided heat is to occur, some allowance must be made for unequal contraction. This part of the work calls for experience. If it is desired to build up new metal to any height, a mold must be made to retain the molten material which may be made of asbestos or fire clay.

The preliminary work being completed, the welding may be started. The resistances are adjusted to the estimated

proper values, the operator touches the carbon to the object and draws his arc. The arc should be made fairly long, particularly at the beginning of the work. A long arc increases the energy and heating, and at the same time distributes the heat better. A very short arc hisses and is likely to produce a hard, brittle weld. The proper length of the arc depends upon the size of electrode and nature of the work, but may be from one inch to over two inches. If the arc cannot be drawn to this length there is too much ballast resistance. If the arc is too fierce and the current too high, the ballast resistance is too low. It is well to use an ammeter always so as to observe what current is most effective for different kinds of work. By remembering previous conditions it will be possible to always work under the most favorable conditions.

The arc is moved with a rotary motion from one side of the piece to the other in order to distribute the heating uniformly over the zone to be welded. When melting temperatures are reached the arc is confined more to the center of the groove and the filler rod is brought into play to start filling in, care being taken to see that the new metal adheres and flows into the metal of the side walls. As new metal is added the groove is filled and the point of action is moved forward. The arc is kept in motion all the time, however, a circular swing being most effective. If flux is used for the work and this is not supplied in the filler rod it may be shaken into the weld from time to time, a can with perforated cover forming a convenient means. As soon as the weld is completed the electrode is laid aside, the hood removed and the new metal given a thorough peening to make it more dense and improve the grain. The work of welding should, if possible, be done in one continuous heating in order to prevent formation of oxide and for other reasons. A heavy piece may be welded from two sides, in which case each side would be hammered before turning over.

#### WELDING WITH THE METALLIC ARC

The metal electrode or Slavianoff process is, in most respects, quite similar to the carbon process. Instead of the carbon pencil a smaller metallic pencil is used which also forms the filler rod; it melts away and enters or builds upon the object as the welding progresses. A lower voltage and shorter arc are used for this method. The arc is only about  $\frac{1}{8}$  in. to 3-16 in. long, while the voltage at the arc is about 18 to 30 volts. The current used will be about 90 to 200 amperes, according to the size of the pencil and the character of the work. The pencils are from  $\frac{1}{8}$  in. to  $\frac{1}{4}$  in. in diameter and about a foot long. A small, light holder is used, being arranged to grip the pencil through a cam or other clamping arrangements, so that new pencils may be quickly inserted as the old ones are consumed.

Preparation of work for welding done by the metal electrode arc is in most respects similar to that for carbon arc work. For many classes of work, in fact, the carbon arc can be used to prepare the work for repair by the use of the metallic arc. The first essential is that of absolute cleanliness of the work, all traces of oil, scale, rust, etc., being thoroughly removed before welding is begun. Where flues are to be welded to flue sheets in locomotive fireboxes, this cleaning can be very satisfactorily done by use of a sand blast which, if properly used, leaves the flues and sheets in condition for welding without further preparation.

Before attempting to repair work such as cracked firebox sheets, broken frames, etc., it is necessary to provide space for the metal to be added, just as is the case with the carbon electrode process. Where a crack is to be repaired the sheet should be cut along the line of the crack, into a V-groove with an angle of about 90 deg., the sheet being cut entirely through and the width at the bottom of the groove being approximately 1-16 to  $\frac{1}{8}$  in. The cutting may be done either by a chisel or by first using the carbon arc to

cut the groove, then using an air chisel to clean up the sides and remove all of the melted surface.

Where welding is to be done in a vertical plane as would be the case where vertical cracks are to be repaired on firebox side sheets, or the vertical sides of a patch in the firebox, the welding should be begun at the bottom of the groove. The metal added is then built up on top of that previously deposited, and with reasonable care sound welds are assured.

In filling in cracks, welding patches, etc., practice differs as to whether to fill the entire groove at one application of the arc or whether to first fill the bottom of the groove and later add enough metal to finish the weld in a second course. Either method should give satisfactory welds providing proper care is taken by the operator to assure a thorough junction between the sheets and the new metal. Where welding is done in more than one course, care should be taken to see that all particles of oxide or slag are removed from the surface of the preceding course, as well as from the edges of the sheet. This can best be done by the use of a stiff wire brush.

Where long seams are to be welded, as for example, in welding in a half side sheet, practice again differs as to the best method of taking care of expansion. Some operators prefer to allow for expansion by widening the gap between the sheet, this being done by setting the new sheet away at a slight angle; the allowance usually made by these operators is about  $\frac{1}{8}$  in. to  $\frac{1}{4}$  in. per foot of length. Then when the weld is begun at one end and the work is carried on, the two edges will gradually draw together, due to the contraction in the weld at cooling. Other operators prefer to place the two edges in final relation to each other, holding them at the proper distance apart by means of "tacks" at intervals of 12 in. to 18 in. The weld is then begun at either end and as it approaches a "tack" the tack itself is cut out by use of a chisel and solid metal welded in, the tack simply serving the purpose of holding the sheets in proper relation until the weld is made. When tacking is used, it has often been found advisable to weld a short space, say six or eight inches, from one end of the seam, then go to the other end of the seam and weld a like distance, thus keeping heating and expansion at a minimum.

In any event, troubles from expansion will be found at a minimum where the metal electrode arc is used as while the heat at the weld is very intense it is also very concentrated so that the total heat tending to expand the metal surrounding the weld is a minimum.

The object is commonly made the positive terminal, as in the Benardos method, although it is possible to reverse this relation with quite satisfactory results. Reversal of the connections causes the metallic pencil to become the point of greatest heat so that it melts away quite rapidly and may deposit upon the object when the latter is too cool. Reversal of connections, however, may be convenient in some cases, as, for instance, field work in an electric traction system where the power is taken from the trolley. Under such conditions, if the object is made positive, careful insulating arrangements are necessary. If worn frogs or crossings are to be built up, the object is of necessity the negative terminal.

Since the metallic arc is less intense than that with the carbon electrode, the hood may be dispensed with, but a screen is still required and gloves must be worn. The material for the filler rod may be Norway or Swedish iron or Bessemer steel. The first mentioned is recommended. Pencils coated with flux may be purchased, otherwise flux may be shaken into the weld from time to time. Little flux need be used when welding by this method.

The process of welding with the metallic electrode is much like that using the carbon electrode, but since the arc is so short, a steady hand is required to maintain it. A little withdrawal of the pencil causes the arc to go out, while touching the object piece may cause the pencil to adhere.

Supporting the arm helps to keep the hand steady. The pencil and the point of application should both be molten simultaneously and the movement of the pencil and length and intensity of the arc must be adjusted to obtain this condition, otherwise a good weld is not secured. Lengthening the arc slightly increases the heating at the piece. Inasmuch as metal is being constantly melted off and deposited, the pencil must be kept in gradual progression to prevent piling up of the metal in one spot. It requires considerable practice to obtain the right heat and right deposit simultaneously. A weld made by the metal electrode process does not usually require hammering as the grain is found to be closer and better than when the carbon electrode is used, but a little hammering does no harm, if done while the weld is still at red heat.

#### ALLOWING FOR EXPANSION

The process of melting and filling in the metal does not comprise the entire art of welding, as properly allowing for expansion, contraction and warping is a most important feature. In the case of castings particularly, difficulty is sometimes experienced due to cracking while the piece is cooling. The crack is most likely to occur at the weld, although pieces not infrequently crack at an adjacent point. Cracking may be caused by poor welding due to dirt or oxide or carbon from too short an arc, but it is more likely due to the shrinkage stresses incident to cooling. Any piece is larger while hot than when cold, consequently if a portion of a casting is hot and a portion cold it is easy for great strains to be set up. Cast iron will withstand little tensile stress, hence it cracks as the stresses incident to shrinkage are of great magnitude. To avoid shrinkage stresses is part of the art of welding, and considerable study may be given to this feature. Shrinkage troubles may be materially relieved if the casting is brought to a red heat before welding; then, after the work is completed, it should be allowed to cool slowly in the furnace or buried in lime or mica dust. Slow cooling is also necessary to secure soft metal in cast iron work. If an ordinary casting, when poured, is allowed to cool quickly, it becomes chilled iron, hard and brittle, likewise the cast metal flowing into a weld will become hard if cooled rapidly. It is easy for a weld to be chilled quickly as there is heat conducting metal all about it which will rapidly absorb its heat; hence the desirability of annealing.

#### TEMPERATURE OF THE ARC

The temperature of the electric arc is estimated at 6,300 to 7,200 deg. F., it being the hottest flame known. The arc is therefore applicable to the melting of all metals. In practice, however, electric arc welding is most effective for work on wrought iron and steel. Welds in cast iron are not always dependable, and may be hard if carbon is allowed to enter the metal from a short arc or if the piece is chilled. Malleable iron, which is malleablized white cast iron, cannot be dependably welded by any process. When welded it loses its malleability because of the heating and filling, and returns to its original state as white iron, hard and brittle. The electric arc is also ill-suited for welding brass and bronze as it is too hot and vaporizes portions of the alloy.

#### STRENGTH OF WELDS

The strength of electric arc welds is usually about 70 per cent of the strength of the metal, assuming that cast steel is being welded. With machine steel the weld should be of 80 per cent efficiency. The metal which goes into the weld is really in cast form, although its grain may be improved by hammering. In many cases the strength of the weld is not of prime importance, as when filling holes, building up worn surfaces and similar work, but if the strength of the weld is important it is often possible to make up in quantity of metal what is lacking in quality by building on extra

metal at the weld and over the adjacent section. Metal may be added or built on by the arc process with impunity and to a nicety.

BENARDOS VERSUS SLAVIANOFF PROCESS

Each method of arc welding finds its advocates. The Benardos process was originally most used, but the Slavianoﬀ process is probably more popular at present. The Benardos process affords greater heat volume and is best suited for heavy work where speed of application is desirable, and where the quality and finish of the weld are of secondary importance. The Slavianoﬀ process usually gives a more reliable weld, gives finer texture to the metal, leaves it less porous, can be more neatly executed and finished, requires less power and may be easier controlled. The Benardos process is well suited for filling holes in large castings and similar work, but the Slavianoﬀ process is best for building up metal on surfaces since the addition of metal is largely automatic and the confinement of the heat avoids flowing and run-off tendencies; in other words the added metal stays where it is put. With suitable control provisions, it is possible to combine methods, heating the working zone by the use of the carbon arc, and building up the new metal with the metal electrode, the procedure depending upon the character of the work and the ability to reach the molten condition simultaneously upon object and electrode.

FIELD FOR ARC WELDING

The field for arc welding is extensive and is rapidly widening as the usefulness of the process becomes realized. It is particularly well suited for repair work, as it is flexible and adaptable. In the railroad shop arc welding is extensively used for welding breaks in locomotive and car frames, the work being done with a minimum of dismantling. Worn parts are frequently built up by the addition of new metal. Arc welding has been successfully used for the building up of flat spots on steel driving and car wheels, which avoids the life reduction incident to turning down the entire wheel. Welding the ends of flues is being recognized as superior to heading or expanding. This work is done with the metal electrode. In addition to these specific applications many individual jobs of all sorts are subject to advantageous handling by this method.

In flexibility or character of workmanship the arc process is not superior to the oxy-acetylene flame; in fact the gas process is more flexible and is considered by some workers to be better upon cast iron. For work on brass, bronze or aluminum the oxy-acetylene flame has no competition. The acetylene flame is also somewhat easier to handle as glasses alone are required, no hood or screen being necessary. The main point of superiority of the arc method is its economy, as the electric arc produces the necessary heat at a much lower cost than does the oxy-acetylene flame. In its field the arc also produces results as good, if not better, than can be obtained with gas, i. e., flue welding. To avoid excessive cost, preheating is almost always necessary in gas welding, but may often be dispensed with in arc welding. The cost of electric power for a welding job will only be from 15 to 25 per cent of the cost of oxygen and acetylene for the same job.

TYPES OF ELECTRIC FURNACES.—Different types of electric furnaces, whether for laboratory or for commercial use, may be classified according to the methods employed to transform the electrical energy into heat in the material. These are: By passing the current through the metal to be treated, so that the metal forms a part of the circuit; by passing the current through a resistance material, the heat thus produced being radiated and conducted to the metal; by surrounding the metal with an alternating-current circuit, so that eddy currents are produced in the metal, these currents generating the necessary heat.— *American Machinist*.

CYLINDER HEAD GRINDER

BY J. LEE

The cylinder head grinder illustrated consists of seven pieces; a cylinder cover driving arm, a piston valve cover spindle and pump bearer, an operating lever, a steam end of a standard 9 1/2 in. Westinghouse air pump with a special rod fitted, a long 1 in. rod, a coil spring, and a bar 1 in. by 3 in. To grind in a cylinder head, the stuffing box glands are removed and in place the driving arm and pump bearer are bolted on, the piston valve cover of course being securely bolted in place, and the cylinder cover being free to turn.

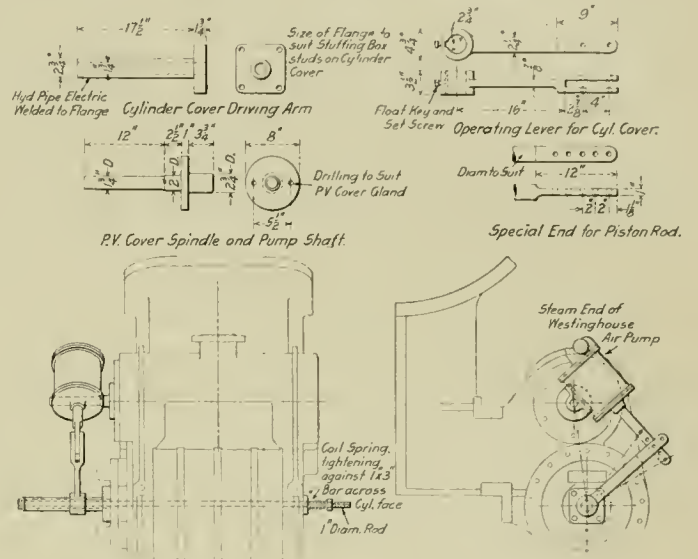

Cylinder Head Grinder Made from an Air Pump Cylinder

The driving arm is hollow to allow a one inch rod to pass through. This forms a means of applying pressure between the cylinder and cylinder cover faces, the nut on the rod screwing up to a coil spring which is supported by a bar placed across the cylinder face. The piston rod and operating lever are connected as shown, and the arrangement is then ready to operate.

ENGINEHOUSE PRACTICE\*

BY J. F. DONELLON

To be a successful enginehouse foreman, a man must be able to perfect an organization that will take care of every detail. The foreman who trains his mechanics to be specialists will be more successful than the man who permits every Tom, Dick or Harry to set valves, file brasses, line guides, etc. Most enginehouse foremen select their best men for passenger engine work, and if these men are properly trained they will take a personal pride in the performance of engines, and the engine failure sheet will be blank so often that when there is a failure it will give everyone the blues.

The best way to avoid engine failures is to have a 100 per cent. organization, locomotives as nearly as possible of one class, and get all the men interested. The latter can be done by telling them of some failure that was just barely averted by the quick action of the engineman, the cause being careless work or inspection, and by posting the engine failure sheet in a conspicuous place, so the shop men can read it. They will become familiar with the petty defects that cause engine failures, as well as the break-downs, will make every effort to tighten up on their inspection, and do better work.

There should be a machinist assigned to take care of piston rod and valve stem packing, keep oil swabs in condition

\*Entered in the Engine Terminal Competition.

on both piston rods and valve stems, keep guide oil cups in good condition, and report the condition of the guides.

In a good many engine houses guide cups are given very little attention, especially on pooled engines. Some are in service with tops missing, allowing sand and grit to partially fill the cup. This results in the babbitt metal on the cross-head wearing out very quickly.

There should be a regular man assigned to reduce or refit main rod brasses, especially on passenger engines. Engine-men as a rule are very finicky on this point, and if a good, reliable man reduces a main rod brass it gives the engineman greater confidence, with the result that he makes a better run.

Alongside of the inspection pit there should be a tool house where the supply men, after removing all tools from the engine, can store them until the engine is called. While the engine inspector is inspecting the engine, the man who fills the grease cups is doing his work, and the man who looks after head lamps and classification lamps is busy performing his duty, so that when the shop men have finished the engine-house repairs, all that is necessary to be done is to equip the engine with tools and supplies.

### ECCENTRIC KEYWAY CUTTER

BY E. A. MURRAY

Master Mechanic, Chesapeake and Ohio, Clifton Forge, Va.

The machine shown in the drawing overcomes many of the difficulties which were encountered in drilling and chipping out keyways in axles. It consists of a cast iron base which is clamped to the axle by means of chains and set screws. This base carries and guides a support and guide

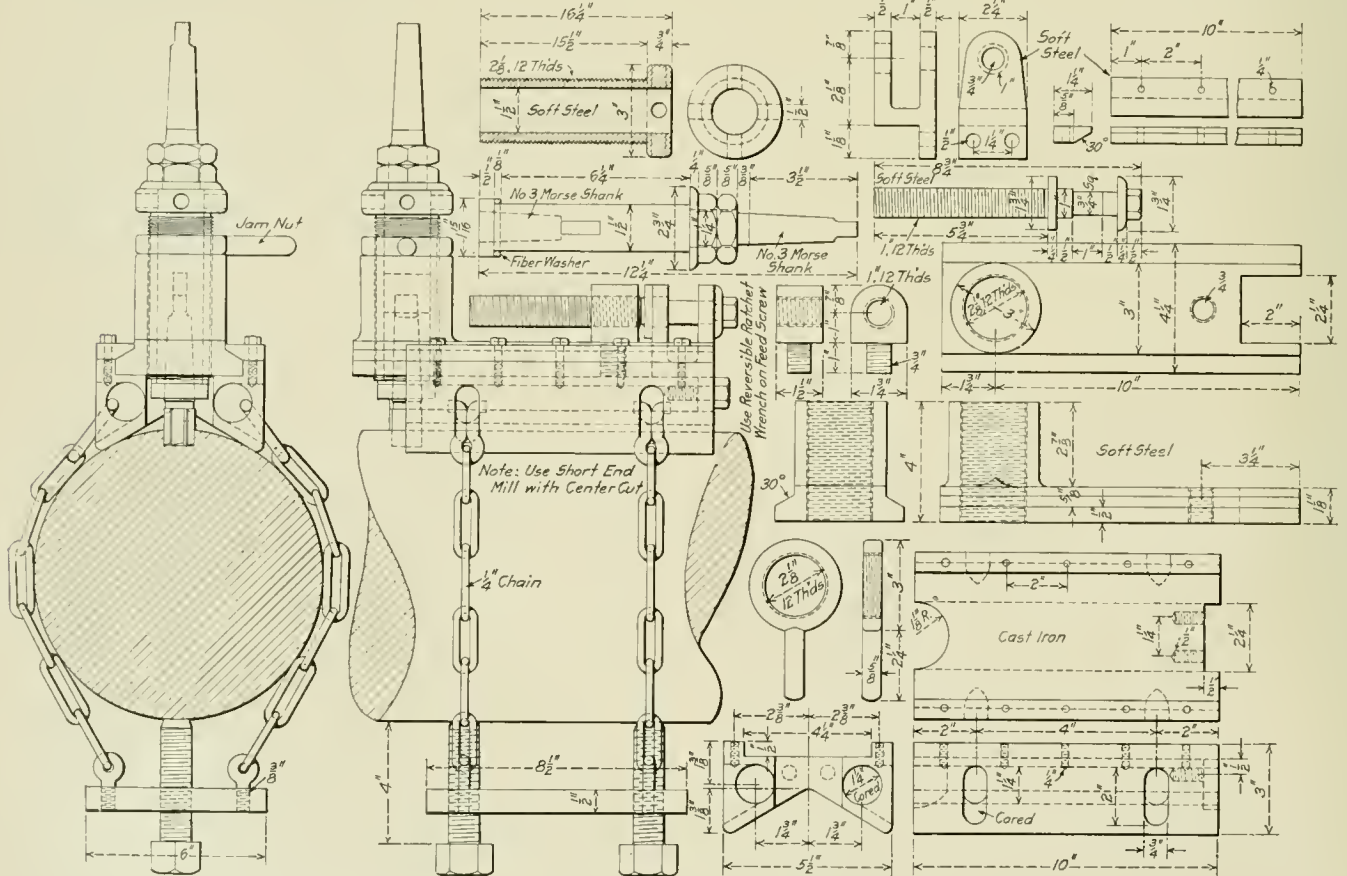

Machine Used on the Chesapeake & Ohio for Cutting Keyways In Axles

for a short end mill. The support is made of soft steel, with a soft steel bushing for the mill socket, which has No. 3 Morse taper for both the mill and the driving motor. The mill is moved by means of a horizontal feed screw, attached to its support and adjusted by a reversible ratchet.

### COMBINATION PNEUMATIC SPRING SHEAR AND BENDER

BY J. H. CHANCY

Foreman Blacksmith, Georgia Railroad, Augusta, Ga.

The illustration shows a combination pneumatic spring, punch and bender which has been recently constructed for use in the spring making and repairing department. It is

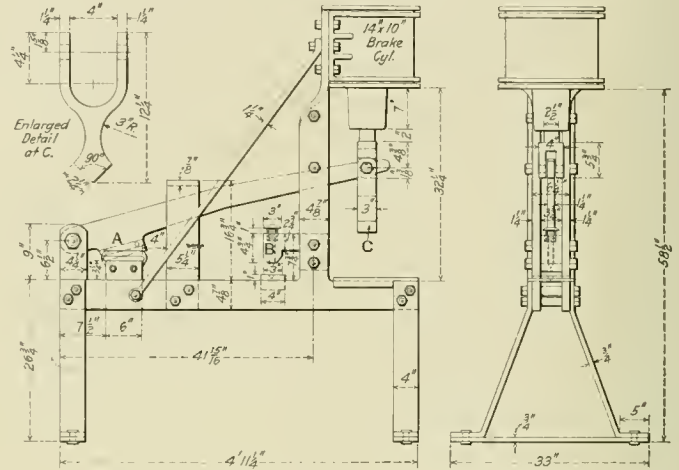

Details of Spring Shear and Bending Machine

located conveniently to the spring maker's fire, and is used for turning the ends after they have been tapered at the shear A, and for cutting old plates that are often reclaimed.

The punch shown at B is used for titting the springs and the plunger C is used for bending them. The arrangement is made up from material that may be obtained in any shop, a 14-in. by 10-in. air brake cylinder being used for the driving medium. This machine has saved time in spring work.

# TRAINING YOUNG MEN FOR PROMOTION\*

Santa Fe Method of Picking and Training Recruits  
for Its Future Mechanical Department Officers

BY F. W. THOMAS

Supervisor of Apprentices, Atchison, Topeka & Santa Fe, Topeka, Kans.

THE training of young men for positions of responsibility involves two considerations; the foundation upon which to build and the material with which you are to build. The solution of both of these by the Santa Fe requires a little explanation of the preparation of the raw material from which we may select the stones for the building. Our apprentice system was organized nine years ago and developed along the lines promulgated by G. M. Basford. We do not claim the credit of originating the scheme. We do, however, claim the honor of having put his idea into practical effect, standing by the scheme and backing it up until the infant could stand alone, and today we are reaping some invaluable results—results you cannot measure in dollars and cents.

## THE APPRENTICE SYSTEM

Briefly, our scheme for training boys for our shops, is as follows: We take a boy who has completed grammar school or better and examine him as to his mental make-up. A series of simple arithmetical problems, coupled with the manner of filling out his formal application blank, and a personal interview, give us some idea of the boy's accuracy, industry and alertness. He then goes out in the shop to run the gauntlet of our shop instructors. They find out why he wants to be a machinist instead of a lawyer, or a boiler maker instead of an editor or preacher, if some friend or parent simply sent him to us on account of the good wages paid mechanics, or if he is making application simply because his father was a machinist. We want to find out as much as possible about the boy from the boy himself. We do not ask any letters of reference. We do, however, strongly endeavor to get boys of good, honest parentage. If he passes the shop instructors he next goes to our surgeons and passes a physical examination. We are taking these young fellows in our service for life, and it is well that young men sound in body and mind should be selected.

If the doctor passes him the boy goes to the office of the superintendent of shops, filling out the regular indenture papers and minor's release, is given a letter to the shop foreman, who gives him a shop number, etc., and he is told to be on hand by the time the whistle blows in the morning. He enters the shop next morning. He is not left to wander around or to wait for someone, or to be bewildered by a sea of strange faces, or frightened by whirling belts, moving machines, or unaccustomed noises. The shop instructor meets him, a kindly hand grasps his, a kindly face is looking upon him, a kindly voice is speaking to him. Then a feeling creeps over him: "What a glorious and good world this is"—an exhilarating feeling which each of us has felt the hour we began to work for ourselves.

The apprentice in the shop is constantly under the eye of the shop instructors and is taught how to perform each operation or step of the trade he has been indentured to learn. An exact account is kept of each job performed and the time required to perform it. His shop work is correlated with useful instruction in the apprentice school room. We teach him mechanical and free hand drawing, the elements of mechanics, shop arithmetic, and some other subjects, closely related to his actual shop work. A boiler maker apprentice,

for instance, will have acquired a working knowledge of plane and descriptive geometry. He will be able to give you an intelligent definition of a boiler, the correct name and function of each part. He can calculate the strength of any kind of seam, can figure out the factor of safety of a boiler or any part of it; from a flat sheet he can lay out, mathematically or geometrically, any section and develop it. He is familiar with the Federal rules as to the inspection and maintenance of boilers. He can quickly make you a sketch or a working drawing of a boiler, can lay out, flange, stay, and build a boiler. At 21 years of age he is the equal of a boiler maker of 50 years. Throughout his four years apprenticeship he is hourly watched by general and shop foremen, by shop and school instructors. His weak points are strengthened, his strong features are exercised. Personal characteristic blanks are filled out from time to time which give the supervisor's office a graphic personal record. While the boy is serving his apprenticeship we find out his particular fitness, firmly convinced that the boy, now a man, will perform his duties better when his heart is in the work; if he can be placed on a class of work which he loves, he will certainly do better than if engaged on some work which he does not like.

## RECRUITS FOR PROMOTION

The best worker will not necessarily make the best foreman, this we have long since learned. Those who have given evidence of possessing talent for leadership are selected for development. Possibly and very probably not all deserving ones are selected, but we are pretty sure that only those are selected who have given evidence of such ability. This is our first source of supply. The second is from our special apprentices, who are graduates of engineering schools.

Special apprentices are selected only upon a personal interview. We cannot put much credence in letters of recommendation from professors or influential friends. I do not mean by this that they attempt to deceive. The trouble lies in the fact that they are not really and fully acquainted with the young fellow. There is little or no effort made by our college instructors to find out the real natural talent of the student. We require these specials to work one year on machines, and one year on erecting floor, then we decide whether or not he shall pursue our course for the development for positions of responsibility.

We now have the boy from the public schools who has served his four years journeyman apprenticeship and has become a first-class mechanic, and the college man who has engaged in practical shop work for two years; the pick of two sources for development into our future officers. They must, during their apprenticeship, have been quick to learn, industrious, prompt, honest, readily and effectively amenable to discipline, steady under fire, and popular with officers and associates, and then have some distinctive qualities of leadership.

## TRAINING FOR FUTURE RESPONSIBILITY

We offer each of them the following opportunity: He must serve two months in the boiler shop, familiarizing himself with tubes, stays, patches, front ends, Federal laws, etc., pursuing a course of reading and study of boilers and appurtenances. He next goes to our freight car shop and serves

\*Abstract of a paper presented before the New York Railway Club, October 20, 1916.

two months on trucks, draft gears, body, doors, roof, air brakes and inspection, also pursuing a course of reading and study on car work, M. C. B. rules, etc. Then we send him to a busy roundhouse for four months. He may previously have had roundhouse work but he is now taught the operation of an engine house from the time a locomotive reaches the ash pit until it is headed out on the "ready to serve" track. Cleaning fire, fueling, watering, actually repairing, the handling and distribution of work orders or slips, dispatching, and the various reports made out by the foreman, etc. Here he reads or studies some good books on locomotives. We next find him with the travelling engineer, studying fuel economics, learning to fire, to inspect and operate the engine, to make out the usual road foreman's report, accompanied by an individual study of parts of the machinery, the construction and operation of injectors, lubricators, safety valves, air brake, valve motion, etc. He also familiarizes himself with the Federal and company rules for the inspection and care of locomotives. We next find him at the front door of our back shops or a large roundhouse, for thirty days engaged in inspecting incoming locomotives and thirty days inspecting outgoing locomotives. Once a month he has written a letter covering the work he has done, explaining the operation of certain features, offering suggestions as to shop management or methods, and criticizing local existing conditions when he can offer some remedy. In each branch of the above he must answer 150 questions bearing on the work in hand.

This is called our Special Course For Graduate Apprentices, and it keeps them terribly busy. They are the very busiest young men I know. We have so made this course that it is a trying and severe one, but it is certainly a developing one. A few break down under it or throw it up, but 80 per cent or over pursue it to the end. We do not expect that the two months in the boiler shop will make a boiler maker but we do know it gives an insight into boiler work which will be of vast benefit to the young man when he is made a roundhouse or shop foreman. We don't expect him to become a proficient car carpenter in 60 days, but he has derived sufficient knowledge of cars, car repairing and inspection, and M. C. B. rules to be not entirely dependent upon the car foreman's word or opinion, and so on through the course. It is surprising how much these bright young mechanics can pick up and assimilate of the other trades during that short period. The course of reading, study, and examination questions does not leave much time for the movies, even his best girl will suffer. But we are making men.

The Good Book tells us that God spent nearly the entire week in creating the entire animal, plant, and vegetable life of the world, before He made man. While we have spent nine years in organizing and building up our present apprentice system, it has been less than two years since we have attempted to specifically train men for our future mechanical officers.

#### OPPORTUNITY FOR OUTSIDE TRAINING

To prevent any possibility of our growing stale, we pick a number from this list of special course men and send them east. One year ago we brought six machinists and one boiler maker to the Baldwin Locomotive Works for a period of six months, where they were made assistant department foremen. They were given as much responsibility as they could carry and were changed from one department to another every two months. They acquired a general and detailed knowledge of the plant, executive and operative, from the time the material for a locomotive was ordered and received and on through the plant until it left the works a finished locomotive. They had an opportunity to note the practices of nearly all the roads in this country and many foreign nations. They were given, through the liberality of the Baldwin Locomotive Works, an opportunity of visiting a steel mill and studying the manu-

facture of steel. They were likewise treated with two half days at the Master Mechanics' convention at Atlantic City. I wish publicly to express my appreciation to Mr. Vauclain and his officers for their personal interest and zeal in furthering a scheme which I believe is the best that has been advanced. Every two months the speaker was required to visit these young men in Philadelphia. It is a long way from Kansas to Philadelphia but the Santa Fe believes there is no trip too long or no work too hard, when it comes to developing young men for her service. These young men are back home again. They were not spoiled; they went back to their trade in the shop, but for a few days only. One is foreman of our Dallas terminal, one a roundhouse foreman in Kansas, one in Arizona, one machine foreman in Topeka, one welding engineer in charge of gas and electric welding and one machine foreman in California, all doing well. Seven more have taken their places at Baldwin's.

In like manner we sent four graduate apprentice passenger car men to the Pullman shops to catch on to the latest and best in steel car construction, two young painters to the Pullman shops to acquire the newest and best in painting, graining, and decorating steel passenger cars. Four young fellows are at the Westinghouse Air Brake Company, mastering the manufacture of air brake equipment. The same generous spirit has been shown by the Pullman and Westinghouse companies as was exercised by the Baldwin Locomotive Works. The four car men are back with us, filling positions of responsibility.

Each of the above young men was required twice a month to write me a letter giving in detail their observations and work during the past two weeks. These letters were remarkably interesting and will be of untold benefit to the young men in after years. The training this letter writing gave them could not be obtained so effectively in any other way. It required from two to five days a month for the author to thoroughly read and criticize these letters. The young fellows meet once a week and the letters are read over and discussed by them before sending. No changes are made in the original, though a postscript may be written. It gives each an opportunity of knowing what the other is doing, how he expresses himself, etc.

You may wonder at these details and they may weary you, but they are essential to the subject. You can't go out in your shop and tell your superintendent to make you a foreman in the manner or with the ease he could make an engine bolt or grease cup. You can't pick a horse from the street, send him out to the track and expect him to lead the 2:10 trotters because you have put your bet on him. You would be considered a fool for so doing. If you are going into the racing business you select a horse whose sire has a pure strain of trotting blood for generations back. You go further; you put the colt in the hands of an experienced trainer, who for days and months and years gives him the food which experts have decreed is the right kind, give him the kind of exercise that will best develop enduring wind and fleetness of foot. But you cannot do all this in a day. So we have felt that the material we wish to develop for positions of responsibility must be selected early and trained for five years.

#### COLLEGE SCHOLARSHIPS

Four years ago I was advised that a Ryerson Master Mechanic scholarship vacancy existed, and the appointment would be made in a few months. We looked over the list of available boys and told two to try for it. One of these won. Last year another was awarded, upon a competitive examination, to a Santa Fe apprentice. We simply told a boy to go after it. This year we had several ready and waiting for the competitive examination and a Santa Fe boy walked away with the prize. We have more getting ready for the next one and will win that one too, so long as a competitive examination rules the selection. This is a by-



plants, and other plants. Is not this the more reason why railroads having such competition should do even more than product of our apprenticeship. It is the result of knowing our boys.

The law is laid down to us that we must not go outside for a mechanical officer. We must promote those who are now in service. The prize is hanging out to them and only when they fail us will we let outsiders enter the race. With this practice in vogue it would be very short-sighted to wait until the job was open to find a man. We believe in having the man ready for the job. We can't have a man ready at a moment's notice unless we are prudent enough to go into the matter a sufficient time ahead.

#### KNOW YOUR MEN

The weakness, or fitness, of a boy is not left to the judgment of one man. It is the result of four years of individual instruction. There is no such thing in our regular scheme as classes. There is no huddling together boys of all kinds, of all the various dispositions, capacity, and intelligence, each boy from the moment he makes application until the day we graduate him into manhood as a mechanic, is a class unto himself, is treated as a unit, and all the instruction we give him in shop and school room is individual. We go further. We have a governing body known as the apprentice board, composed of our general foreman, department foremen, gang foremen, shop and school instructors, who meet as a trial court to pass on each boy eight times during his apprenticeship. This board is as fair and honest and equally as anxious to mete out real justice as any court or body of men that ever assembled to pass judgment on a fellow man. Religion, politics, poverty, or pull never sway them one iota. If the boy is fit they pass him. If he is a misfit he goes, and no power can save him. Like our courts he may get a new trial. His case may be deferred, but justice will find him. That board is even more anxious in removing the ill-fitted and talentless boy than it is to encourage and help the genius. It is deemed a crime against the railroad, a crime against society, a crime against the boy's young life to require him to stay and attempt to learn a trade when all his talent and all his ambition lies in other channels. When a boy completes his apprenticeship we know him and his capabilities. He may not be a leader, he may not be a world beater, but we know what he *can* do and where to use him.

We have in our apprentice regulations of 22 articles, only two don'ts for the boy. We say he must not smoke cigarettes as the tendency of this practice is towards dishonesty. We say he must not drink for who wants a booze fighter? The other 20 articles are there to safeguard the boy.

When we graduate an apprentice we continue a watchful supervision over him. If he remains at his graduating shop the local instructors keep an eye on him, helping and advising him when necessary. If we transfer him to a distant shop his "follow-up" card is sent ahead to the instructor, who aids him in getting located and in securing a good boarding place, etc., making his first hour in the new town a pleasant one. In fact, the first person a graduate calls to see when entering any of our shops, is the apprentice instructor. He will be assured of one person at that place who will be interested in him. If he leaves the road, we still follow him. It may cost us a few postage stamps but the information is worth the stamps. So we have pretty nearly a perfect record of all our graduates. The location of 150 who have left us is as follows: On adjacent or connecting roads, 57; on distant roads, 14; in Canada, 4; "Somewhere in France," 2; in Panama assisting in operating the canal, 2; in garages, 37; in contract shops, 14; in business for themselves, 12; in the navy, 8.

The first position after leaving the ranks is the most trying of the young man's life. It is here he needs counsel and advice from old heads. We are prone, when entering on a new job, to try to do too much, to turn too many things upside

down, to make a record the first month. Right here is where the young man is liable to fail, and a steady, guiding hand is needed to balance him. A master mechanic who had promoted a young fellow to a roundhouse foremanship at an important terminal, told me that for one solid week he spent eight of the ten hours per day in that house. That week made one of the best roundhouse foremen on the system.

An incident recently occurred at Topeka which illustrates the point I am trying to drive home, i. e., knowing your men. The writer makes a monthly report showing number and location of all apprentices, etc. In this report for August was the name of one young boiler maker leaving the service, and the cause of his leaving. Our chief mechanical officer was much perturbed, and called in the superintendent of shops, boiler foreman and his assistant, two boiler shop instructors and the supervisor of apprentices for a conference over this young graduate apprentice leaving the service. I only mention this to emphasize that when such officers can and do spend one-fourth of an entire working day finding out why one young boiler maker had quit, you will find an organization which knows its men and is building for the future.

#### WHAT APPRENTICESHIP HAS ACCOMPLISHED

We are expecting good results from our apprentice graduates who have won the Ryerson scholarships. These young men had about completed their apprenticeship, are thoroughly equipped in practical shop and machine operations and are thoroughly familiar with the locomotive. They are now at first-class engineering schools. Their technical knowledge will mean something to them.

Our scheme is not complicated, on the contrary it is simple. It has not involved any revolution of our shop management. It has, however, demanded the individual effort of the writer, the co-operation of our mechanical officers, and the moral and official backing of all our executives from the president down. Has the game been worth the candle? Let me briefly recount the benefits we have enjoyed. From our apprentice system we have graduated over 900 first-class, skilled mechanics into our shop forces, trained and educated for Santa Fe work in Santa Fe ways, who in skillfulness, in general intelligence, in resourcefulness, in loyalty, are the superior of any equal body in similar vocations from any railroad or corporation of any place or any time. The present apprenticeship system has improved the whole moral tone of our shops. It has been the means of abolishing rawhiding and mule-driving. The use of profanity by officers to men has practically ceased, and the violation of Rule G is rare.

Of the graduates 72 per cent. are in service today. When you think of the fact that the average turnover of men in the shops and manufacturing plants in the country is three and one-half years, this is a flattering showing. Of the 72 per cent who have remained with us, over 100, or 15 per cent, have been promoted to some position of responsibility and we have others ready and waiting. The past year has been one of unusual activity, the biggest year in our history: more trains moving, more cars loaded, more engines turned than any previous year; yet we have not employed a mechanic from the outside for more than 12 months, and at our principal shops, Topeka, Kansas, no skilled mechanic has been employed for over two years. These are the fruits of our recruiting and training system. Can you beat it?

#### DISCUSSION

G. M. BASFORD (President, Locomotive Feedwater Heater Company): Several reasons are sure to be advanced to show why the Santa Fe plan will not work elsewhere. Some people think that it will not be satisfactory in a small organization. It is satisfactory in small organizations. Some will say that the labor union limitations on apprenticeship will not permit of such a plan. Is this a reason for not providing for such numbers as the unions do permit? Others will say that the Santa Fe does not have competition with ammunition

the Santa Fe has done to hold their boys? There can be no excuse, no justification, for failure to train men for the future. God help you and your successors if you do not do as the Santa Fe has done. How can you sleep nights until you have started this work? How can you feel sure of your own position until you have done this?

Everything the railroad uses is bought on specifications. It is considered necessary in order to secure what is wanted and what is paid for. But who selects the men? Where do they come from and of what quality are they? Construction work is controlled by specifications, but who constructs your personnel and how is it done? Clerks do the best they can in selecting raw recruits, but is it safe to place this great responsibility upon a clerk? Is it wise to allow him to accept or reject the man who may one day be your president?

Lacking constructive methods of picking recruits, training them and promoting them, it is no wonder that railroad presidents have told me that they did not know where to turn to find the men they need.

In nine years the Santa Fe has laid a grand foundation for the future, but the structure itself is only beginning. In time this great plan will be extended. It will not be complete until it embraces all departments. When this is done we shall not have difficulty in pointing to a truly great, efficient and perfectly balanced organization. Thorough training of well selected recruits is not all the Santa Fe does. It is fruitless to train men unless the organization is prepared to receive the product of the training. The promotion is as carefully handled as is the training. If it had not been, the graduates would scatter promptly. The boys will not quit if they can be shown that they cannot afford to quit.

Note the record of Santa Fe boys in winning the scholarship so generously provided for 14 years by the firm of Joseph T. Ryerson & Son. They have won it three times out of five. The best college men for railroads will be those from the ranks who win scholarships. This suggests the solution, and I believe the only solution, of the problem of college men on railroads. I hope the day will soon come when both large and small railroads will offer scholarships as prizes for their apprentices—in all departments. But some railroad organizations will change their methods of promotion if they are to hold such men afterward.

The speaker omitted to state that the Santa Fe success is due to the inspired individuals who started it and who had lived with it, as John Purcell, J. W. Kendrick, W. B. Storey and F. W. Thomas have done. Its foundation was laid many years ago when John Purcell formed his apprentices at the Fort Madison shops into a class of which he was the instructor. The class met nights and the instructor personally supplied accommodations, books and drawing materials. The larger work followed a single interview with the operating vice-president, J. W. Kendrick, who found ready support from President Ripley. It acquired fresh impetus and continued able support from Mr. Storey. Mr. Thomas did the work and he did and is doing it nobly, with Mr. Purcell as leader and counsellor and personal director. Inspiration at the top of the organization is the starting point. Many failures occur for lack of this essential. When the man higher up pounds the table and says, "I must have trained men. I'll discharge any officer who will not at once begin to train his own successor"—then you are ready to begin. The next step is to find an F. W. Thomas.

The new apprenticeship has proved itself. This, however, is only the beginning. Its field is every department and every office in the organization. When this truth is known railroads will come into their own. They will have better men and will keep their best ones, and what is more, employers and employees will better understand each other.

You are not advising your own son or the son of your best friend to enter the mechanical department of a railroad for a career. Think deeply of this. It is my opinion that

Mr. Thomas has the solution of the question—"What is the matter with the mechanical department?"

C. W. Cross (vice-president Equipment Improvement Company): The educating and training of young men in all departments of railway service is so tremendously important that it demands the best thought and effort of those in charge of the administration of our railroads. The Santa Fe plan, both as a whole and in its details, is excellent, but may have to be modified in some respects to meet local conditions. As is evidenced from Mr. Thomas' paper, the providing of a successful plan for apprenticeship is only a part of the task. The greatest measure of real profit to the railroad will be realized only when conditions are such as to attract and hold the graduate apprentice in service. It will be contended that the railroads cannot afford to meet the competition for skilled mechanics on the part of industries in manufacturing districts. Obviously the railroads must have a good supply of skilled mechanics if they are to operate efficiently and economically. It will be necessary to pay the graduate apprentices on the same basis as journeymen. Not only this, but the more deserving and ambitious ones must realize that they will be advanced to subordinate administrative positions if they make good. While the average boy has been accused of giving too much weight to immediate financial returns, such a statement is open to very serious question. In all probability, if conditions are made favorable and there is a spirit of enthusiasm in the organization and possibility for advancement, he will realize its importance and take it into consideration when more attractive financial inducements are offered him elsewhere.

The best results can only be obtained when such conditions confront the graduate apprentice and when the entire plan of apprenticeship is handled in a dignified, businesslike manner, with no appearance of paternalism, and with a thorough understanding that the company expects and demands expert service from those training for the work, for which it is willing to pay liberally.

Jacob H. Yoder, supervisor of apprentices, Pennsylvania Railroad, briefly outlined the Pennsylvania system of apprenticeship and emphasized the fact that it is designed primarily to provide an adequate supply of mechanics for the shop, rather than recruits for promotion. The apprentices are divided into three classes: regular, first class and special. The first class is made up of the exceptional regular apprentices, who are selected for broader training, including car work, locomotive firing, etc., these men being available for promotion to minor positions of responsibility. Members of this class are furloughed to attend college if they so desire and may return to the road as special apprentices. Special apprentices are college graduates.

E. R. Larsen, supervisor of apprentices, D. L. & W., spoke of the necessity of education in the broad sense, the methods of acquiring it, whether in college, through a correspondence school or through one's own personal efforts not being of prime importance. He stated it as his belief that the best results from college trained men may be obtained if they serve a regular apprenticeship course first and receive their college education afterwards.

In closing the discussion, Mr. Thomas stated that the entrance requirements for the regular apprenticeship course on the Santa Fe are very flexible, an applicant who has had the advantages of a high school education being examined much more rigidly than one who has not been beyond the grammar schools, the purpose being principally to discover how he has availed himself of his opportunities. He also emphasized the importance of providing ample shop instruction. This cannot be left to the foremen, who are usually too busy with other duties directly bearing on the output of the shop to give much attention to the work of the apprentices. Shop instructors are therefore necessary.

# New Devices

## PUNCH PRESS FOR MAKING WASHERS

In the illustration is shown a punch press which has recently been designed by the Southwark Foundry & Machine Company, Philadelphia, Pa., especially for the manufacture of washers from scrap plate. The machine may also be used for various forms of stamping, punching, shearing, etc. Its most useful field, however, is in the utilization of waste material by the manufacture of washers, the special die construction providing for the completion of a washer at each stroke of the ram. In this way, the concentricity of the hole with the outer circumference is insured.

The frame is one solid casting of the open gap type on which is mounted the gearing, plunger, cam shaft, dies, etc. The plunger has broad wearing surfaces and is equipped

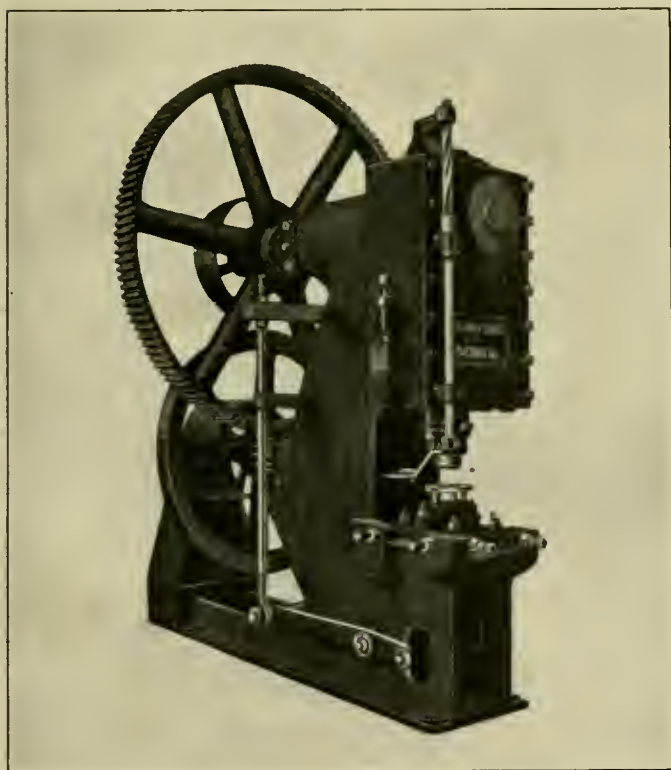

Punch Press Designed Especially for Making Washers from Scrap

with a bronze taper gib to take up wear. At its bottom are fastened the die and piercer, the former for cutting the outside of the washer and the latter for punching simultaneously the center hole. The punch is on the bottom and is held in a substantial punch holder block on the lower jaw of the frame. Surrounding this punch is the stripper ring, which, through connecting rods and lever, is operated from a cam on the back of the main shaft. In an annular space between the piercer and the die are a series of knockout pins for knocking down the washer, which sticks in the upper part of the die mechanism and goes up with the upward stroke of the plunger. These pins are operated by a bar passing cross-wise through the ram and at the top of

the stroke stopping against a pair of set screws in lugs cast on the frame.

At the left side of the machine is a vertical shaft which is splined at the top with a steep pitch thread. This passes through a nut which is fast to the top of the plunger, the up-and-down stroke of the ram imparting a rotary motion to the shaft. On the bottom of this shaft is the hand or cup which receives the knocked-out washer and throws it into a pile or suitable receptacle.

In addition to the flywheel shaft, the back of the main shaft is also equipped with a tight pulley, which permits the machine to be driven direct, without the intervention of the gear reduction when handling light work. The speed of production is thus limited only by the skill of the operator handling the material.

The machine is made in five sizes, the capacities of which range from 1/2-in. to 3-in. bolt size, and when provided with direct motor drive, power requirements range from a 5-hp. to a 15-hp. motor. Where desired, the presses may be equipped with a roller feed mechanism for automatically feeding washer stock in bands or bars.

## SPRING NUT LOCK

A simple spring nut lock, which is designed to replace the ordinary type of jam nut, has recently been brought out by the Industrial Development Corporation, Chicago. The device consists of two octagonal plates of thin steel, which are stamped from the sheet in one piece, a connection being pro-

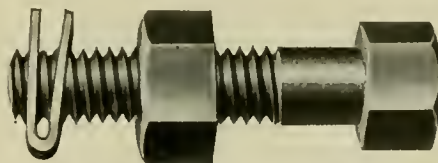

The Loose Nut Lock Applied to the Bolt

vided between adjoining sides of the octagons. The plates are first stamped from the sheet, after which a circular hole is punched in each octagon of a size to fit the bolt for which it is intended. The plate is then bent until the two holes are almost in line, one being slightly offset from the other.

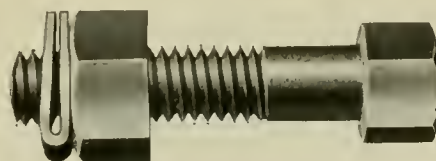

Tightened Against the Nut, the Nut Lock Follows the Nut as It Is Set Up Against the Material

The connection between the two plates acts as a hinge and, after being tempered, provide a powerful spring action.

When the nut lock is slipped on the bolt and both legs engage the thread of the screw, the holes in the two parts are forced into perfect alignment against the action of the

spring connection, which exerts a powerful pulling force on one of the legs and a similar pushing force on the other. The leg on which the pulling force is exerted thus engages the valley of the thread on the side of the bolt opposite the spring, while the leg on which the pushing force is exerted, engages the valley of the thread on the side of the bolt adjacent to the spring. Tightened into place against the nut, the gripping on the threads thus produced is said to resist the action of vibration which tends to slack off the nut.

**LOCOMOTIVE POWER REVERSE GEAR**

An ingenious power reverse gear for use on locomotives has been invented by M. F. Cox, assistant superintendent of machinery, Louisville & Nashville, and is in use on the eight-wheel switching engines recently built by that road. This gear consists of a vertical shaft the lower end of which contains an integral worm that meshes with a bronze worm

handle will be moved left to right for the forward movement of the engine, and the opposite direction for the backward movement. The wheel shown at the top of the vertical shaft is only used when it is desired to reverse by hand. It is readily removed and may be stowed away when the gear is being operated by power. The upper portion of the vertical shaft is threaded and fitted with an indicator nut which shows the engineer at a glance, the length of cut-off at which the engine is running. The scale for this indicator or pointer is located in full view on the outside of the reverse gear housing. This feature, of course, is of greater importance on road engines as switchers seldom, if ever, operate except in the corners. It requires 14 revolutions of the vertical shaft to bring the engine from full gear forward to full gear backward. With the air motor and 45 to 50 lb. air pressure, this can be accomplished in a few seconds. Its operation is smooth and noiseless. Its advantages are recognized over the old method often requiring 100 to 150 re-

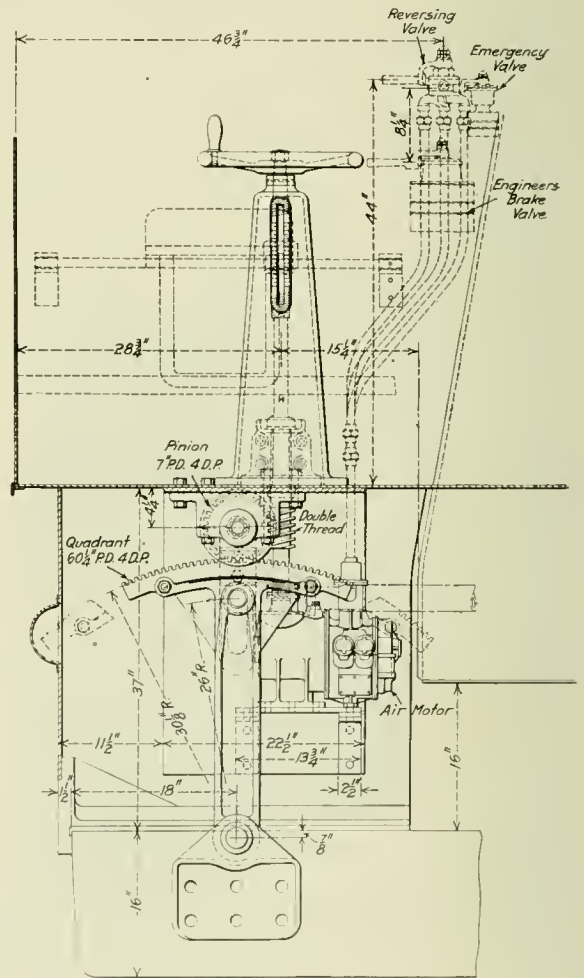
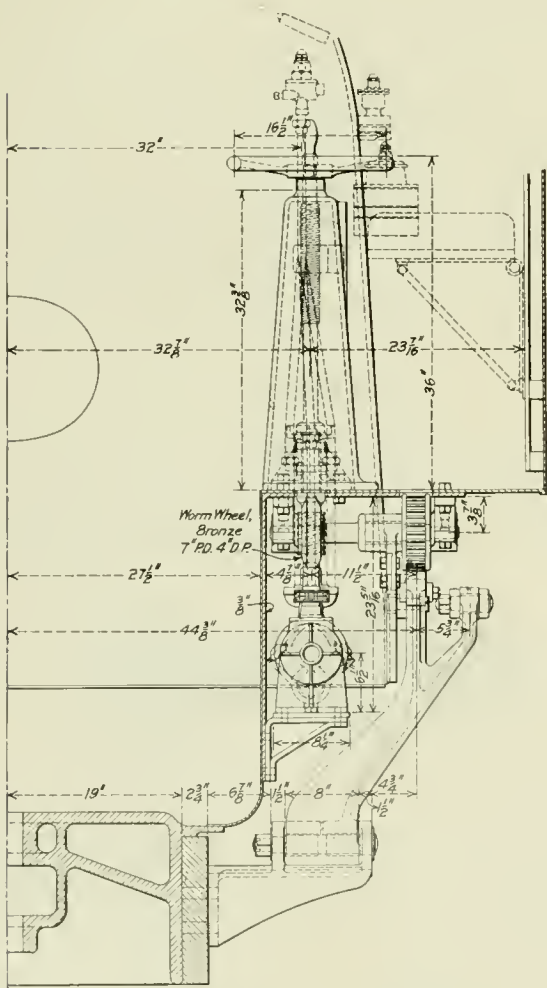

Power Reverse Gear Developed on the Louisville & Nashville

wheel located on a short horizontal shaft. On the opposite end of the horizontal shaft is a shrouded steel pinion meshing with a segment of a steel gear. This segment and the reach rod connection form one forked steel casting fulcrumed at the bottom to a substantial bracket and steel pin. This device may be operated either by hand or other power. The illustration shows the gear arranged for operation by an air motor the main spindle of which is connected at the base of the vertical worm shaft above mentioned by means of a flexible coupling. The motor is controlled and operated by a two-way valve conveniently attached to the boiler head within easy reach of the engineer and so arranged that the

versals during the course of a day, and the attention of the engineer diverted from the tracks, while struggling to reverse a heavy, stiff gear. Patent for this gear is now pending.

**EFFECT OF ROLLING ON STRENGTH OF BRASS.**—The tensile strength of test pieces taken from steel and iron sheets in the direction of rolling is greater than that of test pieces taken at right angles to the direction of rolling. In general, the reverse of this is true with test pieces taken from rolled brass. Further, the greater the reduction of the brass sheet by rolling the greater the comparative strength of the test piece taken across the grain.—*American Machinist.*

### CLEAR VISION CAB WINDOW

A clear vision cab window which meets the requirements of the new federal government ruling has been designed and a patent applied for by F. Hopper, master mechanic of the Duluth, Winnipeg & Pacific, Duluth, Minn. The drawing shows the details of the window's construction and its application to front cab windows.

It is necessary in applying this window to cut a hole in the cab window in the direct line of the engineman's vision. This hole is made the full width of the window and 5½ in. deep.

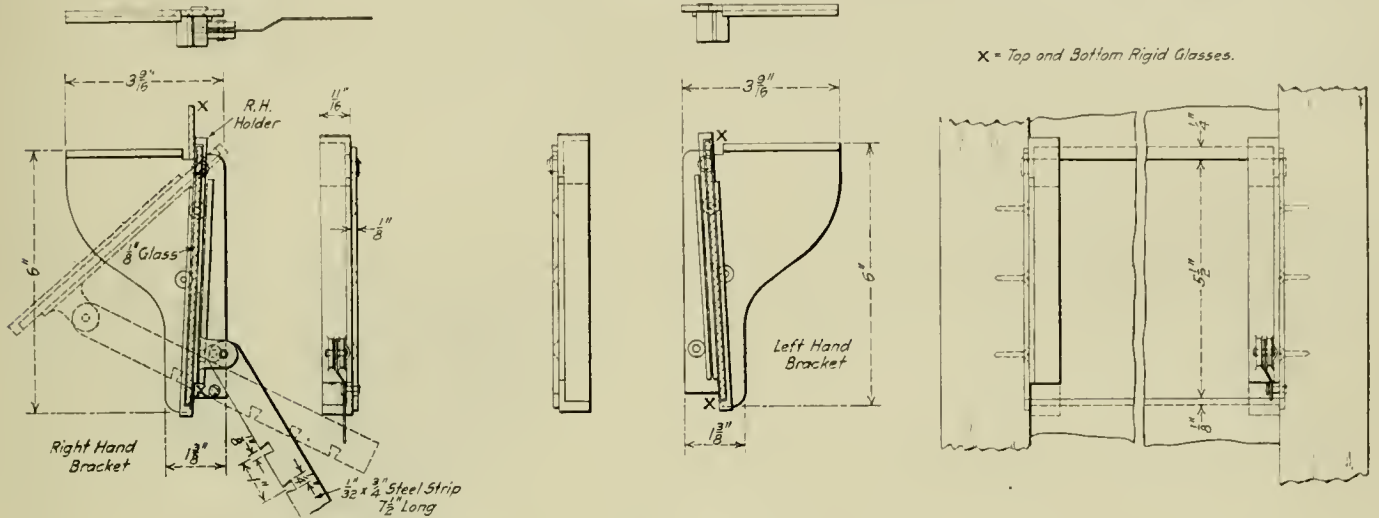

Details and Application of Clear Vision Window to Front Cab Windows

The brackets, which are applied to the side frames of the window, contain a piece of glass 5⅞ in. deep and of a width to suit the width of the cab window and the space taken by the brackets. The glass in the clear vision window overlaps that of the cab window at the top on the inside ¼ in. and at the bottom on the outside ⅛ in. An operating handle is provided to move the window into whatever position is desired and when it is closed direct air currents, rain and snow are excluded because of the overlap at the top and bottom. It is advisable to place tape on the ends of the glass before placing it in the holders. There are no cross pieces of wood or metal in the cab window to obstruct the view of the engineman; even with the clear vision window applied the complete area of the window glass remains. The window is inexpensive to make; there are only four small metal parts which may be made of brass, pressed steel or malleable iron. It is easily applied and the cost of application is small. Windows of this type are in service on the Duluth, Winnipeg and Pacific and the enginemen on that road express themselves as greatly pleased with them.

preparation was reduced from 4 per cent to 2.02 per cent. It is further claimed by the company that Soldco will make the leather to which it is applied impervious to moisture or chemical fumes.

### BOYER PEDESTAL RIVETER

A pedestal machine for riveting small, light parts, which can best be handled in a stationary machine, has been designed by the Chicago Pneumatic Tool Company, Chicago.

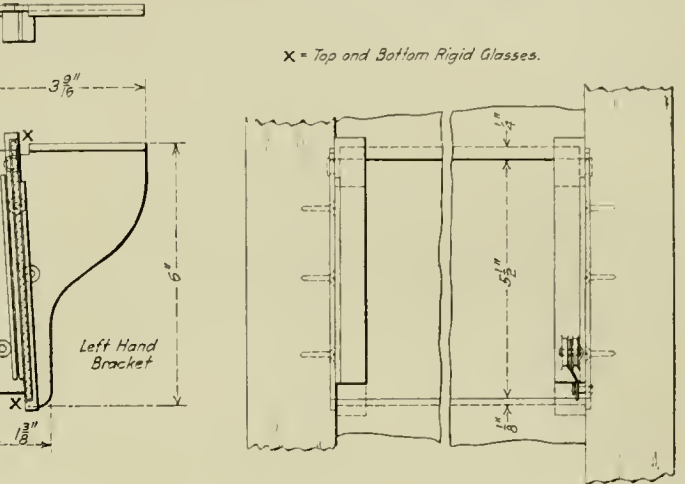

The machine is operated by a foot lever, leaving the operator's hands free to handle the work.

The yoke consists of a crucible steel frame mounted in

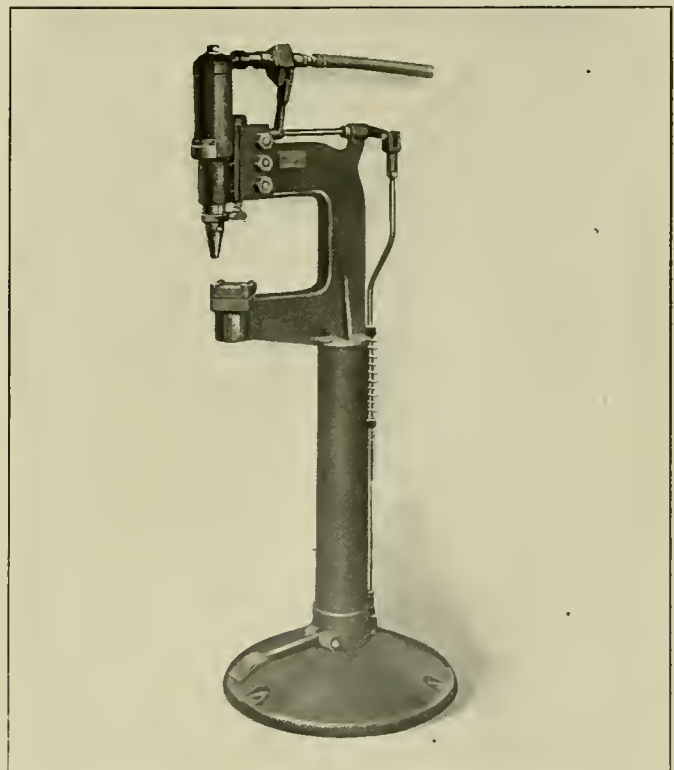

Foot-Operated Pedestal Riveter for Light Parts

the end of a pipe column, the whole being supported on a cast iron base and held together with a ¾-in. bolt. The base is provided with anchor bolt holes to permit securely

### PREPARATION FOR LEATHER BELTS

The Duntley Company, Chicago, has placed on the market a preparation called Soldco for leather belts, that is claimed to materially increase the life of the belt. The principal ingredient is a product that is used in the manufacture of Russian leather. Soldco is non-volatile, non-inflammable and non-combustible. It contains no acid and remains liquid under all atmospheric conditions. From tests made by the Griffin Wheel Company, of Chicago, it was found that this material does not contain rosin, mineral oil, acid or soap. It was found that it readily penetrates the leather, keeping it pliable, without producing an oily surface. It was also found that belts treated with Soldco would operate equally well in dusty or hot places as in cool and clean places. It was further found that the average slippage on belts treated with this

fastening it to the floor. The standard yoke has a gap of 8 in. and a reach of 11 in., but additional yokes may be had for any desired dimensions to accommodate larger work. Where it is desirable to handle more than one size rivet, a special dolly may be supplied that will accommodate four different sizes. This dolly is made to permit of its being used in very close corners and it can be replaced at reasonable cost when worn out.

The riveter head is a standard Boyer riveter, either 1 1/16-in. by 3-in., 1 1/16-in. by 4-in., or 1 1/16-in. by 5-in., and is held in a clamp which provides for adjusting it to take care of the wear on the dies as well as any variation in the length of the rivets. The net weight of the machine when equipped with the 1 1/16-in. by 3-in. riveter is approximately 173 lb.

### DUMORE PORTABLE GRINDER

The Wisconsin Electric Company, Racine, Wis., has placed on the market a portable grinder which may be used for a large variety of purposes in the machine shop and tool room. This grinder weighs 17 lb. and is designed to be used in lathes, milling machines, shapers, etc. It is operated direct from the lamp circuit, having a universal motor which permits it being used with alternating current as well as direct current.

It comes provided with seven grinding wheels, ranging from 3/8 in. to 4 1/2 in. in diameter. It is provided with two spindles, one of which is used for surface grinding and the other for internal grinding. The speed of the spindle for

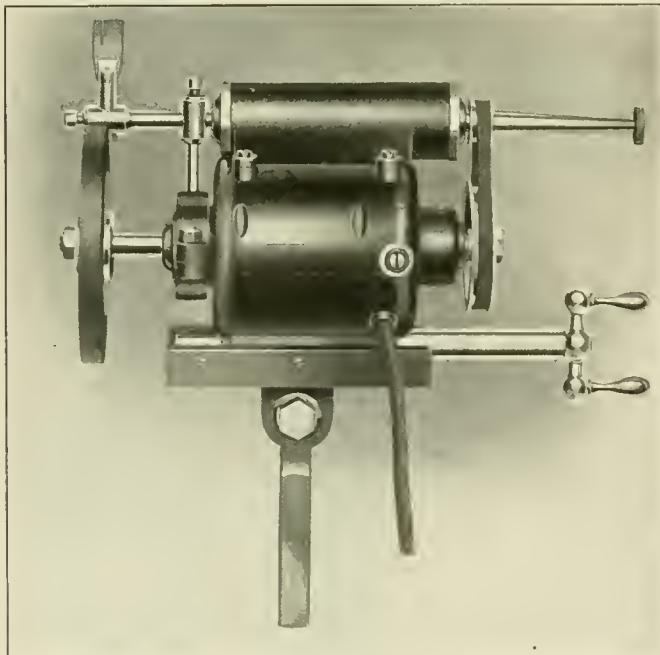

Portable Electric Grinder

the external grinding is 10,000 r.p.m., and that of the internal grinding spindle is 30,000 r.p.m. The armature, pulleys and grinding wheels are dynamically balanced, thereby eliminating any vibration in the motor, and leaving the ground surface free from chatter marks. This grinder can be used for grinding lathe centers, milling cutters, longitudinal and cylindrical grinding, internal grinding, and is especially adapted for small work difficult to machine, yet where accurate surfaces are required. It is provided throughout with S.F.K. ball bearings and it is provided with a cross feed which moves the motor longitudinally with its grinding wheels.

### THREADING MACHINE FOR HOLLOW SET SCREWS

A threading machine has recently been placed on the market by the Landis Machine Company, Waynesboro, Pa., which is equipped with special carriages for threading hollow safety set screws. While primarily designed for this class of work, they may be employed in threading stock where there is a continuous thread and a similar method of holding.

The carriages proper are stationary and support two spindles which have a free, horizontal movement. These spindles are brought to the threading die heads by means of weights which are attached by chains to the levers operating the spindles. These weights exercise a constant force upon

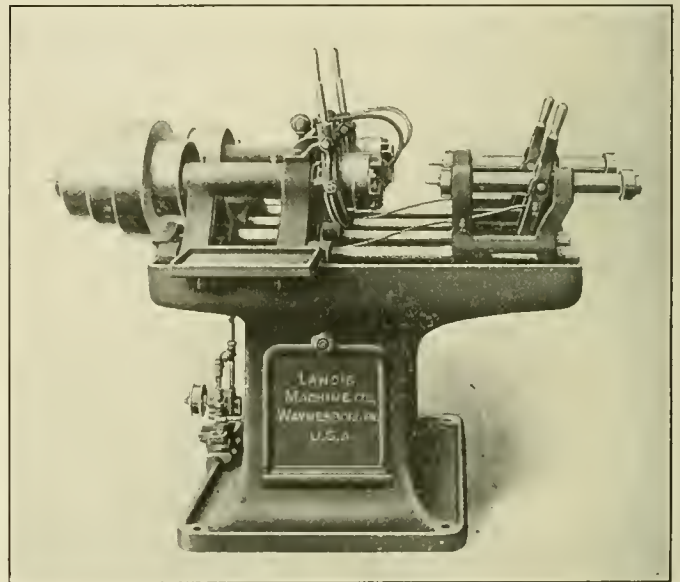

Landis Hollow Set Screw Threading Machine

the spindles in the direction of the die heads, making it unnecessary for the operator to advance the stock for the threading operation. The heads of the spindles are bored and fitted with mandrels for holding the set screws. A collar is placed on the rear of each spindle, making it adjustable for cutting any desired length of thread. For the threading operation the set screw is placed upon the mandrel and the spindle automatically forces it into the die head. When the screw is threaded, it remains in a tube which extends through the spindle from the face of the threading die head to the rear of the machine. The subsequent threading of screws forces the finished pieces through the tube, from which they drop into a receptacle placed at the rear of the machine.

These machines may also be used for threading standard bolts by attaching automatic opening and closing attachments for the die heads. When standard bolts are threaded, the heads of the spindles on the carriages are fitted with bolt sockets for the various diameters within the range of the machine. These machines are equipped with Landis all steel die heads which employ long-life chasers.

**INCREASE IN PRODUCTION OF STEEL PIPE.**—A special statistical bulletin has been issued by the American Iron and Steel Institute showing the production of iron and steel skelp in the United States from 1905 to 1915 inclusive. In 1905, of a total production of 1,435,995 gross tons, 452,797 tons were of iron and 938,198 tons of steel. In 1915 the total production was 2,299,464 gross tons, of which 262,198 tons were of iron and 2,037,266 tons of steel.

# Railway Mechanical Engineer

(Formerly the RAILWAY AGE GAZETTE, MECHANICAL EDITION  
with which the AMERICAN ENGINEER was incorporated)

PUBLISHED ON THE FIRST THURSDAY OF EVERY MONTH BY THE  
SIMMONS-BOARDMAN PUBLISHING COMPANY

EDWARD A. SIMMONS, *President* L. B. SHERMAN, *Vice-President*  
HENRY LEE, *Vice-President and Treasurer* M. H. WIUM, *Secretary*  
WOOLWORTH BUILDING, NEW YORK, N. Y.  
F. H. THOMPSON, *Business Manager*, CHICAGO.

Chicago: Transportation Bldg. Cleveland: Citizens' Bldg.  
Washington: Home Life Bldg.  
London: Queen Anne's Chambers, Westminster.

ROY V. WRIGHT, *Editor*  
A. C. LOUDON, *Managing Editor*  
R. E. TRAYER, *Associate Editor* C. B. PECK, *Associate Editor*

Entered at the Post Office at New York, N. Y., as mail matter of the  
second class.

Subscriptions, including the eight daily editions of the *Railway Age Gazette* published in June in connection with the annual conventions of the Master Car Builders' and American Railway Master Mechanics' Associations, payable in advance and postage free: United States, Canada and Mexico, \$2.00 a year; Foreign Countries (excepting daily editions), \$3.00 a year; Single Copy, 20 cents.

WE GUARANTEE that of this issue 8,700 copies were printed; that of these 8,700 copies, 7,532 were mailed to regular paid subscribers, 112 were provided for counter and news companies' sales, 548 were mailed to advertisers, exchanges and correspondents, and 508 were provided for new subscriptions, samples, copies lost in the mail and office use; that the total copies printed this year to date were 91,600, an average of 8,327 copies a month.

The RAILWAY MECHANICAL ENGINEER is a member of the Audit Bureau of Circulations.

VOLUME 90

NOVEMBER, 1916

NUMBER 11

## CONTENTS

### EDITORIALS:

Our Prize Competitions.....	549
Higher Officers, Attention!.....	549
The Value of the Shop Band.....	549
The Two Convention Stories.....	549
Loss and Damage to Freight.....	549
The Eight-Hour Day Question.....	550
Selection of Future Officers.....	550
Uniform Interpretation of Interchange Rules.....	550
Car Department Apprentice Problem.....	551
A Weak Spot in Shop Management.....	551
New Books .....	551

### GENERAL:

British Express Locomotives.....	552
Mechanical Design of Electric Locomotives.....	558
Traveling Engineers' Convention.....	561
Powdered Coal in Engine Service.....	565
Triangle for Use in Tracing.....	568

### CAR DEPARTMENT:

Thoughts Suggested by Indianapolis Convention.....	569
Work of the Association of Manufacturers of Chilled Car Wheels..	570
Preventing Hot Boxes on the New Haven.....	570
Car Inspectors' and Car Foremen's Convention.....	571
The Essential Requirements and Correct Treatment of Head-linings.	580
Fitting Up Car Journal Brasses .....	581
Clasp Brakes for Heavy Passenger Equipment Cars.....	581
Refrigerating Freight in Transit.....	585

### SHOP PRACTICE:

Plunger for Holding Bar Stock.....	589
Old Man Drilling Post.....	589
Increasing Shop Output.....	589
Fuel Oil Installation for Small Shops.....	590
Electric Welding in Railroad Shops.....	591
Cylinder Head Grinder.....	595
Enginehouse Practice .....	595
Eccentric Keyway Cutter.....	596
Combination Pneumatic Spring Shear and Bender.....	596
Training Young Men for Promotion.....	597

### NEW DEVICES:

Punch Press for Making Washers.....	601
Spring Nut Lock.....	601
Locomotive Power Reverse Gear.....	602
Clear Vision Cab Window.....	603
Preparation for Leather Belts.....	603
Boyer Pedestal Riveter.....	603
Dumore Portable Grinder.....	604
Threading Machine for Hollow Set Screws.....	604

### NEWS DEPARTMENT:

Notes .....	605
Meetings and Conventions.....	606
Personals .....	607
Supply Trade Notes.....	608
Catalogues .....	610

The department of safety of the St. Louis-San Francisco has extended the scope of its work by the appointment of two new safety inspectors, David Smith and W. F. Morrison. Mr. Smith will study shop conditions and Mr. Morrison train service.

#### MEMORIAL TABLET TO WILLIAM O'HERIN

On Saturday, October 7, a memorial tablet to William O'Herin, former superintendent of motive power of the Missouri, Kansas & Texas, was unveiled at Parsons, Kan., in the presence of thousands of employees. The tablet is placed between the passenger station and the general office building.

Mr. O'Herin was connected with the Missouri, Kansas & Texas for more than 41 years, joining that organization as an engineer and rising through various positions to superintendent of motive power. It was in this capacity, and while superintending the clearing of a wreck that he re-

ceived the injuries which resulted in his death some months later, in 1914. The veil covering the memorial was raised by the Misses Kathleen and Ellen O'Herin, nieces of Mr. O'Herin. Following the unveiling, John S. Leahy, a prominent attorney of St. Louis, delivered an address. W. E. Williams, general manager of the M., K. & T., north of the Red river, followed Mr. Leahy and spoke on the life and work of Mr. O'Herin. The memorial tablet cost about \$2,000 and was bought with funds raised among Mr. O'Herin's many warm admirers and friends in the ranks of the Missouri, Kansas & Texas Railway organization.

#### CARS AND LOCOMOTIVES ORDERED IN OCTOBER

The orders for cars and locomotives reported during the month of October made the month, despite the high prices for such equipment, one of the best thus far this year. Prices are so high, however, that there can be little doubt that such

purchases as are being made are only those that are absolutely necessary.

The totals of orders reported during the month were as follows:

	Locomotives	Freight cars	Passenger cars
Domestic .....	87	21,034	112
Foreign .....	181	.....	.....
Total .....	268	21,034	112

The important orders for locomotives included the following:

Road	No.	Type	Builder
Buffalo, Rochester & Pitts-burgh.....	10	Mikado	American
Chesapeake & Ohio.....	5	Mallet	American
Western Maryland.....	25	Mallet	American
Wheeling & Lake Erie.....	10	Mallet	Lima
British War Office.....	100	2-6-2 tank	American
Finland State Rys.....	20	Consolidation	American
Orleans Ry. (France).....	50	Mikado	American

The orders for freight cars included the following:

Company	No.	Type	Builder
Chesapeake & Ohio.....	1,000	Hopper	Std. Steel
	500	Hopper	Pressed Steel
	500	Hopper	Ralston
Chicago & North Western.....	500	Ore	Pullman
	1,000	Gondola	Pullman
	1,500	Box	Am. C. & F.
Louisville & Nashville.....	1,000	Gondola	Pressed Steel
	500	Hopper	Pressed Steel
	1,500	Gen. Ser.	Am. C. & F.
Missouri Pacific.....	2,000	Gondola	Am. C. & F.
	1,000	Box	Am. C. & F.
	2,000	Gondola	Std. Steel
Union Tank Line.....	500	Tank	Pressed Steel
	500	Tank	Std. Steel
	1,000	Tank	Am. C. & F.
	250	Tank	Co. shops
Western Maryland.....	2,000	Hopper	Pullman
Wheeling & Lake Erie.....	500	Gondola	Pressed Steel
	500	Gondola	Std. Steel

The passenger car orders included the following: Chesapeake & Ohio, 10 coaches, 1 dining and 2 parlor cars, American Car & Foundry Company; Great Northern, 15 postal cars, Pressed Steel Car Company; Louisville & Nashville, 6 coaches, 4 horse and baggage cars and 4 baggage and mail cars, American Car & Foundry Company, and Long Island, 15 coaches and 45 trailer cars, Pressed Steel Car Company.

MEETINGS AND CONVENTIONS

*Association of Manufacturers of Chilled Car Wheels.*—At the annual meeting of this association, in New York, on October 17, the following officers were elected: George W. Lyndon, president and treasurer; E. F. Carry, Haskell & Barker Car Company, vice-president; J. A. Kilpatrick, Albany Car Wheel Company, vice-president; Geo. F. Griffin, secretary, and F. K. Vial, Griffin Wheel Company, consulting engineer.

*Railroad Section, A. S. M. E.*—The meeting of the Railroad Section of the American Society of Mechanical Engineers, which will be held in New York City, Friday morning, December 8, promises to be a big success. Two of the papers which will be presented are printed elsewhere in this issue—one, by Thomas L. Burton, on Clasp Brakes and one, by A. F. Batchelder, on Mechanical Design of Electric Locomotives. A third paper on Pulverized Fuel for Locomotives will be presented by J. E. Muhlfeld. A large num-

ber have already signified their intention of attending the meeting and discussing the papers.

*Smoke Prevention Association.*—At the eleventh annual convention of the Smoke Prevention Association, which was held at the Planters Hotel, St. Louis, September 26 to 29, the following officers were elected for the ensuing year: President, W. H. Reed, chief smoke inspector, City of Chicago; first vice-president, Marten Rooney, chief smoke inspector, City of Nashville, Nashville, Tenn.; second vice-president, W. L. Robinson, supervisor fuel consumption, Baltimore & Ohio; secretary-treasurer, A. A. Chambers, of the Smoke Inspection Bureau, City of Chicago. Columbus, Ohio, was chosen as the next convention city.

*Car Foremen's Association of Chicago.*—The Car Foremen's Association of Chicago held its annual meeting at the Hotel La Salle, Chicago, October 10, at which an entertainment program was provided for the members and their guests. During the past year the association has had an average attendance of 169 members. During the year 921 new members were enrolled in the organization, making a total membership of 2,535, which makes this association the largest body of car men in the country. The following officers were elected for the ensuing year: President, A. L. Beardsley, division master mechanic of the Atchison, Topeka & Santa Fe, Chicago; first vice-president, H. H. Estep, general foreman of the car department, Chicago & Eastern Illinois; second vice-president, E. G. Chenoweth, mechanical engineer for the car department, Chicago, Rock Island & Pacific; treasurer, M. F. Covert, assistant master car builder, Swift Car Lines, and secretary, Aaron Kline, 841 Lawler avenue, Chicago.

- The following list gives names of secretaries, dates of next or regular meetings and places of meeting of mechanical associations:
- AIR BRAKE ASSOCIATION.—F. M. Nellis, Room 3014, 165 Broadway, New York City.
  - AMERICAN RAILROAD MASTER TINNERS', COPPERSMITHS' AND PIPEFITTERS' ASSOCIATION.—O. E. Schlink, 485 W. Fifth St., Peru, Ind.
  - AMERICAN RAILWAY MASTER MECHANICS' ASSOCIATION.—J. W. Taylor, Karpen Building, Chicago.
  - AMERICAN RAILWAY TOOL FOREMEN'S ASSOCIATION.—Owen D. Kinsey, Illinois, Central, Chicago.
  - AMERICAN SOCIETY FOR TESTING MATERIALS.—Prof. E. Marburg, University of Pennsylvania, Philadelphia, Pa.
  - AMERICAN SOCIETY OF MECHANICAL ENGINEERS.—Calvin W. Rice, 29 W. Thirty-ninth St., New York. Annual Meeting, December 5-8, 1916, New York.
  - ASSOCIATION OF RAILWAY ELECTRICAL ENGINEERS.—Joseph A. Andreuccetti, C. & N. W., Room 411, C. & N. W. Station, Chicago.
  - CAR FOREMEN'S ASSOCIATION OF CHICAGO.—Aaron Kline, 841 Lawler Ave., Chicago. Second Monday in month, except June, July and August, Hotel La Salle, Chicago.
  - CHIEF INTERCHANGE CAR INSPECTORS' AND CAR FOREMEN'S ASSOCIATION.—W. R. McMunn, New York Central, Albany, N. Y.
  - INTERNATIONAL RAILROAD MASTER BLACKSMITHS' ASSOCIATION.—A. L. Woodworth, C. H. & D., Lima, Ohio.
  - INTERNATIONAL RAILWAY FUEL ASSOCIATION.—J. G. Crawford, 547 W. Jackson Blvd., Chicago. Convention, May, 1917, Chicago.
  - INTERNATIONAL RAILWAY GENERAL FOREMEN'S ASSOCIATION.—William Hall, 1126 W. Broadway, Winona, Minn.
  - MASTER BOILERMAKERS' ASSOCIATION.—Harry D. Vought, 95 Liberty St., New York.
  - MASTER CAR BUILDERS' ASSOCIATION.—J. W. Taylor, Karpen Building, Chicago.
  - MASTER CAR AND LOCOMOTIVE PAINTERS' ASSOCIATION OF U. S. AND CANADA.—A. P. Dahe, B. & M., Reading, Mass.
  - NIAGARA FRONTIER CAR MEN'S ASSOCIATION.—E. N. Frankenberger, 623 Brisbane Building, Buffalo, N. Y. Meetings, third Wednesday in month, New York Telephone Bldg., Buffalo, N. Y.
  - RAILWAY STOREKEEPERS' ASSOCIATION.—J. P. Murphy, Box C, Collinwood, Ohio.
  - TRAVELING ENGINEERS' ASSOCIATION.—W. O. Thompson, N. Y. C. R. R., Cleveland, Ohio. Convention was to have been held September 5-8, 1917, Hotel Sherman, Chicago. Postponed.

RAILROAD CLUB MEETINGS

Club	Next Meeting	Title of Paper	Author	Secretary	Address
Canadian.....	Nov. 14	Pulverized Fuel for Locomotives.....	J. S. Coffin, Jr....	James Powell.....	P. O. Box 7, St. Lambert, Que.
Central.....	Nov. 17	Locomotive Fuel Economy and Drafting of Locomotives.....	D. R. McBain....	Harry D. Vought..	95 Liberty St., New York.
Cincinnati.....	Nov. 14	Annual Meeting, and Banquet.....	Howard Elliott..	H. Boutet.....	101 Carew Bldg., Cincinnati, Ohio.
New England.....	Nov. 16	Address.....	L. O. Armstrong..	Wm. Cade, Jr....	683 Atlantic Ave., Boston, Mass.
New York.....	Nov. 17	Water Powers of Canada—Moving Pictures.....	.....	Harry D. Vought..	95 Liberty St., New York.
Pittsburgh.....	Nov. 13	Annual Meeting; Election of Officers.....	.....	J. B. Anderson....	207 Penn Station, Pitts-burgh, Pa.
Richmond.....	Nov. 10	Mechanical Stokers for Locomotives.....	W. S. Bartholomew	F. O. Robinson....	C. & O. Railway, Richmond, Va.
St. Louis.....	Nov. 16	Fire Prevention; Election of Officers.....	.....	B. W. Franenthal..	Union Station, St. Louis, Mo.
South'n & S'w'n.....	Nov. 20	.....	.....	A. J. Merrill.....	Box 1205, Atlanta, Ga.
Western.....	Nov. 20	.....	.....	Jos. W. Taylor....	1112 Karpen Bldg., Chicago.



## PERSONAL

### GENERAL

**WILLIAM KELLY**, general master mechanic of the Great Northern at Spokane, Wash., has been appointed assistant superintendent of motive power, with headquarters at Spokane, and jurisdiction over the Central and Western districts.

### MASTER MECHANICS AND ROAD FOREMEN OF ENGINES

**BERTRON H. DAVIS**, who has been appointed assistant master mechanic of the Delaware, Lackawanna & Western at Scranton, Pa., was born in Ithaca, N. Y., October 9, 1873. After receiving a common school education he entered railroad service in March, 1890, as a machinist helper in the locomotive shops of the Delaware, Lackawanna & Western at Scranton. In May, 1893, he became a locomotive fireman and was promoted to engineman in November, 1901. He ran an engine until September, 1911, when he was appointed assistant road foreman of engines, about a year later becoming road foreman of engines. He continued to serve in this capacity until his recent appointment.

**N. C. BETTENBURG**, who has been appointed master mechanic of the Great Northern at Minot, N. Dak., was born in St. Cloud, Minn., January 14, 1872. He received his education in the district school and began his railroad career in December, 1890, with the St. Paul & Duluth. In December, 1895, he entered the service of the Great Northern as a machinist at St. Paul, Minn. He remained here until 1901, when he was appointed general foreman, serving in this capacity at Barnesville, Melrose and St. Paul. He was subsequently appointed master mechanic and traveling master mechanic, being transferred to the Minot



N. C. Bettenburg

division on October 1, as above noted, when the latter office was discontinued.

**J. J. DOWLING** has been appointed master mechanic of the Great Northern, with headquarters at Delta, Wash.

**B. J. FARR** has been appointed master mechanic of the Grand Trunk, western lines, with headquarters at Battle Creek, Mich., in place of W. H. Sample, transferred.

**F. M. FRYBURG** has been appointed master mechanic of the Great Northern, at Great Falls, Mont.

**A. H. KENDALL** has been appointed master mechanic of the Canadian Pacific at Toronto, Ont., succeeding W. J. Pickrell, transferred.

**T. J. RAYCROFT**, assistant master mechanic of the Cumberland division of the Baltimore & Ohio, has been appointed master mechanic of the Wheeling division, with headquarters at Wheeling, W. Va., succeeding James Bleasdale, resigned, to accept service elsewhere.

**FRANK H. REAGAN**, superintendent of shops of the Delaware, Lackawanna & Western at Scranton, Pa., has been appointed master mechanic of the Scranton, the Syracuse & Utica and the Bangor & Portland divisions, succeeding George Durham, resigned to go to another company.

**WILLIAM R. ELMORE**, recently appointed master mechanic of the Nevada Northern, with headquarters at East Ely, Nev., was born at Greers, S. C., on October 14, 1867. He



W. R. Elmore

first entered railway service with the Nashville, Chattanooga & St. Louis in March, 1895, as an air brake machinist in the locomotive and car department. He remained with this company until 1903, following which he served as machinist with the Southern at Atlanta, Ga., and Birmingham, Ala., with the Louisville & Nashville at Birmingham, with a steel works at Pueblo, Colo., and with the Denver & Rio Grande at Alamosa, Colo. He was here made erecting shop foreman in November, 1910, three years later being transferred to the Utah lines as general foreman at Salt Lake City. He remained here until March 1, 1915, when he entered the service of the Nevada Northern as general foreman.

### PURCHASING AND STOREKEEPING

**HARRY P. SPANN** has been appointed division storekeeper of the Atchison, Topeka & Santa Fe, at River Bank, Cal., succeeding G. O. Hixon, who has been transferred.

### OBITUARY

**THEODORE N. ELY**, formerly chief of motive power of the Pennsylvania Railroad System, including the lines both east and west of Pittsburgh and Erie, who retired from railway work on July 1, 1911, after 43 years of service, died on October 28, at his home in Bryn Mawr, Pa., aged 70.

**WILLIAM McWOOD**, formerly superintendent of the car department of the Grand Trunk, from which position he retired on a pension in 1908, died on October 4, after a long illness. He was born in 1830 at Montreal, Quebec, and served an apprenticeship with John Thornton, coach builder. He entered the services of the Grand Trunk in 1855, and from 1860 to 1873 was foreman on the same road. He then served as assistant mechanical superintendent and superintendent of the car department of the same road, in charge of the car department of the entire line from 1873 until his retirement on January 1, 1908, after a continuous service of 53 years with the Grand Trunk. Mr. McWood took a very active part in the organization of the Master Car Builders' Association, having been a member of that association since 1875. From 1882 to 1887 he served as vice-president, and for the three years 1888, 1889 and 1890 as president.



W. McWood

## SUPPLY TRADE NOTES

The Greenfield Tap & Die Corporation, Greenfield, Mass., has discontinued its store in Detroit, Mich.

D. P. Lameroux has been appointed general manager of the Pratt & Letchworth Company, Ltd., Brantford, Ont.

G. L. Simonds & Co., Chicago, have changed their name to the Vulcan Fuel Economy Company. The personnel and policies of the organization remain the same.

Stanley H. Smith, of the sales staff of the Bethlehem Steel Company, at Chicago, Ill., has been appointed sales agent of the Cleveland district, with office at Cleveland, Ohio.

The H. W. Johns-Manville Company, New York, announces that Harry Flanagan, formerly with the Grip Nut Company, will represent its railroad department in the Twin City territory.

The U. S. Light & Heat Corporation, Niagara Falls, N. Y., at a recent meeting of its board of directors, elected C. L. Lane vice-president. Mr. Lane was formerly secretary of the company.

John Hulst, chief engineer of the Carnegie Steel Company, has been appointed assistant to vice-president and chief engineer of the United States Steel Corporation, succeeding Marvin A. Neeland.

The R. & J. Dick Company, Inc., Passaic, N. J., opened a branch office at Atlanta, Ga., on October 1. This is the second new branch established during the year, the other being an office in Seattle, Wash., which was opened in January.

Marvin A. Neeland, assistant to vice-president and chief engineer of the United States Steel Corporation, has resigned to accept the position of consulting engineer of the American International Corporation, with headquarters at 120 Broadway, New York.

Dwight E. Robinson, formerly eastern railway representative of the Acme White Lead & Color Works, Detroit, has been elected vice-president and treasurer of Thornton N. Motley & Co., Inc., manufacturers' agents, Grand Central Terminal, New York.

Homer C. Johnstone, formerly with the Midvale Steel Company, has been appointed manager of the steel department of Gaston, Williams & Wigmore, Inc., New York. Mr. Johnstone served for 14 years as manager of the Chicago and New York offices of the Midvale Company.

The Jones & Laughlin Steel Company, Pittsburgh, Pa., intends soon to establish a large warehouse in St. Paul, Minn., to handle its greatly increasing northwest business. This company has extensive mine holdings in Minnesota and operates its own steamship line on the great lakes.

The H. W. Johns-Manville Company, New York, has opened a new branch office at Great Falls, Mont. The office is at room 418, Ford building, and is in charge of J. H. Roe. With the opening of the Great Falls office the H. W. Johns-Manville Company increases the number of its branches to 55.

C. R. Ahrens, formerly storekeeper of the Delaware, Lackawanna & Western, in charge of maintenance of way supplies, including signal materials, has resigned from his position, and become connected with the Signal Accessories Company, Utica, N. Y. His headquarters are at 30 Church street, New York.

The Harrison Railway Specialties Company, Chicago, Ill., has secured an order for Harrison dust guards for the 4,000 freight cars being built by the Bettendorf Company, of Bettendorf, Iowa, for the Russian government. The Harrison

guard was passed upon and adopted by the Russian Imperial Railway Commission.

Charles Lounsbury has recently been made president and general manager of the American Railway Supply Company, 134 Charles street, New York City. Mr. Lounsbury was born in New York City in 1868 and is a graduate of the College of the City of New York. He began his business career in 1887 with the American Railway Supply Company as junior clerk and has been with that company in various capacities ever since.

The Burnside Steel Company, Chicago, Ill., has been incorporated with a capital stock of \$100,000. It has purchased a tract of land at Ninety-second street and Kimbark avenue, and is erecting an 80-ft. by 200-ft. foundry building, a 30-ft. by 50-ft. office and pattern storage building, together with material bins, etc. It will produce steel castings and is installing a side blow converter. It will be ready for operation on December 1, this year. The office of the company is at 548 Railway Exchange building, Chicago. H. F. Wardwell is president, and C. S. Daniels, secretary.

H. W. Finnell, general manager of the Henry Giessel Company, Chicago, has been elected vice-president of Templeton, Kenly & Co., Ltd., Chicago, manufacturers of Simplex

jacks. He will be in charge of sales and assumed his new position on October 1. Mr. Finnell started his business career in the rolling mills of the National Tube Company at McKeesport, Pa., in 1899. He worked his way into the sales department, but left the company in 1901 to enter the service of the Wheeling Steel & Iron Company. In 1904 he left the position of assistant sales manager of that company and tried his luck in the oil business in Indian Ter-

ritory but without success. In 1906 he joined the sales department of the Chicago Railway Equipment Company, but in 1909 he became assistant sales manager of the Carbon Steel Company, later being sales manager and then assistant to the president and at the same time president of the Mosher Water Tube Boiler Company. Prior to October 1, he was general manager of the Henry Giessel Company, Chicago. He still retains his interest in that company.

The Edgewater Steel Company, Pittsburgh, Pa., recently incorporated, has purchased the plant of the Kennedy-Stroh Corporation at Oakmont, Pa. In addition to carrying on the lines of manufacture in steel and brass, formerly handled at this plant, new construction is now under way to give this company a well equipped plant for the manufacture of locomotive and car wheel tires, rolled steel wheels, gear rims, roll shells and turbine rings. The officers are: President, F. B. Bell; vice-president, M. R. Jackson; treasurer, W. H. Schoen; secretary, J. H. Bailly; general manager, F. C. Riddile.

G. A. White, formerly metallurgist of the American Sheet & Tin Plate Company, has become associated with the Titanium Alloy Manufacturing Company, Niagara Falls, N. Y., in the same capacity. Mr. White's long experience in the manufacture of sheet steels makes him a valuable addition to the metallurgical force of the Titanium company. Prior to his connection with the American Sheet & Tin Plate Com-

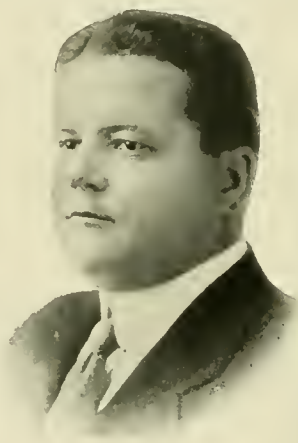

H. W. Finnell

pany, Mr. White was for a considerable time with the Rock Island and also with the Eastern Steel Company, Pottsville, Pa., where he was engaged in the manufacture of structural material. It is, however, in the manufacture and treatment of sheet steel that Mr. White has done his most notable work.

J. P. Landreth, formerly Chicago manager of the Garlock Packing Company, Palmyra, N. Y., has been appointed western sales manager of the Anchor Packing Company, Philadelphia, Pa., with headquarters at Chicago. Mr. Landreth was born at Beloit, Kan., on August 11, 1883, and attended the public schools and a business college at Joplin, Mo., and the Missouri Military Academy at Mexico, Mo. His first business connection was with the Joplin (Mo.) Water Works Company as collector and inspector of accounts. Later he was employed as car clerk on the Denver & Rio Grande, at Salida, Colo., and in 1902 took



J. P. Landreth

a position with the English Iron Works, at Kansas City, Mo., where he gained a knowledge of steam railway specialties which qualified him for a sales position in this line in St. Louis. In the spring of 1904, he became associated with the Garlock Packing Company as traveling salesman and on January 1, 1905, was transferred to St. Louis, Mo., as city salesman. In the fall of 1906, he took charge of the Kansas City office of the same company, and in May, 1908, he was made Chicago manager.

Robert Cochran McKinney, chairman of the board of directors of the Niles-Bement-Pond Company, Plainfield, N. J., died at his summer residence in Belle Haven, Conn., after an illness of more than two years. He was born at Troy, New York, but in 1861 he moved to Cincinnati where he attended the public schools and Woodward High School until eighteen years of age. He next took a partial course in mechanical engineering in Cornell University. His student life was followed by employment in the draughting room and office of a company which manufactured steam pumping machinery at Hamilton,



Col. R. C. McKinney

Ohio. In 1877 Mr. McKinney became associated with the Niles Tool Works and within two years was elected secretary of the company. A short time later he became treasurer and general manager. While with this company he had gained the title of Colonel through his service on the staff of Governor Bushnell, of Ohio. During the reorganization of the Niles Tool Works, necessitated on account of the rapidly expanding business, Colonel McKinney was pre-eminent.

In 1898 the Pond Machine Tool Company, Plainfield, New Jersey, was purchased, and options were obtained on the works of Bement, Niles & Company, Philadelphia, Pa., as well as the Philadelphia Engineering Works. Thus the present Niles-Bement-Pond Company, was created and Colonel McKinney was elected president of the company, in recognition of his achievement in creating and perfecting its organization.

The Willard Storage Battery Company, Cleveland, Ohio, announces the following appointments: Lester B. Knight, eastern representative, railway department, with headquarters at New York; E. L. Myers, western representative of railway department, with headquarters at Chicago, with jurisdiction over all territory west of the Ohio and Mississippi rivers, and I. R. Wentworth, representative of railway department at Chicago. Mr. Knight was, prior to September, 1915, chief electrician of electric car lighting on the Boston & Albany. Mr. Myers has been in the service of the Willard Storage Battery Company since December 1, 1913. From 1909 to 1913 he was chief electrician of the National Railways of Mexico.

William A. Austin, until recently connected with the Lima Locomotive Corporation, Lima, Ohio, as chief engineer, has formed a company called the Austin Engineering Associates, which has offices in the McCormick building, Chicago. This firm will conduct a general consulting engineering business, but will specialize chiefly on railway motive power and equipment. Mr. Austin was born in London, England, in 1874, and received his early education in a private school there. On coming to America, he continued his education in the public schools of Philadelphia, Pa., and then took up more advanced studies at the Technical



W. A. Austin

High School in that city. His first service in railway work was with the Baldwin Locomotive Works, with which company he became connected in 1892, as draftsman. He was later made designer, assistant chief draftsman and assistant mechanical engineer. This last named position carried the entire duties of estimating engineer in charge of preliminary analyses, estimates, plans and general design in conjunction with the sales department. In 1912 he became associated with the Lima Locomotive Corporation as chief engineer in charge of all engineering design and estimating, and he also served as general field representative for the sales department in technical matters. During the period Mr. Austin was with the Baldwin Locomotive Works he participated directly in the development of the Mallet type of locomotive in this country, in the early application of the Walschaert valve gear to American locomotives and he was co-developer of the much used Ragonnet reversing gear. He also assisted the engineers of the Southern Pacific and Union Pacific systems in perfecting common locomotive standards for these lines. He is inventor of the Austin trailer-truck, successfully applied to many Lima locomotives for trunk line service. He has invented other devices used in locomotive construction, including a screw reverse gear adopted by the Southern Pacific, an outside steam pipe cover which is used on many superheater engines, a hose strainer coupling connection between engine

and tender, as well as improvements in rack-rail locomotives and gear-driven engines.

J. E. Buker, general sales manager of the Chicago Car Heating Company, Chicago, Ill., has been elected vice-president, effective October 15. He was born in Jefferson county, New York, where he received his early education. Upon leaving school, he entered the mechanical department of the Michigan Central, where he remained about twelve years. Seeing a chance to acquire some very special mechanical experience with another company he obtained employment with the Atchison, Topeka & Santa Fe. Two years later he accepted a position with the Hicks Stock Car Company, as general manager, with which concern he was connected nine years. He then became assistant superintendent of machinery of the Illinois Central, holding this position for eleven years. Following his resignation from this company in 1910, he became associated with the Chicago Car Heating Company.

Oliver J. Smith, whose appointment as manager of the Lima Locomotive Corporation, has recently been announced, was born January 20, 1883, at South Dayton, N. Y. After an elementary education in the public schools of his native town he entered the high school at Jamestown, N. Y. In July, 1899, he took employment with the American Locomotive Company as an apprentice, remaining with this company until 1906 when he went to the Lake Shore & Michigan Southern shops at Collinwood, Ohio, as an expert machinist. In 1907 he returned to the American Locomotive Company's plant at Dunkirk, N. Y. In 1910 he was promoted and transferred to the New York office of this same company as piece work supervisor, which position he held until August 1 of this present year, when his appointment as manager of the Lima Locomotive Corporation became effective.

W. P. Barba, vice-president of the Midvale Steel Company, Worth Brothers Company and the Wilmington Steel Company, has resigned, and the duties of vice-president of these three companies will be assumed by E. E. Slick, vice-president of the Cambria Steel Company. Mr. Barba will take a few months' rest and travel before taking up some special work along the lines of his wide experience at Midvale; he does not intend to undertake the same character of work that he is now relinquishing. Mr. Barba had been in the employ of the Midvale Steel Company for 36 years. Entering Midvale in 1880 as a boy, in nine years he was made chief chemist, then department superintendent, and not long after, general manager of sales. A few years ago he was made general superintendent, and upon the resignation of the general manager he was called upon to fill that position, which he held until he was made vice-president at the time of the taking over of the plant by the Corey interests.

Articles of incorporation have been filed in Delaware for the Inter-Continental Machinery Corporation with a nominal authorized capital stock of \$500,000. It is understood that the new enterprise will deal in machinery in general, but specialize in machine tools both in the United States and foreign countries. The organization is headed by Charles N. Thorn, until recently vice-president of the Allied Machinery Company of America, which is now part of the American International Corporation. Mr. Thorn had been connected with Manning, Maxwell & Moore for 14 years. The other officers consist of Joseph S. Clark, of E. W. Clark & Co., Philadelphia; R. E. Robinson, of R. E. Robinson & Co., bankers, New York, and Chester B. Overbaugh, formerly manager of the Thompson-Starrett Company, Washington, D. C., vice-presidents, and Arthur M. Watkins, secretary. The company will establish branch offices in the principal countries of Europe, beginning with Russia, in which country the company will establish its branch in Petrograd, following with Moscow, Odessa and Vladivostok. An office and salesroom at Paris, France, and also one in London, will follow. It is also planned to open offices in China and Japan.

## CATALOGUES

**OIL ENGINES.**—Bulletin No. 154, recently issued by the De La Vergne Machine Company, New York, describes the De La Vergne type "FH" crude oil engine.

**PORTABLE TOOLS.**—Bulletin E-44, recently issued by the Chicago Pneumatic Tool Company, describes the Duntley electric sensitive drilling stand and electric drill to fit sensitive drilling stands.

**AIR COMPRESSORS.**—Bulletin 34-Z, recently issued by the Chicago Pneumatic Tool Company, deals with the company's steam driven single compressors with balanced steam valve and automatic flywheel governor.

**BURNING CRUDE OIL.**—A booklet recently issued by the De La Vergne Machine Company, New York, says that in the De La Vergne oil engine one cubic inch of oil has 6,000 sq. in. of surface all exposed to the high temperature oxygen at the same instant.

**WELDING AND CUTTING.**—The Searchlight Company, Chicago, is now distributing catalogue No. 12 on Searchlight welding and cutting equipment. The booklet, to quote from its title page, is "A book of specific information on the welding and cutting of metals by the oxy-acetylene process, together with a catalogue of the equipment necessary for such work." There are many illustrations showing the Searchlight equipment and the work for which it is adapted.

**RUBBER GOODS FOR RAILROAD SERVICE.**—This is the title of a 48-page booklet which has recently been published by the B. F. Goodrich Company, Akron, Ohio. In it are described the various items of the Goodrich line, including a complete line of hose for fire protection, pneumatic tools, air brake, steam heat, etc.; belting for axle lighting sets, conveyor belts, transmission belts, rubber matting, interlocking tiling, gaskets, insulation, etc. The book is well illustrated and is gotten up in an attractive manner throughout.

**HORIZONTAL POWER PUMPS.**—Bulletin No. 201 of the National Transit Pump & Machine Company, Oil City, Pa., is a 20-page pamphlet devoted to the company's line of horizontal piston power pumps, which are designed to cover a wide range of general service. The pumps are designed either for belt or direct connection to the prime mover and are furnished direct connected to National Transit gas and oil engines of the vertical type. The pamphlet is a complete catalogue, giving sizes and dimensions of the various types.

**TAPS AND DIES.**—The Greenfield Tap & Die Corporation, Greenfield, Mass., has issued a booklet relative to the "Gun" tap which it has recently perfected and put upon the market. This tap is especially strong and efficient. Its cutting edges at the point are ground at an angle to the axis of the tap in order to cut with a shearing action. This throws the chips, unbroken, ahead of the tap instead of allowing them to collect in and clog the flutes. A two or three flute construction is thus possible and much shallower flutes are possible than in the ordinary tap. A description of the tap appeared in the *Railway Mechanical Engineer* for August, page 429.

**SPRACO SYSTEM FOR COOLING CONDENSING WATER.**—This is the title of a 16-page booklet recently issued by the Spray Engineering Company, Boston, Mass. In the "Spraco" system the hot water is cooled by spraying it into the air so that when it falls into the basin or pond, its temperature is sufficiently reduced to permit of its being used over again. The booklet describes the system in detail, showing its advantages and the economies derived from its use and a number of views are given of Spraco systems in operation. The same company has also issued two leaflets relating respectively to the "Vaughan Flow Meter" and "Cooling Water for Ice Plants."

# Railway Mechanical Engineer

Volume 90

December, 1916

No. 12

## The Prize Competitions

It was our intention to announce in this issue the winners in the prize competitions on hot boxes under freight cars, and the benefits of convention attendance. Unfortunately the judges were unable to come to a conclusion as to the winners in either of these contests and we are forced to postpone announcement of the results until the January issue. We are greatly in hopes, however, that the decisions in both competitions will be made shortly and that we will be able to notify the winners and send out the checks early in December.

## The Making of an Executive

In studying recent annual reports of the railways four distinct improvements stand out because of marked economies which they have brought about. Without attempting to list them in the order of their importance they are, (a) increased average trainloads, which are far greater in proportion than any increases which may have resulted directly from the introduction of new and larger power, from the modernization of old locomotives, or from reduction of grades and curves; (b) marked reductions in the amount of fuel used on locomotives per unit of work done; (c) heavy reductions in the amounts paid out for loss and damage to freight; (d) a gratifying decrease in the amounts expended for loss of life and injuries.

Many things are responsible for these various savings; but underlying it all is one great force—that of education. These things were not accomplished by any one man, or any group of men. They have been fruitful only in so far as everyone having anything to do with them has been awakened to his responsibilities and has been shown how to do his particular work in a way to get the best results. Many means have been taken to bring about this awakening. Obviously, the officers first had to awaken and gain a vision of the possibilities. Publicity campaigns of one sort or another were waged. Above all, however, was the personal work done by those in charge in instructing their subordinates as to details and inspiring them to co-operate and help with their criticisms and suggestions.

Some roads have done more than others; some shops and divisions on the same road have gone far ahead of others because of their leaders and the knowledge they have been able to impart and the spirit that they have been able to inspire in their followers. It is true that in many instances material, equipment and improved facilities have played an important roll, but far more vital than these has been the better use which has been made of the human material. And this does not mean exhausting or overworking the individual. In most cases the spirit in which the task was approached by the individual really made his work easier than before. It has required a greater expenditure of brain energy and possibly less physical effort. It has caused many discouraged individuals to take a real pride in their work and to realize the possibilities and responsibilities of their positions.

We are only beginning in this country to realize the necessity for the conservation of human energy, as well as of physical energy and materials. No matter what your position may be you can find plenty of opportunities to improve the work of your gang, shop or department, if you will go at it in the right spirit. Begin with yourself and then get busy on the men under you.

## Machining Locomotive Journals

The necessity of removing the "dead" metal from punched holes in firebox sheets before applying the staybolts is generally acknowledged. That the same principle applies to locomotive axles and other similar parts of cars and locomotives is clearly brought out in the report of the investigation made of a locomotive axle failure published elsewhere in this issue. The sole cause of this accident is attributed to the fact that the finishing cut on the journal did not remove the "dead" metal caused by the heavy roughing cut taken in turning down the axle from the rough forging. This left a surface that could not withstand the bending stresses to which the axle was subjected. This surface metal gave way forming cracks in the axle itself which gradually grew larger until the axle broke.

The theory of the behavior of the axle, as presented in the report, is that the surface metal of the journal was in tension, thus tending to open up cracks in its structure, whereas had a proper finishing cut been taken and the journal properly rolled, the surface metal would have been in compression, thus resisting the bending action instead of augmenting it. This point should be carefully considered in all round parts that are subjected to a similar action. Time may be saved by taking heavy roughing cuts but sufficient metal must be left so that the finishing cut will remove all of the "dead" metal and further, where necessary, the parts should be rolled to insure a close grained metal structure.

Other points brought on in the inspector's report also showed that the general workmanship in making this axle was poor. The wheel had a very small bearing in the wheel seat, which would have caused an accident later on, and mistakes had been made in the location of the keyway.

## Locomotive Headlight Hearings

On September 1 the Interstate Commerce Commission extended until January 1, 1917, the effective date of the order requiring all new steam locomotives and all steam locomotives given a general overhauling subsequent to that date to be equipped with high power headlights with sufficient intensity to enable persons with normal vision in the cab of a locomotive, under normal weather conditions, to see a dark object the size of a man for a distance of 1,000 ft. or more ahead of the locomotive. A hearing was held at Washington during the week beginning October 30 to consider a series of tests made with electric headlights on the New York Central. Oral argu-

ments were also heard by the commission, and briefs filed, on November 27.

As will be noted elsewhere in this issue, a number of startling facts were brought out during the hearings. It is difficult to explain the position which has been taken by organized labor in advocating the adoption of the high power headlight. While it may have advantages on single track lines in sparsely settled districts of the country where traffic is light, there seems to be little question but what it is absolutely dangerous on double or multiple track lines with a heavy density of traffic. Although evidence which was presented clearly proved that the Brotherhood of Locomotive Engineers, through Grand Chief Warren S. Stone, had expelled members from the brotherhood because they had testified against the use of the high power headlight, at least 80 engineers were on hand in Washington to testify that the use of such headlights was dangerous. It is reasonable to suppose that they would hardly have taken this step at the risk of losing their insurance and other rights in the organization and incurring the displeasure of their fellows had they not held very strong convictions on the subject.

It is hard, also, to understand the attitude of the locomotive boiler inspection department at Washington in working so intimately with the brotherhood leaders in advocating the use of the high power headlight. Nor can one understand why Alonzo G. Pack, assistant chief inspector in the locomotive boiler inspection department, should, almost within the hearing of the Interstate Commerce Commission, remind one of the engineers of the brotherhood rule that he could be expelled for interfering with legislative matters of the brotherhood. There is in the federal penal code a section which prescribes a fine of \$5,000 and six years' imprisonment for intimidation or wrongful influencing of witnesses in a proceeding before a United States court or commissioner. The brotherhood leaders should be made to feel the force of this law.

It is fully realized that the members of the Interstate Commerce Commission are overburdened with duties, but in justice to the railroads it is to be hoped that each of its members can find time personally to study over the evidence which was presented at the hearings. If this is done the department of locomotive boiler inspection will undoubtedly be ordered to modify the proposed rule on high power headlights, which is not only unreasonable but dangerous, despite the assertion made by Grand Chief Stone that such headlights should be considered as a "safety device."

#### Promotions in the Mechanical Department

The following poem, which appeared in a recent number of *Power*, relative to the advancement of men in minor positions in the stationary engine field applies so thoroughly to the mechanical department of our railways that through the courtesy of *Power* we present it to our readers. There is a lot of truth in the poem and it should be carefully considered by all mechanical department officers, from the highest to the gang foreman. To most people there is something more to life than a mere three square meals a day. A man will work harder and more conscientiously if he feels that there is a possibility of future advancement in the particular line of work which he is following. Nothing is more discouraging than to bring in outside men to fill the positions immediately ahead of him. Where this is the practice the proper esprit de corps will never be obtained, and, further, it is an indication of poor organization, for no shop or department can be considered well organized in which there is not a man in the organization who has been brought up and trained to fill the openings in the administrative ranks as they may occur.

The poem speaks of the fireman in the stationary plant, but

any position in the mechanical department of a railroad can be substituted for that of the fireman and the poem will still hold good.

### THE JOB HIGHER UP

By R. T. STROHM

There are times when toil grows dreary  
And the world seems none too kind,  
And the worker's frame is weary  
With the long-continued grind;  
And the thing that keeps him going  
When his nerve and strength have fled  
Is the hope that comes with knowing  
There's a better job ahead.

He is sure to be more willing  
And less apt to lag and droop  
If he knows that oil-cup filling  
Or the swinging of a scoop  
Will not haunt the years remaining  
With its humdrum, but, instead,  
Give experience and training  
For the better job ahead.

He will throw his best endeavor  
Into every phase of work,  
And the chances are he'll never  
Be a loafer or a shirk  
If his modest occupation,  
Though it yields him meat and bread,  
Is a sort of preparation  
For a better job ahead.

Nothing kills his high ambitions  
Quite so thoroughly as when  
He observes advanced positions  
Go to new and unknown men;  
So you really cannot blame him  
If his spirit's dull and dead,  
When you don't intend to name him  
For the better job ahead.

#### The Situation at Washington

When President Wilson surrendered to the brotherhood chiefs last September he insisted that Congress should enact a law to provide not only for the establishment of an eight-hour day and the appointment of a small body of men to observe the actual results of the adoption of the eight-hour day in railway transportation, but also that the Interstate Commerce Commission should be enlarged; that Congress should consider the question of an increase of freight rates to meet the additional expenditures; that provision should be made to prevent strikes or lockouts until arbitration had been resorted to; and also that the chief executive should have the power, in case of military necessity, to take control of the railroads and rolling stock or such portions of them as might be necessary, for military purposes. It is understood that in his message to Congress, which will be presented before this issue reaches its readers, he will insist that the legislation on this program which was not attended to in September be given prompt consideration.

Meanwhile a test case as to the constitutionality of the Adamson eight-hour law has been rushed to the Supreme Court in the expectation that arguments will be heard and a decision will be handed down before the law becomes effective on January 1. Even should it become effective, a long time must elapse before it can be definitely decided just what it means and how it should be applied.

In addition to all this, the Newlands or Congressional Joint Committee on Interstate Commerce opened hearings on November 20 with a view to investigating the entire problem

of railway and public utility regulation. These hearings will extend over a considerable period and will be of a most comprehensive nature. The railroads were called upon first to state their case and make such recommendations or suggestions as they might think wise, and several days were required for the presentation of testimony by Alfred P. Thom, counsel for the Railway Executive Advisory Committee. Briefly, the railroads are in favor of a fair and stable system of regulation and to secure it they advocate that the entire power and duty of regulation should be placed in the hands of the national government, except for local or incidental questions that can be more easily handled by state authorities. An enlargement of the Interstate Commerce Commission is recommended, as well as the creation of a new federal railroad commission and regional commissions in order that prompt attention may be given to all questions which may arise in connection with railroad rates and regulation. This would make it possible for the commission to confine the suspension of rates to 60 days from the time the tariffs are filed instead of 10 months as at present. The federal incorporation of railways is also advocated, as well as giving the federal government exclusive power to supervise the issuance of securities by interstate carriers.

With all of the above mentioned agencies at work upon the railroad problem the next few months promise to be critical ones in the history of railroading. If action is taken which will provide for constructive instead of restrictive and corrective regulation, and if measures are adopted that will insure fair treatment of the railways, so that investors may be attracted instead of being repelled, it will mark a distinct advance. If, on the other hand, the present situation is allowed to remain unchanged or a narrow policy is followed, the country at large must surely suffer, for in order to extend its productive territory and have its citizens efficiently served, the railroads must very greatly increase their equipment and facilities and must enjoy at least a fair degree of prosperity.

#### Do Your Equipment Buying Early

Elsewhere in this issue figures are given showing that the railways and other users of cars and locomotives in the United States and Canada placed orders during November for 408 locomotives, 44,001 freight cars and 510 passenger cars. It is also noted that during the month orders were reported as having been placed with locomotive builders for foreign locomotives to the number of 755, or a total of both foreign and domestic locomotives of 1,163.

These purchases made November the best month, as far as new business in railway cars and locomotives is concerned, in at least the last three years. In fact, the domestic orders for locomotives exceeded those reported in the entire first six months of 1915, while the freight car total was greater than that for the first seven and one-half months of 1915. The November orders added appreciably to the 1916 totals. Domestic orders for locomotives so far reported this year now total 2,538 as compared with a total in all 12 months of last year of 1,612. Freight car orders to November 30, this year, now total 142,399 as compared with 109,792 from January 1 to December 31 last year. Passenger car orders now total 1,462 exclusive of subway, elevated and Pullman cars as against a similar figure for 12 months in 1915 of 1,467.

The amount of business that is being done in railway equipment will be even better realized when it is observed that in November contracts were reported for over \$100,000,000 worth of cars and locomotives. There were 408 domestic locomotives which, considering the large number of heavy locomotives ordered, may be put at \$30,000 each, a total of \$12,240,000; 44,001 freight cars at \$1,500 each,

\$66,001,500; and 510 passenger cars at about \$18,000 each, \$10,800,000, a total of domestic orders of \$89,041,500. To this will be added 755 foreign engines at something like \$14,000,000. In short, the purchases of cars and locomotives reported in a short 30 days have totaled, according to these conservative estimates, no less than \$103,041,500. Truly, our car and locomotive plants next year, should be showing us annual reports that will put the "war brides" in the shade.

Bear in mind that these enormous purchases are being made while prices for cars and locomotives are from 25 to 40 per cent above their normal level and while deliveries are exceedingly poor. In fact, a railway ordering equipment at the present time cannot expect delivery before June or July, 1917. The equipment market during the summer of 1916 was fairly good, but at all times there was a decided drag because of high prices, as evidenced, for example, by the large number of withdrawals of inquiries. During these months the railways could have financed heavy purchases, but they could not see their way clear to placing large contracts while there was still some chance that prices would fall again or while there were possibilities that the cars and locomotives would not be delivered before the war-time business and revenues had fallen off. It has now become apparent that no decline in prices is to be expected for some time. This and the fact that as new orders are placed, deliveries will become poorer and poorer, present the incentive for the present rush of business. The railway that has not already contracted for its requirements for many months ahead should take good note of these conditions. It can apparently gain but very little by postponing its purchases even a little while longer.

The amount of shop equipment purchased by the railways does not perhaps present quite so bright a picture as is furnished by cars and locomotives, but there is reason for gratification that the railways are now beginning to get into the market. The railways need equipment badly as a direct result of their present great activity, and it is only because of high prices and poor deliveries that they have not issued large lists of their requirements. How long they could hold off from buying tools has at all times been problematical. It is now evident that they should not hold off much longer. To be sure, deliveries are still poor though not as bad as they were. Prices are still high; they are from 40 to 70 per cent higher than they were a year ago. But as in the case of cars and locomotives, the end does not appear in sight. The railway that has not covered its machine tool requirements should "watch its step."

#### NEW BOOKS

*How to Build Up Furnace Efficiency.* By Joseph W. Hayes. Tenth edition. Bound in paper. 158 pages, 5 in. by 7 in. Published by the author, Rogers Park, Chicago, Ill. Price, \$1 postpaid.

The first edition of this book was published in 1908 and the fact that this is the tenth edition published within a period of eight years is sufficient evidence that it has been very widely read. The author is a combustion engineer, who has several publications to his credit, dealing with the technical phases of combustion and fuel economy. In the present volume, however, the aim of the author has been to treat the subject in a popular way, very little being said relative to the theory of combustion. The purpose has been to show the manager, the superintendent and the engineers and firemen of power plants, how they may proceed actually to effect economy in the consumption of fuel with results which will be felt immediately in reductions in the coal bills. The book is written in a breezy style and is well illustrated with drawings and diagrams. It also contains illustrated descriptions of such equipment as draft recorders and apparatus for gas analysis, with instructions for their use as a means of checking furnace efficiency.

## COMMUNICATIONS

### TOBESURA WENO ON THE HEADLIGHT LAW

(With apologies to Wallace Irwin.)

DEAR EDITOR:

In my previous epistle, I express grave fear of possible impeachment my job I. C. C. Federal detector. Since which I are about convince circumstance deal me four ace. I refer to headlight law by honorable commission. Some time since, big mechanical bugs confab with Chief Detector at Washington, secret test are made by prominent western RR supervised by Federal detectors under I. C. C. code prepared for occasion and entire different from crude, unscientific scheme use by federation of R.R. officials which manufacture report for amusement Atlantic City mm convention. Aforesaid scientific test develop that propose light must consume enough currents, kilowatts and mean spherical candle powers to cause normal brotherhood engineer in normal atmospheric atmosphere to detect normal dark man on track 1,000' ahead of cattle-guard when electric headlight are in normal state of preparedness. This rule No. 29 emitted by Hon. I. C. C. embody four condition of normality which are same as drawing four ace to poor jap detector like yours truly.

Dear sir, you being educated editor see quick there is 28 illegal combinations in four normalities mention—so Federal detector have same number chance to put embargo on smart-aleck mm. You understand when I flag unlimited express and inspect headlight, engineer declare he see object on track 1,000' I reject appeal immediate account not normal night-moon and stars shining. Or on dark night, engineer see man on track 1,002' away; R.R. representative laugh exulting and say O.K. but I unable to accept—man not normal dark object because he are white man, face and hands not normal dark and he sport straw hat. In same way, I can report engineer not normal on account he have cat eyes or atmosphere not normal on account dew or fog which magnify headlight beam like telescope and bring object close to view. Or, I say track not normal as dark object only 500' around curve and headlight over in corn-field.

So I have regain courage and equanimity also ability to look sassy. Rule No. 29 are going to be salvation to Federal detectors. Yours truly, TOBESURA WENO.

### BROADEN YOUR VISION!

LAS VEGAS, New Mex.

TO THE EDITOR:

It seems to me that the able articles in the recent issues of the *Railway Mechanical Engineer* and the *Railway Age Gazette* by J. T. Anthony on fire-box design and G. M. Basford on the subjects that should invite the best thoughts and efforts of young railway men of today must be productive of a great deal of good. Mr. Anthony ably traces the evolution of the firebox and considers the things that are needed to make it still more efficient. How many men will this appeal to and set thinking deeply with the set purpose of adding something to the sum total of the knowledge of the mechanical world on this most important subject? Too few, I am sure. I regret to say that the most besetting fault of railway mechanical men among those of "lower rank and lesser renown" is not to think deeply of the subjects that are most vital to the railway welfare. By far the greatest single item in railway outlay for material is the cost of fuel, and each and every thing that we can do, no matter how trivial, to reduce the sum total of this cost is well worth doing; if the thousands of mechanical men who have a direct opportunity could each add his mite the results would be indeed gratifying. No doubt we cannot all go to the heart of the matter and materially increase the efficiency of the firebox but some of us can and the rest of us can each do our part toward saving fuel and keeping the power in condition to

obtain the maximum of efficiency with the minimum of expenditure.

Thinking of our calling in this way has another beneficial effect. It ennobles our profession in our own eyes, adds dignity to the humblest task and gives us an added zest and interest in life. I sometimes wonder if railway men are less attached to their calling than other men; how many thousand times do we hear men lamenting the day that they began a railway career, and yet the fact most likely remains that they have received more of the comforts of life for the efforts they have expended than they could have in any other calling, and their discontent is solely due to the fact that they have not taken an honest personal inventory and feel themselves under-rated.

It is axiomatic that a chain is no stronger than its weakest link and an organization is no stronger than the thought and heart-felt interest of the rank and file of its personnel. When we can get the sub-foreman and his mechanics to feel a deep interest in the appliances that have been developed for saving fuel; when they will study the brick arch and give it in their minds the prominent place that it rightly deserves; when they will look upon a successful feed-water heater not as a new fangled "contraption," but as a real money saver; when they will set their minds and hearts to work on the development of pulverized fuel which is to be the real money saver of tomorrow; when they will enthusiastically approve the modern apprentice system so ably developed by Messrs. Purcell and Thomas; when they will give earnest thought and effort not only to the needs of the mechanical department but to the necessities of the operating department as well, then indeed will our progress be marked and rapid and then, too, will railway men be more content and happy in their work because an enthusiastic man cannot be other than a happy one.

Another effect of the study of our profession as outlined by Messrs. Thomas and Basford will be to raise the social status of our calling, thus making it easier for us to secure the highest class of young men to recruit our work and to take up our burdens when we are no longer able to bear them. I believe the most subtle influence at work in the last decade to prevent the better class of young men from becoming mechanics has been a certain form of snobbery that decries against a man in overclothes. This, I believe, is passing away and the sturdy words recently uttered by Charles M. Schwab, that bare hands grip success better than kid gloves, are indicative of a feeling that is growing and that should be fostered.

Going back to the first proposition, I believe that such articles as those of Mr. Anthony, Mr. Thomas and Mr. Basford will do a world of good because they will teach railway men to think more deeply of the great problems involved in what I feel may be rightly termed the science of mechanics and of men, and I do not think any greater good could be done by railway officials than to induce every earnest thinker and worker to become a subscriber and a student of the leading railway magazines, magazines that disseminate all that is soundest and best in modern railway theory and practice.

T. T. RYAN,

Division Foreman, Atchison, Topeka & Santa Fe.

EXPORTS OF RAILWAY SUPPLIES.—Exports of railroad supplies from the United States for the seven months ending with July amounted to \$36,215,000, as compared with \$9,465,000 for the same period of the preceding year, according to the statement issued by the Department of Commerce. Railway cars increased in value from \$1,767,000 to \$18,093,000, largely because of the purchases made by the Russian government for the equipment of its new lines, which have been rushed during the war. Locomotives numbered 363, of which 111 went to Europe, 39 to Canada, 70 to Cuba, 21 to Mexico, and 72 to Russia.



# TRAVELING ENGINEERS' CONVENTION

## Reports and Discussion on Handling Freight Trains, Assignment of Power and Superheaters

THE report of the proceeding of the first part of the convention of the Traveling Engineers' Association at Chicago was published in the *Railway Mechanical Engineer* of November, page 561. Following is a report of the remaining sessions:

### SUPERHEATER LOCOMOTIVES

[The question of the advantages of superheaters, brick arches and other modern appliances, on large locomotives, especially those of the Mallet type, was continued over from last year, the report of the committee remaining substantially the same. This will be found in the *Railway Age Gazette, Mechanical Edition*, for October, 1915, page 499, under the heading of Modern Appliances on Large Locomotives. The discussion of the report this year centered on the subject of superheaters.—Editor.]

W. A. Buckbee (Locomotive Superheater Company):—In some instances where superheaters have been applied to locomotives and no other change has been made in the design of the locomotives, it has been found that the tonnage can be increased about 10 per cent. The reason for this is the increase in boiler capacity and the shorter cutoff at which the engine may be run. It is well known that the efficiency of the superheater increases the harder the engine is worked which means that the steam supply is greater. In many cases the diameter of the cylinders has been increased with the application of superheaters, but where this is done the factor of adhesion must be carefully considered. In some cases it is advisable to increase the cylinder diameter and to decrease the boiler pressure, keeping the same tractive effort. This not only saves fuel, but also increases the life of the boiler. As to whether or not superheater engines will start a train better than a saturated steam engine, it has been found that with the cylinders hot, superheater engines of the same tractive effort will start a train that a saturated steam engine will not. The reason for this is that the steam will pass through the cylinders without being condensed. In the saturated engine the steam that is condensed in the cylinder evaporates back into steam as soon as the pressure has been reduced sufficiently and thus produces a large volume of steam which must be forced out through the nozzle. With the superheater engine this is not so and for that reason the nozzle sometimes is reduced in area. By heating the cylinders of superheater engines by passing steam through them and out through the cylinder cocks a much smoother and easier start can be made with long heavy trains that have been standing for some time.

F. P. Roesch (E. P. & S. W.):—In order to obtain the full benefit of superheated steam in locomotives the engines must be so maintained that the full amount of superheat will be obtained. A pyrometer is absolutely necessary to determine this. When the temperature of the steam is below 570 deg., the economy is not being obtained. The difference between the correct temperature and an inefficient temperature is so hard to detect in the operation of locomotives, especially where they are used in pool service, that no engineer can be expected to tell whether or not he is getting the proper degree of superheat without a pyrometer. The superheater flues should be kept clean, and the water should not be carried too high in the boiler. On the El Paso & Southwestern a foaming water is used which if carried too high in the boiler will pass over into the superheater units, and deposit scale on the inside of the tubes, which, of course, decreases the efficiency of the superheater. This can only be detected,

however, by the use of the pyrometer. Steam leaks in the cylinder should also be watched carefully. Superheated steam is thinner than saturated steam and will pass through smaller openings. It is more difficult to determine these classes of leaks on superheater engines than it is on saturated engines. Steam should be admitted to the cylinders when drifting in order to give them the proper lubrication. From investigations of drifting valves we have found that a drifting valve sufficient to keep the relief valve closed at 37 m. p. h. requires just about one-half a ton of coal per day, which, in our district, means approximately \$2.30. We find that the brick arch is absolutely necessary in connection with the superheater if full benefits from its use are to be obtained. By the use of the arch 40 deg. more superheat is obtained than when the arch is not used, and on starting this difference is 100 deg.

L. R. Pyle (M. St. P. & S. S. M.):—We find that it is necessary for superheater engines to be equipped with drifting valves, and have found them to be cheaper than working steam when the engine is drifting. The relief valves are closed entirely. The fireman will be able to fire a locomotive better where pyrometers are used. He does not have to rely on the boiler gage at all. If he can keep his engine up to the proper degree of superheat he will have no difficulty in keeping up the proper boiler pressure.

B. J. Feeny (I. C.):—The condition of the locomotive boiler changes so slowly that it is impossible to detect it without the pyrometer. It has been found that 9 out of 10 holes in the smokebox, through which the outside steam pipes pass on superheater engines, become leaky. This has been stopped by calking these openings with asbestos packing.

Other members spoke on the efficiency obtained from the use of superheater locomotives. On one road where 20 engines have been converted to superheaters with no other change, the slide valves and the Stephenson valve motion being retained, the tonnage handled by the engines was increased from 3,600 to 4,000, with the working pressure of the boiler reduced from 200 lb. to 185 lb. The engines do not have to be worked any harder. It was believed by some that due to the absence of condensation in the cylinders, and also to the higher degree of temperature of the cylinders, the mean effective pressure of a superheater engine was higher under the same conditions as a similar locomotive using saturated steam. It was generally reported that better time could be made and more tonnage could be handled with the superheater engine at a lower fuel and water consumption. In Mallet engines it has been found that the temperature of the steam in the low pressure steam chest is 15 to 18 deg. hotter in superheater engines than in saturated engines. The question of oil to be used was discussed but it was the general opinion that if the air was kept out of the cylinders while they are hot no trouble would be experienced with the oil.

### HANDLING FREIGHT TRAINS

The purpose of this report is to recommend proper methods for making up and handling modern freight trains on both level and steep grades, so that the smallest amount of damage will be done to the draft gear. It may be recommended that:

All passing tracks, stations, water tanks, and, in fact, any place where heavy trains have to stop, should be located on such a grade that the train may be stopped without either severe pushing or pulling action on the draft gear.

All unnecessary stops should be cut out.

The brake piston travel should be kept uniform, brake

pipe leakage be kept down to a reasonable amount, retainers and their piping be kept in absolutely good condition, good pumps be placed on the locomotives which will furnish the necessary air to handle the brakes.

The engineer should be thoroughly instructed in the handling of the brake equipment.

Special attention should be paid to the inspection of draft gear at terminals.

Records should be kept of the individual performance of engineers on train handling, and they should be required to make a written statement as to the cause of the damage to the draft gear on the trains they handle.

*Yard Switching.*—Much of the damage to draft gear is done in switching. It has been found that when a bunch of cars was coupled up at a speed of 5 m. p. h., there was a buffing stress of 255,000 lb. In taking slack to cut off a dynamometer car, which was 21 cars from the engine, a shock of 78,000 lb. was experienced. It will be seen from this that too much care cannot be exercised in handling cars by all concerned.

The committee recommends that uniform instructions be given to cover local conditions as to the proper manner in which to handle the cars and trains in different yards, also that hand brakes be kept in good condition, so the yard men can stop the cars by them if necessary.

*Make-Up of Trains.*—The ideal arrangement of a train of empties and loads would be to so alternate them as to produce, as nearly as practicable, a uniform degree of retardation throughout the train, but this would obviously be impracticable. Tests have shown that, where possible, about one-third of the empties should be placed next to the engine and ahead of any loads, or else scatter the loads throughout the train and not allow them to be bunched in any one place.

From the tests it was found that the maximum stress reached under any conditions with a train made up as above was 92,000 lb., while the maximum stress with the loads all behind was 223,000 lb., or two and one-half times greater, and with the loads all ahead 150,000 lb., or 60,000 lb. greater than experienced where the loads were near the middle of the train. A record of the tests above mentioned follows:

Test No. 1.—This test was made with a train of 12 empties, then 10 loads, the dynamometer car and 21 empties. The throttle was closed at a speed of 22 m. p. h. and 30 seconds was allowed for the slack to bunch in the train. A 15-lb. brake application was then made at the engine and the train was allowed to stop. There was a buff of 20,000 lb. when the slack ran in after the throttle was closed and before the brakes were applied, and a final pulling stress of 50,000 lb. just before the train came to a stop.

Test No. 2.—The same make-up of train was used and the same routine was followed, but the brakes were applied when a speed of 15 m. p. h. was reached. The slack bunched and the train was allowed to stop. A buff of 39,000 lb. was experienced when slack ran in, and a final jerk of 92,000 lb. pulling strain was obtained at the moment of stopping.

Test No. 3.—The same train and make-up was used. At a speed of 12 m. p. h., with the slack bunched, the brakes were applied in emergency. A buff of 50,000 lb. was experienced when the slack ran in and a 58,000 lb. jerk at the moment of stopping.

Test No. 4.—The train consisted of 31 empties, the dynamometer car and then 10 loads. At a speed of 22½ m. p. h. the brakes were applied with a 12-lb. reduction immediately after closing the engine throttle. With the train still stretched a buff of 120,000 lb. was experienced and there was a constant pushing strain of 50,000 lb. until the stop was completed.

Test No. 5.—This test was made with the same train, but the slack was allowed to bunch before the brakes were applied, and in bunching after the throttle was closed a buff

of 40,000 lb. was experienced with a final buffing strain of 74,000 lb. at the time of stopping.

Test No. 6.—The same train was used and at a speed of 10 m. p. h. the brakes were applied in emergency immediately after closing the throttle, and three buffing shocks were experienced. The first was 223,000 lb., the second was 180,000 lb. and the third was 177,000 lb.

Test No. 7.—The same train was used and a 15-lb. brake application was made at a speed of 11 m. p. h. While the slack was stretched a buffing shock of 87,500 lb. was experienced.

Test No. 8.—The same train was used. When backing up to kick off the caboose, a 9-lb. reduction being made at a speed of 6 m. p. h., two jerks were experienced, one 80,000 lb., the other 120,000 lb.

Test No. 9.—Moving ahead at 4 m. p. h. with the same train, an 8-lb. reduction being made, the buffing experienced was 100,000 lb.

Test No. 12.—The train was made up of 10 loads, the dynamometer car and 31 empties. At a speed of 20 m. p. h. and after the throttle had been closed and the slack allowed to bunch, a 12-lb. service application was made from the engine and the train allowed to stop. During this test a constant pulling strain of 150,000 lb. was experienced.

Test No. 13.—With the same train, a 10-lb. service application was made at a speed of 12 m. p. h. When the brakes took hold on the rear end a jerk of 132,000 lb. was had; the train parted by breaking the drawbar in the fourteenth car from the engine and three cars behind the dynamometer car.

#### EMPTY AND LOAD BRAKE

One of the most fruitful causes of damage to draft gear is the difference in braking power between empty and loaded cars. This is the reason why so much stress is laid upon the importance of mixing the loads and empties in such a manner that the unequal strains will be spread over the train so that it will not do damage.

Braking power on cars varies in different parts of the country from 60 per cent to 80 per cent of the light weight of the car, and drops to from 17 per cent to 30 per cent when the car is loaded. Now, then, if we could get a brake equipment which would give a uniform braking power with both empty and loaded cars, we will be in a position to handle long, heavy freight trains faster and with less damage to draft gear and with greater safety.

In the new empty and load brake, which has been introduced on several roads, we have to a great extent such a brake. On one road the cars have a standard braking power of 50 per cent of the light weight of the car, and when loaded and cut into load position they have 40 per cent of the weight of the car, or a loss of only 10 per cent in braking power when the car is loaded as against a loss of 40 per cent to 43 per cent with the single capacity brake.

The reports concerning this brake indicate that it will increase the hauling capacity of a road handling heavy trains down steep grades and tend to increase the safety of the operation of trains.

Following is a summary of tests of the empty and load brake made with a dynamometer car on the road:

The greater safety, control capacity and economy possible by the use of the empty and load equipment is illustrated by the fact that when the same brake pipe reduction was made with a 90-car train having 30 empty and load brake equipments on the head end, and also with a 90-car train with single capacity brake equipment, both on a tangent of 1½ per cent grade and at a speed of about 21 m. p. h., the train with the empty and load equipment on the first 30 cars was stalled, whereas the speed of the other train was only reduced to about 8 m. p. h. The average brake pipe reductions required to control the 90-car train with the 30 empty and load brake cars on the head end was only half

as great as with the 90-car train of all single capacity brakes. The single capacity brake train could not be re-charged as promptly or as uniformly as the other, because 100 per cent heavier brake pipe reductions had to be made.

The average speed on the grade was about 16½ m. p. h. for the train without empty and load brakes, and about 19 m. p. h. for the train having empty and load brakes (30 on the head end). This shows that a higher speed can be secured, thus increasing the capacity of the road, and at the same time a greater factor of safety in operation is afforded by the use of the empty and load brake equipment.

Just preceding the final application at the foot of the grade with the train having all single capacity brakes, the brake pipe pressure was only 78 lb. instead of 91 lb., as it was at the start. With the similar train having 30 empty and load equipments on the head end the brake pipe pressure preceding each successive application was 93 lb.

With both the 90 and 100-car trains having empty and load equipments there was an average reserve braking force available at all times during the descent of the grade such that at any time the forces being employed might have been increased by from 35 per cent to 55 per cent as occasion demanded. On the other hand, the train without empty and load equipment was being taxed to its capacity throughout the descent of the grade.

The best estimate possible from the data at hand shows that only about 48 per cent of the maximum available air supply was required in the handling of the train having empty and load equipment, whereas it was necessary to use about 54.5 per cent of the maximum compressor capacity for the train not having empty and load equipments.

Emergency stops from 23 m. p. h. on the grades with trains consisting of one locomotive, dynamometer car, six loaded coal cars and caboose (brake on locomotive and caboose cut out) were made in an average distance of 1,780 ft. when the cars were equipped with single capacity brakes. A similar train having cars equipped with empty and load brakes was stopped from the same speed in approximately 720 ft., 40 per cent of the distance required to stop with the single capacity brake.

[The report also included quite complete instructions for freight train handling, including instructions for engineers, train conductors and others who have to do with this work.—Editor.]

The committee is: L. R. Pyle, chairman, (Soo Line); E. F. Boyle, (Sunset Central); W. G. Wallace, (Am. Steel Foundries); Wm. Owens, (N. Y. Air Brake), and C. W. Irving, (N. & W.).

#### DISCUSSION

Walter V. Turner (Westinghouse Air Brake Co.):—Where the brake equipment is not properly maintained it is very difficult to give the engineer any definite instructions as to how he should handle his train. Brake piston travel has a very vital bearing on the performance of the brakes, and where this is not maintained to the proper amount it is impossible to get smooth action. It must be remembered that the shocks are caused by the difference in velocity between the cars. This difference in velocity is caused, to a very large extent, by the unequal braking power on the different cars. A difference of one mile per hour in the velocity of two cars produces a shock between the cars equal to the weight of one of the vehicles, provided they are of the same weight. It is therefore very important that the braking power be maintained as nearly constant as possible throughout the train, which means that the piston travel should be up to standard. No brake pipe reduction should be made, such that would cause a difference of velocity between any two cars in the train of 2 m. p. h., as this is almost sure to cause damage to the draft rigging. The best brake is one that produces the least velocity difference between the cars, and which will apply simultaneously; otherwise low reductions must be made if

no shocks are to be obtained. To obtain proper train operation it is necessary to start back of the manipulation of the brake valve. In other words, the brake equipment of the cars must be of the proper design and be maintained properly. With the heavier cars in long trains the empty and load brake is found to be necessary. Cars of 315,000 lb. capacity are now being built. If the single capacity brakes were used on these cars it would require a 22-in. brake cylinder to properly brake a 100-car train, and this, of course, is impossible under existing conditions. With the empty and load brake the capacity of the brake is increased 3½ times, and 60 per cent as much air is used as in the 10-in. single capacity brake. The air consumption of the brake system is an all-important factor in the long and heavy trains of today.

The principal feature of the empty and load brake is that it can handle heavier cars at greater speeds and it is just as desirable and necessary for heavy cars in long trains on level track as on grades. It not only permits of better handling of the trains but decreases the cost of maintenance of the cars, inasmuch as they are handled more smoothly. Smooth braking cannot be expected for present day train service from the single capacity brake on account of the inherent defects in its design. The acceptance of the improvements in air brake design has not accompanied the development in car and locomotive design, but it is necessary that they go hand in hand. It is just as important to control the speed of the new equipment as it is to build it.

T. F. Lyons (N. Y. C.):—It pays to make haste slowly in braking the long, heavy trains of today. While the paper recommends two reductions in the train line pressure to make a stop, it appears to me that one reduction would be better, as every time the brake pipe pressure is reduced you take just one more chance on the poor operation of your brakes. Terminal tests are very important and should be made. The use of sand to start sliding wheels rotating again is of no avail and will only increase the length of the flat spot on the wheel. In making coal and water stops in cities where there are many crossings it is better to stop the train and draw it up to the water plug slowly, rather than to cut off from the train and run to the water plug light. By doing this the train will be ready to start after the engine has received coal and water, and will block the crossing for a much shorter time.

F. P. Roesch (E. P. & S. W.):—Break-in-twos are due very often to defects in the draft arrangement caused by rough handling in the yards. It is estimated that fully 60 per cent of the damage to freight equipment originates in the yards. The defective equipment gets out on the road unnoticed, especially at night, when it is difficult to properly inspect the cars. One break-in-two out on the road caused by this defective equipment will attract more attention than a similar accident in the yards, and the engineer is often held to blame when it is really the fault of the men in the yards and the inspectors who let the defective equipment get out on the road.

G. H. Wood (A. T. & S. F.):—It has been found better to work steam on the locomotive close up to the stop on long trains. This will tend to keep the slack out and prevent any trouble from the shock due to the slack running in heavily. It must be remembered that the instructions given by the committee cannot be considered as a panacea for all evils. They show what should be done under average conditions. It is my opinion that fully 75 per cent of the damage to the equipment is done in the yards, and that every means should be taken to prevent any defective equipment from getting out on the road. On the Santa Fe the terminal tests include stretching the train to locate undue slack in the draft arrangement.

W. G. Wallace (American Steel Foundries):—Many of the break-in-twos occurring on the road are occasioned by

improper attention to draft rigging at the terminals. It is important that the draft gears be maintained properly, and that excessive slack be eliminated. It might be well to stencil on the side of the car the proper length of draft gear travel in order that this may readily be determined. The practice of the Santa Fe in stretching its trains in terminals to determine the slack is a very good idea.

H. F. Henson (N. & W.):—Careful supervision of the engineers in handling trains is necessary for good performance. Sufficient time should be given at the terminals for careful inspection and especially upon leaving the classification yards. The engineer is many times held responsible for accidents that should really not be chargeable to him. The knuckle pins should be carefully examined. Many of them are too short for the service they are required to give. For long trains sufficient reservoir capacity should be provided on the engine, and the reservoirs should be kept well drained of water.

L. R. Pyle (Committee chairman):—All the recommendations of the committee are based on the assumption that the brake equipment is maintained properly. We should never ask an engineer to do anything unless the equipment is in condition to do it and that we could not do ourselves. Attention must be given to the handling of the cars in the yards. The number of break-in-twos can be diminished if proper effort, organization and concentration is placed upon it. I know of one specific case where 100 break-in-twos per month were reduced to 26 by simply getting after them and following them up. The traveling engineer should make recommendations concerning the makeup of trains. He is "the eye" of the mechanical department, right on the firing line where he can watch things carefully, and should not hesitate to make recommendations for improvements in the handling of the equipment, for if he don't there is no one so well situated to see these things that will. We must not charge all break-in-twos to bad equipment, of course. There is undoubtedly a lot of it occasioned by improper handling of the train by the engineer.

**ASSIGNMENT OF POWER**

The officer that assigns the power to the sub-divisions on the system should be a man who understands the construction of the different type locomotives and who also understands the requirements of the sub-divisions on which the power will have to work. This officer should have absolute authority and report direct to either the general manager or superintendent of transportation, or general superintendent of motive power, and should at all times keep in close touch with these general officers. He should have an organization with an assistant or assistants on each sub-division to co-operate with the local officers, and conduct tests with reference to tonnage and fuel economy.

Assigning of power with reference to density of traffic is very important; the less train miles made the most economical the operation. The grade line and the shop facilities for caring for the engines should also be considered. The power should be run to or from some point which has the necessary facilities for caring for it, except in isolated cases of engines working on runs and coming to the shop every one or two weeks, as the case may be.

The assigning of engines with regularly assigned engine crews versus the pooled system, is a most important question, which, to a large extent, is governed by local conditions. It is possible to run engines successfully and economically over more than one division in continued service. This will save terminal consumption of fuel and reduction in mechanical forces at intermediate points. At the end of the engine's run it should be thoroughly inspected and all necessary work done. With our modern passenger engines equipped with brick arches and superheaters it is possible to run them from 200 to 350 miles over two or three divisions. The

advantages in assigning regular men on engines would apply where the power is old and facilities for caring for power are limited, such as branch line service and all locals, and on runs that tie up at outlying points.

A number of roads have shown that engines can be pooled successfully and economically, provided there is a proper organization to inspect and repair them.

The condition of power reflects—first, the class of work that the roundhouse foreman will accept from his mechanic; second, lack of personal inspection by the local mechanical officers and failure to keep in close personal touch with the mechanical condition of the power.

**ENGINE MILEAGE**

Every effort should be made to increase the mileage of the power, the result of which is increased earnings on the capital invested, decreased cost of engine handling and less overcrowding at terminals, which automatically increases the mechanical facilities without increasing the expenditure and reduces the terminal consumption of fuel. The larger earning power created guarantees quicker returns and permits quicker retirement of power. Railway companies are finding that by converting saturated steam engines to superheaters increased mileage can be successfully made.

A recent striking example of what can be accomplished by running power through and over two divisions has come under the observation of the writer on two freight divisions of 120 and 119 miles respectively, making a total of 239 miles. A number of 49,000-lb. tractive effort superheated Consolidation locomotives have been used for several years for handling all freight business, much of which is expedite freight. The freight engines were run through from Springfield, Mo., to St. Louis, crews changing at Newburg, and engines making mileage of 239 miles. A careful check for sixty days, including the months of May and June, showed the following results:

Engines run through made.....	133,000 engine miles
Engines not run through made.....	52,000 engine miles
Fuel used per 1,000 gross ton miles, through service.....	159 lb.
Fuel used per 1,000 gross ton miles, not run through.....	178 lb.
Saving in favor of engines that went through.....	\$2,611

Equals a saving of 10.7 per cent.

Reduced force at intermediate point, account going through.....	\$1,260
Total for two months.....	\$3,871
At same rate will show annual saving.....	\$23,226

Also, five engines were removed from the division and used elsewhere, in face of increased business of 20 per cent in train miles per mile of road or 246 train miles per mile of road a year ago and 299 train miles per mile of road in 1916 on this territory.

The reason that all engines are not run through is due to grade, line and operating conditions, which require turn-arounds to be made.

The following passenger engine mileage is made between terminals before the engine is relieved, one, two and in some cases three crews manning the same engine:

Springfield to St. Louis.....	239 miles
Springfield to Memphis.....	282 miles
St. Louis to Monett.....	283 miles
Springfield to Oklahoma City.....	304 miles
Capula to Sherman.....	207 miles
Springfield to Kansas City.....	204 miles
Springfield to Ft. Smith.....	178 miles
Kansas City to Oklahoma City.....	378 miles
Memphis to Birmingham.....	251 miles
Memphis to St. Louis.....	318 miles
Monett to Wichita.....	239 miles
Making an average run of.....	262 miles

From 6,000 to 10,500 miles per month are made with passenger engines. Taking, for instance, the run from Memphis to St. Louis, 318 miles, four runs are handled with five engines—one to protect. The accumulative mileage will require that one of these engines shall go through the shop every ninety days for general repairs, as every ninety days one of the five engines has made more than 114,000 miles.

To bring about the necessary co-operation of all departments, which is absolutely essential when making power

assignment requiring engines to cover more territory, the endorsement and prestige of the general manager or some other high operating official is required.

Proper inspection, close attention to the work reported by the engine crews and inspectors, proper building up of fires by the roundhouse help, and handling by the fireman after the engine is turned over to him, good handling by the engineer to prevent slipping and when leaving the initial terminal to prevent turning over the fire and starting clinkers are all items that must be watched if the best results are to be obtained. The entire proposition resolves itself into an engine and fire condition, both of which must be watched by proper officers and exceptions taken to any adverse handling or engine condition that will cause the crew to work under a handicap.

The officer responsible for assignment of power should have a personal knowledge of track and bridge conditions, and this feature is one that should be especially considered on branch line territory.

Another feature that should be given serious consideration in assigning power is where a limited number of superheater engines are available, the conditions being equal, the superheated power should be assigned in territory and on divisions where company coal haul is longest and where company fuel costs the most, thereby decreasing the cost of company coal and increasing the revenue train haul.

Some of the factors contributing to successful assignment of power are a thorough knowledge of the condition and capacity of the power, of the business requirements and co-operation between the departments.

The committee is: P. O. Wood, chairman (St. L. & S. F.); J. D. Heyburn (St. L. & S. F.); D. Meadows (M. C.); F. R. Melcher (C. & N. W.), and W. H. Corbett (M. C.).

#### DISCUSSION

W. L. Robinson (B. & O.):—The effect of pooling engines may be shown, perhaps, in a general way, by referring to the annual statistics published by the Interstate Commerce Commission. In 1904 a great many railroads followed the system of assigning a regular engine to the crews, while in 1914 most of these railroads were using the pooled system. During that time the average tractive effort of the locomotives increased 38.6 per cent, while the ton-miles per freight locomotive only increased 11.3 per cent. This may be due to the fact that the engines do not give the service under the pooled system that they would where they are assigned. In the annual report of one large railroad, however, the assignment of power is attributed largely to the decrease in operating costs. With an increase of \$7,000,000 in business there was a decrease of \$347,000 in operating cost and a decrease of \$89,000 in fuel cost, which was attributed, by the general manager of that road, to the assignment of power. Regardless of this fact, it is apparent that the management of most roads prefer the pooled system, and we should acknowledge this and make the best of it, and keep the engines in the best possible condition, having the shops ready to make quick and proper repairs.

C. W. Irving (N. & W.):—On one division of the Norfolk & Western there are 10 Mallet locomotives in assigned service. These are always to be found ready for their trips and seldom get to the back shop for repairs more than once in 18 months. The men take an interest in their engines and are usually on them an hour ahead of time to thoroughly examine them. These engines make 3,000 miles per month in freight service, which is considered good for this type.

E. F. Boyle (Sunset Central):—No difficulty is found on the Sunset Central in operating the pool system. Every time an engine reaches a terminal it is given a thorough inspection and the repairs are promptly made. A district of 1,190 miles is operated with three engines with no difficulty whatsoever. Oil engines are used on this road.

F. R. McShane (C. C. C. & St. L.):—The operation of the pooled system can be handled with economy and satisfactorily if the terminal repairs to locomotives are properly made. No matter whether it is the general practice to assign engines or not, it is not possible to keep them assigned at all times. In a special rush of business there are times when they must be pooled.

B. J. Feency (I. C.):—Four years ago there was a bad congestion on the Illinois Central which was then operating its locomotives under the pooled system. The general manager ordered that the engines be assigned to specific crews against the judgment of many of the road foremen on the road at that time. This was done and two weeks afterward the engine delays were materially decreased. The fuel consumption was decreased and, as it proved later, the cost of maintenance was less.

F. P. Roesch (E. P. & S. W.):—The pool system can be operated satisfactorily if the engines are properly maintained. This requires an organization and a system to do the work properly. With the handling of the army at the border, where we have heavy grades, we had very little difficulty. Locomotives would run through divisions 600 miles long with very few engine failures. We find our cost of handling locomotives at terminals varying between \$1.33 and \$4.58.

Other speakers on the subject strongly recommended the assignment of power, and numerous interesting cases were mentioned wherein it had been found to be the most desirable thing to do. In one case, on the Baltimore & Ohio, where the power had been assigned, the failures were very small, varying between two and three a month, and the engines made 119 to 121 miles per day. Later when these engines were pooled the failures increased from three to 29, and only 89 to 103 miles per engine per day were made. Under the assigned system the engines were in first class condition while under the pooled system they were not. It was also claimed that the fireman could learn to handle a specific engine and thus make a better fuel performance than if he were given a different engine every day. Various other records were shown wherein the mileage between shoppings and the daily mileage were less under the pooled system than under the assigned system and where more ton miles were hauled.

P. O. Wood (Committee chairman):—The assigning or the pooling of engines would depend a great deal upon local conditions. In either case the engines should be properly maintained. The locomotive inspector is a most valuable man but he can be made absolutely worthless by disregarding his report, and by not making the repairs he recommends. On the Frisco under the pooled system 22,000 miles per engine failure are made on freight engines.

#### OTHER BUSINESS

W. H. Corbett, (M. C.), presented his report of attendance at the Master Mechanics' Association last June, and also read the paper he was requested to prepare for that association at its convention.

The Committee on Constitution and By-Laws changed the articles requiring that all papers to be presented at the annual convention should be in the hands of the secretary ninety days before the convention. It was also voted that the executive committee confer with representatives of the Air Brake Association and the International Railway Fuel Association regarding their consolidation with the Traveling Engineers' Association.

During the closing exercises W. O. Thompson, secretary of the association since its inception and who was largely responsible for its organization, was presented with a past president's badge, being made an honorary past presidentship. In acknowledging this gift Mr. Thompson stated that since the association has been organized 900 members have served on committees, 181 subjects have been considered and

that the average attendance for the past 15 years has been 300. Professor Louis E. Endsley, of the University of Pittsburgh, was made an honorary member of the association.

The following officers were elected for the ensuing year: President, B. J. Feeney, Ill. Cent.; first vice-president, H. F. Henson, N. & W.; second vice-president, W. L. Robinson, B. & O.; third vice-president, G. A. Kell, G. T.; fourth vice-president, W. E. Preston, Southern; fifth vice-president, L. R. Pyle, M. St. P. & S. S. M.; treasurer, David Meadows, M. C. The following new members were elected to the executive committee: J. Keller, L. V.; J. P. Hurley, Wabash; P. F. Roesch, E. P. & S. W.; E. Hartenstein, C. & A.

Chicago received the vote for the next convention.

### PREPAREDNESS AND THE RAILWAYS\*

There is a degree of preparedness for national defense the value of which appears to be recognized by all except an eloquent minority. But some of those who clamor loudest for those outward and visible signs of readiness, a strong army and navy, neglect consideration of equally essential fundamental preparations. An army and navy, unsupported by adequate transportation facilities, are merely a bluff.

In the event of war, the transportation of heavy guns is an important factor. The extent of the special transportation facilities absolutely required is probably but little appreciated. The factories where the guns are made and repaired must be located at a distance from the place where their use is required. They must be transported to the firing line. The new 16-in. gun now being developed by the Ordnance Department of the United States army is looked upon with special favor by military authorities. It requires a special car for its transportation. The government does not own such a car, but has obtained the use of one through the courtesy of the Bethlehem Steel Company. The 14-in. gun is transported on a 200,000-lb. flat car with an ordinary flat car serving as a trailer. Only two or three roads, according to the Official Railway Equipment Register for May, 1916, have cars of any class approaching this capacity. The Norfolk & Western has 750 gondolas of 180,000 lb. capacity. The Pennsylvania has about 120 flat cars of 150,000 lb. capacity. Most roads have none over 100,000 lb. capacity.

Some of the requirements in the direction of special rolling-stock equipment are indicated by the weight and dimensions of certain of the larger guns constructed by the United States government for coast defense and general service. These are as follows, on the authority of Lt. Col. Hoffer:

Caliber	Weight	Length	Width
12 in.	132,000 lb.	42 ft.	66.2 in.
14 in.	139,000 lb.	48 ft. 3 in.	66.7 in.
16 in.	284,000 lb.	49 ft. 3 in.	90.5 in.
†16 in.	367,000 lb.	67 ft. 2 in.	88.0 in.

†Figures relating to the new 16-in. gun are taken from the design, the gun itself not having been built at the date of Lt. Col. Hoffer's letter.

All 16-in. guns, therefore, will require for their transportation cars of a capacity of which none have been built except one in possession of the Bethlehem Steel Company. There is only a limited number of cars capable of being used for the transportation of 14-in. guns.

The significance of this lack of equipment can only be brought home by a consideration of the requirements of service in view of the short life of heavy guns under firing conditions. Under ordinarily favorable circumstances in a continuous action, offensive or defensive, from 8 to 10 guns per day would be required to give the service of one. That is, replacement of each gun—the removal of the exhausted gun and the placing of a substitute—would have to go on at the rate of one for every two and a half or three hours. And for this service between each point of action and the distant factory, the special equipment would be required. Contrary

\*Abstract of a paper presented by W. L. Park, vice-president, Illinois Central, at the September meeting of the Western Railway Club.

to the general supposition that a position strongly fortified with heavy guns can be supported by the use of those guns until the determination of the action, the foregoing statements indicate how short-lived a fortification must be without the requisite transportation facilities.

Adequate facilities are also essential for the transportation of troops and ammunition. Henry Maxim, inventor of explosives, is quoted in a recent book, "War's New Weapons," as saying that "within a circle of 160 miles around Peekskill, N. Y., as the center, will be found 90 per cent of the arms and ammunition works, military stores, smokeless powder works, torpedo and torpedo boat works of the country."

It is about 2,500 miles in an air line from this center to the Pacific Coast and about 1,600 miles to the Rio Grande. Transportation routes are much longer. Either transportation facilities must be adequate to annihilate these distances without delay in the delivery of munitions to the various points where they may be of vital importance, or plants for the manufacture of such munitions should be located at points far in the interior.

The first general requirement is a sufficiency of equipment not only for the conveyance of troops and of ordinary supplies, but of such rolling stock as is adapted for the transport in quantity of the heavier items of military outfitting, in addition to that which is necessary to carry on ordinary transportation service. The ordinary demands of transportation service cannot be left out of the account. In many respects the supply of rolling stock equipment fails to be adequate in times of peace. The special demands created by a condition of warfare would magnify this deficiency, at least locally. What would amount to a considerable surplus of equipment under ordinary traffic conditions would be quickly wiped out if the railways should be called upon to perform their essential functions as a part of a system of defense. To move a field army would require: 2,115 passenger cars; 385 baggage cars; 1,055 box cars; 1,899 stock cars; 775 flat cars; total, 6,229 cars, which make about 366 trains, and require this number of locomotives.

Of fully as great importance as an adequate supply of equipment is the requirement that all roadway and track facilities be put in proper condition. This point may be specially emphasized in view of a too-well-founded impression that on many lines during the last two or three years of business depression maintenance of way has been somewhat neglected.

But the railways cannot be depended upon even to the limit of their present efficiency unless means can be provided for their protection against defection within their own organization. A short time ago, when trouble from any one of three or more foreign sources was threatening, four of the most powerful organizations of labor concerned in railway operation threatened to tie up every mile of railway in the United States unless certain extreme demands for increased wages were granted. These employees know, because they are part of it, the vital function the railways perform in the commercial prosperity of the country. They know the difficulties through which the railway industry has been passing in the last few years and they know that it is impossible for the railways to meet their demands except there shall be granted measures of relief which must come, if at all, from sources entirely beyond the control of the railways themselves. They know, also, that at a crisis in national affairs such as may materialize at any moment, a strike by operating railway employees would be an act of treachery to the nation to which they belong of which there is no parallel in the civil or military history of any country.

In case of actual hostilities all employees should be placed under military control, and any failure to stay at work and perform their duties should be made punishable just as the failure of a soldier to perform his duties is punishable.

# MODERN BRITISH GOODS LOCOMOTIVES

The 2-8-0 and 4-6-0 Types Are the Largest Employed; 0-8-0 and 2-6-0 Types Still Frequently Used

BY E. C. POULTNEY, M. Am. Soc. M. E.; A. M. I. M. E.

FOR many years the main line goods and mineral traffic of British railways was conducted entirely by engines of the 0-6-0 or six-coupled type, having wheels about 4 ft. 6 in. or 5 ft. in diameter, according to the class of traffic they were required to handle. Some railways have recently built superheated engines of this type and when thus equipped, engines of considerable power can be obtained. However, an actual heating surface of 1,500 sq. ft. to 1,600 sq. ft. and in the

extension of the boiler heating surfaces is obtainable, making it possible to realize a greater percentage of the available tractive effort and higher sustained speeds. Recently, the 0-8-0 type has been further developed to the 2-8-0 type, the additional carrying wheels enabling an increase in boiler capacity to be obtained. A study of the table of dimensions will reveal the fact that in some cases the total weight of 0-8-0 and 2-8-0 types are very similar. This is, of course,



London & North Western Superheated Goods Locomotive

case of superheated engines, an equivalent heating surface of 1,700 sq. ft. marks the limit in the boiler capacity obtainable with engines of this type, owing to the allowable weight that can be placed on three axles.

Demands for increased hauling power have led to the development of the 0-6-0 engine in two directions. By the addition of another coupled axle, the eight-coupled or 0-8-0 type is attained, thus increasing the weight available for adhesion and rendering an increase in tractive effort obtain-

due to the fact that the allowable weight per axle varies on different roads.

Superheating is now in general use and excellent results are being obtained. The application of a superheater is in reality equal to an extension of the evaporative heating surfaces and any addition to heating surface is attended by either a decrease in fuel consumption for the same power or by an increase in power for the same fuel consumption. In this connection, it is interesting to draw attention to the



Great Northern Eight-Coupled Goods Locomotive

able and at the same time making it possible, in the case of engines using saturated steam, to provide boiler power up to about 2,000 sq. ft. of heating surface, or in the case of superheater engines, an equivalent heating surface of 2,300 sq. ft. The other direction in which development has taken place is by adding either a leading "pony" or a four-wheeler truck or "bogie" and thus obtaining the 2-6-0 and 4-6-0 types respectively. The advantage of both is, in fact, that an

extension of the boiler heating surfaces is obtainable, making it possible to realize a greater percentage of the available tractive effort and higher sustained speeds. Recently, the 0-8-0 type has been further developed to the 2-8-0 type, the additional carrying wheels enabling an increase in boiler capacity to be obtained. A study of the table of dimensions will reveal the fact that in some cases the total weight of 0-8-0 and 2-8-0 types are very similar. This is, of course,

ing a gain of 14.8 per cent in boiler power. The efficiency of superheated engines is, however, more readily affected by the kind of service on which the engine so fitted is employed, than is the case with engines using saturated steam. This is due to the fact that considerable loss in superheat is experienced if frequent stops are made, for reasons easily understood.

The abolishing of dampers or the fitting of improved means of operating them has, however, improved the action of superheated engines on intermittent service and made it possible to realize results comparing favorably with engines run under the best conditions, namely on long continuous runs such as obtain in express passenger or through goods service. The Midland Railway have introduced an ingenious arrangement for operating the damper gear in connection with the superheater equipment they use, the device being arranged so that the dampers may automatically open or close according to whether the "regulator" or throttle valve is open or shut, or they may remain permanently open independent of the position of the regulator. Under the latter conditions, however, the arrangement is such that should the steam blower be put on, the dampers automatically close and open again when the blower is stopped. The first mentioned conditions are used when working trains making long continuous runs and the second when operating trains which make frequent stops. This device makes superheated engines efficient on all kinds of service, the loss in superheat being reduced to a minimum when the engines are operating trains making frequent stops.

Another idea designed with the object of reducing the loss of superheat is a special form of header in use on the Hull & Barnsley on goods locomotives. The design of the header, in which is incorporated the regulator valve, is such that boiler steam is always in the superheater elements and header, the regulator valve simply controlling the supply of steam between the header and the cylinders; thus the pressure of steam in the superheater at all times prevents the elements from becoming damaged through overheating. Some designers use a by-pass arrangement to connect the two ends of the cylinders when the engine is running without steam in order to do away with the pumping action of the pistons; this is, however, by no means general, most designers simply fitting automatic air valves to the steam chests. The Midland use a by-pass pipe connecting the ends of the cylinders and fitted in the centre of its length with a double beat valve operated by a small steam piston mounted on the valve stem. The underside of this small piston is connected by means of a small pipe with the steam supply to the main cylinders so that when steam is on the valves are kept on their seats, thus cutting off connection between the ends of the cylinders, and when steam is shut off, the valves simply fall from their seats thus establishing connection between the ends of the cylinders.

Piston slide valves giving inside admission are used as a rule where superheated steam is employed and Walschaert valve motion is coming into favor on the Great Northern, while the London & North Western and the Lancashire & Yorkshire both use Joy gear. The usual form of valve motion on other lines is the ordinary link motion and the wheel and screw is generally favored for operating the reversing gear. Engines of the 2-6-0 and 4-6-0 types are usually fitted with the necessary apparatus for working the continuous brake in use on the particular railway on which they are employed. This enables the engines to run passenger trains if desired and also heavy trains of perishable goods which are composed of "fitted" stock and are run at passenger train speed. Goods and mineral trains are not as a rule equipped with any form of continuous brake and it has been the practice for many years past to fit the locomotives used entirely for goods traffic with powerful steam brakes operating on the engine and tender. This is still very general practice. Exceptions are, however, to be found, in which cases the automatic vacuum or Westinghouse brake

DIMENSIONS AND PROPORTIONS OF MODERN BRITISH LOCOMOTIVES FOR GOODS AND MINERAL TRAFFIC

Railway	London & No. Western		Great Northern		Great Central		Great Western		Lancashire & Yorkshire		Midland		Glasgow & So. Westn		North Eastern		Somerset & Dorset		Hull & Barnsley		Caledonian		London & So. Western			
	Type	Cylinders, number	Type	Cylinders, number	Type	Cylinders, number	Type	Cylinders, number	Type	Cylinders, number	Type	Cylinders, number	Type	Cylinders, number	Type	Cylinders, number	Type	Cylinders, number	Type	Cylinders, number	Type	Cylinders, number	Type	Cylinders, number		
Coupled wheels, diameter	1 ft 5 1/2 in.	5 ft 3 in.	4 ft 8 in.	5 ft 8 in.	4 ft 8 in.	5 ft 8 in.	4 ft 7 1/2 in.	5 ft 8 in.	4 ft 6 in.	4 ft 6 in.	5 ft 3 in.	5 ft 4 ft.	7 1/4 in.	4 ft 7 1/2 in.	5 ft 9 in.	5 ft 9 in.	5 ft 9 in.	5 ft 9 in.	5 ft 9 in.	5 ft 9 in.	5 ft 9 in.	5 ft 9 in.	5 ft 9 in.	5 ft 9 in.	5 ft 9 in.	
Boiler pressure	160	175	170	170	170	180	180	200	180	180	160	180	160	190	170	170	170	170	170	170	170	170	170	170	180	
Heating surface, tubes, sq. ft.	1,635.7	1,840.5	1,922	1,523	1,538	2,210	1,686.0	1,349.0	1,767.0	1,767.0	1,045	1,344	1,226.2	1,170	968	1,439	1,439	1,439	1,439	1,439	1,439	1,439	1,439	1,439	1,759	
Heating surface, firebox, sq. ft.	146.7	144.3	162	144	153	167	155.0	128.7	147.0	147.0	125	147	144.0	151	132	128	128	128	128	128	128	128	128	128	167	
Heating surface, total, sq. ft.	1,772.4	1,984.8	2,084	1,667	1,691	2,377	1,841	1,477.7	1,914	1,914	1,170	1,491	1,370.2	1,321	1,100	1,567	1,567	1,567	1,567	1,567	1,567	1,567	1,567	1,567	1,926	
Heating surface, superheater, sq. ft.	378.6	...	570	403	318	440	287.0	212.5	...	...	313	211	544.8	360	217	403	403	403	403	403	403	403	403	403	394	
Total equivalent heating surface	2,330.0	...	2,939	2,204	2,168	3,037	2,371.0	1,846.4	...	...	1,639	1,807	2,187	1,861	1,425	2,161	2,161	2,161	2,161	2,161	2,161	2,161	2,161	2,161	2,517	
Grate area, sq. ft.	23.6	25.0	26.0	24	26.0	26	20.5	20.5	23.05	23.05	21.1	26.25	23.0	28.4	19.6	21.0	21.0	21.0	21.0	21.0	21.0	21.0	21.0	21.0	30.0	
Tractive effort, lb.†	25,700	22,196	31,750	22,600	28,318	35,200	22,220	25,763	22,490	22,490	22,490	23,700	24,600	36,360	22,600	20,600	20,600	20,600	20,600	20,600	20,600	20,600	20,600	20,600	26,200	
Cylinder volume per mile, cu. ft.	6,900	6,705	8,070	5,630	7,490	6,540	6,866	5,530	6,866	6,866	6,070	6,050	7,420	7,997	5,820	5,660	5,660	5,660	5,660	5,660	5,660	5,660	5,660	5,660	6,160	
Weight on coupled axles, lb.	134,400	141,120	170,688	142,576	161,280	...	152,996	141,120	137,340	137,340	109,984	122,784	147,616	135,930	114,672	153,440	153,440	153,440	153,440	153,440	153,440	153,440	153,440	153,440	131,264	
Weight of engine only, in working trim, lb.	134,400	141,120	170,688	142,576	161,280	...	152,996	141,120	137,340	137,340	109,984	122,784	147,616	135,930	114,672	153,440	153,440	153,440	153,440	153,440	153,440	153,440	153,440	153,440	131,264	
Superheating surface, per cent of the total heating surface.	17.6	...	21.1	19.3	15.3	15.6	13.4	12.5	...	...	21.1	12.38	28.6	21.4	16.5	20.6	20.6	20.6	20.6	20.6	20.6	20.6	20.6	20.6	20.6	12.8
Cylinder volume per mile ÷ heating surface (actual)†	3.21	3.38	3.04	2.74	3.72	2.28	3.18	3.27	3.51	3.51	4.1	3.55	3.87	4.71	4.23	2.89	2.89	2.89	2.89	2.89	2.89	2.89	2.89	2.89	2.89	2.66
Cylinder volume per mile ÷ equivalent heating surface*	2.95	...	2.74	2.58	3.45	2.15	2.86	3.0	...	...	3.71	3.35	3.39	4.29	4.07	2.62	2.62	2.62	2.62	2.62	2.62	2.62	2.62	2.62	2.62	2.43
(Cylinder vol. per mile ÷ grate area.	292	268	299	238	388	250	247	319	297	297	288	231	322	281	297	270	270	270	270	270	270	270	270	270	270	205
Weight on coupled axles ÷ tractive effort	5.16	4.46	5.73	5.28	...	4.4	3.9	5.4	5.35	5.35	4.85	5.17	6.0	3.36	5.07	5.6	5.6	5.6	5.6	5.6	5.6	5.6	5.6	5.6	5.0	
Total engine weight ÷ heating surface (actual)†	61.6	71.2	64.3	67.7	80.2	...	71.7	83.5	71.7	71.7	73.5	77.8	77.0	80.3	82.0	78.3	78.3	78.3	78.3	78.3	78.3	78.3	78.3	78.3	78.3	76.6
Total engine weight ÷ equivalent heating surface	56.6	...	58.1	64.0	70.6	...	64.4	76.5	...	...	66.5	74.2	67.5	72.5	80.04	71.0	71.0	71.0	71.0	71.0	71.0	71.0	71.0	71.0	71.0	70.3
Weight on coupled axles, per cent of the total engine weight	100.0	70.0	88.0	84.0	...	...	90.06	85.0	100.0	100.0	100.0	87.2	100.0	93.0	100.0	75.5	75.5	75.5	75.5	75.5	75.5	75.5	75.5	75.5	75.5	73.8

\* The equivalent heating surface is estimated by adding a value equal to 1.5 times the superheating surface to the total evaporative surface.  
† Actual heating surface = total evaporating heating surface + the superheating surface.



are used in lieu of a steam brake, or sometimes a steam brake is used which is automatically brought into action when the vacuum brake is applied on the trains or independently in the case of trains composed of "non fitted" stock. Tenders are in general interchangeable with those used with other classes of engines on the same railway.

The first eight-coupled engine in Britain for main line service was built at Crewe in 1892 by the late F. W. Webb, for working heavy coal trains on the London & North Western. This engine had inside cylinders 19½ in. by 24 in., coupled wheels 4 ft. 5 in. diameter, and had a boiler carrying

high-pressure cylinders were 16 in. by 24 in. and the two low-pressure cylinders placed between the frames were 20½ in. by 24 in. Piston slide valves were introduced to distribute the steam in the high-pressure cylinders and Joy valve motion applied to the inside gear worked the flat valves of the low-pressure cylinders direct and the high-pressure valves through rocking levers, two sets of valve gear thus operating the four valves. Adjacent cranks on each side of the engine were on opposite centers, each pair being at 90 deg. The weight of the engine only, in working trim, was 119,840 lb. Large numbers of these engines were built;



Great Northern Six-Coupled Goods Locomotive

a steam pressure of 160 lb. which contained 1,245 sq. ft. of heating surface. The total engine weight in working order was 104,792 lb. This engine was followed in 1893 by another similar in design but compounded on F. W. Webb's three-cylinder system. These two engines were run in competition with the result that subsequent engines were all compounds. The compound engines had two outside high-pressure cylinders 15 in. by 24 in. and one inside low-pressure cylinder 30 in. by 24 in., all driving on to the second coupled axle. The high-pressure crank pins were at 90 deg. with each other and the central crank made 135 deg. with each of the high-pressure cranks. The boiler contained 1,489 sq. ft. of heating surface, the increase being in the tube surface. The

some were provided with two-wheeled pony trucks at the leading end, thus becoming 2-8-0 or Consolidation type engines, the first in Britain. The coupled wheels of each class were the same diameter and had cast iron centers, a practice unique in main line service, and this material is still used for 0-8-0 engines built at Crewe. All the compound engines have now been converted into simple engines; in the case of the four-cylinder engines the low-pressure cylinders have been retained as simple expansion cylinders and the working steam pressure reduced from 200 lb. to 165 lb. The engine illustrated is one of a new type designed by C. J. Bowen-Cooke, the chief mechanical engineer. It is equipped with a Schmidt superheater and when compared with similar engines



Great Central Six-Coupled Express Goods Engine

coupled wheels were 4 ft. 5 in. diameter and the engine weighed 110,320 lb. in working trim. In these engines, considerable numbers of which were built, the steam pressure was increased to 175 lb.

Some years later after F. W. Webb had commenced to build his four-cylinder compound express engines, he applied his four-cylinder system to the eight-coupled goods engines and the first engine turned out was built at Crewe in 1901. These were similar to the three-cylinder engines, but the boilers were larger, the total heating surface being increased to 1,753 sq. ft., and the steam pressure was raised to 200 lb. The

using saturated steam doing equal work, this type has shown a saving of 25 per cent in coal consumption. The engines have inside cylinders and piston valves worked by Joy motion. The wheels are 4 ft. 5½ in. diameter with new tires. A steam brake is fitted which operates on the engine and tender. The tender is of standard design and has capacity for 7 tons of coal and 3,000 gallons of water. It is fitted with a water scoop and weighs 83,000 lb. loaded.

The 4-6-0 engines, particulars of which are given in the table of dimensions, were built for main line fast goods traffic on the London & North Western from the designs of the late

G. Whale, when chief mechanical engineer. In design these engines resemble closely Mr. Whale's 4-6-0 express engines introduced in 1906, the main difference being the diameter of the coupled wheels which in the goods engine is 5 ft. 3 in. diameter, and in the case of the passenger engine, 6 ft. 3 in. The cylinders are inside, driving on to the leading coupled axle, and the distribution of steam is effected by flat semi-balanced valves working in steam chests on the top of the cylinders and operated by Joy valve gear. The leading end of the engine is carried on a four-wheeled bogie. The London & North Western bogie differs from those most used in that the lateral movement takes place in a radial path similar to a radial axle box. This bogie was introduced by Mr. Webb when he designed his four-cylinder compound express engines which were the first engines built at Crewe to have four-wheeled bogies. The crank axles are built up and the crank webs are extended in order to form balance weights. Apparatus for working the automatic vacuum brake is fitted and a steam brake operates on the engine and tender, which is of the standard type. Previous to the introduction of these engines, the express goods service on the London & North Western was largely worked by Mr. Webb's 18-in. 0-6-0 goods engines having 5 ft. wheels. These engines are of historic interest inasmuch as they were the first locomotives ever fitted with Joy system of valve motion and when first introduced in 1880 they attracted considerable attention.

The Lancashire & Yorkshire employ eight coupled engines for hauling the heavy goods traffic they have to contend with on a road which is difficult to work, and at present four classes are in service: three having simple expansion cylinders and one compound having four cylinders. The simple engines differ from each other in the design and size of the different boilers used. The first engines put into service had inside cylinders 20 in. by 26 in. and boilers with Belpair fire boxes providing 1,914 sq. ft. of heating surface. They weighed in working order 137,752 lb. These engines were followed by a number of similar locomotives having exactly the same sized cylinders and wheels, but they were fitted with a new type of boiler having a cylindrical inside

The compound engines have the same size Belpair boiler working at the same steam pressure as the simple expansion goods engines. Four cylinders are used, two high-pressure outside the frames driving on the third coupled axle and two low-pressure inside driving on to the second axle, placed transversely in line with the outside cylinders. The inside and outside cranks on each side of the engine are on opposite centers and each pair makes an angle of 90 deg. with the other. Flat semi-balanced valves distribute the steam in the low-pressure cylinders and the low-pressure exhaust takes place through the backs of the valves directly into the blast pipe; thus a free exhaust is attained. Piston valves are used for the high-pressure cylinders. Joy valve gear is used and is applied to the inside motion, connection being made to the high-pressure valves by rocking levers. The arrangement is such that adjacent valves on each side of the engine travel in the same direction, an arrangement made necessary because the piston valves have inside admission. The piston valves used have been specially designed to eliminate excessive compression in the high-pressure cylinders due to the engine being "linked up." The piston valve packing rings are fitted with six small valves the construction of which is such that the pressure in the receiver holds them on their seats against the pressure in the cylinder, providing the latter does not rise above the working pressure. This is effected by designing the valves in such a way that the area exposed to the receiver pressure is greater than that exposed to the pressure in the high-pressure cylinders. Starting is effected by supplying steam direct from the boiler to the low-pressure steam chests. This is effected by two sliding valves working in a small rectangular valve box cast integral with the low-pressure cylinders and valve chests. These valves work over two ports connected respectively with the right and left low-pressure steam chests, a pipe conveying steam from the main steam pipe to the small valve chest. The starting valves are controlled by the position of the reversing gear, being connected to a lever on the reversing shaft. On the main regulator being opened steam is admitted to the low-pressure and high-pressure steam chests at the same time, the high-pressure



Superheated Goods Locomotive, North Eastern Railway

and outside fire box, the inside box being corrugated and made of steel, except the tube sheet which is made of copper. These boilers have 1,890 sq. ft. of heating surface and the weight in working order, engine only, is 129,680 lb.

The next engines to be built were the compounds already mentioned. G. Hughes, the locomotive engineer, decided to apply the compound principle to goods engines rather than passenger locomotives, his contention being that they are more suitable for compounding as the usual cut-off is much later in simple expansion goods engines than in simple expansion passenger engines, also the piston speeds attained are very much less than those realized in express engines, thus making it more possible to effect a saving in steam consumption by a reduction of the losses due to cylinder condensation as well as by increasing the number of times the steam is expanded.

pistons by that means being placed in equilibrium, and starting is effected by the low-pressure pistons only. When, however, the engine is "linked up" the small valve covers the ports leading to the low-pressure valve chests and the engine is compounded. This device is very simple and is so arranged that the low-pressure cylinders can only be supplied with steam direct from the main steam pipe when the engine is in either full forward or full back gear.

The two classes of engines, particulars of which are given in the table of dimensions, have been the subject of exhaustive tests during which 11 simple engines and 11 compound engines ran 472,000 and 442,000 engine miles respectively, the percentage of train miles being in the case of the simple engine 63.6 and in the case of the compound 68.3, the average loads behind the tender being 465 tons. After making

deduction of  $1\frac{1}{2}$  cwt. of coal per hour for fuel used during detentions, the results showed that the coal consumption of the compound was .185 lb. per ton mile against .205 used by the simple engine. A very complete statement as to the working of these and of superheated engines on the Lancashire & Yorkshire will be found in the transactions of the Institute of Mechanical Engineers for 1910.

Latterly some large simple expansion superheated engines have been put into service, which, in general, are similar to the earlier simple engines. They have, however, considerably larger boilers having a total evaporative heating surface of 1,963 sq. ft. and superheaters giving 396 sq. ft. of heating surface, the whole representing a total equivalent heating surface of 2,557 sq. ft. The cylinders are between the frames and are  $21\frac{1}{2}$  in. by 26 in. and the steam pressure is 180 lb.

signed by the locomotive engineer, H. N. Gresley, called the twin-tube superheater. Two headers are used, one above in the usual position for saturated steam and another lower in the smoke box for the superheated steam, the two being connected by the superheating elements. Each element has four lengths of tube, but instead of all four lengths of tube being in one flue tube, as is the case in the Schmidt system, two lengths, that is one loop, are in one flue and the other two in the flue immediately below. The claims made for this arrangement are that smaller flue tubes may be used, thus the bridge pieces in the tube sheets are wider, also all elements are interchangeable and each can be taken out without disturbing any of the others, further, compared with a Schmidt superheater of the same amount of heating surface, this superheater permits an increase in the evaporative surface of

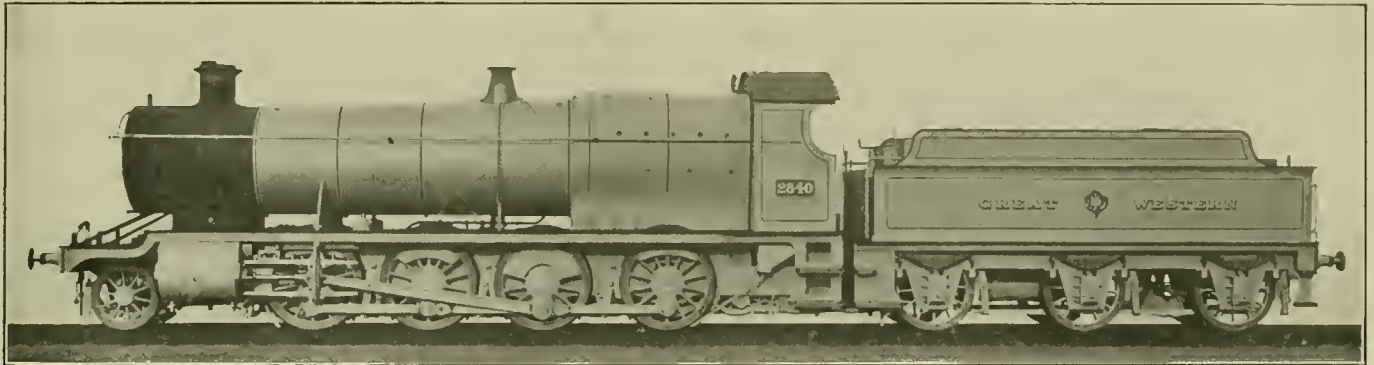

Great Western Eight-Coupled Goods Locomotive

The eight-coupled wheels are 4 ft. 6 in. diameter and in common with the other Lancashire & Yorkshire engines, are fitted with Joy valve motion. All the four classes of eight-coupled engines are accompanied by eight-wheel tenders but the wheels are not in bogie frames. These tenders have capacity for 3,600 gallons of water and 5 tons of coal. The vacuum brake is fitted to the engines and tenders.

The heavy coal traffic on the Great Northern has been conducted for some time by engines of the 0-8-0 type, the first design introduced having inside cylinders  $19\frac{3}{4}$  in. by 24 in. with flat semi-balanced valves working in steam chests on the top of the cylinders and operated by the ordinary link motion through rockers. The boilers have 1,438 sq. ft. of heating surface and the area of the grate is 24.5 sq. ft. The working steam pressure is 170 lb. The coupled wheels are 4 ft. 8 in. diameter. Recently, some of these engines have been rebuilt and equipped with Schmidt superheaters.

The latest type of engine introduced for heavy main line coal and other traffic is of the 2-8-0 type, the additional wheels being made necessary by the increased weight of the engine due to the large boiler. The cylinders are in this case outside the frames and piston valves worked by Walschaert motion are used. Some of these engines are fitted with steam pumps for supplying the boiler feed water and also with feed water heaters. These engines are remarkable for their boiler capacity, the amount of heating surface allowed when compared with the cylinder capacity being very generous.

The 2-6-0 engine illustrated is a development of a smaller class of the same type introduced in 1912 having boilers fitted with superheaters and containing a total heating surface of 1,420 sq. ft. In other respects the two classes are very similar but the present engines are more powerful, by reason of the fact that they have a total heating surface of 2,080 sq. ft. The pony trucks of the 2-8-0 and 2-6-0 types have been designed to equalize the weight when passing round curves, this being obtained by top and bottom bolsters each carried on swing links.

The Great Northern was one of the first railways to fit superheaters, the type used being the Schmidt. Recently, however, a new type of flue tube superheater has been de-

signed by the locomotive engineer, H. N. Gresley, called the twin-tube superheater. Two headers are used, one above in the usual position for saturated steam and another lower in the smoke box for the superheated steam, the two being connected by the superheating elements. Each element has four lengths of tube, but instead of all four lengths of tube being in one flue tube, as is the case in the Schmidt system, two lengths, that is one loop, are in one flue and the other two in the flue immediately below. The claims made for this arrangement are that smaller flue tubes may be used, thus the bridge pieces in the tube sheets are wider, also all elements are interchangeable and each can be taken out without disturbing any of the others, further, compared with a Schmidt superheater of the same amount of heating surface, this superheater permits an increase in the evaporative surface of

10 per cent. A large air valve is fitted to the saturated steam header and when steam is shut off, this valve opens and allows air to enter the elements, thus preventing them from becoming damaged by overheating.

The Great Central Railway use 2-8-0 engines for hauling the heaviest traffic they have to handle. These engines were preceded by engines of the 0-8-0 type which were introduced some years ago. The newer engines in general present no unusual features. They have outside cylinders driving on the third coupled axle, piston valves and the ordinary form of link motion. The boilers have Belpair fire boxes and flue tube superheaters. The fast goods traffic is conducted by some very large 4-6-0 engines which are certainly the most powerful of their type in the country. The boilers, cylinders and motion are the same as used in the large 4-6-0 express engines introduced previously and, like all Great Central engines, are fitted with the Robinson superheater. These engines are fitted with the apparatus for working the automatic vacuum brake and a steam brake is used on the engine and tender.

The most recent class of eight coupled goods engine used on the North Eastern Railway, is illustrated by the photograph for which the writer is indebted to V. L. Raven, the chief mechanical engineer. The general design follows closely some engines of the same type introduced by W. Worsdell in 1901. The present engines are, however, fitted with larger boilers equipped with flue tube superheaters. Piston valves operated by the ordinary form of link motion are used and a steam brake is fitted to the engine and tender, the arrangement being such that one brake cylinder on the engine applies a brake block to each wheel on the engine, and to each wheel on the tender. The boiler is supported at the smoke box end by a cast saddle and it may be pointed out that this method of front end support has, of late years, found considerable favor in England. Two pop safety valves are used instead of the Ramsbottom type usually employed in British practice. The tender is of the six-wheeled type and is of considerable size, having capacity for 3,940 gallons of water and 5 tons of coal. Its weight loaded is 92,288 lb. and empty 44,800. The engines present a particularly neat

appearance in common with general North Eastern practice.

The writer is indebted to G. J. Churchward, locomotive superintendent of the Great Western Railway, for the photographs and particulars of the two Great Western engines illustrated. The 2-8-0 engine represents a class designed to conduct the heaviest main line traffic and is an engine of considerable power. The 2-6-0 engine is one of a class introduced for hauling fast goods trains, and like all modern Great Western engines, is fitted with a flue tube superheater designed by Mr. Churchward and known as the Swindon superheater. The outside cylinders of both engines have piston valves worked by the ordinary type of link motion. An automatic air valve is fitted to the steam chests and the cylinder covers are fitted with spring loaded water relief valves. Both engines are fitted with the Swindon top feed arrangement whereby the feed water is introduced into the steam space of the boiler through non-return valves fitted on the safety valve mounting, the pipes to which are well shown in the photographs. It will also be noticed that the connecting rod big ends are of the solid bush pattern, a practice universal in the case of all outside cylindered engines built at Swindon. Both engines have the standard type of six-wheel tender which carries 3,500 gallons of water and about 5 tons of coal. The automatic vacuum brake is fitted to the engine and tender and the latter is fitted with a water scoop. The Swindon type of boiler is clearly shown in the photograph which illustrates the standard No. 1 boiler as

ployed where superheated steam is used, are flat semi-balanced valves, special arrangements being made by means of oil passages drilled in the valve chest valve faces for efficiently lubricating the slide valves. These oil passages are connected by means of suitable piping to a mechanical lubricator driven from the low-pressure rocking lever at the point where it joins the valve spindle. It may here be mentioned that mechanical lubricators giving a forced oil feed to both pistons and valves is usual practice in Britain where high degree superheated steam is employed. These engines were fully illustrated in *Engineering* of July 2, 1915, and may be said to be characteristic of British practice in the design of inside cylinder 0-6-0 engines, of which large numbers are at work on all railways, though in general they are not superheated.

In 1914 some powerful outside cylindered 4-6-0 type engines were put into service on the London & South Western for fast goods and heavy passenger traffic, and are what are generally known as "mixed traffic engines." At first, 10 of these engines were built, two using saturated and eight, superheated steam; four of the latter having Schmidt superheaters and four having the Robinson equipment. In other respects, the engines are identical. The dimensions given in the table give particulars of the saturated steam engines in comparison with those fitted with the Schmidt superheater. Walschaert valve motion is used and the valves are of the piston type. The boilers of these engines are of the usual

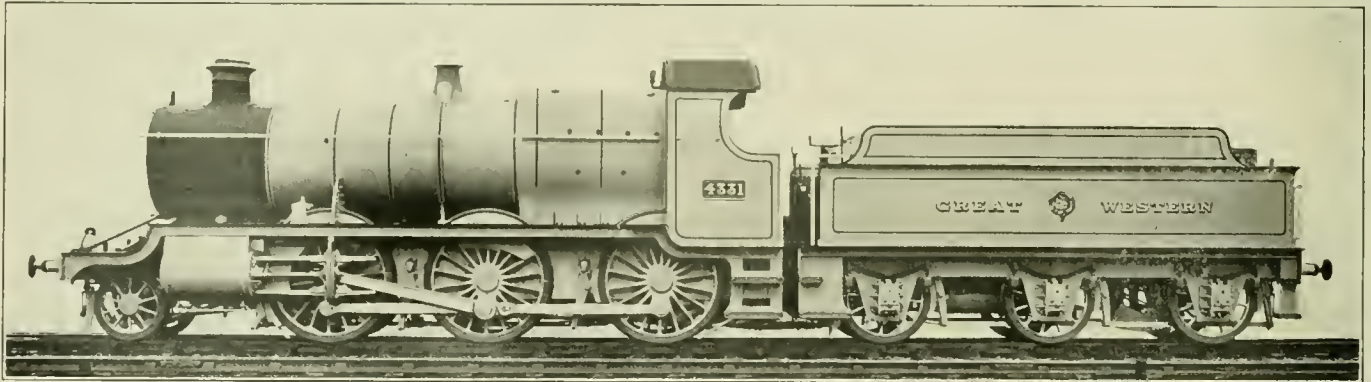

Express Goods Locomotive, Great Western

fitted to the 4-6-0 express engines and the 2-8-0 locomotives. It will be seen that the boilers are without steam domes, the steam being collected by a long pipe running through the steam space in the boiler barrel and the regulator valve is placed in the smoke box above the superheater header. Another feature of Great Western practice is the method of supporting the boiler at the smoke box end, this being done by means of a cast saddle similar to American practice. The expansion bracket supporting the fire box which slides on the top of the frame plates is clearly shown in the photograph.

The 2-8-0 engine, particulars of which are tabulated, has been put into service on the Somerset & Dorset for working heavy trains over a difficult road. The engines were built at the Derby Shops of the Midland Railway from the designs of H. Fowler, locomotive engineer of the Midland, which provides the locomotive power for the Somerset & Dorset. The engines have outside cylinders and piston valves worked by Walschaert gear, and reversing by a steam gear. The boilers have Belpair fire boxes and Schmidt superheaters and Mr. Fowler's cylinder by-pass arrangement and damper control gear are fitted. The cylinders drive on the third coupled axle. A steam brake operates on the engine and tender and the pony truck wheels have brake blocks.

The Hull & Barnsley employ engines of the 0-6-0 type, dimensions of which are enumerated, on main line goods service. These engines have "inside" cylinders, the valves instead of being of the cylindrical pattern, generally em-

ployed where superheated steam is used, are flat semi-balanced valves, special arrangements being made by means of oil passages drilled in the valve chest valve faces for efficiently lubricating the slide valves. These oil passages are connected by means of suitable piping to a mechanical lubricator driven from the low-pressure rocking lever at the point where it joins the valve spindle. It may here be mentioned that mechanical lubricators giving a forced oil feed to both pistons and valves is usual practice in Britain where high degree superheated steam is employed. These engines were fully illustrated in *Engineering* of July 2, 1915, and may be said to be characteristic of British practice in the design of inside cylinder 0-6-0 engines, of which large numbers are at work on all railways, though in general they are not superheated.

In 1914 some powerful outside cylindered 4-6-0 type engines were put into service on the London & South Western for fast goods and heavy passenger traffic, and are what are generally known as "mixed traffic engines." At first, 10 of these engines were built, two using saturated and eight, superheated steam; four of the latter having Schmidt superheaters and four having the Robinson equipment. In other respects, the engines are identical. The dimensions given in the table give particulars of the saturated steam engines in comparison with those fitted with the Schmidt superheater. Walschaert valve motion is used and the valves are of the piston type. The boilers of these engines are of the usual

fitted to the 4-6-0 express engines and the 2-8-0 locomotives. It will be seen that the boilers are without steam domes, the steam being collected by a long pipe running through the steam space in the boiler barrel and the regulator valve is placed in the smoke box above the superheater header. Another feature of Great Western practice is the method of supporting the boiler at the smoke box end, this being done by means of a cast saddle similar to American practice. The expansion bracket supporting the fire box which slides on the top of the frame plates is clearly shown in the photograph.

The 2-8-0 engine, particulars of which are tabulated, has been put into service on the Somerset & Dorset for working heavy trains over a difficult road. The engines were built at the Derby Shops of the Midland Railway from the designs of H. Fowler, locomotive engineer of the Midland, which provides the locomotive power for the Somerset & Dorset. The engines have outside cylinders and piston valves worked by Walschaert gear, and reversing by a steam gear. The boilers have Belpair fire boxes and Schmidt superheaters and Mr. Fowler's cylinder by-pass arrangement and damper control gear are fitted. The cylinders drive on the third coupled axle. A steam brake operates on the engine and tender and the pony truck wheels have brake blocks.

The Hull & Barnsley employ engines of the 0-6-0 type, dimensions of which are enumerated, on main line goods service. These engines have "inside" cylinders, the valves instead of being of the cylindrical pattern, generally em-

type, having round topped fire box wrappers and the roof of the inside fire box is supported by direct stays in such a way that each stay will allow of the upward movement of the inside box. This is arranged for by suspending the stays from forgings in the form of two inverted tees joined together, the vertical members being pinned to bridge section pieces riveted round the inside of the wrapper sheet. Each double tee section has three stays—one passing through each end and one through the center between the suspension members. The stays are screwed into the inside fire-box crown and pass through the tee pieces a working fit and are held by two nuts on the top side of the tees. In this way, they take the load but allow the inside box to rise when it expands, due to the heat when steam is being raised. The end stays, that is, those close to the tube sheet and back sheet, are suspended from the pieces which support two stays each in much the same way to that shown in the *Railway Mechanical Engineer* for August, 1916, when the Great Central 4-4-0 express engines were illustrated and described.

The engines have large eight-wheeled double bogie tenders, having space for 5 tons of coal and a tank capacity of 5,200 gallons and both the engine and tender are fitted with the automatic vacuum brake. These tenders are heavy, weighing 128,800 lb. when loaded. The total weight of the engine and tender in working trim is 306,760 lb. or 136.6 English tons, being the heaviest class of engine and tender running in the country.

Just previous to his retirement, J. F. McIntosh built, at the St. Rollox Works of the Caledonian Railway, some large 4-6-0 inside cylindered engines designed for dealing with fast goods traffic. In general, these engines follow the usual neat design of Caledonian engines, but an innovation was made in the design of the cab which has side windows similar to those used on the North Eastern and to a limited extent on the Great Eastern lines. These engines are fitted with Robinson flue tube superheaters and the cylinders are between the frames and have their steam chests on the top. Piston valves are used driven by the ordinary link motion by

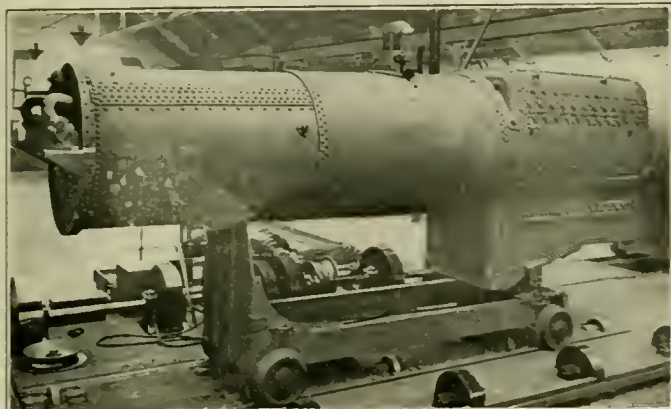

Standard Boiler for 4-6-0 and 2-8-0 Type Locomotives. Great Western

means of rockers. The leading coupled axle is the crank axle and it is of the built-up description. Steam reversing gear is fitted. The boiler is of the ordinary type, having a round topped outside fire box and direct roof stays, those in front close to the tube sheet being so arranged as to permit of the upward expansion of the inside fire box. Four 4-inch safety valves are provided in common with all Caledonian engines of the larger type. The connecting rods have big ends of an unusual pattern, the ends of which are forked and the brasses are held in position by means of a cap held by two large bolts. This type of big end has been in use some

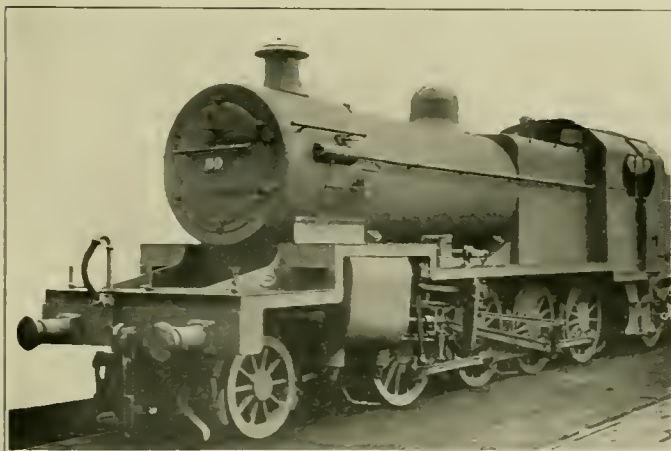

Somerset & Dorset Joint Railway Eight-Coupled Tender Goods Engine

years on the Caledonian and is also much used on the Lancashire & Yorkshire and other lines. In general, however, the strap form with gib and cotter adjustment is still much used and may safely be said to be the type most favored.

Mention should also be made of some very powerful 0-8-0 engines introduced for service on the Caledonian Railway some years ago by J. F. McIntosh when locomotive engineer. These engines have cylinders inside, 21 in. by 26 in., coupled wheels 4 ft. 6 in. diameter, and boilers working at a steam

pressure of 175 lb. containing 2,500 sq. ft. of heating surface and having a grate area of 23 sq. ft. The total weight, engine only, is 140,000 lb.

It should be noted that weights expressed in tons and capacities in gallons in this article are British measure in all instances. Engine weights have been reduced to pounds, this being in harmony with American practice.

The table gives the principal particulars relating to 18 different engines put into service during the last decade. It will be seen that a considerable range of power is covered by the engines mentioned, as the equivalent heating surfaces vary from 1,425 sq. ft. in the case of the Hull & Barnsley 0-6-0 engine, to 3,037 sq. ft. in the case of the Great Central 4-6-0 engine. The locomotives mentioned have been selected for treatment in the belief that they are representative of modern British practice and although additional engines might have been noticed, they would be, in general, similar both in design and construction to those described.

### THE KIESEL TRAIN RESISTANCE FORMULAS

BY A. J. WOOD

Assistant Professor of Mechanical Engineering, Pennsylvania State College State College, Pa.

In the report of the Committee on Train Resistance and Tonnage Rating, presented at the June, 1916, meeting of the American Railway Master Mechanics' Association, mention was made of the Kiesel method for determining the tractive effort of a locomotive. Inasmuch as a complete derivation of the formulas has not been published, the writer would give here the method and its application, as developed by Mr. Kiesel, using the same notation as outlined in "Principles of Locomotive Operation and Train Control."\*

- Let T.F. = cylinder tractive force in lb.
- D = driver diam. in in.
- d = cylinder diam. in in.
- l = cylinder stroke in in.
- H = total boiler heating surface in sq. ft.†
- P = initial cylinder pressure in lb. (considered as 10 lb. less than boiler pressure).
- K = evaporation per hour in lb. per sq. ft. of heating surface.
- w = weight of 1 cu. ft. of steam in lb. at pressure P.
- V = speed in miles per hour.

$$M = \frac{d^2 l}{D}$$

- M.E.P. = mean effective pressure.
- n = revolutions per minute of drivers.
- KH = steam per hour.

Then  $\frac{KH}{60}$  = steam per minute.

$$\frac{KH}{60 \times 4 \times n} = \frac{KH}{240n} = \text{steam per stroke} \dots \dots \dots (1)$$

$$\frac{KH}{\pi d^2 l} = w = \text{wt. cyl. full of steam} \dots \dots \dots (2)$$

$$\text{Expansion ratio} = E = \frac{(2)}{(1)} = \frac{\pi d^2 l}{1728 \times 4} w \times \frac{240n}{KH}$$

$$\text{But } n = \frac{1056 V}{\pi D}$$

$$\text{Therefore, } E = \frac{1056 d^2 l V}{D (28.8 KH) w}$$

$$\text{Or } E = \frac{110}{3} \frac{MV}{KH} w$$

$$\text{M.E.P.} = (\text{nearly}) \frac{2P}{1 + E} = \frac{2P}{1 + \frac{110}{3} \times \frac{MV}{KH} w}$$

$$\text{Since T.F.} = \text{M.E.P.} \frac{d^2 l}{D}$$

$$\text{T.F.} = \frac{2 PM}{1 + \frac{110 MV}{3 KH} w} \dots \dots \dots (3)$$

Applying equation (3) to the case of a Pennsylvania Rail-

\*By Prof. A. J. Wood. Published by the McGraw-Hill Book Company, 239 W. 39th street, New York.

†In case of superheated steam locomotive, multiply the superheater surface by 1.5 and add this to the other heating surfaces. For tubes, take external heating surface.

road H 8 b (2-8-0 type) locomotive: Assume  $K=10$ ; other values are,  $P=205-10$ ,  $d=24$ ,  $l=28$ ,  $D=62$ ,  $M=206.1$ ,  $H=3,839$ ,<sup>‡</sup>  $w=.46$  (to nearest second figure).

$$T.F. = \frac{2 \times 195 \times 260.1}{1 + \frac{110 \times 260.1 \times .46 \times V}{3 \times 10 \times 3839}} = \frac{101,440}{1 + 0.1143V}$$

To obtain the available pull behind the tender, subtract from the above the locomotive and tender resistances.

- W = total weight of train in tons.
- C = curvature in degrees.
- G = grade in per cent.
- N = number of cars.
- V = speed in miles per hour.
- R = total resistance in pounds.

The resistance on a level tangent will be,

$$R = 100N + 1.5W + 0.01V(V + 16) \sqrt{WN} \dots (4)$$

which is for the average train resistance, knowing that there is a possibility of obtaining results about 15 per cent better when car, weather and track conditions are favorable. This does not include resistances due to grades and curves. The average for curve resistance is taken as 1 lb. per ton per degree, or  $CW$ .

Grade resistance equals 20 lb. per ton for each per cent of grade, or  $20GW$ . With these terms added, the formula reads:

$$R = 100N + (1.5 + C + 20G)W + 0.01V(V + 16) \sqrt{WN} \dots (5)$$

When the locomotive and tender are included in the train, the weight of train,  $W$ , in the above must include the weight of the locomotive and tender, and the number of cars,  $N$ , as used, is to be taken as the number of cars back of the tender plus three.

The foregoing arrangement enables one to handle the whole train weight, including that of the locomotive and tender, as a unit, not only for grades and curves, but also for resistance on straight level track.

The locomotive resistances consist of machinery friction and head-end wind resistance, in addition to those mentioned in connection with train resistance.

For machinery friction,

$$R_1 = [22 + 0.15(n - 1)V]Q \dots (6)$$

- in which  $Q$  = weight on drivers in tons.
- $n$  = number of pairs of drivers.
- $V$  = speed in miles per hour.

For head end wind resistance use Professor Goss' Formula,

$$R_2 = 0.1V^2 \dots (7)$$

The locomotive and tender resistances, which are here taken the same as for the cars, are subject to the train resistance formulas and will be considered as part thereof, assuming that the engine and tender weights are equivalent to three cars of the same total weight as the engine and tender, and this must be added to equations 6 and 7.

Locomotive capacity expressed in terms of drawbar pull behind the tender is the difference between the cylinder tractive effort and the three resistances noted above.

Consider the available drawbar pull or available tractive effort of the locomotive as cylinder tractive effort, less machinery friction and head-end wind resistance,

$$A.T.F. = T.F. - R_1 - R_2$$

(For T.F. see Eq. 3.)

$$A.T.F. = \frac{2PM}{1 + \frac{110w}{3} \times \frac{MV}{KH}} - [22 + 0.15(n - 1)V]Q - 0.1V^2 \dots (8)$$

But, A. T. F. for limiting speed =  $R$ . Therefore,

$$\frac{2PM}{1 + \frac{110w}{3} \times \frac{MV}{KH}} - [22 + 0.15(n - 1)V]Q - 0.1V^2 = 100N + (1.5 + C + 20G)W + 0.01V(V + 16) \sqrt{WN} \dots (9)$$

From this it will be seen that to determine the drawbar pull of an H 8b locomotive on straight level track, the resistance to be subtracted from cylinder tractive effort is,

$$R = (22 + .15 \times 3V) 105.5 + .1V^2 + 100 \times 3 + 1.5 \times 200^* + .01V(V + 16) \sqrt{3} \times 200 = 2920 + 51.4V + .345V^2 \dots (10)$$

Hence the drawbar pull of the H 8b locomotive may be written,

$$D.B.P. = \frac{101,440}{1 + .1143V} - 2920 - 51.4V - .345V^2 \dots (11)$$

The drawbar pull at varying speeds is given in the following table:

Miles per Hour	Drawbar Pull in lb.
20	26,754
25	22,171
30	18,130
40	12,677
50	8,754

### AIR RESERVOIR SUPPORT

The usual method of supporting air reservoirs by means of cast steel brackets and straps has the disadvantage that the reservoirs are difficult to remove and replace. To provide efficient support for the reservoir and at the same time facilitate removal, a bracket composed of a base, slide and strap was designed in the mechanical engineer's office of the Union Pacific.

The malleable iron base is bolted to the underside of the running board, at or near a running board bracket, and remains permanently thereon. The slide and strap are bolted to the main reservoir, and in applying or removing

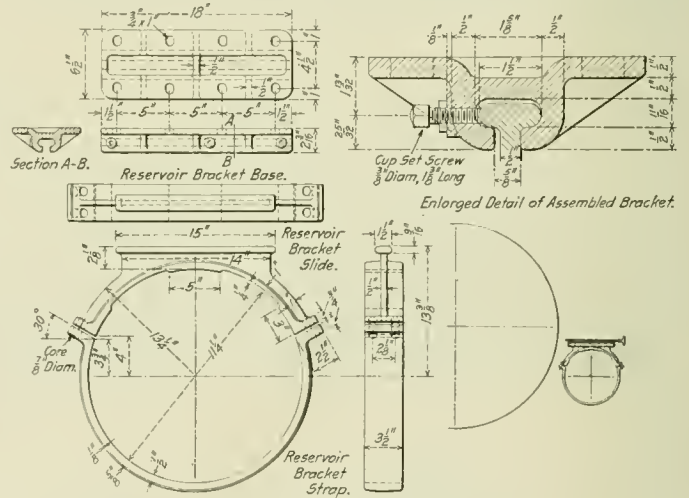

Air Reservoir Support Which Facilitates Applying and Removing the Reservoir

the reservoir it may be handled with a crane until in position to meet the slot in the base. The reservoir can then readily be slid horizontally into position and the slide secured with set screws.

The brackets may be used interchangeably on all locomotives having the same diameter of reservoir; this eliminates a large variety of bracket castings otherwise needed. They are light and comparatively cheap in cost. On locomotives having the reservoir located alongside the firebox, it is possible to move the reservoir sufficiently from the firebox to permit of inspection of staybolts, which, with the ordinary construction, would be inaccessible.

USE OF PULVERIZED PEAT IN SWEDEN.—A recent report of the Swedish Department of Commerce states that the Swedish State Railways have been experimenting with powdered peat as fuel for locomotives, and the railway directors have recommended an appropriation of £70,000 for a factory to produce sufficient powdered peat to supply all the locomotives on one of the state railway lines.—*Mechanical World*.

\*The approximate weight, in tons, of the engine and tender is 200.

‡This value is for the external heating surface, whereas the results for this locomotive as given in the book referred to are obtained by using the internal heating surface.

# THE I. C. C. HEADLIGHT HEARINGS

## Controversy Over New York Central Tests; Brotherhood Tyranny Is Used to Intimidate Witnesses

A HEARING was held at Washington on October 30 to November 3, inclusive, before the members of the Interstate Commerce Commission to enable the railroads to present additional testimony in connection with the commission's order requiring locomotives to be equipped with high-power headlights with sufficient intensity to enable persons with normal vision, in the cab of the locomotive, to see a dark object the size of a man for a distance of 1000 feet, under normal weather conditions. The commission has postponed the effective date of its order until January 1 and the hearing was called for the purpose of taking testimony regarding a series of tests made near New York on September 28, at which Commissioner Clark and the officers of the commission's boiler inspection department were present.

The hearing at once developed into a contest between the representatives of the railroads and the officers of the engineers' and firemen's brotherhoods, who challenged the fairness of the test, which they had refused to have anything to do with, and sought to prevent the introduction of further testimony. The commission, however, granted the request of the railroad attorneys, C. C. Paulding, solicitor of the New York Central, D. E. Minard, assistant general solicitor of the Erie, and S. B. Lloyd, assistant general counsel of the Pennsylvania, and ruled that each side should be allowed to present 20 witnesses before an examiner and that the evidence need not be confined to the New York test. The hearing before the commission was confined to one witness representing the carriers, one representing the employees and one called by the commission. A. G. Trumbull, assistant to the mechanical superintendent of the Erie, testified regarding the tests for the roads. A. G. Pack, assistant chief boiler inspector, was called as a witness by W. S. Carter, president of the Brotherhood of Locomotive Firemen and Enginemen, and G. E. Murray, headlight electrician, Chicago & North Western, was called as a witness for the commission.

Mr. Trumbull gave a detailed description of the tests, in which steam and electric locomotives were used, equipped with 250-watt, nitrogen bulb electric headlights furnished by the Pyle-National Company, with 9-in. by 18-in. reflectors. The headlights were adjusted by a representative of the headlight company. His testimony relative to the effect of the light from high-power headlights on the reading of signals, the observation of tail lights and markers as well as the locating of flagmen, indicated that the high-power light is confusing and dangerous under operating conditions similar to those of the tests.

In the tests to see at what distance objects on the track could be seen, a man dressed in dark blue overalls walked down the track toward the locomotive. John McManamy, assistant chief inspector of locomotive boilers, thought he saw the object at a distance of 2,389 ft., but after the distance had been measured he asked for a re-test and saw the man at a distance of 994 ft. A. G. Pack, assistant chief inspector, saw the "object" at a distance of 772 ft. and various railroad mechanical officers at distances ranging from 552 to 764 ft.

Mr. McManamy, in cross-examining the witness, sought to show that the tests were not conducted under representative conditions, and showed that the witness had had comparatively little recent experience in riding locomotives at night. Mr. Carter also questioned the manner of conducting the test, but the witness said it was conducted under actual operating conditions.

Mr. Pack testified that he had run an engine with an elec-

tric headlight for 11 years on the Colorado Springs & Cripple Creek District, before becoming connected with the commission, and had never experienced any difficulty with them. Although he admitted that his road was mostly single track with no block signals he said he ran into a station facing an electric headlight on the locomotive of another road and could see the order boards back of the light as plainly as he could if it had been an oil headlight. Mr. Pack said that he had never experienced any difficulty in seeing flags or reading signals governing the track on which he was running, with electric headlights, that he never saw any "phantom" signals or confusing indications caused by high power lights. Cross-examined by Mr. Paulding he said that he was having trouble with his eyes on the night of the test, caused by a pair of new glasses, that some steam leaking from the locomotive occasionally interfered with vision, and that the headlights used did not seem to be giving results up to standard. He said he had interviewed more than 1,000 engineers who had operated with electric headlights and had never heard one express an unfavorable opinion of them.

Mr. Murray testified in favor of the electric headlights, saying they had given satisfactory results on the North Western. Asked whether he thought the proposed rule of the commission was a feasible one for all roads, he said it would be necessary for each road to study its own conditions and to adopt the type of light most suited to its requirements. In reply to a question by Chairman Meyer he said he did not raise any question about the fairness of the test.

The remainder of the hearing was held before Examiner-Attorney E. W. Hines. J. Doherty, road foreman of engines of the Michigan Central, who was a locomotive engineer up to ten months ago thought that electric headlights were a positive menace to safe or prompt transportation on multiple tracks and said that the better the light the worse it is in a fog because of the effect of the moisture in the air on the rays of light. He said that if dimmers were used when passing stations or signals they would have to be used most of the time on a busy railroad. Mr. Doherty said that the views of most engineers he talked with agree with his.

Among the 20 witnesses called by the railroads were several engineers who presented remarkable testimony as to the methods of the Brotherhood of Locomotive Engineers in dealing with its members who disagree with the legislative plans of the brotherhood officers.

W. H. Rother, an engineer employed on the Cleveland, Cincinnati, Chicago & St. Louis, testified that he had been tried and acquitted by his local division of the brotherhood, No. 492, at Indianapolis, on charges preferred by Grand Chief Engineer Warren S. Stone of violation of the "laws" of the brotherhood in testifying before the Interstate Commerce Commission on September 30, 1915, that he regarded electric headlights as dangerous. After his acquittal, Grand Chief Stone had recalled the charter of Division 492 and organized a new division, No. 546, in its stead, excluding Rother, together with those who had voted for his acquittal, and those who had refused to obey an order to refrain from associating with Rother.

J. T. Heller, another Big Four engineer, testified that he had been expelled from Division 143 of the brotherhood on charges preferred by Stone because of his testimony before the Interstate Commerce Commission.

A. E. Martin, also a Big Four engineer, said that he had been excluded from Division 546 and ostracized by his fellow members for acting as Rother's attorney at his trial, and that the only evidence presented against Rother was a

copy of his testimony before the Interstate Commerce Commission.

O. P. Keller, an engineer employed on the Pennsylvania Railroad, testified that he had been tried and acquitted by his local division, No. 74, on charges preferred by order of Grand Chief Stone because he had expressed an opinion unfavorable to electric headlights in the presence of a member of the Pennsylvania legislature, and that he had afterward been expelled on charges preferred by Stone because he had joined the Pennsylvania Mutual Benefit Association. He also testified that he had sent to the Interstate Commerce Commission a copy of a circular addressed by Mr. Stone to members of the brotherhood, threatening them with expulsion if they interfered with the plans of the brotherhood in connection with headlight legislation.

D. P. Trostle, an engineer on the Philadelphia & Reading, testified that H. E. Wills, legislative representative of the Brotherhood of Locomotive Engineers, and A. G. Pack, assistant chief inspector of locomotive boilers of the Interstate Commerce Commission, had warned him while in the hearing room of the Interstate Commerce Commission on October 30 that he would be violating the laws of the brotherhood if he testified unfavorably to high-power headlights.

These engineers were allowed by the Interstate Commerce Commission to present their testimony only after vigorous objection by Mr. Stone and W. S. Carter, and after the hearing had been interrupted for a day while the commission deliberated over a statement filed by counsel for the railroads, outlining the character of the evidence they proposed to introduce. After the testimony had been allowed, Mr. Stone admitted the principal facts alleged and identified copies of letters which he had written bearing on the cases.

The sections of the "Constitution and Statutes" of the Brotherhood of Locomotive Engineers under which members have been expelled for giving testimony before the Interstate Commerce Commission are given herewith:

"MEMBERS INTERFERING WITH BOARD—PENALTY."

"Sec. 11. Any member or Division refusing to sustain the official acts or instructions of the Legislative Board, or who circulates or signs any petition, or who, by verbal or written communication to railroad officials or others, calculated to injure or interfere with legislative matters offered by the Legislative Board or at any time makes suggestions to railroad officials or to state legislators that may be detrimental to the interests of the B. of L. E., or any train service organization, shall be expelled, when proven guilty, as per Sec. 49 of the Statutes."

"INTERFERING WITH NATIONAL LEGISLATIVE MATTERS."

"Sec. 12. Any member or Division who, by verbal or written communication to anyone calculated to injure or interfere with national legislative matters, offered by our Legislative Representative at Washington or Mexico, or at any time makes suggestions to anyone that may be detrimental to the interests of such legislation, shall be expelled, when proven guilty, as per Sec. 49 of the Statutes."

Nearly a score of engineers running fast passenger trains on roads entering New York City testified that, in their opinion, electric headlights would be a positive menace to safety of operation in their territory because they obscured signals and temporarily blinded engineers who had to face such headlights approaching from the opposite direction. Some of them had had experience with electric headlights on their own engines, others had faced them on electric trolley lines paralleling their own lines, and all of them had been present at tests with electric headlights made on the New York Central recently. In addition, 45 locomotive engineers and 13 road foremen of engines and locomotive inspectors presented to the commission through counsel for the railroads a petition that they be allowed to testify, but the commission declined to change the ruling it had previously made limiting the number of witnesses to 20 for the railroads and 20 for the brotherhoods.

Frank McManamy, chief inspector of locomotive boilers of the Interstate Commerce Commission, took the stand as the first witness for the brotherhoods. He said that before recommending to the commission the rule requiring a headlight which would enable a dark object the size of a man to be seen for a distance of 1,000 feet down the track, he had

made such investigation of the subject and such tests as time permitted and that he had examined the headlight laws of 31 states, mostly in the west and south. Most of these laws require electric headlights, while some specifically prescribed electric headlights. He had chosen the distance basis to make the rule enforceable, as apparatus for the measurement of candlepower was too cumbersome for inspection purposes. He emphasized the fact that the order permits the use of dimmers to reduce the intensity when passing stations or other trains. He thought the conditions of the New York Central tests were not entirely favorable, especially as to the observation of men on the track, as they were partially obscured by shadows and curves. However, he thought this was the least important feature of the tests because he thought the lights used were of even greater than the required intensity. He said that it was raining intermittently during the tests, that he had not been consulted in detail about the arrangements for the tests, and that he had been given no opportunity to inspect the lights on the night of the test. He said he had experienced no difficulty in reading signals.

John McManamy, assistant chief inspector of locomotive boilers, described his experience at the tests at New York and said that he had found no difficulty in reading signals, but that he thought the lights were not in proper condition.

A large number of engineers employed on western railroads that have used electric headlights for years testified as witnesses for the brotherhoods and expressed a preference for electric headlights, saying they had never had any difficulty in reading signals and that they believed that the high-power light was a safety device. An engineer on the Chicago & North Western said that their lights were focused so that the beam of light strikes the track at a distance about 300 feet in front of the engine so they do not shine directly into the eyes of an engineer on the opposite train. The brotherhoods completed their case without giving any rebuttal testimony to the charges of intimidation and coercion.

R. B. Kendig, chief mechanical engineer of the New York Central, and D. F. Crawford, chairman of the Headlight Committee of the American Railway Master Mechanics' Association, and general superintendent motive power of the Pennsylvania Lines West, gave rebuttal testimony for the railroads. He stated that he would never take the responsibility for putting electric headlights on any road and that the danger increased in proportion to the density of traffic, the number of trains and the number of signals. He stated that a proper rule would prescribe the minimum that would be suitable under the most congested conditions and allow each road to use more intense light if desired.

After the taking of testimony had been completed the hearing of oral arguments was set for November 27. After listening to the arguments which were presented at that time, the commission took the matter under advisement without comment.

In his argument, Solicitor C. C. Paulding, representing the railroads, pressed the point upon the commission that what might be satisfactory and safe on one railroad might be impracticable and dangerous on another, because of the variance of local conditions, and that what can be used on the single-track lines in the sparsely-settled regions of the West might be utterly impossible on the multiple-track roads of the East and in the congested districts and suburbs around the big cities.

A feature of Solicitor Paulding's argument was the statement that the brotherhood chiefs, in expelling engineers from membership for testifying to their belief that the electric headlights are dangerous, had violated the Federal Penal Code, which prescribes a fine of \$5,000 and six years' imprisonment for intimidation or wrongful influencing of witnesses in a proceeding before a United States court or commissioner. The railroads' counsel scathingly denounced the brotherhood constitution provision providing that "any mem-



ber who interferes with a legislative matter being conducted by the legislative board shall be expelled." He called attention to the warnings sent broadcast to engineers that they were subject to expulsion if they testified.

With the testimony of the brotherhood witnesses so directly contradictory of all the mass of testimony of engineers and others who testified of difficulties in vision through false colors, reflections and blinding glare from the high-power lights, as produced by the railroads, the two could not be reconciled and it resolved itself into a matter of the credibility of the witnesses. He urged the commission to consider that 85 engineers had appeared voluntarily to testify against the "searchlights" in spite of the drastic punishment inflicted upon a score of their fellows for giving evidence previously and in face of the fact that under the law of the brotherhood they could be expelled for attending. He said that the sworn testimony given at such great personal risk, all corroborative of the contentions of the railroad operators, was entitled to the utmost credence. He quoted numerous expressions, including that of one engineer that he had voluntarily come "to protect myself and the public against the enforced use of a device which means death."

Grand Chief Stone made the only argument for the electric headlights, speaking for two hours and citing the testimony of member engineers that they had had no trouble whatever in using the intense headlights on western roads, such as being blinded by the dazzling glare when trains meet, misreading of signals through false colors, phantom lights and reflections, as described by a score of engineers called by the carriers and testified to as the result of numerous tests. He insisted that the electric headlights should be considered a safety device.

**ADJUSTABLE AIR PUMP BRACKET**

It is usual for a railroad to maintain a variety of air pump bracket castings to fit various sizes of air pumps and diameters of boilers, as well as to suit the vertical location of the bracket relative to the center of the boiler, on different classes of locomotives.

In an effort to reduce the number of brackets required,

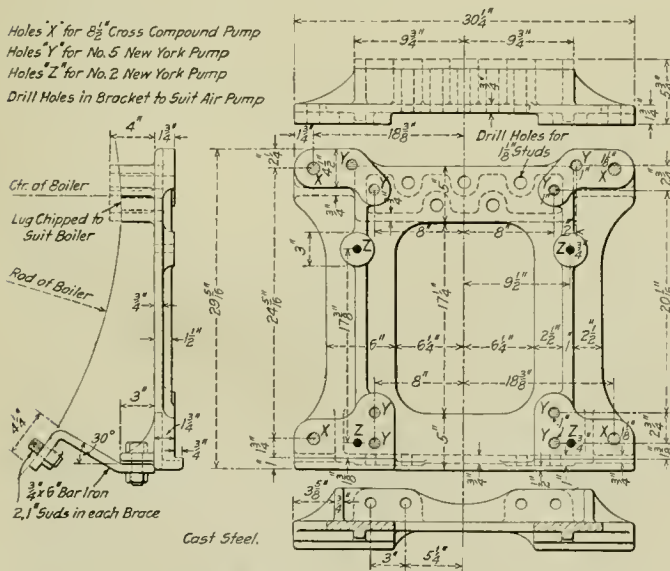

Adjustable Air Pump Bracket in Use on the Union Pacific

the design as illustrated was developed by the mechanical department of the Union Pacific. A light, but strong steel casting, having at its upper end a suitable chipping boss, and at its lower end lugs designed to take the ends of bar iron braces, constitutes the support for the pump. Bosses

cast on the face of this casting are arranged to take studs for three different styles of pumps: the Westinghouse 8 1/2-in. cross compound pump, and the No. 2 and No. 5 New York pumps.

Any variation in the fit of the bracket to the locomotives is taken care of by increasing or decreasing the length of the bar iron braces, this being clearly indicated in the illustration.

**SAFETY VALVES**

BY M. J. CAIRNS

The instructions on the reverse side of the government alteration report, Form 19, request, under item F, that changes in the number or capacity of safety valves from those shown on the original specification card shall be reported on an alteration report. It is fair to assume that the back shop and roundhouse forces on many roads are not aware of the number and size of the safety valves shown on the specification card, as those cards are usually on file in the mechanical engineer's office. As a means of giving the shops this information it is suggested that a drawing conveying the information shown in Fig. 1 be made and that blue prints be posted in roundhouses and back shops with instructions that it be referred to when making a change in the safety valves. As the valves shown on this drawing

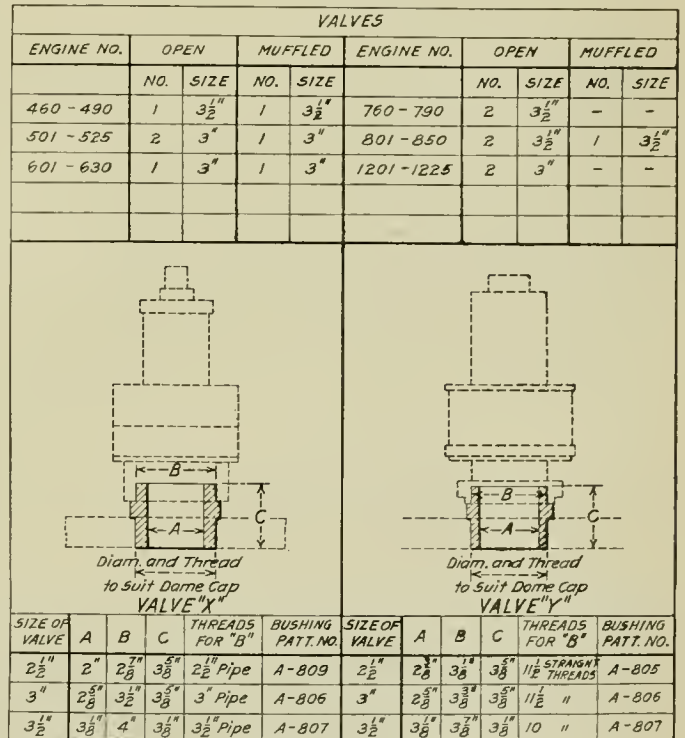

Fig. 1—Suggested Tabular Arrangement for Safety Valve Data

should represent those which will properly relieve the boiler it will be well to check their number and size by the Master Mechanics' formula which is given below, assuming that the valves have a 45 deg. seat.

$$D = .036 \times L \times P$$

In which  
 D = the total of the actual diameters of the inner edge of the valve required.  
 H = total heating surface of boiler in square feet (superheating surface not to be included).  
 L = vertical lift of valve in inches.  
 P = absolute boiler pressure (boiler pressure plus atmospheric pressure) in pounds per square inch.

The lifts for the various valves can be obtained from the manufacturers.

The locomotives can be arranged in numerical order or by

classes, whichever is preferable, and the number, size and style of the valves should be shown in the space provided, it being understood that no valve smaller than those shown in the table shall be applied. It will, of course, be permissible to apply valves larger than those shown in the table if the correct size is not on hand. It is common practice on some roads to equip switch, passenger and road engines in switching service with one muffled and one or two open valves, equipping freight engines with all open valves; it is claimed that no objection can arise from the noise of an open valve if no objection arises from the shriek of a whistle.

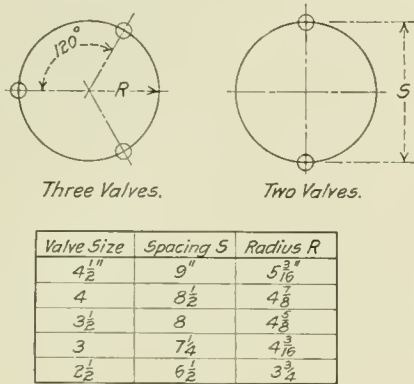

Fig. 2

This in itself is an economy as muffled valves are usually more expensive than open valves.

For new work, and perhaps for replacements, the spacing of valves shown in Fig. 2, which is recommended by the Master Mechanics' Association, can be used to advantage.

The brass bushings shown in Figs. 3 and 4 will be found an improvement over a pipe bushing on account of their better wearing qualities. Furthermore, the valves can be removed from the brass bushing without the injury they are at times subjected to when pipe bushings are used. The distance between the bottom of the valves and the dome cap should be as short as possible, leaving just enough space for

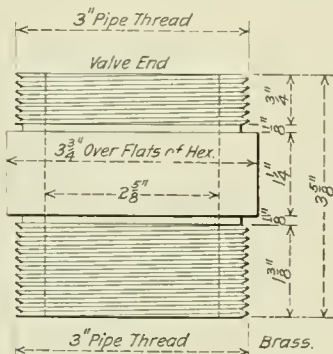

Fig. 3—Bushing for 3-inch Valve

the use of a hexagon wrench. A long bushing with the consequent vibration of the valve when it is blowing is injurious to the valve. Fig. 4 shows a reducing bushing which can be used when applying the smaller valves to the engine. If the valves on the road are all of a standard make, these bushings can be carried in stock threaded, otherwise they should be left blank and threaded to suit the dome cap and valve as required.

Safety valve springs are usually designed to carry a pressure of 10 lb. under or over the pressure stamped upon them, although some manufacturers allow a variation of 15 lb. It is, therefore, important that the shops not only compare the size of valve with the above mentioned drawing but also compare the spring capacities. This is most important

when changing valves from one engine to another. It is suggested that springs at 150 lb., 170 lb., 190 lb. and 210 lb. be carried in stock as standard rather than carrying a number of springs with pressures varying 5 lb. or 10 lb. This not only greatly reduces the number of springs carried in stock but also protects all engines on account of the range of 20 lb. allowed each spring. As the outside diameter of the spring is usually alike for safety valves of the same size, type and make, one valve body and several spare springs can be carried in place of several complete valves with springs at

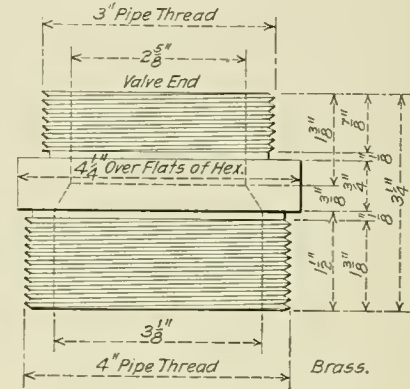

Fig. 4—Bushing for Replacing 3 1/2-Inch Valve with 3-Inch Valve

various pressures. The store department can protect the entire equipment by carrying a spare valve for each 50 engines.

Too much importance cannot be given to the obtaining of correct valves on locomotives and it will be found a paying proposition to assign one man at each shop to handle the application of safety valves.

### REPORT OF I. C. C. DIVISION OF BOILER INSPECTION

The summary of the work of the division of boiler inspection of the Interstate Commerce Commission is included in the report of the commission for the year ending June 30, 1916, which has just been published. During the year the jurisdiction of the division has been extended to include the entire locomotive and tender. The work of the division in inspections and accidents reported, including all parts of the locomotive and tender since the extended jurisdiction became effective, is summarized in the following table:

Number of locomotives inspected.....	52,650
Number found defective.....	24,685
Percentage found defective.....	47
Number ordered out of service for repairs.....	1,943
Number of accidents.....	537
Number killed.....	38
Number injured.....	599

Separating the accidents, and casualties resulting therefrom, due to boilers and their appurtenances only, from those due to other parts of the locomotive, it shows that there were 352 such accidents, with 29 killed and 407 injured thereby. This is a decrease over the preceding year in the number of accidents and in the number of casualties, but an increase in the number killed due almost entirely to crown sheet failures due to low water, and forcibly emphasizes the importance of properly maintaining water gages and boiler feeding appurtenances.

A total of 653 applications for extension of time for removal of flues, as provided in rule 10, were filed during the year. Investigation disclosed 103 of the locomotives in such condition that no extension could properly be granted; on 79 locomotives the conditions were such that the full extension asked for could not be granted, but an extension for a shorter period was allowed. Sixty-three extensions were granted after defects disclosed by our inspections had been repaired; 43 applications were withdrawn. The remaining 365 were granted as requested.

# Car Department

## HOPPER CAR OF 200,000-LB. CAPACITY

Although there are several cases where hopper cars of greater than 50 tons capacity are in use, the 50-ton car is still the standard for this type of equipment. Until recently the most notable examples of higher capacity equipment were the 90-ton high side gondola cars which have been in service

it was in service it handled 11,800 tons of coal with no repairs to the car whatever, the only repairs being to air brake hose.

The car is 52 ft. 2 in. long over the striking plates and has a maximum height of 12 ft. above the rails. It will be noted that the hopper angle is 40 deg. from the horizontal, this having been adopted to make the car self-cleaning for ordinary

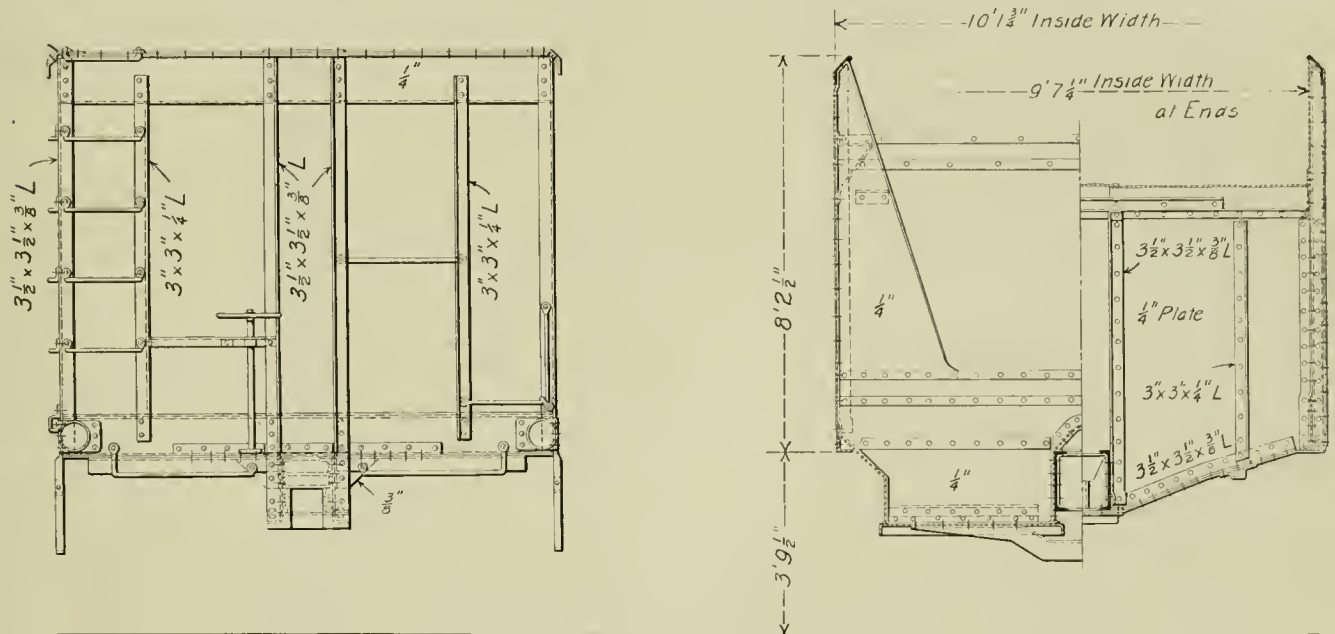

End Elevation and Cross Sections of the Woodward Iron Company's 100-Ton Car

on the Norfolk & Western since the latter part of 1912. A car of 100 tons rated capacity, however, has been built for the Woodward Iron Company, Woodward, Ala., by the

run-of-mine coal. The use of this angle limits the length of the hopper at the top to 46 ft. 4 in., the use of the space at either end over the outside wheels of the six-wheel truck be-



100-Ton Coal Car—Woodward Iron Company

Pressed Steel Car Company, which has now been in coal carrying service for about two years, during which time its performance has been very satisfactory. The first year that

ing thus impossible. The cars are 10 ft.,  $1\frac{3}{4}$  in. wide inside and have a capacity of 3,600 cu. ft. The light weight is 75,300 lb., and considering the maximum carrying capacity



as 10 per cent overload, the ratio of revenue load to total weight of car and lading is 74.5 per cent. This is somewhat less than the same ratio for the Norfolk & Western cars referred to above. These cars with a maximum capacity, including 10 per cent overload, of 198,900 lb. and a light weight of 59,000 lb.,\* have a ratio of revenue load to total load of 77 per cent, six-wheel trucks being used in both cases. The ratio is better, however, than the average 50-ton

hopper to the draft sills. The end sill is a 10-in., 15-lb. channel, which is placed across the top of the center sills, 2 ft. 11 in. back of the striking plate. The projecting ends of the center sills are stiffened by means of 6-in. by 3½-in. by ⅜-in. angles extending from the end of the sills to the ends of the transom, to which they are attached by means of ⅜-in. horizontal gusset plates. In front of the end sill the center sill cover plate is widened to form a deck, completely covering

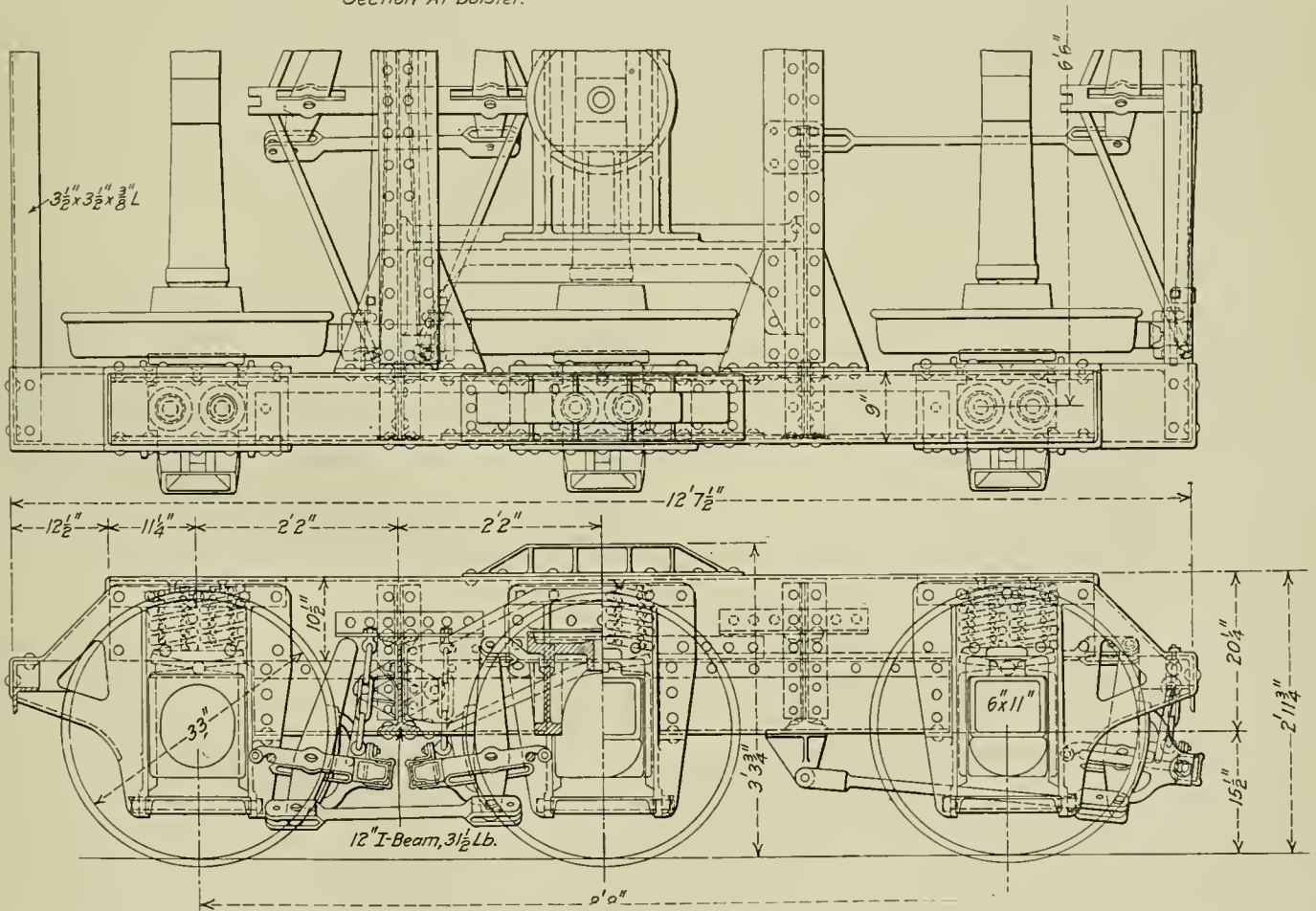
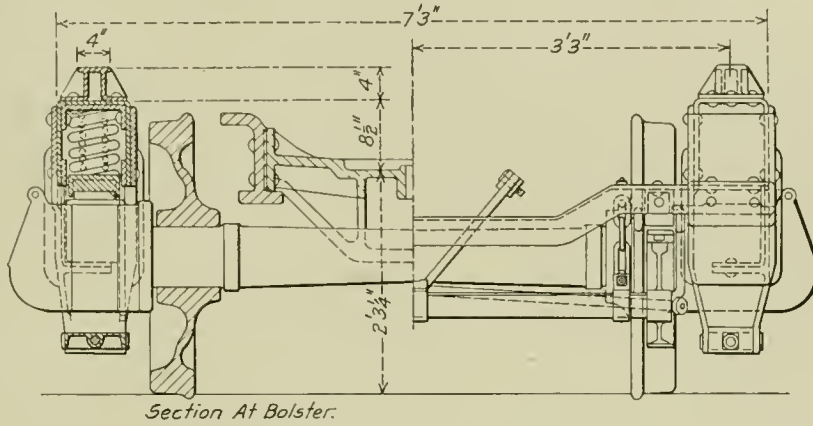

Built-Up Six-Wheel Truck for Woodward Iron Company's 100-Ton Car

car with four-wheel trucks, which is about 72 per cent.

The underframe is of the through center sill design, the sills being 15-in. channels placed with the flanges inward and having a width from back to back of 13 in. Top cover plates 5/16 in. thick and 13 in. wide extend from about 12 in. inside the hopper to the end sill and the bottom flanges are stiffened by the use of 3½-in. by 3½-in. by ⅜-in. angles riveted to the outside of the sills. These extend from the

space between the center sills and the diagonal stiffeners.

The transom is of unique construction. It is carried from the center and side sills up to the bottom of the hopper sheet and consists of vertical ¼-in. plates extending from either side of the center sill to the side of the car, the edge of the plate at the center sill being stiffened vertically by two 3½-in. by 3½-in. by ⅜-in. angles, one on either side, at a point above the side bearing by one 3-in. by 3-in. by ¼-in. angle placed on the side of the sheet toward the end of the car, and at the

\*A more recent design of this car has a weight of 53,000 lb.

outside to the back of a 3-in. by 3-in. by  $\frac{1}{4}$ -in. angle and the web of a 3-in., 9.8-lb. Z-bar. These two members in effect form the cornerpost of the body side frame. The space between the end of the end sill and the transom is closed by a  $\frac{1}{4}$ -in. pressed steel channel, the upper flange of which is flattened out to permit the end of the piece to be riveted between the flanges of the angle and Z-bar members of the post. Flanges are formed at the lower end of the transom plate by two  $3\frac{1}{2}$ -in. by  $3\frac{1}{2}$ -in. by  $\frac{3}{8}$ -in. angles, one placed on either side; at the outer end these are riveted to a  $\frac{3}{8}$ -in. gusset plate to which are also attached the flanges of the body and end sections of the side sill and the diagonal channel stiffeners. The two sections of the transom are further stiffened and securely tied to the center sill by a  $\frac{1}{2}$ -in. bottom cover plate, extending across the center sill from gusset plate to gusset plate. This cover plate tapers from the width of the transom flanges at the ends to a width of 20 in. under the center sill. Pressed steel diaphragm fillers are placed between the center sills at points about half way between the ends of the hopper and the center of the car, and the center castings form fillers at the transoms. The side sills are  $3\frac{1}{2}$ -in. by  $3\frac{1}{2}$ -in. by  $7/16$ -in. angles.

The end plate is a  $\frac{1}{4}$ -in. pressed steel member of Z-bar section, to which is riveted the upper end of the hopper sheet. The end of the hopper is supported by four  $3\frac{1}{2}$ -in. by  $3\frac{1}{2}$ -in. by  $\frac{3}{8}$ -in. angles, one at each corner and one on either side of the center sill. In addition to these members two 3-in. by 3-in. by  $\frac{1}{4}$ -in. angles are provided to support the ends of the grab irons and ladder irons. The end hopper sheet is a  $\frac{1}{4}$ -in. plate, which is supported throughout its width at the transom and from the center sills at a point midway between the transom and the bottom of the hopper. On the interior of the car the center sills are covered with a housing of  $\frac{1}{4}$ -in. plate, which extends below the sides of the sills to form the inside portion of the drop door frames.

There are four sets of doors, those on opposite sides of the center sill being joined by special pressed steel channels, to the center of which are attached the door chains, the operating mechanism being housed between the center sills. To make the car entirely self-clearing, the space between adjoining sets of doors is hopped, the hopper sheets being supported from transverse stiffeners of  $\frac{1}{4}$ -in. plate which extend vertically across the car. At the top these stiffeners are flanged to form a half-diamond section, the diamond being completed by a similar section, riveted in place.

The sides of the car are braced to these members by pressed steel plates,  $\frac{1}{4}$ -in. thick, the lower edges of which are riveted between the two pieces of the transverse stiffeners. The sides of the car are also joined near the top by four cross ties of diamond section, the ends of which are secured to vertical stiffeners of  $4\frac{1}{2}$ -in. by 3-in. by  $\frac{3}{8}$ -in. T section. Longitudinal stiffness of the sides at the top is provided by a 6-in. by 3-in. by  $\frac{3}{8}$ -in. special bulb angle.

The cars are carried on six-wheel trucks, the distance between truck centers being 39 ft. The truck is of pressed steel construction, having a wheel base of 8 ft. 8 in. The principal member of the side frame is an inverted U-section of  $\frac{1}{2}$ -in. plate, 9 in. wide by  $10\frac{1}{2}$  in. deep, the outside flange of which is riveted to a pressed steel angle, which gives the frame a total depth of  $20\frac{1}{4}$  in. between the pedestals. The transoms are 12-in., 31.5-lb. I-beams, which are securely framed and gusseted to the side frames and provided with top and bottom cover plates  $7\frac{1}{2}$  in. wide by  $\frac{1}{2}$  in. thick. The transoms are located 2 ft. 2 in. on either side of the center of the truck and support two heavy longitudinal steel castings which carry the cast steel bolster.

The pedestals are steel castings and are riveted to the side frames. The load is transmitted from the side frames to the journal boxes through two  $6\frac{1}{4}$ -in. by 8-in. double coil springs over each journal box. The springs do not rest directly upon

the top of the box, an equalizing spring seat being interposed between the box and the springs. The pedestals are closed at the bottom with binders. The wheels are 33 in. in diameter and are mounted on axles with 6-in. by 11-in. journals.

## PORTABLE CUT-OFF SAW

BY E. W. HARTOUGH

General Foreman, Car Department, Missouri, Kansas & Texas, Denison, Texas

A portable saw, which is operated by compressed air, has been developed and placed in service in the car repair yards of the Missouri, Kansas & Texas, at Denison, for cutting up roofing, decking, lining and siding. It has proved to be both a time and money saver, as it permits the handling of the lumber directly from the pile to the saw and thence to the supply car, to be delivered about the yard wherever needed, thus eliminating handling to and from the mill.

The saw is mounted on the end of a table 10 ft. long by 2 ft. wide and is operated by a compressed air motor. The saw carriage and motor are moved back and forth in a four-rail guide, two rails being placed above, and two below the saw. The inner rails are bolted to the legs of the table and the outer ones are riveted to brackets which are attached to the table legs. Four small grooved wheels attached to the carriage operate on the rails. A wooden hood is provided to protect the operator when the saw is not in use.

A narrow-gage track runs the full length of the lumber yard parallel to the supply track. This provides a means

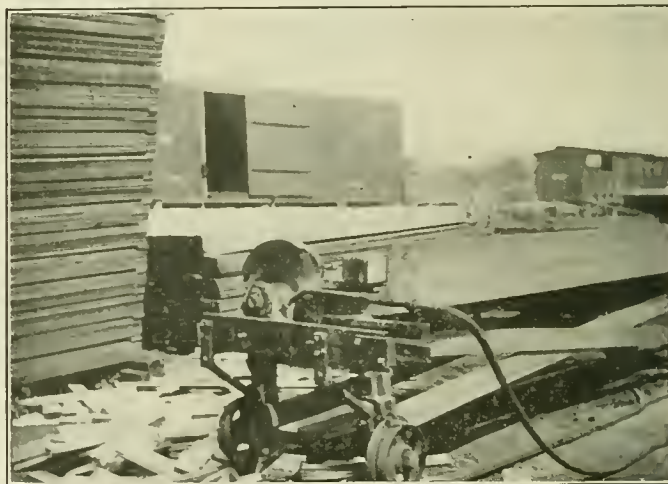

Portable Saw Used in Car Repair Yards

of moving the saw directly to the pile in which the lumber to be cut is stored and, when cut to length, the material may be loaded directly onto a supply car for delivery to the repair tracks.

While compressed air is undoubtedly expensive power, the saw uses very little air, as the power is shut off at all times except when the saw is actually in operation. The motor is started on pulling the saw forward towards the lumber and is shut off again automatically as soon as the cut is completed and the saw pushed back to its original position. The motor which has been applied to the saw was manufactured by the Baird Pneumatic Tool Company, Topeka, Kansas, and operates at from 1,900 r. p. m. to 2,000 r. p. m. The saw is 14 in. in diameter and readily cuts through a pile of six sheathing boards at one time. A saw of this kind can be used advantageously at any small repair yard, where compressed air is available for testing air brakes. If compressed air is not available it is possible to use a small electric motor.

With this one saw it has been possible to cut all the material used by 100 piece workers and with plenty of small supply cars available, no extra handling is necessary.

# CAR INSPECTORS' AND FOREMEN'S MEETING

Individual Papers and Committee Reports a Most Important Feature of the Proceedings at Indianapolis



FOR the first time in its history a number of individual papers or reports were presented at the annual meeting of the Chief Interchange Car Inspectors' and Car Foremen's Association, which was held at Indianapolis, Ind., last October. The account of this meeting which appeared in our November issue was concerned principally with the discussion of the changes in the rules of interchange, and included also the first prize article in the competition which was held by the association on car department apprenticeship. The second prize article in this competition and some of the individual papers follow. Other reports will be published in the January number.

## FREIGHT CAR MAINTENANCE

BY L. J. JUSTUS  
New York Central

The importance of freight car maintenance cannot be overestimated, as the amount annually spent for this purpose staggers the imagination. The all-important matter is how to spend this vast sum of money so that the best possible results will be obtained. Shall it all be spent in maintaining the present light capacity wooden cars, repairing them to their original standard when broken or worn out, or shall a part of it be spent in "betterments" strengthening this type of car by applying steel underframes, steel or strengthened ends, up-to-date draft rigging, steel carlines, metal roofs and doors that are not liable to drop off and will prevent water getting into the car and damaging the lading? Much depends on the decision of these questions. It has been the experience of a large railroad that the wooden car, especially the box car, in a generally good condition, should be repaired with a steel underframe, having an improved draft-rigging and strengthened ends, rather than to be repaired to its original standard.

These are the three courses open to the car owner; if sufficient money is available, the old cars may be torn down and replaced with large capacity steel or steel underframe cars.

If money is not so abundant, which is the usual condition, the wooden car, particularly the box car, of not less than 60,000 lb. capacity, can be rebuilt with a steel underframe, improved draft-rigging, strengthened ends, etc.; or if the size of the box car is large enough, it could have new trucks of larger capacity, the carrying capacity of the car thereby being increased. The point is often brought up by those in charge of repairs of freight equipment on the smaller roads having light locomotives, that the present wooden car is all right and that they can handle their business satisfactorily with it in its present condition without spending large sums of money to strengthen it. This point might be well taken if their cars always remained on their own roads, hauled in short trains by small locomotives, but this is not the case. These cars go all over the country and are subjected to the same conditions of service as the modern steel or steel underframe cars, hauled in the same trains and subjected to the same hump yard switching, with the result that the center sills are cracked or split, the draft arms or bolts broken, allowing the draft arms or the coupler to be pulled out.

Particular attention should be called to the importance of maintaining the doors of box cars in good condition. It is not an uncommon thing to see doors having no metal stiffeners at the bottom, with the corners torn out or rotted away at the point where they should engage the door guides, swinging in and out as the train moves along, with nothing to hold them in place but the door hasp, and liable at any minute to drop to the ground. All doors, when rebuilt, should have a substantial metal bottom stiffener and not less than four deep door guides, securely fastened to the car and a good strong door hasp fastened to the door with at least four bolts. The hasps should, by all means, pass through one of the horizontal battens, all of which should extend the full width of the door. The door should have a good track, substantial hangers, and interlocking spark-strips, which will hold the door securely in place and prevent water leaking into the car around the edges. The practice of "repairing in kind" cars having wooden door

stops is another bad thing, as the hasp fastener attached to the wooden door stop with two bolts will not stand modern service conditions, and the wooden door stop is soon split and the hasp fastener torn out. I am sorry to be obliged to say that I have seen new cars built this year with wooden door stops, and with hasp holders attached to the door with only one bolt. The repairs to damaged ends are often made with no regard to strength. If the top is pushed out it is crowded back into position and held in place only by a few nails and a new fascia board; if the end sill or an end post is broken, a new one is applied and the end posts fastened to the end sills only with nails and some new end sheathing boards applied. This end, after repairs are made, looks all right, but has not the strength to withstand the shocks that it will be subjected to.

Just as much importance should be attached to the quality of the work turned out as to the quantity. It has been found from a thirty-day record kept on 6,000 miles of railroad that steel and steel underframe cars are in for repairs to draft sills and draft attachments not oftener than once a year and the modern cars considerably less than that, while wooden cars, with wood draft arms, are in for the same class of repairs about two and one-half times a year. It has been the experience of at least one road that wooden cars equipped with properly designed repair steel underframes will hold their own in service with modern steel and steel underframe equipment, and that there is a marked reduction in repair bills when these cars are on foreign roads, especially if they also have steel ends. The present practice of replacing arch bar trucks with cast steel side frames is a move in the right direction, as it does away with some bolts that have always given us much trouble to maintain. Standardization of the design of parts is one reason for the great reduction in maintenance cost.

We should at all times report to the proper officers to have defective designs improved to obtain easier, better and cheaper maintenance. If there is some weak point in a certain series of cars, which is constantly failing, we have not done our full duty by simply repairing these cars. We should earnestly devote ourselves to the task of overcoming this inherent defect in existing cars, in design or material, by such changes as will strengthen the part that has given the trouble and thus put a stop to this unending repairing of this particular defect. In the designing of new equipment the men that are in actual charge of the maintenance should be consulted and work with the designers of the equipment, not only at the time when the cars are designed, but after the cars are in service, following them up and reporting from time to time to the mechanical department any defects that may develop, with the idea of having the design changed in the next lot of cars built. A great improvement in the quality of repairs made to freight cars would be apparent in a very short time, if the men in charge were at all times near the work, giving it their close personal supervision instead of being obliged to spend so much of their time attending to office duties which should be handled by others.

BY H. H. HARVEY

General Car Foreman, Chicago, Burlington & Quincy, Chicago

The writer will only attempt to call attention to some of the little things that are so frequently overlooked as cars pass over repair tracks. Following are some of the things that should be done to every system freight car:

Inspect all brake hangers, pins, brackets, rods and levers and replace any defective ones. See that all brake pins are provided with good cotters or split keys, with both members well spread. See that the brake beam safety bars are securely fastened to the spring plank.

Inspect the journal boxes, brasses and wedges and remove worn or broken ones. When wheels are changed care should be taken to see that the tops of the boxes are not worn on

the inside and that the backs of the wedges are not worn flat. Dust guards should always be looked after when the wheels are changed. Give the journal box packing the needed attention. See that the journal box and column bolt nuts are tight and secured with cotters, split keys, nut locks or lock nuts.

Give the hand brakes a thorough test. Have the safety appliances throughout the car thoroughly inspected. Test the air brakes and give special attention to leaks. Test the air hose under pressure with soap-suds and remove any spongy hose. See that the angle cocks are properly located and set at the 30 deg. angle.

Gage the couplers and make the necessary changes. See that all carrier iron, draft casting and follower strap bolts are tight and that the nuts are secured with cotters, split keys, nut locks or lock nuts. See that the body truss rods are tight and the car has the proper camber.

See that the side door hasps are properly located to bring the front edge of the door up tight against the stop when the door is in the closed position. See that the lower brackets at the back end of the side doors are so located that the door cannot be pried over the bracket. See that the side door tracks are tight.

See that the ends of box cars are grain tight, special attention being given to the small openings around the end posts. See that the sheathing under the corner bands on box cars is well nailed. See that the sides of box cars are grain tight at the posts and braces. If the car has a steel underframe, care should be taken to see that the side sill nailing pieces are not split or decayed. Have the floors in box cars grain tight. Narrow flooring in box cars is preferable to prevent undue shrinkage. Oakum will be found satisfactory for calking cracks in the floors.

Inspect refrigerator cars from the inside with the doors closed to detect small openings around the side doors and hatch covers. These openings should be closed before the car is permitted to leave the repair track.

Give the dump door mechanism on gondola cars special attention to see that it is in good working condition and that no small bolts, pins, cotters, etc., are missing.

If the items mentioned are handled as outlined, it will result in much good and add very little to the maintenance cost of freight cars. Foreign cars will also require more or less attention as to these details, but as a general proposition cars reach their home rails often enough for the owner to take care of most of the parts mentioned.

#### DISCUSSION

F. H. Hanson (N. Y. C. West): Both of these papers contain excellent ideas that we should all think about. We all know that some of the larger railroads are spending a great deal of money for additions and betterments in putting steel under-frames under cars, and using good, substantial draft gears, metal roofs and metal ends, and that they are inclined to put on doors that will cause the least trouble as well as protect the load; it is to be regretted that other roads are not doing this. The railroads that are doing this class of work are compelled to handle the cars of other roads that are spending very little money to put their cars in shape. The only solution of the problem seems to be for the railroads having the good equipment to tighten up on their inspection to protect themselves. Some of the trains have as many as 125 cars. With the class of equipment that gets in those trains we are having heavy expenses in making repairs which should properly be borne by the owners, as the damage, as a rule, is caused by a weakened condition of the equipment, and failure on the part of owners to properly maintain their cars. As the interchange rules now stand, I can see no other way for the lines that are spending this money to protect themselves except to tighten up in inspection.



T. J. O'Donnell (Buffalo): I want to emphasize the fact brought out in Mr. Justus' paper on the dilapidated condition of side doors. The owners of many cars make no attempt to maintain proper doors. Some have but two guides and they are out of line. Mr. Justus is in a position to know what should be done in the way of doorway protection. I think there should be united action to absolutely refuse such cars in interchange. Fastening up the doorway and taking the load away from it does not correct the evil. We have no less than 100 to 150 doorway orders—fixing up doors to try to overcome transferring the load. I think it an evil that could be corrected if every foreman and every inspector would make it a special point to take it up with the proper official and see if something could be done to get better doorway protection. The old type of door hanging is of no benefit now. The service is too severe. I heartily commend Mr. Justus' suggestion that four door guides of the deep type should be put on every house car door so that it will not get out of place should one of the guides happen to become lost.

J. J. Gainey (C. N. O. & T. P.): I heartily agree with both Mr. Justus and Mr. Harvey. The steel under-frame is the thing to put under a car. It is economy for any road and a step in the right direction.

F. C. Schultz (Chicago): It appears to me that the only method we could follow towards correcting this evil would be to work out a plan for a change in the rules by which a certain class of construction can be refused in interchange. I know of cases where we have had to transfer cars five or six times. Until we can work to a general standard we cannot solve the problem of handling such equipment.

H. Boutet (Cincinnati): Mr. O'Donnell's remarks on door guides are timely. At our interchange points we are bothered with the adjustment of side doors on account of the lading shifting. On some roads it is almost a crime for a delivering line to deliver a car with certain commodities unless the car is provided with doorway protection, but the same roads are loading cars at their own freight houses and along their own lines without any doorway protection and with the same commodities for which they require protection.

### CAR DEPARTMENT APPRENTICES

(Second Prize)

BY C. N. SWANSON

Superintendent Car Shops, Atchison, Topeka & Santa Fe, Topeka, Kan.

The question of men, the right kind of men, men by nature endowed and by training specifically fitted for the work they are called upon to do, is the biggest job the railroads and manufacturing concerns have to solve. In the struggle and competition of modern business push, brawn and muscle have necessarily given place to brains and skill. We must be "prepared" to meet the changing conditions. Nowhere is there greater need for "preparedness" than in the question of men. It is necessary that we select the right kind of young men, and definitely and specifically train them for our needs. Nowhere is there greater need for this than in the car department of our railroads.

The best form of an apprenticeship for any one company will depend largely upon each road's definite needs. Our car department apprenticeship system is a part of the elaborate, yet simple, system of apprenticeship which we have planned for the training and development of apprentices in the various trades, a system which has given us excellent results in the form of skilled journeymen, a system which has made it unnecessary for us to go outside our ranks for journeymen or for young men to fill our minor foremanships. The scheme has paid its way in dollars and cents even from the start.

#### APPRENTICE COURSES

*Coach Carpenter Apprentices.*—The course for our coach carpenter apprentices is four years in length, the boy starting

out at \$1 or \$1.20 a day, according to locality, and being given a raise of 15 cents each six months. These apprentices are employed between the ages of 18 and 22. They are given nine months in the cabinet shop, nine months on outside coach body work, nine months on inside coach finishing work, six months on trucks, platforms, piping, and steel work, six months in the freight car shop, and the last nine months in the cabinet shop. Every variety of coach building work is given them, the schedule of work changing to meet the changing conditions. Throughout their apprenticeship they are given as broad experience as possible and upon graduation they are assigned to some particular class of work upon which they soon become experts. Should, however, the needs of the company require them for other work their preparation will have been such that they can easily and quickly adapt themselves to whatever work is assigned. We have had no need for several years now to go outside our ranks for coach carpenters. Several graduate apprentices have been promoted to positions of responsibility and are making good.

*Freight Car Apprentices.*—Our freight car apprenticeship system has been in existence only about a year and a half. The boys are given a 2½ year course and a thorough experience, first on body work of freight cars, requiring light repairs; then on trucks, steel work, and air, and back again



Coach Painter Apprentices

on body work of cars undergoing heavy repairs. These boys start out at 16½ or 18 cents an hour, according to locality, and are given an increase of 15 cents a day each six months. This course has not been in operation long enough for us to have any graduates as yet, but already many of these boys are doing fully as much work and as good work as our regular freight car carpenters. As the freight car work is of a heavier nature than that required of the coach car carpenters, we have made the age limit from 19 to 30 years. The course has been made so thorough that we have had plenty of applicants, one college graduate having been attracted by the opportunities offered.

We also have an apprenticeship course for our coach painters, and another for our coach tanners and coppersmiths.

#### AN APPRENTICE SYSTEM

*Supervisor of Apprentices.*—Any apprenticeship system should be in charge of one efficient head, a supervisor of apprentices, who with his staff plans and directs the work for the entire system. This supervisor must possess qualities of leadership, be able to organize his department, select his instructors, and properly direct them in their work. He

must be able to adjust misfits, and must interest all the shop officers in the apprentices. He should have tact to carry out the necessary changes without friction or ill feeling. He must be a good mixer and know how to get what he goes after. He must be able to outline an efficient course of instruction and above all be able to inspire the best work of his instructors, and be of such a nature as to be heartily loved by all the apprentices. He must be an educator in the true sense of the word, for upon his head rests to a great extent the success of the enterprise.

*Apprentice Schools.*—We have apprentice school rooms equipped and maintained by the company wherein the boys are taught the theoretical part of their trade. These schools are in charge of technically educated men who have also a knowledge of a trade. The apprentices attend these schools during daylight hours on company time. Here they are taught to read a blue print and to make a working sketch. Our carpenter apprentices are taught arithmetic, including fractions and how to solve problems in board measure, how to make out a bill of material and to estimate the cost of various jobs; also the correct name and function of the various parts of a car, and other kindred subjects. The freight car carpenter apprentices are in addition taught the M. C. B. Rules of Interchange. In brief, each boy is taught everything that will help him with his particular vocation,

## PROBLEMS IN ARITHMETIC

1. An order for bolts reads as follows: 10 bolts 45 lb. each, 6 bolts 8 lb. each, 15 bolts 2 lb. each, and 3 bolts 2 lb. each. What is the total weight of the bolts ordered?
2. At 2 cents a pound, what would be the cost of the bolts on the above order?
3. A freight train takes 9 hours to go a distance of 153 miles. What is the average speed per hour?
446. How many square feet in the sides and ends of a box car 38 ft. long, 8 ft. 11 in. wide, and 8 ft. 4 in. high?
447. What would be the cost of painting the sides and ends of this car at 5 cents per square yard?
448. How many pieces of zinc 4 in.  $\times$  6 in. can be cut from a zinc plate 3 ft.  $\times$  6 in.? (The sign ( $\times$ ) as used above means "by.")

*Shop Instructors.*—Each master mechanic takes pride in showing his apprentice school room to visitors and in pointing out the good work of his boys. But proud as we are of our school room instruction we are prouder still of the work done by our shop apprentice instructors. The place to learn a trade is in the shop itself. As the men in our modern shops are so busy, we cannot trust our beginners to learn from them, so we have selected a competent mechanic for every 25 boys in the shop. He has no other duties than to instruct and look after the apprentices in his care. It is his duty to see that each boy gets a thorough training on each class of work and to arrange for his transfer from one class of work to another. He of course works in harmony with the foreman. Great care should be exercised in selecting these men



Apprentice Band, Atchison, Topeka &amp; Santa Fe

but nothing that will detract him from that vocation. All the instruction in the school room is individual. Each boy progresses according to his ability. We have our own printer and printing press; prepare and print our own lesson sheets, these being issued to the various schools in loose leaf form so that they may be revised or added to as the occasion arises. The following are examples of what the apprentices are taught and some of the problems they are required to solve:

## LESSONS IN LETTER WRITING

37. Write a letter of thanks to some one who has befriended you in some way.
38. Write a letter to the publisher of some railway magazine, ordering the magazine for a year and enclosing remittance for same.
39. Suppose an error was made in figuring your wages for last month. Write a letter to your head timekeeper asking him to investigate, enclosing with your letter statement showing number of hours worked each date.

## INSTRUCTIONS REGARDING MATERIALS.

Wood is commercially divided into two general classes, hard and soft. With the hard woods we class oak, ash, hickory, birch, walnut, maple, etc. The soft woods are pine, poplar, chestnut, birch, etc. Railroads use the following species of wood: Long leaf, loblolly and white pine; spruce, oak, ash poplar, bay wood, mahogany, maple, cherry and walnut. More pine is used than all other kinds combined. Oak is next in quantity.

for much of the success of an apprenticeship system depends upon the instructor. He should not have too many boys under his supervision. His duties are as difficult as they are important and as full of trials and hardships as of blessings for those whom he influences. He must be a keen judge of human nature, a man who is deeply interested in boys and young men, capable of taking a brotherly interest in their sports and pastimes, as well as in their work. He must be clean morally, must be just, impartial, and honest, must be firm and fair, must have patience and ability to instruct, must be able thoroughly to sympathize with each boy in his troubles and ambitions, and hold the friendship and confidence of each one. He must make an individual study of each boy and learn just what help each one needs and how this help can best be given. He must become familiar with each boy's home life, know with whom he associates, and how he spends his evenings, remembering that if the boys are to become good men and loyal mechanics they must also be honest and upright citizens.

*Selection of Apprentices.*—No system will produce results unless good material is selected to start with. So be careful in the selection of your apprentices. Since we are preparing

men for a life-time of service, it is well to start with boys who are sound in body as well as in mind. Each applicant is required to pass an examination before the company surgeon, the examination being very similar to that required of applicants for life insurance. We also give the boys a school examination, the amount of schooling required depending upon the opportunities each boy has had. Of the boy who has had unlimited opportunities we expect much, but with the poor boy who has had to drop out of school to help support his widowed mother or little sisters, we make considerable allowance. In general, however, a boy who has reached the age wherein he may enter upon an apprenticeship, who has not yet learned how to add, subtract, multiply,

set of tools, but these he may purchase at wholesale prices and if he prefers, by monthly deductions from his earnings. We have our apprentice baseball and football teams, our apprentice band and apprentice orchestra, apprentice clubs and social functions. When a man is needed for special duties some young man is selected according to his fitness, and given special training for this particular job. Just now we have several of our machinist and boilermaker graduates taking special training at the Baldwin Locomotive Works; likewise several car men at the shops of the Pullman Company. Just now we are sending some of our men to the Westinghouse shops and some painter graduates to the Pullman shops, the latter to become more familiar with the painting of steel cars, and particularly with the graining of steel work. So it goes. Nothing is too good for these boys who are to be the future journeymen as well as the future officials of the road.

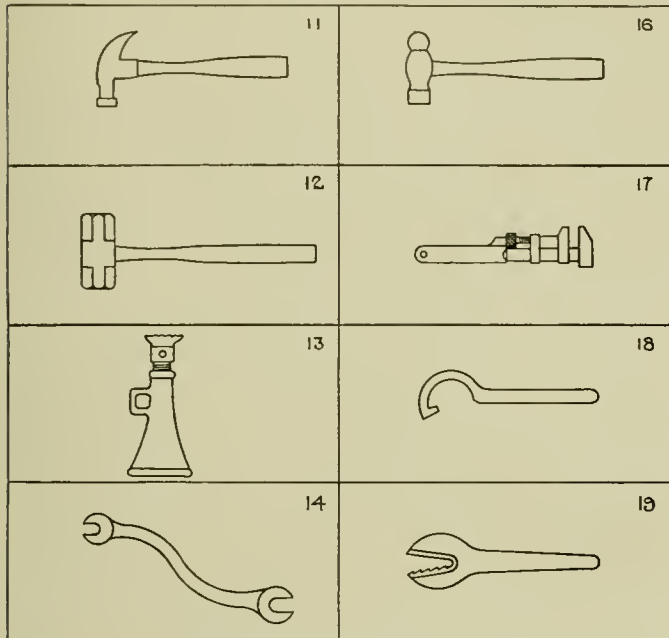

A Sample of the Sketching Required

and divide, and handle simple fractions, is lacking in mentality or at least in ambition. We are also very insistent that no one enters upon work for which he has no natural fitness or liking. It is a crime to hold a boy in work for which he is unfitted, and it is a dead loss to the company to employ such an apprentice. We have plenty of applicants. Each boy employed is a living advertisement for us. When one boy is employed from any community we soon receive a number of additional applications from the same neighborhood.

**Probationary Period.**—Closely allied to the selection of apprentices is our probationary period of six months, during which time each apprentice is given every opportunity to prove his fitness. He is closely studied by our apprentice board which is composed of the general foreman, the department foreman, the gang foreman, the shop apprentice instructors, and the school apprentice instructor. Each month the members of this board are reminded that John Smith is a new apprentice and should be given special attention. At the end of the probationary period the apprentice board meets and jointly passes on the question of this boy's continuing on his trade. Sometimes they recommend his dismissal, other times they recommend an additional trial. If it is found that the boy should be a lawyer or a doctor or a merchant, and is unfitted to become a mechanic, he is kindly told that he is wasting his time in the shop, but the boy knows and his parents know and his friends know and the shop management knows that the partiality or dislike of no one man was responsible for this action.

**Other Features.**—These are the leading features, but there are many details. Each boy is required to have a specified

RESULTS

Does the system pay? It certainly does. It pays in dollars and cents, in the added output of the shop even from the start. It pays much more in the number of skilled journeymen who are being prepared to recruit our depleting ranks. We would no sooner think of doing without our apprenticeship system than we would of doing without our power houses. We have a body of young men who are being thoroughly trained as to the methods in vogue on the Santa Fe and who because of their splendid treatment as apprentices are particularly loyal to the company. The kind and considerate treatment given the apprentices has had a wholesome effect on the entire shop body. The good feeling has been contagious and now permeates the other departments of the

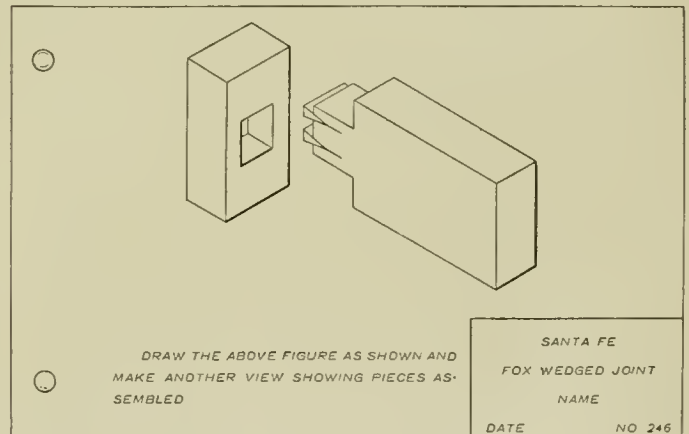

Sample of the Drawing Required

shop. There is less of the old time raw-hiding and more recognition that a man is a man no matter what his position. We have taught our boys that the work of a carpenter is just as honorable as that of a lawyer or doctor, that all the brains of the country are not confined to the halls of congress or to Wall Street. It takes just as smart a man to be a good car man as to be a good merchant or banker. We teach these boys the joy of work, the true happiness of work, and that work is honorable and to be sought, not avoided. We teach them that education will not lessen their work but will increase their opportunities for work and service. All work is sacred.

The principal reason for the success of our apprenticeship system is that it has the unlimited support and backing of the management. Everyone from the president down is proud of the system, and ready to boost it forward. Without such backing it would be hard to install any system of this kind. The average railroad man is too proud of his prerogatives to work in harmony with any system which appears to lessen his authority, and for this reason it is very important, espe-

cially at the start, that the management be back of any scheme which has for its object results which will be more apparent in the future than in the immediate present.

## HANDLING AND REPAIRING FREIGHT CARS

BY F. C. SCHULTZ

Chief Interchange Inspector, Chicago, Illinois

The care of the car, it appears, is governed principally by the demand that there is for the car. This policy prevails generally, although we must confess that it is not the right policy to follow, for in doing so the cars, when the demand is light, are neglected, the repair forces are reduced and the material supplies are allowed to get low. When business picks up again the cars are rushed to the shops, the forces reorganized, inexperienced men are hired, to say nothing of premium prices paid for material which is not always available, for the supply companies follow the same practice and allow their stock to become low on account of the lack of demand. It is claimed that the financial conditions of the railroads require that this policy be followed, but it is apparent that this practice has been changed by some of the strong lines within the last few years. It is now their policy to keep the repair forces at work continuously in order that the equipment will be in serviceable condition when it is required. When business is slack money is cheap and it would be good policy to raise the money at that time to repair the cars so they will be fit to use when business increases.

*Joint Repair Shops at Terminals.*—It is well known that the men in charge of car repairs do not take the proper interest in the repairs made to foreign cars, and this may be justified for the reason that as a general proposition they do not have adequate facilities for making proper repairs to their own equipment. Also they are handicapped in making repairs to foreign cars on account of the lack of the proper material and the fear of making wrong repairs to which the owner of the car may object. This results in cars being allowed to run with defects which should be repaired, and which soon put the car in an unserviceable condition. This is particularly true in a large terminal, and our present method of handling cars under the Car Service Rules is, to a measure, responsible for it. When a defective foreign car is loaded at a terminal, unless it is loaded for the home line, it comes back to the loading point and is continually reloaded until it becomes unserviceable. It is then reported to the car owner and invariably the owner requests that the car be repaired. Many times the car is on a small terminal line, which has no facilities to make the extensive repairs the car may require. For this reason it has been my thought and argument for some time past that at large terminals joint facilities should be created to take care of the foreign cars, not only when they become unserviceable and in a condition to be reported to the car owner, but immediately when they are found to be in need of repairs. Every car foreman would consider it a blessing to be able to send such cars to a joint shop. He could then confine his efforts and resources to repairing his own cars, and far better results would be obtained for all concerned. Car repairers working on a home car will do a more thorough job as they are more familiar with its construction and the material required than they are with the foreign cars. If repairs to foreign cars could be confined to one or more localities in a large terminal, for this reason far better results would be obtained.

Inasmuch as it is the custom to load cars back to the point from whence they came, unless they are loaded home, which is not generally the case, it would appear that by the creation of adequate car repair facilities at large terminals there would automatically be an adequate supply of cars in good condition at such terminals. I have personal knowledge of cars that have stayed in large terminals as long as

two years and nobody heard from them until they got into bad order. The question of joint facilities has been studied sufficiently to satisfy us that it is entirely feasible; and transportation men agree that the per diem and switching charges can be taken care of readily. The question as to whether or not the prices quoted in the M. C. B. rules are adequate to sustain such shops is still open, but if they are not they should be increased so that the repairs to foreign cars can be made profitable to the parties making the repairs. The management of these shops should have authority under the M. C. B. rules to charge the car owner or the delivering line, as the case may be. The repairs should be made and inspected under joint supervision and the bills rendered in accordance with the M. C. B. rules, the switching and per diem charges being rendered against the line responsible for the repairs.

*Routing Foreign Cars Home.*—I wish to call attention to what, in my mind, is a very material defect in our M. C. B. rules. I have in mind the second paragraph of Rule 3, which now states "Empty cars offered in interchange must be accepted if in safe and serviceable condition, the receiving road to be the judge. Owners must receive their own cars, when offered home for repairs, at any point on their line, subject to the provisions of these rules." This rule should be amended so that railroads must receive foreign cars which have home rights over their line, and dispose of them in accordance with M. C. B. rules. This change in the rule is fully justified, especially at large terminals where the points of interchange are anywhere from one to 25 miles apart. It appears that the M. C. B. rules are framed with the thought in mind, that the interchange of cars always takes place upon adjacent tracks. This is not a fact and for this reason the above change should be made. Some car men object to this, saying that if the rules were so changed it would result in neglect to equipment and that the railroads would dump upon each other all such cars after they had become in bad order and expect the home route line to handle them. This is true, and, to my mind, under the present conditions and especially at large terminals, it is fully justified. Further, we should not go to the expense of making technical inspections of empty foreign cars routing home, but should allow them to take the regular course, the same as the home car, and when they reach the trunk line over which they have home rights they should be accepted by that line and disposed of in accordance with the M. C. B. Rules.

Further objection has been raised for fear that cars may be delivered in interchange with penalty defects, or otherwise not safe to handle. This objection is without grounds, for cars with penalty defects are not now being interchanged and the cars that would reach such home route connections would be safe to handle. Of course the cars may require such repairs as ends, roofs and sills which could be made by the home routing line and the car placed in service. From my experience at a large terminal I am unable to justify the return of a car in an opposite direction from home from any point of view, and I hope that at some future time some rule will be formulated which will prohibit this. In event it is, some method of compensating the road required to haul a car in this manner, and which has not enjoyed a loaded haul, should be worked out. I trust that our members in making suggestions for changes in the rules in future will bear this in mind. No rule today that has a penalizing feature is justified. There are sufficient requirements made by the state and federal governments and local authorities to keep the cars in proper condition without resorting to penalties.

*Uniform Interchange Methods.*—In interchanging cars there is also a great deal of variation in the manner in which the M. C. B. Rules are followed, and particularly is this so at large terminals. I can see absolutely no excuse for this,

for a rule that can be worked in one large terminal can be worked in the other. The lack of co-ordination between the committees handling interchange problems at the various interchange points is responsible for this. To remedy this condition I would suggest that one general supervising body be created, whose duty it would be to see that all terminals are operated uniformly. An excellent example of the injustice of the present practice can be seen in the various modifications that are in effect in the handling of loads under A. R. A. Car Service Rule 16. If it is not practical to create one general supervising body it might be well to hold a meeting of the interested parties at the various large terminals each year and adopt a set of rules which will and can be carried out uniformly.

#### M. C. B. BILLING AND REPAIR CARDS

To appreciate the importance of M. C. B. billing in railroad work one must take into consideration the number of cars involved. D. R. MacBain, president of the M. C. B. Association, in his opening address last June, called attention to the fact that the members of the association represented 2,853,482 cars. To give some idea as to the extent cars are off the owner's line, one large railroad owns approximately 5,000 cars more than the average number of cars handled by it, but in spite of this, between 50 and 65 per cent of the cars handled are foreign cars.

There are various methods in which the information for the bills is obtained. Some cars require only very minor repairs, while others require repairs of an extensive nature; therefore one road is very likely to use two different forms on which the original record is taken.

A card form is ordinarily used by one who is termed a repair work inspector to indicate to the repairmen the repairs to be made and provides for such information as the car number, initial, class of car, whether loaded or empty, date, and space for itemizing the repairs to be made and the cause. Often other information is contained on the card, such as the date the car was carded to the repair track, the date and time it was placed on the repair track, the date and time the repairs were completed, and the date and time the car was released for service. After repairs are completed the information as to the kind, size and weight of the material is entered either by the repair work inspector or by one who is termed a material checker. A material checker is very essential in a large organization to insure the proper information being recorded, also to ascertain as to whether or not the repairs are properly chargeable to the owner.

On some roads it appears to be the practice for the repair work inspector or material checker not only to fill in this kind of a card, but to make what is commonly known as an M. C. B. billing repair card; also to make the extensions as to the size of the material, the kind, weight, feet of lumber, etc., and the number of hours chargeable in accordance with the M. C. B. rules. Other roads only require the repair work inspector or material checker to furnish information as to the repairs and the size of material used, and clerks at the shops are required to fill in the billing repair cards, make the extensions as to the weights, number of feet of lumber, hours of labor, etc., chargeable.

Each of these systems has its advantages. The repair work inspector or material checker is more familiar with the car and, therefore, more likely to enter the information correctly; also if he is required to enter the information there will be a tendency to be more careful to see that all the material used is charged, and, as it necessarily involves more direct application of the rules, there is less liability of erroneous charges being made. The advantage in having clerks fill in the billing repair cards, and likewise make the extensions as to the charges under the M. C. B. rules, is that all such men's time would be required to compile the information and they

would become expert, consequently giving a greater output. Also it is the entering wedge for making of the future inspector, foreman, or M. C. B. billing clerk in general offices or accounting departments.

There is still another system in use where all the billing repair cards are properly filled in as to the kind and size of the material used, after which the cards are sent to some central office where clerks make the material and labor extensions and prepare the card preparatory to making out the bill.

After the billing repair cards have been properly filled out and contain the essential information for billing purposes, they are sorted by roads alphabetically. On large roads clerks are assigned to handle certain railroad companies' bills which they render each month. The advantage in this system is that such clerks become more familiar with the initials and class of cars of the various roads for which they prepare bills, and in this way errors are avoided. After the billing repair cards have been prepared and sorted according to roads they are then written up on M. C. B. billing form either in longhand, typewriter or by a special machine which has been constructed for the purpose. The advantage of using machines, where the amount of work warrants, is that after the bill has been written it has also been computed, and there is also much less likelihood of errors being made in extensions.

Two general methods prevail in checking the bills. In one the bills of the foreign roads are checked in the same office that renders the bills, whereas in the other the bills are checked by a different organization entirely. The only advantage the one has over the other is that if clerks are assigned to check bills of the roads for which they have been assigned to render the bill a more uniform manner of billing and checking prevails and the possibility of contentions can be averted, as the billing clerk knows in the preparation of his charge that under the same condition the road against which he is preparing the bill would probably prepare a similar bill.

The best methods to bring about accuracy in making bills are to have a system of surprise checks, either by one delegated exclusively for this purpose, by a division officer when making his periodical visits, or, at the direction of the division master car builder or master mechanic, by having the material checkers or M. C. B. billing clerk at one station check up another station, and report to the head of the department any discrepancies noticed. If either of these practices is followed good results will be obtained.

The work can be facilitated by the least complicated system, but any system is a failure unless it is properly supervised. A man usually adapts himself to a system that prevails at the point where he is employed, and if a bad practice prevails, there is no means of correcting him, whereas if there is a general supervising officer who could devote his entire time to this work, he could harmonize the various practices. He could see that the M. C. B. rules and instructions which are issued from time to time are fully understood and complied with.

The report was signed by J. V. Berg (N. Y. C.), chairman, F. A. Eyman (E. J. & E.), and F. A. Rawley (D. & R. G.).

**HARDENING WITH THE OXY-ACETYLENE TORCH.**—Gear teeth may be hardened by playing the welding flame along the face of a tooth, and then allowing the heat to be conducted away by the body of the gear. The intense heat of the flame permits of a single tooth being heated very rapidly before much heat is conducted to the rest of the gear. As soon as the flame is removed the heat in the treated tooth is conducted away to the body of the gear. This causes hardening of the tooth. This operation is repeated until the desired depth of hardening is reached.—*Welding Engineer.*

# CANADIAN GOVERNMENT SLEEPERS

All-Steel Except Part of the Interior Finish; Cars  
Have 10 Sections and a Weight of 168,500 Lb.

THE Canadian Government Railways have recently placed in service 12 all-steel sleeping cars, eight of which were built by the National Steel Car Company, Hamilton, Ontario, and four by the Preston Car & Coach Company, Preston, Ontario. Each car has 10 sections and two drawing rooms and conforms to the following principal dimensions:

Length over end sills.....	73 ft. 6 in.
Length between truck centers.....	57 ft. 6 in.
Length over buffers.....	82 ft. 6½ in.

The transoms are built up of two 5-16-in. pressed steel web members on each side of the center sills. These are spaced 9 in. apart, and have full length top and cover plates tapering from a width of 24 in. at the center to 15 in. at the ends. The top cover plate is 5/8 in. thick and the bottom plate 7/8 in. thick. A steel filler casting is placed between the center sills above the center plate. In addition to the transoms there are four single-diaphragm cross ties, the webs and fillers of which are 5-16-in. pressed steel, the top

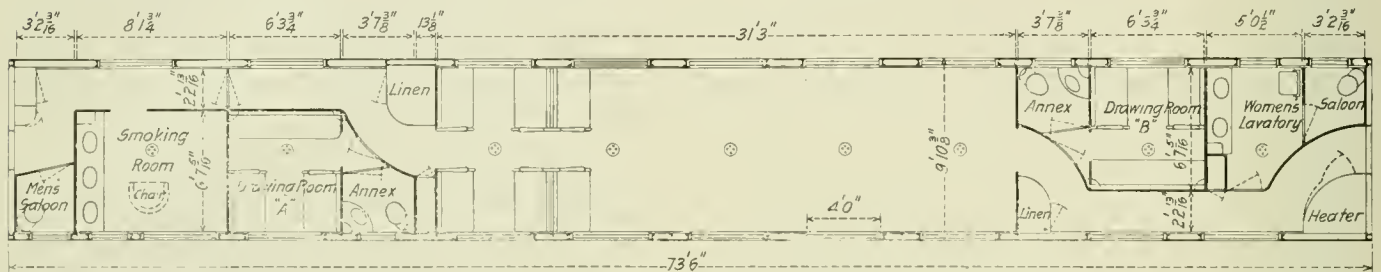

Floor Plan of the Canadian Government Sleepers

Width over side sills.....	9 ft. 10 in.
Height, rail to top at center.....	14 ft. 2 in.
Trucks.....	Simplex, six-wheel
Journals.....	5 in. by 9 in.
Total weight, complete.....	168,500 lb.

## UNDERFRAME

The underframe is of the through center sill type. The sills are 15-in., 40-lb. channels, spaced 16 in. apart, with

and bottom flanges being re-inforced with 3/8-in. and 1/2-in. cover plates, respectively, each 6 in. wide and extending across the car to the 6-in. by 4-in. by 1/2-in. angle side sills.

The body and end sills are 3/8-in. pressed steel, re-inforced at the top by a 1/2-in. plate, 10 in. wide where it crosses the center sills, and tapering to a width of about 3 in. at the end. The platform end sills are made in three sections, the center section being an 8-in. by 8-in., 34-lb. H-beam and the ends built up of structural and pressed steel sections.

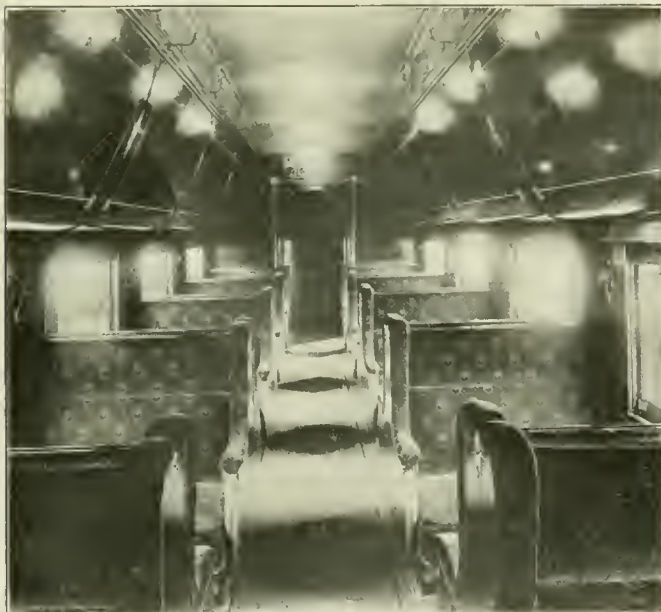

Interior of Canadian Government Sleeping Cars

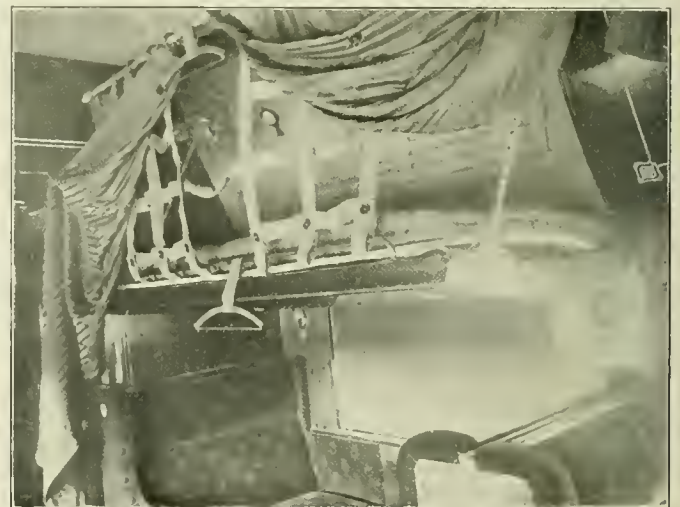

Upper Berth Safety Straps and Coat Hangers

the flanges turned outward and extending from buffer to buffer. A single 3/8-in. cover plate is riveted to the bottom flanges, extending to a point 3 ft. 10 11-16 in. beyond the center line of the transom at each end of the car. The top flanges of the sills are re-inforced with two cover plates, the first a 5-16-in. plate extending the entire length of the sills and the second, a 1/4-in. plate 24 ft. 9 in. long.

Platform end posts of 9-in., 30-lb. I-beams are framed between the sections of the end sills, the attachment to the H-beam being made by means of corner plates of 5-in. by 3-in. by 3/8-in. angles. The intermediate platform sills are 9-in., 13.25-lb. channels, and are attached to the body and platform end sills with 3-in. by 3-in. by 3/8-in. angle corner plates.

The floor supporting system consists of transverse 4-in., 5¼-lb. channels, spaced from 2 ft. to 3 ft. 6 in. apart.











# Shop Practice

## OXY-ACETYLENE WELDING IN BOILER REPAIRS

The Atlantic Coast Line has, to a very large extent, discontinued the practice of riveting fire box seams in locomotive boilers, and instead is welding these seams by the oxy-acetylene process. The only riveting that is done is through

more clearly) and the door sheet is clamped in position. The flanges on the tube and door sheets are flanged cold to a radius of  $\frac{7}{8}$ -in. This work is done in a 250-ton section flange press.

The old firebox is removed by the oxy-acetylene cutting process, and the boiler is lifted from the frames and dropped on to the new box. The mud ring is put in place and the

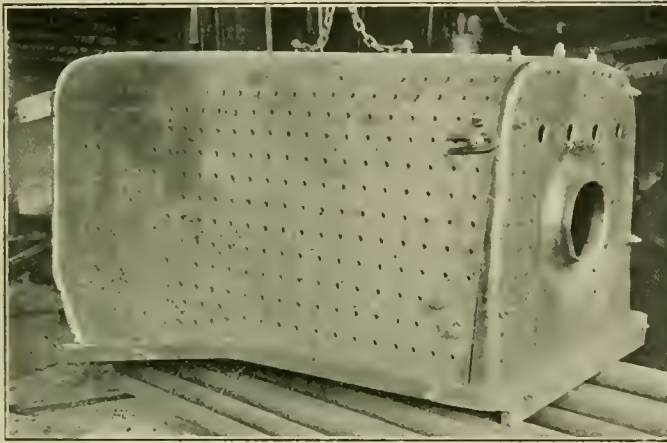

Fig. 1—New Firebox Ready to Be Applied to the Locomotive Boiler

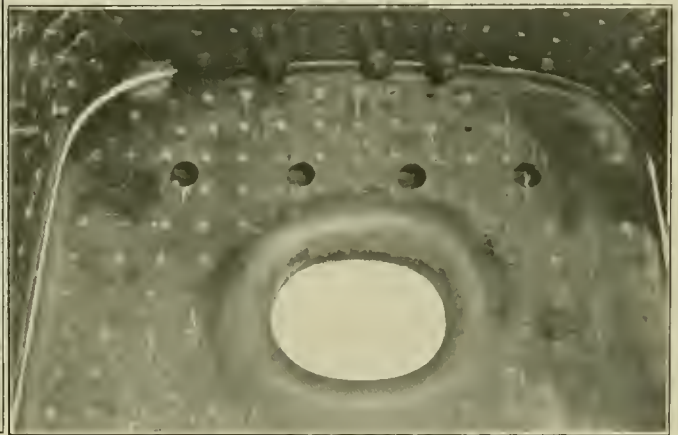

Fig. 2—Door Sheet of New Firebox Partially Welded In

the mud-ring. By following this practice the cost of manufacture and the cost of firebox repairs is materially reduced. The method of applying new fireboxes to wide firebox engines is also greatly simplified. The new firebox is made in three pieces, namely, the side and crown sheet (in one piece), the door sheet and the tube sheet. Four or five new

firebox secured so that the boiler can be replaced on the frames thus giving the other workmen an opportunity for doing their work. The mud ring is riveted in place, the staybolts applied, the door sheet welded in, and the crown bolts applied. Fig. 2 shows the door sheet partially welded in. On the narrow firebox engines the fireboxes are applied

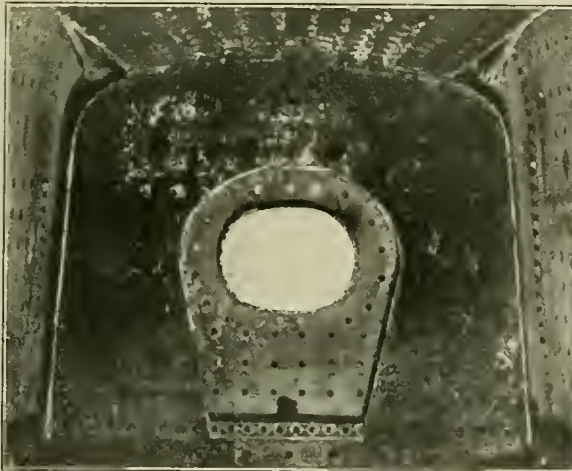

Fig. 3—Firebox to Be Welded by Oxy-Acetylene

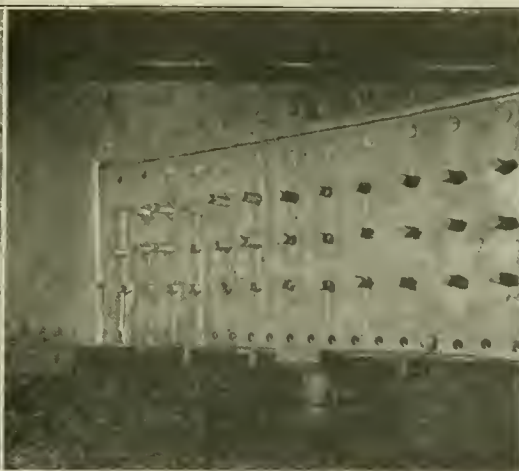

Fig. 4—Side Sheet Patch



Fig. 5—Firebox Corner Weld

fireboxes are made at one time for certain classes of engines and held in stock to be used as needed. This work is all done with templates and the fireboxes are fitted to a standard mud-ring as shown in Fig. 1. The tube sheet is welded in (the weld is painted white in the illustration to bring it out

in five pieces and without removing the back head or the mud ring, and leaving the boiler in position on the frames. These pieces are the two side sheets, the tube sheet, the crown sheet and the door sheet. It will readily be seen that by this practice a large amount of time and labor are saved with an

accompanying decrease in cost. This work has been done in this way for some time and has given very satisfactory results.

In applying patches to the fireboxes the oxy-acetylene welding process has also been found most satisfactory. Fig. 3 shows the interior of a firebox to which new side sheets and a part of a door sheet have been applied. The scrapped sheets were cut out by the oxy-acetylene process. Fig. 4 shows a new lower section of a side sheet in place ready for welding. It will be noticed that the staybolts are applied before the welding is done. Fig. 5 shows a weld in the front

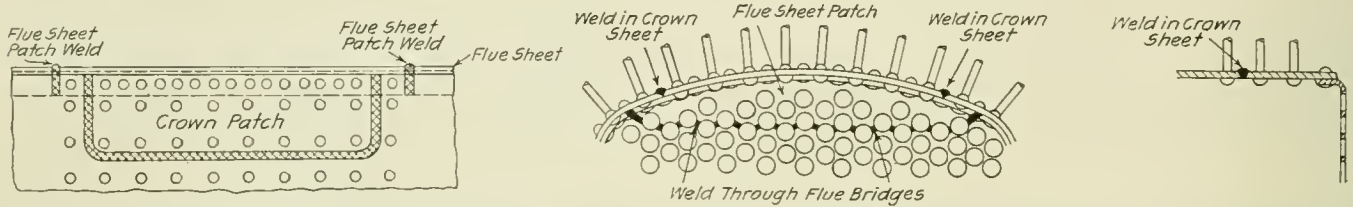

Fig. 6—Crown and Tube Sheet Patch Made by Oxy-Acetylene Welding Process

corner of a firebox between the side and door sheets. In this particular boiler considerable trouble was experienced with the flanges on the door sheet cracking out from the rivet holes. The door, side and crown sheets were cut through at the rivet holes and welded. Fig. 6 illustrates a crown and tube sheet patch made by this method and Fig. 7 shows a front tube sheet which has been partially cut away and is about to be repaired.

While many other roads have used this method of making boiler repairs the practices above described concerning the application of new fireboxes are, at least, unique to a large number. The saving in cost of labor and the reduction in

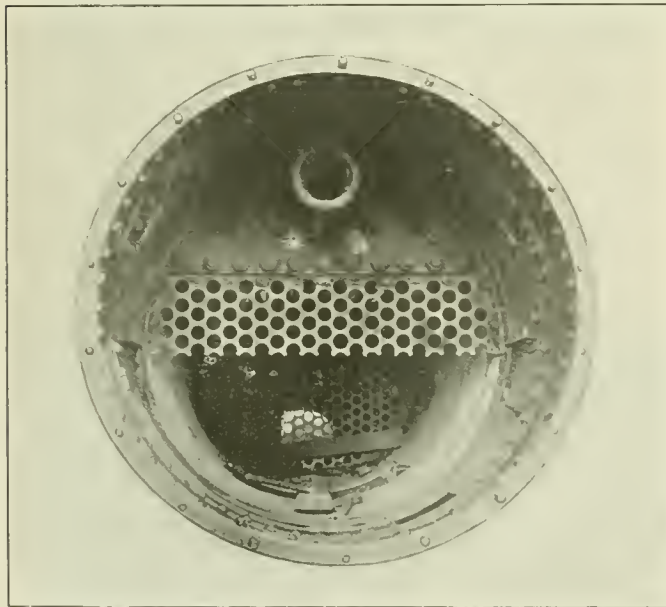

Fig. 7—Tube Sheet to Be Repaired by Oxy-Acetylene Welding

the time an engine is held for such repairs is an attractive feature of this work. The Atlantic Coast Line also welds the tubes in the back tube sheet by the electric welding process. The tubes are set up in the usual manner before they are welded. If leaks occur they are lightly caulked but not rolled. By following this practice a night boiler maker has been eliminated. The information for this article was obtained through the kindness of R. E. Smith, superintendent of motive power; D. M. Pearsall, shop superintendent, and L. M. Stewart, boiler foreman at the Waycross, Ga., shops of the Atlantic Coast Line.

## A LOCOMOTIVE AXLE FAILURE

H. W. Belnap, chief of the division of safety, Interstate Commerce Commission, has recently reported on the locomotive axle failure which occurred on a 10-wheel locomotive on a road in the middle west and which resulted in the death of the engineer. While the locomotive was traveling at a speed of 25 m. p. h. the left main driving wheel came off, stripping the engine on both sides. The engineer was killed by being struck by a broken side rod. The axle failed in the left main journal. In general, the failure was

attributed to poor workmanship in machining the axle, as stated in Mr. Belnap's summary of the report which follows:

"The evidence presented in the investigation of the failure of the axle under engine No. 1056 conclusively shows that the workmanship in machining the axle was the prime cause of its failure. There was an area of metal on the surface of the journal which showed short and numerous cracks clearly attributable to the roughing cut taken in the lathe, the effects of which did not turn out in the finishing cut. These surface cracks afforded the opportunity required for such a concentration of stress as led to ultimate failure. The location of the place of rupture was an unusual one, being near the middle of the length of the journal, where the stresses in service would not ordinarily attain their maximum intensity. The presence of the surface cracks explains why rupture occurred at this unusual place.

"It further appears in the investigation conducted by the engineer-physicist that other fractures were in progress which eventually would have resulted in the failure of the axle. These additional fractures were located in the metal of the wheel seat, on the left-hand end of the axle. While the length of the hub of the driving wheel was 8 in. the length of bearing which it had on the axle ranged from only  $\frac{1}{2}$  in. to  $1\frac{3}{4}$  in. The starting of incipient cracks in the wheel seat was doubtless influenced by this imperfect fit. An error was made in laying out the keyways, and two groups of holes were drilled and plugged in consequence. All of this evidence is derogatory to the class of workmanship needed in an axle. These facts concerning workmanship, however, would not be known after the engine had been assembled and put out on the road, but which nevertheless were the precursors of its ultimate failure.

"The quality of the steel of which the axle was made is not held responsible for the failure. Its examination, apart from the defects due to workmanship for which the metal itself was in no wise responsible, showed no connection between its failure and the quality of the steel. Its structural condition as regards initial strains showed a state of repose and comparative freedom from strains of magnitude in greater degree than the heat-treated axle which was examined, in quest of correlated data, in conjunction with it.

"Primarily, inspection should be made in the shop and assurance of good workmanship received before an axle is in the first place assembled in an engine; and in view of the grave consequences which sometimes follow and are likely at all times to follow the failure of an axle, any indication of a defective condition should be fully explored and the cause of such trouble ascertained before further movements of an engine are made, and those movements which are es-

essential to get the engine to a place of repair should be made with caution:

"There was warning given of impending failure when the engine was removed from the passenger train which it was hauling and replaced by another engine. Trouble was located in the oil-box cellar, but search was not continued sufficiently to ascertain why there was trouble with the cellar. The functions of the oil-box cellar are such that the real seat of trouble should be looked for in other parts of the mechanism, and the inspection not confined to the cellar alone. Had the inspection been more thorough and complete, it is probable that the real trouble would have been discovered and the accident averted, notwithstanding the defective workmanship which was shown to have existed."

### RACK FOR STORING SMOKE BOX FRONT ENDS

BY JOHN H. NAGLE

Chief Draftsman, Buffalo, Rochester & Pittsburgh, Du Bois, Pa.

More or less trouble has been experienced in locomotive erecting shops when storing smoke box front ends after they are removed from the engines. After they are removed they are allowed to stand around the shop and if not properly supported they may fall and be broken, or may injure employees.

To avoid this the Buffalo, Rochester & Pittsburgh has designed a very neat and inexpensive rack for the storing of front ends when not in use. The racks shown by the illustrations are formed of a series of loops which stand in an

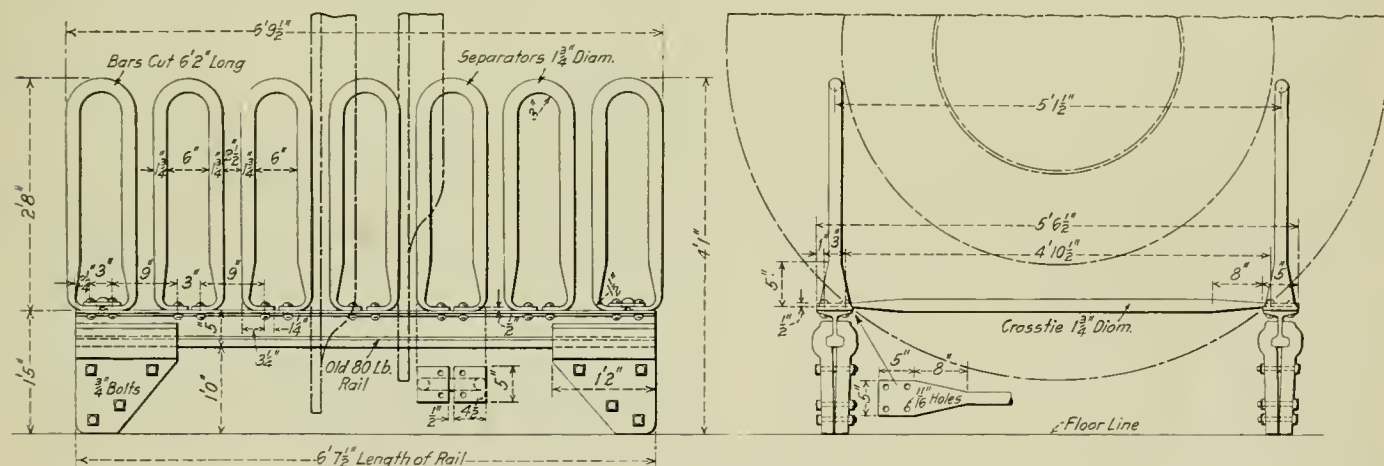

A Convenient Rack for Storing Smoke Box Fronts

upright position, spaced 2 1/2 in. apart, which is far enough to allow a crane to handle the fronts. The uprights are formed of old 1 3/4-in. truss rods removed from gondola cars to which steel underframes have been applied. The carrying members are old 80-lb. rails and the supports are standard cast iron rail stops. The crossies are also made of old truss rods. The smaller rack is for front ends from 56 1/2-in. in diameter to 66 1/2-in. in diameter and the larger rack for front ends 70 1/2-in. in diameter to 91 3/4-in. in diameter. These racks are now in use at our various shops and have proved very satisfactory.

**MIXTURE FOR PREVENTING SCALING OF STATIONARY BOILERS.**—A mixture for preventing scale in boilers, consisting of graphite and caustic soda in the proportion of 50 oz. to 30 lb., has been found effective, it is said, by the chief engineer of a private plant operating two 260-hp. B. & W. boilers. The boilers are treated alternately, the mixture being fed gradually to one boiler, and during that time it is not blown down. The other unit, however, is blown down every morning.—*Power.*

### WHY HAVE AN APPRENTICE SCHOOL?

BY A. B. KERR

Apprentice Instructor, St. Louis & San Francisco, Springfield, Mo.

A blacksmith was vigorously protesting against the educational qualifications which barred his son from starting an apprenticeship. He claimed that one did not need an education in order to learn the trade—in fact, the real reason why he wanted his boy put on was because he did not make much progress in the public school. Now, this blacksmith was accounted a very good mechanic; he wasted scarcely any iron, his welding performance was somewhere close to 100 per cent, his heats were always neat and just about right. He was not a cut-and-try mechanic. He could not tell you just how he did secure results, but he got them just the same.

Shortly after this conversation the blacksmith was asked by an apprentice who was under instruction, why it was that too much draft in a fire was not a good thing for a welding heat. No answer was forthcoming. When after the next class period the apprentice explained the reason of scale or oxidation, he was submitted to much chaffing. Why, that was plumb theory; it was worse than that, it was c-h-e-m-i-s-t-r-y, a science, a study for long gray beards who puttered around and did little real work. This was a blacksmith shop where they were paid to get out the work.

This may appear to be exaggerated, but it is an example of what is occurring in most shops—not blacksmith shops alone, but all manner of shops. It is what has happened, what is happening and what will happen; it is the inevitable condition which surrounds progress. Progress may be called

the pathway formed by practice following in the footsteps of theory; for no matter what the practice, a theory had first to be formed, a plan made before the action could take place.

To all mankind theory gives one common boon—the ability to think after a logical and conclusive manner. Since speech is an expressed thought, then, in order to speak knowingly, one must first be able to think coherently. Take the blacksmith, for an example; he could talk all around any fine point of his trade, yet he could not explain these points—he did not know the why.

Time was when a man was allowed to learn a trade or a business by personally practicing all its details; if asked to do a piece of work he had never done before, he had a satisfactory answer ready—he had never done it. Now, however, and it is becoming more so each day, men are called upon to do work that they have perhaps never heard of, and in a way they are expected to make good. Slotter, shaper and planer work, while performed on three separate and distinctly different machines, is yet of the same nature; few mechanics have experience on all three, but they are expected to be able to successfully do work on all of them. If one had first to per-

form all possible sums of addition before feeling proficient it would, indeed, be a hopeless task. We know that as quickly as the principle of addition is learned, it is all learned. The theory of anything is nothing more nor less than the principle of the thing, and once the principle is understood, the rest is but a case of applying what one already knows. Principle must be known, else each new job is as sailing over uncharted seas. Had the blacksmith known the theory of scale formation, he could have thought out the answer to the apprentice's question, even though it might have never before presented itself.

Furthermore, one theory or principle generally presents another, and this fact promotes more or less comprehensive reading and argument. It suggests and abets the exchange of ideas; it stimulates "shop talk," a desirable thing. The study and knowledge of a theory, then, promotes thinking; not dreaming, guessing or speculation, but thinking, the kind of thinking that requires effort and training.

Efficiency depends on sound common sense, upon basic principles followed out in a logical and a conclusive manner. Some schemes of efficiency have failed, others have been of pronounced success. There is generally a pretty fine line between a true failure and an honest success, and good sound practical judgment is always the line. Is it possible to make an efficient mechanic of a man who does not know the rudiments, the principles of his craft? If so, is he not like a nicely balanced boat fully laden and floating serenely, but if tipped even the slightest it will immediately sink out of sight? A man is not efficient if he is liable to capsize when any little irregularity presents itself; he is neither self-reliant nor resourceful, two quite important characteristics.

All men, and especially the younger ones, such as apprentices, junior clerks, etc., should be taught principle. They should not be put doing anything, or at least rarely, unless the theory or the true meaning of the work is first explained to them. First, because the employee is then in a better mood, cheerfully and intelligently, to perform the task. Second, because the employee is in training better to know the detailed demands of the business, to gain some idea of possible improvements or extensions of the business. Third, because the employer is so truly educating his men that they grow

## DRIFT FOR TRUING UP SUPPLY VALVE STEM GUIDES

BY F. W. BENTLEY, JR.

The supply valve stem guides in the supply valve caps of Westinghouse air signal reducing valves are frequently found bent; that is they are not true with the rest of the cap and

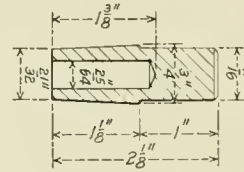

The Drift and Its Application to the Valve Stem Guide in the Cap

often to such an extent that the valve below will be forced to tip and overcharge the signal line. This condition results from a number of causes, such as working a dirty valve free in its bushing seat, trying to apply the valve cap without cutting out the cock, and a few other things that a careful man would not attempt. The sketch and photograph show details of a handy centering drift with which the guide can be quickly drawn into place. Both in the shop and round-house it will be found very convenient and worth the time taken to turn it up.

## UNION PACIFIC METHOD OF FACING DRIVING BOX SHOE AND WEDGE FACES

The reclaiming of worn driving boxes by lining in the wedge and shoe faces with bronze has been quite extensively practiced on the Union Pacific, and greatly increases the length of service obtained from these boxes.

The method of applying the bronze is shown in detail in the drawing, the bronze being cast on the box and then machined to proper dimensions. Holes are drilled for 1 3/8-in. plugs, those at the top and bottom passing through the shell, and grooves are cut at the corners of the flanges to fur-

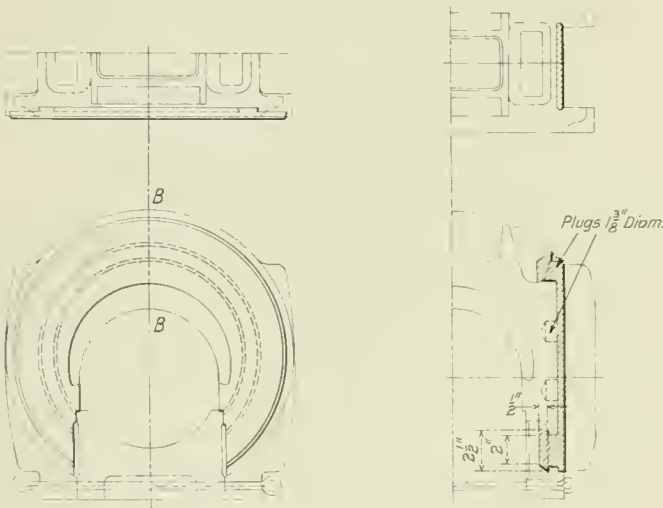

Note: Holes for Plugs are Drilled 1 3/8" Diam. taking care, in case of Central Four Holes, not to Drill Through Shell Cut Grooves in Side Flanges of Shoe Fit to Further Secure Liner. Box is then Leveled up and Strips for Holding Metal at Ends, put in place. After Head Formers for Through Plugs are put in position Box is ready for Pouring, but must first be Heated.

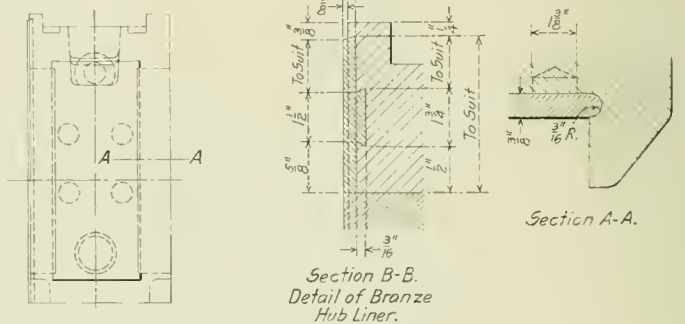

Details of Method of Reclaiming Worn Driving Boxes on the Union Pacific

in self-reliance, resourcefulness and progressiveness. To any honest, aboveboard business there never has been any danger from education.

It is submitted that the desirable mechanic is the one who not only can do a particular piece of work, but knows how and can tell the other fellow.

ther secure the liners. In pouring, special head formers are used in connection with the top and bottom holes, the heads securely holding the metal to the box.

The use of bronze for hub wearing faces has also resulted in a longer period between repairs, as the lateral motion does not increase as rapidly as with the usual babbitt facing.

# OPERATION OF A GENERAL FLUE SHOP\*

Description of Atlantic Coast Line Methods and Equipment. Safe Ends Are Electrically Welded

BY R. B. VAN WORMER

General Foreman, Atlantic Coast Line, Waycross, Ga.

WORK in the flue shop is practically a continuous operation, and the shop should be laid out with that end in view. The more continuous and rapid the work is performed the smaller the number of tubes it will be necessary to hold in stock. The tube cleaner should be located at the main entrance of the flue shop. The track facilities should be such that the second-hand tubes sent to the shop for safe-ending can be unloaded conveniently from the car to the cleaner. Similarly, suitable track facilities are necessary at the point where the tubes come out of the shop ready for service so that they may be conveniently and promptly shipped without delay. The accompanying diagram shows the general arrangement of the apparatus and track connections at the Waycross, Ga., shops of the Atlantic Coast Line. This flue shop is located in an ell or corner of the main shop building, and occupies a space 40 ft. wide by about 90 ft. long. A 10-ton overhead crane from another department beyond is used in this shop a small part of the time. All of the

overhead crane and stored adjacent to the tracks as shown. About 500 new tubes per month are handled at this shop. All second-hand tubes are received with their firebox ends heading into the shop and at this general shop the arrangement is such that the tubes are removed from the boiler and replaced without being turned end for end.

## SHOP EQUIPMENT

*Flue Cleaner.*—The flue cleaner is the Ryerson overhead type, with suspended case-hardened chains. It will handle 500 2-in. tubes, 24 ft. long and at one time. This machine is driven by a 20-hp. motor and it raises and lowers the tubes into the pit by its own power. It may be loaded and started in less than 15 minutes, and unloaded onto the flue car in the same length of time.

*Flue Cutter.*—The flue cutter *B* is home-made and very simple in construction, consisting of a 4-ft. shaft secured at one end in a swivel bearing. The other end carries the disc cutter which is secured in a bearing carried on a screw, permitting the cutter to be fed down by hand. The shaft with the cutter is driven by a 2-hp. motor connected with the shaft by a silent chain for the necessary flexibility. This machine will cut off a cold tube in 7 to 10 seconds after it has been placed in the machine.

*Safe End Machine.*—The safe ends are made on a McGrath safe end cutting-off machine located at *A*. This machine is designed to automatically and correctly cut off safe ends to the various lengths for which it is set, and is so arranged that either stock or scrap tubing can be used. The machine also automatically scarfs the safe ends, but for electric welding this feature is unnecessary, since both the tube and safe end should be cut off square.

*Electric Welder.*—The safe ends are welded to the tubes by an electric welding machine made by the Thomson Welding Machine Company. This machine operates on a single phase, 60 cycle, alternating current at 440 volts. This voltage, however, is stepped down to 4 to 6 volts and with a current of 4,400 amperes requires about 22 kw. About 45 tubes per hour can be welded. The machine contains a break switch operated by foot treadle and another switch tapping the primary coil so that the current can be varied for different gages of tubes. On the top of the machine are two sets of quick-acting, water-cooled, bronze clamps, one for the tube and the other for the safe end. The safe end clamps are connected to a 5-ton double-acting oil jack operated by a convenient lever, which is used to force the safe end against the tube during the welding. The clamps are connected directly to the terminals of the secondary coil of the transformer. The entire surface of the tubes is gripped by the clamps so that the current will enter the tubes throughout their circumference. In operating this machine the tube and safe end are dropped into their respective dies and clamped; the switch is closed by the foot treadle; the tube and safe end begin to heat up instantly at their abutting ends in full view of the operator and when at a welding heat they are forced together by the jack, and at the same time the treadled switch is opened. The tube is then removed, having a thorough, sound but re-inforced or enlarged weld due to forcing the safe end against the tube. With this method of welding best results are obtained by using safe ends of the same thickness as the tubes. With the practice of welding the tubes

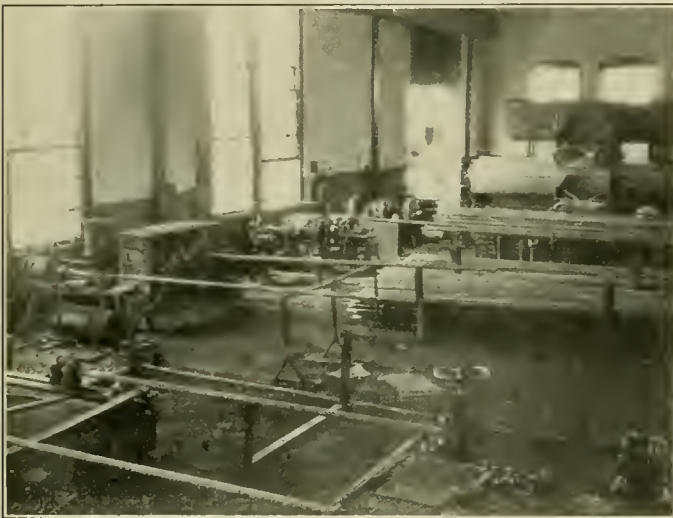

Flue Shop at the Waycross, Ga., Shops of the Atlantic Coast Line

apparatus in the shop has individual motor drive, thus no belts or overhead shafting is required. The figures 1, 2, 3, 4 and 5 in the shop layout show the various stations of the workmen performing the consecutive operations. The letters designate the equipment, storage space and tracks.

The flue cleaner is located just outside the shop on the standard gage track running through the end of the flue shop and is designated as track *Y*. There is also another standard gage track marked *X*, passing through the building at the other end of the flue shop. The track *Z* is a run-around track common to all of the shops. The second-hand tubes shipped in from outlying points may be unloaded either directly from a car on track *Z* at *W*, into the cleaner, or, if they are received in an open car, from track *V*, they being picked up with a crane and special slings provided for the purpose and loaded onto a special tube car and delivered to the cleaner. By the later method the tubes can be unloaded, placed in the cleaner and the cleaner started in not more than 15 minutes. The new tubes are received on track *X*, unloaded with an

\*Abstract of a paper presented to the Southern & Southwestern Railway Club.

into the back tube sheet this is not a disadvantage, since the tubes are not worked to the extent, while in service, that they are when not welded. On the other hand, there is a distinct advantage in using safe ends and tubes of the same gage, as a large saving may be made in the purchase of new safe ends of the same gage as the tubes. By thus welding safe ends, sound, reliable welds are obtained, a welding furnace is eliminated, the outfit is compact, clean and comfortable for the workmen to handle and safe ends of any length can be welded. An interesting feature in connection with this machine is that it refuses to weld tubes that have become too thin, as the tube will burn before the standard safe end has reached a welding heat. This characteristic of the machine in no way interferes with successful welding where the difference in thickness is within reasonable and practicable limits.

**Grinding.**—For obtaining perfect and quick welds, it is necessary that the tube and safe end be clean and free from scale or rust where they are clamped in the copper electrode lining of the clamps. This is best accomplished by a slight grinding or polishing around the tube for about 2 in. in length. This is done on an emery wheel, for which purpose the double grinder *C* is provided; one wheel is used for the tube, and the other for the safe ends. As the safe ends are ground they are placed in the storage rack *D* convenient to the electric welder. The ground tubes are placed on suitable supporting rails at a convenient height for the machine. These rails extend across and serve the grinder, the welder and the roller.

**Rolling Machine.**—The rolling machine is located at *F*. It can be of several different designs, but it should be such that it will roll down both the inside and outside of the tube to its nominal size. An old Hartz flue welder can be used by boring out the spindle or main shaft carrying the rollers,

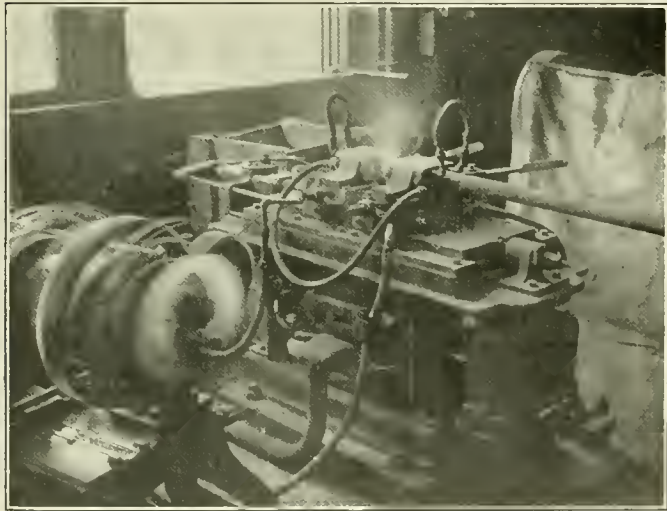

Machine for Welding Tube Safe Ends

together with a sufficiently long mandrel within this shaft to take a safe end 4 ft. in length.

**Swedging Machine.**—The swedging machine *H* consists simply of two air cylinders, one horizontal and one vertical. The vertical cylinder operates a clamp to hold the tube, and the horizontal cylinder shoves the die over the heated end. The two cylinders are operated by one foot-operated air supply valve conveniently located. Check valves with a small port drilled through each valve, are placed in the pipes leading to each of the cylinders. The valve in the die cylinder connection opens away from the cylinder while the valve in the clamp cylinder opens toward that cylinder. With this arrangement the clamp will be applied two or three seconds ahead of the die and it will be released two or three

seconds later than the die. This machine will readily swedge 150 tubes per hour.

**Flue Cutter for Cutting to Length.**—The flue cutting machine *J* which cuts the tubes to exact length, is identical in design to the machine *B* except that a suitable stop for the tube has been added. This stop is adjustable, and can be set for any length desired. This machine is also equipped with a die or plate enclosing the swedged end of the tube in such a manner as to grind and smooth up the swedged end while the other end is being cut off. This arrangement eliminates any filing or preparation on the swedged end for setting the tube in the boiler. This machine is so located that the tube does not have to be turned end for end. Its capacity is 120 tubes per hour.

**Annealing.**—As fast as the tubes are cut to length, the smoke-box ends are placed in the annealing furnace *K* and

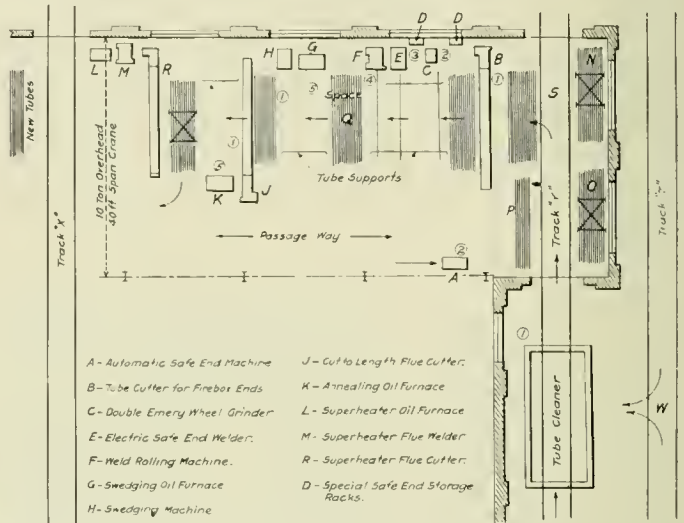

Layout of the Flue Shop

- A - Automatic Safe End Machine
- B - Tube Cutter for Firebox Ends
- C - Double Emery Wheel Grinder
- E - Electric Safe End Welder
- F - Weld Rolling Machine
- G - Swedging Oil Furnace
- H - Swedging Machine
- J - Cut to Length Flue Cutter
- K - Annealing Oil Furnace
- L - Superheater Oil Furnace
- M - Superheater Flue Welder
- R - Superheater Flue Cutter
- D - Special Safe End Storage Racks

from these they are placed on the tube car. The rate of annealing is governed by the rate of cutting to length, as these two operations are carried on together.

SHOP ORGANIZATION

Inasmuch as the output of the entire flue shop is controlled by the output of the electric welding machine *E*, the operator of that machine, man No. 3, is held responsible for the output of the shop and is considered the head workman. The following is the route of the tubes through the shop and the duties of the five men connected with it:

After the tubes have been cleaned they are moved to the point *S* in the shop where they are gently unloaded by an overhead crane onto the floor between the track and flue cutter *B*. At this point man No. 1, who also operates the flue cleaner, cuts off the firebox ends of the tubes on flue cutter *B*, after which the tubes are rolled over onto the floor between the cutter *B* and the double grinder *C*. As each tube is cut off, it is inspected by man No. 1 for thinness and pitting. This inspection is closely followed and checked by both the boiler foreman and the chief inspector, and the condition of the tube determines the class of service in which it will be used. If any pitted tubes are found, those that are not too badly pitted and which may be reclaimed are set aside and the pits are filled in by welding in the space marked *P*. The scrapped tubes are set just outside the door near the track *Y*, where they are loaded once each week and sent to the scrap yard.

Man No. 2 grinds the tubes after they have been cut off and rolls them over on rail supports to the electric welding operator, No. 3. The rail supports between the grinder and welder should provide for not less than 30 ground tubes



at a time. As the tubes and safe ends can be ground at the rate of 90 and 120, respectively, per hour, which is twice as fast as they can be welded, the same grinding operator, No. 2, also is assigned to take care of the operation of the automatic safe end machine A.

The welding operator passes the welded tubes on to man No. 4 who rolls them down to size. They are then piled at Q, between the roller F and the swedging furnace G. Sufficient space should be provided at Q to permit storing 2 sets of tubes, so that new tubes which require no welding can be brought from their storage space F, heated, swedged, cut and annealed, without interfering with the continual operations performed on the second-hand tubes. This will be possible, as the heating, swedging, cutting to length and annealing is done at an average rate of 120 per hour. Second-hand tubes are sometimes taken from this pile and shipped to outlying points that swedge and out their own tubes. Such tubes usually are placed in special slings, so that they may readily be picked up, a set at a time, and loaded directly on a flat car at the tracks Y or X by the overhead crane without further handling or storing. Again there are cases, with some old engines, where it is necessary to wait until a new firebox or tube sheet has been applied before the proper length of tube is determined. In this case the tubes, after being welded and rolled, are loaded in a flue car at this space Q, and the car placed out of the way at the storage space N by the overhead crane without unloading. Then when the tube lengths are obtained, the car is returned to the space Q, and the tubes given their final operations without any interference or interruption in the other work.

Man No. 5 takes the tubes from the space Q and heats them in the oil furnace G, passing them over onto the supporting rails to man No. 1 who is now operating swedging machine H. The oil furnace G should be large enough to take not less than 8 tubes at a time, which will allow heating at the rate of 120 per hour. The tubes as swedged by man No. 1 are piled on the floor or a flue car to cool in the space between the swedging machine and flue cutter J. This space should accommodate not less than one complete set. When a whole set is loaded in a flue car, it is ready to be sent to the engine, or if the repairs to the boiler are not yet sufficiently advanced for the tubes, the flue car with the tubes can be temporarily stored out of the way at the end of the flue shop at space O, where they may be tiered three and four cars high by the overhead crane.

**Superheater Flues.**—The superheater flues are handled at the extreme end of the shop, all cutting off being done on the cutter R. They are heated in the oil furnace L, and welded on the Hartz welder M. This is of the usual type, equipped complete with mandrels and formers for welding flues up to 5 3/8 in. in diameter. It is driven by a 5-hp. motor.

DISTRIBUTION OF WORK

The distribution of the work is such that when the shop is working to maximum capacity no one man is overworked and man No. 5 will have about one hour per day, which he devotes to cleaning up the shop, distributing safe ends, loading scrap tubes, oiling machines, etc. The labor for the flue shop, based upon the maximum output of 450 second-hand flues in 10 hours, is as follows:

Cleaning .....	1/2 hour	Man No. 1
Inspecting and cutting firebox ends.....	7 1/2 hours	Man No. 1
Grinding body flues.....	5 hours	Man No. 2
Grinding safe ends.....	3 3/4 hours	Man No. 2
Welding .....	10 hours	Man No. 3
Rolling .....	10 hours	Man No. 4
Heating for swedging.....	3 3/4 hours	Man No. 5
Swedging .....	3 3/4 hours	Man No. 1
Cutting to length.....	3 3/4 hours	Man No. 1
Annealing and loading.....	3 3/4 hours	Man No. 5
Transportation to and from the flue shop, estimated .....	15 cents	

It is the practice at this shop to weld the tubes into the back tube sheet. The tubes are applied in the customary manner before welding. The cost of welding is about 21 per

cent of the total cost of the work done on the tube from service back to service. This is comparatively high, but it is fully justified by the saving effected in the cost of running repairs on tubes, as well as in the reduction of engine failures from tubes leaking in service.

BOILER STEEL CYLINDER PATCH

BY W. P. HOBSON

Master Mechanic, Chesapeake & Ohio Railway, Covington, Ky.

During the past several months three of the superheater Mikado type locomotives handled at Huntington have developed cracks in the cylinders. It was either necessary to apply a permanent patch or renew the cylinders. As applying new cylinders is quite a costly job, we undertook the application of boiler steel patches. The service of these patches so far has been entirely successful and the indications are that the job is a permanent one.

The photograph shows clearly how the patching was done

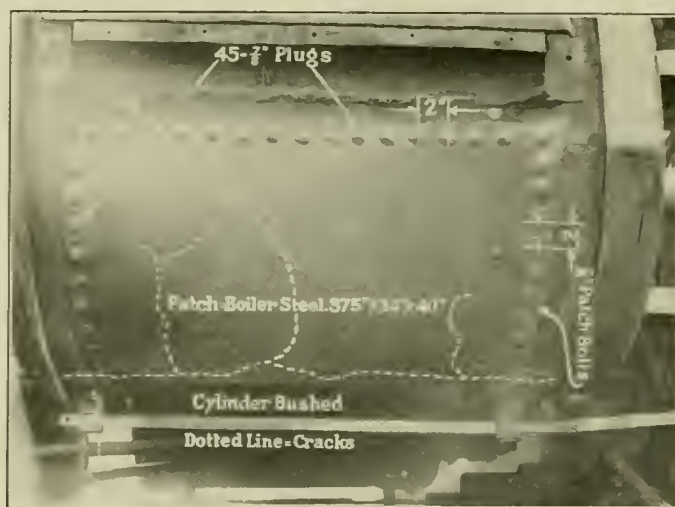

Method of Applying Boiler Steel Patch to Cylinder

on one of the locomotives. The cost of labor and material in applying the patches to the three locomotives averaged \$25.65. When compared with the cost of applying new cylinders, it will be seen that this method of repairs was well worth trying.

PNEUMATIC CLAMPING AND HOLDING-ON DEVICES

BY FRANK J. BORER

Foreman, Air Brake Dept., Central Railroad of New Jersey, Elizabethport, N. J.

The two sketches show simple devices which we find very useful. They can be made up at a small expense at almost any shop.

The pneumatic clamping device for use on a drilling machine saves a good deal of labor and prevents the breaking of drills due to poor clamping or holding of the part being drilled. This was originally constructed for holding air hose couplings while drilling out broken stop pins, but it was found to be equally useful when drilling bolts, pins, plates and various kinds of passenger car trimmings. We use it in connection with the regular shop air pressure, which is 100 lb., giving a pressure of about 960 lb. at the piston. When not needed, or if in the way of large pieces which are to be drilled, the device can easily be detached from the drill table in a few seconds. The piece of 3/8-in. tee iron at the lower end of the cylinder piston rod can be made of any length or shape to suit the class of work to be drilled. When drilling round parts such as rods, etc., a pair of small "V"



allow him to handle the tools himself. In this way he will gain confidence and learn kinks that it would take him a long time to pick up otherwise.

Before starting a man on the job of taking out and renewing broken staybolts explain to him that the threads on opposite ends of new staybolts should check inch for inch at the top. Otherwise when he puts in a staybolt that is half a thread out, the bolt as it enters the opposite plate will force the thread off its base and in a few trips the staybolt will be leaking and have to be hammered up. It is then only a straight piece of round iron with about a 3-16-in. metal head and will leak continually. This will give the boiler a very untidy appearance. For some reason or other these threadless bolts are nearly always found in most inaccessible places, such as behind eccentrics or feed pipes.

Show a young man that by using his brains he can order his machine and blacksmith work ahead and double the amount of work he can do. The mechanic who sends his helper for bolts or taps and when he brings them, sends him back again for wrenches to fit them, does not get along very fast.

You may start an apprentice putting on a flanged patch some day and he will drill all the holes before he gets it fitted, iron to iron. Some of the holes will be 1/4 in. out. Do not let him fill these with rivets, but make him throw the patch away and do the job over again. Next time he will not even try to fit the patch that way.

A foreman boilermaker having young men under him learning the trade should be just as careful to see that he is turning out good mechanics as that he is turning out good boiler work. I would not encourage a son of mine to learn the boiler trade. It is dangerous, it will make you deaf and will ruin your disposition. However, there always seem to be young men willing to learn the trade. Unless you make good mechanics out of them, you are turning them into tramps, for they will be continually going from place to place looking for work because they did not learn the trade right in the first place.

**EFFECT OF SULPHUR IN RIVET STEEL\***

BY J. S. UNGER

Manager, Central Research Bureau, Carnegie Steel Co.

Sulphur in steel, whether justly or unjustly, is held responsible for the bad working of steel. As a result the specifications covering the allowable amount of this element have been gradually lowered, until in certain cases below .030 per cent is the limit demanded. It is very difficult to reach this limit, and when reached there are grave doubts in the minds of many whether the quality of the steel has not suffered by the excessive purification required.

It is almost the universal practice, when steel shows a tendency to work badly or becomes red short, to make an analysis of the steel. If this analysis indicates that the steel has the proper or permissible amounts of the usual elements, but happens to be a few thousandths of a per cent higher than the specified amount of sulphur, the sulphur is held responsible for the trouble. Such decisions are made without considering any other influences, such as the heating for rolling or the subsequent heatings necessary to work the material up into a finished product. Very few users of steel appear to have either the time or inclination to make a few trials at slightly higher or lower temperatures in manufacturing their particular product, to determine if they are using the temperature at which the iron will work the best. The argument usually presented by them is that the greater part of their steel works satisfactorily with their shop methods, and they should always receive steel of the same quality. There is a certain amount of justice in the argument, but sometimes it is based on an opinion which does

not include all the factors in the case. At least four factors influence the results: No two heats of steel are exactly alike; no two users of steel use exactly the same methods in fabricating the finished product; no two operators in the same shop work exactly alike, and the same material may work well at one time and unsatisfactorily at another, in the same shop.

The purpose of the experiments described was to study



Fig. 1—Results of Hot and Cold Bending and Flattening Tests

the effect on the working and physical properties of rivet steel by gradually increasing the amount of sulphur in the steel, until it had been raised to a point far above that usually found in such steel.

The steel used was regular basic open hearth of carbon .09 per cent; manganese, .43 per cent; phosphorus, .012 per

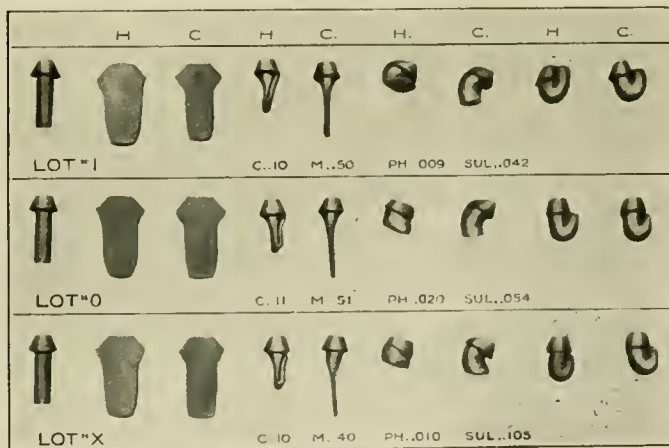

Fig. 2—Hot and Cold Forging Tests

cent; sulphur, .031 per cent. The sulphur content of certain ingots from this heat was increased progressively by adding weighed quantities of sulphur, the additions being regulated to secure as near as possible a uniform increase of sulphur from one ingot to the next higher. The heating and rolling was done in the regular way and all ingots were treated exactly alike. The finished 3/4-in. diameter rounds were alike in every particular as regards composition, heating and

\*From a paper read before the American Boiler Manufacturers' Association.

rolling, excepting that they carried different amounts of sulphur. The rolled bars showed the following amounts of sulphur: .03 per cent, .06 per cent, .09 per cent, .14 per cent and .18 per cent.

The hot working properties and some of the cold working properties are shown in Fig. 1. In Fig. 2 are shown some tests made on three separate heats of steel with different sulphur contents. A study of the appearance of the tests shows

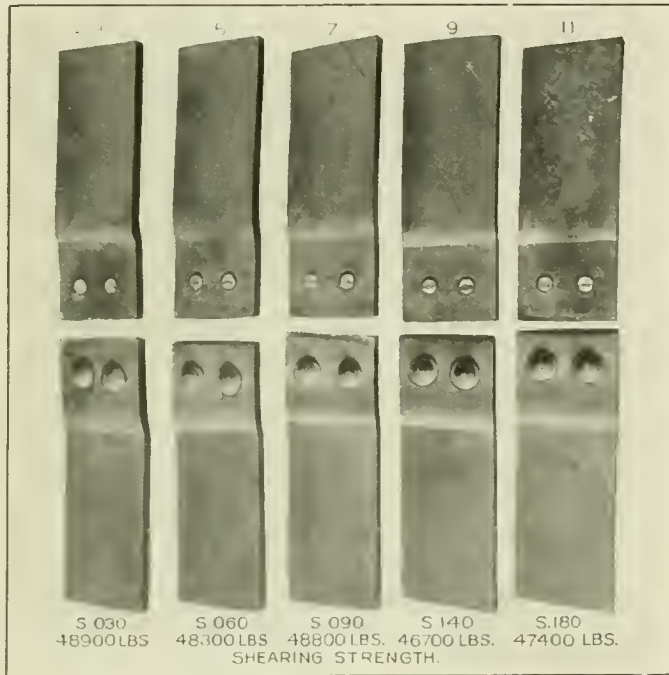

Fig. 3—Shearing Test

very little difference between the low sulphur rivets and those containing six times as much sulphur.

To determine what might be expected of the rivets when in actual service, a number of bars were riveted together.

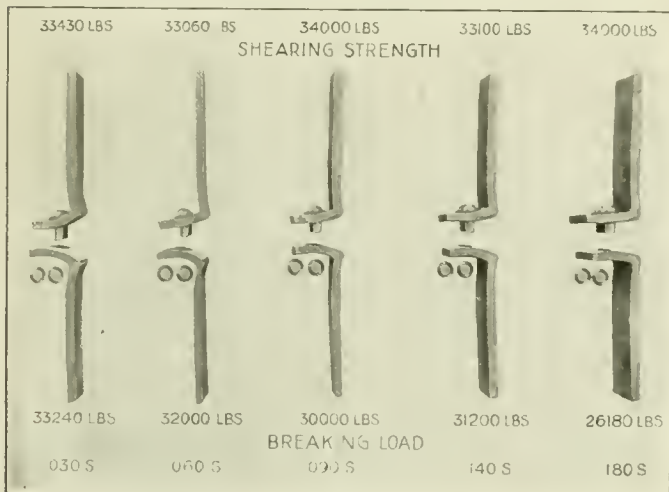

Fig. 4—Tension Test

These samples were then tested to destruction with the results shown in Figs. 3 and 4 and with the breaking loads given in Table I.

TABLE I.—DESTRUCTION TESTS OF RIVETED JOINTS AND ANGLES

Sulphur content	Riveted joints	
	Riveted joints	Riveted angles
.030	48,900	33,240
.060	48,300	32,000
.090	48,800	30,000
.140	46,700	31,200
.180	47,400	26,180

Results of tensile and bending tests on the rolled bars of .09 per cent carbon steel are shown in Table II.

TABLE II.—TENSILE TESTS OF 3/4 IN. DIAMETER ROUNDS AS ROLLED

Sulphur content	Elastic limit,	Ultimate strength,	Elongation in 8 in.,	Reduction of area,
.030	31,360	50,460	30.8	64.2
.060	32,740	50,900	30.2	65.3
.090	30,890	51,400	31.2	62.5
.140	31,600	50,700	32.5	64.2
.180	31,530	50,960	30.7	62.3

In Fig. 5 are shown the results of tests made on extra long rivets under ordinary conditions to determine if one

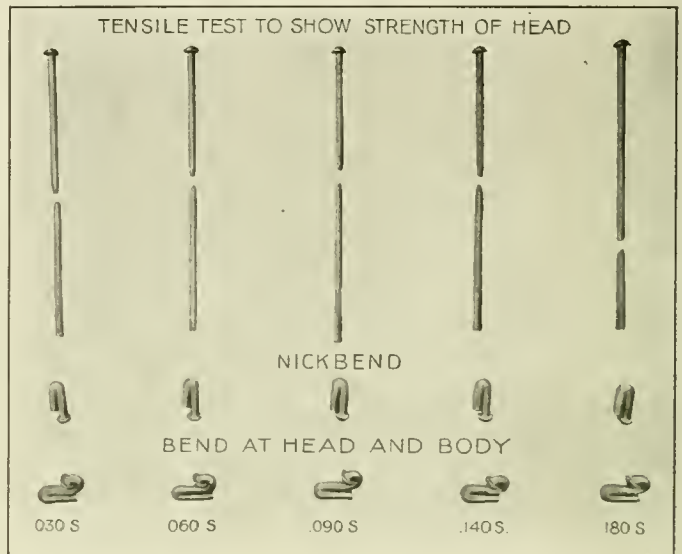

Fig. 5—Tests of Rivets in Ordinary Cold Condition

rivet head would stand as well as another. The nick bends and bending the head of the rivet were made to see if any differences would be found in these cold bends due to the varying sulphur content. Fig. 6 shows a similar set of tests, but in this case the rivets were heated to a driving heat (1,200 deg. C.), then taken out of the fire and quenched in

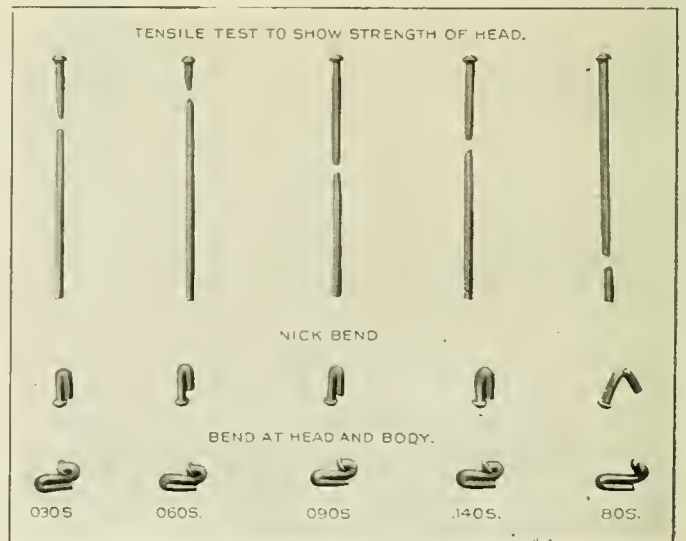

Fig. 6—Tests of Rivets Quenched from Driving Heat

cold water to show the effect of drastic cooling from a high temperature. A third set of tests, similar to those shown in Figs. 5 and 6, were made on rivets which were heated to a blue heat (350 deg.), and then quenched in cold water. The results of these tests were in appearance similar to those shown in Fig. 5.

The object in all these tests was to show whether the different treatments affected the rivets differently and whether

the rivets with higher sulphur content were affected to a greater degree than those with lower sulphur. Tables III, IV and V give the results of the tensile tests.

TABLE III.—TENSILE TESTS OF 3/4 IN. RIVETS IN THE ORDINARY CONDITION

Sulphur content	Elastic limit,	Ultimate strength,	Elongation in 8 in.,	Reduction of area,
.030	34,010	51,740	34.2	70.2
.060	32,820	51,050	34.6	70.4
.090	37,480	51,620	36.0	67.3
.140	34,320	50,320	33.7	67.1
.180	33,340	51,050	37.4	65.8

In addition to these tests, a double shearing test was made on the 3/4-in. rounds of each sulphur content in the ordinary

## ELECTRODE HOLDER FOR ELECTRIC WELDING AND CUTTING

BY C. W. SCHANE

The attached sketch shows a carbon or wire holder for use in cutting or welding locomotive fireboxes and general boiler work, where the electric welder is used. The handle of the holder is placed at an angle of 30 deg. from the center line of the holder, so that the wire will be at right angles to the workman. The wire is held in position by a segmental cam lever, which acts against the underside of a disk head. The cam and disk are grooved and when the wire is fastened in

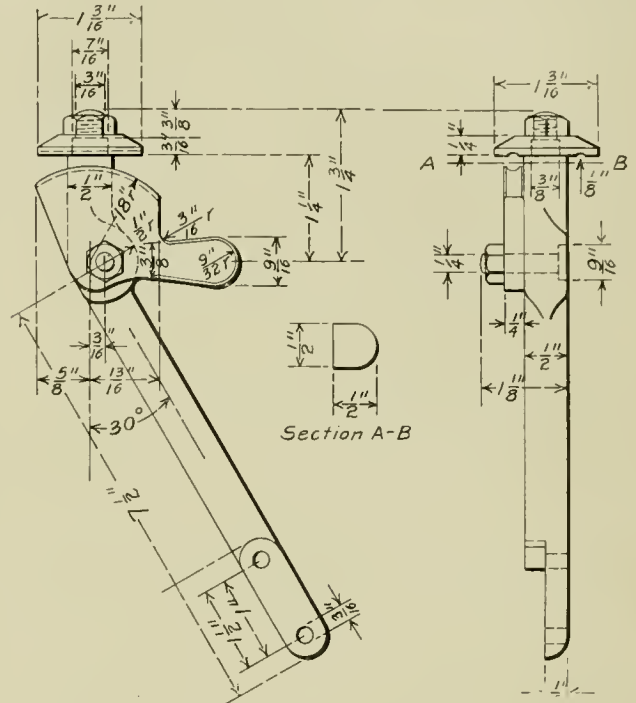

Simple Carbon or Wire Holder for Use in Electric Welding

condition. The shearing strength of each is given in Table VI.

The results of tests and the photographs speak for themselves. These results can be duplicated by anyone who has the necessary facilities. It is believed that the tests indicate the fitness, for most purposes, of a steel rivet containing slightly less than .10 per cent sulphur. So far as the author

this groove it will not loosen as the tendency to press against the metal holds the cam closed.

One of these holders has been in continuous service 24 hours a day for four months and is still giving excellent results. In all electrical appliances a good, firm contact will give the best results, and this holder has fulfilled this requirement. It does not heat or burn as others which we have tried.

TABLE IV.—TENSILE TESTS OF 3/4 IN. RIVETS QUENCHED IN WATER FROM 1,200 DEG. C.

Sulphur content	Elastic limit,	Ultimate strength,	Elongation in 8 in.,	Reduction of area,
.030	44,100	69,700	8.1	62.5
.060	44,450	71,160	9.8	62.7
.090	54,690	76,600	7.6	53.7
.140	49,380	70,520	11.1	58.3
.180	43,730	67,850	10.6	54.8

has been able to determine, there does not appear, by working tests or mechanical tests made on the finished rivet, to be any way of distinguishing between the quality of a rivet of .030 per cent sulphur and one of .090 per cent sulphur, if both have been subjected to the same conditions of treatment.

For many years before basic open hearth steel became com-

TABLE V.—TENSILE TESTS OF 3/4 IN. RIVETS QUENCHED IN WATER FROM 350 DEG. C.

Sulphur content	Elastic limit, lb. per sq. in.	Ultimate strength, lb. per sq. in.	Elongation in 8 in., per cent	Reduction of area, per cent
.030	32,700	50,630	23.0	61.5
.060	31,060	50,400	25.0	59.4
.090	33,430	50,140	32.8	59.2
.140	32,060	49,500	32.0	60.8
.180	32,200	50,510	34.0	60.4

mon, millions of rivets of wrought iron or Bessemer steel were made and used. Bessemer steel is considerably higher in phosphorus, and in most cases higher in sulphur, than basic open hearth, and the greater number of such Bessemer steel rivets are still in service. This is the best possible evidence that steel may contain a much higher sulphur content than is specified today in open hearth steel, without injuring the quality of the rivet.

**A USE FOR OLD PHONOGRAPH RECORDS.**—The wax of old phonograph records may be used with satisfaction on tracing cloth when erasures are necessary. The wax rubbed over the erased portion gives the paper a gloss and finish similar to the original surface and prevents the ink spreading in the lines.—*Machinery*.

## INSPECTION OF LOCOMOTIVE SPARK ARRESTERS AND ASH PANS\*

There are being made on some of the roads comparative tests of the different shapes of mesh, also of the different designs of appliances, but on account of the difference of opinion at this date, we are unable to arrive definitely at what design of front end spark arresting arrangement would be best suited to the locomotives, and at the same time, reduce the emission of live or glowing sparks to the minimum. On some of the roads different appliances are being tried out and it will, of course, take some time to arrive at the merits, but the committee thinks there is no doubt but what there will soon be developed a locomotive front end spark arrester that will greatly reduce, if not altogether overcome, the emission of live sparks from locomotive stacks.

In obtaining from a number of railroads the practice of inspecting the front end arrangements, we find a great

\*From a committee report presented at the third annual meeting of the Railway Fire Protection Association, held in New York, October 3-5, 1916.

variance in the practice. On some railroads the inspection is made after each trip, while on other roads inspections are made once a week, and on others but twice a month. It is the opinion of the committee that the practice of thoroughly inspecting the front end arrangements at the terminals after each trip of the locomotive should be extended to all railroads, and it is also the opinion of the committee that if this practice is carried out, the hazard of sparks emitted from the stacks will be greatly reduced. When speaking of inspection, we believe that men assigned to such duties should be thoroughly familiar with the front end arrangements, and in every instance the inspection should be made in a very thorough manner and a record kept of the condition.

The committee has obtained from several railroads blue prints describing ash pan arrangements. We find that the pans adopted by the different roads are meeting the requirements, from the information we have received the most popular designs being the double sloping pan and the sliding hopper bottom pan. We feel sure that these two designs of ash pan, if properly cared for at the terminal, will be the means of greatly reducing the hazard of fire from this source. We believe that the plan of a thorough inspection should be carried out, the inspections to be made at the terminals at the end of each trip, and a record kept of the condition.

### GAGE GLASS CUTTER

BY E. A. MURRAY

Master Mechanic, Chesapeake & Ohio, Clifton Forge, Va.

Glasses used in steam and air gages at the Clifton Forge shops of the Chesapeake & Ohio are cut by a machine, shown in the illustration, which was designed and built at this shop. It consists of a U-shaped frame similar to the frame of a punch or shear. On the bottom member of this frame is a table plate, which is free to revolve on ball bearings. On the top member is a rubber-lined clamp. Placing a piece of glass

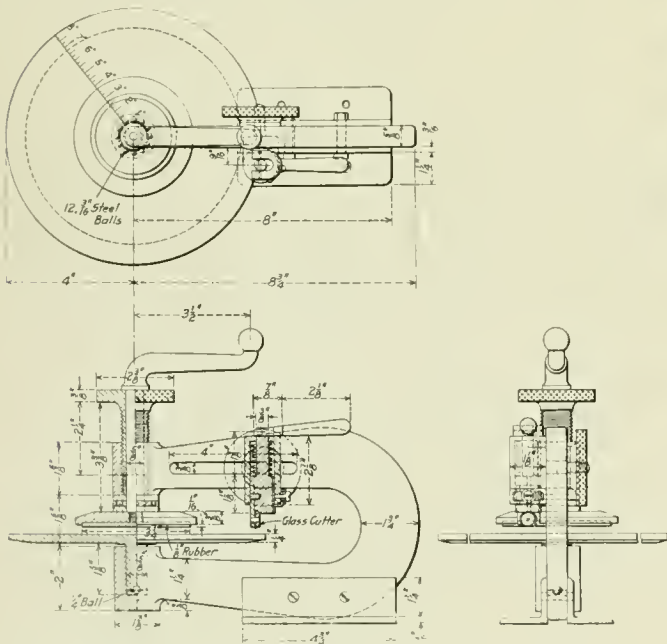

A Simple Device for Cutting Steam or Air Gage Glasses

on the table plate, an adjustment screw forces the rubber-lined clamp down solidly against the glass. The crank arm, which is above the adjustment screw, is revolved and with it the table plate, glass and clamp.

In the top arm of the frame is a slot running lengthwise. The cutter frame works in this slot and has a clamp attached so that the frame can be moved back and forth to secure any diameter glass desired.

### PATCH APPLIED BY ELECTRIC WELDING

BY W. J. GILLESPIE

Boiler Inspector, Pittsburgh & Lake Erie, McKees Rocks, Pa.

The patch shown in the illustration was made necessary on account of a vertical fracture that developed below the center arch tube, extending down to the second line of staybolts as shown by the white line. A section of the sheet embracing the arch tube opening was removed and a patch

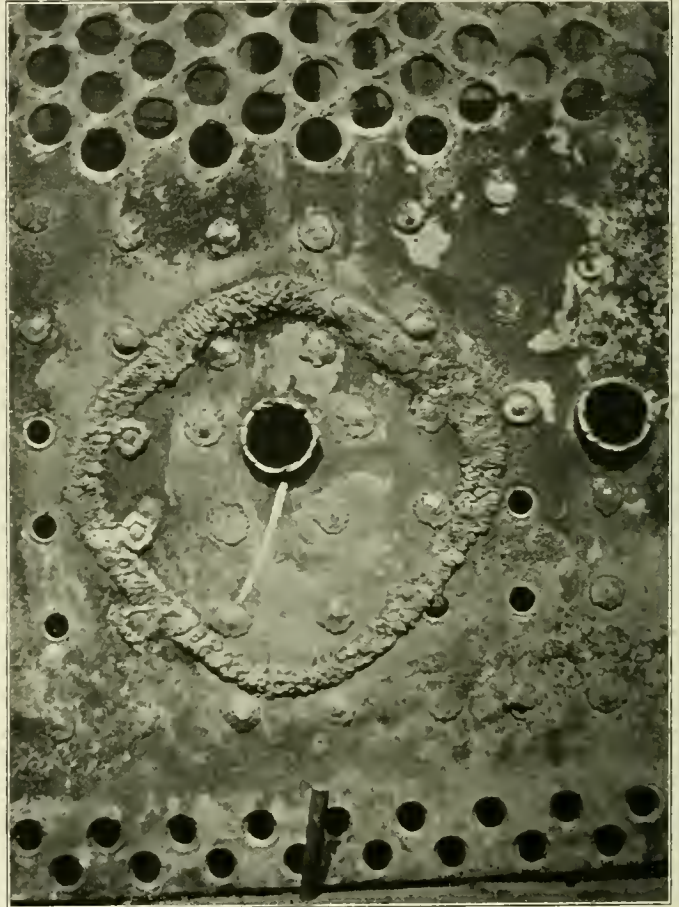

Patch Applied to Back Tube Sheet by Electric Welding

marked off from it. The arch tube and staybolt holes were drilled, the patch set up and the staybolts applied. The seam was then filled in by electric welding and the arch tube applied. This work was done in January, 1915, and the locomotive has since been in continuous service until July, 1916, when it was shopped for renewal of the firebox.

**BOILER TUBES AND SCALE.**—Eminent authorities agree that a layer of scale one-tenth of an inch thick, and a steel boiler plate ten inches thick, offer exactly the same resistance to the passage of heat.—*Railway and Locomotive Engineering.*

**LIGHT MACHINE OIL.**—To make a first-class oil for light machinery, take a bottle about half full of pure olive oil, place in it some thin strips of sheet lead, and expose it to the sun's rays for a month, then pour off the clear oil.—*Pemberthy Engineer and Fireman.*

**BABBITT BEARINGS.**—In motors for very heavy duty the pendulum seems to be swinging back toward babbitt bearings. A good babbitt bearing is more expensive than a good bronze one by 1 per cent of the motor cost. A bearing babbitted with a high-grade tin babbitt calls for an increase of 0.6 per cent over a cheap babbitt, but is a good investment.—*Power.*

# New Devices

## BALANCED DRAFT FOR STATIONARY BOILERS

The conditions on a railroad are such that the stationary boiler plants are required to use coal that is not found desirable for locomotive use. This means that they are often furnished with poor grades of fuel and that unless proper supervision is given, or proper facilities provided by which this fuel may be used to the best advantage, economical results will not be obtained. Those roads that have studied the fuel question thoroughly have not neglected the stationary plants, and several have applied what is known as the "balanced draft" to the boiler plants, with an appreciable saving in fuel cost and an increase in the boiler capacity.

The purpose of the balanced draft is to automatically maintain at a constant, the draft pressure or vacuum in the boiler furnace which will give the proper combustion efficiency. In other words, it so regulates the air supply that the correct amount will be admitted to the boiler furnace

diaphragm box is in communication with the furnace through the passage *B*. As the pressure or vacuum in the furnace varies, the diaphragm moves and operates a water valve which controls the damper regulators *C* and *D* controlling the dampers in the blower pipe and the up-take respectively. The system is so arranged that the blower pipe damper moves to its extreme position before the up-take damper operates. The diaphragm is set to maintain a vacuum above the fuel bed of about .003 in. of water, which is practically equal to the pressure of the atmosphere.

The advantages of this system of draft control are many. As stated above, its purpose is to provide automatically the proper amount of air for complete combustion of the fuel, no more and no less. It maintains a more uniform temperature in the boiler. With the small amount of draft above the fuel bed practically no cold air is drawn in through the leaks in the boiler setting nor through the door as it is opened for firing. For these reasons the boiler is not subjected to sudden changes in temperature, and as a result the life of the

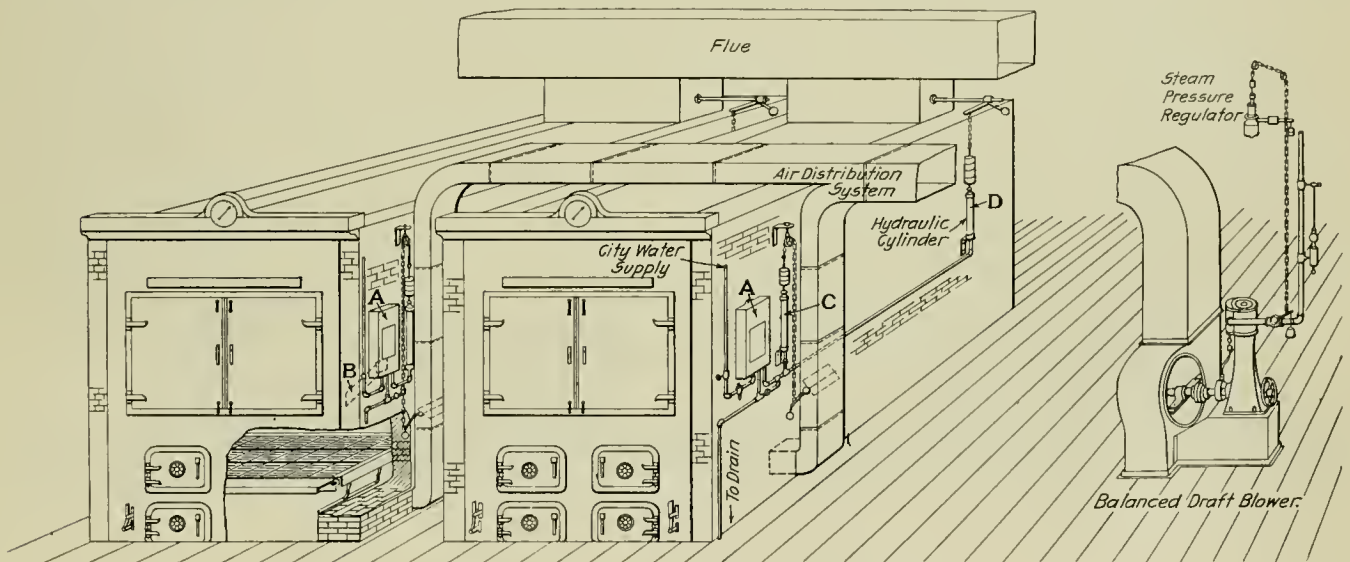

Arrangement of Balanced Draft for Stationary Boilers

to properly consume the coal, no matter what the thickness of the fuel bed may be. With an insufficient air supply some of the gases from the coal will pass out through the chimney unconsumed, and with an oversupply of air the efficiency of the boiler will be decreased, in that the surplus air will absorb and carry away the heat that should be absorbed by the boiler.

The apparatus by which this constant draft is obtained is shown in the accompanying illustration. A forced draft is obtained from the blower on the right, the speed of which is regulated through the speed pressure regulator by the steam pressure in the boiler. This blower provides a constant volume of air to the ash pit at variable pressures for a given speed of the blower. The draft above the fuel bed is maintained constant by the regulator *A*, which consists of a carefully balanced diaphragm supported by knife edges on suitable rests. As shown in the boiler setting at the left, the

boiler is increased and the cost of maintenance decreased. With the light draft required with this equipment the hot gases pass through the boiler at a low velocity, giving the heating surface sufficient time to absorb a maximum amount of heat. With the steam pressure regulator the boiler pressure is maintained more nearly constant, provided sufficient fuel is placed on the grate. This system permits of a cheaper grade of fuel being used, and as the regulation is automatic expert firemen are not required to fire the boiler. It eliminates the varying draft obtained where only chimney draft is used, and limits the function of the chimney to that of conveying the products of combustion away from the boiler.

The balanced draft system, which is controlled by The Engineer Company, 17 Battery Place, New York City, has been adopted quite extensively in industrial plants, and is in use on several railroads in the middle West, including the Chicago, Burlington & Quincy, the Illinois Central, the Atchison,

Topeka & Santa Fé, Chicago & North Western, Chicago Great Western, Chicago & Eastern Illinois, Wabash, Duluth, Missabe & Northern and the Chicago, Indianapolis and Louisville. Tests made by one industrial plant have shown an increase of 13.25 per cent in the equivalent evaporation over and above that which was obtained when natural draft was used, and with a coal that cost 30 per cent less per ton. In tests made by a railroad in the West an increase in equivalent evaporation of 12.52 per cent has been obtained. Other tests have shown similar and even greater increases in boiler efficiency. Since cheaper grades of fuel can be used and the boiler maintenance is less, the ultimate savings are greater than those shown by the increased evaporation.

### AUTOMATIC REFRIGERATOR AND HEATER CAR

The refrigerator car in use on the railways today has been improved from time to time with a view of decreasing the amount of ice consumed and to provide a more perfect circulation of the cold air through the car. While these im-

is controlled by the National Refrigerator Car Company, National Life building, Chicago, follows these principles in that the refrigeration is obtained by the ammonia absorption process and the temperature in the car is automatically regulated by a thermostat. The design and application to the railway car is the invention of William Mack Baxter, formerly of the Illinois Central and the Canadian Pacific. The system is such that a constant temperature anywhere between 32 deg. and 55 deg. F., can be maintained in the car with the outside temperature varying from 55 deg. F., below zero to 105 deg. F. above. Further, as the surrounding temperature drops below that required on the inside of the car the system automatically turns into a heating system by reversing the process of refrigeration.

*Description of the System.*—The system is self-contained and provides its own power. The only work necessary to place the car in operation is to move a lever throwing the system in or out of service, set the thermostat for the temperature desired inside the car and to load the fuel storage magazine once every two weeks. The accompanying illustrations show exterior and interior views of the car, a view of the



Automatic Refrigerator and Heater Car Which Uses the Ammonia Absorption Process

provements have been more or less successful, the perishable freight shippers have never been given the protection that they have been able to secure in the modern cold storage warehouse. In other words, the refrigerator car has remained nothing more or less than an ice box on wheels, regardless of the fact that automatic refrigeration with proper temperature regulation has been in continued successful use in storage warehouses for some time. That the service rendered by these wheeled ice boxes has not been of the best is evidenced by the large amounts paid out in claims for perishable freight by the railways in this country.

The need for a refrigerator car that will maintain a constant temperature in the car automatically and for a period of time sufficiently long to eliminate the necessity of attention from the time the car is loaded until it is unloaded has been appreciated by all traffic men and shippers of perishable products for some time. The principles followed by the cold storage warehousemen is probably the best solution of the problem. The Baxter system of car refrigeration, which

apparatus, a piping diagram of the car, and a temperature chart giving the record of a day's performance of the car. Briefly, the system used is known as the ammonia absorption process of refrigeration and heating and is applicable to all refrigerator cars, either new or those now in service. The theory of this process is that as a liquid vaporizes it absorbs heat from its surroundings, the amount depending on the latent heat of evaporation. This for ammonia is 555 B. t. u. per pound which, excepting water, is the highest of any medium suitable for refrigerating purposes and hence is the liquid most universally used. Further, ammonia is liquefiable at practical pressures. In the Baxter system there are four distinct stages in the process, whether it be performing the function of refrigeration or heating. These are the generation of ammonia gas, condensation of the gas, expansion of the condensed gas from a liquid back to a gas, and the absorption of the gas in water for regeneration.

*Refrigeration.*—The apparatus having been charged with a strong aqua ammonia solution (26 deg. Baume) and the



charcoal magazine filled, a fire is started on the grate *A* to which the charcoal is fed automatically from the magazine which has a capacity of 14 days continuous operation. The ammonia having a lower boiling point than water, is dis-

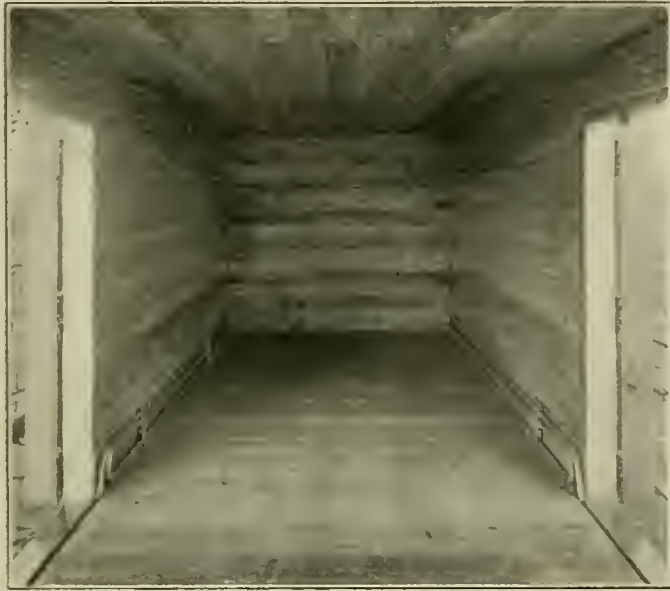

Interior View Showing Refrigerating Coils Located on Upper Side Walls and Near the Floor

tilled off first leaving behind the water which is now weak in ammonia. The generator *B* is so constructed that practically all of the strong ammonia solution is forced into it by the pump *C*, which by the way is operated by the ammonia

The ammonia gas passes up through the pipe *F* to what is called the analyser, which is a long vertical pipe exposing sufficient surface to condense and precipitate any entrained moisture back to the generator. The gas is then passed through a coil to remove any superheat it may contain before it passes to the condenser *G*. In the condenser the ammonia gas is liquefied ready to be revaporized at the expansion valve *H*. This revaporization produces the refrigeration and the gas as it passes through the refrigerating coils *I* located on the upper side walls of the car, abstracts the heat from the car and its load and passes on to the absorber *J* to be again taken up by the weak water solution. This solution comes from the kettle *E*, passing through the stand-pipe *K* to the temperature exchanger *L* which is nothing more than a pipe within a pipe. The hot weak liquor passing over the cool, strong solution on its way from the pump to the generator, preheats the latter and cools the former. From *L* the weak liquor passes through spray nozzle *M* into the pump exhaust absorber *N* and absorbs the exhaust ammonia gas from the pump. The solution thus becomes stronger. From there it passes through the radiator *O* where it is cooled and is sprayed into the absorber *J*, as shown in the piping diagram, reuniting with the ammonia gas from the refrigerator coils. From *J* the liquid passes to the pump and is forced into the generator, being preheated at *P* by the heat of the exhaust ammonia gas from the pump, and at *L* as described above. The ammonia gas for driving the pump is taken from the analyser and passes through the pump regulator *Q*. This regulator is of the float type and maintains the liquid in the generator at a predetermined height. The exhaust from the pump passes into the absorber as described above. Thus it will be seen that all the ammonia gas is recollected without loss and the pump is the only moving part of the apparatus. This explains the continuous cycle of operation when the

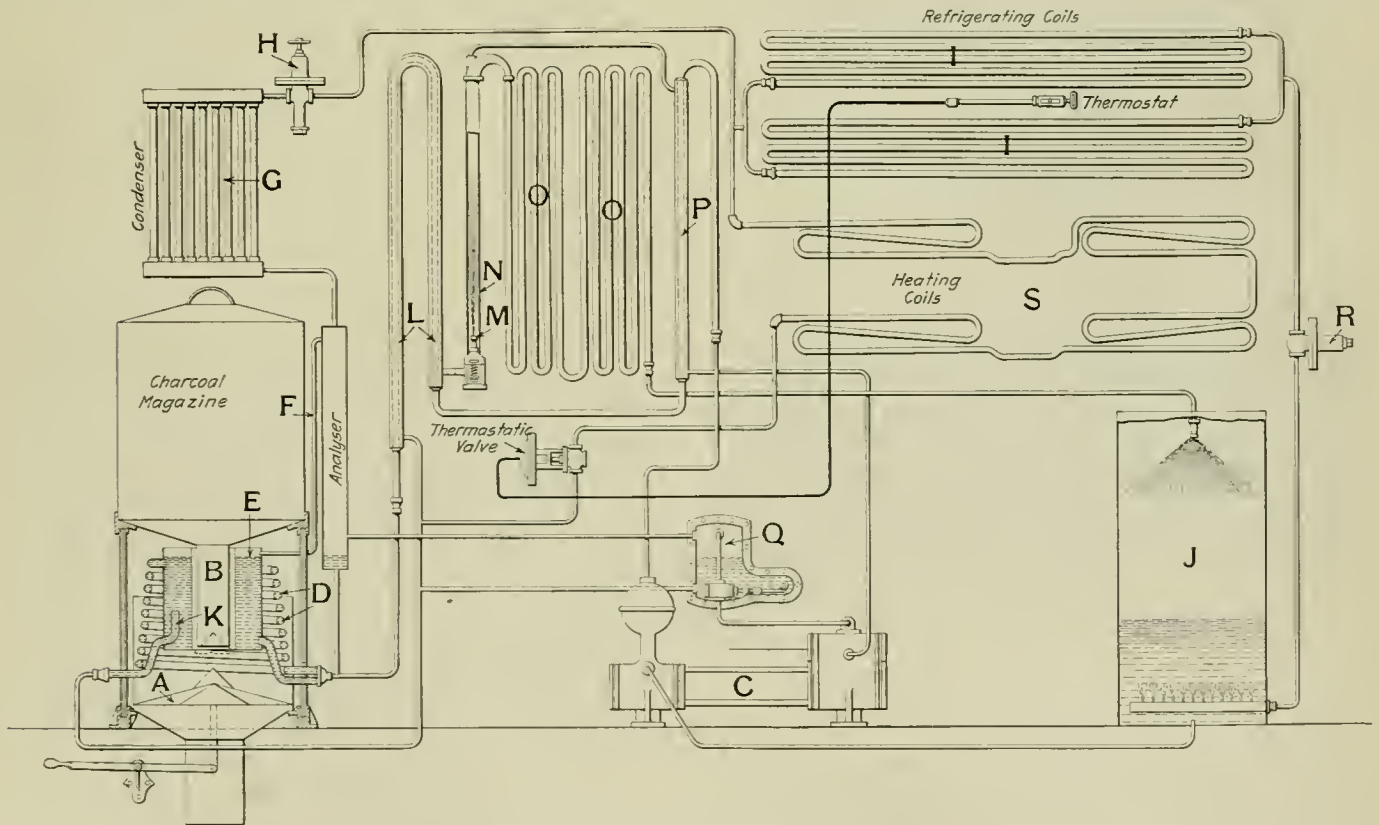

Diagram of Automatic Refrigerating System

gas under pressure, and passes through the generator coil *D*. Here most of the ammonia gas is boiled off collecting at the top of kettle *E* leaving the solution in the kettle weak in ammonia. This fact permits rough switching without causing the liquid to foam.

machine is refrigerating. The check valve *R* is interposed in the line leading from the refrigerating coils to the absorber *J* for the purpose of preventing a back surge of the ammonia into the refrigerating coils and killing the frost.

*Heating.*—When the temperature in the car has been low-

ered below the point for which the thermostat is adjusted, the fluid in the sensitive element of this device contracts and opens the thermostatic valve. This allows hot weak liquor from the generator through the stand pipe *K*, to flow through the heating coils *S* and thus give up its sensible heat. However, this fluid after passing through these coils becomes cool upon completing its course. This fluid is now conducted to the refrigerating coils and, as the automatic expansion valve always remains open in service position, it readily absorbs the ammonia gas coming therefrom in the refrigerating coils which now virtually perform the function of an absorber and throw off the chemical heat of combination known as the heat of absorption. Therefore, heat from two sources is liberated simultaneously within the car to warm it. When the temperature in the car has risen and expanded the fluid in the thermostat sufficiently to close the thermostatic valve, the heating coils *S* become neutral in temperature and the gas continuing to expand through the expansion valve empties the refrigerating coils of the aqua ammonia fluid into the secondary absorber *J*. When they are blown free the expanded gas causes them to again become frosted and the car now operates as a refrigerator.

*Location of Parts.*—The generator, pump, pump regulator, absorber *J*, and the charcoal magazine are located in one end of the car, as shown in one of the illustrations, occupying a space 4 ft. long from the face of the end sill to the face



End View with End Door and Ventilators Removed to Show Mechanism

of the sheathing of the insulated wall. The refrigerating and heating coils are located at the top and bottom of the sides of the car, respectively, as shown in another illustration. The thermostat is located at the ceiling near the center of the car, and the expansion valve is also inside the car at the end. The condenser *G* is placed underneath the car, together with the temperature exchangers *L* and *P*, the pump exhaust absorber *N* and the absorber radiators *O*. There is another coil of pipe not shown in the piping diagram between the analyzer and the condenser *G*, which is used to remove the superheat from the ammonia gas before it reaches the condenser.

*Advantages of the System.*—Among the advantages that may be mentioned for this system of transporting perishable freight may be mentioned the automatic feature of obtaining refrigeration or heating as the outside temperature demands; the inside volume of the car will be increased from 6 to 8 per cent over the ice refrigerated cars; the increase in time between chargings; more uniform temperature with less liability for damage to the lading; elimination of the large cost for ice and ice houses, less weight per car than where ice is used, elimination of deterioration of the equipment and tracks caused by brine drippings and a lower car center of gravity. This system will also give a dry atmosphere within the car. This enables certain commodities to be handled

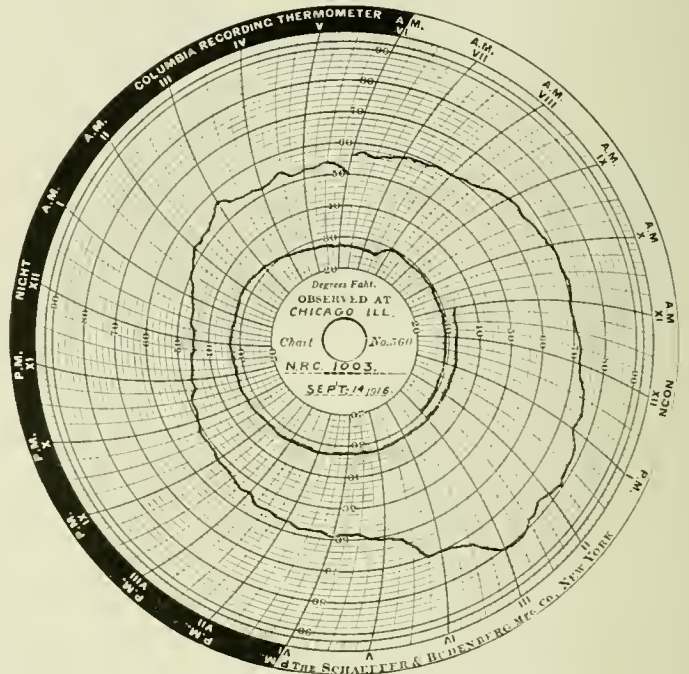

Temperature Chart Showing Range of Inside and Outside Temperatures

with greater safety, as low humidity greatly assists in delaying the process of decomposition. There is also a large reduction in operating costs over other systems, inasmuch as the charcoal consumed costs but 75 cents per day, as compared with the average daily icing cost of \$3.75.

The accompanying temperature chart shows how well the inside temperature of the car was maintained with a variation of over 30 deg. in the outside temperature. This test was made on an empty car and is considered a severe test, as the load in a refrigerator car acts as a heat reservoir to smooth out the temperature curve within when any very great variations in outside temperatures are encountered.

This process will change from a heater to a refrigerator or vice versa as the requirements of the weather and commodities demand, in from two to three hours, and the machine will perform either function in approximately three and one-half hours from the time the fire is lit. This is of material benefit in that it will be unnecessary to hold the equipment ahead of the load for the proper temperature as is now required, with the cars in service today. The car can be used for handling meat, fruits or vegetables without any alteration other than the adjustment of the thermostat and in this respect meets the demands of universal service.

The machine has a capacity of one ton of ice per day, or the equivalent of removing 284,000 B. t. u. in 24 hours, which affords a safe excess over the present ice meltage of standard refrigerator cars. All piping in the car is continuously welded and without joints. Those joints shown in the illustration have been eliminated. The weight of the

machine complete with ammonia charge is 5,825 lb. and the concentrated weight at the end of the car of all mechanism including an ammonia charge of 600 lb. and a charcoal charge of 1,400 lb., is 3,900 lb.

### TRUCK SAFETY ATTACHMENT

An attachment the function of which is to set the air brakes automatically whenever the car or tender truck to which it is attached is derailed or becomes broken, has been placed in successful operation on several railroads by the Wright Safety Air Brake Company, Greensboro, N. C. It consists of a valve, attached to the body of the car or tender, connected to the brake pipe underneath. A

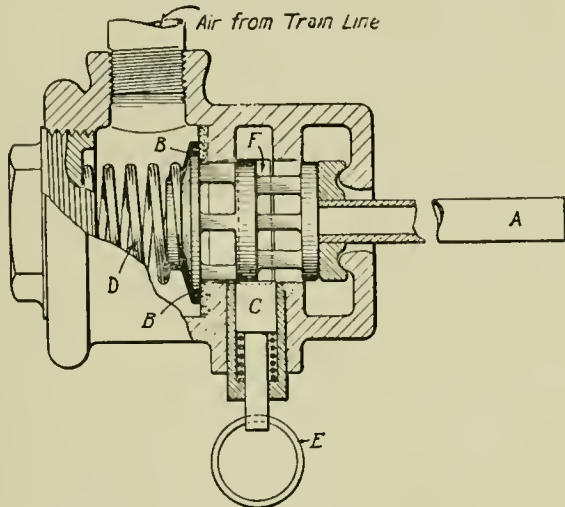

Section of Valve for Truck Safety Attachment

section of this valve is shown in one of the accompanying illustrations. It is operated by the pin *A* which is in direct line with the center bearings of the car and extends through an adjustable collar located on the track. As the pin *A* is moved in any direction by this collar it rocks the disc to which the pin is attached, forcing the valve *B* from its seat and allowing air from the brake pipe to pass

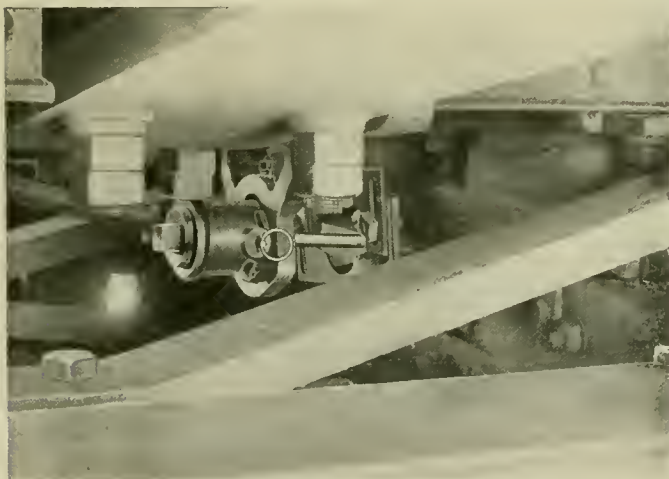

Truck Safety Attachment Applied to a Freight Car

out through the opening *F*, thus setting the brakes. If this pin is deflected to any great extent, as it would be in case the truck was derailed, it will force the valve back far enough to allow the plug *C* to spring in behind the valve holding it in the open position. The valve is held in the closed position by the spring *D* and when once opened to

its extreme position is reclosed by pulling out the plug *C* by means of the ring *E*.

The collar surrounding the pin *A* is adjusted to suit the conditions in which the car operates so that the device will not be operated by the normal movement of the truck. This movement may be taken by test, a pencil replacing the pin and a chart the collar. The record of the movement of a baggage car truck is shown in one of the illustrations. This device has been installed on several railroads where it has prevented serious wrecks by stopping the train when



Record of the Movement of a Baggage Car Truck with Reference to the Car Body (slightly over full size)

the truck to which it was applied became defective. It will operate whenever the trucks leave the rails whether due to a broken rail, spread rails or for any other reason. It will also be operated by a broken journal, arch bar or spring, by splitting a switch, or by any other abnormal condition affecting the movement of the truck and threatening the safe progress of the train.

### UNIVERSAL TUBE WELDER

Flue welders, which roll the tubes from the outside, have a tendency to reduce the inside diameter at the weld, and the reduced diameter at the weld has a tendency to increase the resistance to the free passage of the hot gases through the tubes. With this in mind, the Southwark Foundry &

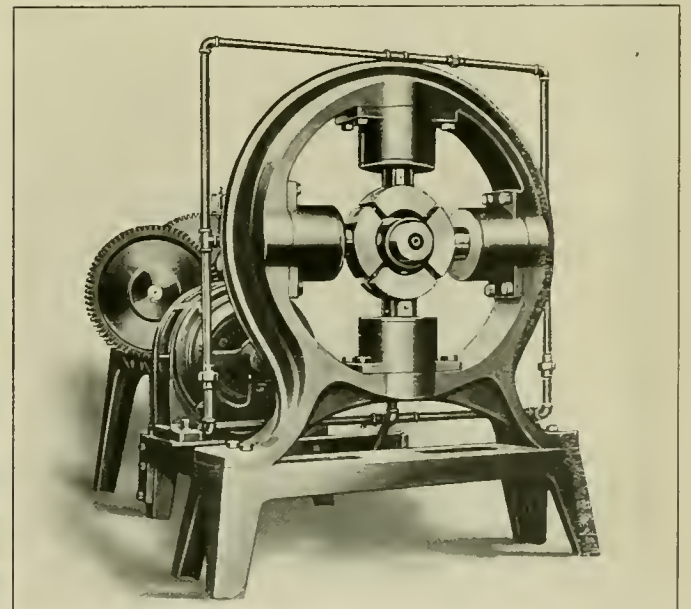

Universal Flue Welder With Furnace Removed

Machine Company, Philadelphia, Pa., has designed a universal flue welder which rolls the flues from the inside.

The illustration of the front of the welder shows four air cylinders, all piped together and working simultaneously. The pistons in these cylinders operate the clamping heads which hold the flue against the welding mandrel. The mandrel, which is hollow, fits inside the tube and on it are assembled four tapered rollers. These rollers are free in their bearings and can be moved radially by inserting a

taper mandrel that reaches through the center of the spindle from the back of the machine. This mandrel is operated by means of an air cylinder controlled by the main foot valve.

A furnace is located directly in front of the welding mandrel. This is done in order that there may be as little heat lost as possible in transferring the tube to the welding machine and also to cut down to a minimum the time necessary for the transfer. A cast iron tank, or water back, protects the welding head from excessive heat from the furnace.

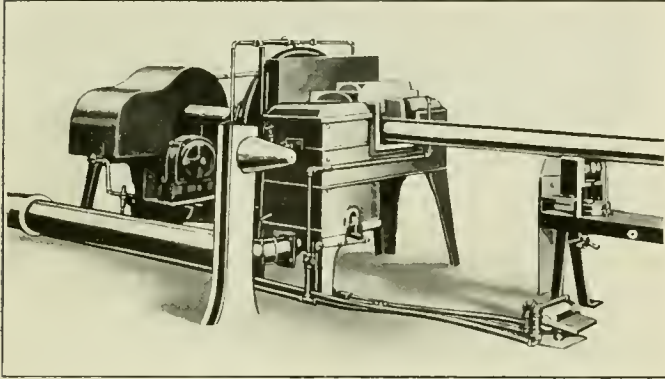

Universal Flue Welder and Furnace Complete

The size of the mandrel back of the welding rollers approximates the inside diameter of the flue and supports the weight of the safe end while being heated and moved to the welding position.

The operator uses a foot valve which controls the entire operation of the welder. The piping is so arranged that the clamping heads close in on the outside diameter of the flue before the taper mandrel expands the rollers to make the weld. Driven directly from the motor, the mandrel is started by an air chuck operating automatically with the

## HEAVY DUTY ENGINE LATHE

A heavy duty lathe recently placed on the market by the Houston, Stanwood & Gamble Company, Cincinnati, Ohio, is shown in the illustration. This lathe was developed to meet a heavy demand for a high-grade tool of large swing and great power. It has a swing of 30½ in. over the V's and 18¼ in. over the bridge. The carriage is 44 in. long and the bridge width 16 in. The lathe has a 30-in. face plate, all gears are of steel and the important bearings are thoroughly bushed, bronze bushings being used on the front and rear spindle bearings. Both head and tailstock are carried on the rear V's. The tailstock is of the set over pattern and in addition to four accessible bolts, is held by a pawl engaging a rack cast in the bed, midway between the V's. The tailstock spindle is 4¼ in. in diameter and has a travel of 12 in.

This lathe is of the double back-gear type and, when belt driven, is fitted with a three-step cone designed to fit a belt six in. wide. The ratio produced by the two back-gear reductions is 3.55 and 12.5, respectively, and with counter shaft speeds of 243 and 128 revolutions per minute, a total of 18 spindle speeds is available, varying from 8.3 r. p. m. to 300 r. p. m. With a counter shaft speed of 243 revolutions per minute and the belt on the middle step of the cone, 16 hp. is transmitted to the lathe.

The carriage is guided by the front V, which is of the broad, low-angle type. A range of from 1 to 14 threads per inch may be obtained without additional feed gears. Between 1 and 1½ threads per inch, the steps are by eighths of a thread per inch. From 1½ to 3 threads per inch, the steps are by quarters, from 3 to 6 by halves, while from 6 to 14, the steps are one thread per inch. Twenty-four feeds are provided without gear changes. By the use of additional gear changes any United States standard thread or metric thread, and any feed, may be obtained. When specified, a housing is furnished covering the entire top of the headstock, to receive a motor for motor drive. Any length of

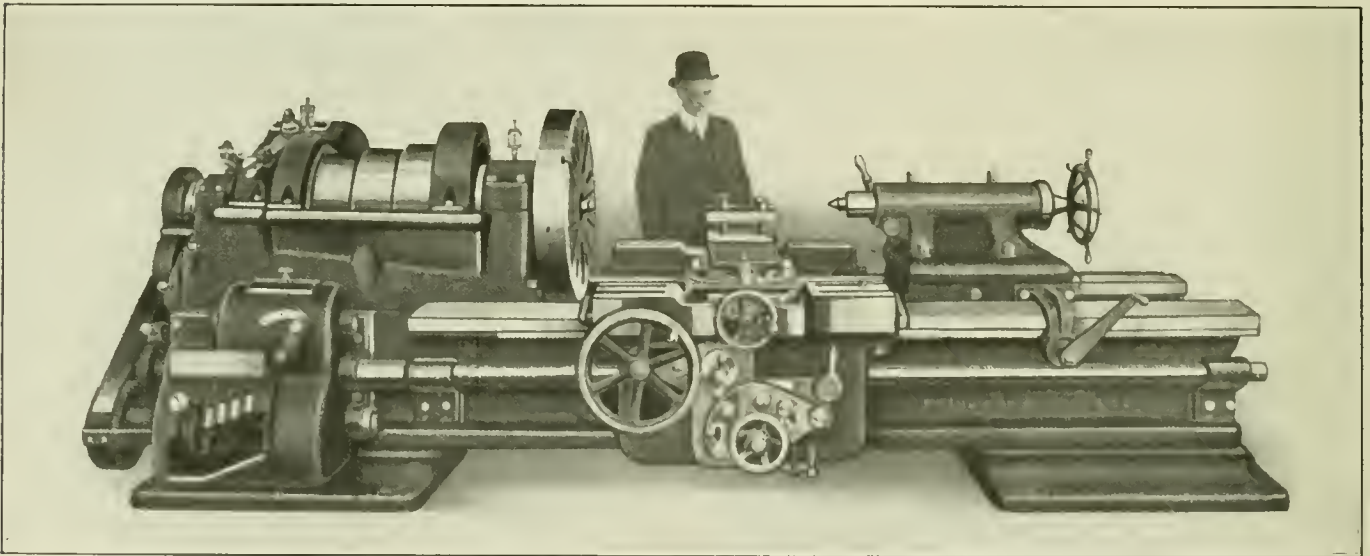

Heavy Duty Double Back Gear Engine Lathe

clamping of the flue. The main mandrel is driven through two gear reductions by a 1½-hp. motor. This motor is mounted on the framework underneath the gearing and takes up very little space. Cut gears are used throughout.

It is estimated by the builders that one crew can easily weld in a day of 10 hours, 120 superheater flues, the machine having a capacity up to 5½-in. flues. The air pressure required is 80 to 100 lb. and the floor space occupied 3 ft. 6 in. by 9 ft.

bed desired can be furnished up to 30 ft. When mounted on skids and equipped with motor drive (excluding the weight of the motor) the lathe with the minimum length bed weighs approximately 18,000 lb.

**PIG IRON PRODUCTION.**—The total pig iron production in the United States for the first half of 1916 was 19,610,522 tons. The production of pig iron in Canada during the same period was 507,750 tons.

# Railway Mechanical Engineer

(Formerly the RAILWAY AGE GAZETTE, MECHANICAL EDITION  
with which the AMERICAN ENGINEER was incorporated)

PUBLISHED ON THE FIRST THURSDAY OF EVERY MONTH BY THE  
SIMMONS-BOARDMAN PUBLISHING COMPANY

EDWARD A. SIMMONS, *President* L. B. SHERMAN, *Vice-President*  
HENRY LEE, *Vice-President and Treasurer* M. H. WIUM, *Secretary*  
WOOLWORTH BUILDING, NEW YORK, N. Y.  
F. H. THOMPSON, *Business Manager*, CHICAGO.

Chicago: Transportation Bldg. Cleveland: Citizens' Bldg.  
Washington: Home Life Bldg.  
London: Queen Anne's Chambers, Westminster.

ROY V. WRIGHT, *Editor*  
R. E. THAYER, *Managing Editor*

C. B. PECK, *Associate Editor* E. S. BARNUM, *Associate Editor*

Entered at the Post Office at New York, N. Y., as mail matter of the  
second class.

Subscriptions, including the eight daily editions of the *Railway Age Gazette* published in June in connection with the annual conventions of the Master Car Builders' and American Railway Master Mechanics' Associations, payable in advance and postage free: United States, Canada and Mexico, \$2.00 a year; Foreign Countries (excepting daily editions), \$3.00 a year; Single Copy, 20 cents.

WE GUARANTEE, that of this issue 8,850 copies were printed; that of these 8,850 copies 7,623 were mailed to regular paid subscribers, 118 were provided for counter and news companies' sales, 555 were mailed to advertisers, exchanges and correspondents, and 554 were provided for new subscriptions, samples, copies lost in the mail and office use; that the total copies printed this year to date were 100,450, an average of 8,371 copies a month.

The RAILWAY MECHANICAL ENGINEER is a member of the Audit Bureau of Circulations.

VOLUME 90

DECEMBER, 1916

NUMBER 12

## CONTENTS

### EDITORIALS:

The Prize Competitions.....	611
The Making of an Executive.....	611
Machining Locomotive Journals.....	611
Locomotive Headlight Hearings.....	611
Promotions in the Mechanical Department.....	612
The Situation at Washington.....	612
Do Your Equipment Buying Early.....	613
New Books.....	613

### COMMUNICATIONS:

Tobesura Weno on the Headlight Law.....	614
Broaden Your Vision.....	614

### GENERAL:

Traveling Engineers' Convention.....	615
Preparedness and the Railways.....	620
Modern British Goods Locomotives.....	621
The Kiesel Train Resistance Formulas.....	627
Air Reservoir Support.....	628
The I. C. C. Headlight Hearings.....	629
Adjustable Air Pump Bracket.....	631
Safety Valves.....	631
Report of the I. C. C. Division of Boiler Inspection.....	632

### CAR DEPARTMENT:

A Hopper Car of 200,000 lb. Capacity.....	633
Portable Cut-Off Saw.....	636
Car Inspectors' and Car Foremen's Meeting.....	637
Canadian Government Sleepers.....	644
Gage for Steel Wheels.....	648

### SHOP PRACTICE:

Oxy-Acetylene Welding in Boiler Repairs.....	649
A Locomotive Axle Failure.....	650
Rack for Storing Smoke Box Front Ends.....	651
Why Have an Apprentice School?.....	651
Drift for Truing Up Supply Valve Stem Guides.....	652
Union Pacific Method of Facing Driving Box Wedge Shoe and Wedge Faces.....	652
Operation of a General Flue Shop.....	653
Boiler Steel Cylinder Patch.....	655
Pneumatic Clamping and Holding-On Devices.....	655
Pneumatic Riveting Machine.....	656
Turning a Boiler Maker Apprentice into a Good Mechanic.....	656
The Effect of Sulphur in Rivet Steel.....	657
Electrode Holder for Electric Welding and Cutting.....	659
Inspection of Locomotive Spark Arresters and Ash Pans.....	659
Gage Glass Cutter.....	660
Patch Applied by Electric Welding.....	660

### NEW DEVICES:

Balanced Draft for Stationary Boilers.....	661
Automatic Refrigerator and Heater Car.....	662
Truck Safety Attachment.....	665
Universal Tube Welder.....	665
Heavy Duty Engine Lathe.....	666

### NEWS DEPARTMENT:

Notes.....	667
Meetings and Conventions.....	668
Personals.....	670
Supply Trade Notes.....	672
Catalogues.....	674

The executive committee of the Master Car Builders' Association has issued Circular No. 14, stating that on account of labor and material delays the date at which the tank car specifications for Class III and IV tank cars were to become effective, has been extended 60 days, to March 1, 1917.

At the Reading (Pa.) shops of the Philadelphia & Reading last Saturday afternoon the general manager, Charles H. Ewing, presented to the Reading shop baseball team the A. T. Dice cup. This team won the pennant in competition with several other Reading system teams during the past season. There was music by the shop band, and singing by some of the shopmen.

Asa Farrar, claim adjuster of the Seaboard Air Line, has secured a patent on a locking arrangement for switch stands to be used for the benefit of car repairers. Repairers, to insure their own safety when working under cars on the repair tracks, lock the switch leading to that track with a padlock.

The repair man has in his possession the only key to the lock; and Mr. Farrar's device is to provide for the employment of this safeguard by any number of repair men at the same time. The switch having been locked by each of the men with his individual lock, it cannot be again moved until all of the locks which have been put on it have been released.

The Railway Engineering Experimental Station of the University of Illinois has made arrangements with the International Railway Fuel Association and the United States Bureau of Mines to conduct a series of coal tests in the locomotive testing plant, the Baltimore & Ohio having loaned a Mikado type freight locomotive for that purpose. This locomotive weighs with its tender, a total of 464,000 lb. and has a tractive effort of 54,000 lb. Samples of coal to be used will be taken from Illinois mines and will be graded according to the present commercial sizes, ranging from the so-called slack and run-of-mine, up to the commonly used

2-in. by 6-in. lumps. The tests will be made both with hand and stoker firing, and later it is the intention to conduct a series of tests with pulverized coal.

The Southern Pacific has awarded 78 gold watch fobs, suitably engraved and bearing the company's safety emblem, to employees who did the most towards furthering "safety first" work during the past fiscal year. C. H. Rippon, piece-work inspector at the general shops at Sacramento, Cal., headed the list with a score of 1,293 points. Ten and one-half points are granted for each safety suggestion made involving a change in standard practice to correct a defect the practical working out of which requires actual labor, and indicates the thoughtful attention of the employee. For each suggestion which warrants the issuance of instructions to employees, but does not involve physical labor in its application, five points are given. One credit is granted for each suggestion not involving actual labor in its application, and which heretofore has been covered by instructions.

A CORRECTION

In the report of the Chief Interchange Car Inspectors' & Car Foremen's Association published in the November issue of the *Railway Mechanical Engineer*, page 571, some remarks under the heading of Discussion of Interchange Rules were attributed to F. H. Hansen of the New York Central, and S. Hanson of the Peoria & Pekin Union, which were made by William Hansen, chief joint inspector, at Denver, Colo. William Hansen spoke on Rule 3, Section C, Rule 9 and Rule 98.

CARS AND LOCOMOTIVES ORDERED IN NOVEMBER

As noted elsewhere in this issue the orders for cars and locomotives reported in November exceeded those for any other month in the last three years, there having been orders reported as follows:

	Locomotives	Freight Cars	Passenger Cars
Domestic .....	408	44,001	510
Foreign .....	755	.....	.....
Total .....	1,163	44,001	510

So many large orders were reported during the month that space will permit only the notation of some of the more important ones. Among the locomotive orders were included the following:

Road	No.	Type	Builder
Atlantic Coast Line.....	5	Switching .....	Baldwin
	20	Pacific .....	Baldwin
Chicago & North Western.....	25	Mikado .....	American
	12	Pacific .....	American
	40	Switching .....	American
El Paso & Southwestern.....	10	Pacific .....	American
Erie .....	15	Santa Fe .....	American
Florida East Coast.....	10	Pacific .....	American
	2	Switching .....	American
Missouri, Kansas & Texas.....	10	Pacific .....	American
New York, Chicago & St. Louis.....	25	Mikado .....	American
	20	Switching .....	Lima
Norfolk & Western.....	8	Mountain .....	Company shops
	1	Mallet .....	Company shops
Southern .....	12	Mallet .....	Baldwin
	8	Mountain .....	Baldwin
	25	Santa Fe .....	Baldwin
	16	Santa Fe .....	Baldwin
	20	Mikado .....	Baldwin
Wabash .....	25	Santa Fe .....	American
British Government .....	450	4-6-0 .....	Baldwin
French Government .....	100	.....	Baldwin
Italian State Railways.....	40	Consolidation .....	American
Norwegian Railways (various).....	22	.....	Baldwin
Paris-Lyons Mediterranean (France).....	40	Mikado .....	Baldwin
Russian Government .....	40	Decapod .....	American
	20	Decapod .....	Canadian

Among the important orders for freight cars were the following:

Road	No.	Type	Builder
Atlantic Coast Line.....	1,200	Box .....	Barney & Smith
	500	Flat .....	Barney & Smith
Atchison, Topeka & Santa Fe.....	500	Tank .....	Pressed Steel
	1,000	Stock .....	Haskell & Barker
Baltimore & Ohio.....	2,000	Box .....	Mt. Vernon
Cambria & Indiana.....	2,000	Hopper .....	Cambria
Chicago, Burlington & Quincy.....	500	Gondola .....	Western Steel
	1,000	Automobile .....	Haskell & Barker
	2,000	Box .....	Haskell & Barker

Delaware, Lackawanna & Western.....	500	Box .....	Am. C. & F.
	500	Hopper .....	Am. C. & F.
Erie .....	1,000	Box .....	Haskell & Barker
	1,000	Box .....	Am. C. & F.
Great Northern .....	1,000	Box .....	Pressed Steel
	500	Automobile .....	Haskell & Barker
	500	Refrigerator .....	Haskell & Barker
	500	Refrigerator .....	Refrig., Heat, & Vent. Car
Illinois Central .....	400	Ballast .....	Rodger
	1,000	Gondola .....	Pullman
	1,000	Gondola .....	Haskell & Barker
Louisville & Nashville.....	750	Box .....	Company shops
	750	Gondola .....	Company shops
	1,000	Gondola .....	Mt. Vernon
	1,000	Gondola .....	Company shops
Minneapolis, St. Paul & S. S. Marie	800	Box .....	Haskell & Barker
	200	Automobile .....	Haskell & Barker
Missouri, Kansas & Texas.....	1,000	Stock .....	Am. C. & F.
Philadelphia & Reading.....	1,000	Hopper .....	Cambria
	500	Hopper .....	Pressed Steel
	500	Hopper .....	Standard Steel
Southern .....	1,313	Gondola .....	Pressed Steel
	1,350	Box .....	Lenoir
	200	Stock .....	Lenoir
	100	Caboose .....	Lenoir
Union Railroad .....	1,250	.....	Pressed Steel
	750	Gondola .....	Ralston
Union Pacific .....	1,500	Box .....	Am. C. & F.
	1,000	Automobile .....	Ralston
Wabash Pittsburgh Terminal.....	1,000	Hopper .....	Pressed Steel

The New York Central's order for 300 passenger train cars is the largest order for steam railway passenger equipment for a very long time. There were also other important orders in November.

Road	No.	Type	Builder
Baltimore & Ohio.....	75	Coaches .....	Pullman
	25	Combination .....	Pullman
New York Central.....	50	Coaches .....	Pressed Steel
	25	Coaches .....	Barney & Smith
	25	Baggage .....	Pullman
	125	Baggage .....	Am. C. & F.
Norfolk & Western.....	75	Coaches .....	Standard Steel
	22	Coaches .....	Har. & Holl.
	28	Combination .....	Har. & Holl.
Western Maryland .....	17	Coaches .....	Pullman
	6	Combination .....	Pullman
	2	Cafe .....	Pullman

MEETINGS AND CONVENTIONS

*Air Brake Association.*—The 24th annual convention of the Air Brake Association will be held at Memphis, Tenn., May 1-4, 1917.

*The June Mechanical Conventions.*—Atlantic City has been chosen by the executive committees of the Master Car Builders and the Master Mechanics' associations as the place for holding the 1917 conventions. The Master Mechanics' Association convention will be held first this year, starting on Wednesday, June 13. The Master Car Builders will follow, commencing Monday, June 18. The vote as to whether the convention should go to Chicago or Atlantic City was especially close this year, and the question was only decided after an extended discussion by the two executive committees sitting in executive session. The Chicago Chamber of Commerce presented an able argument, offering the associations the exclusive use of the Municipal Pier for both the exhibits and the convention.

President Edmund H. Walker, of the Railway Supply Manufacturers' Association, has appointed the following committees:

Exhibit committee, J. G. Platt (chairman), Hunt-Spiller Manufacturing Corporation; George R. Carr, Dearborn Chemical Company, and C. W. Beaver, Yale & Towne Manufacturing Company.

Finance committee, J. F. Schurch (chairman), Damascus Brake Beam Company; George H. Porter, Western Electric Company, and William McConway, Jr., McConway & Torley Company.

Hotel committee, George H. Porter (chairman), Western Electric Company; C. P. Cass, Westinghouse Air Brake Company, and H. G. Thompson, Edison Storage Battery Company.

Badge committee, C. D. Eaton (chairman), American Car & Foundry Company; C. W. Beaver, Yale & Towne Manufacturing Company, and George A. Cooper, Frost Railway Supply Company.

By-laws and resolutions committee, P. J. Mitchell (chair-

man), Philip J. Justice & Co.; Frank Beal, Magnus Metal Company, and C. P. Cass, Westinghouse Air Brake Company. Entertainment committee, E. H. Bankard, Jr. (chairman), Midvale Steel Company. Enrollment committee, Charles H. Gayetty (chairman), Quaker City Rubber Company. Transportation committee, L. S. Wright (chairman), National Malleable Castings Company.

**Committees for the Master Mechanics' Association.**—The committees for the Master Mechanics' Association, which are to report at the 1917 convention, have been appointed. The following four special committees, which reported last year, have been discontinued: Equalization of Long Locomotives, Dimensions of Flange and Screw Couplings for Injectors, Best Design and Material for Pistons, Valves, Rings and Bushings and Modernizing of Existing Locomotives. A new special committee has been appointed to report on Springs—Shop Manufacture and Repair, Including Design, Appliances and Repairs. The committees on Powdered Fuel and Specifications and Tests for Materials, which reported as special committees last year, have been made standing committees.

The personnel of the committees remains practically the same, there being two new members added to the standing committee on Powdered Fuel, one to the special committee on Locomotive Headlights, two to the special committee on Design, Maintenance and Operation of Electric Rolling Stock, and one to the committee on Train Resistance and Tonnage Rating. The special committee on Co-operation with Other Railway Mechanical Organizations has been practically revised, only two of the members serving last year remaining on the committee this year. The following is a list of the committees and their personnel:

STANDING COMMITTEES

1. **Standards and Recommended Practice:**  
W. E. Dunham (Chairman), Supr. M. P. & M., C. & N. W.; M. H. Haig, M. E., A. T. & S. P.; A. G. Trumbull, Asst. to G. M. S., Erie; C. D. Young, Engr. Tests, Penna.; G. S. Goodwin, M. E., C. R. I. & P.; R. L. Ettenger, C. M. E., Southern; B. B. Milner, Engr. M. P., N. Y. C.
2. **Mechanical Stokers:**  
A. Kearney (Chairman), A. S. M. P., N. & W.; M. A. Kinney, S. M. P., Hocking Valley; J. R. Gould, S. M. P., C. & O.; J. T. Carroll, A. G. S. M. P., Balto. & Ohio; J. W. Cyr, S. M. P., C. B. & O.; A. J. Fries, A. S. M. P., N. Y. Central Lines; L. B. Jones, A. E. M. P., Penna.
3. **Fuel Economy and Smoke Prevention:**  
Wm. Schlafge (Chairman), G. M. S., Erie; W. H. Flynn, S. M. P., Mich. Central; D. M. Perine, S. M. P., Penna.; Robert Quayle, G. S. M. P. & C., C. & N. W.; D. J. Redding, A. S. M. P., P. & L. E.; W. J. Tollerton, G. M. S., C. R. I. & P.; F. H. Clark, G. S. M. P., B. & O.
4. **Powdered Fuel:**  
C. H. Hogan (Chairman), A. S. M. P., N. Y. C.; E. W. Pratt, A. S. M. P., C. & N. W.; Thos. Roope, S. M. P., C. B. & O.; J. H. Manning, S. M. P., D. & H.; Charles James, M. S., Erie; G. L. Fowler, 83 Fulton street, New York City; W. L. Kellogg, S. M. P., M. K. & T.; O. S. Beyer, University of Illinois, Urbana, Ill.
5. **Specifications and Tests for Materials:**  
C. D. Young (Chairman), Engr. Tests, Penna.; J. R. Onderdonk, Engr. Tests, B. & O.; A. H. Fettes, M. E., Union Pac.; Frank Zeleny, Engr. Tests, C. B. & O.; H. E. Smith, Engr. Tests, N. Y. C.; H. B. MacFarland, Engr. Tests, A. T. & S. P.; Prof. L. S. Randolph, Virginia Polytechnic Institute, Blacksburg, Va.

SPECIAL COMMITTEES

6. **Design and Maintenance of Locomotive Boilers:**  
C. E. Fuller (Chairman), S. M. P., Union Pacific; A. W. Gibbs, C. M. E., Penna.; D. R. MacBain, S. M. P., New York Central; M. K. Barnum, S. M. P., Balto. & Ohio; R. E. Smith, G. S. M. P., Atlantic Coast Line; C. B. Young, M. E., Clgo. Bur. & Quincy; J. Snowden Bell, New York City.

7. **Locomotive Headlights:**  
D. F. Crawford (Chairman), G. S. M. P., Penna. Lines; C. H. Rae, G. M. M., L. & N.; F. A. Torrey, G. S. M. P., C. B. & O.; H. T. Bentley, S. M. P. & M., C. & N. W.; M. K. Barnum, S. M. P., Balto. & Ohio; Henry Bartlett, G. M. S., B. & M.; W. H. Flynn, S. M. P., Mich. Central; W. O. Moody, M. E., Illinois Central; A. R. Ayers, S. M. P., N. Y. C. & St. L.
  8. **Superheater Locomotives:**  
W. J. Tollerton (Chairman), G. M. S., C. R. I. & P.; H. W. Coddington, Engr. Tests, N. & W.; C. H. Hogan, A. S. M. P., N. Y. C. & H. R.; R. W. Bell, G. S. M. P., Ill. Cent.; T. Roope, S. M. P., C. B. & O.; W. C. A. Henry, S. M. P., Penna. Lines; E. W. Pratt, A. S. M. P., C. & N. W.; G. M. Basford, 30 Church street, New York City.
  9. **Design, Maintenance and Operation of Electric Rolling Stock:**  
C. H. Quecrean (Chairman), New York Central; G. C. Bishop, S. M. P., Long Island; G. W. Wildin, M. S., N. Y. N. H. & H.; J. H. Davis, E. E. B. & O.; R. D. Hawkins, S. M. P., Great Northern; A. E. Manchester, S. M. P., C. M. & St. P.; T. W. Heintzelman, G. S. M. P., Southern Pacific; J. T. Wallis, G. S. M. P., Penna.; J. E. Pileher, M. E., N. & W.
  10. **Coöperation with Other Railway Mechanical Organizations:**  
D. R. MacBain (Chairman), S. M. P., New York Central; E. W. Pratt, A. S. M. P., C. & N. W.; C. A. Shaffer, G. T. I., Illinois Central; F. J. Barry, M. M., N. Y. O. & W.; E. S. Fitzsimmons, M. S., Erie; F. C. Pickard, M. M., D. L. & W.
  11. **Train Resistance and Tonnage Rating:**  
O. C. Wright (Chairman), A. E. M. P., Penna. Lines; H. C. Manchester, S. M. P., D. L. & W.; C. E. Chambers, S. M. P., C. R. R. of N. J.; J. H. Manning, S. M. P., D. & H.; Frank Zeleny, Engr. Tests, C. B. & O.; Prof. E. C. Schmidt, University of Illinois, Urbana, Ill.; Jos. Chidley, A. S. M. P., N. Y. C.; J. T. Carroll, A. G. S. M. P., B. & O.
  12. **Springs—Shop Manufacture and Repair, Including Design, Appliances and Repair:**  
M. F. Cox (Chairman), A. S. M. L. & N.; Eliot Sumner, S. M. P., Penna.; A. G. Trumbull, Asst. to G. M. S., Erie; E. W. Pratt, A. S. M. P., C. & N. W.; T. A. Foque, G. M. S., M. St. P. & S. S. M.; C. A. Gill, G. M. M., B. & O.; G. W. Rink, M. E., C. R. R. of N. J.
  13. **Subjects:**  
M. K. Barnum (Chairman), S. M. P., B. & O.; D. R. MacBain, S. M. P., New York Central; C. E. Fuller, S. M. P., Union Pacific.
  14. **Arrangements:**  
Wm. Schlafge, G. M. S., Erie; C. E. Chambers, S. M. P., C. R. R. of N. J.; E. H. Walker, Standard Coupler Co.
- Individual Papers:**  
Feed Water Heaters, by J. Snowden Bell; Welding Locomotive Tubes, Fire Box and Boiler Sheets, by D. R. MacBain.

The following list gives names of secretaries, dates of next or regular meetings and places of meeting of mechanical associations:

- AIR BRAKE ASSOCIATION.—F. M. Nellis, Room 3014, 165 Broadway, New York City. Convention, May 1-4, 1917, Memphis, Tenn.
- AMERICAN RAILROAD MASTER TINNERS', COPPERSMITHS' AND PIPEFITTERS' ASSOCIATION.—O. E. Schlink, 485 W. Fifth St., Peru, Ind.
- AMERICAN RAILWAY MASTER MECHANICS' ASSOCIATION.—J. W. Taylor, Karpen Building, Chicago.
- AMERICAN RAILWAY TOOL FOREMEN'S ASSOCIATION.—Owen D. Kinsey, Illinois, Central, Chicago.
- AMERICAN SOCIETY FOR TESTING MATERIALS.—Prof. E. Marburg, University of Pennsylvania, Philadelphia, Pa.
- AMERICAN SOCIETY OF MECHANICAL ENGINEERS.—Calvin W. Rice, 29 W. Thirty-ninth St., New York. Annual Meeting, December 5-8, 1916, New York.
- ASSOCIATION OF RAILWAY ELECTRICAL ENGINEERS.—Joseph A. Andreucetti, C. & N. W., Room 411, C. & N. W. Station, Chicago.
- CAR FOREMEN'S ASSOCIATION OF CHICAGO.—Aaron Kline, 841 Lawlor Ave., Chicago. Second Monday in month, except June, July and August, Hotel La Salle, Chicago.
- CHIEF INTERCHANGE CAR INSPECTORS' AND CAR FOREMEN'S ASSOCIATION.—W. R. McMunn, New York Central, Albany, N. Y.
- INTERNATIONAL RAILROAD MASTER BLACKSMITHS' ASSOCIATION.—A. L. Woodworth, C. H. & D., Lima, Ohio.
- INTERNATIONAL RAILWAY FUEL ASSOCIATION.—J. G. Crawford, 547 W. Jackson Blvd., Chicago. Convention, May, 1917, Chicago.
- INTERNATIONAL RAILWAY GENERAL FOREMEN'S ASSOCIATION.—William Hall, 1126 W. Broadway, Winona, Minn.
- MASTER BOILERMAKERS' ASSOCIATION.—Harry D. Vought, 95 Liberty St., New York.
- MASTER CAR BUILDERS' ASSOCIATION.—J. W. Taylor, Karpen Building, Chicago.
- MASTER CAR AND LOCOMOTIVE PAINTERS' ASSOCIATION OF U. S. AND CANADA.—A. P. Dane, B. & M., Reading, Mass.
- NIAGARA FRONTIER CAR MEN'S ASSOCIATION.—E. N. Frankenberger, 623 Brisbane Building, Buffalo, N. Y. Meetings, third Wednesday in month, New York Telephone Bldg., Buffalo, N. Y.
- RAILWAY STOREKEEPERS' ASSOCIATION.—J. P. Murphy, Box C, Collinwood, Ohio.
- TRAVELING ENGINEERS' ASSOCIATION.—W. O. Thompson, N. Y. C. R. R., Cleveland, Ohio.

RAILROAD CLUB MEETINGS

Club	Next Meeting	Title of Paper	Author	Secretary	Address
Canadian	Dec. 12, 1916	Notes on Heavy Electric Traction	J. A. Shaw	James Powell	P. O. Box 7, St. Lambert, Que.
Central	Jan. 12, 1917	Annual Meeting; Election of Officers	.....	Harry D. Vought	95 Liberty St., New York.
Cincinnati	Feb. 13, 1917	Demonstration of the Automatic Stop	Julian Beggs	H. Boutet	101 Carew Bldg., Cincinnati, Ohio.
New England	Dec. 12, 1916	.....	.....	Wm. Cade, Jr.	683 Atlantic Ave., Boston, Mass.
New York	Dec. 15, 1916	Annual Smoker and Entertainment	.....	Harry D. Vought	95 Liberty St., New York.
Pittsburgh	.....	.....	.....	I. B. Anderson	207 Penn Station, Pittsburgh, Pa.
Richmond	Dec. 11, 1916	Electric Headlights	L. C. Porter	F. O. Robinson	C. & O. Railway, Richmond, Va.
St. Louis	Dec. 11, 1916	Address and Annual Entertainment	A. Ross Hill	B. W. Frauenthal	Union Station, St. Louis, Mo.
South'n & S'w'rn.	Jan. 19, 1917	.....	.....	A. J. Merrill	Box 1205, Atlanta, Ga.
Western	Dec. 18, 1916	.....	.....	Jos. W. Taylor	1112 Karpen Bldg., Chicago.

## PERSONAL

### GENERAL

M. J. FLANIGAN, who was recently appointed master mechanic of the Minot division of the Great Northern at Minot, S. Dak., has been appointed general master mechanic with headquarters at Great Falls, Mont.

H. G. REID, heretofore master mechanic, district 3, Transcontinental division of the Canadian Government Railways at Transcona, Man., has been appointed assistant superintendent of rolling stock with headquarters at that point, having direct charge of the Transcona shops, and will perform such other duties as may be assigned to him.

F. W. TAYLOR, superintendent of motive power of the International & Great Northern, has been appointed superintendent of motive power of the Missouri, Kansas & Texas, at Denison, Texas, effective February 1, 1917, succeeding W. L. Kellogg, who has resigned, effective at that time.

### MASTER MECHANICS AND ROAD FOREMEN OF ENGINES

JOHN BIRSE, road foreman of locomotives of the Canadian Government Railways at Graham, Ont., has been appointed district master mechanic, district 3, Transcontinental division, with headquarters at Transcona, Man., and his former position has been abolished.

ALBERT H. KENDALL, whose appointment as master mechanic of the Canadian Pacific was announced in the November issue of the *Railway Mechanical Engineer*, was born at Aspatria, Cumberland, England, on April 4, 1878, and began his railroad career in June, 1901, with the Canadian Pacific as machinist at Revelstoke. He remained in this capacity until March, 1902, when he became locomotive foreman at Nakusp, B. C. From January, 1903, to December, 1903, he was general foreman at Revelstoke, then leaving the Canadian Pacific to become locomotive foreman for the Grand Trunk at London, Ontario. In December, 1904, he returned to the Canadian Pacific and later was appointed general erecting foreman at the Angus shops. In April, 1915, he became general foreman at North Bay, Ont., and in August, 1916, was made assistant works manager at the Angus shops. He had the latter position at the time of his appointment as master mechanic.

F. A. BUTLER has been appointed master mechanic of the Albany division of the Boston & Albany, which includes the main line and branches between Springfield, Mass., and Albany, N. Y., succeeding J. B. Canfield, assigned to other duties. Mr. Butler was born in Shrewsbury, Mass., September 21, 1868. He entered the service of the Boston & Albany at Springfield in June, 1892, as a locomotive fireman, became locomotive engineer in November, 1898, and was appointed road foreman of engines of the Boston division in June, 1908. He was made master mechanic of the Boston division in August, 1910, so continuing until November 1, 1916, when he was appointed master mechanic of the Albany division at West Springfield, Mass.



A. H. Kendall

B. J. FARR, general foreman of the Grand Trunk, who was recently promoted to master mechanic, with office at Battle Creek, Mich., graduated from the high school at St. Albans, Vt., in 1893, and immediately entered railway service with the Central Vermont as a machinist apprentice. Later he was promoted to erecting shop foreman, and general foreman of the shop with this same company. In 1907 he left the service of the Central Vermont to accept a position on the Northern Railway of Costa Rica, where he remained until 1909. About this time the opportunity to acquire broader railroad experience presented itself, and he resigned to enter government service on the Panama Railroad at the time the Panama Canal was being constructed. He served in various capacities with this company until 1914, when he returned to the United States and entered the service of the Grand Trunk as general foreman in January, 1915. His present appointment as master mechanic became effective October 1, 1916.

F. A. HUSSEY has been appointed master mechanic of the Boston division of the Boston & Albany, with headquarters at Beacon Park, Allston, Mass., succeeding F. A. Butler, promoted. Mr. Hussey was born at Lynn, Mass., February 12, 1870. He entered the service of the Boston & Albany at Boston, in July, 1892, as a locomotive fireman and was promoted to locomotive engineer in December, 1902. He was appointed road foreman of engines of the Boston division of the Boston & Albany in April, 1913, holding the latter position at the time of his recent appointment.

CHARLES LEAT has been appointed road foreman of engines on the Atchison, Topeka & Santa Fe, Eastern division, with office at Argentine, Kan., succeeding A. F. Bauer.

WILLIAM B. SMITH has been appointed road foreman of engines on the Boston division of the Boston & Albany with headquarters at Beacon Park yard, Allston, Mass., succeeding F. A. Hussey, promoted. Mr. Smith has been a locomotive engineer on the Boston & Albany since 1897.

### CAR DEPARTMENT

FRANK S. BOGAN, formerly assistant car foreman of the Illinois Central, has been appointed general car foreman at Clinton, Ill.

W. A. CARTER, formerly passenger car foreman of the Illinois Central, has been appointed steam heat and air brake inspector of the Southern lines with office at Memphis, Tenn.

R. D. McCULLOUGH, formerly gang foreman of the Illinois Central, has been appointed assistant car foreman at Centralia, Ill.

JAMES PORTEOUS, heretofore car inspector for the Grand Trunk Pacific at Smithers, B. C., has been appointed car foreman at that point, succeeding F. E. Dymond, transferred.

### SHOP AND ENGINEHOUSE

JOHN D. ROGERS, recently appointed superintendent of shops of the Virginian Railway with headquarters at Princeton, W. Va., was born at Lexington, Va., on December 31, 1896. He graduated from the Virginia Polytechnic Institute in 1906 and in the same year entered the service of the Chesapeake & Ohio as a machinist apprentice. Later, until 1909, he was a machinist for the Virginian Railway. He graduated as a mechanical engineer from Cornell University in 1909 and subsequently, until 1911, was inspector of new cars and material for the Virginian Railway, from 1911 to 1912 serving as inspector of new locomotives at the works of the builders. In 1912 he was appointed roundhouse foreman of the Virginian Railway, leaving this road in 1915 to enter the service of the Oregon Short Line at Pocatello, Idaho, in a similar capacity. In June, 1916, he became general foreman of the Pere Marquette at Detroit, Mich., and in September, 1916, again entered the service of the Virginian Railway, as superintendent of shops.



WILLIAM J. TRACY has been appointed superintendent of shops of the Lehigh Valley at Sayre, Pa., succeeding J. C. Seeger, who has resigned. Mr. Tracy, who is a native of Wilkes-Barre, was an apprentice and learned his trade as a machinist in the old Wilkes-Barre shops of the Lehigh Valley. In 1904 he left this road to go to the Southern Railway where he became a foreman in the shops at Atlanta, later being appointed master mechanic of the Atlanta division. In 1905 he went to the Louisville & Nashville as master mechanic and shop superintendent at South Louisville, Ky., opening and organizing the shops at that point. In 1908 Mr. Tracy was appointed assistant superintendent of motive power of the Missouri Pacific at Kansas City, where he remained until January 31 of this year, when he left the service of the Missouri Pacific. He took up his new duties on November 1.

**PURCHASING AND STOREKEEPING**

C. D. CLAPP has been appointed purchasing agent of the Mississippi Central, with office at Hattiesburg, Miss.

W. R. CULVER, storekeeper of the Pere Marquette at Grand Rapids, Mich., has been appointed general storekeeper. The office of general storekeeper is now located at Saginaw, Mich.

J. P. HARRISON, assistant purchasing agent of the Louisville & Nashville, at Louisville, Ky., has been appointed purchasing agent, succeeding P. P. Huston, retired.

H. T. SHANKS has been appointed assistant purchasing agent of the Louisville & Nashville, at Louisville, Ky., succeeding J. P. Harrison, who has been promoted.

P. J. SHEA has been appointed general storekeeper of the Boston & Albany, with headquarters at West Springfield, Mass., succeeding E. B. Rockwood, resigned.

M. E. TOWNER has been appointed purchasing agent of the Western Maryland, with headquarters at Baltimore, Md. Mr. Towner was born October 3, 1875, at Branford, Conn.,



M. E. Towner

where he received his early education. He entered railway service on September 1, 1894, with the New York, New Haven & Hartford, in the general auditing department at New Haven, Conn., being transferred to New York City on July 1, 1902, as a clerk in the purchasing department. On May 31, 1907, he was appointed assistant to the vice-president of the Chicago, Rock Island & Pacific at Chicago, Ill., and on July 3, 1908, became purchasing agent of the St. Louis & San Francisco, at St. Louis, Mo. He resigned this latter connection in July, 1910, to assume the presidency of the Southern Railway Supply Company. On May 1, 1914, he was appointed special representative of the Whitman & Barnes Company, with offices at St. Louis, Mo., which position he held at the time of his appointment as purchasing agent of the Western Maryland, on November 1.

**OBITUARY**

WILLIAM ARNOLD ANGELL, formerly purchasing agent of the Pullman Company, and before that for many years first assistant to the late George M. Pullman, died at his home

in Chicago on the evening of November 14, aged 84 years.

THEODORE N. ELY, formerly chief of motive power of the Pennsylvania Railroad System, including the lines both east and west of Pittsburgh and Erie, whose death was announced



Theodore N. Ely

in these columns last month, was born June 23, 1846, at Watertown, N. Y., and was graduated from the Rensselaer Polytechnic Institute in 1866, as a civil engineer. Immediately after graduation he was engaged as an engineer at the old Fort Pitt foundry at Pittsburgh, experimenting with projectiles. A year later, 1867, he was at work in mining operations in the Monongahela river region. In 1868 he entered upon his long career in the service of the Pennsylvania

Railroad as an engineer in the roadway department on the Pittsburgh, Fort Wayne & Chicago at Pittsburgh, from which he was soon sent as assistant engineer to the Philadelphia & Erie division of the Pennsylvania. In 1869 and 1870 he was superintendent of the Middle division of the Philadelphia & Erie, and was then promoted to assistant general superintendent, a position which he held until 1873. From 1873 to 1874 he was superintendent of motive power of the same division. In 1874 he was made superintendent of motive power of the Pennsylvania Railroad division, and in 1882 became general superintendent of motive power of the Pennsylvania lines east of Pittsburgh and Erie. From March, 1893, to the date of his retirement he was chief of motive power, Pennsylvania lines east and west of Pittsburgh and Erie.

Mr. Ely was a member of the American Society of Civil Engineers, the Institution of Civil Engineers (England), the American Society of Mechanical Engineers, the American Institute of Mining Engineers, the Franklin Institute, the American Philosophical Society, the American Association for the Advancement of Science, and other technical and scientific associations. He was a lover and patron of art and had a wide circle of friends in that field. He was vice-president of the American Academy in Rome, and an honorary member of the American Institute of Architects. He was president of the Eastern Railroad Association for several years, and also a member of the executive committee of the American Railway Association and of the permanent commission of the International Railway Congress; also of the boards of trustees of the Drexel Institute of Art, Science, and Industry, and of the Philadelphia Commercial Museum. The honorary degree of Master of Arts was conferred upon Mr. Ely, in 1897, by Yale University, and that of Doctor of Science by Hamilton College in 1904.

The great work of Mr. Ely's life was performed in the mechanical department of the Pennsylvania Railroad, at the Altoona (Pa.) shops, where he inaugurated the department for testing materials, and established the system of purchasing supplies on rigid specifications. This was a new field at that time in railroad work and Mr. Ely encountered much opposition, but he acted on the courage of his convictions, and lived to see the system of specifications, which he inaugurated, adopted by many other railroads. As a result of his work at Altoona, the plan of purchasing railroad supplies on specifications has now become general, to the benefit of both buyer and seller.

## SUPPLY TRADE NOTES

The Northwest Steel Company, Portland, Ore., has under consideration the erection of a new \$1,000,000 rolling mill, with a capacity of 20,000 tons of steel per month.

Frank L. Severance has been appointed general manager of the Irving-Pitt Manufacturing Company, Kansas City, and H. R. McCleary has been appointed general sales manager.

R. H. Wood, for a number of years connected with the Buffalo office of the Warner & Swasey Company, Cleveland, Ohio, has been appointed manager of the Chicago district office of the Modern Tool Company, Erie, Pa.

Fay E. Possom, formerly connected with the sales department of the Grip Nut Company, Chicago, Ill., has been elected vice-president of the Safety First Manufacturing Company, western representative for several different railway specialties.

Herbert W. Dow, assistant sales engineer of the Nordberg Manufacturing Company, Milwaukee, Wis., has been appointed sales manager succeeding Fred W. O'Neil, who resigned to accept an executive position with the Ingersoll-Rand Company, New York.

The Burdett Oxygen Company, Chicago, Ill., will complete the erection of its Pittsburgh, Pa., plant, at Fortieth street and the Allegheny Valley tracks, on December 1. This will make the eleventh plant to be established by this company in the various industrial centers of the country.

Leo C. Steinle has been appointed direct representative in France of the Modern Tool Company, Erie, Pa., with offices at Paris and Lyons. Mr. Steinle is actively connected with the Steinle Turret Machine Company, Madison, Wis., whose interests he is also looking after abroad.

Robert D. Sinclair, first vice-president of Mudge & Co., Chicago, has been appointed vice-president, in charge of the sales, manufacturing and treasury departments. Mr. Sinclair was born at Chicago on April 12, 1878, and entered railway service in the auditing department of the Chicago & Eastern Illinois in 1892. The following year he accepted a position with the operating department of the Columbian Intramural Railway at the Chicago World's Fair. At the close of this exposition he entered the service of the Union National Bank of Chicago, and remained with it until its consolidation with the First National Bank in 1900, when he went with the larger institution. He left the banking business on September 1, 1910, to become secretary and treasurer of Mudge & Co. On June 9, 1912, he was elected second vice-president of this company, later being made first vice-president. On November 1, 1916, he was appointed vice-president in charge of all departments, as noted above.

Sydney Dillon has been appointed chief mechanical engineer of the Carnegie Steel Company, succeeding John Hulst, who was recently appointed assistant to the vice-president and chief engineer of the United States Steel Corporation.

Mr. Dillon has been with the Carnegie Steel Company since 1889.

The Lagonda Manufacturing Company, Springfield, Ohio, announces the opening of a new branch office in the McCormick building, Chicago. J. E. Chubb, formerly with the Griscom-Russell Company, is in charge as district sales manager. The company's business in this territory was formerly in charge of the Chicago Engineer Supply Company.

William Cooper Cuntz, general manager and director of the Goldschmidt Thermit Company, New York, died on November 2, at Auburndale, Mass., where he was on a visit for the benefit of his health which was impaired by an operation for appendicitis a year ago. Mr. Cuntz was born in Hoboken, N. J., in 1871. He attended the Hoboken Academy and Stevens Institute of Technology, graduating in 1892 with the degree of mechanical engineer. He then became connected with the Pennsylvania Steel Company of Steelton, Pa., first with the bridge and construction department and later with the sales department, which he represented in Boston, Philadelphia, London, England, and in Steelton. He was at one time assistant sales manager at Philadelphia and later sales agent with headquarters at Steelton. In 1910 he was appointed by President Taft a delegate to the International Railway Congress at Berne, Switzerland. In the same year he severed his connections with the Pennsylvania Steel Company to become a director and general manager of the Goldschmidt Thermit Company, New York. At the time of his death he was also a director of the Goldschmidt Detinning Company.



W. C. Cuntz

Announcement has been made by the Westinghouse Electric & Manufacturing Company of an extension of its present bonus system to include salaried and office employees on hourly rates, by which they will receive a bonus of 8 per cent of their salary each month providing their total excusable time absent and late during the month does not exceed six hours incurred on not over three occasions.

W. F. Caspers, western sales representative for the Monarch Steel Castings Company, of Detroit, Mich., has been appointed sales representative for the Aurora Foundries Company and the Fox River Iron Company, manufacturers of brake shoes, babbit metals, journal bearings and railway castings. Mr. Caspers will have headquarters at 707-708 Transportation building, Chicago, Ill.

Charles Lounsbury has recently been made president and general manager of the American Railway Supply Company, 134 Charles street, New York. Mr. Lounsbury was born in New York City in 1863 and is a graduate of the College of the City of New York. He began his business career in 1887 with the American Railway Supply Company as junior clerk and has been with that company in various capacities ever since.

The Chicago Car Heating Company, Chicago, has issued the following: "The long continued steam hose coupler patent litigation between Chicago Car Heating Company and



R. D. Sinclair

Gold Car Heating & Lighting Company has been ended by a decision rendered on October 3, 1916, by the United States Circuit Court of Appeals at Chicago in favor of Chicago Car Heating Company. As there is no appeal, this decision ends this controversy in favor of Chicago Car Heating Company."

William Barlow Ross, secretary and assistant treasurer of Mudge & Co., manufacturers of railway specialties, Chicago, has also been elected secretary and assistant treasurer of the Safety First Manufacturing Company, selling agents for railway supplies, with the same headquarters.



W. B. Ross

Mr. Ross was born on December 24, 1868, at Belfast, Ireland, and was educated in Manchester, England. He came to America in April, 1889, and entered railway service with the Burlington, Cedar Rapids & Northern, as a trucker and checker at Cedar Rapids, Iowa. He was later transferred to the auditor's office, where he remained in various capacities until December, 1892. He was then appointed timekeeper in the superintendent's office, and later chief clerk. From June 30, 1895, to August 31, 1901, he was utility clerk to the vice-president and general superintendent, being then promoted to car accountant. When the Burlington, Cedar Rapids & Northern was absorbed by the Chicago, Rock Island & Pacific in June, 1902, he was made car agent. The following January he was appointed statistician to the general manager of the system. In September, 1903, he was appointed transportation clerk to the third vice-president, and up to December, 1909, was consecutively transportation clerk to the president, statistician to the president and chief clerk to the standardization committee. On January 1, 1910, he was elected secretary of the board of pensions, and later was made secretary of the pension and personal record bureau. On July 1, 1916, he resigned to become secretary and assistant treasurer of Mudge & Co.

J. A. & W. Bird & Co., Boston, Mass., distributors of Ripolin Enamel paint, have arranged to have George Price, manager of the New York office, 120 Broadway, handling the metropolitan district for the past eight years, and who recently completed a trip through the south, engineer and handle the sales department covering the entire territory south of New York, as far west as the Mississippi, and also including Louisiana and Texas.

A group of bankers, including Frank A. Vanderlip, Philip W. Henry, Thatcher M. Brown, and Franklin B. Kirkbride, of New York, and Marcus Wallenberg, of Stockholm, have recently acquired from the American group of stockholders a controlling interest in the shares of the Hess-Bright Manufacturing Company. This group of bankers owns also a substantial interest in the S. K. F. Ball Bearing Company of Hartford, Connecticut. The two companies will be operated quite independently of each other.

Judge Hazel, sitting in the district court for the western district of New York, on October 17 handed down a decision in the case of the Safety Car Heating & Lighting Company vs. U. S. Light & Heat Corporation, in which he held that the latter's car lighting equipment did not infringe the Creveling patent owned by the plaintiff, but was manufactured under

the McElroy patents owned by the United States Company. He also dismissed a counter claim declaring that the Safety Type F system of the Safety Company was an infringement of the McElroy patents.

The increased demand for its line of hydraulic equipment has led to the completion of plans for extensive plant and equipment improvements in the factory of The Hydraulic Press Mfg. Co., Mount Gilead, Ohio. To relieve the crowded condition of the machine shop, an addition 100 ft. long by 60 ft. wide will be erected; a 20-ft. extension will be added to the present power plant building and the main stock room will be extended and another story added. The tool room will also be extended and a new structural shop built.

Hugh E. Creer, formerly sales agent for the Union Railway Equipment Company, Chicago, Ill., has been appointed general sales representative of the Camel Company, manufacturers of railway specialties, with headquarters in Chicago. He was born in Hardin, Ray County, Mo., in August, 1874. In 1898, he took employment with the Missouri Pacific at Osawatomie, Kan., and in the following year entered the car department of the St. Louis, Iron Mountain & Southern, where he remained until 1904, consecutively as car repairer, inspector, chief clerk, assistant foreman and foreman of freight car repairs. In August, 1904, he left railway work, but returned in September, 1905, as car foreman of the Pere Marquette at Muskegon, Mich. In January, 1907, he was promoted to general foreman of the car department, and in August, 1910, entered the service of the Missouri Pacific as division foreman in the car department at Atchison, Kan. In March, 1911, he took a position with McCord & Company, of Chicago, as mechanical expert, and in March, 1916, joined the sales forces of the Union Railway Equipment Company.

D. P. Lameroux has been appointed general manager of the Pratt & Letchworth Company, Ltd., Brantford, Ont. Mr. Lameroux was born in Mayville, Wis., December 12, 1873.



D. P. Lameroux

He received his education at the University of Wisconsin, where he took a course in civil engineering as a member in the class of 1895. After leaving college he spent two years in the maintenance department of the Milwaukee Northern Railway, and the California Oregon Railway, and for the following three years was private secretary to the commissioner of the general land office at Washington, D. C. In 1900, he became associated with the Beaver Dam Malle-

able Iron Company and worked his way up through that organization until, in 1913, when he left to take up another position, he was the company's general manager. During this period, also, he was on the executive legislative committee of the Wisconsin Manufacturers' Association, and for three years of this time was also regent of the University of Wisconsin. In 1913 he entered the railway supply business in Chicago, and was connected with the Cleveland Steel Company and the Trumbull Steel Company. In his new position he will act as general manager of the various malleable plants of the Canadian Car & Foundry, Limited, including the Pratt & Letchworth Company's plant at Brantford and the Malleable iron plant at Amherst.

Frederick W. Bright, superintendent of motive power, Armour & Company, died at his home in Chicago, Ill., Sunday, October 29. He was born in Barry, Ill., where he received his early education. On attaining young manhood he entered the service of Armour & Company in the mechanical department as an apprentice, being sent to the Kansas City plant, where he remained for 26 years, and during which time he was promoted in turn to every position in this department. At the time of his death Mr. Bright was in charge of all the mechanical and engineering work of Armour & Company.

J. Sterling Goddard, for the past 10 years chief engineer for the American Steel Foundries, Chicago, died at his home in Riverside, Ill., on November 23, at the age of 44. He was born on August 15, 1872, at Monroe, Mich. He graduated from the mechanical engineering department of Cornell University in 1894, and took employment at once with the Western Tube Company, Kewanee, Ill., as an assistant mechanical engineer. He held this position until April, 1898, when he entered the engineering department of the Frazer & Chalmers Company. In 1900 he was appointed chief draftsman in the motive power department of the Chicago, Burlington & Quincy at Chicago, and retained this position until 1906, when he was appointed chief engineer of the American Steel Foundries.

Edward Thomas Hendee, secretary of Joseph T. Ryerson & Son, Chicago, died suddenly at Minneapolis, Minn., on November 12. He was born at Claremont, N. H., on February 22, 1880, and graduated from New York University in 1900. From 1901 to 1902 he was assistant professor of mechanical engineering at New York University. On the latter date he became associated with Joseph T. Ryerson & Son, Chicago, as advertising manager and also built up and became manager of the machinery department. He was made assistant to the president in January, 1911, and in 1913 he assumed charge of the railway supply department. In the same year he was elected secretary of Joseph T. Ryerson & Son. He was particularly successful in developing the domestic and foreign machinery business and the railway supply business of his company. Mr. Hendee was also vice-president and director of the Lehigh Machine Company and director of the American-Glyco Metal Company.



J. S. Goddard

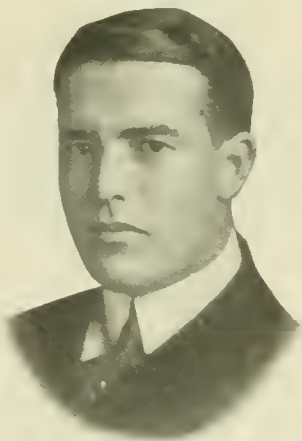

E. T. Hendee

## CATALOGUES

**PNEUMATIC TOOLS.**—Bulletin No. 130, recently issued by the Chicago Pneumatic Tool Company, takes up the subject of lubrication of pneumatic tools.

**TAPS.**—Bulletin No. 34, recently issued by the Modern Tool Company, Erie, Pa., is a four-page folder detailing the special features, and containing a description and illustrations of Modern collapsible taps.

**GAS ENGINE.**—Bulletin 34-x, recently issued by the Chicago Pneumatic Tool Company, deals with Giant gas engines. The booklet describes in detail the engine and its various parts and is well illustrated.

**ADJUSTABLE REAMERS.**—Catalogue G recently issued by the Kelly Reamer Company, Cleveland, Ohio, is entitled Kelly Production Tools and is a catalogue of the reamers, adjustable high speed blades and similar tools made by the company.

**MACHINE TOOLS.**—Catalogue No. 51 recently issued by the Newton Machine Tool Works, Inc., Philadelphia, gives specifications, dimension tables and illustrations of the Newton cold saw cutting-off machines. The booklet also contains a number of illustrations showing machines in actual service and a supplementary section is devoted to various milling, slotting and drilling machines.

**SIMPLEX JACKS.**—Templeton, Kenly & Co., Ltd., Chicago, has issued a 32-page pamphlet illustrating and describing the simplex jack and its application to various industrial purposes. Of special interest to railway men is the application of these jacks to car repairs, the several designs of track jacks and the Simplex Pole jack, designed for placing, straightening or pulling telephone, telegraph or power line poles.

**PULVERIZED COAL EQUIPMENT.**—This is the title of catalogue No. 71 recently issued by the Lehigh Car Wheel & Axle Works, Fullerton, Pa. The booklet is 8 in. by 10½ in. in size, and contains 28 pages. It gives descriptions and illustrations of the following units used for the production of pulverized coal: The Fuller-Lehigh pulverizer mill, Lehigh coal crushing rolls; indirect fired rotary dryers; pulverized coal feeders, and Fuller quality sprockets.

**GRINDING WHEELS.**—The Star Corundum Wheel Company, Detroit, Mich., has issued a catalogue showing its line of Star grinding wheels. The book contains 100 pages and in them it illustrates its various types of grinding wheels, noting for what uses they are intended and giving dimensions, price lists and code words. Much useful information is also given as to speeds, mounting, grains, grades, etc. With the catalogue the company is also sending out a 16-page booklet entitled: Safety Code for the Use and Care of Abrasive Wheels.

**FEED WATER TREATMENT.**—One of the latest publications of the Dearborn Chemical Company, Chicago, bears the title, "Incrustation, Corrosion, Foaming and Other Effects of Water Used in Steam Making and Methods of Prevention." The booklet first emphasizes that the Dearborn Chemical Company does not supply a "cure-all," and that it is not a "boiler compound house." The book in three chapters takes up respectively the subjects of corrosion, including pitting, grooving and electrolysis; incrustation, including soft and hard scale of varying compositions; and foaming, including priming, bagging, causes of explosion, etc., with a discussion of oil in boilers. One section deals with the Dearborn Chemical Company itself, showing how its experts make analyses, work out formulas and compound the proper remedies. The book is well illustrated, several pictures showing parts of the office and plant.











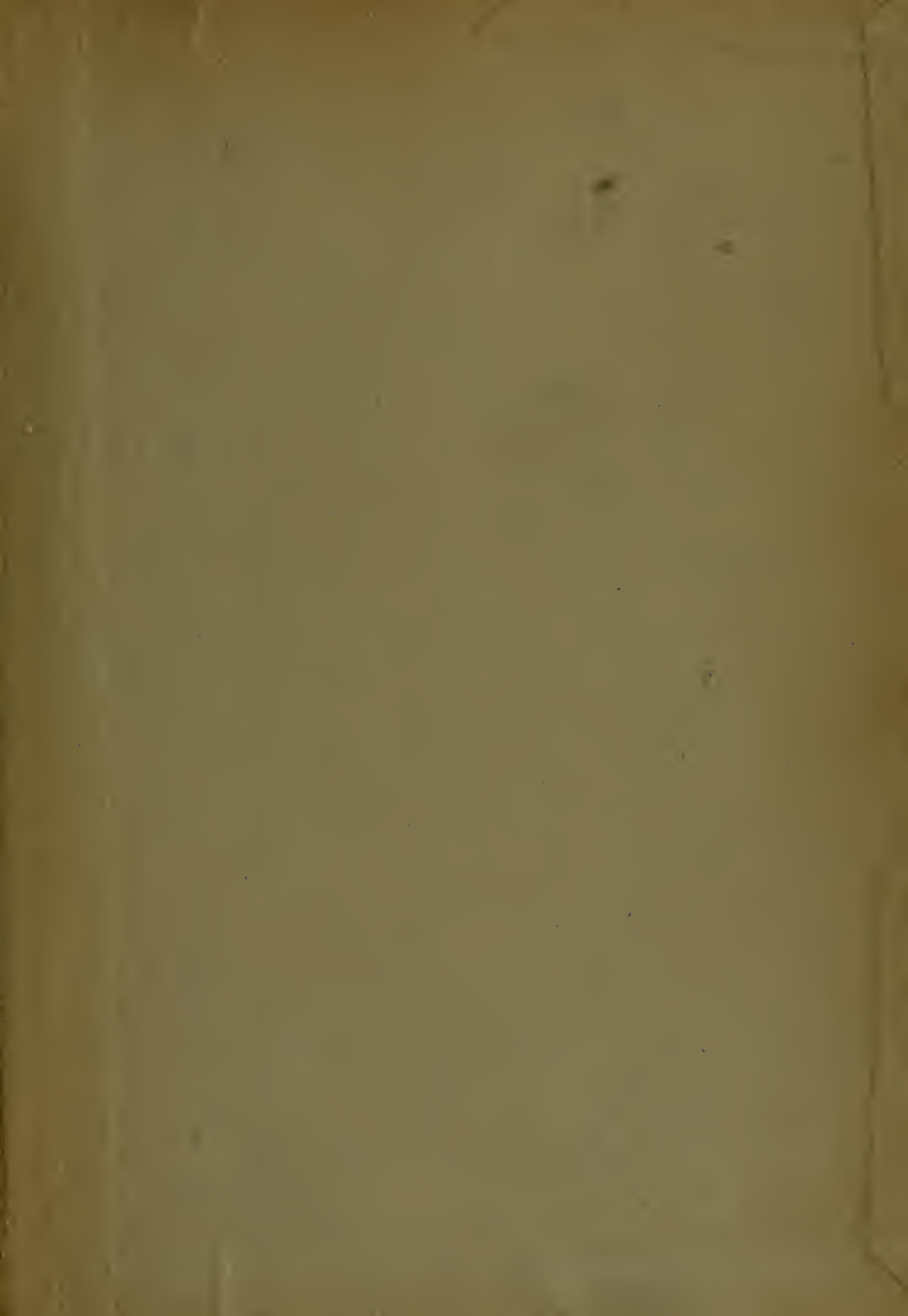

CARNEGIE LIBRARY OF PITTSBURGH



3 1812 04296 1194

