

anxaf
87-B
17866

DIOSPOLIS PARVA

THE CEMETERIES OF ABADIYEH AND HU

1898-9

BY

W. M. FLINDERS PETRIE

HON. D.C.L., LITT.D., LL.D., PH.D.,

EDWARDS PROFESSOR OF EGYPTOLOGY, UNIVERSITY COLLEGE, LONDON;
MEMBER OF THE IMPERIAL GERMAN ARCHAEOLOGICAL INSTITUTE;
CORRESPONDING MEMBER OF SOCIETY OF ANTHROPOLOGY, BERLIN;
MEMBER OF THE SOCIETY OF NORTHERN ANTIQUARIES.

With Chapters by

A. C. MACE

SPECIAL EXTRA PUBLICATION OF
THE EGYPT EXPLORATION FUND

PUBLISHED BY ORDER OF THE COMMITTEE

LONDON

SOLD AT

THE OFFICES OF THE EGYPT EXPLORATION FUND, 37, GREAT RUSSELL STREET, W.C.
AND 59, TEMPLE STREET, BOSTON, MASS., U.S.A.

AND BY KEGAN PAUL, TRENCH, TRÜBNER & CO., PATERNOSTER HOUSE, CHARING CROSS ROAD, W.C.
B. QUARITCH, 15, PICCADILLY, W.; ASHER & Co., 13, BEDFORD STREET, COVENT GARDEN, W.C.

—
1901

CLASS B
BLACK-TOPPED
POTTERY



CLASS P
POLISHED RED



CLASS F
FANCY FORMS



CLASS C
CROSS-LINED



CLASS N
INCISED BLACK



CLASS W
WAVY-HANDLED

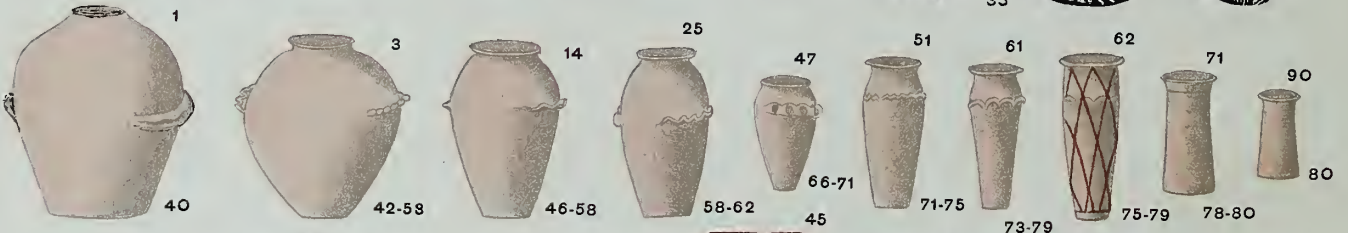

CLASS D
DECORATED



CLASS R
ROUGH-FACED



CLASS L
LATE



DIOSPOLIS PARVA

THE CEMETERIES OF ABADIYEH AND HU

1898-9

BY

W. M. FLINDERS PETRIE

HON. D.C.L., LITT.D., LL.D., PH.D.,

EDWARDS PROFESSOR OF EGYPTOLOGY, UNIVERSITY COLLEGE, LONDON;

MEMBER OF THE IMPERIAL GERMAN ARCHAEOLOGICAL INSTITUTE;

CORRESPONDING MEMBER OF SOCIETY OF ANTHROPOLOGY, BERLIN;

MEMBER OF THE SOCIETY OF NORTHERN ANTIQUARIES.

With Chapters by

A. C. MACE

SPECIAL EXTRA PUBLICATION OF

THE EGYPT EXPLORATION FUND

PUBLISHED BY ORDER OF THE COMMITTEE

LONDON

SOLD AT

THE OFFICES OF THE EGYPT EXPLORATION FUND, 37, GREAT RUSSELL STREET, W.C.

AND AT 59, TEMPLE STREET, BOSTON, MASS., U.S.A.

AND BY KEGAN PAUL, TRENCH, TRÜBNER & CO., PATERNOSTER HOUSE, CHARING CROSS ROAD, W.C.

B. QUARITCH, 15, PICCADILLY, W.; ASHER & Co., 13, BEDFORD STREET, COVENT GARDEN, W.C.

—
1901

LONDON:
PRINTED BY GILBERT AND RIVINGTON, LTD.
ST. JOHN'S HOUSE, CLERKENWELL.

EGYPT EXPLORATION FUND.

President.

SIR JOHN EVANS, K.C.B., D.C.L., LL.D., F.R.S.

Vice-Presidents.

SIR E. MAUNDE THOMPSON, K.C.B., D.C.L., LL.D.	THE HON. CHAS. L. HUTCHINSON (U.S.A.).
LT. - GENERAL SIR FRANCIS GRENFELL, G.C.M.G., G.C.B.	PROF. G. MASPERO, D.C.L. (France).
THE REV. PROF. A. H. SAYCE, M.A., LL.D.	PROF. AD. ERMAN, Ph.D. (Germany).
THE REV. W. C. WINSLOW, D.D., D.C.L. (U.S.A.).	JOSIAH MULLENS, Esq. (Australia).
	M. CHARLES HENTSCH (Switzerland).

Hon. Treasurers.

H. A. GRUEBER, Esq., F.S.A. F. C. FOSTER, Esq. (Boston, U.S.A.).

Hon. Secretaries.

J. S. COTTON, Esq., M.A. THE REV. W. C. WINSLOW, D.D. (Boston, U.S.A.).

Members of Committee.

T. H. BAYLIS, Esq., M.A., Q.C., V.D.	THE MARQUIS OF NORTHAMPTON.
MISS M. BRODRICK, Ph.D. (for Boston).	FRANCIS WM. PERCIVAL, Esq., M.A., F.S.A.
ARTHUR CATES, Esq., F.S.A.	PROF. W. M. F. PETRIE, D.C.L., LL.D.
SOMERS CLARKE, Esq., F.S.A.	F. G. HILTON PRICE, Esq., F.S.A.
W. E. CRUM, Esq., M.A.	MRS. CORNELIUS STEVENSON, Sc.D. (for Pennsylvania).
ARTHUR JOHN EVANS, Esq., M.A., F.S.A.	MRS. TIRARD.
F. LL. GRIFFITH, Esq., M.A., F.S.A.	THE REV. H. G. TOMKINS, M.A.
MRS. F. LL. GRIFFITH.	EMANUEL M. UNDERDOWN, Esq., Q.C.
T. FARMER HALL, Esq.	SIR HERMANN WEBER, Esq., M.D.
F. G. KENYON, Esq., M.A., Litt.D.	E. TOWRY WHYTE, Esq., F.S.A.
MRS. McCLURE.	MAJOR-GENERAL SIR CHARLES W. WILSON
THE REV. W. MACGREGOR, M.A.	K.C.B., K.C.M.G., F.R.S.
A. S. MURRAY, Esq., LL.D., F.S.A.	



Digitized by the Internet Archive
in 2014

<https://archive.org/details/diospolisparvace00petr>

CONTENTS.

SECT.	INTRODUCTION.	PAGE
1.	The work and site	1
2.	Previous prehistoric discoveries	2
CHAPTER I.		
THE SEQUENCE OF PREHISTORIC REMAINS.		
3.	The problem of sequences	4
4.	Sorting graves by degradation	5
5.	Extending a series by proportions	6
6.	Preliminary tabulation	6
7.	Final tabulation	7
8.	Ranges of Black-topped pottery	8
9.	„ Polished red pottery	9
10.	„ Fancy pottery	9
11.	„ Cross-lined pottery	9
12.	„ Incised pottery	10
13.	„ Wavy-handled pottery	10
14.	„ Decorated pottery	10
15.	„ Rough-faced pottery	10
16.	„ Late pottery	11
17.	Examples of dating of graves	11
18.	Results of sequence dating	12
CHAPTER II.		
THE POTTERY.		
19.	Black-topped pottery	13
20.	Polished red pottery	13
21.	Cross-lined pottery	14
22.	Fancy and incised pottery	14
23.	Wavy-handled pottery	15
24.	Decorated pottery	15
25.	Rough-faced pottery	16
26.	Late pottery	16
CHAPTER III.		
THE STONE VASES.		
SECT.		PAGE
27.	The forms	18
28.	The materials	19
CHAPTER IV.		
THE SLATE PALETTES AND IVORIES.		
29.	The forms	20
30.	The use of malachite	20
31.	Ivory combs and pins	21
32.	„ tusks	21
33.	Armlets and pendants	21
CHAPTER V.		
TOOLS OF STONE AND METAL.		
34.	Flaking and grinding	23
35.	Forms of flints	23
36.	Mace heads	24
37.	Copper tools	24
38.	„ ornaments	25
39.	Silver, gold, lead, &c.	25
CHAPTER VI.		
AMULETS AND BEADS.		
40.	Human figures	26
41.	Bull's head amulets	26
42.	Animal and other amulets	26
43.	Beads	27

CONTENTS.

CHAPTER VII.

OUTLINE OF THE PREHISTORIC PERIODS.

SECT.	PAGE
44. Beginning of cultivation	28
45. The earliest civilization	28
46. The later prehistoric people	29
47. Richest age and decline	30
48. Connection with the historic	30

CHAPTER VIII.

THE CEMETERIES.

49. The position of the cemeteries	31
50. The graves of cemetery B	32
51. Cemetery C	34
52. „ H	35
53. „ R	35
54. „ U	35

CHAPTER IX.

TOMBS OF THE VITH TO XITH DYNASTIES.

55. Cemetery D	37
56. „ N	38
57. „ W and characteristics	38
58. „ Y (Mr. Mace)	39
59. Steles	41

CHAPTER X.

TOMBS OF THE XIITH DYNASTY.

CEMETERIES W AND Y.

60. Characteristics of XII th Dynasty	42
61. Direction of tombs	42
62. Pre-Useratesen tombs, W	43
63. XII th Dynasty tombs, W	43
64. „ „ Y (Mr. Mace)	44

CHAPTER XI.

THE PAN GRAVES.

SECT.	PAGE
65. A new class of graves	45
66. The graves and bodies	45
67. The animal heads	46
68. Dress and ornaments	46
69. Utensils, &c.	47
70. XII th Dynasty objects	47
71. Pan-grave pottery	47
72. Black incised pottery	48
73. Dogs' graves	48
74. Age and source of the people	48

CHAPTER XII.

TOMBS OF XIIITH—XVIIITH DYNASTIES.

CEMETERY Y.

By Mr. Mace.

75. The Cemetery	50
76. Connections with XII th Dynasty	50
77. „ XVIII th Dynasty	51
78. „ Pan-graves	51
79. The graves	51
80. The pottery	51
81. The stone figures and vases	52
82. The copper implements	52
83. Other objects	52
84. Special graves	53
85. XVIII th Dynasty remains	53

CHAPTER XIII.

THE PTOLEMAIC AND ROMAN PERIOD.

86. Ptolemaic remains	54
87. The temple enclosure	54
88. Account by Nestor L'Hôte	55
89. Causeway, houses, &c.	55
90. Roman pottery and marks	56
91. Asianic ostrakon	56
92. Roman graffiti	57
93. Modelled head	57
INDEX	59

LIST OF PLATES

(WITH REFERENCES).

PLATE	PAGE	PLATE	PAGE
<i>Frontispiece.</i> Classes of prehistoric pottery	13-17	XXVI.	Figures of XIIth Dynasty 43, 52, 53
I. Map of cemeteries	31	XXVII.	Ornaments, &c., XIIth Dynasty 43, 53
II. Pottery of successive periods	5	XXVIII.	Stone vases, VIth—Xth Dynasties 36, 38-40
III. Sequence of stone vases, slate palettes, and ivories	18-22	XXIX.	„ XIIth Dynasty 42-4
IV. Sequence of flints, copper, beads, ensigns, and amulets	23-27	XXX.	Kohl vases „ 44, 52
V. Prehistoric groups	13, 32, 33, 36	XXXI.	Copper mirrors 37-44, 52
VI. „ „	21, 32-5	XXXII.	„ weapons, &c. 41, 44, 52
VII. „ flints	22-4, 32-6	XXXIII.	Pottery, VIth—XIIth Dynasties 39, 43, 44
VIII. „ „	23, 32-6	XXXIV.	„ XIIth—XVIIIth Dynasties 43
IX. Stone vases and ivories	18-21, 32-6	XXXV.	„ of cemetery Y 51, 52
X. Ivories	21-4	XXXVI.	„ „ „ 51, 52
XI. Slate palettes	20, 32-6	XXXVII.	Marks on pottery, Y 51, 52
XII. „	20, 32-6	XXXVIII.	Pan grave, E 2 45
XIII. Pottery, Classes B and P	13	XXXIX.	Pan graves, Egyptian pottery 46, 47
XIV. „ „ F, C, and N	14	XL.	Pan graves, pottery 47
XV. „ „ W and D	15	XLI.	Scarabs, cartonnage, &c. 39, 41, 44, 56
XVI. „ „ D	15	XLII.	Figures, Ptolemaic and Roman 54-57
XVII. „ „ R	16	XLIII.	Ptolemaic temple blocks 54
XVIII. „ „ L	16	XLIV.	Roman drawings 57
XIX. „ „ L	17	XLV.	Marks on Roman pottery 56
XX. Marks on pottery	29	XLVI.	„ „ „ 56
XXI. „ „	29	XLVII.	„ „ „ 56
XXII. „ „	29	XLVIII.	„ „ „ 56
XXIII. „ „	29		
XXIV. Plan, cemet. D and Fort	37, 54-6		
XXV. Objects of VIth—XIth Dynasties	37, 41, 43, 52		

DIOSPOLIS PARVA.

INTRODUCTION.

1. THE present volume has been delayed owing to the great importance of the subsequent work on the Royal Tombs of Abydos, which made it desirable to issue the account of the remains of the Ist Dynasty as soon as possible. This volume, though delayed, is, however, one of the most essential to our view of the past, as the whole subject of the prehistoric age of Egypt is for the first time classified and reduced to order.

In dealing with the prehistoric age it has been difficult to state enough of what is already known without repeating too much. To place any one in possession of the facts and materials it would be needful to repeat nearly all of the eighty-six plates of my volume on *Nagada*, published in 1896 by Quaritch. Yet as the time has not yet come for a final corpus of all that is known completely systematized, it would be undesirable to go to the expense of repeating so much material at present. It is, therefore, necessary to make many of the plates here merely supplementary to the previous publication, and to refer readers to that earlier volume for the larger mass of material, especially on pottery. This is a disadvantage, the more so as most of the supporters of the Exploration Fund have not yet seen that earlier volume, which was published separately. To those, however, who wish to follow out the subject, that account is essential; and I must often

refer to it as a necessary basis. Some day a great work embodying all that is known of the pre-dynastic ages, and placing all the changes of peoples and of fashions in their true order, must be brought out; but the present account is only a first stage towards that final work, giving for the first time the methods of systematizing and of historical sequence in a complete and easily worked form.

Beside the prehistoric subjects this year's work has also included much on the dark ages of the VIth to the XIth Dynasties, and the XIIIth to the XVIIth Dynasties, through which we can now see the continuity of the styles of vases, both of stone and of pottery. Much of the XIIth Dynasty, an entirely new class of tombs of foreigners just after that, and a few important pieces of Roman age, were also brought to light.

The ground examined lay between Dendereh, the site of the year before, and Abydos, the site of the following year. At first our party was settled at Abadiyeh, on the edge of the desert, about a dozen miles west of Dendereh. From that centre all the desert to about three miles east was exhausted. All the ground between that and our next settlement at Hu was also cleared; and the desert for two miles west of Hu. It is from this latter site that the name of Diospolis Parva is adopted for this volume.

Our working party consisted of Mr. MacIver and Mr. Mace, as in the year before, who each took a part of the excavations; Miss Lawes gave attention to drawing the pottery, &c.; and Miss Orme, with my wife, drew the marks on pottery and the slates, and shared in the heavy work of numbering skeletons and pottery and the general orderliness of the ever-growing collections.

2. Before entering on the account of the present work it may be useful to some readers to have an outline of the discoveries of the early times that have been made in the last few years.

In 1893-4 I went to Koptos, to search for remains of the dynastic race, which presumably had entered Egypt at that point from the Red Sea. In the lowest part of the temple foundations we found parts of three colossal figures of the local god Min, each with surface carvings of animals, &c. They obviously belonged to a far earlier art than anything known in Egypt, and all later discoveries confirm their being placed as the earliest works of the dynastic race from the Red Sea, long before the establishment of the Dynasties. One figure is at Cairo, and two are in the Ashmolean Museum at Oxford. Beside these there were found pieces of what we now know to be early prehistoric pottery, showing that Koptos was a site dating from the earliest continuous civilization; and also examples of early modelling in pottery. All of this was published in *Koptos*.

In 1894-5 I went to a wide site opposite to Koptos, between Naqada and Ballas. There we opened nearly 3000 graves, which belonged to a civilization different from that of the historic Egyptians. Our party anxiously debated day by day what might be their period; and the limitations of our knowledge about the types of Old Kingdom vases led to our placing some tombs at Ballas to the Old Kingdom, which we now know to be earlier. This led in turn to our dating the great mass of

new remains to the VIIth to Xth Dynasties. This conclusion was the only legitimate one from the facts as then known; but it is not the first time that caution has led to too late a period being assigned to remains. I believe I have never erred in over-estimating a date. As we saw that these remains belonged to a different race to the ordinary Egyptian, quite new to us, we provisionally termed them the New Race; not as referring to their intrinsic age, but much as New Holland was named, although in itself a far older land than Holland. The full account of all this civilization was given in the volume *Naqada and Ballas*.

In 1895-6, M. de Morgan examined some cemeteries of the same age, and published his results in a volume in which he assigned them all to the prehistoric time, together with much material which is certainly of well-known dynastic ages. The total absence of any archaeological evidences or proofs of age in this work, rendered it but a happy guess, without any solid argument. The evidence still remained against such an early dating.

In 1896-7, M. de Morgan found a very early king's tomb, since identified as that of Mena; and the presence of objects of the latest "New Race" style in it was the first real evidence of their truly pre-dynastic date.

In 1897-8, the final proof that the "New Race" remains were pre-dynastic was reached at Denderah, where I worked through a cemetery ranging from the VIth to the XIth dynasty, and so finally ejected the New Race remains from the only dynastic period they could have occupied, thus by exclusion proving their prehistoric age.

Lastly, in 1898-9, we have found several more cemeteries of this prehistoric age at Abadiyeh and Hu. Already in *Naqada* we had made a *corpus* of over 700 forms of pottery of that age, and by using those plates we were able to accurately record every piece of pottery that we found; and the great mass

of precise information thus obtained, together with the records of the Naqada tombs, has made it possible to sort the various changes into their original order, and so reconstruct a consecutive account of the whole of the pre-historic age.

In the preparation of this volume many hands have helped. Mr. Mace has written the account of the cemeteries which he worked. Miss Orme and my wife have drawn nearly all

the pottery marks and arranged the plates, besides continual work in registering and attending to pottery. Miss Lawes drew most of the pottery on the spot, and has since inked in the plates; besides also copying the Ptolemaic inscriptions. The bulk of the plates are my own drawings and photographs. The long map of the desert was sketched in by Mr. MacIver, Mr. Mace, and myself; and the fort plan made by my wife and myself.

CHAPTER I.

THE SEQUENCE OF PREHISTORIC PERIODS.

3. As it will be necessary in the account of these cemeteries to continually refer to the relative ages of the tombs, it will be better to begin with a discussion of the method by which the prehistoric age of Egypt has been subdivided and reduced to a defined order.

Hitherto it has been taken for granted that when no exact age could be stated for a particular civilization it must fall into a general limbo of "prehistoric times"; and the utmost that could be done was to name some periods from the places where they were best represented—such as Chellian, Mousterian, Hallstattian, and to generally say that one such period was before another. Such a system is cumbrous, and gives no scope for exact definition.

But if we can use any definite scale of sequence, where the scale of absolute time is unknown, we can at once deal with a period as simply and clearly as if the scale of years was provided. Such a scale of sequence we have in the numbers of the burials; and if we can only succeed in writing down the graves in their original order of time, we can then be as definite in fixing their contents in a scale of graves as we would in a scale of years.

The problem then is, if we have the contents of hundreds of graves accurately recorded, how can we sort those out into their original order, and so construct a scale?

First, we need to be able to write out the record of the contents of a grave in such a way that it can be rapidly compared with every other grave. To draw figures of all the objects would be impossible, because they would need to be large enough to show small variations, and it

would be impossible to compare hundreds of such together and observe their differences. It is necessary then to begin by forming a *corpus* of all the forms, numbered in order, and then to denote each form by its number.

To deal simultaneously with the records of some hundreds of graves, it is needful to state them as compactly as possible. This was done by writing out the numbers, which express the forms of pottery that were found, on a separate slip of card for each tomb. The slips were $\frac{1}{4}$ inch wide and 7 inches long. All the slips were ruled in 9 columns, one for each kind of pottery. Every form of pottery found in a given tomb was then expressed by writing the number of that form in the column of that kind of pottery. Thus the whole of the pottery found in a given tomb was shown by a row of numbers which could be rapidly compared with the numbers of any other tomb record. The means were thus provided for exact definition and rapid comparison.

Having the material in suitable form we can proceed to arrange it. The general principles of arrangement I have stated in a paper in the *Anthropological Journal* (xxix. 295, 1900); here it will be more to the point to state the actual stages and details. The pottery alone is dealt with for arranging the graves, as it is very abundant and varied: and the other objects—stone vases, slate palettes, flints, &c.—when arranged according to the results of the study of the pottery serve as checks on the correctness of those results.

The general result of the classification of the tombs and their contained pottery may be seen

on pl. ii. ; and a brief view of this, to begin with, will help in explaining the processes by which such a result is reached. Here a series of seven stages is chosen to show the manner in which each period is linked to those which are before and after it. Of course more or fewer stages might have been illustrated here ; but these suffice to show how any period is linked to others, and to give a general idea of the varying styles of the periods. It would be clearly impossible to transpose any two of these groups, of the forms which are found together, without disconnecting them with those before and after. It is needful therefore to have a much finer gradation than seven stages to express the relative ages of varieties ; and practically fifty stages were adopted to cover all this period. As some earlier periods may yet be found, the scale begins at 30 ; and running to 80, it leaves enough numbers before 100 to join up to the historic times in future. Thus the actual numbers assigned are purely arbitrary ; but the order of the stages they represent is certain, and each number represents an equal quantity of burials. Now we turn to the series of steps whereby a card catalogue of grave contents was arranged in nearly the original order or sequence of the graves.

4. 1st step. The most clear series of derived forms is that of the wavy handled vases, some of which are given as the first figures in the five lower stages of pl. ii. Beginning almost globular, with pronounced ledge-handles, waved, (as in stage 35 to 42), they next become more upright, then narrower with degraded handles, then the handle becomes a mere wavy line, and lastly an upright cylinder with an arched pattern or a mere cord line around it. Some of the new varieties, which also show this, are given on pl. xv. ; and the full series of changes in *Nagada* xxxi., xxxii. The order of the changes is also shown by the contents ; at first full of a strongly aromatic ointment, later with a layer of clay over it, next with mainly clay only scented

with ointment, lastly filled with merely solid clay, as in the cylinder jars. The degradation of contents to a worthless substitute proves from which end of the scale the changes proceed. Here we have then a good series with which to begin a classification. To some small extent these varieties were overlapping in time, as we find cognate forms in one grave. How then are the groups which contain one type of wavy handle [W] to be subdivided? Side by side with this W pottery there is a class which since 1896 we have seen to be later than the rest, as it links on to the forms of historic age ; it is lettered L, and new varieties are shown on pls. xviii., xix. : for the series see *Nagada* xxxix. to xli. In any given group of W we can then sort out the slips, placing firstly those which contain L types that occur before, and lastly those with fresh types of L pottery. Thus the large groups are subdivided.

2nd step. Having the slips thus coarsely sorted into a few groups, by W and L, we can next sort each group by the types of Black-topped pottery [B], Polished-red pottery [P], and Rough-faced pottery [R] (see frontispiece and pls. xiii., xvii.), according as the slips contain types occurring before or not. This rough placing can be further improved by bringing together as close as may be the earliest and latest examples of any type ; as it is clear that any disturbance of the original order will tend to scatter the types wider, therefore the shortest range possible for each type is the most probable truth.

3rd step. Having then all the slips which contain W sorted into approximately their original order, by the distribution of the other kinds of pottery which occur with them, we see that all the L pottery falls within the range of W. It is practicable, therefore, to bring into the series all the slips with L, though without W. These are incorporated in the series by looking for the first and last example of every type of pottery occurring on a slip, and then placing it

so that it shall be after all the first examples and before any of the last examples. If it is contradictory, as the last example of some kind of pottery was passed before the first example of some other kind is reached, then either the order previously arranged must be altered, or else we must acknowledge that the new slip contains the earliest or latest example of one of its types. In this and all the later stages only graves with at least five different types of pottery were classified, as poorer instances do not give enough ground for study.

5. 4th step. So far we have only arranged the material which falls within the range of a clear series of derivation in the W types; but we now have a very different problem. How can we project our stages backward beyond the range of a connected series of forms? There is much material, hundreds of slips, which do not fall into the period of W pottery, and we need to classify and connect it to the beginning of the W period. First we arrange the slips that are without W, in the order of the number of types of B, P, R, found with W. Thus we have graves with

0 1 2 3 4 5 6 and more
types in common with those of the W period. And we find that looking to the pottery with white cross lines (C) (see Front.) these successive classes of slips contain on the average

$\frac{1}{4}$ $\frac{1}{16}$ $\frac{1}{25}$ 0 0 0 0
of the C pottery. Hence it is clear that the C pottery is at the beginning, and separated by some interval from the W period.

5th step. Make a list of all types of B, P, R pottery found with C, as these will be the earliest types.

6th step. Next we can try the above classes of graves which contain different numbers of types in common with W, and see how many types they contain in common with C.

Graves with

0 1 2 3 4 5 and more
in common with W, have also on an average

2.0 1.2 .67 .25 .1 .1

in common with C.

This regular disappearance of types associated with C, as types associated with W increase, gives good ground for adopting these groups as a true classification of the period before W.

7th step. Thus classifying the period before W, we can classify the C end of this scale according to the proportion of B, P, R types found with C which they contain; and the W end of the interval by the proportion of types found also with the W period.

8th step. Finally arrange the C period by grouping the instances of each type of C as near together as may be; and group similar types together so far as allowed by other kinds of pottery.

9th step. The decorated pottery [D] (see pls. xv., xvi., and *Naqada* pls. xxxiii.—xxxv.) has so far received no attention; but as the graves containing it have at this stage been already roughly sorted by the statistics of the other pottery found with it, we can now use it as a means of further sorting. It is valuable material for this purpose, as the detail of the decoration is more likely to vary than the mere form which we have to judge by in other classes. Each type of D was therefore examined, and its occurrences concentrated together, as far as was possible without upsetting the W series, or spreading out the range of other kinds of pottery.

6. 10th step. Having now about 700 slips of graves sorted into their original order by these various considerations, we now make a first division into fifty equal stages, numbered 30 to 80, termed *sequence dates* or s.d., and then make a list of all the types of pottery, stating the sequence date of every example that occurs in these graves.

11th step. So far only graves containing pottery of well-marked characters, as C, W, L, &c., have been dealt with. Now on the basis of the list made in the last step we incorporate

all the other graves which contain enough pottery to define their position. So far as they may modify our views of the s.d.'s of the types, the list of s.d.'s is amended.

12th step. All of the material being now built together, and in approximate order, the further processes are for more exact arrangement in detail. All the slips containing C pottery were placed together at the beginning; but there is also a large number of slips which come before D and W, but which do not contain C pottery. Should these really be interspersed among the graves which contain C, and is it a mere accident that these do not contain C? The only test for this is the frequency of new types of other classes of pottery. If the post-C graves are really of the period of C graves we should find fewer new types beginning in post-C, as they would have been already anticipated in C. Or if C and post-C graves are already in their true order, the frequency of new types should be the same throughout. Taking the new forms we find that on each slip on an average there are of new types

	B	P	F	D	R
in C period	1·3	·59	·07	·07	·14
in post-C	·26	·19	·05	·03	·28

Hence many post-C slips should go into C, as the new types have already been largely anticipated in C. There are some other considerations, rather too complex and detailed to state fully here, from the actual number of pots of new types, the starting point of R pottery, &c. Finally, instead of 44 graves being of C and 148 of post-C, 47 were transferred to the C period, leaving 91 in C and 104 in post-C; some of these were however returned back again on studying the range of each type. The motives of arrangement have therefore come to a balance, and it is unlikely that there is any serious error of sequence.

13th step. The previous arrangement is confirmed if we ignore the C pottery entirely,

and date all its slips solely by the other pottery which they contain.

7. 14th step. After this re-arrangement of the whole period before W, the sequence dates of the types of pottery were all retabulated.

15th step. Having exhausted the statistical methods of arrangement, and obtained all we can from them, we now turn to the treatment by the extent of range of each type of pottery. As already mentioned, the shortest range of any type is probably the nearest to the truth. Hence we look over the list of s.d.'s of each type, in the list of types; and wherever the first or last example is far out from the rest, the slip containing it is examined to see whether it can be brought closer to the others. We may graphically imagine this sorting to be represented by an elastic thread for each type, attached to all the slips containing that type, and then the resultant position of all the slips under the tension of all the threads will be the probable truth; the weakness of each thread being in proportion to the true extent of diffusion of its type. Every instance of wide dispersion is also examined, and concentrated as much as is possible without scattering another type. Thus the position of many slips has to be a compromise between bringing one type early or taking another late; and the likelihood of a type being extended is judged by the range of the other types most alike it. Often several types hang together, and must all be transferred if one is moved, and then the ranges of twenty or thirty types have all to be reviewed at once. Most of these changes are however but small, not extending beyond one or two stages of the whole range of fifty.

16th step. The material thus mechanically arranged in its main outlines by various tests, is then subject to an artistic and subjective review, as to credibility of style and development, and similarity of forms in different classes of pottery; any likely alterations which do not violate the statistical probabilities are then

made; but this is only a finishing matter, and is not allowed to weigh against the more solid facts.

17th step. The whole series (900 slips) is then re-divided into 50 equal groups; and the list of the s.d.'s of each type is re-formed accordingly.

18th step. A list of all the graves that have been entered on slips, and of all others not yet examined, is then formed, with the sequence date of each grave stated in accordance with the ranges of its pottery types. This list serves for the subsequent dating of all the other objects found in the graves.

At the end of the period the question of whether the cylinder jars of pottery were all descended from the wavy-handled vases, or were copied from the earlier stone vases, was also tested statistically by the number of types of other pottery; but the results showed that they must be connected with the wavy-handled pottery jars. A class of the rudest shallow graves, with only black topped pots, was classed as 30, as they were clearly before the C pottery beginning at 31.

It should be observed that these various steps of arrangement cannot be taken in a different order; but that each has its proper place in relation to other steps.

The resulting sequence dates for each class of objects will be afterward discussed in dealing with the stone vases, flints, metals, &c. Here we give the sequence dates for all the varieties of pottery known, both those in the *corpus* of forms in *Nagada*, and those new forms published here in the plates xiii.—xix. These tables are the essential basis for all further study of the prehistoric, and from them the relative age of any newly-discovered tombs containing pottery can be at once read off. Examples of this use for dating are given at the end of the tables.

The range of each type is stated thus 37—45; if a stray example is far from the rest, and may be accidental, it is separately stated as

37—45, 62; meaning that most instances lie between 37 and 45, but one is found as late as 62, which should not be relied on: where only commas appear between numbers, as 37, 45, 62, it means that only those three instances are known. If numbers are in loops as (37—45) it means that only one instance is known, in a grave with that uncertainty of age.

8. BLACK TOPPED POTTERY [B] pl. xiii.; *Nagada* xviii.—xxi.

Type.	S.D.	Type.	S.D.	Type.	S.D.
1a	31—70	22h	31—48	40c	38
b	35—50	23a	31—38	41	40—45
c	32, 58	b	34—46	42a	37, 57, 70
d	32, 38	c	(60—61)	b	31—50, 63
e	35, 52, 70	24a	57, 64	43	51, 59
2	(38—61)	b	(44—50)	44a	37—46
3a	35, 46	c	39	b	40—44
b	(31—55)	25a	31—55	45	(52—68)
4	(42—70)	b	30—38, 59	46	41—51
5	48, 62	c	31—41	47	32—80
6	34—46	d	34—50	49	36—55
8	56	e	31—55	50	48—66
10	37	f	30—50	51	36, 47
11a	35—51, 61	g	31—56	53a	38—66
b	31—56	h	36—50	b	40—75
c	37—40	26a	31—50, 69	d	62, 65
d	31—44	b	31—51	54a	33—64
e	36—63	c	31—56	b	35, 36
f	31—63	27a	32—48	55	36—39
12	57	b	33—43, 63	56	41, 48
13a	60	c	33—45, 62	57a	31—62
b	59	d	31—55	b	31—61, 75
15	31—61	e	32—41	58a	35—68
17a	31—33	f	34—46	b	35—43
b	37	g	35, 36	58c	35—55
18a	36—43	29a	30—34	61	34, 54
b	33—62	b	34, 41, 58	62a	37—57
c	34—56	d	33—35	b	34—59
d	31—63	33	38	63a	36, 48
e	76	35a	32—43	b	35—39
19a	30—47	b	38—46	64a	41—43
b	33—46	c	36—51, 70	b	37
21a	33—47, 69	d	34—43	c	36, 38
b	30—47, 62	36	35—46	d	34, 37
c	31—68	37a	36—51	65	72
d	35—37	b	63?	66a	34—63
22a	31—52	38a	43, 66	b	36, 44
b	30—37	b	33, 34	67	42, 53
c	32—44	c	31—74	68a	37—61
d	31—38	d	37	b	31—61
e	37, 50	39a	44—61	69a	43, 45
f	30—36	b	39, 63	b	43, 44
g	31—34	c	63, 64	71b	38, 43

72a	31-46, 63	76b	43	84	30
b	35-51	77a	34-41	85	30
c	33-47	b	34, 36	86a	(32-48)
74a	31-61	78a	34-51	b	(40-43)
b	33-57, 76	b	33-47, 72	87	36
c	33-55, 73	c	38, 43	92a	37
d	32	79a	31-48	b	31, 37
75a	40-57	b	32-46	93a	47
b	31-57	c	35	b	44-63
c	43	81a	34, 37	94a	38
d	43	82	40	b	37
76a	35-46	83a	45	c	36

9. POLISHED RED POTTERY [P] pl. xiii.;
Naqada xxii.—xxiv.

1a	32-54, 68	30	(33-47)	56a	31-56
b	31, 37, 61	31a	43, 80	b	31-58
2a	31-52, 63	b	36	57a	39-73
b	32-41	33	35	b	48-74
4	34-38, 61	34a	50	58a	40-72
5a	32, 35	b	41, 46	b	32-55
b	32	c	40-58	59	38-58
c	46	d	(33-80)	60	37-62
6	36	35	41	61a	35
7	32, 34	36a	42	62a	34
8b	37, 43	b	42, 68	g	71
9	40, 42	c	38	63	31-44
11a	31-63, 80	37	36, 39	64	42
b	35-71	38	49-66	b	(59-66)
c	35, 40, 63	40a	39-70	65	33-37
d	31-65	b	34-70	66	34, 41
13a	32, 33	c	40-65	67	(58-65)
b	35	d	57, 64	68a	31, 39
14	39-63	e	42-70	b	31, 34
15a	32-47	41a	42, 53	69a	37
b	32-39	b	42, 44	b	33, 34
16	33-58, 72	c	35, 43	70	38-47
17	30-42	42	48-65	72a	(52-68)
18	39-43	43	38-55	b	37
19a	38, 46	44	70	73	43, 50
21a	35, 48	45a	42-59	74	43-62
22	33-80	b	43-56	75a	38-71
23a	38-73	c	38	76	43, 45
b	41-72	46a	63-76	77	38, 75
c	35-68, 80	b	38, 72, 75	78a	68
d	66	c	63-75	c	68
24a	32	d	71	81a	57-69
b	32	e	69, 75	b	41-72
25	33	f	76	82a	43-57
26a	34	47a	34-61	b	58-79
b	32-50	b	44-63	c	43-59
27	45	51	47	84a	50, 63, 72
28a	35, 39, 72	53	35, 37	85a	53, 59
b	43	54	35-50	b	46
29	(37-39)	55	(38-43)	86a	63, 71

86b	75	93c	52-68	95b	46-72
87a	40, 50	d	40-70	96a	(35-53)
b	50	94a	50, 51	b	(31-46)
88	64, 71	b	46	97	63, 64
91	69, 72	c	43, 44	98a	50-65
93a	48-68	95a	37-71	b	57-64
b	37-67				

10. FANCY FORMS [F] pl. xiv.; *Naqada*
xxv.—xxvii.

11a	31-54	43b	34	70a	36, 37
b	36, 38	44	50 P	72a	36
12	36-44	51a	39, 47	b	34
14	35-53	b	38	c	37
15	34-56	52	38	80a	47-61
19a	39	58a	40-50	b	37, 53
b	35	b	43	c	(50-69)
24b	45	e	61	81a	48
25	35	62a	36	b	34
27	37, 38, 56	b	36	c	39
30	(36-63)	64	37	83	42
31a	52	65	55	85a	31-73
b	53, 57	66	34	b	45
c	40-61	67	61	91	(33-45)
d	45-56	68a	38	92	35
34a	42, 43	b	40	96a	38
40	51	c	33	b	34
41	40	d	34, 58	98	51
42b	50	69a	50		

11. WHITE CROSS-LINED POTTERY [C] pl.
xiv.; *Naqada* xxviii., xxix.

1	31	34	31	74	33
2	32	36	31	75a	32
6	31	38	31	b	31
7	31	40	32	76	31, 32
8	31	42	32	77	32
11	31	43a	34	78	31
12	31	44	33	79a	32
13	34	46	31	80	32
14	32, 33	48	32	81	33
16	31	52	32	84	33
18	31, 32	54	32	85a	32
21	33	56	32	b	31
22	31	60	32	c	32
26	34	61	31	d	31
27	32	63	32	86	32
28	34	64	32	91	32
30	34	65	32, 33	93a	32
31a	34	67	33	b	34
b	34	68	33	95	32
c	34	69	33	96a	33
32	34				

12. BLACK INCISED POTTERY [N] pl. xiv. ;
Naqada xxx.

2	51	20	38	30	54
6	42-47	22	42-63	31	54
10	57	24	46	32	47
12	38	26	46	55	33
15	35	28	50, 52	67	68

13. WAVY-HANDLED POTTERY [W] pl. xv. ;
Naqada xxxi., xxxii.

1	40	25	58-62, 73	55a	72-78
2a	52, 62	31	65	b	72-78
b	61, 62	37	64	60	70-72
3a	42, 53	41	63, 64	61	73-79
b	42, 43	42	62-72	62a	75-79
4	46-61	43	59-66	b	77, 78
6	46, 53	47	66-71	71a	78-80
8	52, 68	51a	71-75	80	79, 80
14	46-58	b	71-75	85	78, 80
19	52-66	54	72	90	80
23	61-63				

14. DECORATED POTTERY [D] pls. xv., xvi. ;
Naqada xxxiii.—xxxvi.

1	63	19	50	43	40-63
2a	52	20a	62-71	45	46
3a	62	c	75	47	52, 53
4a	49	21	75	48	45
b	49, 50	24	61-63	a	63
c	52, 53	b	72	50	46-53
e	52	25a	69	51a	48, 49
5a	42-63	26a	74	52	42
b	44, 45	27	69-75	53a	42
6	63	29a	37	b	60
7a	40, 44	31a	47, 48	c	63
b	33-63	b	40-45	54	60
c	51	32a	55	55	46, 61
8a	44	b	63	56a	47
b	31, 41, 61	35a	40-52	b	46
c	46-63	b	46-52, 59	57a	46
d	46-48	c	43	b	47
11	44	36a	40, 54	58	62
12	49-53	b	55	59a	56
14	48	c	40	b	46-60
15	31	d	48	c	46
16b	65	37	63	d	46, 47
17a	40-50	40	46, 63	60	49, 59
b	46, 47	41a	51-63	61	43-59
18a	44	b	46	62	47-71
c	56	42	48	63a	48-63

63b	43	72	32	81	32-36
c	36, 41	74a	80	83	37
64	60	75a	65	88a	41
65	63	b	48	b	37
66	69, 75	76	34	c	34
67a	46, 57	78a	52	91c	41
c	44-64	b	66	92	40, 41
68	39-61	79	60	93b	(38-43)
71	46	80	52		

15. ROUGH-FACED POTTERY [R] pl. xvii. ;
Naqada xxxviii., xxxvii.

1a	50, 80	32a	57	68b	(44-57)
b	37-72	b	54, 62	69a	53-66
c	38-63	c	54	b	36-71
d	63	33	43, 66	c	36-68
e	51-63	34a	44-79	d	43, 44, 63
2	(37-74)	b	43-64	71a	55, 63
3a	33-64	c	43-73	72	37
b	41	36	53-77	c	(36-63)
c	42-63	38	37-75	74	50-78
4a	58	39	36, 39	75	43-70
5c	66	40e	63	76	47-78
6	41, 45	41	38	77	66
10a	40-52, 80	42c	53	78	50, 71
b	39-60	43	52, 58	79	36-72
11	45, 57	44	60	80	41-73
e	51, 63	45a	52-63	81	38-67
12b	34, 62	46	79	81a	(59-66)
c	35	47	38	b	44, 56
14	44	50	36-67	c	44
15	38-47	51	33, 44	82a	38, 41
16a	51	53	68-80	b	38-65
b	54-78	55a	34-74	c	36-44
17	43-70	b	51-73	83a	43-78
18	73, 80	57a	34-75	b	33
20	65	b	57-68	84	52-76
21a	70	c	43-72	85	47, 61
b	34, 65	d	44	86	72, 76
d	36-58	58	46	88	59, 61
22a	35-80	59	42	89	41, 42
b	44-79	61a	56	90	63, 76
c	75	b	60, 61	91a	41-65
23a	39-73	c	63	b	36-39
b	37-75	62	42-77	c	36, 39, 62
c	36-80	63	50-80	92	44-61
24	42-80	65a	49-68	93a	37-46
26a	55-80	b	47-65	b	39
b	80	c	60-73	94	49, 53
27	53, 72, 78	d	65-72	95a	51
28	41, 66-80	66	42-77	96	37, 72, 74
c	59	67	39-74	97	63
30a	(36-56)	68a	40-53	98	44

16. LATE POTTERY [L] pls. xviii., xix.;
Naqada xxxix.—xli.

1	68	25a	64—75	53b	55—74
2a	73, 76	b	70	c	54—80
b	73—78	26a	46—72	d	(55—74), 78
c	69	b	59	e	70
3	78	28a	64, 73	f	73, 78
4	60, 68	b	73	54a	72
6a	73	29a	73	b	80
b	60, 63, 80	30a	68—78	55b	48—74
c	77	b	58—76	56a	73
7a	53—58, 78	31	72, 74	b	71—72
b	39—76	33a	73—79	c	74
c	55—76	c	71, 78	57a	80
d	60—69	34a	71—80	b	68
8	65—78	b	65—80	58a	68—78
9a	43, 70?	c	71	b	72
10	63, 69, 80	35a	79	59a	75, 78
12a	50—73	36a	58—80	60	60—78
b	47—68	b	65—80	62	77
c	47—79	c	65—78	64	72
d	68—78	38a	70—80	66	72
14	54—76	b	74	67	68
16a	43—78	39	43	69	78
b	58—78	40a	57—76	71	71
c	71—78	42a	58, 75	72	73
17a	59—78	b	70—78	74	70
b	56—78	d	69	76	79
c	45—78	43	60, 69	78a	73
d	67, 68	44a	60—78	c	73
e	56—78	b	60—78	82	70
f	53, 80	46	60, 68	84b	72, 76
18	68—74	47a	76	85	71, 74
19a	70, 78	b	56	86a	72, 76
b	54—76	50a	67—79	b	80
c	35—80	b	78	88	76
20	55—58	51	70, 73	94	70
21	56, 63	52	60, 72	cist	65
24	73	53a	48—74		

Those readers who are actually working on the subject are recommended to insert these sequence dates on the plates of the pottery.

17. Now, to give some instances of the use of such tables, we will take the fullest and most varied groups found in tombs at Abydos, after the tables were made; and show how the date of a tomb is quickly delimited from the sequence dates of the various kinds of pottery found in it, and how in some cases we obtain fresh information about the range of types.

TOMB ϕ 22.		ϕ 55.	
S.D.		S.D.	
B 22b	30—37	B 22f	30—36
B 25f	30—50	P 1a	32—68
P 11a	31—63	P 17	30—42
P 11b	35—71	P 68b	31—34
Limits	35—37	Limits	32—34

Here in the first tomb we see from the ranges of types that it cannot be before 35, by P 11b; nor after 37, by B 22b. The latest date of beginning of a type, and the earliest date of ending of a type, are the limits of uncertainty as to the age of the tomb. Similarly the second tomb is between 32 and 34.

TOMB χ 10.		χ 12.	
W 51b	71—75	P 57a	39—62 (—73)
W 55	72—78	W 55	72—78
R 22a	35—80	W 61	73—79
R 65d	65(—72)	R 23c	36—80
L 30	68—78	R 65c	60—72 (—73)
Age	72	L 30	68—78
		L 36b	65—80
		Age	73

Here in the first tomb there was a contradiction, according to the ranges first used; W 55 does not begin till 72, while the only examples known of R 65d were at 65; hence it was needful to suppose that R 65d continued in use down to 72, and the range is corrected accordingly. In the second tomb we find likewise that P 57a, formerly credited as 39—62, must extend to 73, which is very likely, as the similar form P 57b goes on to 74; also R 65c must run to 73 instead of 72.

Other examples of tombs are,—

χ 20.		χ 30.	
W 55	72—78	B 38a	43—66
R 26	55—80	W 42	62—72
L 17e	51—78	R 23c	36—80
L 36a	58—80	R 65a	49—68
L 53a	48—74	R 80	41—72
	72—74	L 53c	54—80
			62—66

x 59.		x 79.	
D 24	61—72	P 23c	35—68
L 12d	68—78	R 23c	36—80
L 30	68—78	R 69c	36—68
L 53c	54—80	L 12d	68—78
	68—72	L 30	68—78
		L 43a	60—69
			68

In the last we see how closely the age is fixed by two types not beginning till 68, and two disappearing in 68.

Of course, where only a few pots of wide-spread types occur, it is naturally impossible on any system to define the age closely; but where there are several well-fixed types it is generally possible to limit the age to three or four grades, or within a twelfth or fifteenth of the whole period, and often we find it limited to a single grade.

18. Now, were these various sequence dates, here assigned to the pottery types, a mere fantasy (as doubtless many people will conclude who do not take the trouble to understand them), it is clear that we should find it impossible to use the dates to closely fix the age of fresh tombs, as there would be ceaseless contradictions in any baseless system. Of course, here and there it is only reasonable that we should find that the full range of a type has not been yet reached, especially that types ran on in a few instances later than their general use; but such occasional extensions can generally be justified by the range of a fellow-form already determined.

When, moreover, we find that on dating the tombs by this system we obtain a consistent and regularly developing history of the stone vases, slates, tools, &c., we have the strongest confirmation of the solidity of the general results. I should be far from supposing that small

changes may not be needed, or small errors detected by more study, but the main outlines of the prehistoric age are now decisively fixed.

It would be useless to enter here on tracing the details of the successive changes of the various forms of the pottery, without having a series of plates to show the transformations. Some general remarks may however be made.

The date of the introduction of a form is far more important than that of its last appearance, as all forms went on being copied mechanically, often long after the original taste for them was past. Hence the date of first appearances show the point of greatest activity in any style; and the date of the mid-most of the first appearances in each class is the point of its greatest importance. Tested thus the most flourishing period of each of the classes is as follows:—

C	32 sequence date
B	34—5
P	39
R	43
D	46—7
N	46—7
L	68—9

It is found in several instances that the same form is contemporary in different classes; for example P 38 begins at 49 and is commonest at 53, D 47 is of 52 and 53, and L 53a begins at 48 and is commonest at 58, the form thus occurring together in three classes. The presence of brims or lips is not common in early forms, mostly occurring between 50 and 60. The taste for oval forms begins with the open dishes, F 11 to 24, which all start in the thirties, and none extend beyond 56; whereas the oval vases, F 30, 31, do not begin at all till 40, and are commonest in the fifties. Thus the pottery agrees with the stone-work, as the oval stone vases, S 71—75, begin at 38 and are also commonest from 50 to 60.

CHAPTER II.

THE POTTERY.

19. Before reading this chapter it will be best to turn to the coloured key (Frontispiece), which shows the various classes of pottery and the principal forms known of each. Further, on pl. ii., is shown the manner in which certain types belong to one period, and are connected with both the previous and the following periods. And on pls. xiii.—xix. are shown all the new types found at Abadiyeh and Hu. Those who want the full series of types already known must refer to *Naqada*, pls. xviii.—xli.

BLACK TOPPED POTTERY. Class B.

The oldest pottery yet known is the red burnished pottery with black tops, pls. front., ii.; *Naqada* xviii.—xxi. This, like all the prehistoric pottery, was entirely made by hand, without the wheel. The material is a fine grained sandy and micaceous clay, apparently Nile mud tempered with as much of the material of a Nile sand-bank as it will carry. It is soft and friable, but the outside is smoothed with a coating of haematite (or burnt ochre), highly burnished up and down. All these pots were baked mouth down in a fire, the ashes of which formed a bed a couple of inches deep, and so deoxidized the haematite around the mouth of the jar. In good examples the haematite has not only been reduced to black magnetic oxide, but the black has the highest polish, as seen on fine Greek vases. This is probably due to the formation of carbonyl gas in the smothered fire; this gas acts as a solvent of magnetic oxide, and hence allows it to assume a new surface, like the glassy surface of some marbles subjected to solution in water.

The oldest types of this pottery are apparently the very simple cup forms (top line, pl. ii.) which are found only one in a grave, of the rudest and earliest age of the prehistoric. These graves were in a small cemetery on a little hill near Abadiyeh; shallow saucer-shaped pits, just large enough to hold a contracted body, and about a foot or twenty inches deep. The bodies were closely doubled up, generally with head to the south, and lying indifferently on either side (see pl. v., fig. 1.) They were wrapped in goat skins, never in woven stuff; but copper was known, as a pin was found. Slate palettes rarely occur, and only rhombic in form. Every detail points to these being the earliest graves known; and they resemble in form and depth the later burials of Libyans who came in after the XIIth Dynasty. They are therefore probably of the Libyan type first brought in, before the development of a fresh civilization in the new and fertile land of the Nile.

It seems probable that in these earliest types we see the origin of every form adopted for this black topped pottery; these cylindrical and open cup forms passed into the various dishes and narrow-necked jars which appear throughout the earlier half of the prehistoric ages.

20. POLISHED RED POTTERY. Class P.

Even in the earliest period, the graves of which have been above described, the advance had been made of supporting pottery above the ashes of the fire, and so attaining a uniform red all over. Probably the black top was felt to be a defect, though certainly later on it was

treated as an ornament, just as many defects of manufacture become so familiar that they are afterwards deliberately imitated. The oldest form of polished red is the small open pan, P 17, at the end of the top row in pl. ii. (see *Nagada* xxii.—xxiv.). But the plain red quickly came into use, a third of the known types being brought in between 32 and 36. The forms differ, however, from those of the black topped. The lip is generally turned out by the black topped, B, but turned in by the polished red, P. The cylinder is a main stock of B types, while the spheroidal jar with a brim is common in P types. The narrow-necked bottle is rare in B, but usual in P.

The red polished lasted on later than the black topped class; the majority of the B types is over by 50, while the same majority of P types is not over till 60. The finest examples of this class are the noble spheroidal jars, P 40, which often have a beautiful variety of tints, varying from purple red to dark orange according to the air in the furnace; from these tints they commonly have the name of "plum jars."

21. CROSS LINED POTTERY. Class C.

Immediately after the start of the polished red pottery we find that ware ornamented with white cross lines in various patterns, see pls. Front., xiv.; *Nagada* xxviii., xxix. This class only lasted in Egypt for a short time, from 31 to 34 sequence date, or but an eighth of the whole history of the polished red. It is, however, apparently connected with the Kabyle hand-made pottery, of red with white lines, which is of the same colours and similar in patterns. It seems therefore as if this had been brought in by the Libyan settlers, and then lost to use in the new civilization which grew in Egypt. The patterns are copied from basket work; the earlier are the bowls with centre circles, and tall jars with chevron lines; the latest are the bowls with blank centres. Animals are often represented, usually goats;

but boats never appear. In one case a combat between two men is shown, the oldest human figures known (F. P. coll.).

22. FANCY FORMS OF POTTERY. Class F.

Many strange forms occur of the black topped or polished red ware, which cannot be classed as ordinary pottery, see pls. Front., ii., xiv.; *Nagada* xxv.—xxvii. The oval dishes, sometimes on feet, the oval jars, double jars, spout jars, square bottles, fishes, birds, imitations of stone vases, &c., are found side by side with regular pottery of the same colour; mostly between 31 and 50, only a third of the types running on later. They belong therefore distinctly to the earlier age of the prehistoric times.

BLACK INCISED POTTERY. Class N.

This ware differs entirely from any other known in Egypt; and is only found singly and in rare instances in prehistoric times, see pls. Front., ii., xiv.; *Nagada* xxx. It is akin to other such ware found in the 1st Dynasty (Abydos), in the IIIrd Dynasty (Dahshur and Denderah), in the XIIth Dynasty (Kahun and Khataneh), in the "pan graves" of Libyans in the XIIIth Dynasty (Hu), and on to the XVIIth or XVIIIth. It is closely like in material and pattern to pottery found at Ciempozuelos near Madrid, at Butmir in Bosnia, and in the lower levels of Hissarlik. As in no period is there any Egyptian pottery which is connected with such a style, we must look therefore to some foreign source for it, such as Libya, Sicily or Italy. The material is always a soft, fat clay, not much baked, thick in early times, thin in the XIIth Dynasty. The pattern always imitates basket work, and is pricked on the pottery; in later times with a toothed comb. The incision is always filled in with a white clay. The forms of the prehistoric time are almost always deep bowls; and sometimes imitations of baskets with lids, as 67, 68, on pl. xiv. In the XIIth Dynasty, elegant narrow necked jugs were made, with loop

handles, distinctly Italian in style. The source of this pottery would be a matter of great interest to discover, as being a centre of the early Mediterranean trade and influence.

23. WAVY HANDLED POTTERY. Class W.

This is one of the most variable classes of pottery; and by its manifest course of degradation it serves as the best clue to the order of the successive periods, see pls. Front., ii., xv.; *Naqada* xxxi., xxxii. The main changes are shown on the left hand side of pl. ii. Beginning in the third row as globular vases, with ledge handles of wavy form, it passes through continuous degradation, until it is assimilated to the cylindrical stone jars with cord line around the neck. The material is hard light drab pottery, well baked, a fat clay without much sand. No paintings are known on this pottery except cordage pattern at about 75. The latest of these cylinder forms appears in the tomb of Mena, and they then dwindle during the Ist Dynasty until they become merely the roughest little tubes. The wavy handle, as on the earlier types, is a characteristic of early Palestine pottery; and a connection can be more readily granted as the mode of surface scraping with a comb is found in both the Ist Dynasty and also on the wavy-handled jars in Judaea. The constant use for these jars was to contain ointment, apparently palm oil; and in later times mud was added, until at last only mud was used.

24. DECORATED POTTERY. Class D.

The material of this is like the wavy-handled and some of the late pottery, but its distinction is in the painting of designs and figures on it in dull red colour. See pls. Front., ii., xv.; *Naqada* xxxiii.—xxxvi. None of the patterns are derived from basket work; but some come from cordage and rush covering (like modern oil flasks) and some patterns from marbling. There is not a single point in common between these patterns and those of the cross-lined pottery, C.

Two types, 8b, 15, begin very early, in

s.D. 31; and the model boats, 81, begin in s.D. 32; then follow the squat vases, 7b, in s.D. 33; the earliest imitation marble, 63c, in s.D. 36; a chequer pattern, 29, in s.D. 37; and squat vases, 68, with cordage pattern in s.D. 39. All of these are, however, very scarce in the thirties, and need not be more than importations, like the black incised pottery; they are not a twelfth of all the types, and are themselves much commoner later on. The main appearance of this decorated pottery is in the forties, when 48 new types come in, followed by 33 in the fifties and sixties, and only four in the seventies. This pottery essentially belongs then to the middle of the prehistoric time. The principal types and their ranges are as follows:—

Cordage pattern	31—63
Marbling	36—63
Spirals, on upright pots	40—52
Spirals, on squat pots	39—64
Aloes (?)	40—54
Boats	40—63
Three handled, with boats	46
Three handled, with ostriches	46—53
Hills	46—56
Splashed	47—71
Wavy parallel lines in short groups	61—75

The boat or ship pattern is the most important, both for its variety and for the light it throws on the commerce of the time. When these drawings were first described and figured (see *Naqada* xxxiv., 40—47, lxvi., lxvii.) there were objections raised to identifying them as boats. But the discovery of much larger and more elaborate paintings on the walls of a tomb at Hierakonpolis (see the Egyptian Research Account volume, *Hierakonpolis*, part ii.), have abundantly proved that we have here the earliest shipping yet known. The number of oars is sometimes as many as sixty; and without supposing this to be an exact drawing, yet it shows that galleys with several dozen rowers were then well known. The prow of the galley has a branch of a tree upright on it, to serve as a

shade for the look-out man; belows hangs the tying-up rope: the stern has sometimes the great steering oars (*Naq.* lxvii. 14, and Hierakonpolis tomb). In the mid-ships are always two cabins, and in the Hierakonpolis drawings a quantity of material is shown stowed on the roofs of them. The hinder cabin always has the ensign of the boat on a tall pole behind it. These ensigns are shown classed according to sequence dates on pl. iv. The earliest are here put to s.d. 36; but the jar which shows both of these is only dated by one other jar, B 21d, which might very possibly be as late as the forties, like the other B 21 types. These seem to be possibly garland ensigns. The hill ensigns, with from two to five hills belong to the forties; and also the hawk on a crescent, which lasted through the Ist on to the VIth Dynasty. The Z sign is unexplained; it occurs among pottery marks, and on a slate palette. The elephant was probably a small one stuffed, like the stuffed crocodiles hung over shop doors in Cairo. The cross lines seem as if they were the arrows of the goddess Neit, as in the Ist Dynasty. The two pairs of horns and other objects are not yet explained. The group of hills, two to five, show that these ensigns were the mark of the port from which the boat came, rather than the emblems of owners. That Mediterranean ships had ensigns in late times is shown by the tale of an ensign of Gades found in the Red Sea, and set up in Alexandria in order to be identified.

The other figures on these decorated jars are difficult to understand. One of the most usual is a tree (*Naq.* xxxiv. 36, 37), which has been termed an aloe by Schweinfurth; it is more like that than like any other plant, and as it is always represented in a tub or pot it seems connected with the present taste for aloes growing in pots, which are common in the cemeteries of Egypt and North Africa. Bushes seem also to be shown, as suggesting a landscape. The frequent figures of men, animals, and trees, above the boats, merely point to the boats being seen

in a creek or harbour with the shore behind them.

The more specialized patterns seem to have only been made during a brief time. The common types of the spiral, the aloe, and the boat, lasted about twenty stages, from 40 to 60; but the large three-handled jars with boats, the large lipped jars, and the long rows of ostriches, each belong to a narrow period. Very probably some types were only made during a year or two, or even for only one single furnace load.

25. ROUGH-FACED POTTERY. Class R.

This class is not very definite, yet it is quite distinct from any of the other classes, and so forms a group by itself. The most usual types are given in Frontispiece; and all the forms in pls. xviii. and *Naqada* xxxvii., xxxviii. The principal use of it was for the great jars of ashes buried in the graves. Sometimes as many as fifty, or even eighty jars, weighing twenty or thirty pounds each, full of ashes or burnt earth, are found in a single grave. These ash jars begin with a narrow neck, R 79, at s.d. 36; but very soon, at s.d. 38, the wide-mouthed conical ash-jar, R 81, came in, and then both forms continue in use till about 70, yet they are seldom if ever found mixed together in one grave. At 68 the ash jars become much narrower with long solid bottoms, L 30, but these are classed in the late pottery, next described. Another frequent type of rough pottery is a small conical jar, beginning with a contracted mouth, R 75 in s.d. 43, widening in R 76 at s.d. 47, and becoming a simple cone R 77 at s.d. 66. These jars are only found one in a grave; they never contain ashes, and are always at one end of the grave. Two other types are common, the little pointed vases, R 65 to 69, which run from s.d. 36 to 74; and the narrow-necked bottles, R 91, 93, which run from s.d. 36 to 65.

26. LATE POTTERY. Class L.

This class is somewhat mixed in materials,

but was set apart when classifying the pottery, as being introduced distinctly later than all the other classes, having ugly and degraded forms, and being linked on to the historical pottery. The general types are in Frontispiece, the fresh forms in pls. xviii., xix., and the main body in *Nagada* xxxix.—xli. The material is generally hard, and in the larger jars pinky on the surface; the smaller cups and bowls are often salmon coloured or light orange-red, thin, and coarsely burnished in parallel lines. The ash-jars, L 30—36, are mostly of soft rough brown pottery.

The rise of this class is much later than any other. Only a tenth of the types are known before s.d. 50, and those are almost all open

bowls: the main production is at s.d. 70, when the other classes have almost died out. The late examples of decorated and wavy handled pottery are practically the same material as the usual late pottery. The close of the late pottery joins into the early historic; the pottery of the Mena tomb being all akin to late types, but yet later in each case than what is here put to s.d. 80. This period between the s.d. 80 and the series well fixed now in the Ist Dynasty tombs of Abydos, is not yet cleared up. Many types lead on from one age to the other, and we may hope that further excavation will thoroughly connect the close of the series of sequence dates with the beginning of the historical time.

CHAPTER III.

THE STONE VASES.

27. Throughout the whole prehistoric age, from immediately after the rude savage burials of s.d. 30, down to the end, stone vases are abundant. Moreover the taste for hard stone was kept up in the historic times; hundreds of stone bowls were buried with each king of the 1st Dynasty, and many are found in tombs of the IIIrd and IVth Dynasties. But in the XIIth Dynasty the softer serpentine and alabaster supplanted the fine diorites and porphyries, and in the XVIIIth Dynasty the art of working hard stones was forgotten for anything but statuary. From the point of view of magnificence and skill in using hard and beautiful stones we must say that the Egyptians gradually rose to their highest level in the later prehistoric and early dynastic times, and that the VIth, XIIth or XVIIIth Dynasties cannot for a moment compare with the archaic grandeurs.

The various types of stone vases are divided in two classes, the hanging vases with ears, and the standing vases; there are no forms that require a ring stand, as in the pottery. Indeed nearly all the hanging types will also stand upright. The types known before are given in *Naqada*, pls. viii. to xvi., where the last four plates are of the later prehistoric and early historic: and the new types of this year are given on pl. ix. The history of the introduction and changes of types is given on pl. iii. Each principal form is drawn with its top at the date where it was first used and a line continues its course down to the date where it disappears. Where the range of a vase is

very short it is marked by a line at the side of the figure. Of course many stone vases are found in graves which are not closely dated by pottery, and so are not entered in this table, as only the well fixed examples can be marked. Indeed it appears as if the pottery vases were looked on as a substitute for stone vases, as often a grave with some good stone vases will have little or no pottery with them. Possibly this points to there being a difference of origin between the families who buried stone and those who buried pottery; or it may be merely that where stone vases were buried it was thought superfluous to add pottery.

The earlier types from 31 to 39 are essentially cylindrical, and these continue down to about 60 or 70. The later types are barrel-shaped, beginning about 43 and continuing to the end. In short the cylindrical types come in and go out with the black topped and polished red pottery; the barrel types go with the decorated and late pottery. But during the time when all the forms were in common use, from 45 to 60, there is no preference for either class of stone vases to accompany either class of pottery. There was no trace of separation between the users of the earlier and later styles.

A distinct conical foot is generally added to the cylindrical hanging vases; whereas the barrel vases only have a slight ring or beading around the base.

The stone bowls do not show distinct changes; on the whole the earlier forms are

shallower, and were probably used more as dishes. The later deep forms are much corroded inside by being used as drinking bowls.

28. The materials are of all kinds. At the beginning the soft limestone and alabaster were used, and also the hard basalt, syenite and porphyry. About s.d. 40 slate, grey limestone, and breccia came into use. Black lime-

stone appears at 51, serpentine at 61, and diorite was not used till 73, but continued to be the favourite stone in the pyramid times.

All of these stone vases were shaped by hand without any lathe or turning instrument, the lines of scraping and polishing running diagonally; the insides were ground out by blocks of sandstone or emery.

CHAPTER IV.

THE SLATE PALETTES AND IVORIES.

29. One of the most usual objects in the graves is a small slab of slate. When in a fresh condition these slates have generally some green paint on one side, and others have a hollow worn where paint has been ground. Bags of the green malachite used for grinding are found near the slate; and a brown pebble from the desert generally lies by the slate, sometimes with green paint also upon it, showing that it was used for crushing and grinding the malachite upon the slate. Thus there is every link of the process,—the colour in lump, with the palette, and the crusher, both coated with the colour. From lack of first-hand acquaintance with these slates some writers have named them amulets, &c.; but the facts of their condition, and the objects found with them, leave no possible doubt as to their use.

The surface is sometimes engraved with figures of animals; and in later times, at the beginning of the dynastic race, the slates were made of the same form, but larger, and covered with groups of animals and historical scenes. In all of these, however, the circular hollow for grinding the paint was carefully kept, and was the centre of the decoration.

Various forms of these slates are shown in pls. xi., xii., and the bulk of the forms is in *Naqada* xlvii. to l.; the sequence of the various forms is here given in pl. iii. The rhomb is the earliest form of all; two such are found in the earliest cemetery of s.d. 30, with bodies in goat-skins and single cups of black topped pottery. This form was probably suggested by some natural cross cleavages of the slate rock.

Immediately after that, there came in some elaborate animal forms, the stags in s.d. 31, the hippopotamus in s.d. 34, the bird in s.d. 35, the turtle or tortoise in s.d. 36, and the double bird about s.d. 40. All of these forms underwent degradation, slight at first, but becoming so great that the original form was entirely lost. The quadrupeds became irregular lumps with traces of projecting limbs, the turtles became notched discs, the fish became notched ovals, and the birds became rude lumps with a head. The square form came in at s.d. 37; by s.d. 53 lines were scratched along the sides; notches appear at 67, and zigzag borders at 72. Some of the latest have an Oxford-frame border (at 74), with rope pattern, and slight feet below. Thus rhombs and good animal figures belong to the thirties and early forties; squares and poor figures belong to forties to sixties; and notched and shapeless outlines are of the seventies.

30. The green paint, which is thus seen to be a standard toilet article, was used for surrounding the eye. On the earliest sculptures the face around the eye and below it is green, as on the figures of Sokhar-kha-bau (Cairo) and Abu-en-suten (B.M.). The purpose of using malachite was probably originally medicinal. Livingstone mentions that when in Central Africa he found that obstinate sores were best treated with powdered malachite, which the natives provided for him. A further use of coating the skin round the eye would be to stop out the glare of the desert, as the Eskimo blackens the skin to save the eye from the glare of snow. In the 1st Dynasty malachite-powder

is found as an eye paint, in a duck-shaped dish from Abydos (tomb M. 1); in the IIIrd Dynasty it is named at Medum; and it is found in the XIIth and XIXth Dynasties in tubes for eye paint. This custom of painting must have belonged to the earliest people that we know of in Egypt, as shown by their use of palettes.

THE IVORY CARVINGS.

31. One of the principal uses of ivory and bone was for the combs and hair-pins. The forms lately found are shown in pls. ix., x., and the ivories known before are in *Naqada* lix., lxi.—lxiv. The history of the various forms is given in the diagram pl. iii.

The earliest combs are fairly carved with deer (*Naq.* 59—63) or birds (*Naq.* 64, &c.); but they deteriorate, like the slate figures, though as they do not continue so late as slates they never become so corrupt. Plain combs without figures were also made in the thirties. Human heads are brought in at the forties. All of these combs have long teeth to retain a coil of hair in place, and the animals to serve as personal ornaments. They begin at s.d. 32 and continue common till s.d. 44; after that only two or three are known, and those very rudely carved.

The later combs were not for securing the hair, but merely to scratch the head; they have very short teeth, or a mere notching of the edge (*Naq.* 51—54). The same form is also found in limestone and transparent serpentine. These begin at s.d. 40, and are commonest at s.d. 57—60, after which they cease.

A combined comb and hair-pin (*Naq.* 53) came into use from s.d. 39 to 60; the short scratching comb standing out from the head as an ornament when the pin was in use. In one very well-preserved burial, this comb-pin, two bird pins, and a spoon were all stuck into the hair, see pl. vi., tomb B 378.

Other forms of hair pins have a small bird

carved on the top (*Naq.* 47—50, 75—84); and this was so usual in all periods, from s.d. 31 to 80, and on into the Ist Dynasty, that it is omitted in the historical diagram. There are also the flat pins, with or without a bird, which are early, from s.d. 34 to about 40. The round pin with a double bird head is later, about s.d. 70. It is strange how the retaining comb, to hold the back hair, disappears only a third of the way through the prehistoric; was long hair not worn later? Also how the scratching combs disappear two-thirds through, and nothing seems to take their place. The later prehistoric folk seem to have neglected their hair, and to have been on a lower level in personal matters as well as in artistic sense.

32. Another frequent use of ivory is for carved horns and tusks. Many pegs of ivory and bone are found, ornamented with spirals or zigzags (see pl. iii.; *Naq.* 1, 28, 29, 32, 39, 44—46, 95—97). These have always a groove around the thick end; and on some of these, and some similar pegs of limestone, portions of leather tying remain around them, and through the perforated holes. These were certainly ornamental, and attached to some leather work. It seems most likely that they were used for securing the leg holes and other openings in water-skins. These belong to the first period, beginning at s.d. 31, and coming down as late as s.d. 55.

Other carved tusks, about six or seven inches long, have a human face marked at the end, or a head carved in the solid (*Naq.* 35, 81). These tusks are found in pairs, one solid, the other hollowed. It seems not improbable that they belong to some magic operation, such as the catching of a man's spirit in a tusk, as negroes now do. These also are of the first period, ranging in date from s.d. 33 to 44.

33. Armlets and bracelets of ivory and bone are common in most periods, but they are thicker at the beginning, and become thinner in the later times (see pl. x.). Finger rings occur

early, at s.D. 34, 35. One ring has two lions attached to it (*Naq.* lxiv. 78), found in a grave of between s.D. 33 and 55. A larger ring has four hawks on it, see pl. ix. 23, and is later, of s.D. 71.

A very curious carving is that of a pair of sandals, painted in red, see pl. x. 19; these are as early as s.D. 32, and show how remote is the use of sandals.

Harpoons of bone and ivory are frequent. The earlier have two teeth and are well worked, in the thirties; later on only one tooth appears, at about the fifties, and the work is coarser (*Naq.* lxi. 12—16).

Spoons entirely belong to the later age. One curious spoon with a slate bowl, and a copper wire stem on which stone beads are threaded, occurs at s.D. 42 (*Naq.* lxi. 6). But the earliest ivory spoon yet known is in the forties or perhaps s.D. 50, delicately carved with thin bowl, and stem like a straw, widened for a small hole at the end (*Naq.* lxi. 8, and in diagram pl. iii.). The later examples are coarser and thicker, down to s.D. 74. Some elaborate

spoons have animals in relief upon the handle; one is but vaguely dated to between s.D. 31 and 63, the other not dated at all.

Of personal ornaments there are model tusks (pl. x. 27—29; *Naq.* 91—3), which begin at s.D. 38 and go on to about 70. Face pendants are usually of shell, but sometimes of limestone or copper (see end of diagram, pl. iii.); the earliest dated is of s.D. 50, and the latest is at s.D. 61. There are, however, some more elaborate ones carved in patterns or as female figures; but as they have only been obtained through dealers their age is unknown. That these oval plates are intended as forehead pendants is shown by their curve well fitting the forehead, and one being found in place on the forehead of a skull. The hook at the lower end of some appears as if intended to hold up a face veil. If so it would be the prototype of the modern gold ornament for the forehead, through which the face veil is held up. Though the usage of a face veil has not been continuous in Egypt, it may have been brought in from the Arabian side twice over in history.

CHAPTER V.

TOOLS OF STONE AND METAL.

34. The earliest examples of finely flaked flints are those in graves at s.d. 32; as, however, only about one grave in twenty contains worked flints, the absence of any in the dozen graves of s.d. 30, and about twenty of s.d. 31, hardly implies that they were not then in use. Those found at s.d. 32 are splendid examples, the largest of the double-edged knives, about fifteen inches long, and the forked lances with a shallow space between the prongs (see the types at the top of the diagram of flints, pl. iv.; *Naqada* lxxii. 52, 66). Following on these is the knife with rounded butt and curved blade, beginning about s.d. 33. The flaking in the earlier examples is quite irregular; and though they are worked down very thin, still the power of regulating the chips seems not to have yet been acquired. Even at s.d. 38 there is only the beginning of serial flaking along the edges of the forked lances. And the same is on the edges of the pointed lances at s.d. 40 (see pl. vii., fig. U 259). At s.d. 45 there is more regularity in the position of the surface flakes of the long scimitar knives (*Naq.* lxxiv. 84); but still each flake is quite ragged at its edges. The true serial flaking, in which each flake has smooth edges and a regular width, was first developed on the triangular knives. These knives are rough, and with but little detailed work, in the thirties (see top of diagram, pl. iv.; *Naq.* 64); but in the forties they were worked up with flaking across most of the wide face, and completely regular all along the back. This serial flaking was almost perfected at about s.d. 56 (see the knife B 191 of that age on pl. vii.); and the finest specimens belong to

s.d. 58 to 66 (see B 217 of s.d. 66, pl. vii.; and *Naq.* 82, 86 of s.d. 58). After s.d. 66 no such fine work is found; in the seventies it becomes coarser, and the body of the flint is thicker. In the Ist Dynasty the regularity of flaking has entirely disappeared, and was never recovered. We see in this history of flaking how consistent the course of it is, as traced out by the sequence dates.

The method of grinding the surface before the final flaking seems to have been necessary for the best serial flaking; and the long regular flakes could only be struck on the flat surface of either a large natural flat fracture or an artificially prepared ground surface.

35. The forms of the flints show a regular order. The bilateral types are the earlier (see diagram, pl. iv.). The long double-edged knives have been first found at s.d. 32, of a large size; the smaller sizes continue to about s.d. 45. The pointed dagger with rough tang occurs from s.d. 40 to 52; with a round butt at s.d. 56. The forked lance is wide and shallow in the fork at s.d. 32 to about s.d. 43; the saw edge begins at s.d. 32, but the knife edge form at s.d. 35. The fork becomes deeper at s.d. 38, and continues thus to late times. The separate outline of the tang is a late form of about s.d. 70.

The earliest unilateral knife is of the rounded butt "comma" type, beginning probably by s.d. 33, and continuing certainly till s.d. 39, and probably later: small examples are found at s.d. 56. It seems to be succeeded by the scimitar knife, which lasted from s.d. 45—65. The triangular flake knife began in the thirties,

developed to a larger size by about s.d. 40, and continued to s.d. 61, or in a slighter, narrower form to the end of the prehistoric. Probably from this type the fine serial-flaked knife was developed; this is first found at s.d. 57, and on to s.d. 66; while the same outline with coarser work lasts on to the age of Mena.

The circular scraper (*Naq.* 32) is found at about s.d. 40, and probably continued later, but is not dated. The square-ended flake is first found (*Naq.* 99) at s.d. 63, rather irregular; at s.d. 70 it is finely parallel in its planes (*Naq.* 97), and continued thus until the Ist Dynasty, when the ends were more usually curved.

36. Lastly, in the same diagram, pl. iv., are shown the mace-heads. These are made of various stones; syenite, porphyry, and rarely alabaster, for the disc form; basalt, haematite, breccia, alabaster, but mostly hard white limestone, for the pear form. On looking to the dates the disc form is clearly the earlier; it begins at s.d. 31, and is rarely found after s.d. 40, ending at s.d. 53. The pear form, on the other hand, is not found before 42, is most frequent in the fifties, and continued on to the Ist Dynasty, or even to the IVth Dynasty in actual examples. The general use of white stone for the pear mace-head gave rise to its being figured for the idea of "white" or "bright" in the hieroglyph *hez*.

The actual examples of the disc mace-heads, with handles complete, are shown in pl. v., grave B 86, which is between s.d. 35 and 40. One handle is of ivory, the other of horn; they were found in a rich grave, containing also the seven forked lances and two other flints shown in pl. vii.

METAL TOOLS.

37. We turn now to the metal tools. These appear to be of copper, so far as the condition of the metal shows; it has very little oxidation or change, and is still quite flexible. For the forms and their dates see the diagram on pl. iv.

The earliest use of metal in Egypt seems to have been for pins to fasten the goat-skins round the body; one such was found in the oldest group of graves (s.d. 30), the shallow circular pits with one or two black topped pots in each, and the bodies wrapped in skins. Next after that, harpoons were made of metal; a small one occurring at s.d. 34—38, and larger ones at s.d. 54 and 61. The forms of these were copied from bone harpoons. The third use of metals was for small chisels for wood-working, which appear at s.d. 38 and onward; the large chisel has not been found before the close of the prehistoric at s.d. 78. After these uses there comes the first needle at s.d. 48, or perhaps even at s.d. 43; and the broad curved flaying knife at s.d. 49. All of these tools are on a small scale, showing that copper was yet valuable. The first large tool found is the adze for wood-working, beginning at s.d. 56: it became thicker and with a rounded top at s.d. 78; and had the same rounded top at the close of the IIIrd Dynasty. The very well-formed dagger appears in a grave which must be dated somewhere between s.d. 42 and 63, and probably between 55 and 60. Fortunately it was found with the best authentication; I was clearing the grave with my own hands, and there was a green stain on the thigh bone where the copper had rested; the objects in the grave were clearly of a good prehistoric age, and there was no trace of disturbance. The rarity of such weapons is fully accounted for by nearly all the graves having been plundered for metal at an early time: this grave was one of the very few intact ones that we found. The curious double-ended blade, at the base of pl. x., is very late, being of s.d. 80, or perhaps therefore in Dynasty 0. The form, sharp at both ends, is unique; and it looks as if it must have been mounted across a handle, T-shape, so as to cut both ways; see the double axe in "Royal Tombs," vii. 12. A bodkin of thin sheet copper was found with some very slender needles at

s.d. 71. And a grave of s.d. 78 yielded a fine set of an adze, chisel, and axe-blade, all of which are now in the Cairo Museum, and are shown in the last group on pl. vii.

38. A copper-foil face-pendant is found at s.d. 61. Strips of copper sheet were used for bracelets at s.d. 34 and 42; and copper wire for bracelets later on, at s.d. 52 and 57. Copper wire was used for lashing woodwork at s.d. 62, and this use continued on to the Ist Dynasty, when much copper wire lashing and binding is found. This wire was not drawn, but cut and hammered; just as in Exodus xxxix. 3, "they did beat the gold into thin plates, and cut it into wires, to work it in the blue." There is no example of drawn wire in ancient Egypt so far as I have seen, but it is always faceted with a hammer.

39. Of other metals there are but few

examples. Silver beads are found at s.d. 42, a silver spoon between s.d. 57 and 64, and a thin silver ring at s.d. 61. Gold is found in a sheet pendant (*Nag.* lxxv. 16) at s.d. 44; a gold wire ring between s.d. 46 and 52; and small gold beads between s.d. 49 and 53. Thin foil of base gold was also worked over beads of limestone. Of course the minute quantity of gold and silver that we find is but a small fraction left behind after very active plundering in the past. An armet of a hard white metal was found, of between s.d. 32 and 48; it is not yet analyzed, but may be a silver-copper alloy. Lead we know to have been used early, as a prehistoric statuette shows us; and a piece of a sheet lead hawk dates between s.d. 44 and 64. As galena is often found in the graves, placed with malachite as an eye paint, it is natural that metallic lead should also have been known.

CHAPTER VI.

AMULETS AND BEADS.

40. Amulets in general are not found till well into the second prehistoric age, at about s.d. 50. But perhaps the rudely formed human figures and animals, of slate, ivory, and alabaster, found at about s.d. 40, may be included as amulets. The figures are of two classes, rounded and flat. The rounded are of ivory (with a pot on the head) at s.d. 38; of vegetable paste moulded on a stick and painted red and black at the same age; and of ivory and alabaster, of uncertain age (see *Naq.* lix. 7, 11, 3). The flat forms are of slate at s.d. 38 and 41, and of bone at s.d. 42 (see *Naq.* lix. 2, 4, 8—10). But possibly the rounded figures may represent buried slaves, as a row of four figures was found (*Naq.* p. 21); and the smaller flat figures may be objects for exorcism or magic; at least none of these were worn about the body.

41. The oldest form of amulet found is the bull's head, the first in the diagram pl. iv. The origin of this form was a puzzle until an example was found at Abydos, on which the flat front and muzzle form of the lower end left no doubt that it must be copied from a bull. It begins at s.d. 46 or earlier, and continues in use till s.d. 67, when it is very degraded. A form apparently continued from this is found in blue marble with beads of the XIIth Dynasty, so it may even have lasted on as late. But the connection with the bull's head had disappeared early, while the idea of such an amulet seems to have continued, as we find well-made bull's head amulets of carnelian at about the close of the prehistoric (base of diagram), and such continued to be used in the Vth and VIth

Dynasties, gradually dwindling in size. We can hardly avoid connecting these with the large numbers of painted skulls of oxen and sheep which were prepared to hang up on a wall, and then buried with barbaric Libyan (?) invaders after the XIIth Dynasty, as described under the Pan Graves, later on in this volume. Looking to the west we find bronze bull's head amulets in Spain, and large bronze bull's heads to hang up on buildings in Majorca (*Rev. Archéologique*, 1897, 138); gold bull's head amulets are found in Cyprus and Mykenae; and at present cows' skulls are hung on houses in Malta, and on fruit trees in Sicily and Algiers, to avert the evil eye. The whole subject of bucrania is opened by these prehistoric bull's head amulets.

42. A favourite amulet was the fly. It begins about s.d. 48, is found at s.d. 60 and 67, and reappears in historic times on necklaces of the XIIth and XVIIIth Dynasties, and on a large scale in gold as a token of royal favour in the XVIIIth. The prehistoric materials are slate, lazuli, and serpentine.

The hawk is found as a flat figure in serpentine, at s.d. 56 and 67. But rounded figures on a larger scale were made in glazed quartz, limestone and bone (see *Naq.* lx. 14, 15, 18—20). It continued to be a favourite amulet in the XIIth Dynasty and later. Other animals found are the crocodile, in serpentine, at s.d. 52; and the frog, in limestone, at s.d. 65.

An unexplained form is a sort of trident, in serpentine, at s.d. 52. It seems like the hieroglyph  in its earlier form, as in *Medum*

xxi. A ball-shaped amulet might possibly be intended as a vase; much such a form occurs in polished red pottery, mainly about s.d. 50 to 70, and this amulet is always in red carnelian beginning at s.d. 68 and going on to 80. A vase amulet continued to be used in the VIth to XIIth Dynasties. The claw amulet is in serpentine and red porphyry; it occurs at s.d. 60, along with the spear-head in serpentine. A late amulet is the scorpion made of carnelian; beginning at about s.d. 70, it continues till 80, is after that abundant in the stone and glazed figures of Narmer (probably before Mena), and continued in use in the VIth and XIIth Dynasties.

We are at last in a position to attempt a history of amulets in Egypt. Till a few years ago none were known except a few of the XIIth Dynasty and the usual mummy amulets of late times. Now we have the prehistoric amulets discriminated in period, and those of the Vth, VIth, VIIth, IXth, XIIth, XVIIIth and later Dynasties, all well known.

BEADS.

43. The beads, which are found abundantly in the prehistoric graves, have been very completely catalogued and classified. But it does not appear that any of the forms are characteristic of any one period. Small ring and tube beads of glazed pottery appear in all ages from s.d. 31

to 80. Disc and cylinder beads of stone are similarly of all ages. The only types which may be delimited are perhaps the disc beads faceted with an edge round the middle—the frustra of two pyramids joined, and the tube beads of drop form thickening at one end, both of these seem to belong to the sixties and seventies.

The case is different, however, when we examine the materials. Some run through the whole time, such as quartz, agate, carnelian, brown and white quartz pebbles, steatite, calcite, and glazed pottery. These are therefore not placed in the diagram on pl. iv. But other materials have a definite range; and some are only known in a brief period, such as green glazed stone s.d. 52—57, blue glazed stone 52—73, turquoise 55—63, amethyst 55 and 70. Broadly, the materials used before s.d. 40 last on through all the time; while one group (lazuli, serpentine, haematite, and silver) came in at s.d. 40, and disappear about 60; and another group (turquoise, amethyst, obsidian, porphyry, and gold) belong to the fifties. This implies a growth in resources up to about s.d. 60, and then a rapid decline; exactly what is seen in the styles of the pottery.

Some other materials may very likely have longer ranges than have yet been found, such as shell, beginning in s.d. 53, coral tubes in s.d. 36, 38, and limestone in s.d. 48, 52.

CHAPTER VII.

OUTLINE OF THE PREHISTORIC PERIODS.

44. Having described the various classes of objects found with the prehistoric burials, we may now sum up the results that we gather as to the changes during the whole period.

The earliest graves of all, in cemetery C, are here termed s.d. 30. They are all shallow circular hollows in the marly rock; the bodies are all contracted, and have usually one black topped cup, and no other furniture. In one case a copper pin was found, showing that metal was already known. According to one school this debar us from calling this age neolithic; but a more reasonable school agrees in including the age when stone was still the main material, as being neolithic. On this terminology the prehistoric age, certainly down to s.d. 60, should be called neolithic, if not even down to dynastic times. Where, then, are we to look for the people ignorant of metal, if the earliest graves known contain copper? Was there ever an entirely neolithic people in Egypt? There are palaeolithic implements abundantly, both in the high Nile gravels, on the top plateau, and on the surface down to the present Nile level. Palaeolithic man continued in the land until its present climate was reached. A fixed population, such as we find among neolithic people elsewhere, was, however, an impossibility without cultivable land. And no land can be cultivated in Egypt except the Nile mud. How old, then, is the deposit of Nile mud? Several borings have shown that there is a depth of about eight metres of deposit; and as various data agree on a metre being deposited in 1000 years (or even 800 years),

the age of the deposit, if uniform, is about 8000 years. As our dating reaches back over nearly half of the period, it is a good scale to trust; but as the deposit may naturally have at first increased gradually, perhaps 9000 years would be the most reasonable age for cultivated land in Egypt, or beginning at about 7000 B.C. It is improbable that any but nomadic hunters lived in the land before that time.

45. Now historically we must place the dynasty of kings before Mena as beginning about 5000 B.C. And for the length of the prehistoric age there is no direct evidence; but looking to the number of graves as compared with historic times, and to the changes of styles and of people, it would seem that 1000 years would be decidedly too short a time to allow, and that 2000 years would be more likely. Thus we are led to place the earliest graves to about 7000 B.C., which is as soon as there seems to have been any opening for a settled population. It is, then, useless to look for the earlier stages, before the use of metal, in Egypt itself; rather should we suppose that a Libyan people passed through the neolithic stages, and acquired copper, while Egypt was yet the haunt of palaeolithic wandering hunters; then, as soon as rich and fertile soil began to accumulate in the valley, the copper-users pushed in and occupied the land. So fine a land, with the stimulus of the mixture of two races, gave that start which enabled the rude people wrapped in goatskins to rapidly develop within two or three centuries the skilful prehistoric civilization which we find at about s.d. 35—40.

The conclusion, then, is that the palaeolithic

hunters occupied Egypt until the beginning of the Nile deposits, about 7000 B.C. Then came in a Libyan race, already pastoral and probably agricultural, making pottery, and knowing the use of copper. These people in a century or two developed a profusion of fine hand-made pottery, black topped, red polished, and ornamented with white cross lines; also stone vases of limestone, alabaster, basalt, &c.; carved slate palettes, carved ivory, splendid flint work, and the art of weaving. A free use of personal signs for marking property is also found. This civilization shows no signs of weakness or decay for some centuries, but seems to have settled into a permanent condition from about s.d. 32 till near s.d. 40.

46. But wide-spread alteration begins to show itself about s.d. 38; we can roughly estimate its place by tabulating how many classes or styles begin or end in each unit of s.d.

	s.d. 38	39	40	41	42	43	44	45	46	47	48
End ...	1	1	2	-	2	4	3	-	1	-	1
Begin ..	3	3	4	1	4	2	-	-	2	-	-

Thus new classes were beginning actively in s.d. 38—40, and freely on to s.d. 43. While old classes were vanishing mainly at about s.d. 40—44. This probably marks the influx of a rather different people at s.d. 38—40, and their styles driving out those of the older people from 40—44. Roughly, the influx covered two or three generations, and the subsequent changes took effect in four or five generations. We will now note these changes in each class.

In the pottery; the starting of new types of black topped slacked greatly at s.d. 39, and scarcely any new ones begin after 43; the red polished pottery has very few new types after s.d. 43; the cross lined was extinct in 35; new types of fancy pottery cease to arise after s.d. 40; the decorated pottery types are very few, perhaps only imported, until 40, when they

suddenly spring forward; the late pottery begins practically in 43.

In the stone vases; the tubular forms with handles cease at s.d. 40; and the barrel forms begin at s.d. 39 and are in full career by 42.

In the flint working; the forked lances begin the deep V notch at s.d. 38; the round butt knife ceases at 39; the pointed lance begins at 40; the finely-flaked triangular blade begins at 41; the long bilateral knife disappears after 43, and the sickle knife begins at s.d. 45. The mace-heads show a sharp change; the disc mace is almost extinct in s.d. 40; and the pear mace is not found till s.d. 42.

In the slate palettes; the rhombs almost cease at s.d. 42; the animal forms greatly degrade after 40; the squares begin at 37; and the double birds begin at 40.

In the ivories; the long-toothed combs almost disappear after s.d. 44; while the notched combs begin at 40; the flat hair-pins cease at 40; of spoons the earliest is at 42, and they are not usual till 50; the model tusks, perhaps amulets, begin s.d. 38.

In the beads, silver begins at s.d. 38, lazuli at 39, serpentine and haematite at 40, after which there is no new material till the fifties.

In the amulets, &c., human figures range from s.d. 34—44, after which they are very rare; the steatopygous statuettes belong solely to the early times, 35—38, and may represent survivals of palaeolithic race. Animal figure amulets begin at about s.d. 45.

The animal signs on pottery cease after s.d. 46; and signs in general are commonest from s.d. 30—48, greatly checked from 48—64, and almost extinct from 64 to the end. The boat ensigns are first seen at s.d. 35; they become common at 44—55, and finally cease at 63.

The multiple burials are common before 40 and last to 43. Single burials belong to the later age.

We now see how almost every kind of product was changed at about s.d. 40; and that we must

look probably to some new influx of people to account for such a wide-spread difference. Many of the things are similar in character but different in form, and therefore the earlier and later people were probably of the same stock but diverse in the development of their civilization. The earlier people seem to be connected most with the west; their most characteristic pottery, with white lines, is closely like that of the modern Kabyles, and their disregard of amulets is like the same people. But the second people show more an eastern affinity; they used amulets largely, and also the face pendant, implying a face veil, both of which are Arabic customs; their characteristic pottery was the wavy handled, like the early pottery of Palestine; and they brought in silver, lazuli, and haematite, all Syrian products. We are led, then, to regard the earlier race as Libyan, and the later as Syrian, probably of the Amorite stock, which was one in origin with the Libyan.

47. After the fine early time of the thirties, which was the best artistically, the age from s.d. 50—60 is the acme of the prehistoric civilization. We see then the most elaborate flint working, with perfect serial flaking; the best metal work, with the beautiful copper dagger; the more valuable beads of gold, turquoise, and amethyst; the greatest profusion of hard stone vases; and the greatest amount of decorated pottery (perhaps rather from 45—55). We may suspect some fresh influx in this age, as at about s.d. 60 is a time of change, the close of some classes, as the decorated pottery,

the combs, the carved tusks, the boat signs; and the beginning of standing stone vases of barrel form, deep stone bowls, and coarser flint work. Such may, however, only have been natural changes in the people; and there is no such break as took place at s.d. 40.

After s.d. 60 there is only a steady degradation in every respect. The finer kinds of pottery disappear; the decorated becomes quite rude, with only rough parallel lines; there is hardly any but the rough and late kinds, and they are coarse and poor in form. The stone vases are clumsy and scarce, the flint working becomes coarse, the finer stones for beads disappear, the amulets are reduced to only two or three forms, the slate palettes have lost nearly all trace of their original types, and ivory working is rare. The poverty of material, of taste, and of ability is painfully clear in all of the graves of this decadent age.

48. There is apparently some interval between s.d. 80 and the first Dynasty; as the pottery of Narmer is later than anything that is classed as prehistoric, though it still shows a very degraded form of the black topped pottery. Under Mena the types are all clearly later than those forms found at s.d. 80; and in the Ist Dynasty tombs we see a steady drift onward into still more divergent forms. It seems then that provisionally we should put the time of s.d. 80, or the close of our present scale of the prehistoric, to the beginning of the Dynasty of Thinis, 350 years before Menes, the first domination of the dynastic race.

CHAPTER VIII.

THE CEMETERIES.

49. The map of about ten miles of the desert edge between How and Semaineh is given on pl. i. : it is divided in four pieces of two and a half miles each, to fit the page. It was planned by using the telegraph poles, which are marked here by spots, and each tenth pole here numbered. The deflections of the line of poles were noted approximately ; and the various valleys were sketched in with paced distances. Such a plan is sufficient for showing any topographical points that need reference ; and the exact relation of it to a general map of the country can always be fixed by the dyke to How, and the village of Shekh Ali. It is approximately north upward.

Beginning at the top we see first the XVIIIth Dynasty cemetery, which had been thoroughly plundered by dealers recently. Behind it is the Coptic cemetery attached to the Deir, which is used by all the Copts of this district. Our relations with the priests were very friendly, and they allowed Mr. Mace to work close up to their present cemetery. Next is the cemetery Y ; of the VIth to the XIIth Dynasty, and the shallow surface graves of the XIIth to XVIIIth Dynasty marked YS. In the sides of the valley are long shallow graves of the VI—VIIth Dynasty. On the tongue of land in the valley is cemetery X of the Pan graves, the burials of foreign invaders just after the XIIth Dynasty. Cemetery W is of XIIth Dynasty, with reburials of XVIIIth Dynasty, and a great quantity of late Ptolemaic and Roman burials near the Fort.

The Fort (see pl. xxiv.) was originally the temenos of a late Ptolemaic temple, to which

were added round bastions in Roman times, probably of the IIInd century, when the garrison of Diospolis Parva lived here. Our huts were built against the north end of the east side, overlooking the valley. The west side of the valley is covered with Roman potsherds. The tongue of land in the valley and the east side are pierced with dozens of old rock tombs ; but so many burials have been made here in recent times (particularly from the fatal accident at the Farshut bridge, the many deaths from which were largely concealed) that the natives will not allow the graves to be examined. From the square Shekh's tomb at the corner for half a mile inward are many modern tombs, up to the great modern cemetery, at which it is said that seventy towns and villages now bury. As there is no other dyke up to the desert for many miles, this is the only outlet for the burials of a large population.

The cemetery U at post 180, is entirely of the prehistoric, beginning at the earliest age. It was cleared by Mr. MacIver. About 140 to 150 are little patches of cultivation in the mouths of the valleys. At post 126 is the cemetery R, which is also prehistoric, cleared by Mr. MacIver. Behind 120 is a mound with Roman pottery, back in the desert, which would seem to have been an outpost fort, about four miles from the large fort at Diospolis. After passing low broken ground, much used for Arab encampments, we reach the village of Shekh Ali. Just east of that is the cemetery N, the only important tomb in which is of the VIth Dynasty. On the next hill east is a cemetery of the IVth—VIth Dynasties, entirely destroyed by dealers ;

and beyond that the site of a prehistoric village, also entirely plundered.

The cemetery A is also of the Old Kingdom, with XVIIIth Dynasty reburials, but entirely plundered, as well as the mastaba. Our huts were built here for our work of the earlier half of the season, before we moved to the fort of Diospolis. This region belongs to the village of Abadiyeh.

The fine cemetery B provided a large quantity of good prehistoric things; and the isolated hill C, with shallow circular graves, seems to be the oldest cemetery that has yet been found. D is a group of mastabas and tombs of the VIth Dynasty, shown in detail on pl. xxiv. At L, M, E are a few tombs of the XIIth–XIIIth Dynasties. At F are prehistoric settlements.

H is a prehistoric cemetery of the later period; and the great cemetery J is of the early XVIIIth Dynasty, but utterly plundered of late years by dealers, being the source of all the objects described as from Semaineh. K is a Roman cemetery. Beyond that is the large modern cemetery, in which a great festival is held at Beiram, attended by thousands of persons.

50. Having now described the general position of the various cemeteries, the peculiar and important graves in each cemetery will be noted here, first taking the cemeteries of prehistoric age, A, B, C, H, R, U; and then those of historic periods, D, E, N, W, X, Y.

Cemetery A. This was nearly all of historic age. In one place was a curious burial of very large black topped jars (B 22a); five lying side by side, flat in the ground: the longest was 26 inches high.

A 13 was a very late prehistoric tomb of brick, with top roofed by bricks on end leaning together; the burial of a child was full length, in a wooden coffin, with pottery, F 25m (pl. xiv.), R 26, L 17g.

Cemetery B was one of the largest and best, and was carefully recorded by myself. B 17

(s.d. 30–50) was the intact grave of an elderly man, contracted, head S.; only 14 lower vertebrae were in line, the skull placed with its base against the upper vertebra, facing backwards, the jaw detached, in front of the face; one scapulâ and arm united, the other scattered. A jar by the head contained 36 scarab beetles, two-thirds full grown, a third small.

B 18 (s.d. 57) had 10 jars and bowls in place; on the top of the ashes in a jar was a film of brown matter, apparently dried dregs of *buzeh* beer.

B 24 (s.d. 41–65), the trunk was dried in one piece with the skin on, the skull before the chest, and a piece of skin with hair laid over the severed end of the spine; one humerus in place, but all other long bones scattered.

B 37 (s.d. 31) two bodies superposed; the lower buried without flesh, a goat skin being wrapped close against the bare sacrum and lumbar vertebrae on the inner side; the upper body entirely dissevered, only 4 vertebrae together, no ribs attached, the long bones completely separated, and stacked in handful together, scapula between jaws, left condyle broken. Over both bodies was a covering of goat skins.

B 51 (s.d. about 40). Body destroyed, but objects apparently placed in front near the hands: see photograph of group pl. vi., slate, pl. xii.

B 56 (s.d. 34), parts of two bodies left. Pottery and stone vases at north end, with clay balls; see group pl. v., and stone vases on pl. ix.

B 57 (s.d. 47–62), see group pl. vi.; the copper bangles were on the arm, the stone vases in front of the elbow.

B 60 (s.d. 62–64), a curious small square pit, 35 × 20 inches, with four jars, but no body.

B 83 (s.d. 33–48), see group, pl. vi. The grave was broken up, and the clay toys scattered in the filling; the most remarkable is the model of the town wall, with men looking over it.

B 86 (s.d. 35—40) was one of the finest graves, having two bodies, contracted, one before the other, and a third body further along in the grave. Of the first two bodies, one had no head, and of the other only the pelvis, one thigh, and the shins were there; the third body was quite complete. The grave appeared to be quite undisturbed, and had behind the imperfect bodies two maces with an ivory and a horn handle complete (see pl. v.), the only handles yet found (Ashmolean Museum). Behind the perfect body were the nine flint lances, &c. (see pl. vii.), and another disc mace head. It would seem that the perfect body was the main interment, and the others were portions of relatives who were re-interred here.

B 101 (s.d. 34) was the largest and fullest grave that I found, although the body had been plundered out. The top was roofed over with sticks $1\frac{1}{2}$ to 2 inches thick, placed about 8 inches apart, and covered with matting: such covering to graves is therefore quite early in date, although it was the prototype of the roofing of the royal tombs of the 1st Dynasty. At the north end of the grave was a great mass of fine pottery of nineteen varieties (see groups on pl. v.), hippopotamus and rhombic slates (see pls. xi., xii.), six whitened clay models of ostrich eggs, one very large one with black zigzag lines imitating cordage around it, paste figures, stone hippopotami, stone cones with leather, ivory combs, clay beads, &c. One arm of a girl remained with carnelian bead bracelet.

B 102 (s.d. 33—41) was another important tomb (see groups on pl. v.), with five bodies. One man was on his back, but with sacrum, shin, and arm bones stacked together at the middle of the body; a second man had no head, and the long bones were stacked together; the third was only a cluster of leg bones; the fourth was a man's head with bones entirely confused; the fifth was a child in the corner; beside these, two skulls of women lay uncon-

nected in the grave (see 3 vases and 2 combs in pl. ix.).

B 103 (s.d. 35) was another joint grave, the bodies were all contracted as usual; at the back a man; close before him, with pelvis in contact, was a woman; on her thigh another woman, and on her thigh a third woman.

B 107 (s.d. 33?) another grave with three bodies, but disturbed.

B 109 (s.d. 44) a fine burial of a woman, with many small objects placed in front of the body (see pl. vi.; slates, pls. xi., xii.).

B 119 was all disturbed; it contained a dog's skull, an ox bone, a mace head, and clay figures of a man, a chisel, and a hoe (see pl. vi.).

B 125 was a family grave; at the back a fine man, a young woman close before him, an old woman before her, and another old woman beneath the latter.

B 140, a joint grave; a man at the back and a woman before him.

B 190 (s.d. 65) contained a large square cist of pottery (see pl. vi.), with three rough jars outside of it, and two small vases and four saucers, all rough, inside it.

B 217 (s.d. 66) was one of the largest graves, 80×220 inches. The body and all the middle was plundered out, but in the filling were the pieces of a large flint knife (pl. vii.), now at New York. The north end still contained 24 jars of R 80 type, and 6 pans; the east side 40 pots, mostly small. In the north-east corner stood a large jar (L 40 type) full of thousands of small beetles and dozens of the larger desert beetle, but no true scarabaeus beetles; in another jar were two large and many small scarab beetles. These jars, and the jars of beetles in B 17, B 234, B 328, show that the scarab was already notable in the prehistoric time (though not necessarily before s.d. 50), and prepares us to find it used as an amulet in the Old Kingdom. For the stone jar see pl. ix.

B 234 (s.d. 66) a long grave, 35×75 ; the body contracted at the south end, and at the

north end four jars and a bull's head and horns complete. The spine was completely ankylosed from the top to the sacrum; but the head was off, and turned base to the wall, with unbroken pottery placed over it. A pointed jar (type B 53b) was before the head, with scarabaeus beetles in it.

B. 236 (s.d. 43—48) contained four bodies of men, with flint lances and stone vases, see pl. vi.

B 323 (s.d. 60) contained many pots, but no bones; also a lazuli fly pendant with gold head, and a forehead shell pendant (pl. vii.).

B 328 (s.d. 53) had many jars, two stone vases (H 9, H 43 types), and two jars with beetles in them.

B 378 (s.d. 52) was an oval pit with a recess at the side for the body of a woman, quite complete, with three hair-pins and a spoon stuck in the hair. The head, intact, is photographed, also the group of objects, and the hand with a copper bangle on it, pl. vi.

B. 379 (s.d. 66), a very perfect burial of a man is photographed intact to show the character of these burials, pl. v. It is not usual, however, for the face to be turned upward in this manner. A fine late decorated jar is in the corner, D 78b on pl. xvi.

This cemetery B went up to 570 graves, but there was nothing new or important in the others. The position of the bodies, on left side, head south, is fully described in *Naqada*.

51. Cemetery C was on the top of a low, isolated hill of the desert edge. The graves were not long, oval, or straight-sided square, as in the cemetery B, but were all circular, generally about forty inches across and 10 to 20 inches deep, in soft marly rock. The bodies were all contracted, except one on its back with knees bent. A regular example is shown at the beginning of pl. v. The bodies of which the sex is recorded are five men, three women. The pottery is almost all black topped, generally a

single cup of elementary form; the types are B 19a, 21b, 22b, 22f, 25b, 25f, 29a, 84, 85, P 17. The slates are only two rhombic (pl. xii. 47), one with a brown jasper grinder pebble under it. In one grave was a string of brown steatite beads, small discs, with a brown and white quartz pebble pendant, around the neck. In another grave was a small copper pin. This was the sole furniture in sixteen such graves that we found. The bodies were wrapped in goat skins, and a lump of skins thrown in over them in some cases.

From the very early style of the pottery, the single jars placed with the bodies, the absence of woven cloth, and wrapping in goat skins, and the different type of the grave (like that of the Libyans of the XIIIth Dynasty), it seems that we must see in these the earliest stage yet known of the continuous Egyptian race, the first successors of palaeolithic man, that have yet come to light. This group is therefore dated as s.d. 30.

By the side of C, at the mouth of the valley of B cemetery, some pits were sunk to see what the valley bed consisted of, and if there were graves under the blown sand. The results were:—

Near cultivation. 30 feet south. 60 feet further.

Blown sand 90 inches 80 inches 40 inches

Under the blown sand and pebbles was a sloping bed of clean water-laid sand, into which we sank 90 inches more, interstratified with layers of marly mud two or three inches thick. This must be the Nile deposit of the ages before the present low Nile; the blown sand over it proves that it is not of recent times, and in the prehistoric days the Nile was some 20 feet lower than at present, having raised its bed by deposits since. So we see that the desert valleys were eroded, and then filled with Nile wash before the low Nile age, and that about seven or eight feet of blown sand has since accumulated in the valley mouths. Further west, in the valley mouth west of cemetery A, we found a wide-spread burnt stratum about eight feet down,

the result of great fires, as the sand was reddened for nearly a foot deep. It seems not impossible that this was one of the burning places for the prehistoric offerings, of which such great quantities of the ashes were buried in jars in the graves.

52. Cemetery H was worked by Mr. Mace and Mr. Iles, and the following results are from their notes. All the burials are late prehistoric.

H 14 (s.d. 58—75), a contracted burial, with bones approximately in place; but the leg and arm bones wrapped up, fibula and tibia each wrapped and then joined, knee-caps in place. Skull on knees, no jaw-bone.

H 16 (s.d. 69), balls of both thighs turned away from their sockets; bones wrapped in bark, tibia and fibula together; lower vertebrae wrapped round. Upper part of body plundered.

H 17, 18 (s.d. 60), 27 (s.d. 72), 30 (s.d. 77), 31 (s.d. 73—79), 36 (s.d. 78), bones wrapped in cloth separately.

H 36 (s.d. 78), not only were the bones each wrapped separately in bark fibre and rejoined, but the skull was wrapped up with a carnelian bead in each eye.

H 39 (s.d. 72), only two vertebrae remained with the head; all the other bones were piled in a square heap.

H 56 (s.d. 72) had a square wooden coffin: body perfect, contracted. Remains of a wooden figure by it, eaten by white ants.

H 60 (s.d. 80), a similar burial.

H 76 (s.d. 68—78), lower bones, pelvis, most of vertebrae, and one humerus in place; other bones neatly piled over pelvis.

H 86 (s.d. 74), complete skeleton, contracted; string of blue glazed beads around head.

H 90 (s.d. 80), complete skeleton, contracted, in wooden coffin; necklace and right armlet of carnelian; behind head a basket of ashes.

The whole of this cemetery is of small oval

graves; there was not one large square grave, nor any but single burials. Though cemetery B comes down largely to the fifties and sixties, yet no multiple burials are found in it later than one at 43, and six other such are all before 40. They seem, therefore, to belong to the earlier prehistoric people. Whereas cemetery H, which is entirely after 60, and nearly all after 70, has not one multiple burial.

53. Cemetery R was partly worked by Mr. MacIver, partly by Mr. Mace. It has a few burials of the earlier age, but is mostly of the later prehistoric, 50 to 80 s.d.

R 4 (s.d. 58—76), bones all sorted, and laid out side by side in a row; arm bones, leg bones, pelvis, ribs, and head.

R 5 (s.d. 70), scarabaeus beetles in a wavy-handled jar.

R 18 (s.d. 76), two scarabaeus beetles in a jar.

R 111 (s.d. 72) upper bones all packed into a square foot, the humeri sticking straight into the ground, head in centre, one ilium on top of it, ribs jammed around; all flanked by the pots which held the pile together.

R 112 (s.d. 70), leg and arm bones packed together parallel, scapulae, pelvis, &c., missing.

R 121 (s.d. 56), a double string of small carnelian and blue glaze beads around head, just above eyes.

R 134 (s.d. 41), body contracted in middle of larger square tomb: pottery and turtle slate nine inches over it in sand; large pottery hippopotamus at west end (pl. vi. bottom), and two quadruple pots, type D 91c, pl. xvi.

54. Cemetery U was a large and important one of all prehistoric periods, worked by Mr. MacIver; it contains about twice as many graves of the thirties as of any other decade, but is otherwise nearly uniform down to s.d. 80.

The graves were entirely recorded by Mr. MacIver, from whose account the following are the more noticeable examples.

U 12 (s.d. 74), contained a pottery cist; bones of a man, carnelian beads, and double bird slate, inside it; pottery at south end outside.

The depth of some of these tombs is very unusual; U 36 (s.d. 55—68) is 10 feet deep; U 39 (s.d. 60) is 11 feet deep; U 44 (s.d. 41—68) is 10 feet.

U 67 (s.d. 65—75), an infant. Beads, long and disc blue glazed, in a string over head and round neck; and a bracelet of blue glazed coarse cruciform and star beads with shells.

U 74 (s.d. 78) was a plundered grave; but contained about the middle, on the floor, the copper axe, chisel and adze (see base of pl. vii.) which are the most important examples of the beginning of such tools (Cairo Museum); the half of a flint knife was loose in the filling.

U 96 (s.d. 36) contained all the bones stacked together as a tight oblong mass, wrapped in a reed mat as usual; the legs above the arms, no skull, scapulae, fingers, or toes. Two clay figures of men, coloured red, were in the filling (see pls. x., and base v.).

U 151 (s.d. 35—55), body closely contracted, lying on a basket-work tray of twigs $\frac{1}{4}$ -inch thick; short blocks of wood at top of head and back of sacrum. Disc mace head of diorite, therefore probably s.d. 35—40.

U 261 (s.d. 55—74), long bones dismembered and stacked parallel.

U 349 (s.d. 71) string of green glazed disc beads round the head.

U 354 (s.d. 70—80) had six flint bracelets on the left arm; necklace of tubular black steatite and ivory; many minute black beads all up the legs.

U 364 (s.d. 65—76), string of small black beads about hips; by head, a string of small green glazed and small white beads. Ivory cylinder inscribed (see pl. x., base), by right shoulder.

We have now summarized the methods that have been developed for working out the sequence of prehistoric Egypt, and the results of this systematic treatment of the remains. We have for the first time seen the whole prehistoric times of a country arranged in an exactly graded order and development. To have given more minute detail of the thousands of graves recorded would have overwhelmed the view without adding to its value. Every useful detail has been tabulated, and has thus helped to produce the general systematized view here given; probably further questions will arise, and further results be worked out from the notebooks of records. But for the present here is a connected view of each kind of remains, and of the whole historical result; and every conclusion is stated with such detail that all succeeding exploration of this period can be joined on to the present results, and be used to correct and supplement them. In future exploration every grave can be dated as it is opened, and the importance of any new results can be at once seen, and corresponding care taken to certify whatever facts will further extend our present knowledge.

CHAPTER IX.

TOMBS OF THE VITH TO XTH DYNASTIES.

55. In four cemeteries, D, N, W, and Y, tombs were found which may be safely dated before the XIIth Dynasty. The cemeteries D and W were worked by myself; N consisted of very few tombs, worked by Mr. MacIver; Y was a large cemetery worked by Mr. Mace, who will describe it himself in chapter xii. Broadly we are dealing here with all the graves which, though not assignable to the IVth or Vth Dynasties, yet belong distinctively to an earlier date than the well-known age of the XIIth Dynasty, with its many distinctive manufactures. In cemetery W there are 66 tombs belonging clearly to the XIIth Dynasty, and 40 of an earlier age, extending back to probably the VIth; a proportion which is not astonishing when we consider the relative wealth of the periods.

The plan of cemetery D is given on pl. xxiv., it is probably of the VIth Dynasty, and was all worked by myself. D 4 is a shallow pit, probably a plundered prehistoric grave. D 5 is a large mastaba; see separate plan below general plan. A rare form of cornice had crowned the doorway, representing roofing with round poles (see top pl. xxv.); now in British Museum. With it were fragments of two inscriptions, of the style of the VIth Dynasty, so well fixed at Denderah; one in relief, the other incised, naming the *amakhw kher Asar* ADY. The tomb front had six false doors on either side of the entrance; the whole floor of the entrance was a single block of limestone 103 × 46 × 6 inches; and traces on it showed that the passage was lined with blocks 10½ (or ½ cubit) thick, leaving a clear entrance of 27 inches. The central pit

at 10 feet down was filled with bones, mostly human, with some of ox, and an ass's skull. These continued from 10 to 20 feet down, to the level of the chamber top. The date of their burial was shown by a small plaque and a blue glass ear-ring of the XVIIIth Dynasty and pottery of the XVIIIth—XIXth Dynasty. All of the bones were separate, and only one spine was in line with the skull; yet between the bones was much brown earth from decomposed flesh, and the bones were by no means clean when buried. The skulls were equally male and female. Why dozens of human bodies should thus be cut up, and buried pell mell with those of animals, in an old tomb pit in the XVIIIth Dynasty, is quite inexplicable.

D 6 was a simple pit 10 feet deep, without a chamber; it contained at the bottom 11 gazelle heads without bodies, at 5 feet up a man's skeleton, and a foot higher a woman's skeleton.

D 7 had remains of a burial; model dishes in copper and two curious open work fans (?) of copper sheet and wire (see top pl. xxv., Philadelphia); evidently the same furniture as in the tomb of Meru (see *Denderah*, xxii.).

D 8 had the doorway leading southward to the chamber blocked with four rows of big stones, without mud. The body was laid full length, head N., face E.; on the neck, wrists, and ankles were five wires of copper with a few beads on them, and two copper armlets on the arms. Upon the jaws rested a pottery pan; and in front of the head was the large copper mirror shown in pl. xxxi. A jar was in the N.W. corner of the chamber.

D 9 had been opened, and only contained

some small blue beads on the neck, and one jar in N.E. corner.

D 10 contained three pots along with the skeleton in the chamber.

D 12 was apparently a later (? Roman) burial of a dried body, in a shallow grave with side recess.

D 13 was 18 feet deep; chamber to S. closed with stones; body of man full length, head N., face E. One copper needle lay by the collar bone. A jar in N.E. corner.

D 14, similar tomb and position, a woman of about 23 years. A large mirror before the head (see top pl. xxxi.); four small stone vases in front of the body (see pl. xxviii.), one pointed vase of limestone, a dish of diorite, and two vases of alabaster (compare *Dendereh* xxi., mid top). About the neck, beads of green glaze and carnelian; note on the bottom string the two leg amulets and hand, of carnelian; and next above that the very degraded form of the prehistoric bull's head amulet, along with the later forms of dynastic bulls' heads.

D 15 had a walled-up recess on the west, with body, head N., and some carnelian and small green beads on neck (Liverpool).

D 16 was opened anciently and broken up; one pot left.

D 21, pit about 13 feet deep, no chamber; at 12 feet down an ox body and head, at 8 feet down two dog and six gazelle heads, at 7 feet down a female burial with a scarab of Ramessu I.

D 24 had a disturbed burial, with beads of XVIIIth Dynasty, halfway down.

D 25, a large mastaba, much ruined; about it were found a drum lintel with name *heq hat UHA*, a scrap of another lintel with *BEBA*, and a piece of good relief inscription, all evidently of VIth Dynasty. In the filling of the chamber were four skulls (one male, three female) high up, mixed with Old Kingdom pottery, but no other bones. We can sum up this cemetery as clearly of VIth Dynasty, by the inscriptions of the two

large mastabas, by the copper models and by the stone vases already shown to be VIth at *Dendereh*. We have thus a good fixed point for the beads and amulets in D 14. At the N.W. of each mastaba is a pit (D 7, D 21) with heads of gazelles, &c., evidently a part of the funeral sacrifices. At Medum are small offering pits, but in the body of the mastaba, and S.W. of the tomb (*Medum*, p. 20, 21); at *Dendereh* the well for offerings of prince Mena is to the W. of the tomb pit. The human burials higher up in pit 6 are probably secondary, as that in pit 21 is certainly of XIXth Dynasty. Examples of all of the animal bones were sent to the Natural History Museum, South Kensington.

56. In cemetery N the only tomb which need be noted here is N 19, recorded by Mr. MacIver, a well with chamber to the S., containing the body of a young girl, head N., face E.; the legs bent square at hips and knees. Before the hands was the copper mirror on pl. xxxi., with inscription of the royal noble, priestess of Hathor, *BEET-THA*: and before that were four small pointed vases of alabaster, see top of pl. xxviii. Around the head was a necklace of several strings of limestone beads, covered with gold foil, carnelian amulets, eye, and jackal's head, Horus of green felspar and blue glazed beads; tortoise-shell bracelets on arms. Traces of a stuccoed wood coffin around the body (Philadelphia). This burial, from the forms of the vases, is clearly of the VIth Dynasty.

57. The cemetery W is the large and important cemetery of Hu at the end of the dyke, worked by myself, and Y is another portion of the same further north, worked by Mr. Mace. We here select those graves of W which are earlier than the XIIth Dynasty.

After seeing above the characteristic forms of the stone vases of the VIth Dynasty, small, pointed, with a concave collar neck (see pl. xxxviii., N 19 and D 14), the similar and rather clumsier forms in other graves may be assigned

to the VIth and VIIth Dynasties. Such are on pl. xxviii., the group W 83 (twice in plate, Aberdeen), the group W 100, and the vase W 177: all of these are so closely of the VIth Dynasty forms that they must be almost of that age. Now with these forms were the pottery W 83, pl. xxv., which is also clearly of this age, by comparison with the Denderah pottery; the button, W 90, pl. xxv., agreeing with the VIth Dynasty date of a button at Denderah; the mirror (pl. xxxi.), button, and beads, W 100 (pl. xxviii.), placed with a long burial in a box coffin with a string of small gold beads round neck, a string of white shell beads down the front, and a mass of blue and black glazed disc beads at the waist (at Manchester), and this dates these long lines of such beads in other graves; and in W 177 (at Melbourne) was a string of black disc beads, and a scarab with a rabbit (see pl. xxviii.). These beads then take W 163 (at Aberdeen) to the same date, a full length body in a coffin, buried only two feet down. And like this is also W 165 with the pyramidal geometric figure seal (pl. xxv.). Associated with 177, in the same small group of similar graves, were W 173, 174, shallow brick graves, two feet deep, and W 175 (Chicago), 176, with hemi-cylindrical seals, shown in pls. xxv. and xli. 1, 2, 3. These seals belong to the same class as the geometrical patterns of buttons of this age, which are derived from figures of men and animals.

Hence we find as characteristic of the VI—VIIIth Dynasties, pointed alabasters of good forms, growing clumsy in the later cases, buttons and hemi-cylinders with geometrical patterns, long strings of black and blue glazed disc beads, carnelian amulets of bull's head, hand, and leg.

Judging by the forms of the alabaster vases, the group W 157 (pl. xxix.) must be rather later than those we have noted, and so about the Xth Dynasty; with these were beads of carnelian, black and blue glaze. The clumsy

forms of the two kohl pots, W 98, pl. xxviii., seems to point to their being also about the Xth Dynasty. Next to these are the vases X 59 (from close to W cemetery) which are clearly of the same age, or perhaps as early as the VIIth—VIIIth Dynasties; with them were minute gold beads and pendants, disc shell beads, small blue glazed beads, a long string of black glaze and shell beads all up the body, and some carnelian beads and amulets: the kohl pot next to the shell (xxviii. left side, third line) is of dark blue glaze (University College, London).

58. The burials of the same period in cemetery Y are described by Mr. Mace, as follows:—

“In cemetery Y we have a series of tombs running right through from the VIth to the XVIIIth Dynasty. These may be divided into four classes—

“*a.* Shallow graves, VIth—VIIth Dynasty.

“*b.* Pit-tombs, VIth—XIth Dynasty.

“*c.* “ “ , XIth—XIIth Dynasty.

“*d.* YS shallow graves, XIIth—XVIIIth Dynasty.

“The graves of the class (*a*) were situated on the edge of the valley which separates the W and Y cemeteries (see plan). The graves were small, but two to three feet deep, and, in the majority of cases, they faced north. The bodies, which had originally been enclosed in coffins of plain wood, or wood stuccoed, lay for the most part with head north, facing east, legs slightly bent, left arm by side, right laid across body. In some cases, however, the hands met before the face, while the legs were bent back from the knee so sharply that the feet rested against the pelvis. A few instances seem to point to a partial cutting up of the body before burial, e.g.:—

“110. Two skeletons: upper part of both undisturbed, leg bones more or less scattered, but with two of the femora laid approximately in position with the ilia, the ball of one being turned directly away from the socket.

“127. Burial beneath an inverted pottery

coffin: upper part of body intact, but head turned the wrong way: lower bones out of position.

"134. Two skeletons: (α) skull turned round so that the vault rested against the upper vertebræ, both scapulæ lying close together near the pelvis: other bones in position. (β) Arm bones disarranged, pelvis in position, leg bones lying all together, ribs piled neatly in a heap unbroken, skull, with lower jaw attached, resting on pelvis.

"These must have been the graves of the very poorest of the people, none of them containing more than a pot or two, and a few beads and amulets. The pottery consisted of flat dishes of the well-known VIth Dynasty form, and vases of the type xxxiii. 6. Among the beads were small blue and black glazed disc, shell disc, blue glazed cylinder, flattened crumb, and large barrel-shaped carnelian. Grave 103 had a necklace of glazed amulets, including hawk and bulls' heads, frogs, and fishes; 104 contained glazed teeth amulets and an ivory drop pendant; 110, an ivory button (pl. xxv.).

(b) Among the pit-tombs there are several which may be put down pretty definitely as pre-XIth Dynasty. Tombs 6, 8, and 9 are the earliest, probably VIth—VIIth: all three face north, and have their chambers opening from the side of the pit and not from the end; 6 contained a small alabaster (Boston); 8, a bronze mirror, an ivory spoon, and three alabasters (Melbourne); 9, a small diorite vase (Boston). For this last, and the alabasters, see plate xxviii. The alabaster, 16, from the same group in plate xxviii., belongs, from its shape, to this period, but the tomb contained also a headless stone statuette giving the name *Ren-senb*, which could hardly occur so early. The tomb was plundered, so the alabaster may belong to an earlier burial.

"Several of the pits seem to have been used as regular family vaults. For example, 73 ran east and west, and had a chamber opening from

each end: in the west chamber were eight burials, three men, three women, a baby, and a young child, all in normal position; in the east, three burials, (α) a man in normal position, (β) a woman in contracted position with a tiny baby by her side, (γ) a man, contracted. The skulls of the two last (β and γ) show a decided tendency to prognathism; this, taken in conjunction with the position of the body, suggests that they belong to the old pre-dynastic race, which had not yet become entirely merged into the dynastic. We have another example of this in 63: the west chamber contained one skeleton in normal position; the east, which was carefully bricked up, contained one skeleton in normal position, and *beneath* it two others sharply contracted, possibly servants sacrificed at the funeral. In the filling of pit 56 (E.—W.) there were four skeletons, and several pots of VIth—XIth Dynasty type; both chambers at the bottom were bricked up; the west contained the skeleton of a man, the east those of two women, one with a necklace of small glazed beads; all three skeletons were originally enclosed in stuccoed wooden coffins.

"Among other tombs of this period we may note the following:—35 (E.—W.), skeleton of a woman; by the head a small gold hawk with double crown (xxv.); round the neck several strings of small carnelian beads, one having a centre of four large carnelians and a glazed scarab; round the body strings of small carnelian beads, and small glazed beads with occasional large carnelians; lower down a string of large green glazed beads; on the left arm were two bracelets, one of tiny carnelians, the other of small gold beads and glazed amulets; in front of the face was a small alabaster (xxix.), and on the north side of the chamber was a large shell containing kohl, and a pot of the type xxxiii. 14 (Chicago). Pit 90 (E.—W.), bricked up chamber to W.; skeleton of a woman, position normal, head W.; behind the head a fine pointed alabaster vase (xxviii.); by the neck two long

glazed cylinder beads; round the waist a girdle of beadwork some ten inches broad, consisting of rows of blue and black glaze and shell strung together irregularly, with an outer fringe of common shells (Boston). These rows of beads had been sewn on to some material, possibly leather, but this had been completely rotted away by the damp. 92 (E.—W.), chamber to W.; skeleton of a woman, head W., position normal, but head disturbed by plunderers; seven of the vertebræ joined in one place; two necklaces, one of small gold beads with a gold frog amulet, the other of tiny blue glaze; behind the head a limestone jar (xxviii.), and a bronze mirror (xxxi.); before the face a pot of type xxxiii. 14 (Manchester).

“To this period also must be assigned the

carnelian and gold Hathor amulet (61) on plate xxv. (British Museum); the hemi-cylinder (78) on plate xli. (Philadelphia); the bronze axe with handle (162) on plate xxxii. (Philadelphia); the alabasters and granite mortar (182) on plate xxviii.; and the alabaster vases of 250 on plate xxviii. (Ashmolean).”

59. Apparently to the earlier part of the XIth Dynasty must be ascribed the only two steles found in the whole cemetery (pl. xxv.), those of NEKHTYK, and of HOTEPAQERA with his two wives, Khut and Apu. The title *mautkheru* on both steles points to their not being before the XIth Dynasty (*Denderah*, p. 51.), and the style and names prevent our dating them in the XIIth or any later age. Nothing noticeable was found with either of them.

CHAPTER X.

TOMBS OF THE XIITH DYNASTY.

60. It will be best in dealing with this period to state first what we have found to be characteristic of this time.

1. *Pale blue marble* of fine grain, very commonly used for kohl pots; in no case has this yet been found fixed to any period either before or after the XIIth Dynasty. At Denderah nearly all of the tombs were before the XIIth Dynasty, and not a single piece of blue marble was found in any such; one or two tombs were fixed to XIIth Dynasty by scarabs and different style of objects, and only in these was blue marble found. Not a single piece occurs in W or Y cemeteries with objects before the XIIth Dynasty. The earliest dated example is of Usertesen I. (Brit. Mus.). Nor has this marble ever been found with objects later than XIIth, except in a few cases of mixed tombs, with XIIth and XVIIIth objects together.

2. *Amethyst beads* were in no case associated in W or Y with objects that could be dated either before or after the XIIth Dynasty. A few are known in prehistoric times, and occasionally an amulet, a scarab, or a bead may be of the Old Kingdom or XVIIIth Dynasties; but no string of amethyst beads is known outside of the XIIth Dynasty, until the very different style of the Roman times.

3. *Ball beads* of glaze, amethyst, carnelian, &c., are peculiar to the XIIth when of large size; and even small sizes are but seldom found of the regularity and polish of those of the XIIth Dynasty, and then only of carnelian. The large brilliantly glazed balls and amethysts, up to half-inch diameter, are absolutely characteristic. Sometimes they have gold or silver

caps at the ends, or tubes through them. Rhombic flat centre beads of carnelian are all of XIIth Dynasty, so far as known.

4. *In alabaster*, round-bottomed vases and short cups with straight conical sides are in every dateable case entirely of the XIIth Dynasty.

5. *In copper work*, axes very shallow, symmetrical, to fix in a stick with but slight projection, are of Vth Dynasty; rather deeper in VIIIth; full semi-circle or rather more in XIth, but flat on sides; with fat convex sides and incurved edges in XIIth; thin, long, but symmetrical, in XIVth (Suazenra); unsymmetrical, back sloped, in XV—XVIIIth Dynasty.

Daggers are quadrangular with curved sides in prehistoric times; have fluted ribs down the middle in the XIth Dynasty, and in XIIth (?); no fluting, only a broad slight band on middle in XIVth and on to XVIIIth.

61. We now describe such of the tombs of the XIIth Dynasty as are notable for completeness of information. These tombs usually comprise an oblong pit about 8 ft. × 3 ft., descending 10 to 20 ft.; with a chamber opening out of one end, or sometimes one at each end, or even two or three superposed at one or at both ends.

The direction of the tombs is first to be noticed. At Denderah the tombs

Of VIth and VIIth Dynasty, are N.—S.;

Of IXth—XIth Dynasty, are E.—W.

On tabulating the present tombs, we find that those with the hemi-cylinders of geometrical patterns, which we attributed

To about VIIth Dynasty, are N.—S.

Other tombs with black and blue disc beads, pointed alabasters, and pottery, assigned to the Xth Dynasty, attributed so far to the

VIth—Xth Dynasty, are E.—W.

Further, another large class with pottery attributed to the XIth and XIIth Dynasties, small dark blue ring beads, black beads, carnelian rhomb, a scarab, and an engraved shell, both of Usertesen I., and in *one* case small ball beads of carnelian and amethyst of XIIth Dynasty style, in short,

XIth Dynasty to Usertesen I., are E.—W.

But all tombs with ball beads of blue glaze and amethyst, serpentine figures, blue marble, and globular vases, in short,

Usual XIIth Dynasty, are N.—S.

The summary therefore is that the direction of the tomb was in

VIth to VIIth Dynasty, N.—S. ;

VIIIth—XIth and to Usertesen I., E.—W.
(and perhaps earlier).

Usertesen I. and XIIth, N.—S.

Of beads the black and blue disc are VIIth—Xth; the small blue rings probably XIth (as at Denderah); and the ball beads of glaze, and amethyst, and the blue marble—the characteristics of XIIth Dynasty—begin about Usertesen I.

62. Of the pre-Usertesen tombs lying E.—W. may be noted,—

W 65, containing the ribbed copper dagger, pl. xxxii. 4; with some jars of globular form, pl. xxxiii. 16 (Chicago).

W 70, with the curious tray of offerings, or “soul house,” in pottery, pl. xxv. base. The tank by the side of the hut, with holes for sticks to support an awning is new to us (Pitt Rivers Mus., Oxford).

W 84 had copper models of chisel, adze, saw and axe (pl. xxxii. 5 to 8) lying on the floor of the pit, with one jar, pl. xxxiii. 15 (New York).

63. Of the XIIth Dynasty tombs lying N.—S. may be noted,

W 29, in the corner of the north chamber was a group of two statuettes in black serpentine, on a limestone base with steps (see pl. xxvi., top). Around the base is written in ink, *suten hotep du en ka Asar Sent* (Cairo Museum).

W 32 was a fine untouched tomb of a girl, lying full length, head to north. The small objects are shown in pl. xxvii., top; the mirror in pl. xxxi., the alabasters in pl. xxix. Immediately inside the blocking of the door were four pottery pans, one still containing dates, and on the east side of the coffin were fifteen more pans and jars of the type xxxiii. 22: in some of these pans were dates, birds' bones, and leaves. Also the blade-bone and hoof of an ox. In the wooden coffin was the alabaster kohl pot and lid above the head; two fishes, one gold, one silver, on the crown of the head; the copper mirror was in front of the body. The globular vase of blue marble lay on the middle of the shins. The tubular carnelian beads were at long intervals between the amethyst balls; the ball carnelians had the silver hawk pendant as a middle piece. On the right wrist were three fine amethyst scarabs. The whole burial is now arranged complete in Philadelphia, as there is no museum in England that can take in such entire tombs.

W 38 was a rich tomb, though entirely turned over by plunderers. The small objects are shown in pl. xxvii.; in the middle of the top line a fish of green felspar with electrum fins, an ivory kohl stick, and a wire with beads of coloured stones (imitation amulet case) on either side: below, one of the spout dishes of alabaster, like two others in pl. xxx., top; such seem to belong to the XIIth Dynasty. A dark brown serpentine ushabti, pl. xxvi. (at Cambridge), some big jars, slightly longer than xxxiii. 22, and blue ball beads, were in other chambers of this tomb.

W 72 was probably the richest tomb of all, for the number of burials. It had been com-

pletely turned over by plunderers, and filled with earth washed in; so that it occupied about two weeks to entirely clear it. In it was the ivory doll with silver wire earrings, pottery doll, pottery ass with packs, and a great quantity of beads, of which a sample is shown with the figures in pl. xxvi. Four alabasters and a pottery bowl from this are shown in pl. xxix. Beside these there were haematite beads, many strings of large and small ball beads and fluted ball beads (Cambridge).

W 161 was an unusual burial of objects in an open pit, without any chamber, see base of pl. xxix. At the top is a fish vase of alabaster; a blue glazed hedgehog; and a copper wire ring. Below, a lipless vase of alabaster, a kohl pot, and parts of a dish (Philadelphia).

64. Mr. Mace will next deal with the tombs of the XIIth Dynasty found in cemetery Y:—

“As regards direction of pits cemetery Y supports very fairly the conclusions which have been drawn from W, i.e.—

“VI.—VII., N.—S.;

“VII.—XI., E.—W.;

“XII., N.—S.

There are, however, a few instances which show that the eastward direction was not entirely unknown in the XIIth, perhaps later than Usertesen I., to which it is assigned above. For example, pits 15, 34, and 96 contained glazed ball beads; 51 contained amethyst beads and a specimen of blue marble; 66 a blue marble kohl pot: all these ran east and west. In almost every instance the burials of this period had been plundered; we note two or three of the more important. 15 lay E.—W. with a chamber at each end; the west chamber had been completely plundered out; the east, which was bricked up, contained an untouched burial. The skeleton had originally been enclosed in a painted and stuccoed wooden coffin, and from

the remains of the top band of inscription one could just distinguish the name of ‘the priest Abmu’: round the neck there were two strings of beads, one of alternate large glazed ball and small glazed cylinder, the other of small glazed ball (British Museum). Scattered in the pit of 51 (E.—W.) were found the group of vases on pl. xxix. (top right), consisting of four alabaster kohl pots, one blue marble kohl pot, a slender alabaster vase, a small limestone jar and a broken alabaster saucer; also a bronze mirror, an amethyst scarab, a green jasper scarab, two gold fly amulets, and some fine carnelian and amethyst beads (Pittsburgh). 91 (N.—S.) had been a rich tomb, but had not escaped the plunderer: it contained an alabaster vase and two bronze mirrors (xxix.), a quantity of very fine amethyst, carnelian and garnet beads, two amethyst scarabs, two glazed scarabs, three small bird amulets in serpentine, and a large hawk amulet in silver-plated pottery (Manchester). No. 6 (E.—W.) of cemetery G (further north) was an open grave, about four feet deep, containing the skeleton of a young girl (head west): the skull and upper part of the body were disturbed, but the arms and lower part were in position; on the right wrist there were two bead bracelets, one of tiny green glaze, the other of carnelian, haematite and white felspar; round the elbow a string of haematite beads, with two amethysts and one carnelian; on the left arm a bracelet of carnelian, haematite and white felspar, and round the body a string of the same three stones (New York). Other objects from the pit tombs of this period noted in the plates are—the scarab of Dad-uah-an-neferka (66), in pl. xxv. and xli.; the alabasters of 152 and 189, in pl. xxix.; the bronze tweezers and knife (176), in pl. xxix. and xxx., and the blue marble of 66 and the alabasters of 4, 5, 34 and 75, in pl. xxx.”

CHAPTER XI.

THE PAN GRAVES.

65. While working at Abadiyeh Mr. Mace found a grave (E 2) which puzzled us greatly; the known pottery of it was clearly of the XIIth—XIIIth Dynasty style, but with that were several cups of black topped red pottery: the fabric of these latter being like the prehistoric, while the forms were new to us. The whole of the contents are shown by photographs in pl. xxxviii.

Again in the top edge of cemetery B, I found several shallow little graves, all plundered; but containing scraps of black topped pottery, and many slips of shell, which we afterwards knew to belong to bracelets. But we could not find any evidence of the age of these pits.

During my work at Hu I found a small cemetery (X) with a similar mixture of pottery, and I cleared over fifty deposits of this age; but by no means all graves, as twenty-two deposits were placed apart from any bones. Briefly the characteristics of this class are:—shallow pan-shaped graves, bracelets of shell strips threaded together, groups of animal heads prepared to hang on a wall, and a mixture of black topped pottery with late pottery and worn-out stone vases of the Middle Kingdom. The period must evidently be after the XIIth Dynasty. We now describe the details of these deposits:—

66. *The Graves.*—These are usually circular or oval, about 30 to 40 inches across, and sunk about 10 to 15 inches in the hard marl, above which lay about 10 inches of loose dust. The positions of the graves, and of the separate

deposits in the dust, are quite irregular, and it is needful to turn over every inch of the soil of such a cemetery in order to avoid missing any deposits.

The Bodies.—In only nine cases was the position of the body ascertained (12, 16, 17, 27, 38, 39, 63, 66, 74), as the others had been cut up or plundered; all of these lay on the right side, head or top of body to W.; face or front of body to S. The hips slightly bent, or at right angles; the knees sharply bent, with feet below or behind the body. This direction differs from that of all other periods known to us.

But there are several evidences that the body was often more or less cut up, though many graves have been disturbed by plunderers. In X 17 the bones were wrapped in cloth and sheepskin, and the sacrum had been parted from the iliac bones. In X 38 the head of the child was missing, the spine was complete, and the top vertebra was close against the side of the grave, without any room for the skull. In 39 the head of the old woman was removed, and lay on the chest, with the top vertebræ attached; only 18 vertebræ of the spine remained. In 24 were strings of beads wound round the clavicle, and on the upper ends of the humerus and femur; and the bones were all dis severed and mixed up completely with bones of an ox and sheep. In 32 was a string of beads around the humerus, but the grave had been plundered. In 26 the ribs were together, under and through the loose jaw; the long bones and vertebræ scattered. In 25 the bones

were loosely piled together, a foot high. Though some of these conditions might be due to plundering, yet the top of the spine against the wall, and the beads wound round the bones, could not be supposed to be other than original arrangements.

In one case woolly brown hair was scattered in the grave.

67. *The Animal Heads.*—In one case a grave, and in ten cases separate pits, containing animal skulls were found. All of these skulls were cut away at the back, so as to only leave the frontal bones and enough to hold the horns in place, see pl. xxxix. All, or nearly all, were painted with spots or stripes, of red ochre and black soot, laid on with the finger. They were clearly intended to hang up on a wall. Only once was an ox head found entire, with the jaws. The largest deposit was in X 57, containing 138 goat heads, 5 of oxen, 5 of calves, and 1 sheep's head; these were all stacked in rows, leaning one on the other, noses to W., horns to E., in an area about 70 inches E.—W., 40 inches N.—S. A pair of copper tweezers was with them.

In 61 was a row of goats' heads stacked against each other, leaning against a jar and cup, facing eastwards. In 62 a similar row leaning against a jar, facing S.E.: one head had blue beads with it. In 72 a similar row of goat heads facing S.W., a bowl inverted over them.

Smaller groups were in X 23, 5 goat and 2 ox heads; in 47, 3 goat and 3 sheep heads, heaped on E. and S. of a jar; in 49, head of a young calf, 2 gazelles, 5 goats, a kid, and 2 sheep, with a cup and a grinding stone; in 65 were heads of an ox, 8 goats, and 2 sheep, with alabaster jar, 2 rubber stones, basket, beads, &c.; in 67, heads of an ox, a calf, 9 goats, and a sheep, with a worn kohl pot, rubber, and bowl; in 71 were 2 ox heads, a calf, a sheep, and some goat heads, with a jar. The numbers of heads in these deposits, there-

fore, varies much; but there are always half-a-dozen or more, and usually one or two ox heads with those of lesser animals. These regular stacks of heads never occur in a grave, but always as a separate deposit.

68. *Of Dress* there are sometimes goat-skins; in X 68, some coarse linen cloth, and also matting below the body; in 29, a leather sandal.

Ornaments of shell and beads are abundant. The characteristic decoration is the wearing of three shell bracelets on each forearm. These bracelets are made of slips of shell (see base of pl. xl.), threaded together through each end; two threads of sinew were passed through each hole, crossing, and one passing along each side; this is an efficient way of making a flexible band for a bracelet, as seen in the strips photographed, which are re-threaded in the ancient manner. The slips are usually each about .8 to .9 inches long; the number in a bracelet is 18 and 21 in the photograph (X 29), and in other cases lengths of 12, 16, 17, 18, 21, 24, 35, and 38 slips have been found. Large numbers of these slips were found a few years ago by natives, and sold in long strings by the Luxor dealers, with beads between them; but the original disposition of the slips was always edge to edge, with a double thread crossing in the holes, in every case that I found.

The beads that may be attributed to these people are of white shell, and small rings of black or blue glaze; but with them are stray beads of the usual XIIth Dynasty style, in garnet, gold, and blue glazed balls. Beads are usually in long strings, sometimes all of one colour, black, blue, or white; sometimes in short lengths, 7 white and 7 black alternate; usually 1 white alternating with 2 or 3 blue or black. One body that had 3 slip bracelets on each arm, had also on each ankle 3 strings of black and white beads alternate.

Other beadwork is found, both on interwoven threads and also stitched on to a basis of leather,

In 68 were shell beads threaded in four parallel lines. In 65 was a band of parallel columns of shell-beads, each 7 beads long, like a usual Egyptian bead anklet. In 31 were lines of shell-beads edge to edge, sewn on leather, the lines .8 inch apart. In 29 were lines of 4 shell-beads each in parallel columns, sewn diagonally on a leather band; and also of the same pattern without a backing, but with a twisted sinew edging. In 50 was leather sewn together, with shell-beads put into the seam as a piping.

69. *Of Utensils* there was very little in copper, only a knife with wooden handle in E 2 (pl. xxxviii., top), and simple tweezers in X 57 and 71, evidently old XIIth Dynasty articles descended. Baskets were found in 58, 65, and 74, the latter about 8 by 6 inches. Grinder stones of sandstone, of small size, are found in five graves; in two cases a pair together. No mace-heads or worked flints were found, not even any flakes.

Of minor things may be noted a mud brick in grave 25, which might, however, have been taken from a XIIth Dynasty tomb, as a ring-stand of that age was with it. Some malachite in a cloth was in grave 24, showing that it was used as by the prehistoric people; and in a jar of Egyptian form in grave 21 (see base of pl. xxxix.) were about fifty of the common black desert beetle, like the burials of beetles in jars in the prehistoric tombs.

70. *The XIIth Dynasty Objects* are the materials for dating these graves. The kohl vases, &c., were nearly all broken, damaged, or worn, showing that they were old ones re-used; the pottery was never of the thin, drab, globular type which led from the XIth into the XIIth Dynasty, but mostly of the late XIIth Dynasty forms, leading on to the early XVIIIth Dynasty. The XIIth Dynasty Egyptian objects figured here are in pl. xl.; in group 36, on the left two broken kohl pots of black and white limestone and brown limestone, on the right a blue

marble pot; these were found with the two black and red bowls, a large black bowl (top mid. of plate) full of ointment, and a sandstone rubber, all in a small group together. In 78, a broken kohl pot. In 46, a broken kohl pot of alabaster, and a blue glazed ring-stand (below it in plate). In 33, broken alabaster vase. In 65, a globular alabaster vase, broken. In 43, a broken and a perfect alabaster kohl pot and the bottom of a large vase of brown serpentine. In 70, a small black basalt vase. In 74, a small perfect kohl pot and lid.

Of the pottery a selection is here photographed, omitting duplicate examples or small variations. Several of the forms on pl. xxxviii. and all the jars on plate xxxix. are clearly of Egyptian make, and intermediate between the XIIth and XVIIIth Dynasty styles; on the whole nearer those of the latter than of the former date. The small ring-stands on pl. xl., groups 7, 8, 25, 46, are also clearly Egyptian.

71. *The Pan-grave Pottery.*—But besides the Egyptian pottery there is also a class of bowls which is entirely different. These are mainly shown on pl. xl. The largest are always thick and black, patterned with a band of diagonal lines round the upper part, and sometimes (as in X 25) a square of incised pattern on the bottom, showing that they were inverted when empty. These large bowls, as well as the Egyptian jars in these deposits, were usually filled with ointment, or aromatic fat, so usual in the prehistoric time, and found also in the XVIIIth Dynasty. Smaller bowls were usually thinner, and with a narrow brim of ornament, as in graves 17, 16; the finest and most decorated of this form has basket pattern incised all over the outside (see group 36). Most of the rest of the pottery is of simpler or rougher work on these forms. But in E 2 (pl. xxxviii.) there is a finer class, red with black top, as the prehistoric pottery, but of hard ware and very thin and light (see top group); and the form gracefully turned out

at the lip. The coarse black pottery with diagonal incised lines had been found before at Kahun, at Ballas, and at Nubt, in each case assignable to the XIIth Dynasty, and therefore it does not belong to any merely local class, but was general at its own period.

72. *The Black Incised Pottery*.—Beside the barbaric pottery proper to these pan graves, there are also some pieces of a refined and beautiful class which descends from the incised pottery of the prehistoric times. This black pottery, with pricked patterns filled in with white, begins as early as s.d. 33, and is found down to s.d. 68; it appears to be a foreign importation. Following that is the incised bowl of about the Ist Dynasty, found at Abydos; the incised bowls of the IIIrd Dynasty (*Denderah*, xxi.; and from Dahshur, De Morgan, *Recherches*, i., pl. xi.); and then the narrow-necked vases found at Kahun (*Kahun*, xxvii. 199—202; *Illahun*, i. 17, 20, 21), at Khataaneh, and at Tell el Yehudiyeh, all attributed to the XIIth or XIIIth Dynasties. In pl. xl. is seen a perfect vase of this type, grave 41, but of red pottery and not incised; and below that, group 43, are pieces of vases of the same form, but of black ware, and with the typical vandyke patterns filled in with pricked spots. This whole class is entirely un-Egyptian, and due to foreign importation.

73. *The Dogs' Graves* found here are also un-Egyptian; two instances were found of circular graves filled solely with dogs' bodies; in another, an existing VIth—XIIth Dynasty full-length bricked grave, about 6 feet deep, had been emptied, and a layer of dogs' skulls and bones were put in the bottom foot depth. This is like the grave with about twenty dogs' bodies found in cemetery T at Naqada (*Naqada*, 26, see No. 286).

74. *The Age and Source* of the pan-grave people is now tolerably clear. The abundance of worn-out objects of the XIIth Dynasty, and

the pottery intermediate between the XIIth and XVIIIth Dynasties, shows that these people must have come into Egypt after the fall of the Middle Kingdom. The presence of their pottery at Kahun and Nubt, already dated to about the XIIth Dynasty, shows the same age, and proves that they were spread over the western edge of the desert for some 250 miles. They were a barbaric people, not working either stone or metal, and dependent on the Egyptians for everything except pottery. They were closely akin, however, to the prehistoric Egyptians, as is shown by—

1. The pan-graves, like the earliest prehistoric;
2. Red and black pottery, as early prehistoric;
3. The burial of malachite;
4. Beetles buried in jars;
5. Bucrania on buildings;
6. Burial of dogs in cemeteries;
7. Burial of jars of ointment;

and in all of these points, except the last, there is no connection with the later Egyptians of historic times. We therefore conclude that these people were a later branch of that same Libyan race which had formed the prehistoric population of Egypt.

The bucrania, or skulls of oxen, goats, &c., prepared and painted to hang on the walls, are decidedly western. In the age of Narmer, just before Mena, they are shown on an ivory carving as being actually hung over the doors of a building (see *Hierakonpolis*, i., pl. xiv.); and in chapter vi. of this volume are mentioned the various instances of the use of the bull's head, which belongs particularly to Libya and southern Europe.

The museums where this class of pan-grave remains can be seen are here stated, with the reference numbers of the deposits presented to each, all from cemetery X, unless otherwise stated.

British Museum . . . 17, 41.

Ashmolean, Oxford	E 2; X 11, 16, 24, 25, 26, 36, 41, 43, 46, 47, 69; W 10, 58, 80, 102.	Brussels	11, 48, 63.
Cambridge, Ethnological	1, 2, 9, 21, 67, 68, 70.	Melbourne	32, 58, 61, 78, 79; Y 417.
Univ. Coll., London	8, 25.	Sydney	11, 13, 58, 73.
Owen's Coll., Manchester	7, 22, 28, 67.	Philadelphia	2, 21, 30, 57, 58; W 101, 164; Y 300.
Liverpool	38, 65, 74.	Chicago	29, 33, 42, 49, 51, 70, 76; Y 490.
Bolton	50, 65, 77, 80.	Connecticut	1, 52, 58, 62, 63.
Edinburgh	10, 23, 58, 64.		

CHAPTER XII.

THE TOMBS OF THE XIIITH TO XVIIITH DYNASTIES.

BY A. C. MACE.

75. The YS (shallow) cemetery, worked by Mr. Randall-MacIver and myself, lay immediately south of the Y pits, and extended right up to the modern Coptic cemetery (see plan). The first few graves cleared were poor and badly plundered, and seemed to contain merely a mixture of XIIth and XVIIIth Dynasties pottery. As we went on, however, we were forced to the conclusion that the contents of each tomb must belong to a single burial; and therefore, that the cemetery, containing as it did remains which presented characteristics of both XIIth and XVIIIth Dynasties, must be put down as intermediate between those two Dynasties. We noted the contents of some three hundred graves, and in none of these, if we except a few Roman skeletons, buried a foot or two below the surface, was there any later re-burial. Where there were two skeletons in one grave, which occurred only three or four times, both were clearly of the same age. The majority of the graves were plundered, and as the surface of the desert was absolutely level, and gave no indication of burials beneath, this plundering must have taken place anciently. In two or three cases we found plunderers' scrapers, made from XVIIIth Dynasty painted pottery, and therefore it was in this Dynasty in all probability that the plundering took place; plundering due in part, it may be, to racial hatred, since the occupants of the YS cemetery were closely connected with the foreign "Pan-grave" people.

In the following three sections we give the chief characteristics in each case, which show

the connection between the objects found in these tombs and the well-known types of XIIth and XVIIIth Dynasties, and "Pan-graves" respectively.

76. *Connections with XIIIth.*—Of scarabs with XIIth Dynasty names we found four—one very fine gold-plated one in amethyst of Usertesen I. (xli. 7, Philadelphia), one in glaze of the same king (xli. 8, Chicago), and two in glaze of Amenemhat III. (xli. 9 and 10, Cambridge). This proves that the graves containing these scarabs are not pre-XIIth Dynasty, but does not necessarily imply that they are definitely XIIth Dynasty; scarabs, especially fine ones, would be very likely to be handed down for two or three generations.

The pottery connections are striking; of the VIth—XIth Dynasties style, which we know so well from Denderah, there was but one example (150) in the whole cemetery. Real XIIth Dynasty types, however, are common; many of the dishes on pl. xxxv., notably 92, 104, 109, 119, 123, and of the vases in pl. xxxvi., e.g. 140, 142, 153, 166, and 169 are of well-known XIIth Dynasty shape. No. 169, which is one of the commonest of XIIth Dynasty pots, had, in two examples, the characteristic XVIIIth Dynasty whitening of the rim. Twelfth Dynasty "wavy" and "scrabble" patterns we find in 103, 112, 118, 119, 142, 153, and 179. The ring-stands show a tendency to lose their XIIth Dynasty symmetry, and adopt the XVIIIth thickening of the base. Two or three examples of soul-houses occur.

Another connecting link with the XIIth

Dynasty is found in the presence of blue marble and amethyst: these occur but rarely, and were evidently going out of use. The blue marble kohl pots were generally old and chipped, and in two or three cases they had had alabaster lids fitted to them: the amethyst beads were of the ordinary small globular type.

77. *Connections with XVIIIth Dynasty.*—That the cemetery must be assigned to a period not very long before the XVIIIth Dynasty is evident from the shape of the bronze axe-heads and ivory wands (see pl. xxvii. and xxxii.). Both are of well-known XVIIIth Dynasty style (e.g. the wand of Aahmes, and the axe-heads of Kames and Aah-hetep in the Cairo Museum), and need not be dwelt on further here.

The pottery is almost as conclusive: 110, 125, 130, 136, 173, and 175 on pl. xxxv. and xxxvi. are regular XVIIIth Dynasty shapes. Several, moreover, were smeared with white paint on the rim and inside, a practice which was common enough in XVIIIth, but, so far as we know, unknown in XIIth Dynasty.

78. *Connections with "Pan-graves."*—Though the graves of this cemetery are Egyptian, both by their shape and the mode of burial, yet they are closely connected with the "Pan-graves." Many of the graves contained specimens of the incised and black topped pottery common in the X cemetery, and also of the fine, thin, polished variety which was found in grave E 2 (see pl. xxxviii.—xl., and also xxxvi. 185). Animal bones, generally those of gazelles, were common, and there were several instances of bucrania, both plain and painted. Sheep or goat skins, leather work, and twisted fibre are very common, as they were in X: many of the pots were filled with aromatic fat: one grave contained the fragments of an ostrich egg. All these things occur frequently enough in the "Pan-graves," but are, if not unknown in all cases, at any rate uncommon, in the ordinary tombs of the period. Shell and blue glaze disc

beads of the "Pan-grave" type also occur in great number.

79. *The Graves*, which in almost every case faced north, were open oblong pits, 4 to 10 feet deep, 5 to 8 feet long, 2½ to 4 feet wide. The bodies were originally enclosed in stuccoed and painted wooden coffins, but these had in every case been destroyed by white ants, and only stray fragments of the inscriptions could be recovered: these were of the ordinary XIIth Dynasty style (hieroglyphs of birds without legs, &c.). In two cases pottery coffins were used. The few skeletons found *in situ* were in normal position, head usually south, facing east or west. The body, which was only slightly, if at all, mummified, was first wrapped round with cloth; then a layer of stucco was superposed; a mask, painted, and partially covered with gold foil, was moulded over the face, and sometimes the whole was enveloped in a second wrapping of cloth. The hair of the men was short and dark, that of the women was tied up in innumerable plaits, and fashioned into a cumbrous wig on the top of the head, a pig-tail being sometimes left to hang down behind (see two examples in pl. xxv.). The daggers and axes were naturally found with the male skeletons: the scarabs, as usually in Egyptian graves, with the female.



80. *The Pottery.*—(Plates xxxv. and xxxvi.) Thinking it advisable to get as far as possible a complete set of the pottery of this period, we had all the types drawn, even when the example was incomplete.

The bowls, which were of great variety, were for the most part rough, and of a dull red colour; a few, such as 94 and 96, were pebble-burnished, and a few—e.g., 97, which was decorated on the inside with a scabble pattern—were light drab. Pots of shapes 130 and 173, as commonly in XVIIIth Dynasty, presented a brilliant red polished surface: some of the smaller types, such as 152, 154, and 161, were likewise polished, but in a very pale salmon





tint, in some cases almost white. This latter burnish also occurs in the "Pan-grave" pottery, and seems to be peculiar to the period. Types 155 and 160 were sometimes black all over, and unpolished; 145, 146, and 168 were usually drab; 156 and 157 usually contained aromatic fat. Many of the smaller pots were fitted with lids, which appear to have been ground down from any fragment of pottery that lay handy.

Beside the "Pan-grave" pottery, we found three or four specimens of the black incised Italiot ware (xxxvi. 186, 187, 188), found by M. Naville at Khataanah, and assigned by him to the XIIIth Dynasty. No. 184 (see also photograph on plate xxv.) is a curious piece; the ring (broken in this example) is hollow, and connects with the lower pipe, which is open at the end: obviously it was used for some kind of liquid, which was poured in at the cup, ran round the circle, and out from the pipe; but what kind of liquid it was, and why it was passed through in this way, we are at present quite unable to say. The two flat-bottomed pots, with moveable doors, on plate xxv., are also a puzzle: many suggestions have been made as to their use, model corn-bins being perhaps the most likely.

For the pot marks, of which there were a great number, see plate xxxvii.

81. *Stone*.—Of stone statuettes there were three, all in limestone (plate xxvi.). No. 247, at the top left-hand corner, represents a woman, apparently plaiting the hair of a little girl, who is sitting on her knee (Cairo). 471, just below, is the figure of a boy, who from his side-lock was a prince; at the back there is a band of inscription, giving the *seten ta hetep* formula, which unfortunately breaks off just before the name. 524, in the middle of the plate, has a line of inscription down the back which gives the name Ta-sekt (Boston). The base of a fourth statuette, found in grave 208, gives the names of  his father  and his mother .

Two fragments of rough stelae in limestone

give the names of  , and of the  .

The stone vases, which were of alabaster, blue marble, and serpentine, were small and poor. The kohl pots, of alabaster and blue marble, were of the ordinary XIIth Dynasty shape, and had for the most part seen a good deal of service: one in alabaster had been broken anciently, and refitted with a limestone rim. Alabaster was also found in drop-shaped vases, such as 461 in plate xxx., and in small dishes, such as 448. Blue marble occurs also in 461 and 502: serpentine only occurs in shapes such as 245—502 on plate xxix.

82. *Copper*.—The most important object found in this cemetery was the dagger of King Suazenra of the XIVth Dynasty (237, plate xxxii. 17): the crescent handle is of ivory, and the nail holes on the shaft are covered with silver rosettes (Cairo). With it was the axe-head, No. 22 on the same plate. No. 16 is another dagger of the same type, but of inferior workmanship (New York). Nos. 4, 18, 26, and 27 also belong to this cemetery, and with 18 was found the axe-head No. 15. With the exception of 1 and 20 all the axes on this plate (xxxii.) were found in YS, and show well the development from the thick, stumpy axe of the XIIth (3) into the long thin type of the XVIIIth Dynasty (25); 13 and 21 have remains of the wooden handles, and 21 shows the method of fastening, by a cap of copper which fitted over the end of the handle, and the corner of the axe. Nos. 2, 9, and 10 are thin, almost flexible, sheets of copper, of which we do not know the use; 11 and 12 are tweezers of the ordinary type, but 11 was fitted with a block of wood, evidently for safety in carrying. The razors, 33, 34, fish-hooks, 29, 30, and snake, 19, also belong to this cemetery.

Mirrors were found in graves 236, 238, 258, 285, 336, 365, 436, and 445 (plate xxxi.)

83. *Of the other objects* found in this cemetery we will first note the scarabs. Two

other names occur, besides those already mentioned, namely, Shesha (Chicago) and Ya qebher (Cairo). These were found in graves, plundered indeed, but showing no signs of reburial, with pottery of the regular intermediate type; and we have no hesitation in putting them down to the same date as the rest of the cemetery. If, however, we allow that these two kings are intermediate, we must also be prepared to admit that the whole Khyan group of kings, whose scarabs are identical in style, belongs to this period also. The other scarabs found in this cemetery (xli. 13, 14, 15, 16), which are certainly intermediate, point to the same conclusion; the characters on 16 are so exactly similar in style to those of the Lanzone cylinder of Khyan, that there can be very little doubt that the age of both is identical.

Many of the smaller scarabs were inscribed with the formula $\odot \leftarrow \triangleleft$ (see photograph on plate xxvii.). In ivory we have a pair of wands, inscribed with the name of "the servant of the Heqt, Sit-hathor" (plate xxvii., British Museum and Chicago), and on the right hand top corner of plate xxvi. a very finely carved hair-pin, representing a lion standing erect, and holding a man between its paws (British Museum). Pottery dolls, of the large-wigged type, were found in 216 and 320 (plate xxvi., Cambridge): at the bottom of plate xxvi. there is the horn of an animal, which had apparently been used as a musical instrument, the scale of millimetres shews the distances of the holes. The commonest forms of beads were the blue glaze and shell disc, which we have mentioned in the "Pan-grave" connection; other varieties were small carnelian and amethyst, glazed quartz, tiny gold and crumb beads.

84. *Of special graves* we may note the

following:—196. The tomb of "the servant of the Heqt, Sit-hathor": 8 ft. deep, 7 long, 4 wide: remains of a stuccoed wooden coffin, painted on the outside with alternate vertical lines of white, blue, and red, and horizontal lines of white and red; body straight out, turned over on to the chest, arms meeting together at the back; bones covered by a layer of painted stucco between two wrappings of cloth; mask over face, covered with gold foil; hair in tiny plaits; one small glaze bead by the feet, another near the pelvis; by the left hand a twist of fibre; at the south-east end a few gazelle bones; behind the head one of the ivory wands: the other ivory wand, with a few of the ordinary pots, was found in the filling of the grave.

448 was a plundered grave, but a recess cut half way down, at the north end, had escaped notice; in it there were the remains of two wooden boxes, one inlaid with ivory, containing a copper needle, the other, which was stuccoed and painted with chess board pattern, containing a small blue marble kohl pot, a shell used for kohl, and a string of shell and glaze beads; also, loose, the group of alabasters at the top left corner of plate xxx., and two large carnelian beads (Edinburgh).

505. Remains of wooden coffin; skeleton of a man in usual position; bones wrapped in leather; stucco mask over face; on the skull a quantity of short, dark, curly hair; by the right hand a copper axe-head; in the filling of the grave several broken pots of the usual type.

85. *Of real XVIIIth Dynasty remains* we found a few shallow graves scattered among the pit tombs: from these come the later scarabs on plate xli.

CHAPTER XIII.

THE PTOLEMAIC AND ROMAN PERIOD.

86. Of the late remains at Hu there is not much to be said, although we found hundreds of mummies of Roman age; nearly all were of a uniform poorness, with no objects or decoration of any kind.

In one of the pit tombs of older date were found the two open-work glazed beads, shown at the top of pl. xlii. These are probably about the XXIst—XXIInd Dynasty.

A fine gilt cartonnage of Ptolemaic times was found, of which the bust and foot case are in pl. xlii. The name is on a fillet round the head, Pedu-nefer-hotep, son of Hor-uza. This, together with the gilded body covering, is now at Philadelphia.

While digging about the Roman cemetery, south of the fort at Hu, we found a small white marble head of a young king (see pl. xlii.); and though we thoroughly searched the whole top dust in which it lay, and all the graves within ten yards of it, not a chip more was to be found of the statue. From the work, and the quality of the stone, it seems to be early Ptolemaic; but if a Ptolemy, it cannot be earlier than Ptolemy V., 204—181, B.C., by the portraiture (Boston).

87. The great temple enclosure at Hu (see pl. xxiv.) which was later made into a Roman fort, is so much like the brick enclosures of temples of the XVIIIth Dynasty, at Gurob and Nubt, that I supposed at first that remains of that time would be found. I therefore sank pits, and afterwards trenched, in much of the area, particularly about the temple sites in the enclosure; but no trace could be found of buildings, pottery, or other remains, older than the

Ptolemies. Moreover, the wall was seen to be built over some tomb-pits, containing burials of Ptolemaic age. It seems therefore that we cannot place any building here to an earlier date than Ptolemy VII., Philometor (181—146 B.C.), whose name is on a block of sandstone architrave. Professor Sayce informs me of a block of Ptolemy X. seen here.

The plan of the enclosure, with its two temple sites, is confused. The small middle site is apparently that of Philometor, while the only name in the site toward the S.W. corner is that of Nerva. The causeway leading in from the N. gate across the site is paved, and has small portions of a raised edging with rounded top; it runs toward the temple of Nerva. Thus there are two systems of construction, askew to each other. Firstly, there is the main outline of the enclosure, with the Ptolemaic temple in its axis. Secondly, there is the Roman temple built on a new site, necessarily out of the axis, then the road up to it is therefore askew, the temple sides are adjusted to this road, the clearest line of street and the large brick building on the east conform also to this road, and the older wall was breached on the E. side, and rebuilt conformably to the road upon loose rubbish. After that date probably the rounded bastions were added, as one of them is attached to the skew wall.

The enclosure wall is built in short separate lengths, in the usual Egyptian manner; each cross joint of it is left white in the plan. The two southern corners are square, but the sides are all more or less bent. The later alterations of it were the overthrow of the middle of the

E. side, and its rebuilding for at least half its length in the middle, where it rests on loose rubbish 13 ft. deep; also the thickening of the N. or front wall, and building on it the houses of the chief officers of the garrison. Along the inside of the W. wall a lining was added after a great fire; and the owners of houses along this side cut out recesses, cellars, and hiding-places in this wall, as also was done on the inside of the front wall. All of these were cleared out, and also the recesses of the earlier time, which were covered by the lining wall; but no papyrus or anything of importance was found.

The Ptolemaic temple had the traditional deep foundation of sand to it, for which a great hollow was cut in the native marl over 10 feet deep. The plan of it is curiously divided; but no foundations even remained to show its detail, and only a few blocks were discovered loose in the rubbish.

The Roman temple site was not so deeply hollowed; we traced it along the whole S. side and parts of the other sides, but only a few fragments of sculpture remained, one with the name of Nerva. Professor Sayce also informs me of a block of Hadrian seen here. The building has been carried away for stone within this century, as it is described by Nestor L'Hôte, who, however, seems to have seen a Ptolemaic name on it; he may have been misled by the Ptolemaic inscription of the other temple, of which he did not suspect the existence. As his letters are not well known generally, I transcribe the essential part of his account:—

88. "On trouve de ce côté à l'entrée du désert, une enceinte carrée en briques crues renfermant des restes de construction, des ossements et autres débris de momies, et des fragments d'architecture égyptienne. Vers l'angle sud-est (an error for S.W.), à l'intérieur de cette enceinte, il y a un petit édifice en grès, espèce de chapelle à une seule chambre, construite et sculptée sous le règne des Lagides; le plafond est détruit ainsi que la partie supérieure du

monument, à la hauteur des frises; l'édifice a été construit dans une intention funéraire et au nom d'un prêtre, scribe royal, attaché au service d'un Ptolémée. On ne trouve de ce prince que le cartouche nom propre, et parmi les inscriptions, que cet autre cartouche renfermant le titre *grande demeure*. . . . Au milieu de la paroi du fond de cette chapelle est une niche carrée dans laquelle on a sculpté et peint le dieu Sokar-Osiris tenant le fléau et le crochet; il est accompagné à droit et à gauche de la déesse Tmé avec ses attributs ordinaires . . . (after describing scenes of judgment and *Duat*) Je pense que ces figures représentent les heures du jour et de la nuit, sujet observé par Champollion dans les tombes royales de Biban-el-Molouk et ailleurs. J'ai copié dans ce monument le paroi du fond entière et quelques des autres."—"Lettres d'Égypte," Nestor L'Hôte, pp. 109—111.

89. The causeway leading up to the Roman temple must be as late as that, as it points to it, and is askew to the enclosure. It was paved with blocks of stone, laid in between raised edgings 14 to 16 inches thick, with a half-round top. Portions of this edging were found by trenching, and are here inserted as the evidence for the position of the road. The breadth of the road in its best preserved part was $210\frac{1}{2}$ inches between the edgings. This seems rather too much for 10 cubits, as even in Roman time that would not exceed 208 inches; but it might be 18 Roman feet, as that would amount to 209·5, or, in the usual longer foot of Africa, 210·2 inches.

The brick buildings are mostly very ruined houses, destroyed by *sebak* diggers; but one on the east side is noticeable for the size of the plan, and the beauty of the brickwork. The mud bricks are of unusual flatness and evenness, and laid with very close joints; they measure with the joints $14\frac{1}{2} \times 7\frac{1}{4} \times 5\frac{1}{2}$ inches, the thickest bricks of that length I have seen. The building seems therefore to have been for some public

purpose ; and I carefully cleared out all the chambers, but without finding anything. What remains of it is only the substructure, sunk through 7 or 8 feet of town rubbish to a rock basis ; without any doorways between the chambers, which were merely cellar pits under the apparent floor level. The four main dimensions of this building seem to be laid out by the Greek foot, suggesting an Attic architect.

Length . . .	$550 \div 45 = 12.22$	inches
Breadth . . .	$539 \div 44 = 12.25$	"
Longest chamber . . .	$305 \div 25 = 12.20$	"
Next chamber . . .	$183.5 \div 15 = 12.23$	"
Mean	<u>12.22</u>	<u>inches</u>

Around this were found scattered near by four blocks of stone, evidently used for station marks in a survey or plan. The sides were approximately squared, slightly sloping inward ; on the top a slight circular hollow 5.40 inches in diameter, coloured red, and across it two faint lines scratched on the diagonals of the block, and a minute hole at their crossing. It would be impossible to have a better station mark, very visible white stone, with a bright red disc, and delicate lines crossing in the middle of it. Such stones may perhaps have been used in setting out the fine buildings around which they were found.

The houses were irregular in most of the area, but one long street could be traced, belonging to the later orientation of the plan. On the front wall were arched cellars of houses remaining ; and in the west half a deep well went down through the wall, and the hill below, to water level. This was cleared as far as we could ; the iron sword was found in it (base of pl. xlii.), and the bronze busts and other small objects were found in the well or the chamber above it (now at Sydney). In the lowest level of the chamber were coins, mostly of Nero, and some of Hadrian and Antoninus ; while on a higher level were other coins down to Gallienus. So the

occupation of these houses was from about 60 to 270 A.D. No coins of the Constantine family were found, either in the chamber or the town ; so the fort was abandoned probably at the defeat of Æmilian, or that of Domitius.

90. A new class of pottery here belongs apparently to Roman age. Enormous numbers of stands are found (see pl. xlii.), with a conical base, and a saucer-shaped top ; but as they are all pierced through they can only have been for supporting a dish or tray. These lie in thousands of fragments on the rubbish mounds, thrown out of the E. gate of the town into a small ravine at the side : and they are also in the rubbish beneath the rebuilt E. wall. From their numbers they belong to a large population here, and therefore to the Roman garrison, which seems to have begun in the middle of the 1st century ; and they were thrown away earlier than the wall, which was built between the time of Nerva and perhaps Aurelius, or Gallienus at latest. So they must belong pretty closely to the end of the 1st and beginning of the 2nd century A.D.

Upon them are scratched a great variety of marks, the same mark being, however, often repeated, probably as a personal sign. These marks are all copied and published here in pls. xlv.—xlviii. Such a large system of marks, which are quite apart from the known alphabets, raises a serious question as to their origin. And we need not suppose that they belong to Egypt, as there was a Roman garrison, drawn from some other parts of the empire, stationed here.

91. Another trace of such foreigners is found on a sherd of pottery of Roman age, with part of six lines of inscription scratched upon it (see pl. xli). This ostrakon is a token of some troops from the south of Asia Minor ; and it is known that in the 1st century there was a large number of Galatians among the troops as far up as Thebes. It seems not unlikely that these numerous marks on the pottery, as well as the

ostrakon inscription, are due to southern Galatian soldiers.

Of the ostrakon, Prof. Sayce writes:—

“(1) The alphabet is not Karian, though closely allied to the latter. It may perhaps be Kaunian.

“(2) The writing is partly boustrophedon, as is shown by the position of the B.

“(3) The left hand sign in the 4th line, which is not found in the Karian alphabet, is the Kypriote *to*.

“I read therefore

(1) *e-a*

l (?)

(2) *r-a B-ä-u-l*

son of Baul

(3) *l-e (?) a-b-ä*

(4) *w-a-b-i-l o-t-e-to*

(5) *e-a A-b-to-h-e d*

l (?) the Abydian

(6) . . *d (?) -v-u-h-e d (?) -ä-e r (?) -a g (?) -a-u*

son of (?) Kau (nos) ?”

This ostrakon is in the Ashmolean Museum; and though when found I at once showed it to all the workmen, and encouraged them to look for such inscriptions, and also searched hundreds of similar sherds myself, we did not find another fragment.

92. The graffiti of Roman age that we found (pl. xlv.) were on the inner side of the west wall of the town, from opposite the middle of the temple of Nerva northward to the first cross wall. This wall was probably therefore a part of the barracks. There had been a first coat of plaster, of which some part showed remains of figures painted in fresco, of apparently

the 1st or 2nd century A.D. Over that had been spread a later coat of plaster, which was nearly covered with grey scrawling, done with a charred stick. Much of it was quite senseless, and much had decayed, so far as to be illegible; but I copied many names and sketches, all of which were verified by my fellow-workers.

The names of Aurelios Germanos (2), Aurelius, son of Diogenes (1), Theodosios, the philosopher (6), Tiaōs (4), and others can be traced. From the frequent occurrence of Aurelios these are clearly of the 3rd century; but the name Theodosios cannot warrant bringing this group to the 5th century, in view of the general uniformity of it, and the absence of any signs of occupation later than Gallienus. Some drawings are, however, of purely Egyptian source, as the hawk (5) which intersects the Theodosios inscription at *; and the Coptic letters (10).

93. The only Roman object from the tombs is the finely modelled head in coloured plaster, on pl. xlii. It is shown first in three-quarter view alone; and then in front view and profile, along with the skull of the man. I took photographs of the skull with the space between the eyes and lips as in the photographs of the head, and then adjusted the two photographs together, and printed the composite. In the profile it is surprising how exactly true the face modelling proves to be; the excess of the plaster beyond the skull outline is exactly what would be accounted for by the living flesh. We have for the first time an evidence of the skill of the Roman modeller, and an example of the appearance of the living person to compare with the aspect of the skull alone.

I N D E X.

Abadiyeh	1, 2, 13	Beadwork	46
ADY, tomb of	37	BEBA, tomb of	38
Adze, copper	24, 36	BEET-THA, tomb of	38
Agate	27	Beer, dregs of	32
Alabaster vases dated, VIth—VIIth Dynasty	38, 40	Beetles in jar	32-4, 47
,, Xth Dynasty	39	Bird offered in tomb	43
,, XIIth Dynasty	42, 53	Black incised pottery	10, 14, 48, 52
Amenemat III., scarab of	50	Black polish of vases	13
Amethyst	27	Black pottery, coarse	47-8
,, of XIIth Dynasty	42-4, 53	Black-topped pottery	13, 45, 47, 51
Amorite connection	32	,, sequence dates of	8
Amulets, prehistoric	26, 30	Blue marble	42-4, 47, 51-3
,, VIth Dynasty	38-9, 40	Bodkin, copper	24
,, XIIth Dynasty	43-4	Bones wrapped separately	35
Anchylolysis of spine	34	,, of XVIIIth Dynasty buried loose	37
Animal head buried	46	Bracelets of beads	33
Animal bones alone	37-8	,, of copper	37
Animals on combs	21	,, of flint	36
Armlets, ivory	21	,, of ivory	21
Asiatic ostrakon	56	,, of shell strips	45-6
Aurelios Germanos	57	,, three on fore-arm	46
Aurelios son of Diogenes	57	Brick building, fine	55
Axe, copper	25, 36, 51-2	Bucrania	26, 46, 48, 51
,, double	24	Bull's head buried	34
,, of different periods	42, 52	Bull's head amulets	26, 38-40
Ball amulet	27	Burials, contracted historic	38, 40
Ballas	2	,, position of bodies	32, 34, 37-8
Bangles of copper	32, 34, 37	,, of mutilated bodies	32-3, 35-6, 39, 45
Basket-work patterns	14	,, of two or more bodies	32-3, 35
Baskets	47	Burnt stratum in valley	34
Beads	27	Butmir, pottery from	14
,, around skull	35, 38	Buttons, dated	39-40
,, in eyes of skull	35	Calcite	27
,, on bones	45	Carbonyl gas	13
,, cruciform and star	36	Card catalogue of graves	5
,, VIth—VIIth Dynasty	39, 40	Carnelian	26-7
,, XIIth Dynasty	42, 44	Cartonnage gilt	54
,, of Pan-graves	46	Cemeteries excavated	31-2
,, XIIIth—XVIIth Dynasty	53	Cemetery A	32
,, XXIIInd Dynasty	54	,, B	32

Cemetery C	34	Dogs, buried	33, 38, 48
" D	37	Doll, ivory	44
" E	45	" pottery	44, 53
" H	35	Eggs, models of	33
" J	32	Ensigns of ships	16
" N	38	Eye-paint, green	20, 47
" R	35	Face pendants	22, 25
" U	35	Face-veil	22
" W	38, 43	Fancy forms of pottery	14
" X	45	" sequence dates of	9
" Y	39, 44	Fat in jars	15, 47, 51
" Y S	50	Felspar, green	38, 43
Chisels, copper	24, 36	Figures of men	26, 36
" model	33, 43	Finger rings, ivory	21
Cienpozuelos, pottery from	14	Fish amulets	40, 43
Cist of pottery	33, 36	Fish hooks	52
Classification of periods	5	Fish vase	44
Claw amulet	27	Flaying knife, copper	24
Coffin of wood	35, 38-9, 43-4, 51, 53	Flint bracelets	36
Combs, ivory	21	Flint forms, history of	23
Copper axes of different periods	42	Flint working, history of	23-4
" bangles	32, 34, 37	Fly amulet	26, 34, 44
" foil	25	Forehead pendants	22, 34
" models of vases, &c.	37, 43	Forked lance of flint	23
" needle	24, 38, 53	Foundation of sand	55
" pin, earliest	13, 24, 28, 34	Frog amulets	26, 40
" tools	24, 36, 47	Galatians	56
" wire	25	Galeno	25
Coral tubes	27	Galleys, as figured on pottery	15
Corn-bin models	52	Garnet beads	44
Cornice of poles	37	Glazed pottery beads	27
Crocodile amulets	26	" quartz	26
Cross-lined pottery	6, 14	Goat heads, hung up	46
" sequence dates of	9	Goat skins	13, 32, 34, 36
Cruciform beads	36	Gold foil over limestone	25, 38
Cut up bodies	32-3, 35	Gold objects	25, 27, 39, 40-1, 43-4, 53
Cylinder, ivory, inscribed	36	Graffiti, Roman	57
" of copper	24	Graves, direction of	42-3, 51
Dagger, flint	23	" earliest known	13
" forms of	42	" sequence dates of, worked out	11, 12
" of Suazenra	52	" shallow pan-shaped	13, 28, 45
Dates offered in tomb	43	Green eye-paint	20, 47
Decorated pottery	6, 15	Grinder stones	47
" sequence dates of	10	Haematite	27, 44
" age of designs	15	Hair-pins, ivory	21
Degradation of pottery forms	5, 15	Hand amulet	39
" of slates	20	Hand-working of stone	19
Dendereh	2		
Deposit of mud, rate of	28		
Diorite vases	40		
Direction of tombs	42		

- | | | | |
|---|----------------|---|--------------|
| Harpoons | 22 | Masks on heads | 51, 53 |
| Hathor amulet | 41 | Measures | 55-6 |
| Hawk amulets | 26, 40, 44 | Mena, tomb of | 2, 15 |
| Hawks on ring | 22 | Min, statues of | 2 |
| Hedgehog, blue glazed | 44 | Mirrors | 38-9, 43, 52 |
| <i>Hez</i> hieroglyph, origin | 24 | Modelled head in stucco | 57 |
| Hippopotami, figures of | 33, 35 | Morgan, M. de | 2 |
| Hissarlix, pottery from | 14 | Mutilated burials | 32 |
| Hoe model | 33 | | |
| Horn, musical | 53 | Naqada | 2 |
| HOTEP-AQERA, stele | 41 | Needles of copper | 24, 38, 53 |
| Hu temple enclosure | 54 | НЕКНТΥΚ stele | 41 |
| Human figures | | Neolithic age | 28 |
| | | Nestor L'Hôte quoted | 55 |
| Incised black pottery, sequence dates of | 10 | Nile deposits | 28 |
| Intermediate pottery, XIIIth—XVIIth Dynasties | 50 | | |
| Italiot pottery | 52 | Obsidian | 27 |
| Ivory carvings | 21 | Offering pits | 37-8 |
| „ cylinder inscribed | 36 | Offerings, tray of | 43 |
| „ doll | 44 | Ointment in jars | 15, 47, 51 |
| | | Orme, Miss | 2, 3 |
| Kabyle pottery | 14, 30 | Ox heads hung on buildings | 26 |
| Karian alphabet | 57 | | |
| Kaunian alphabet | 57 | Paint on animal skulls | 46, 51 |
| Khyan scarabs | 53 | Palaeolithic age | 28 |
| Knives of flint | 23 | Palestine pottery | 15, 30 |
| Koptos, work at | 2 | Pan graves | 45-9 |
| | | Pebble grinders | 20, 34 |
| Lances of flint | 23, 33 | PEDUNEFER HOTEP, cartonnage of | 54 |
| Late pottery | 5, 16 | Pegs of ivory | 21 |
| „ sequence dates of | 11 | Pendants for forehead | 22 |
| Lawes, Miss | 2, 3 | Pins of copper | 24 |
| Lazuli | 26-7 | Pits, for offerings | 37 |
| Lead objects | 25 | Polished red pottery | 13 |
| Leather work | 47, 51 | „ sequence dates of | 9 |
| Leg amulets | 38-9 | Porphyry, red, amulet | 27 |
| Libyans | 13, 29 | Pottery used for arranging sequence | 4-7 |
| Linen cloth | 46 | „ sequence dates of | 8-11 |
| Lions on ring | 22 | „ descriptions of | 13-17 |
| Lion and man, on pin | 53 | „ material of | 13 |
| Livingstone's use of malachite | 20 | „ buried alone | 32, 45 |
| | | „ large amount in grave | 33 |
| Mace-heads | 24 | „ of Pan-graves | 47 |
| Maces with handles | 24, 33 | „ of XIIth Dynasty | 50 |
| Mace, Mr. | 2, 3 | „ between XIIIth—XVIIth Dynasties | 50-1 |
| Mac-Iver, Mr. | 2, 3 | Prehistoric age :— | |
| Majorca, bronze bulls' heads | 26 | Past work on | 2, 3 |
| Malachite eye-paint | 20, 47 | Sequence of periods | 4-8 28-30 |
| Marble head of king | 54 | Pottery | 8-11 |
| Marble, pale blue | 42-4, 47, 51-3 | Earliest stage | 28, 34 |
| Marks on pottery | 29, 52, 56 | Early age | 29 |
| | | Decadence of | 30 |

Late age	30	Sites excavated	1
Length of	28	SITHATHOR, wands of	53
Changes in style	29, 30	Slate palettes	13, 20, 34
Very late tomb	32	" use of	20
Ptolemaic temple	54	Slave figures buried	26
Quartz	27	Slip catalogue of graves	4
" glazed	26, 27	Soul-house	43
RANSENB, statuette of	40	Spear-head amulet	27
Razors	52	Spoons, ivory	21-2, 34
Rhombic beads	42	Star beads	36
Ring-jar	52	Station-marks of surveyor	56
Rings with animal figures	22	Statistical sorting of types	6
Roofing of tomb	33	Statuettes	40, 43-4, 52, 54
" with round poles	37	Steatite beads	27, 34, 36
Rough-faced pottery	16	Stone vases	18
" sequence dates of	10	" types of	18
Sand blown in valleys	34	" materials of	19
Sandals, ivory model of	22	Stucco mask on heads	51, 53
" leather	46	" modelled head	57
Saucer-shaped graves	13	Suazenra, dagger of	52
Scarab beetles in jar	32-5	Sword, iron	56
Scarabs	42, 52	TA-SEKT statuette	52
" found with women	51	Theodosios the philosopher	57
Scorpion amulet	27	Tiaōs	57
Scraper of flint	24	Tombs, direction of	42
Scratch combs	21	" sequence dates of, worked out	11, 12
Seal of VIth Dynasty	39	Tools of copper	24
SEBEKHOTEP, statuette of	52	Tray of offerings	43
SENT, statuette of	43	Turquoise	27
Sequence of prehistoric ages	4	Tusks of ivory	21
" dates	4	Tweezers on block	52
" " scale of	5	UHA, tomb of	38
" " mode of arranging	5-8	Usertesen I., scarab of	50
" " list of types	8-11	Ushabti of XIIth Dynasty	43
" " of tombs worked out	11-12	Vase amulet	27
Serpentine, transparent	21, 26	Wall model, with men	32
Servants, burials of	40	Wavy-handled jars	5, 15
Sewn leather	47	" sequence dates of	10
Shesha, scarabs of	52	White paint on pottery	51
Ships figured on pottery	15	Wire	25
Signs, use of	29	Woman plaiting child's hair, statuette	52
Silver objects	25, 27	Wooden coffins	35
		Yaqbher, scarab of	53
		YI, statuette of	52

LONDON :
GILBERT AND RIVINGTON, LIMITED,
LITTLE SUTTON STREET, CLERKENWELL, E.C.

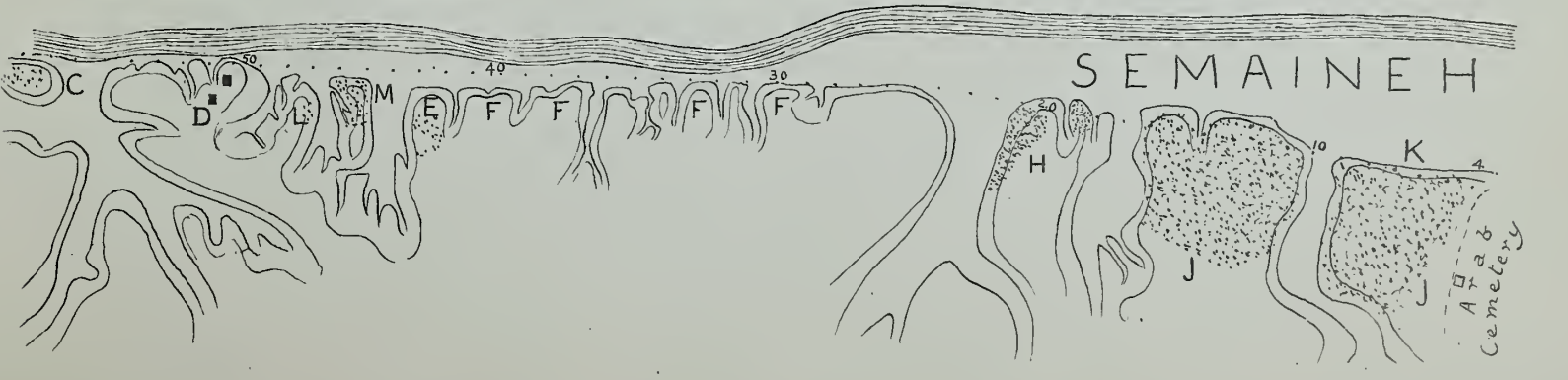
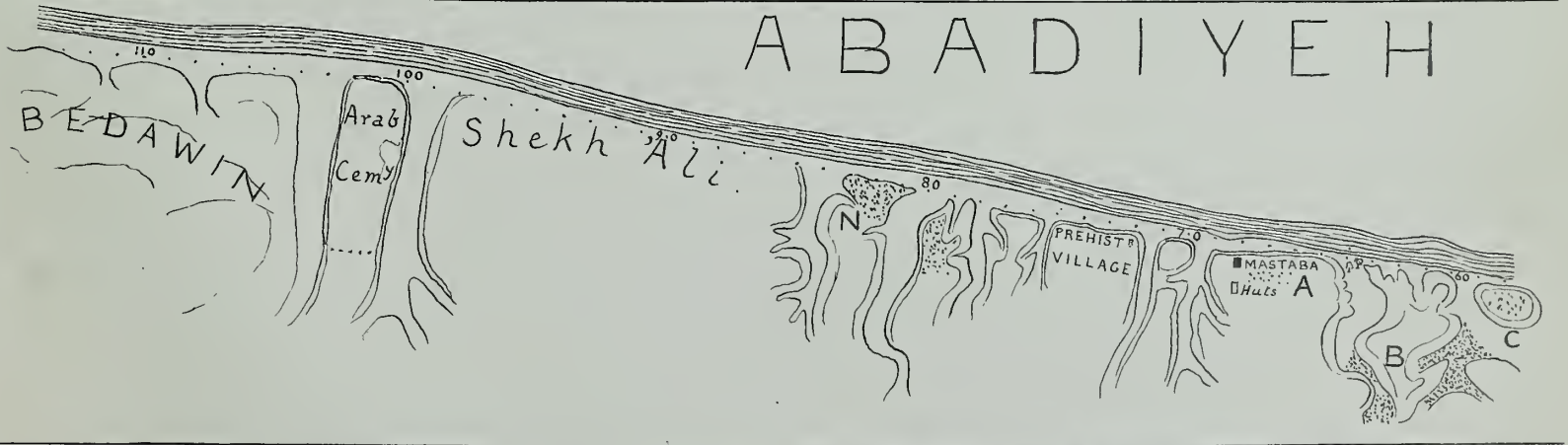
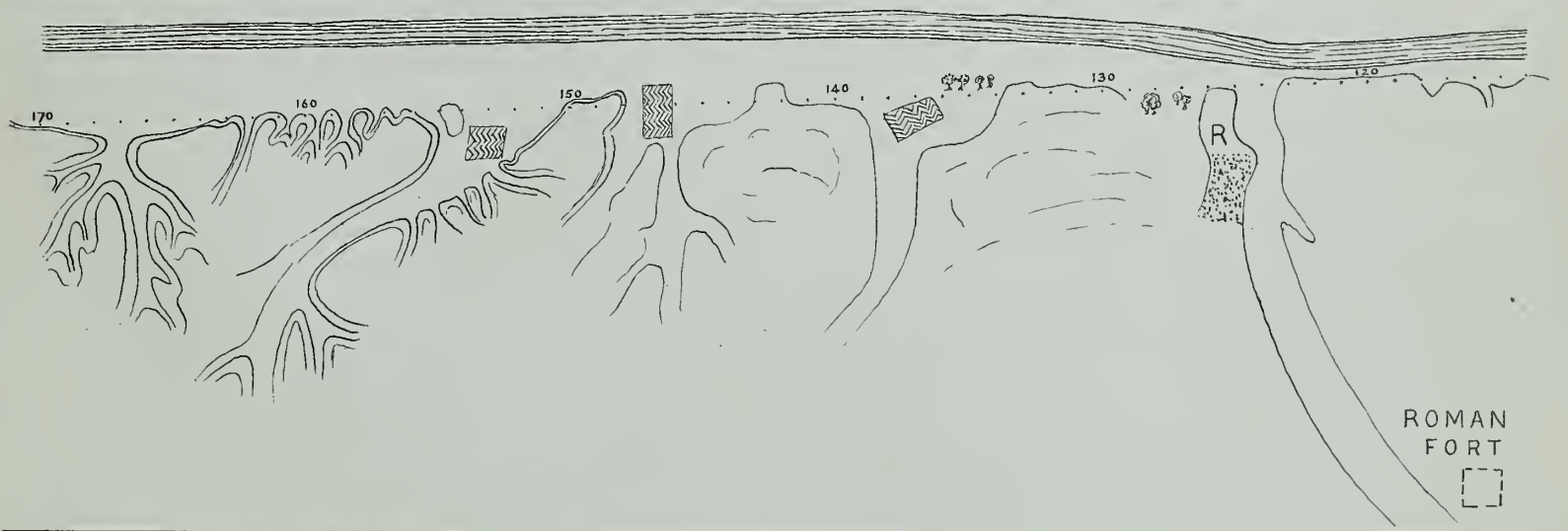
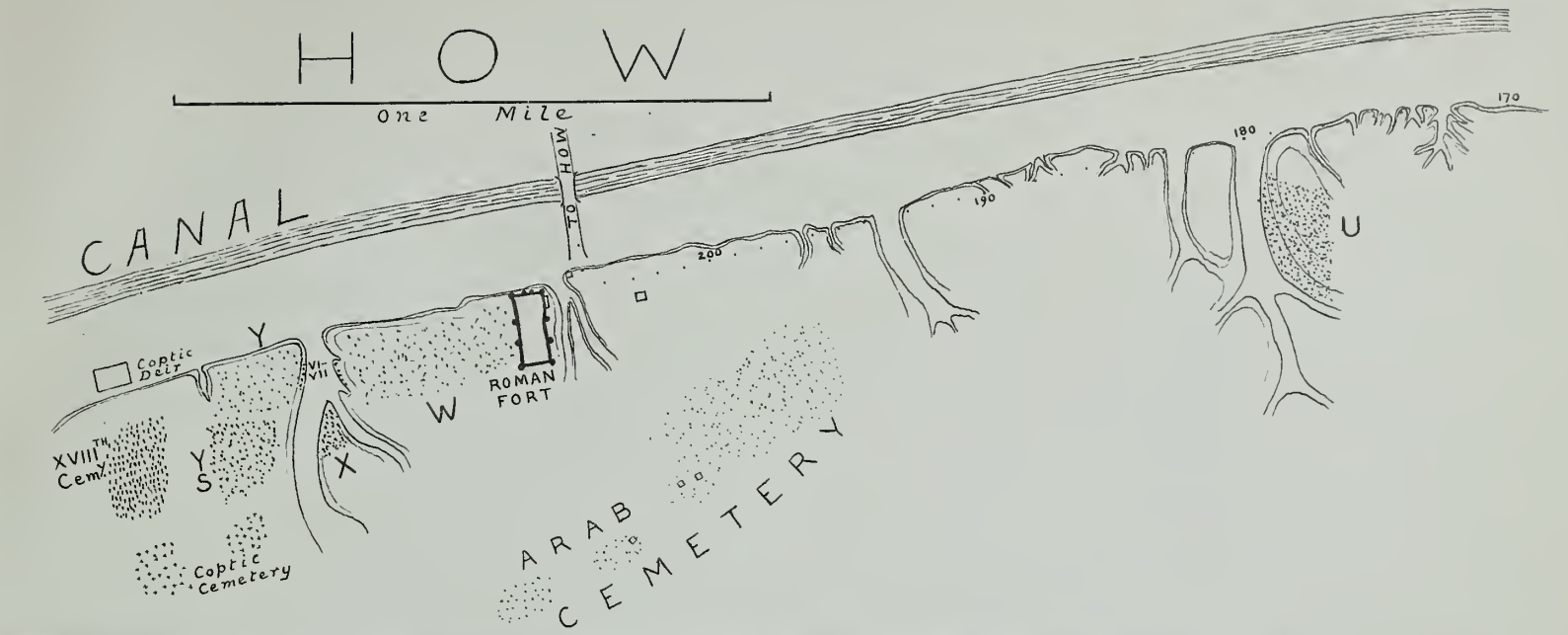

POTTERY OF SUCCESSIVE PREHISTORIC PERIODS.

II.

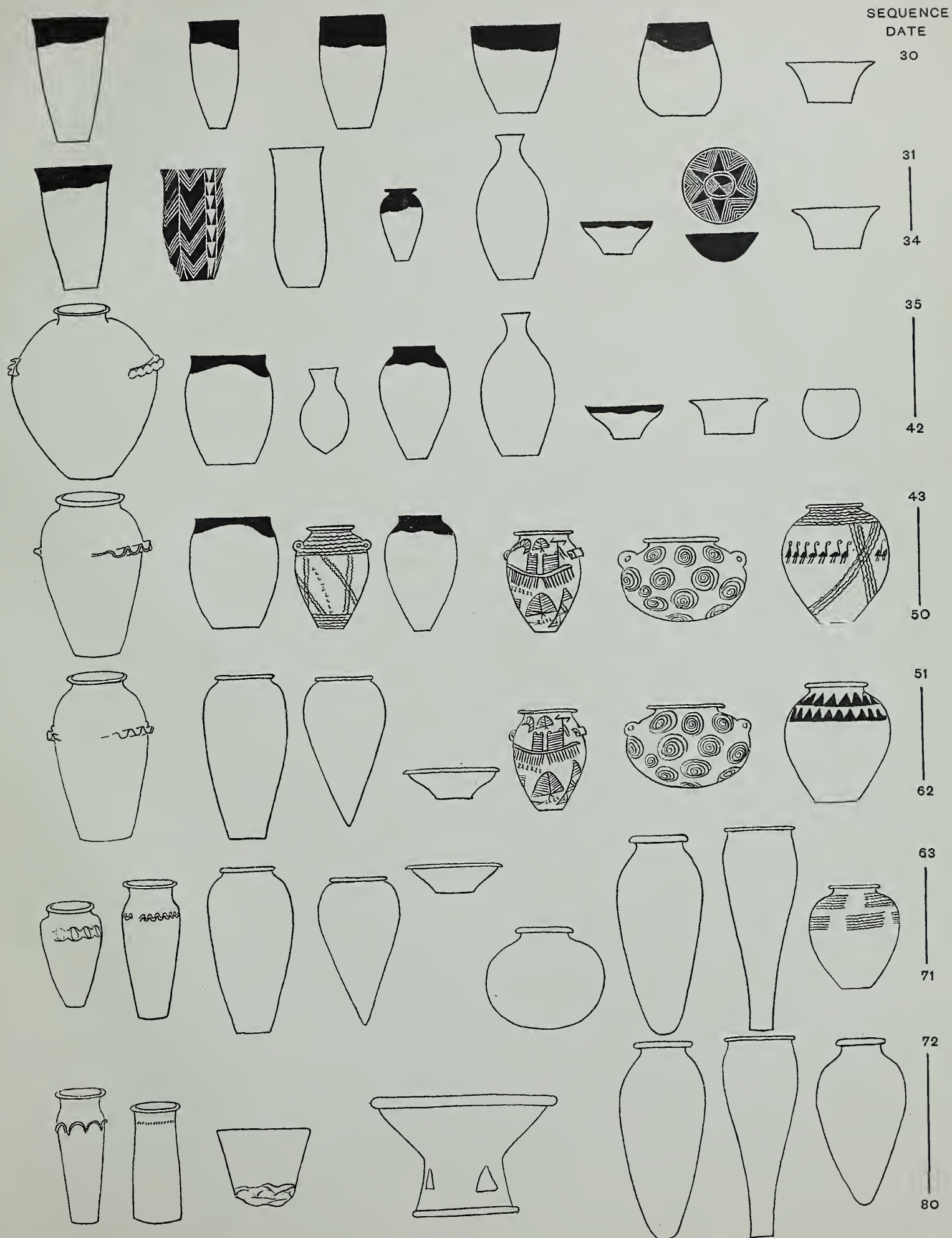



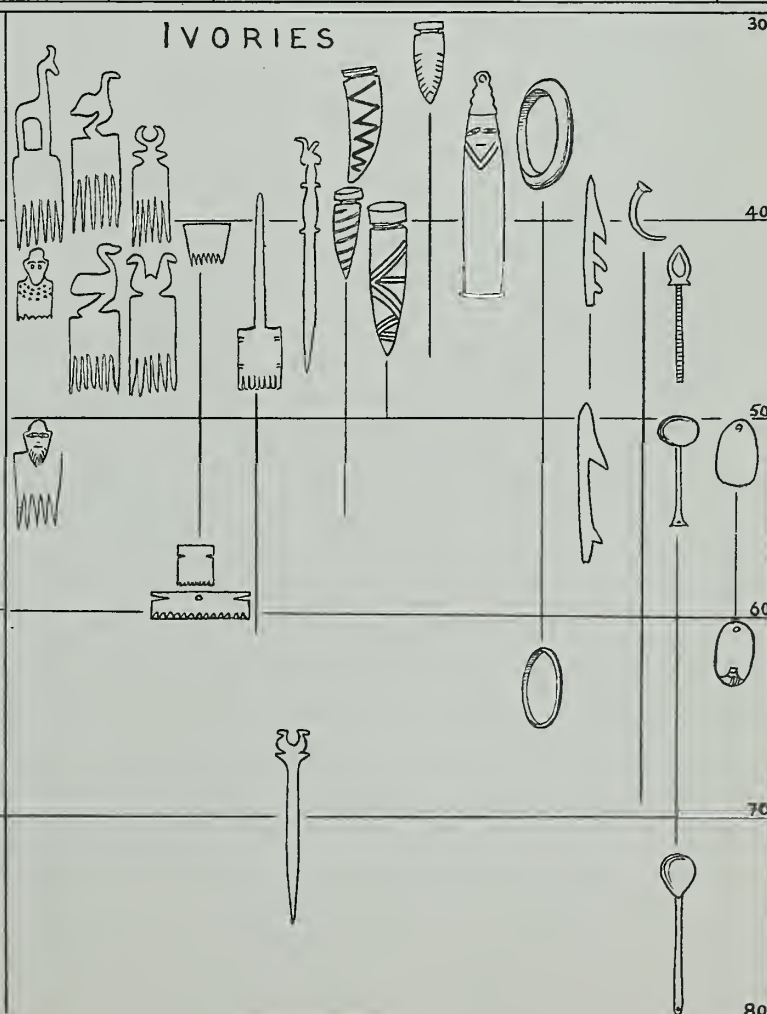
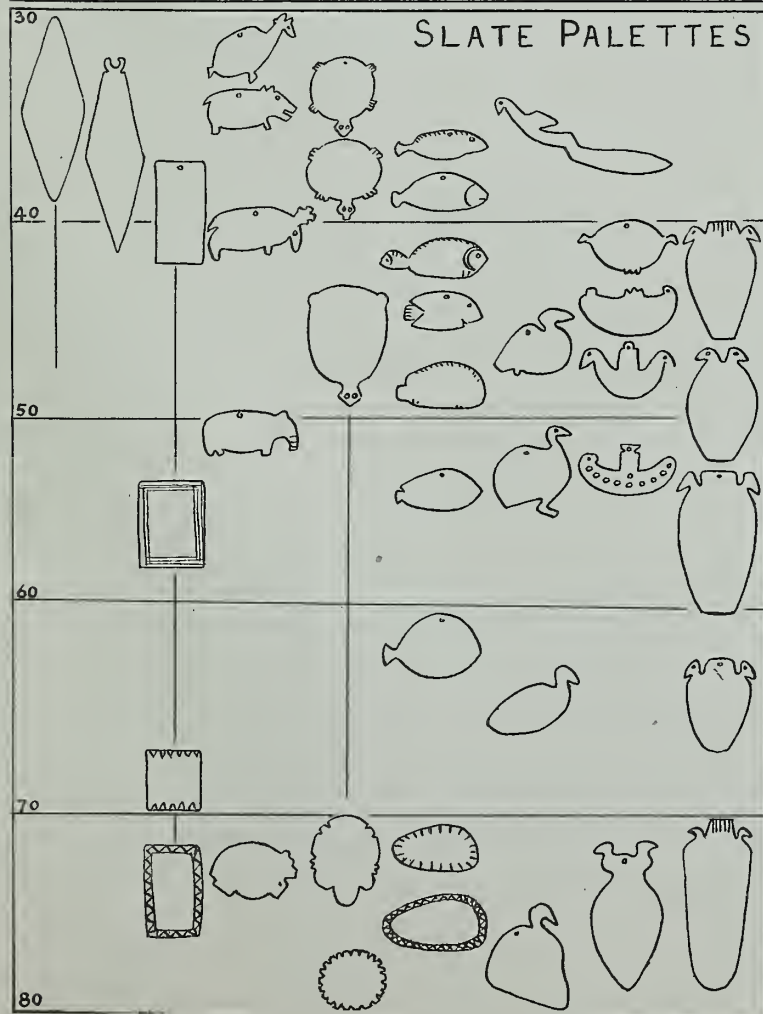
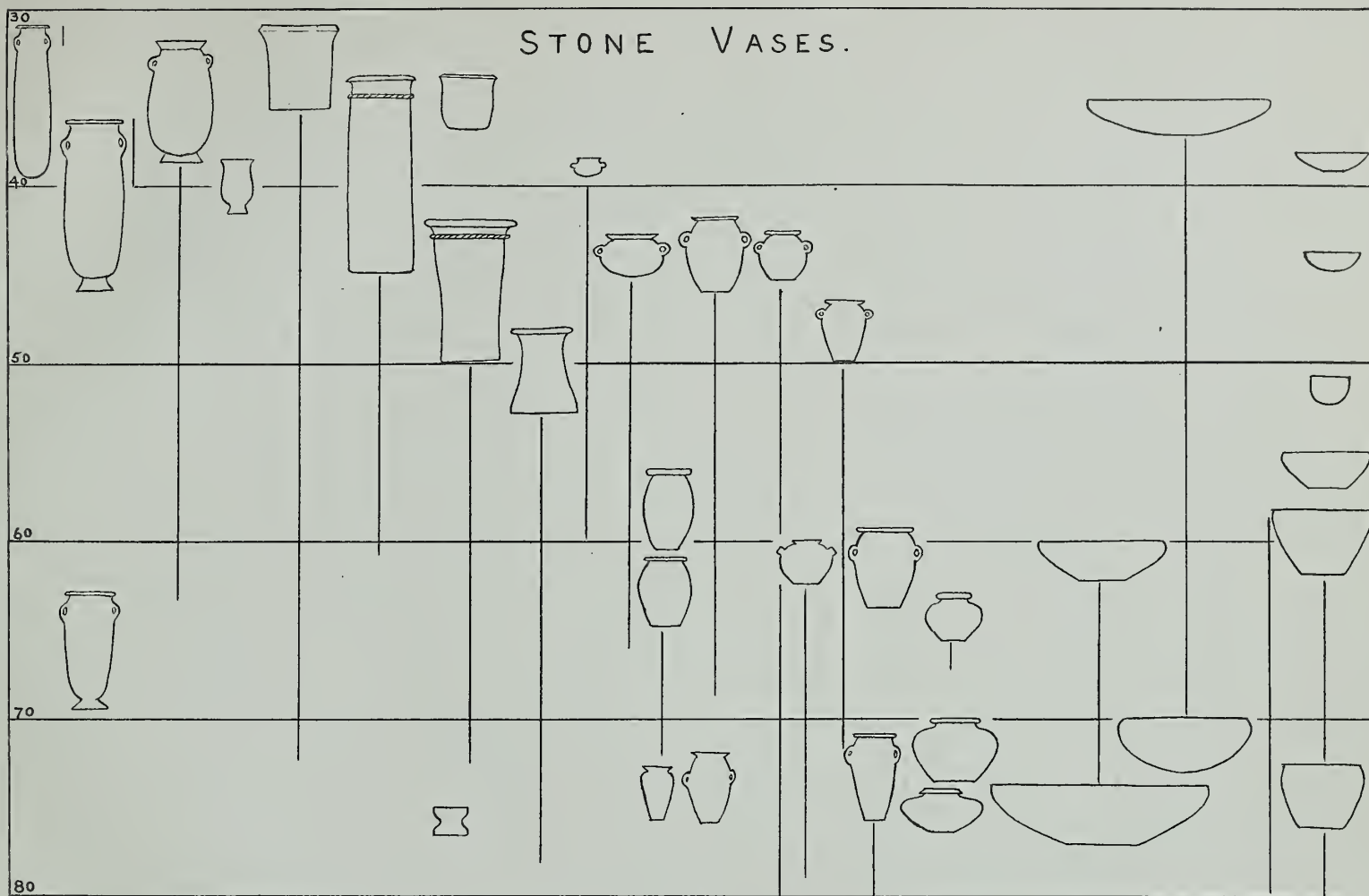

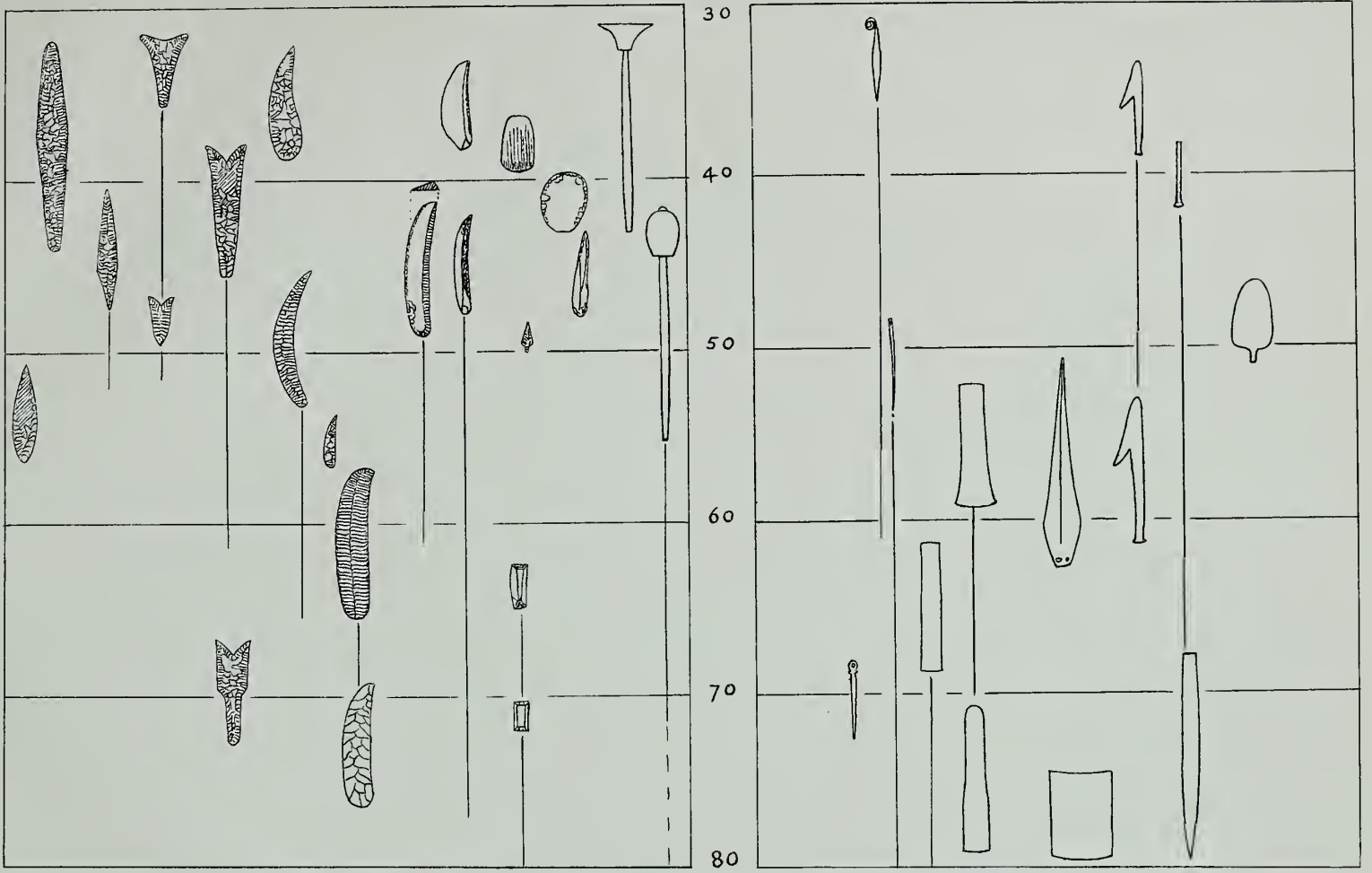

FLINT IMPLEMENTS

COPPER IMPLEMENTS

MATERIALS OF BEADS

STANDARDS OF SHIPS

AMULETS

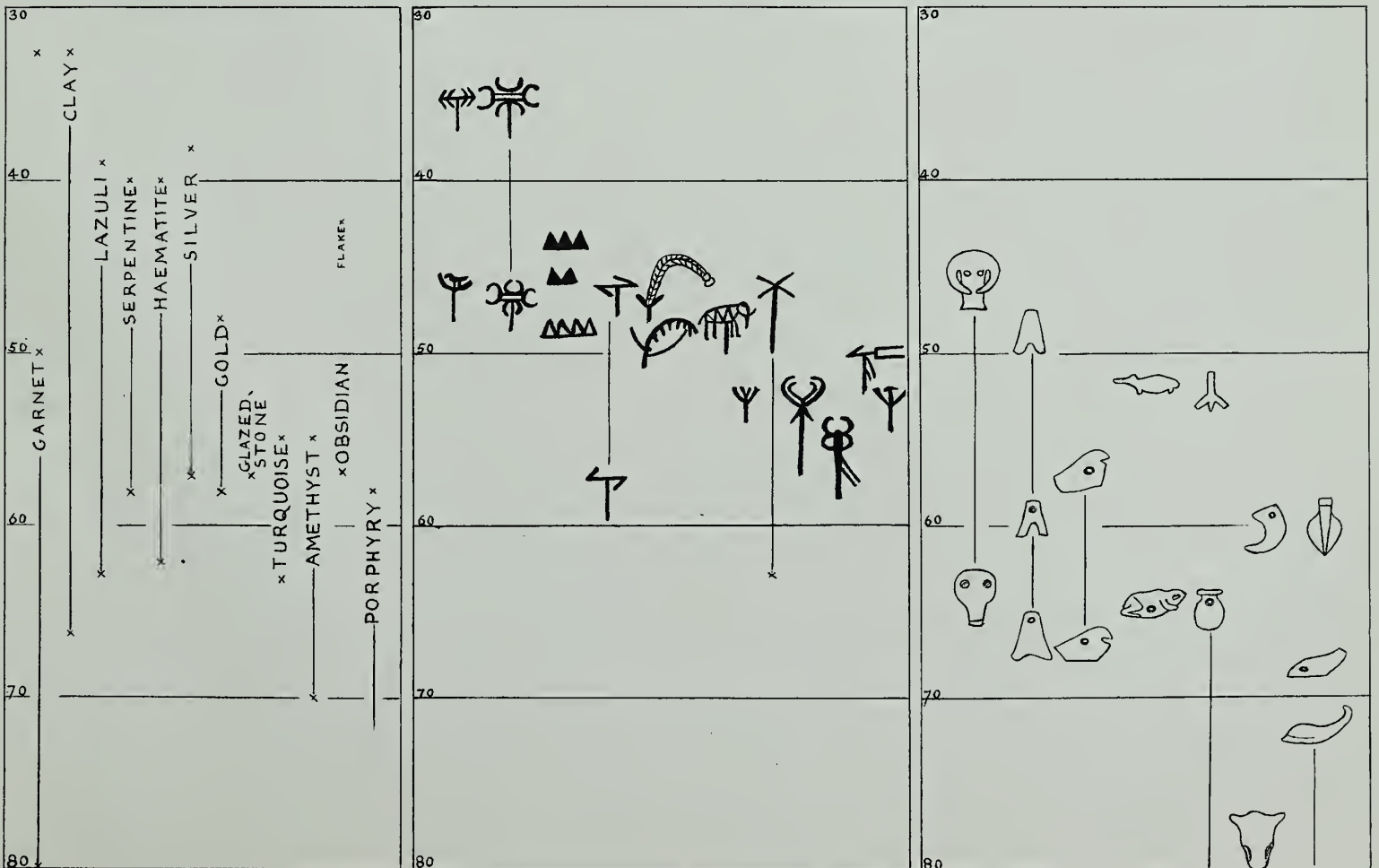

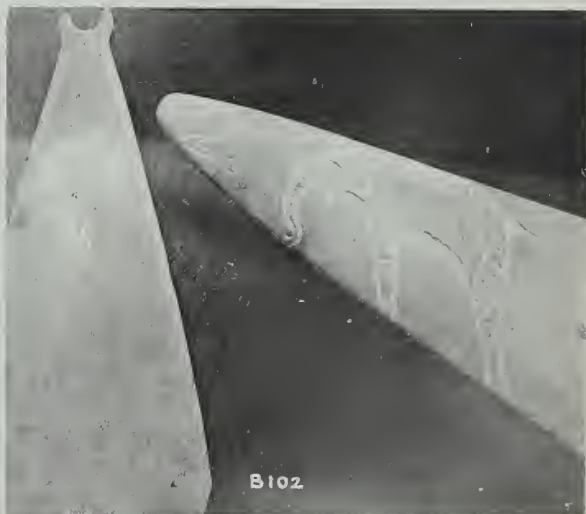

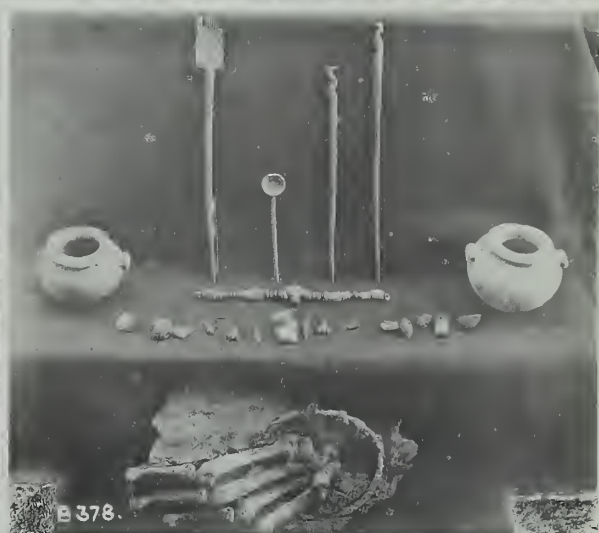
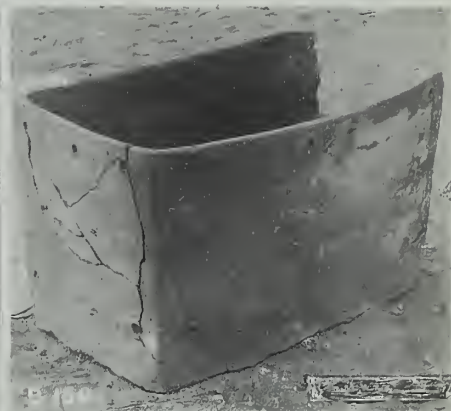
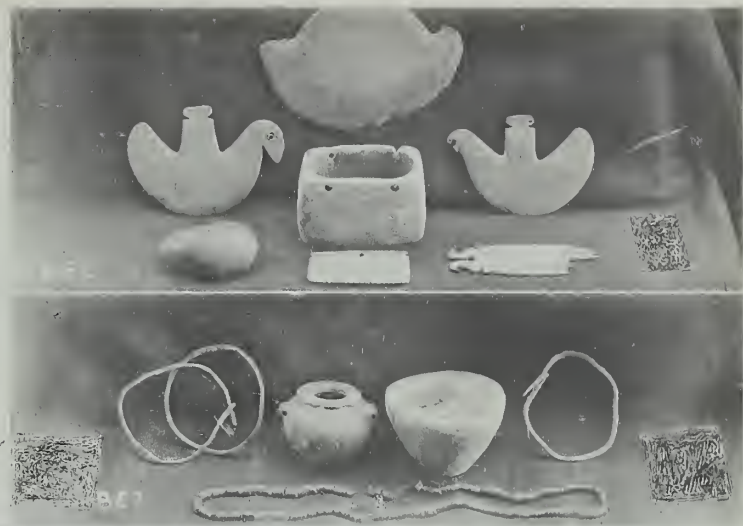

B 109.

B 236.

B 328.

B 119.

B 378.

B 378.

A. 134.

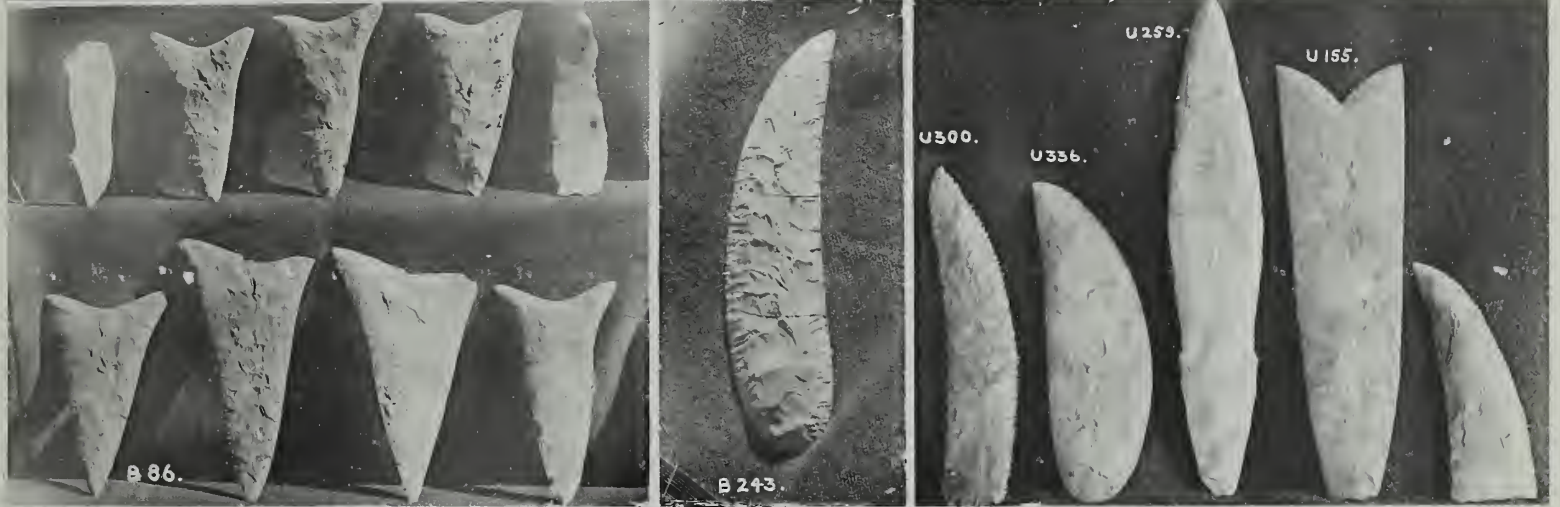
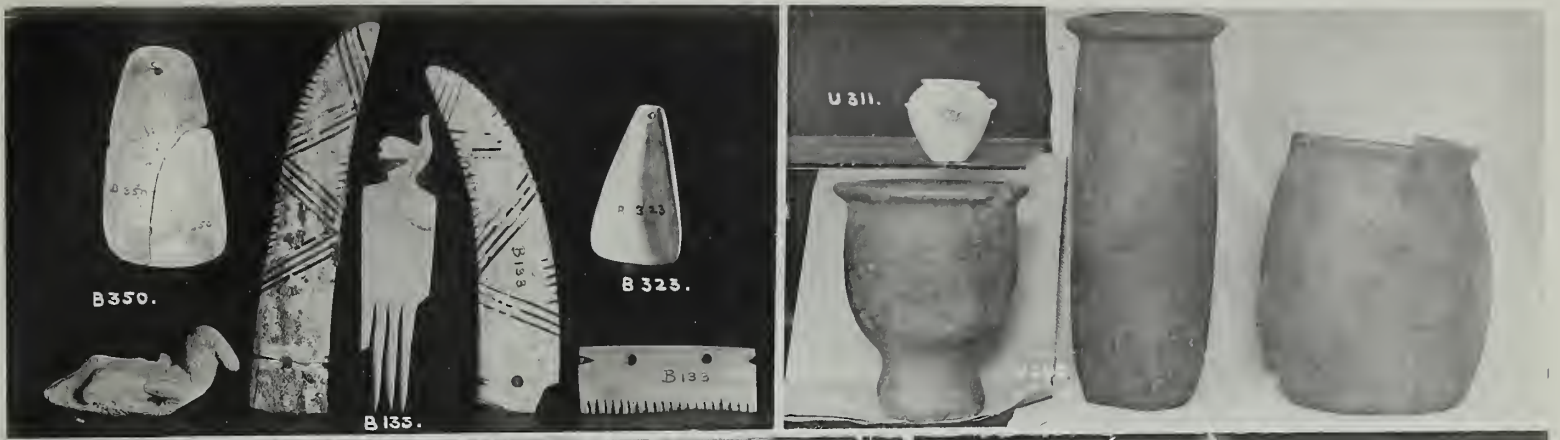

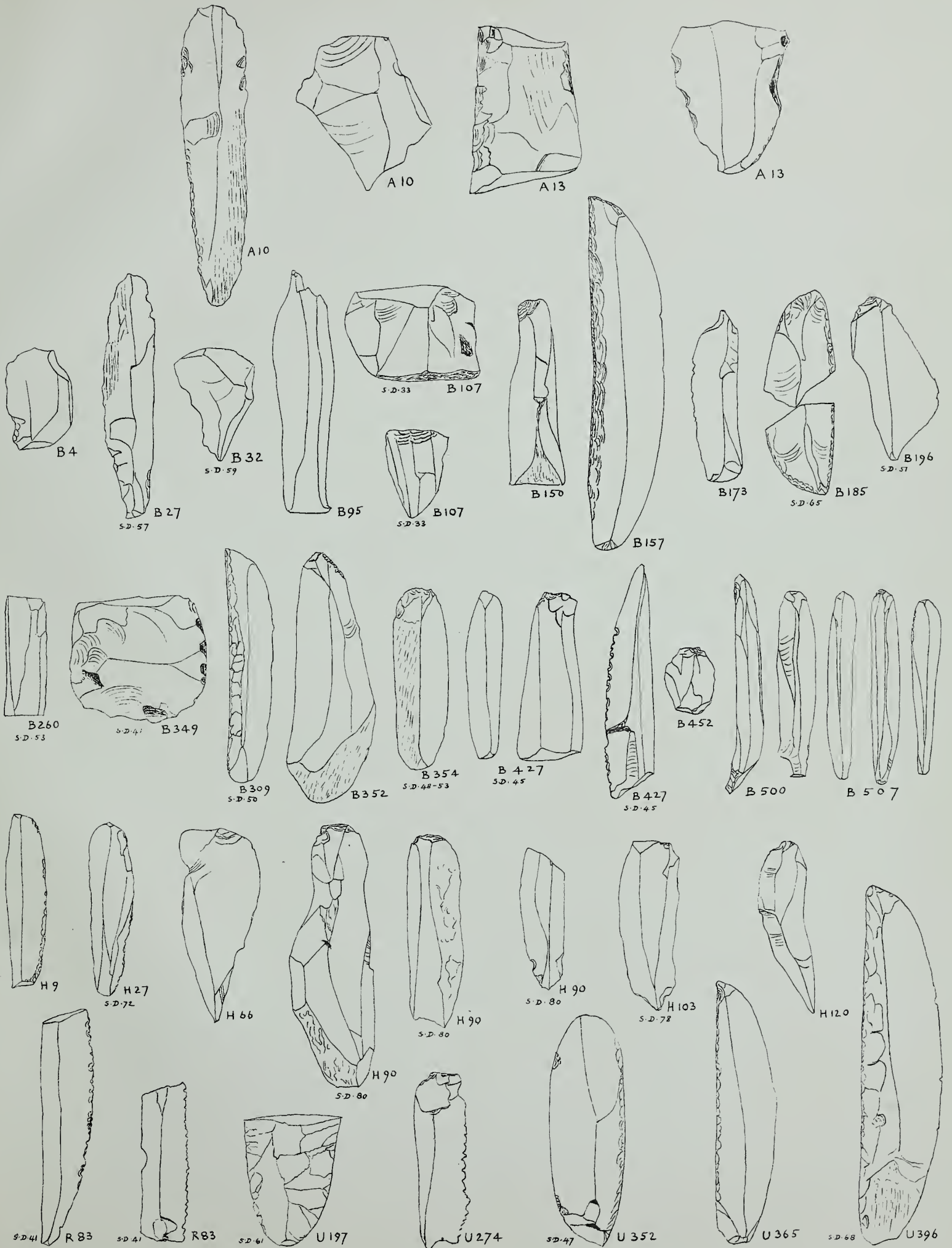

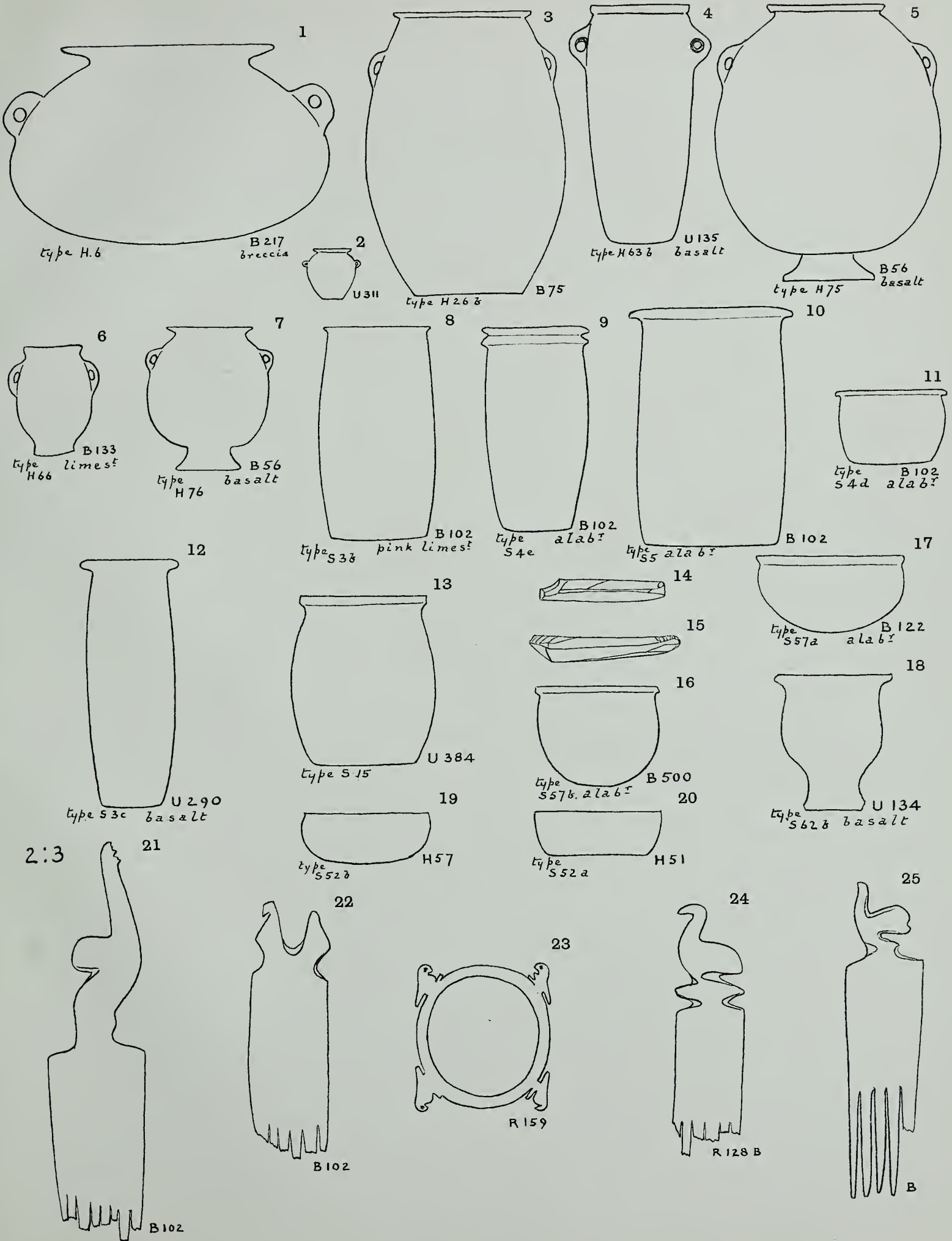

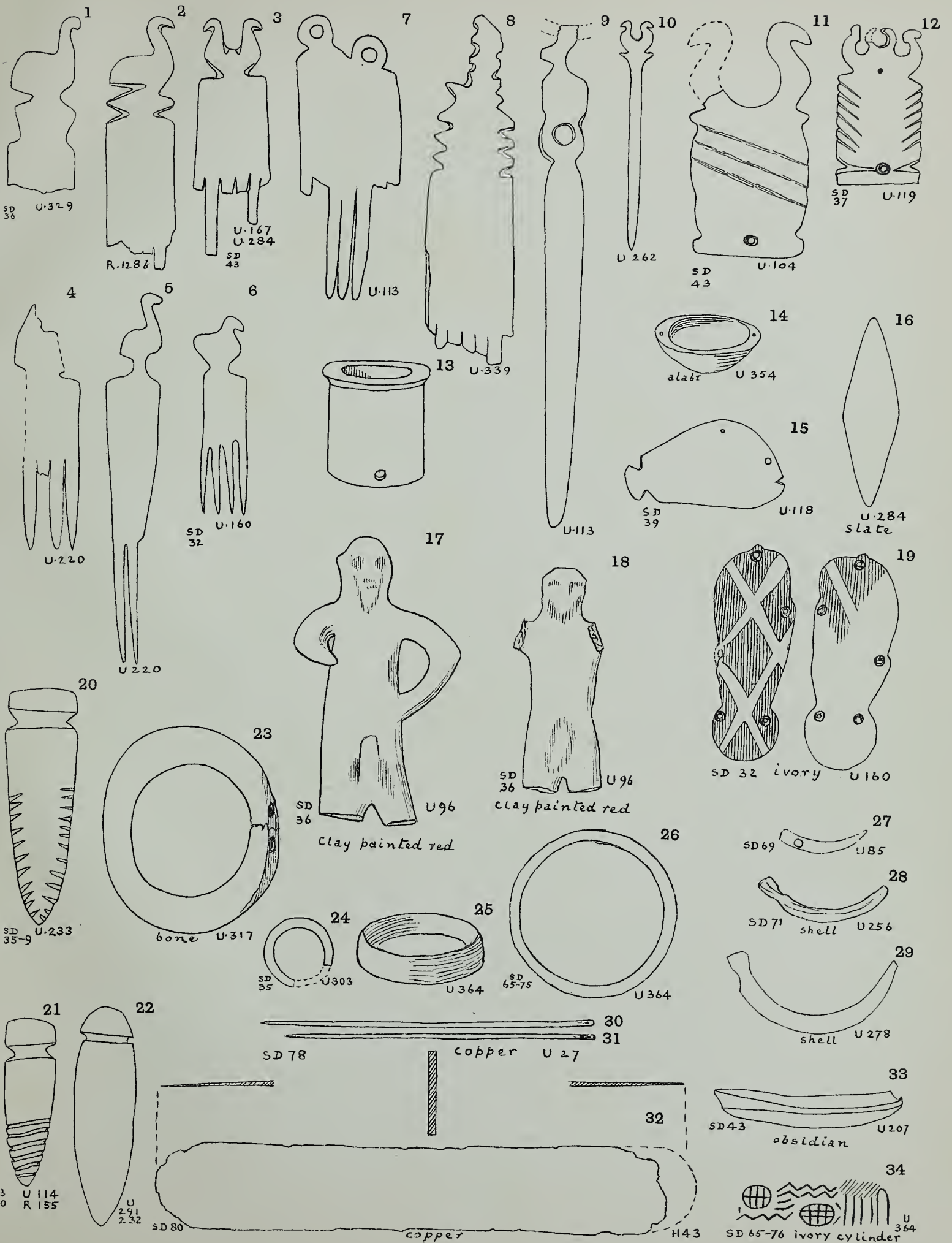

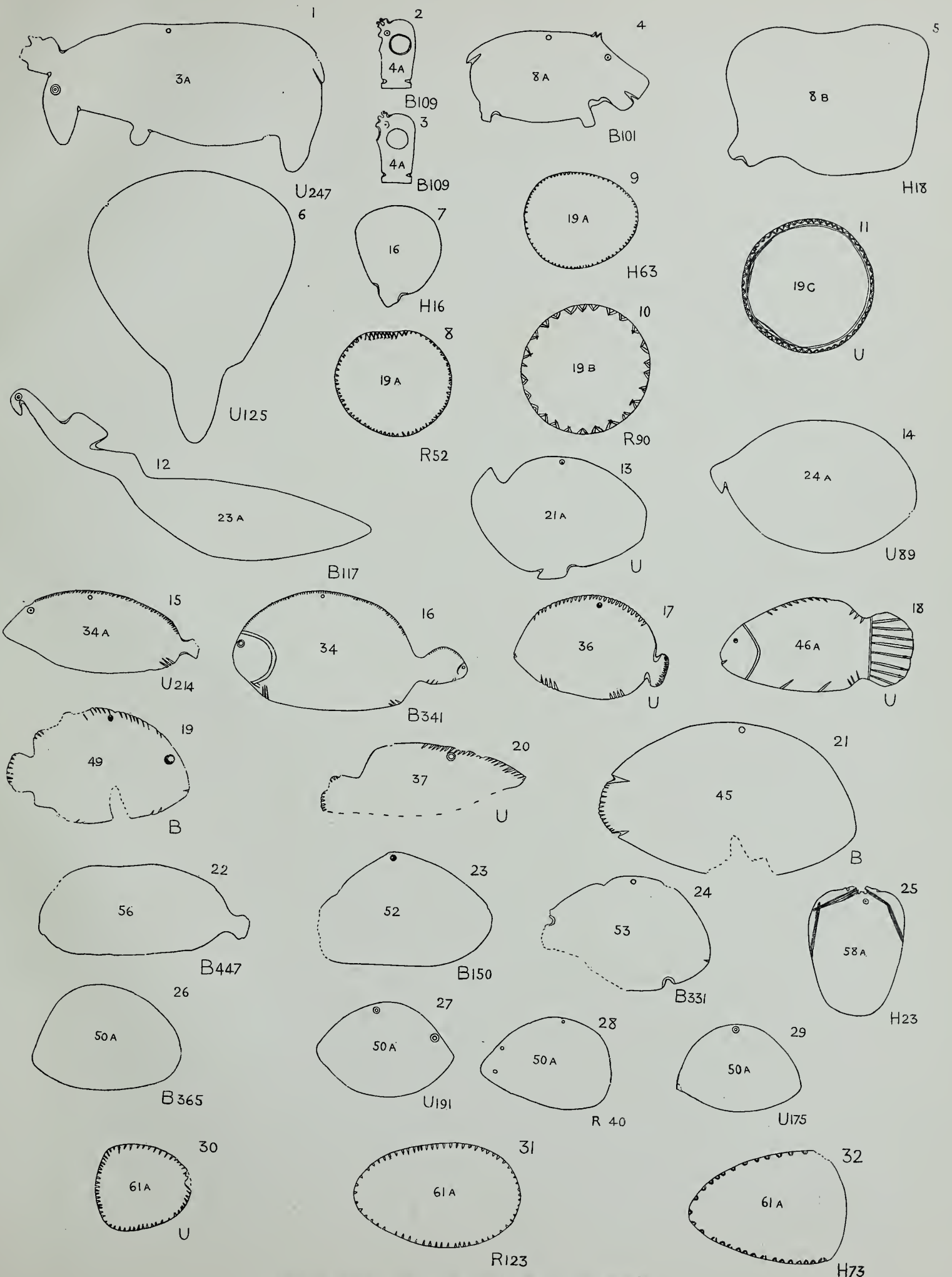

Top, reference number; base, tomb number; middle, type number.

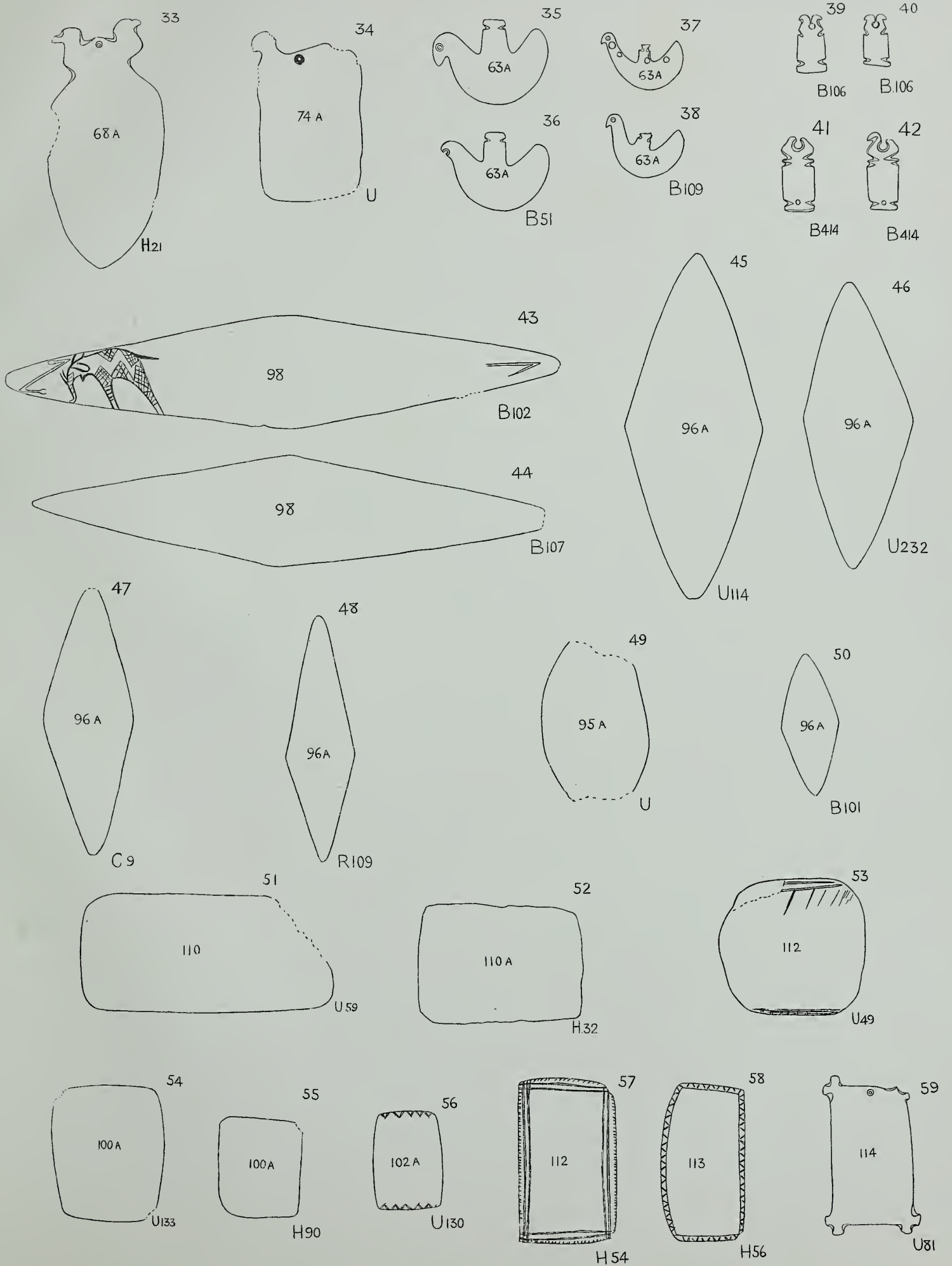

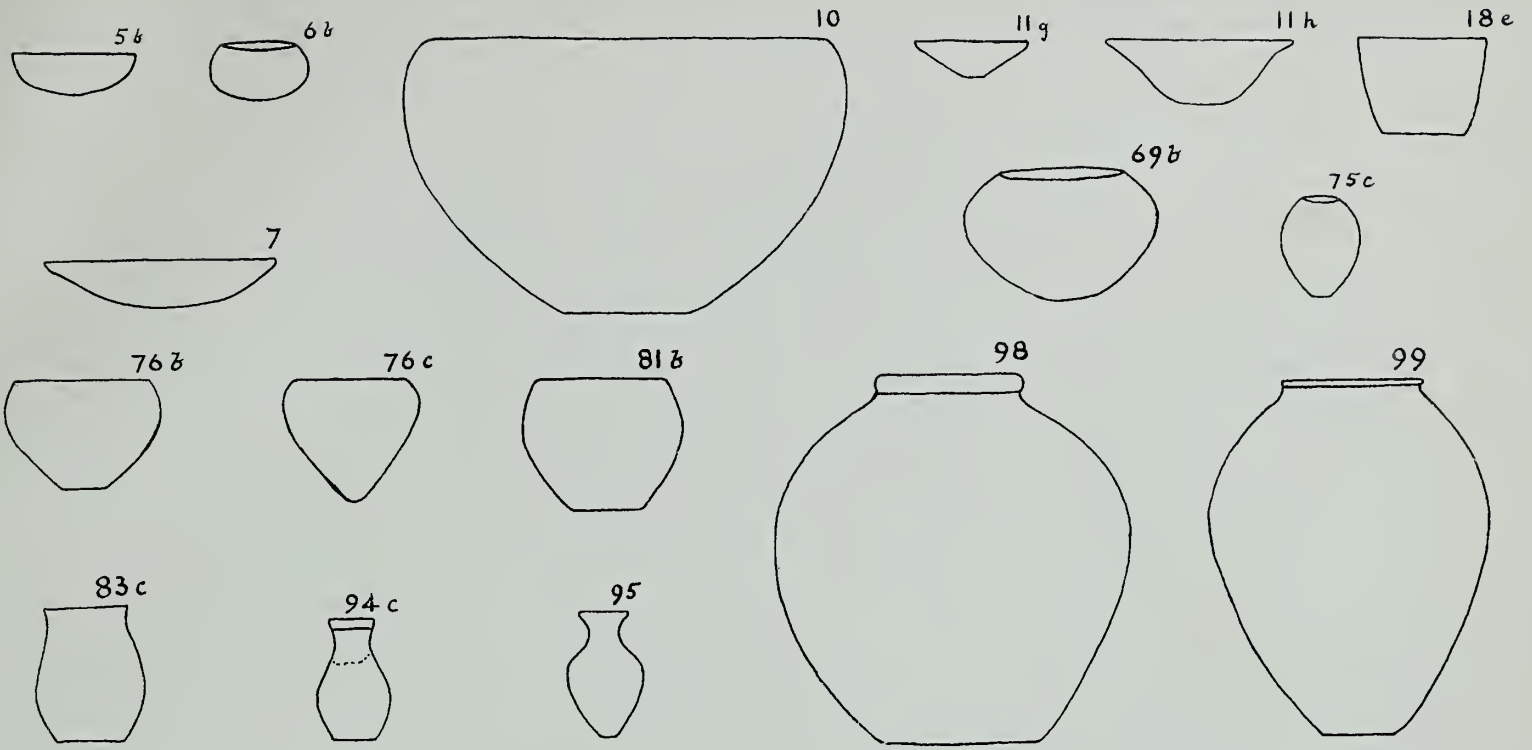

POLISHED RED POTTERY, P 1-99.

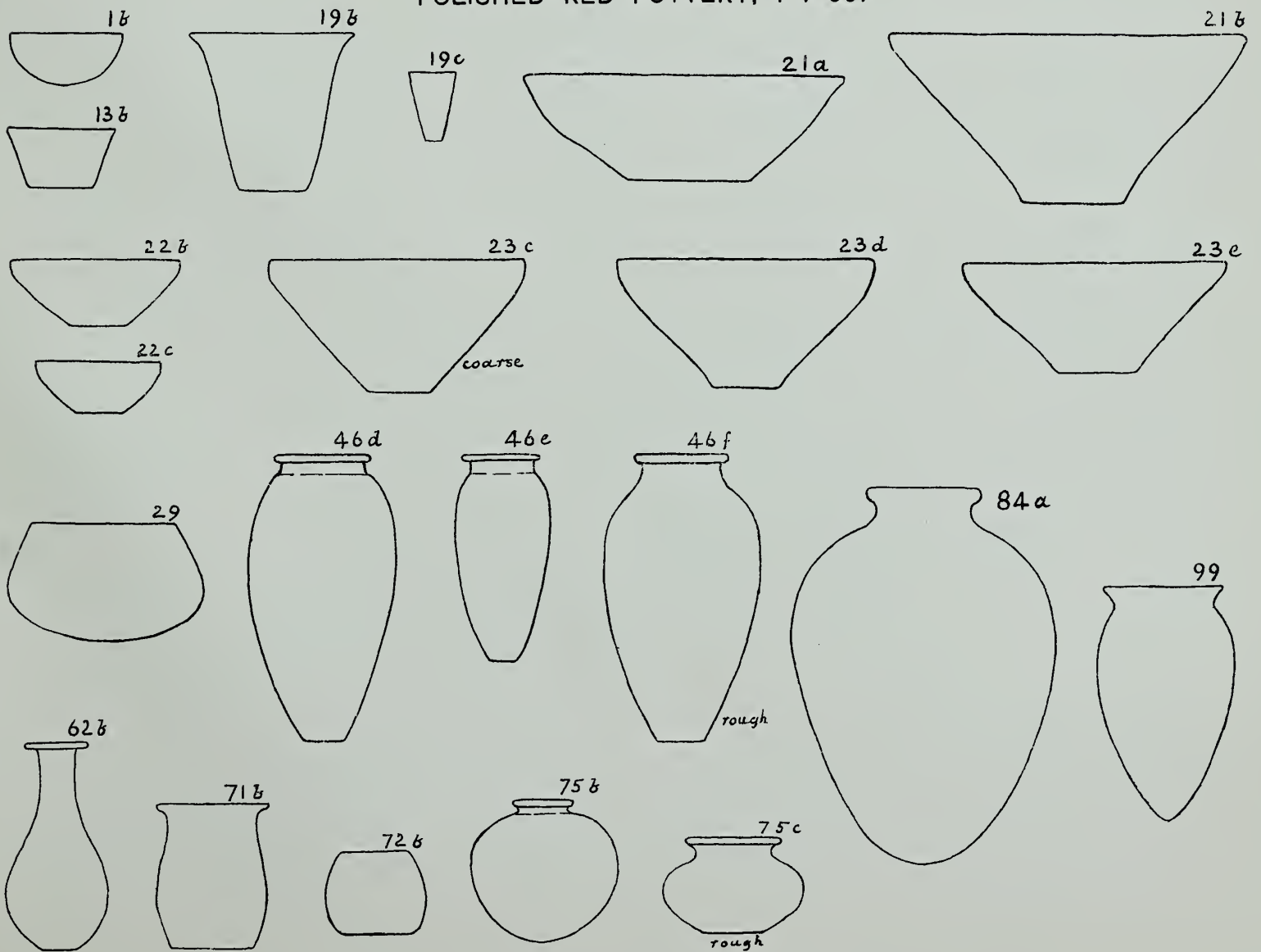

FANCY FORMS OF POTTERY, F.

XIV

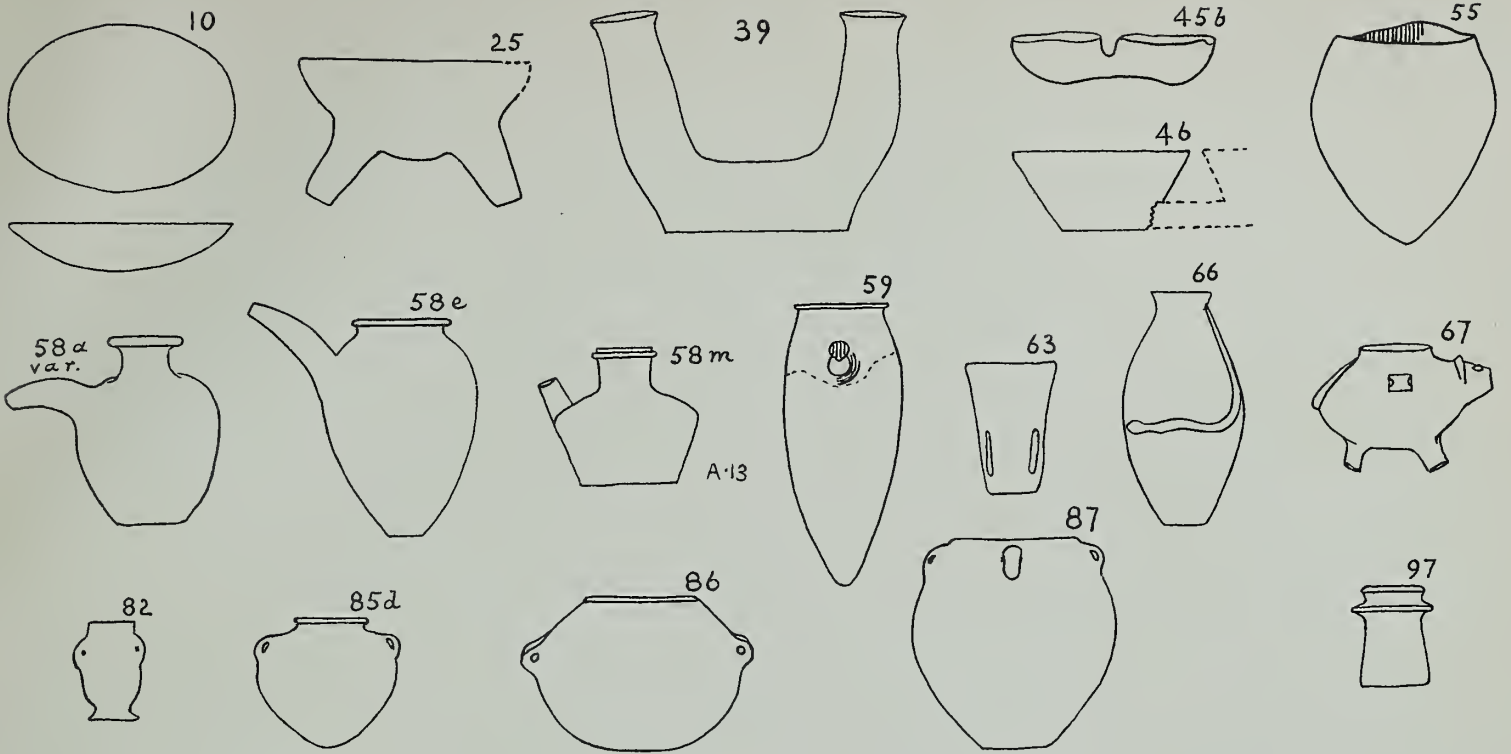

WHITE CROSS-LINED POTTERY, C.

BLACK INCISED, N.



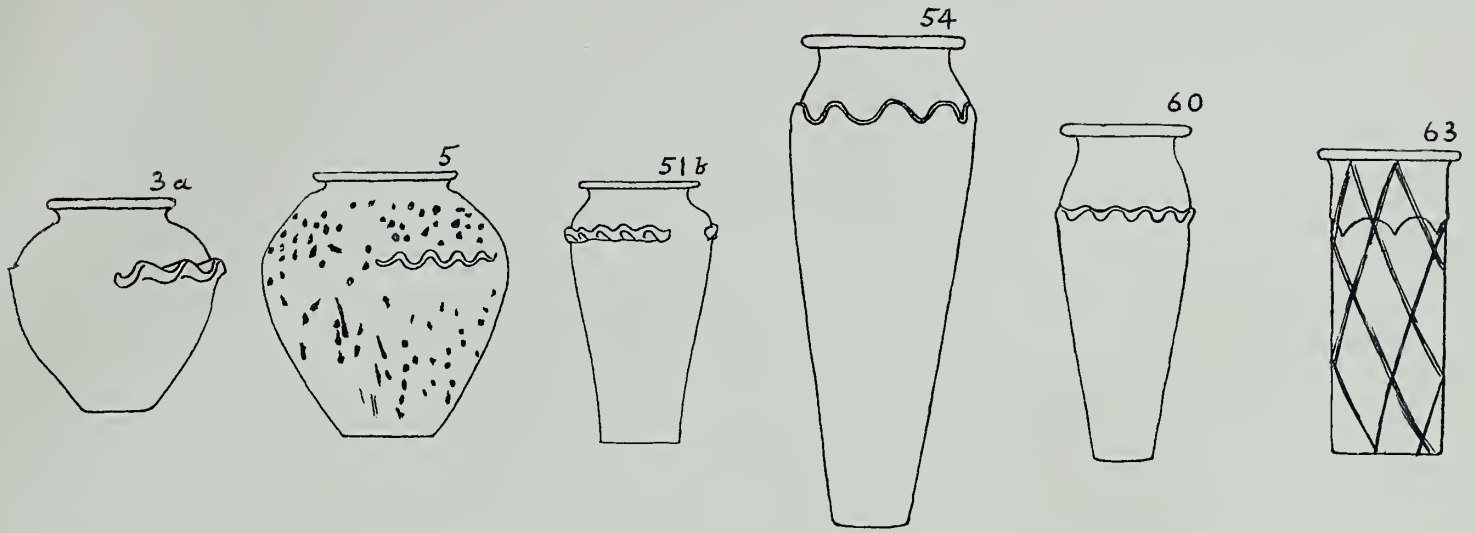

DECORATED POTTERY, D 2-29.

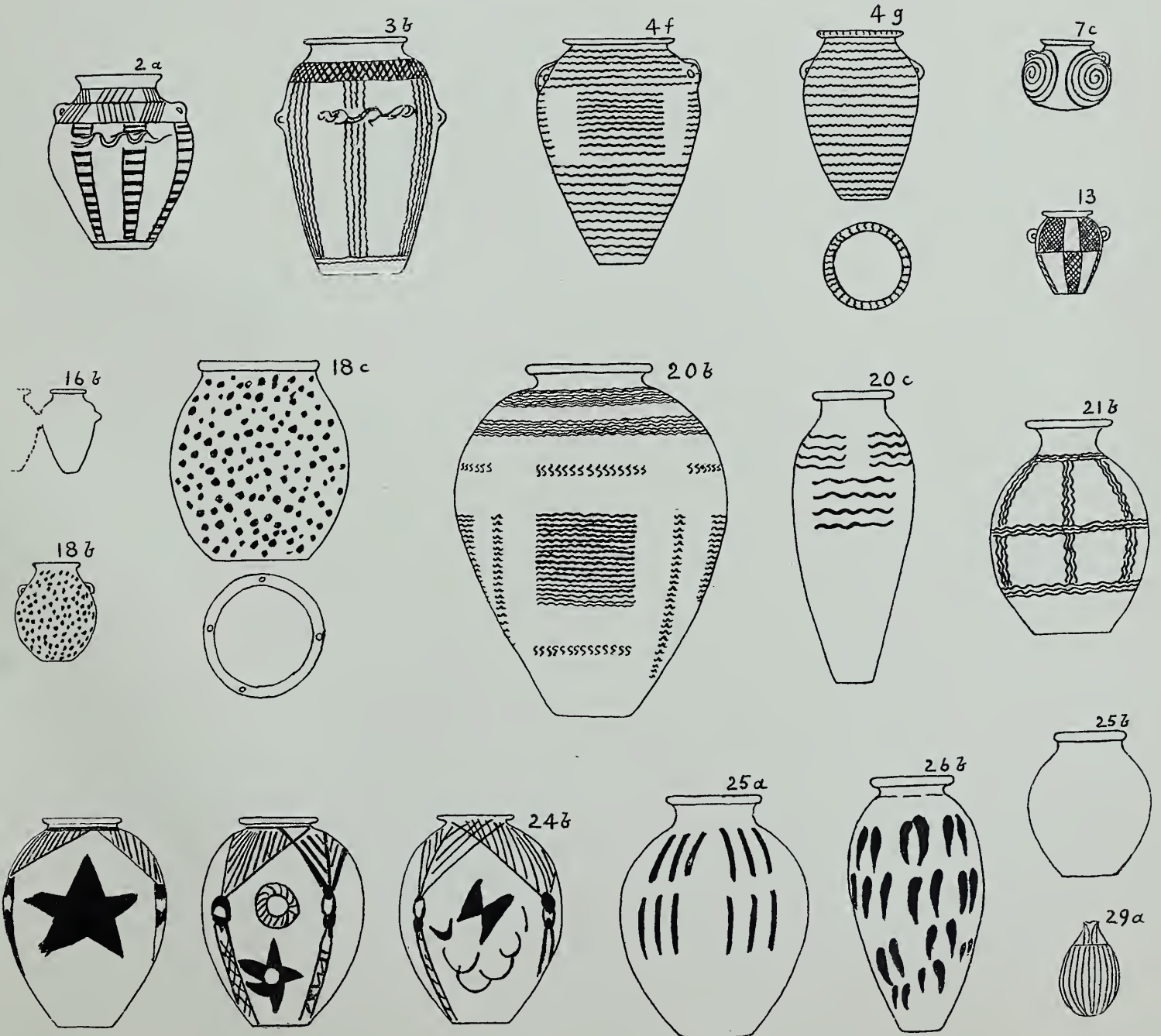

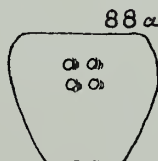
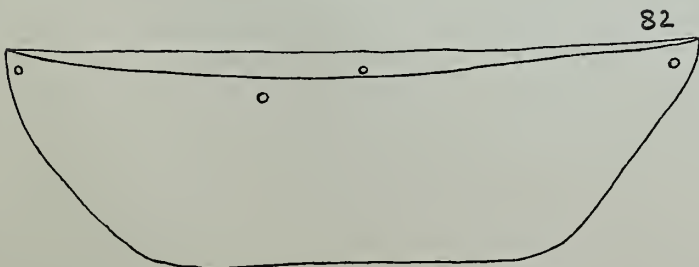
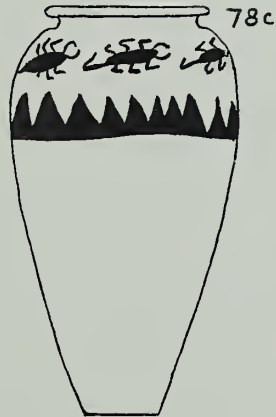
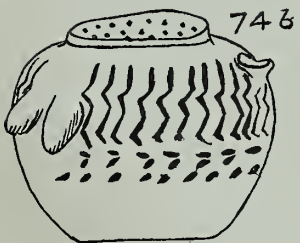
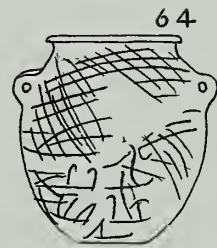
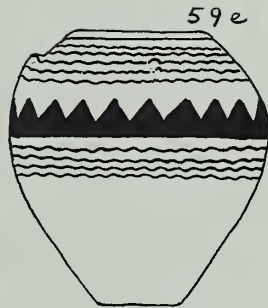
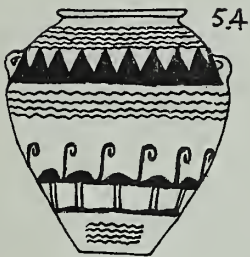
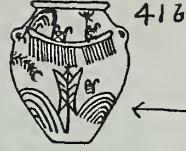
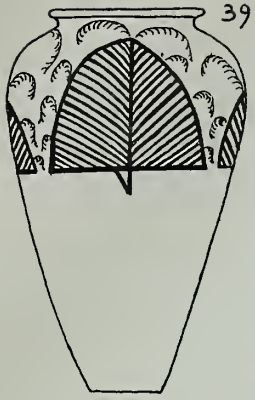

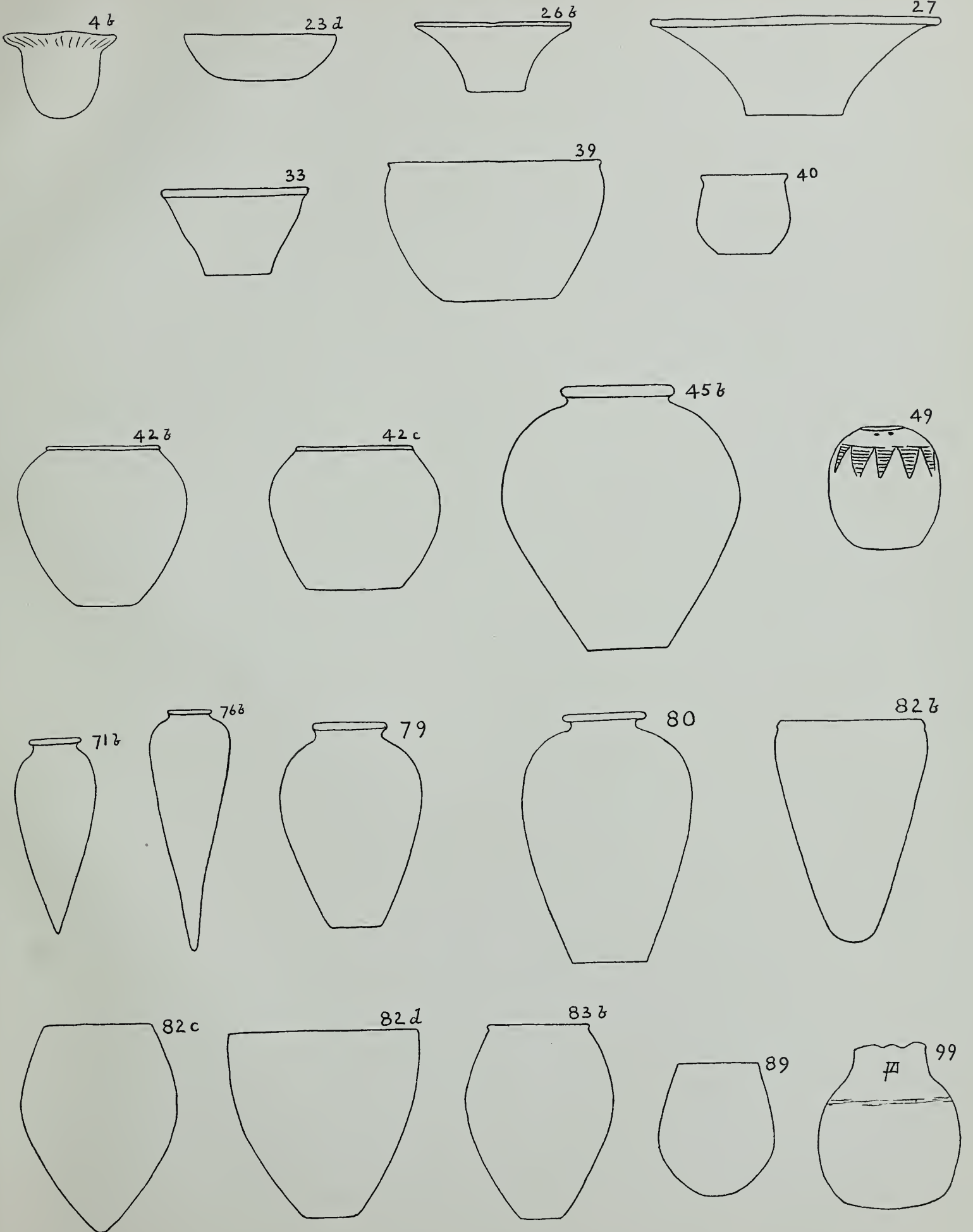

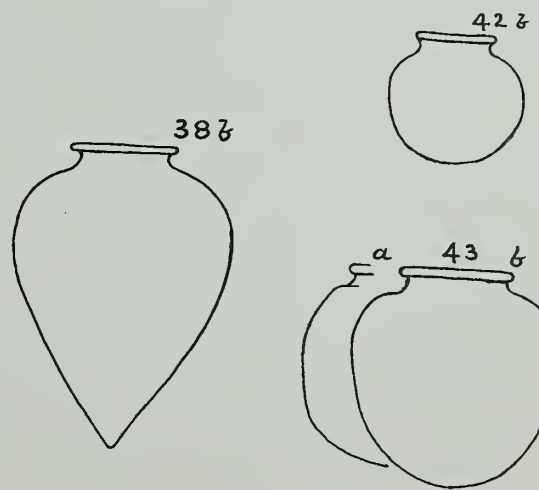
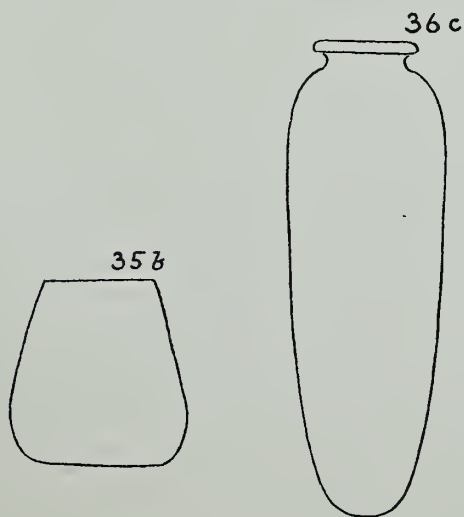
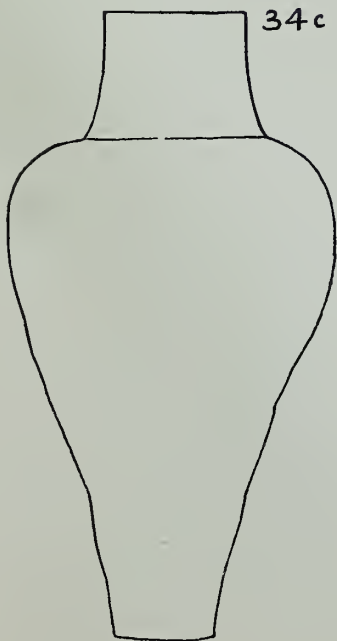
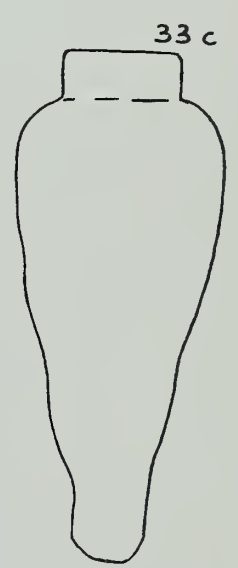
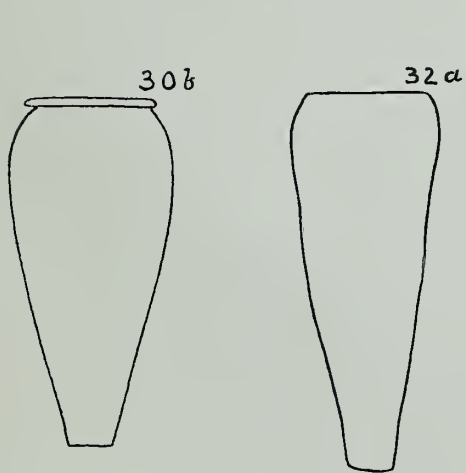
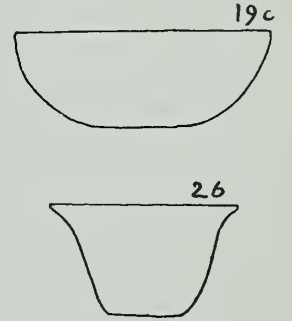
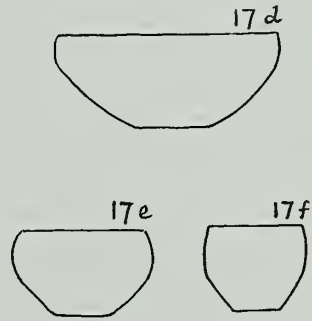
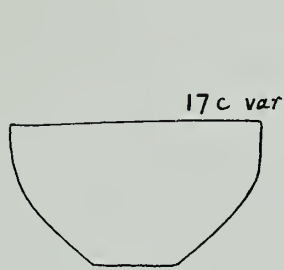
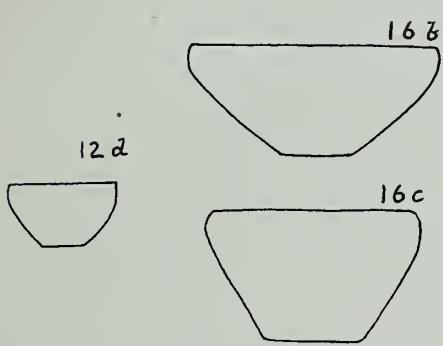
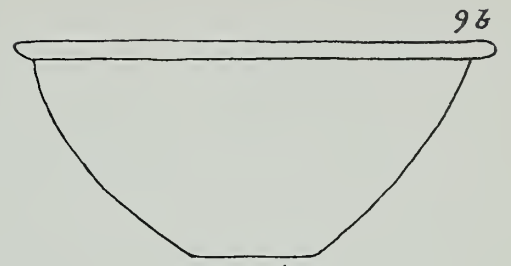
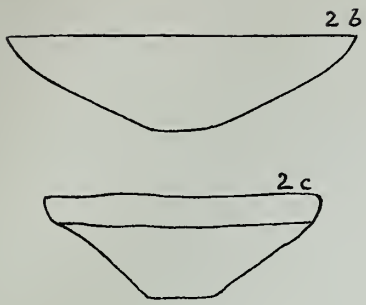

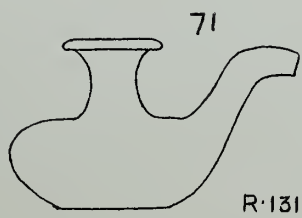
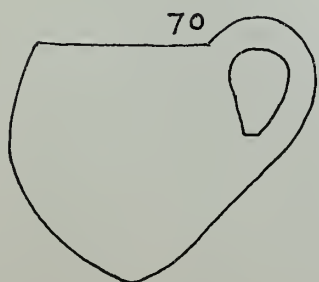
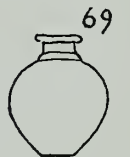
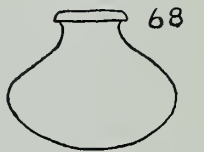
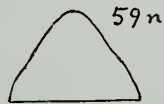
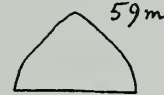
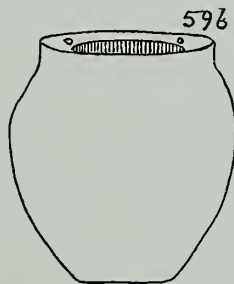
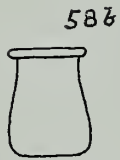
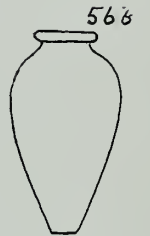
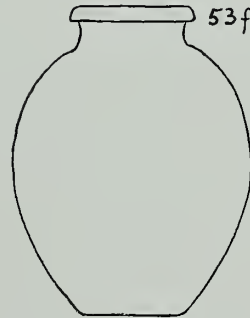
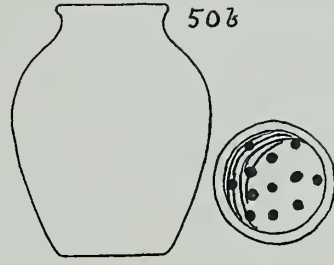
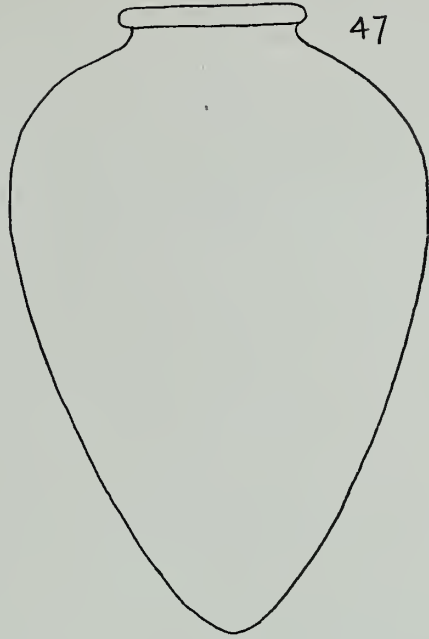
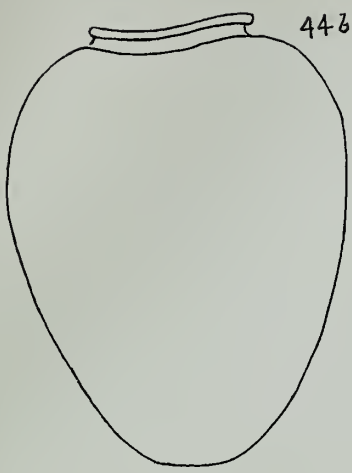

R.131

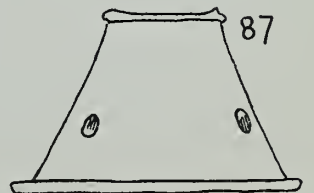
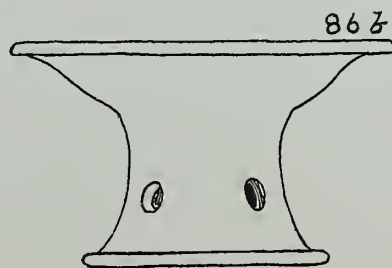

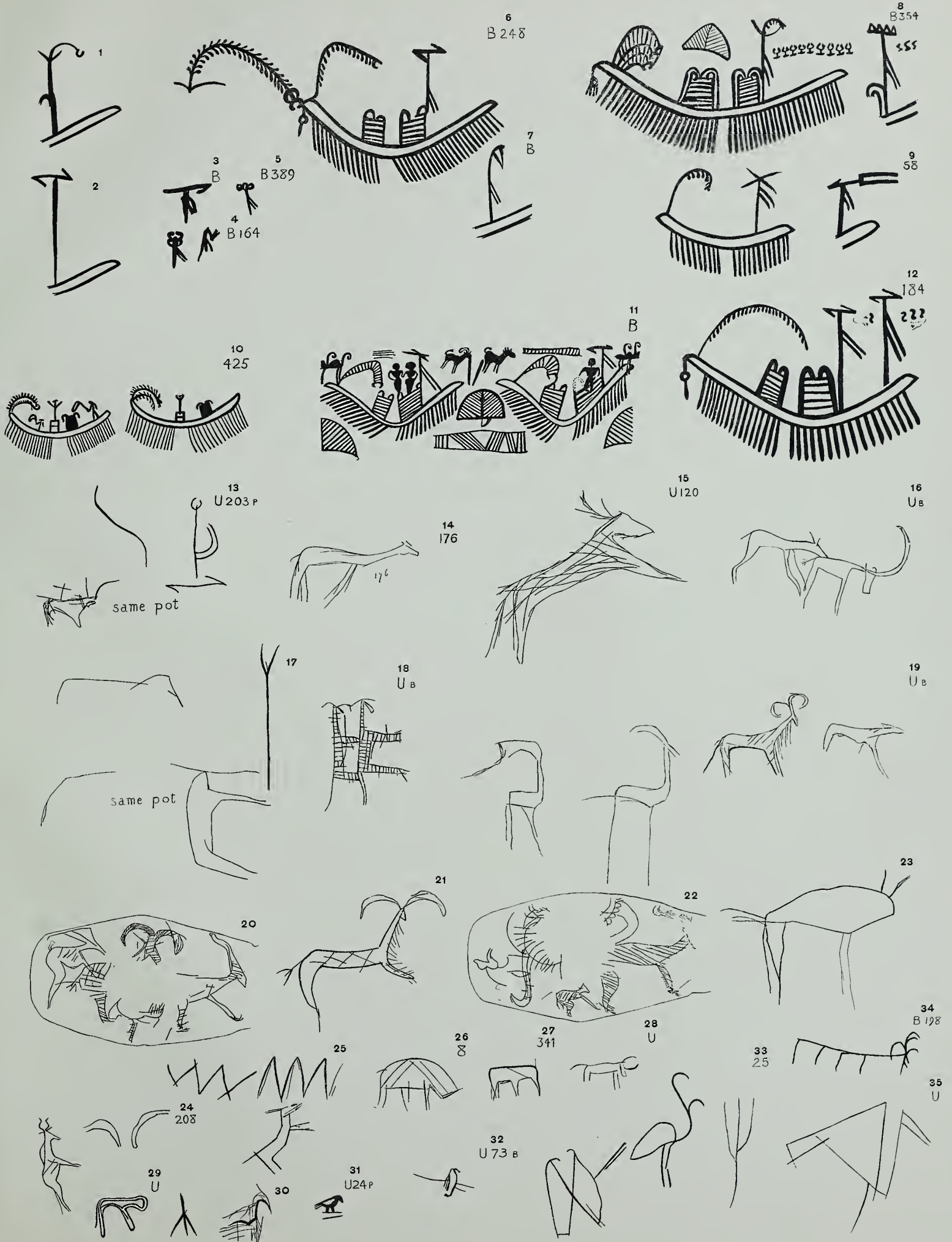

DIOSPOLIS. PREHISTORIC MARKS.

1:4

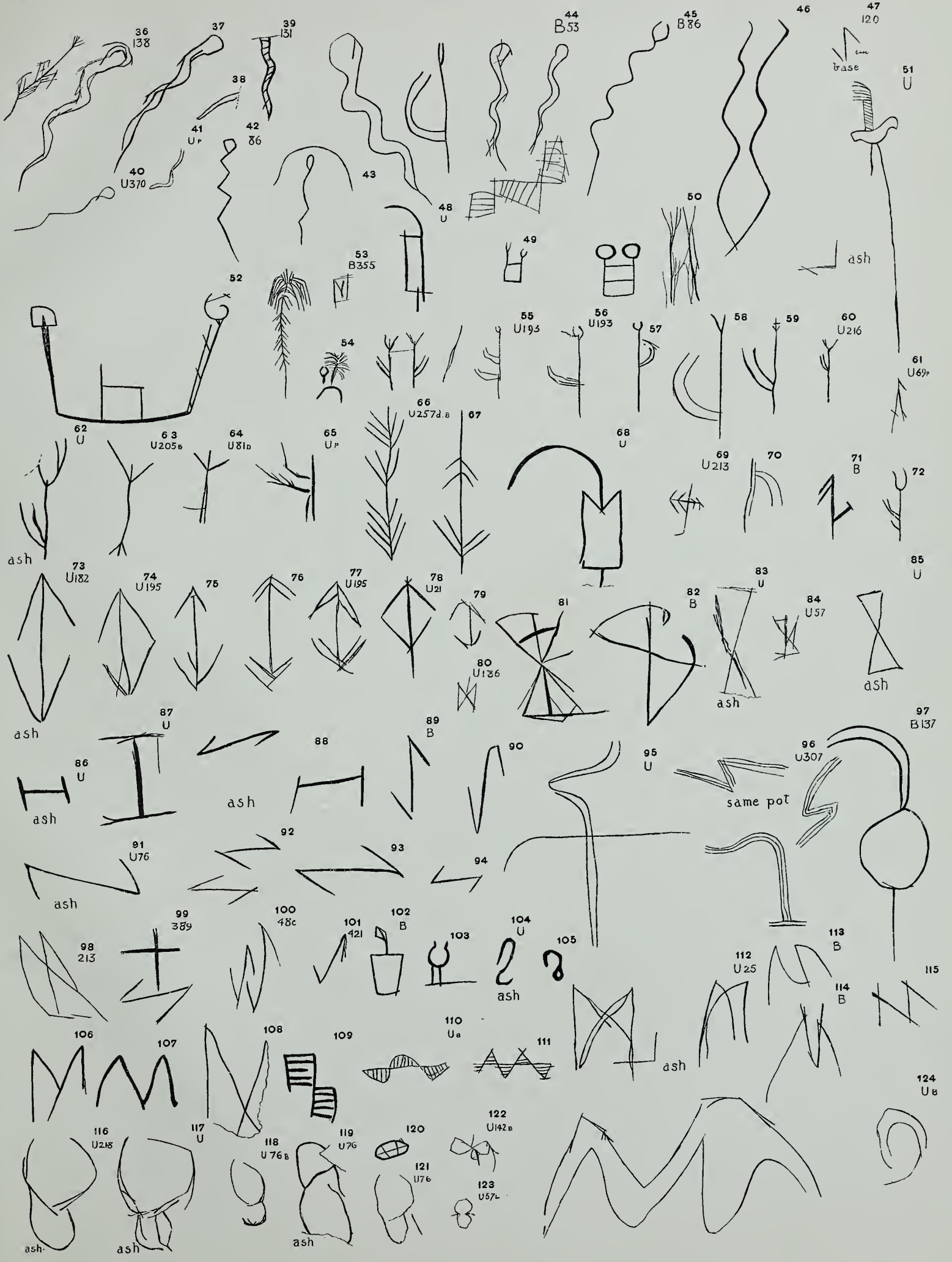

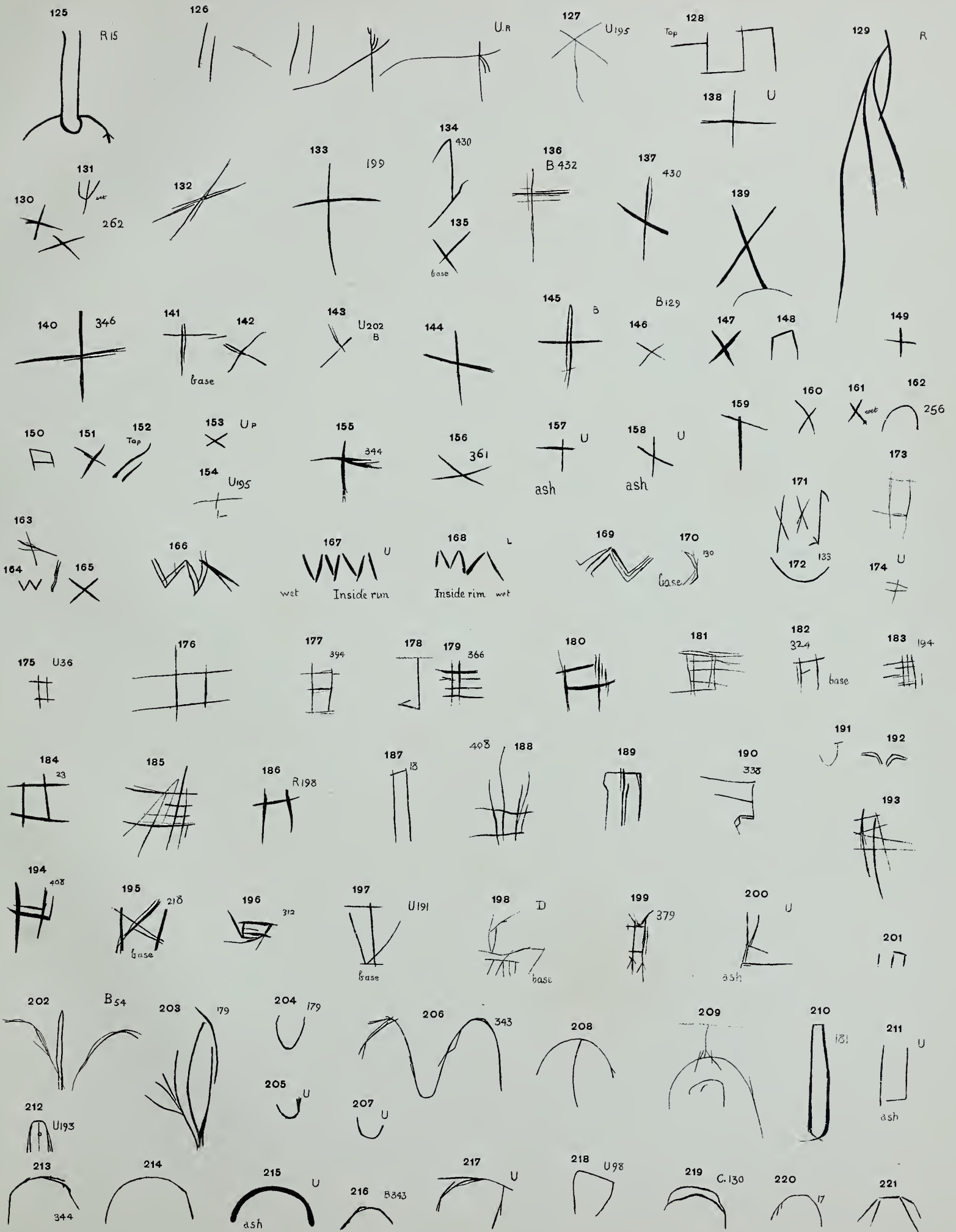

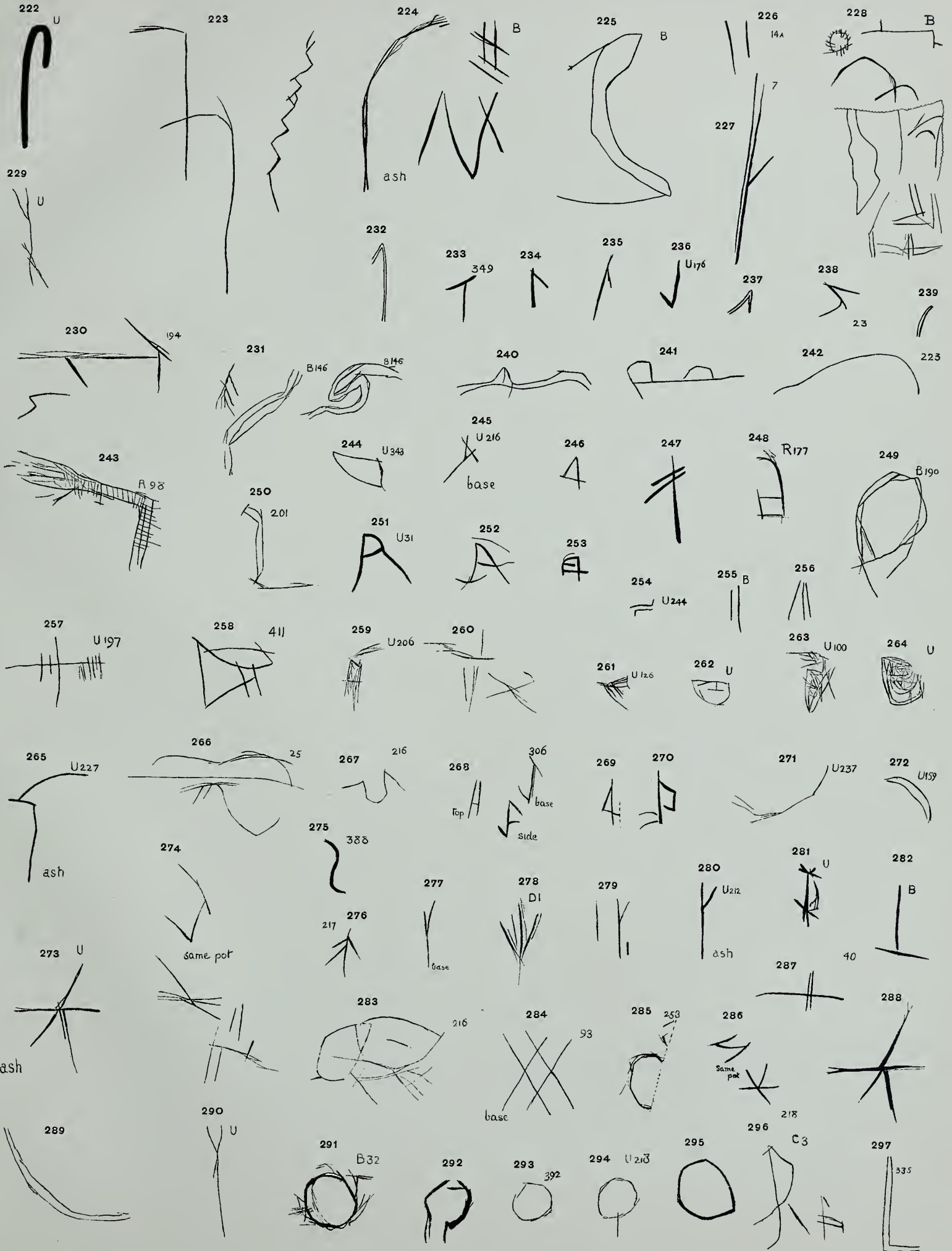

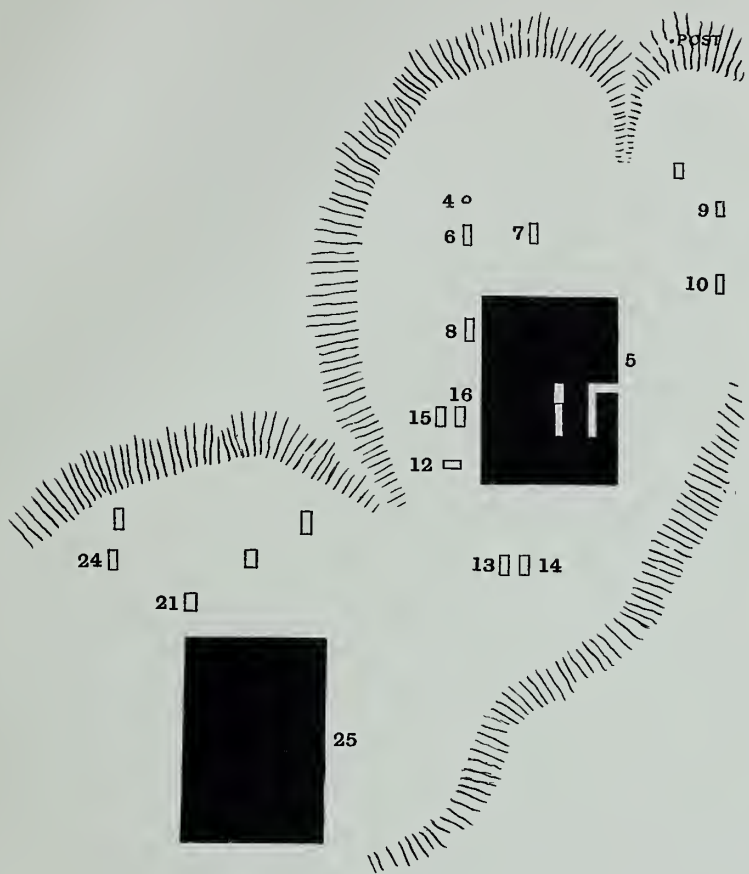

1:200

MASTABA D 5.

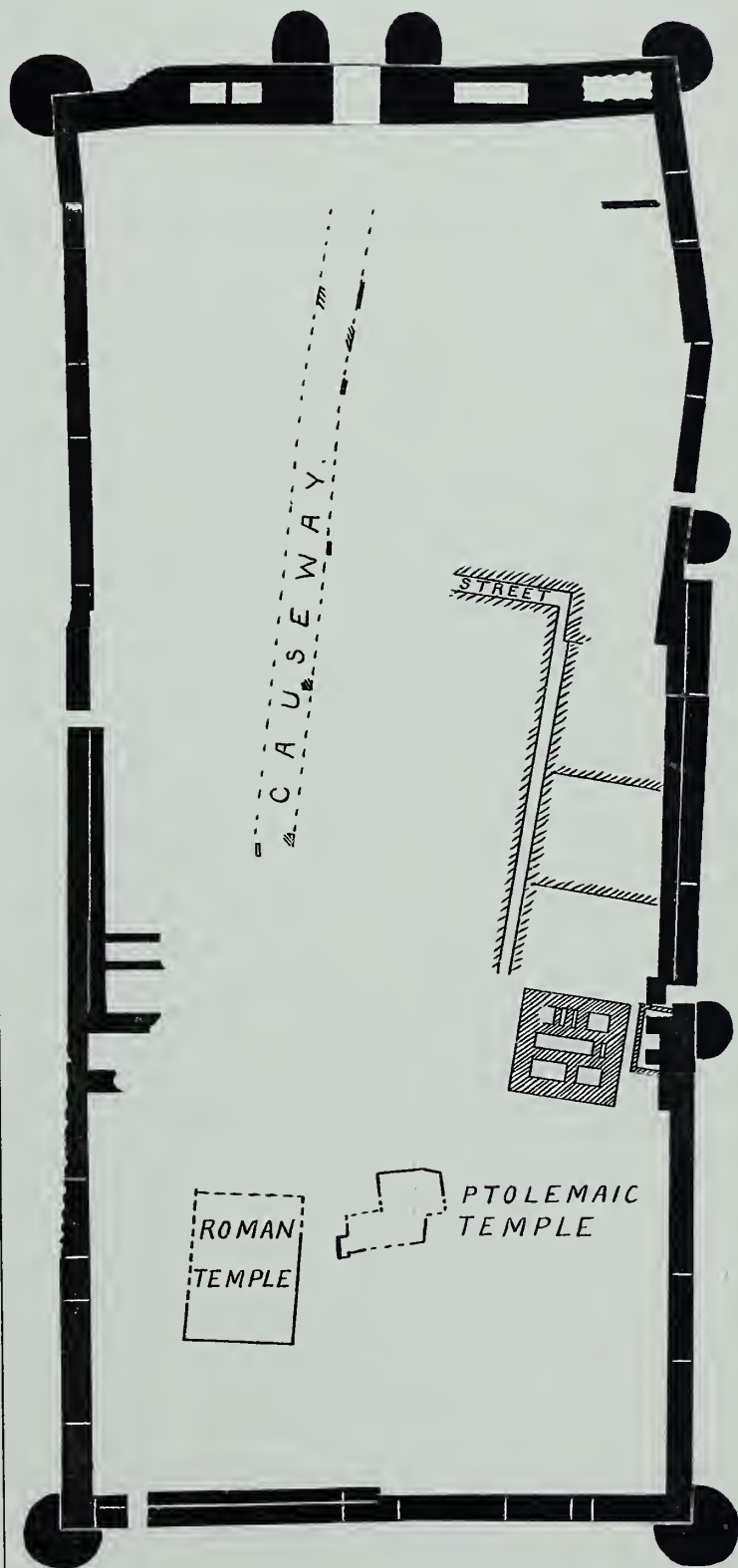

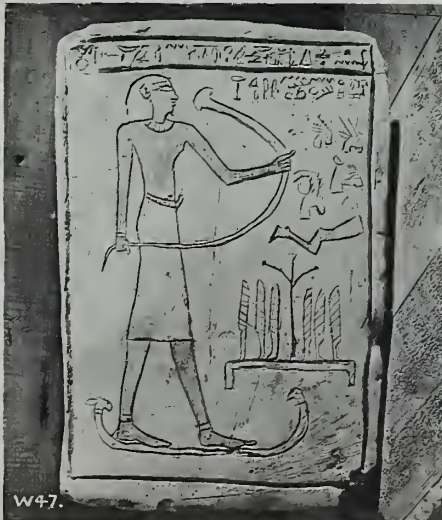
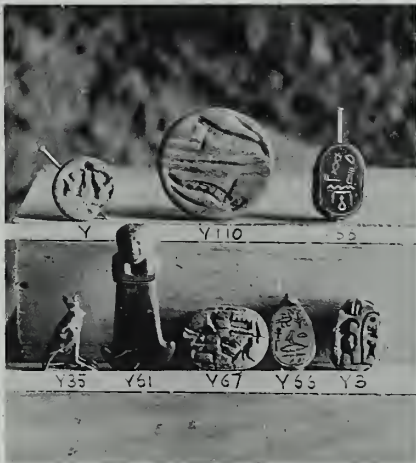
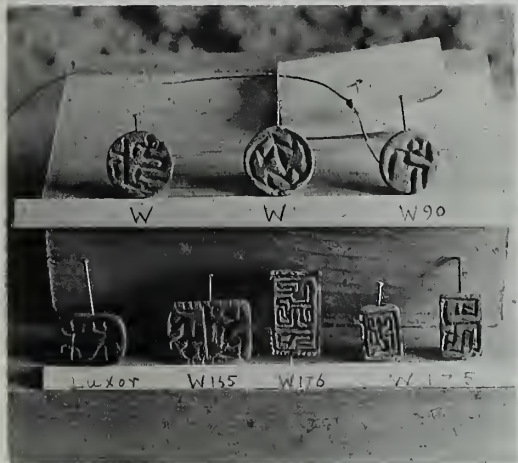

NEKHTYK.

HOTEPAQERA.

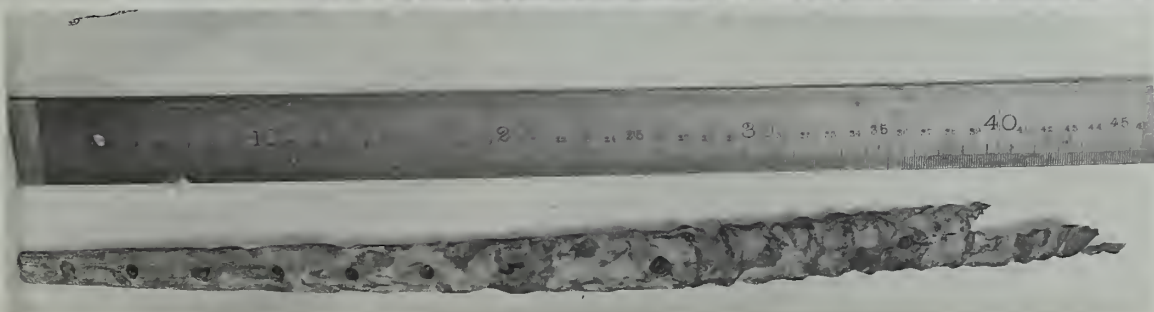



W 32.



W 38.

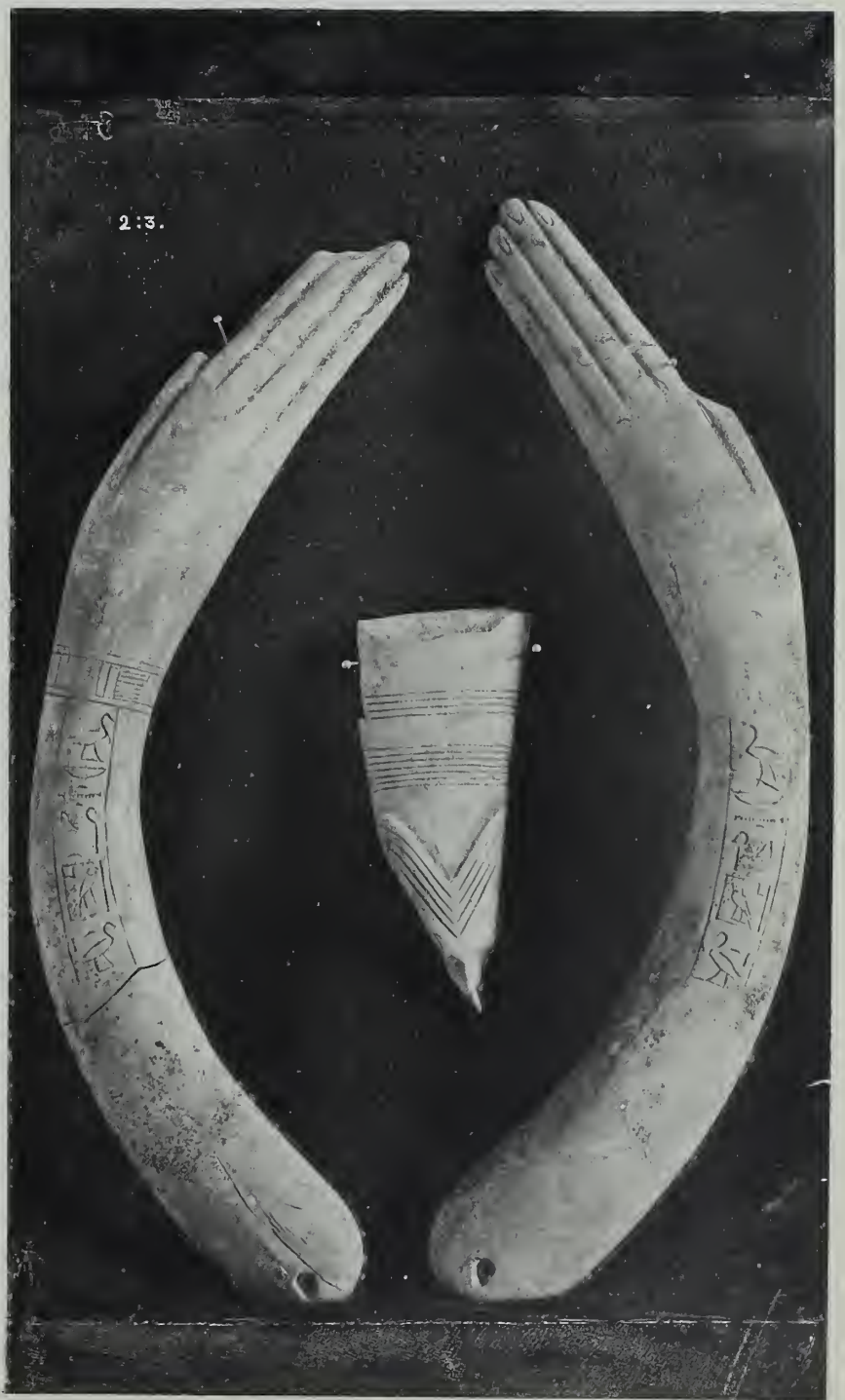

2:3.

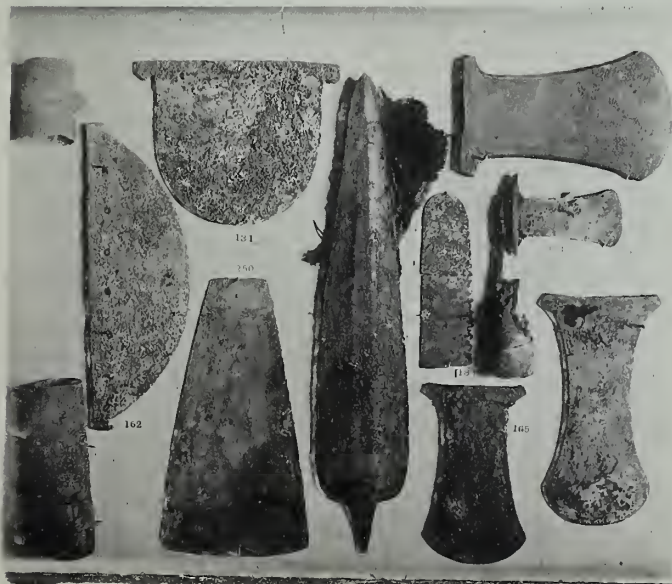

162

161

160

159

165

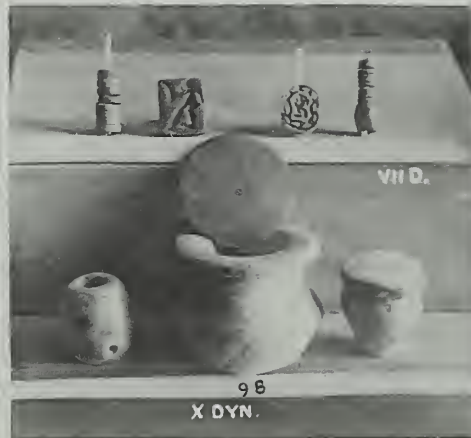
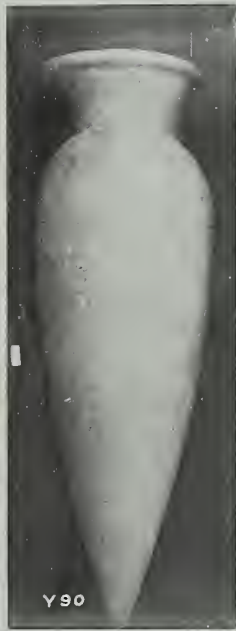
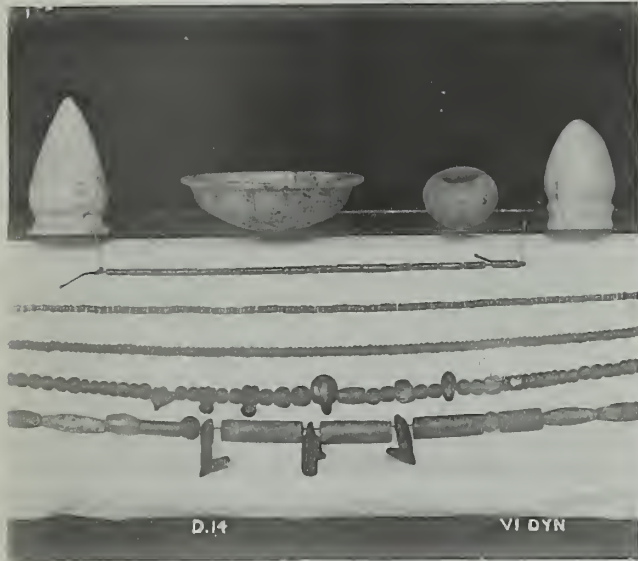

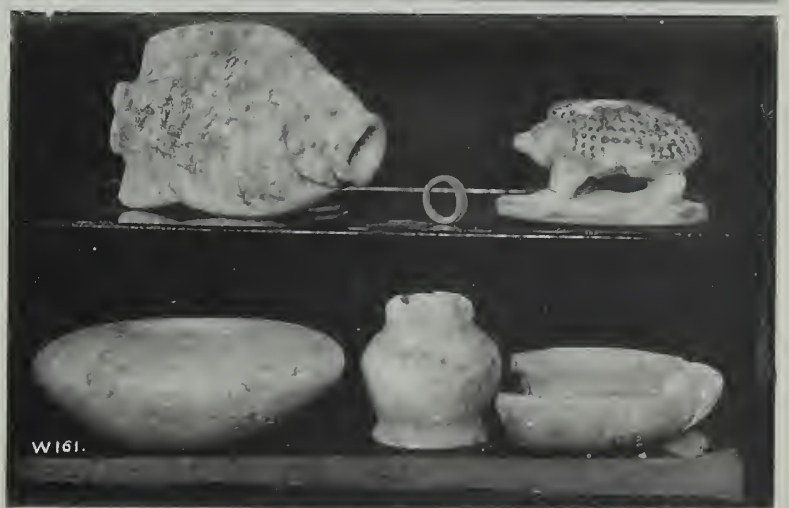
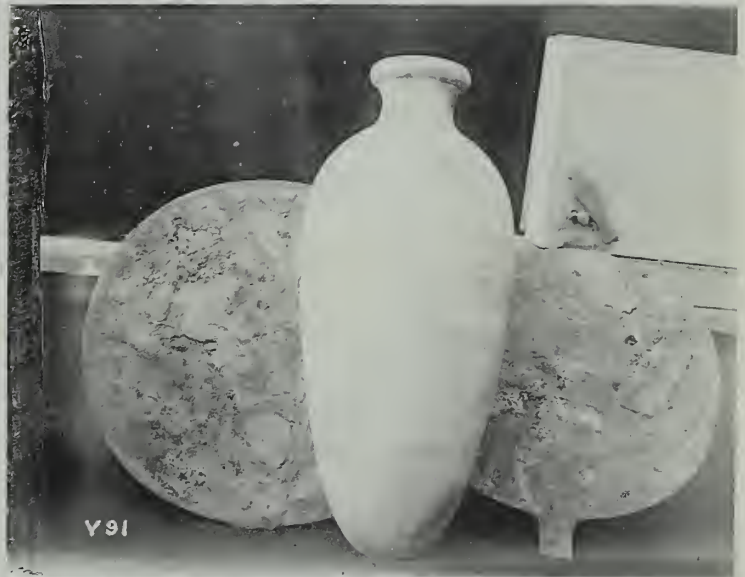
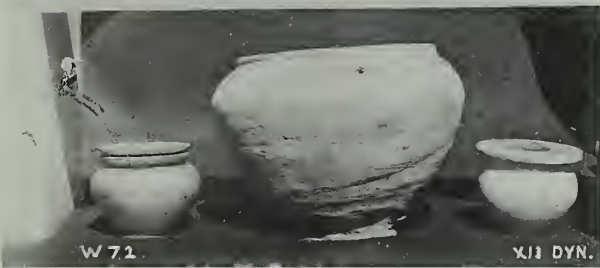
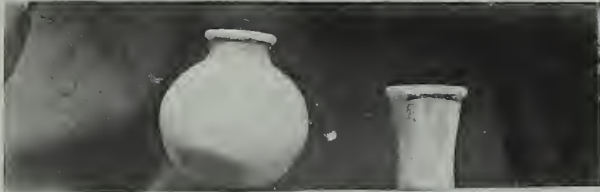

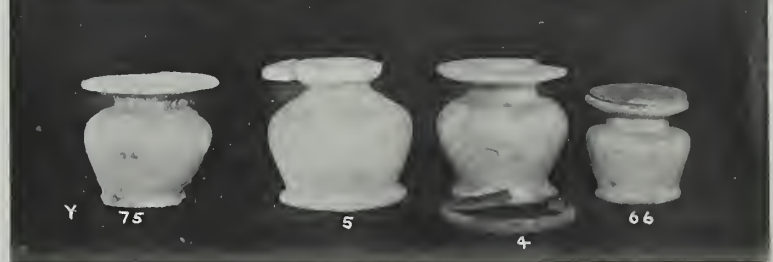

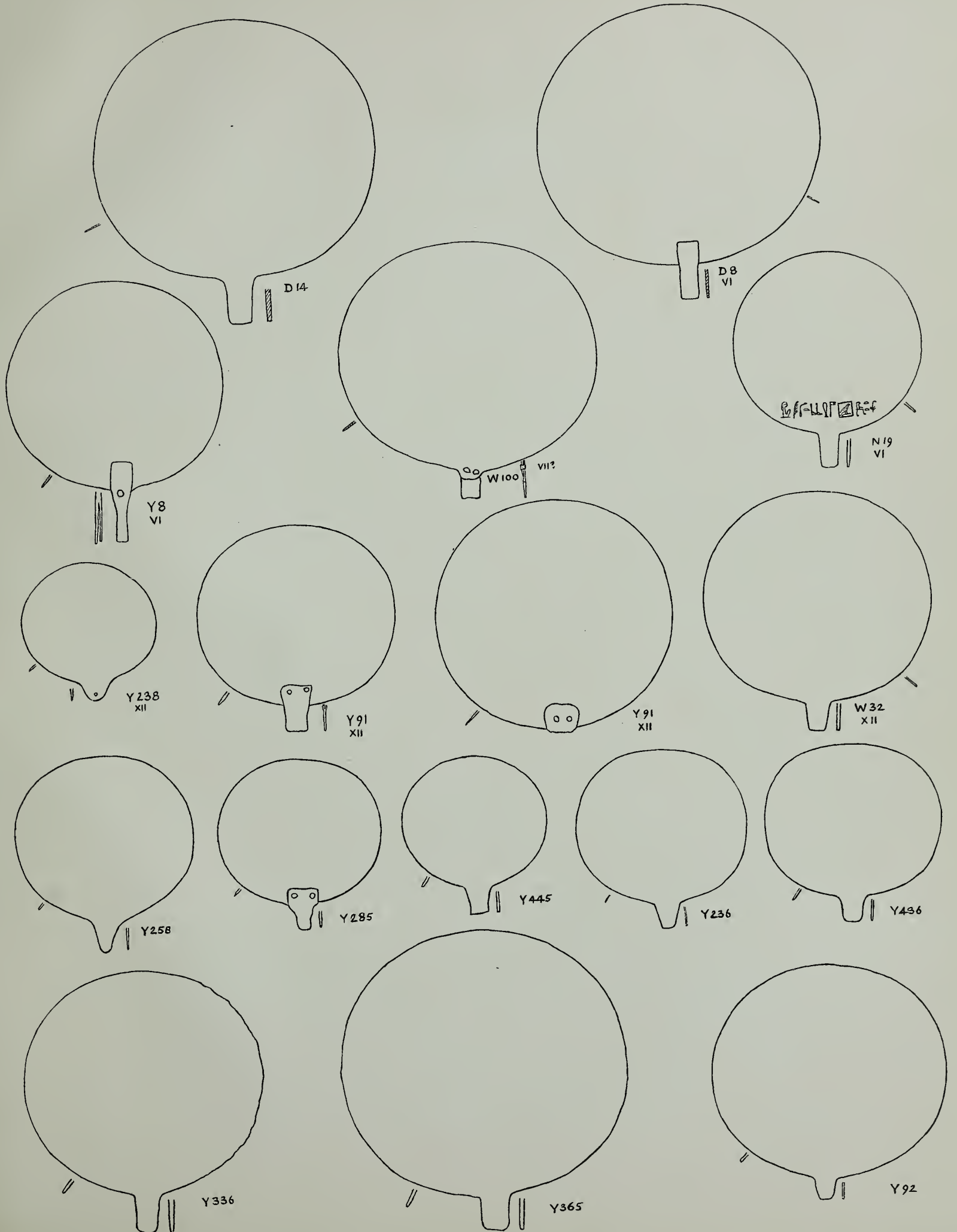

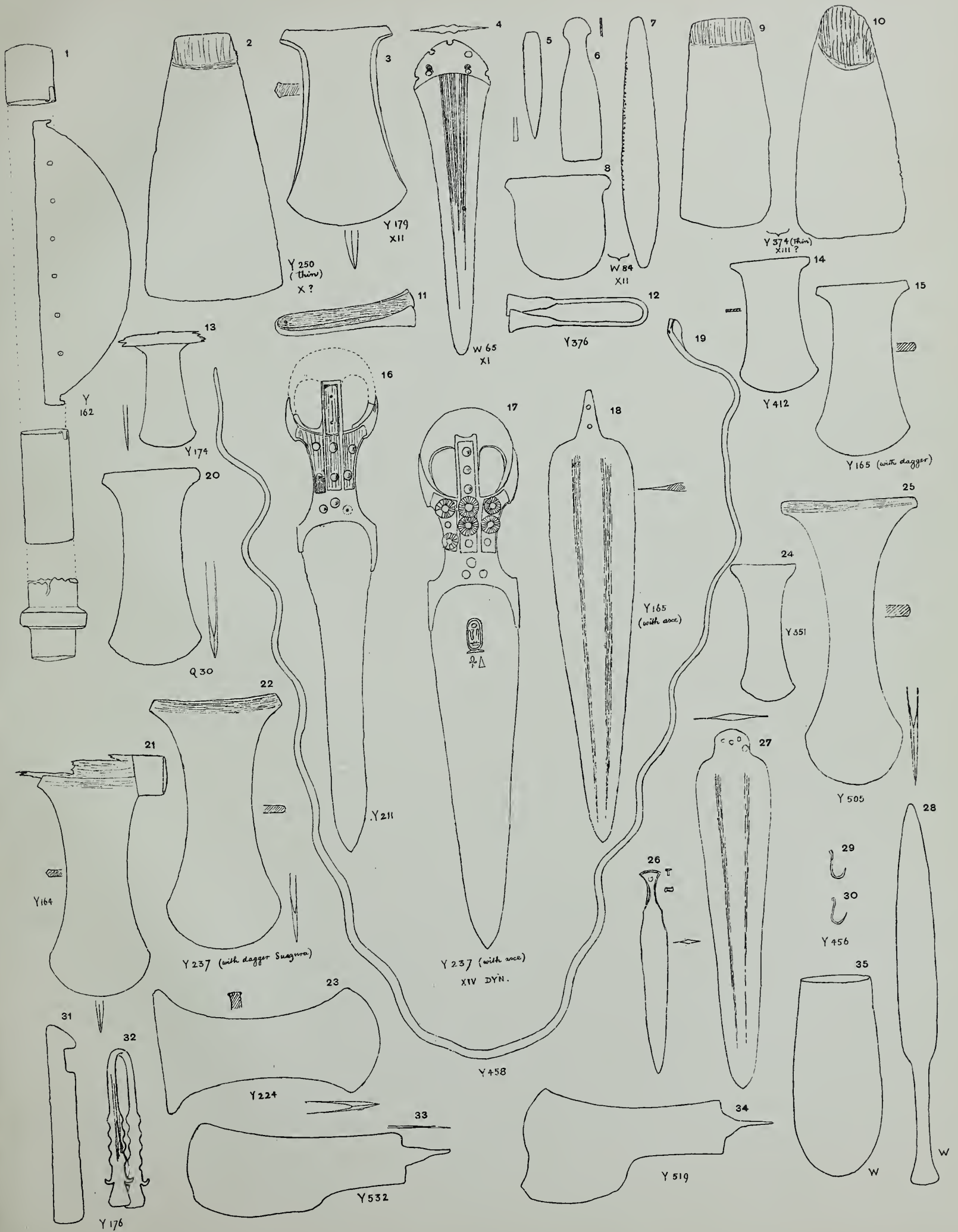

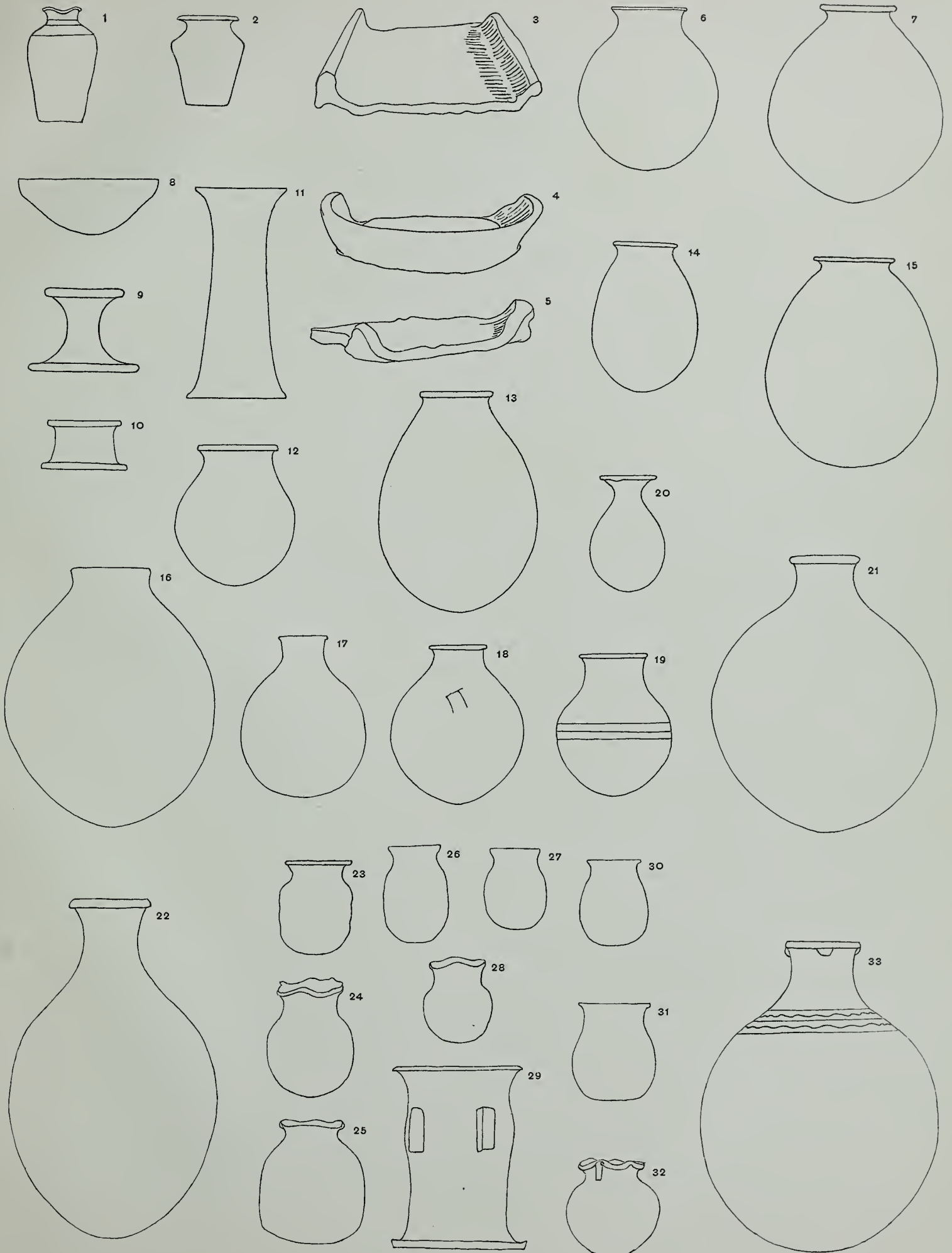



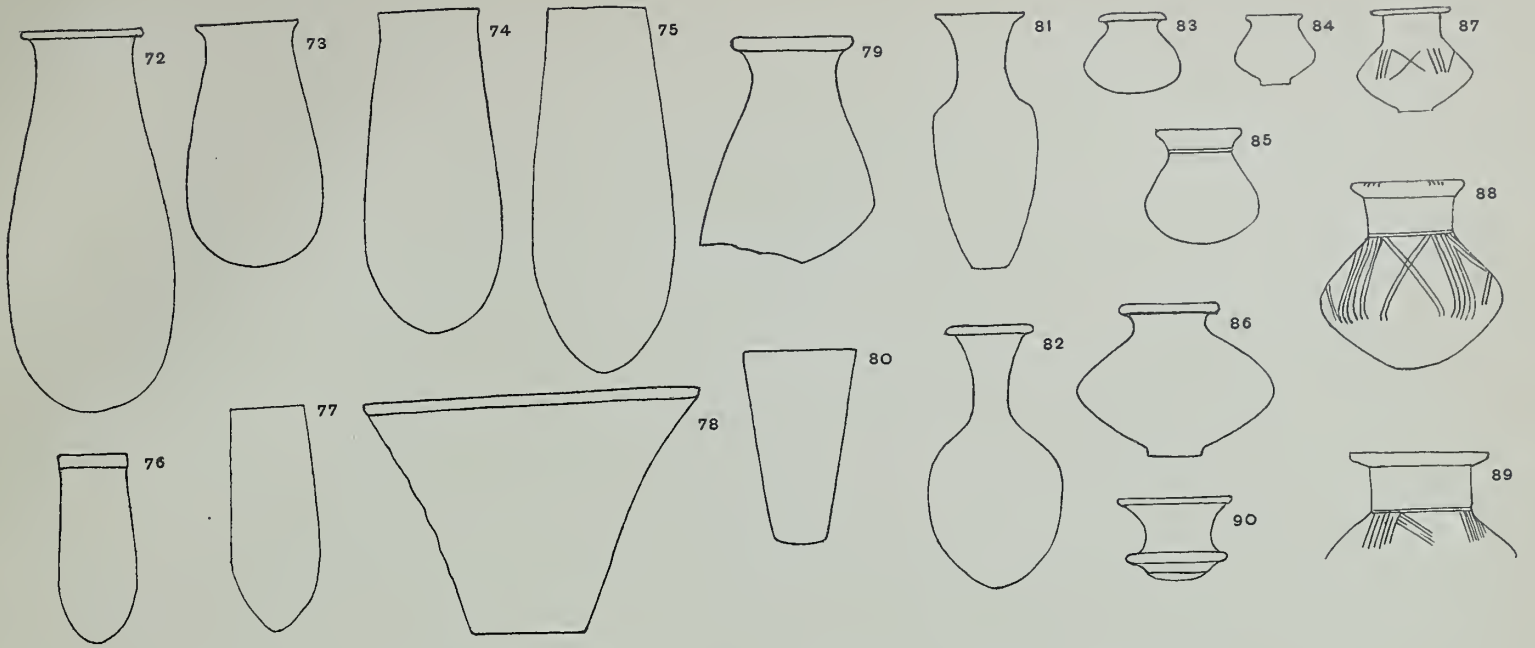

HU. POTTERY, XII-XVIII DYNASTY, CEMETERY Y S.

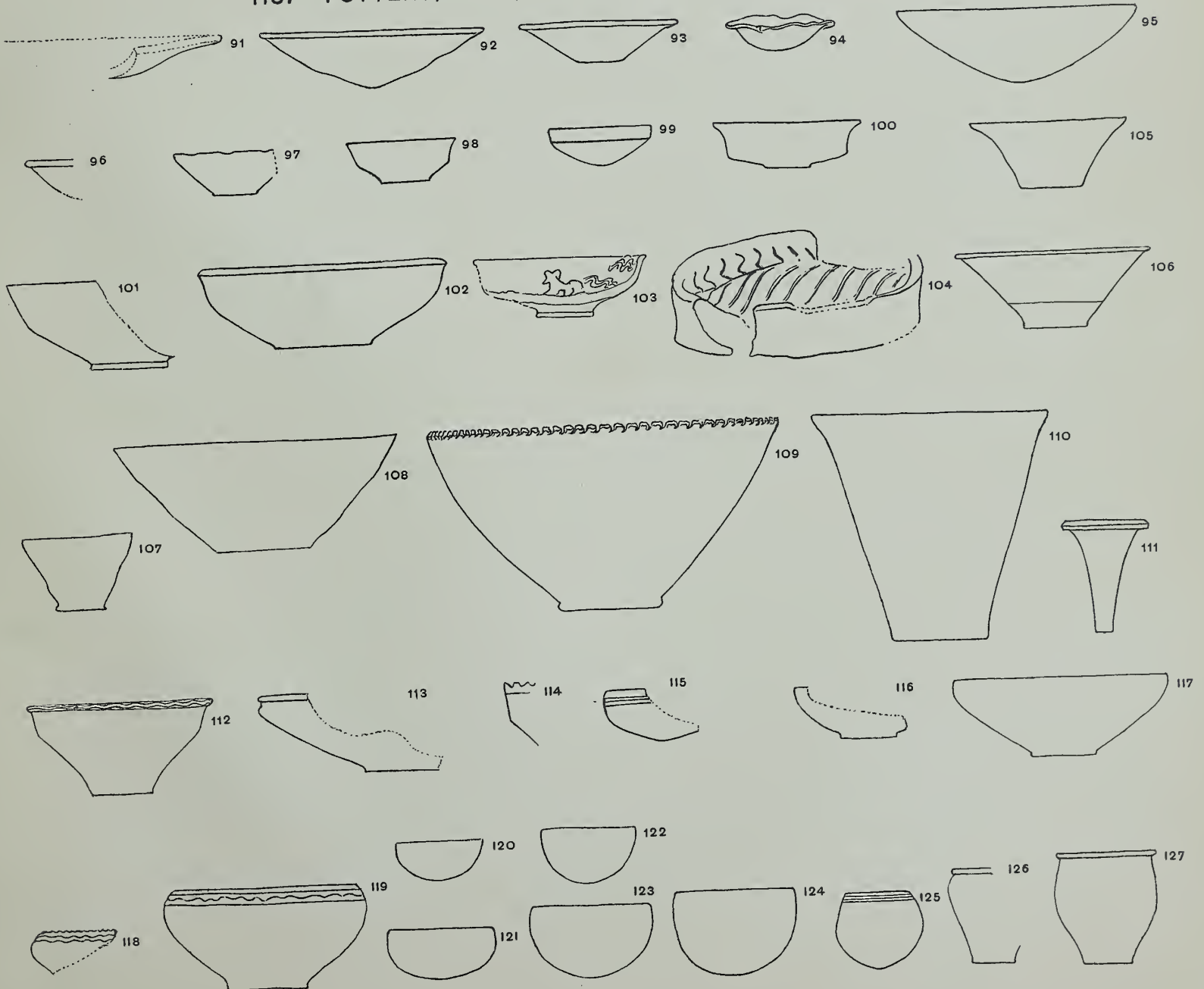

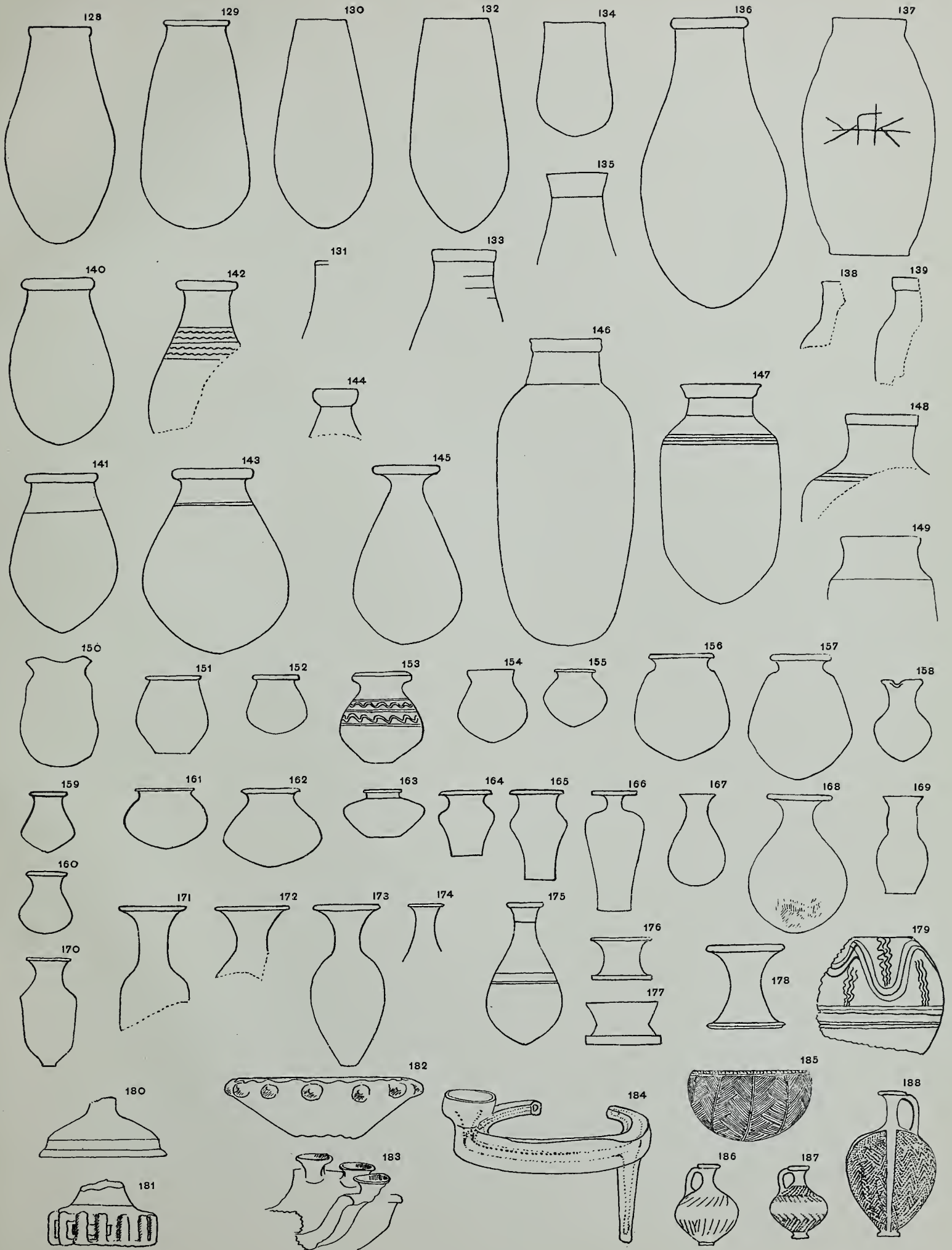

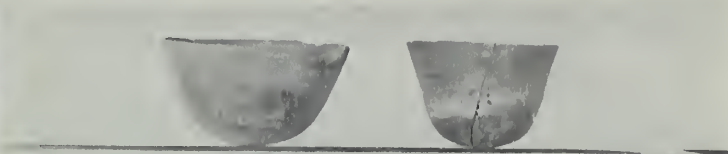
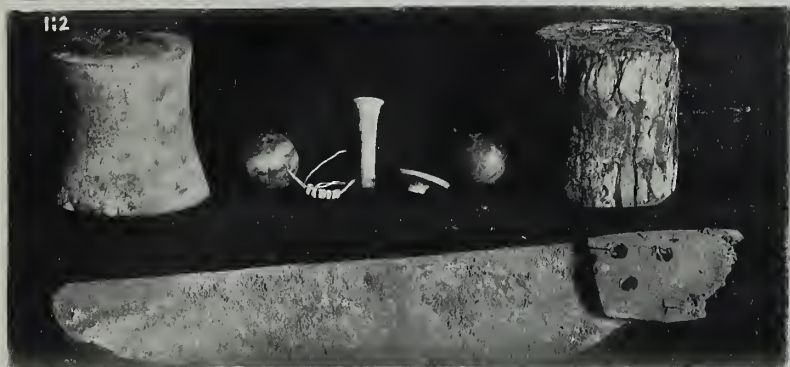

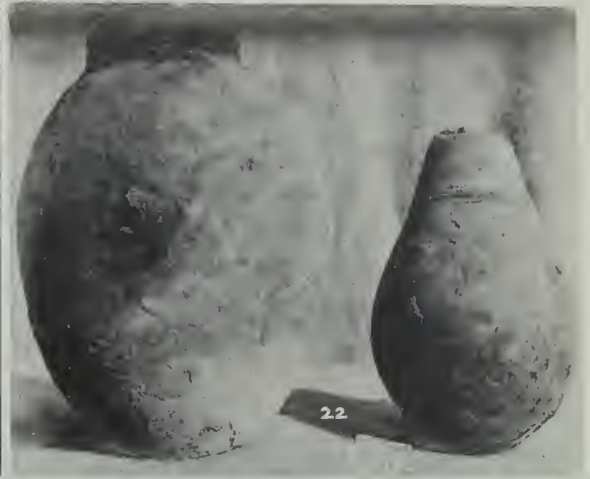
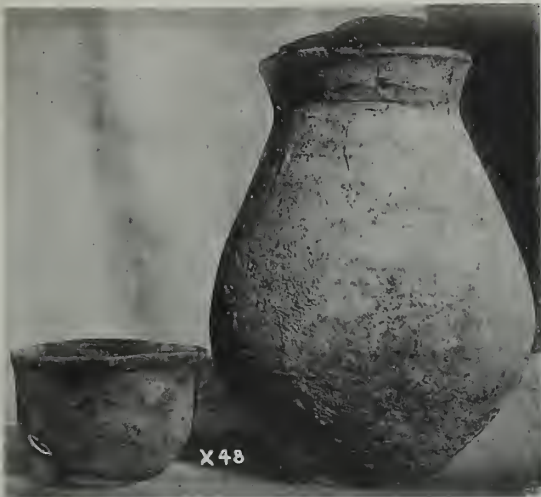

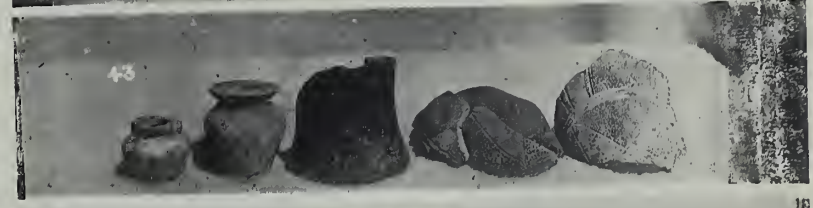



GOLD PLATE ON AMETHYST Y.428

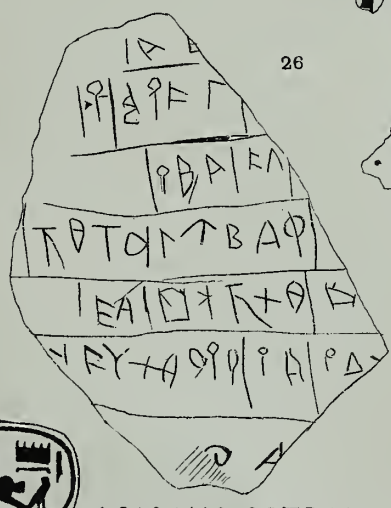

ASIANIC OSTRAKON.

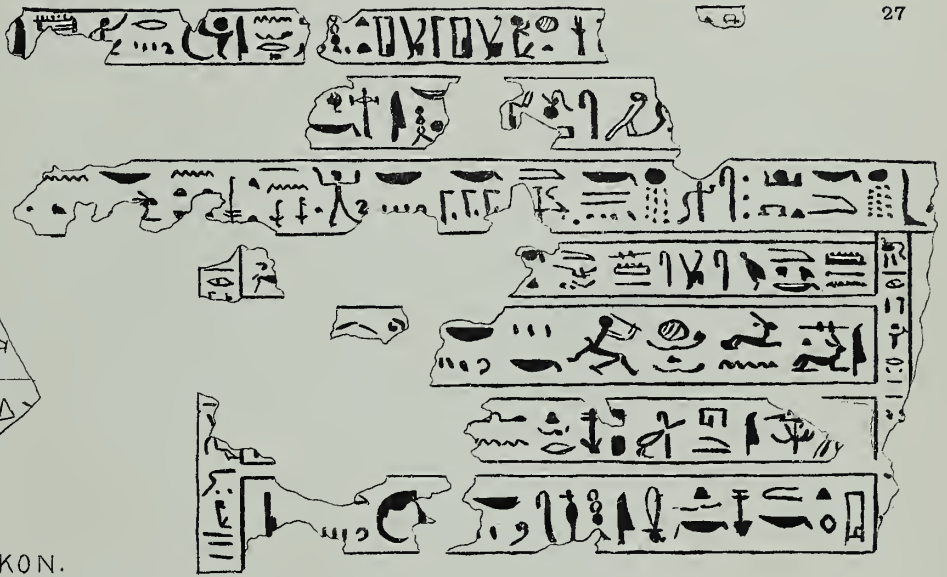

PAINTED WOODEN STELE
CARTONNAGE OF HANEFERI



28

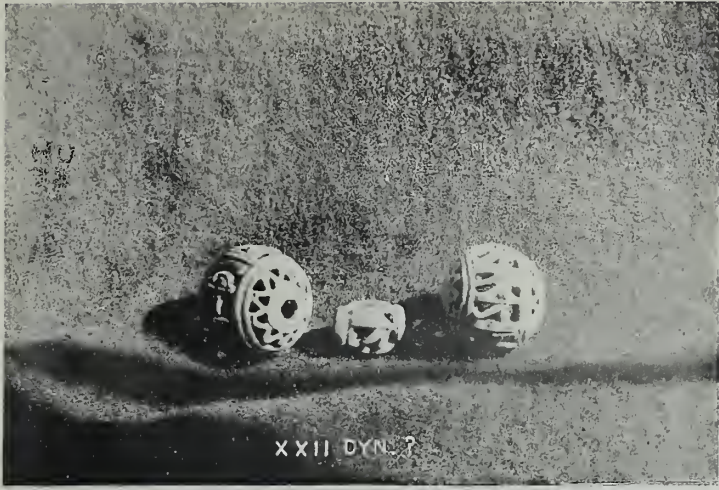

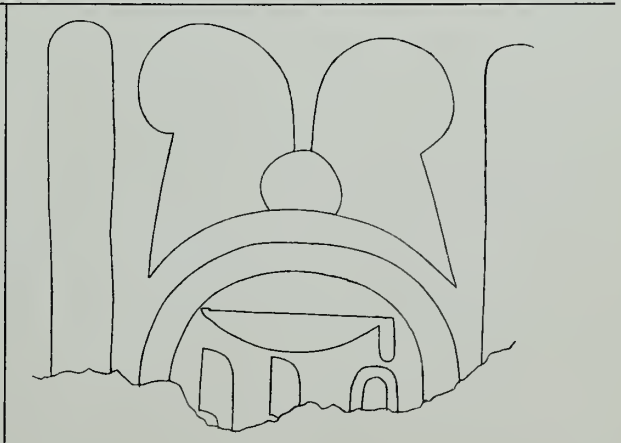
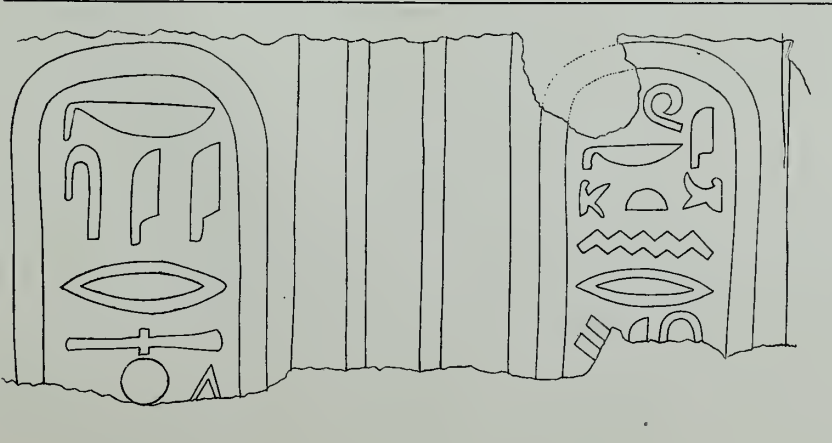
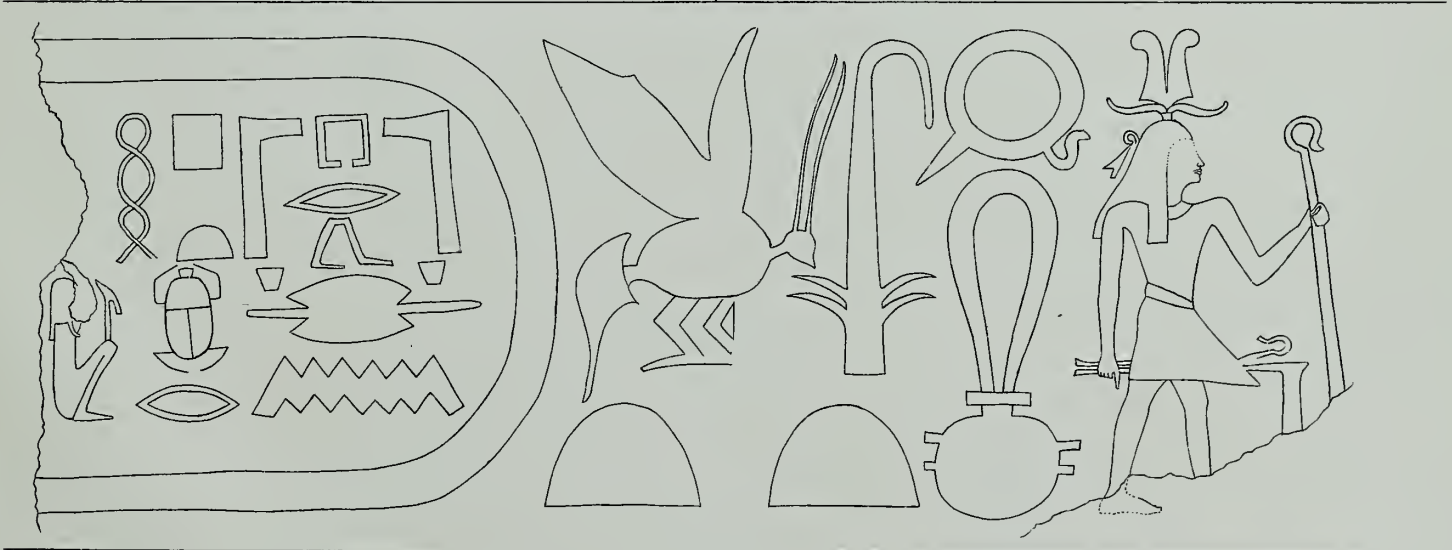
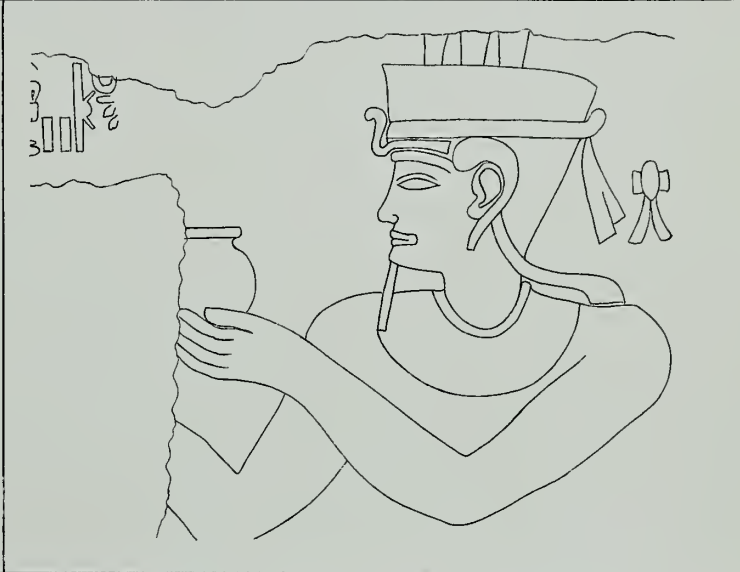
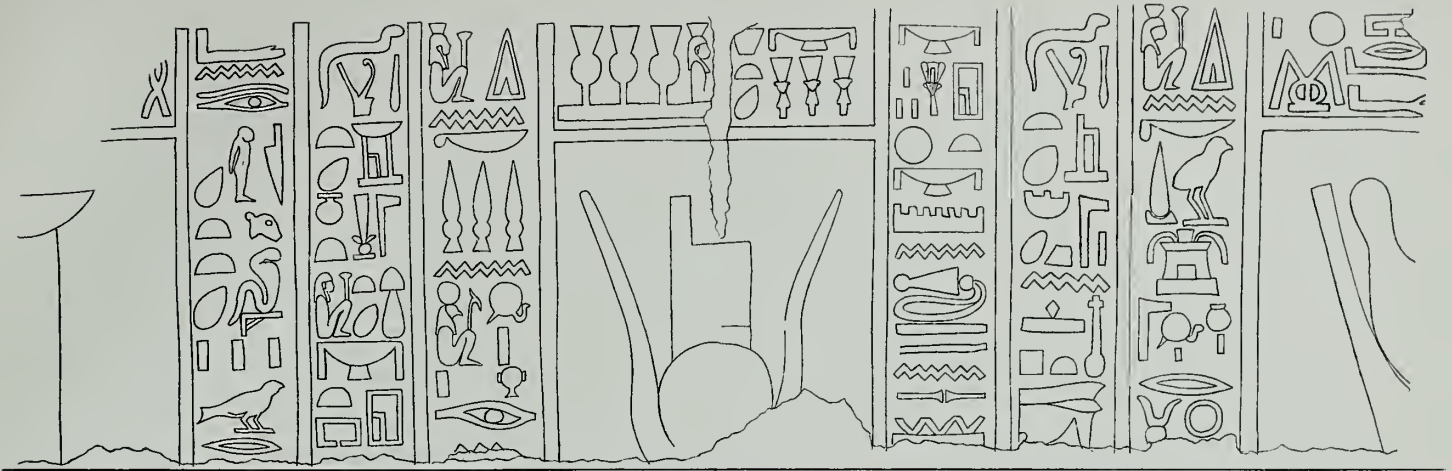

1
 Behind of E'wni
 T=HND
 2
 3
 4
 5
 6
 7
 8
 9
 10
 11
 12

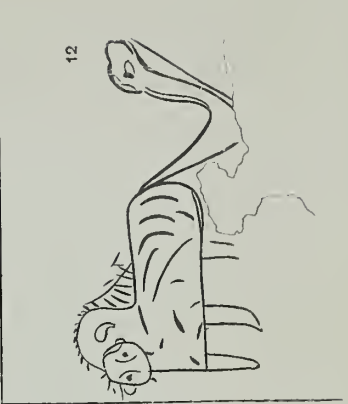
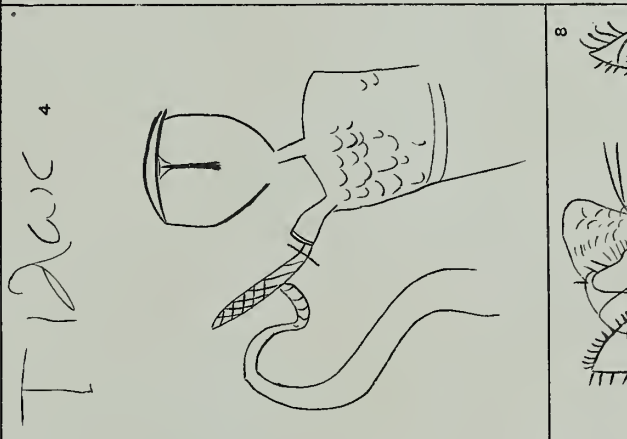
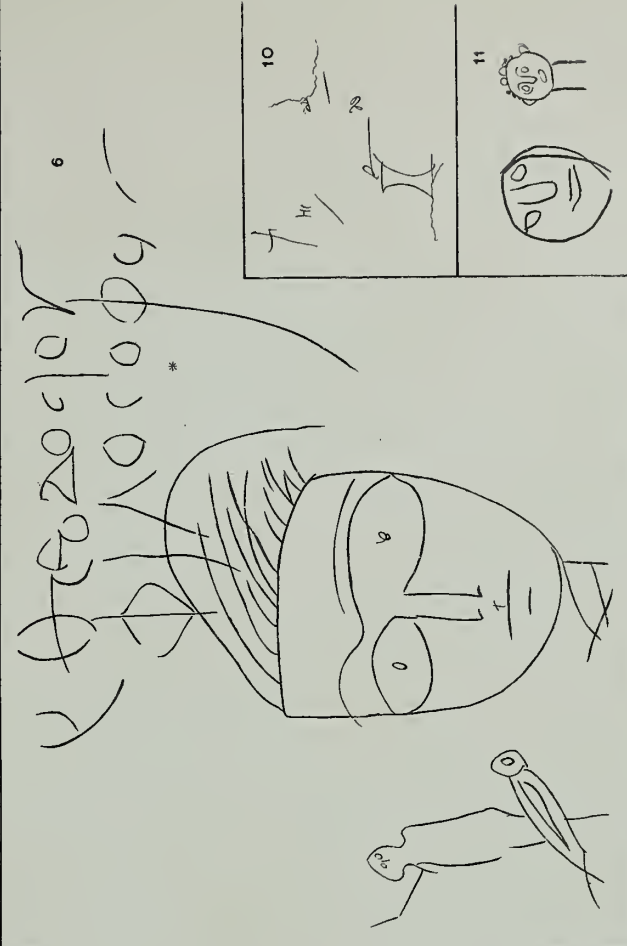
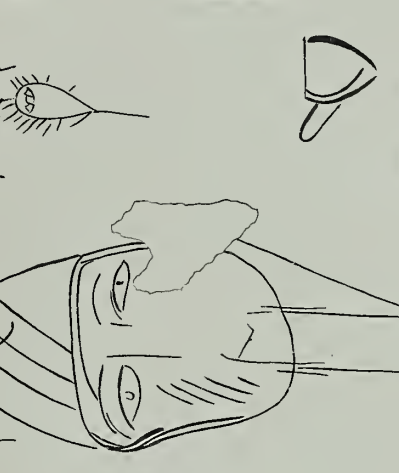
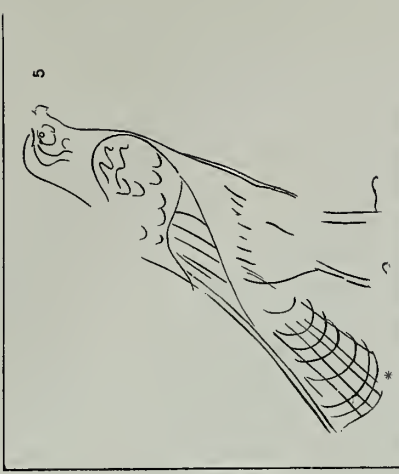

10
 11
 12
 13
 14
 15
 16
 17
 18
 19
 20
 21
 22
 23
 24
 25
 26
 27
 28
 29
 30
 31
 32
 33
 34
 35
 36
 37
 38
 39
 40
 41
 42
 43
 44
 45
 46
 47
 48
 49
 50
 51
 52
 53
 54
 55
 56
 57
 58
 59
 60
 61
 62
 63
 64
 65
 66
 67
 68
 69
 70
 71
 72
 73
 74
 75
 76
 77
 78
 79
 80
 81
 82
 83
 84
 85
 86
 87
 88
 89
 90
 91
 92
 93
 94
 95
 96
 97
 98
 99
 100

10
 11
 12
 13
 14
 15
 16
 17
 18
 19
 20
 21
 22
 23
 24
 25
 26
 27
 28
 29
 30
 31
 32
 33
 34
 35
 36
 37
 38
 39
 40
 41
 42
 43
 44
 45
 46
 47
 48
 49
 50
 51
 52
 53
 54
 55
 56
 57
 58
 59
 60
 61
 62
 63
 64
 65
 66
 67
 68
 69
 70
 71
 72
 73
 74
 75
 76
 77
 78
 79
 80
 81
 82
 83
 84
 85
 86
 87
 88
 89
 90
 91
 92
 93
 94
 95
 96
 97
 98
 99
 100

2
 3
 4
 5
 6
 7
 8
 9
 10
 11
 12
 13
 14
 15
 16
 17
 18
 19
 20
 21
 22
 23
 24
 25
 26
 27
 28
 29
 30
 31
 32
 33
 34
 35
 36
 37
 38
 39
 40
 41
 42
 43
 44
 45
 46
 47
 48
 49
 50
 51
 52
 53
 54
 55
 56
 57
 58
 59
 60
 61
 62
 63
 64
 65
 66
 67
 68
 69
 70
 71
 72
 73
 74
 75
 76
 77
 78
 79
 80
 81
 82
 83
 84
 85
 86
 87
 88
 89
 90
 91
 92
 93
 94
 95
 96
 97
 98
 99
 100

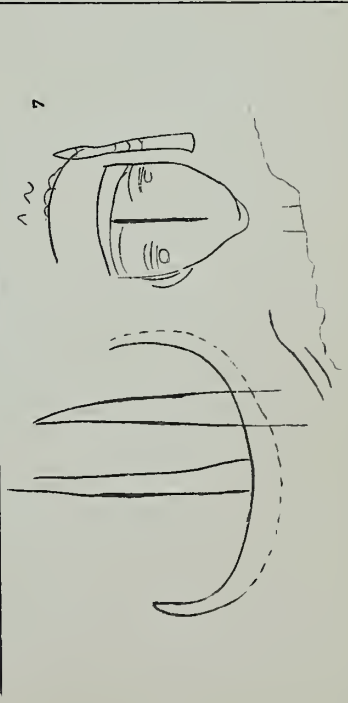
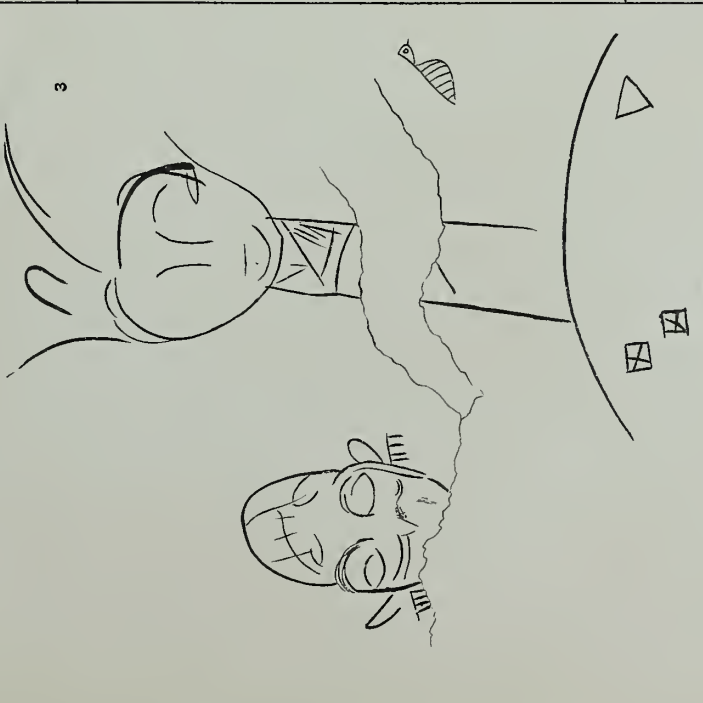





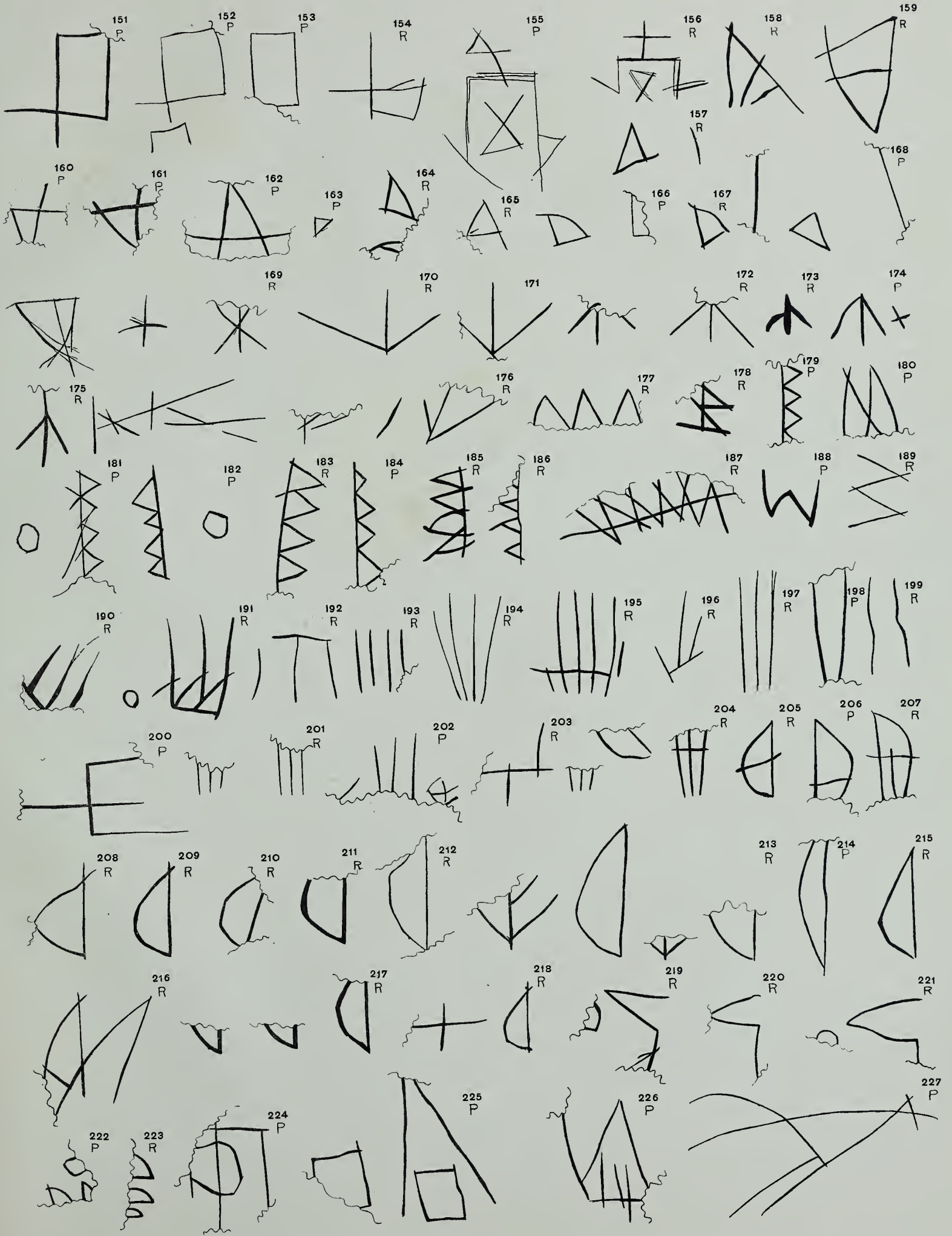

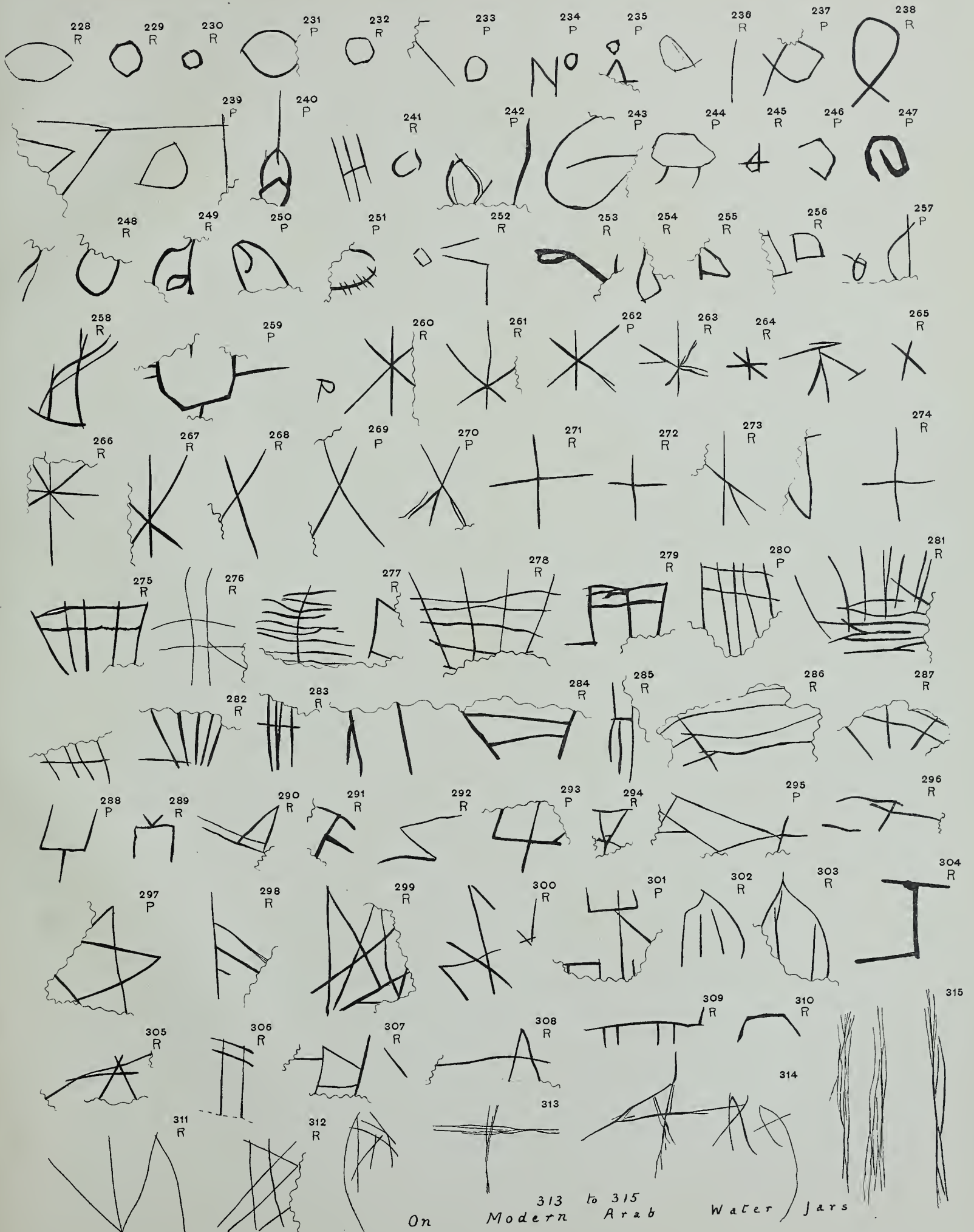

On Modern Arab Water Jars



flap

GETTY RESEARCH INSTITUTE



3 3125 01451 6047

PUBLICATIONS OF THE EGYPT EXPLORATION FUND.

- I.—THE STORE CITY OF PITHOM AND THE ROUTE OF THE EXODUS. Memoir for 1883-84. By EDOUARD NAVILLE. 13 Plates, Map and Plan. Fourth and Revised Edition. (*In Preparation.*)
- II.—TANIS. Part I. Memoir for 1884-85. By W. M. FLINDERS PETRIE. 16 Plates and 2 Plans. Second Edition. 25s.
- III.—NAUKRATIS. Part I. Memoir for 1885-86. By W. M. FLINDERS PETRIE. With Chapters by CECIL SMITH, ERNEST A. GARDNER, and BARCLAY V. HEAD. 44 Plates and 7 Plans. Second Edition. 25s.
- IV.—GOSHEN, AND THE SHRINE OF SAFT EL HENNEH. Memoir for 1886-87. By EDOUARD NAVILLE. 11 Plates and Plans. Second Edition. 25s.
- V.—TANIS. Part II., including TELL DEFENNEH (the Biblical "Tahpanhes") and TELL NEBESHEH. Memoir for 1887-88. By W. M. FLINDERS PETRIE, F. LL. GRIFFITH, and A. S. MURRAY. 51 Plates and Plans. 25s.
- VI.—NAUKRATIS. Part II. Memoir for 1888-89. By ERNEST A. GARDNER and F. LL. GRIFFITH. 24 Plates and Plans. 25s.
- VII.—THE CITY OF ONIAS AND THE MOUND OF THE JEW. The Antiquities of Tell-el-Yahûdiyeh. *Extra Volume* for 1888-89. By EDOUARD NAVILLE and F. LL. GRIFFITH. 26 Plates and Plans. 25s.
- VIII.—BUBASTIS. Memoir for 1889-90. By EDOUARD NAVILLE. 54 Plates and Plans. 25s.
- IX.—TWO HIEROGLYPHIC PAPYRI FROM TANIS. By F. LL. GRIFFITH and W. M. FLINDERS PETRIE. *An extra Volume.* Price 5s.
- X.—THE FESTIVAL HALL OF OSORKON II. (BUBASTIS). Memoir for 1890-91. By EDOUARD NAVILLE. With 39 Plates. 25s.
- XI.—AHNAS EL MEDINEH. Memoir for 1891-92. By EDOUARD NAVILLE; and THE TOMB OF PAHERI AT EL KAB. By J. J. TYLOR and F. LL. GRIFFITH. With 27 Plates. 25s. Also separately, THE TOMB OF PAHERI. By J. J. TYLOR. *Edition de Luxe*, £2 2s.
- XII.—DEIR EL BAHARI. Introductory. Memoir for 1892-93. By EDOUARD NAVILLE. 15 Plates and Plans. 25s.
- XIII.—DEIR EL BAHARI. Part I. Memoir for 1893-94. By EDOUARD NAVILLE. Plates I.-XXIV. (3 coloured), with description. Royal folio. 30s.
- XIV.—DEIR EL BAHARI. Part II. Memoir for 1894-95. By EDOUARD NAVILLE. Plates XXV.-LV. (2 coloured), with description. Royal folio. 30s.
- XV.—DESHASHEH. Memoir for 1895-96. By W. M. FLINDERS PETRIE. Photogravure and 37 other Plates. 25s.
- XVI.—DEIR EL BAHARI. Part III. Memoir for 1896-97. By EDOUARD NAVILLE. Plates LVI.-LXXXVI. (2 coloured), with description. Royal folio. 30s.
- XVII.—DENDEREH. Memoir for 1897-98. By W. M. FLINDERS PETRIE. With 38 Plates. 25s. Special Memoir, consisting of 33 Extra Plates. 10s.
- XVIII.—ROYAL TOMBS OF THE FIRST DYNASTY AT ABYDOS. Memoir for 1898-99. By W. M. FLINDERS PETRIE. With 68 Plates. 25s.
- XIX.—DEIR EL BAHARI. Part IV. Memoir for 1899-1900. (*In Preparation.*)

PUBLICATIONS OF THE ARCHAEOLOGICAL SURVEY OF EGYPT.

Edited by F. LL. GRIFFITH.

- I.—BENI HASAN. Part I. For 1890-91. By PERCY E. NEWBERRY. With Plans and Measurements of the Tombs by G. W. FRASER. 49 Plates (4 coloured). Price 25s.
- II.—BENI HASAN. Part II. For 1891-92. By PERCY E. NEWBERRY. With Appendix, Plans and Measurements by G. W. FRASER. 37 Plates (2 coloured). Price 25s.
- III.—EL BERSHEH. Part I. For 1892-93. By F. LL. GRIFFITH and PERCY E. NEWBERRY. 34 Plates (2 coloured). Price 25s.
- IV.—EL BERSHEH. Part II. For 1893-94. By F. LL. GRIFFITH and PERCY E. NEWBERRY. With Appendix by G. W. FRASER. 23 Plates (2 coloured). Price 25s.
- V.—BENI HASAN. Part III. For 1894-95. By F. LL. GRIFFITH. 10 Coloured Plates. Price 25s.
- VI.—HIEROGLYPHS FROM THE COLLECTIONS OF THE EGYPT EXPLORATION FUND. For 1895-96. By F. LL. GRIFFITH. 9 Coloured Plates. Price 25s.
- VII.—BENI HASAN. Part IV. For 1896-97. By F. LL. GRIFFITH. 27 Plates (21 coloured). 25s.
- VIII.—THE MASTABA OF PTAHHETEP AND AKHETHETEP AT SAQQAREH. Part I. For 1897-98. By N. DE G. DAVIES. 31 Photographic and other Plates (3 coloured). 25s.
- IX.—THE MASTABA OF PTAHHETEP AND AKHETHETEP AT SAQQAREH. Part II. For 1898-99. By N. DE G. DAVIES. (*In Preparation.*)

PUBLICATIONS OF THE GRAECO-ROMAN BRANCH.

- I.—THE OXYRHYNCHUS PAPYRI. Part I. For 1897-98. By BERNARD P. GRENFELL and ARTHUR S. HUNT. With 8 Plates. 25s.
- II.—THE OXYRHYNCHUS PAPYRI. Part II. For 1898-99. By BERNARD P. GRENFELL and ARTHUR S. HUNT. With 8 Plates. 25s.
- III.—FAYÛM TOWNS AND THEIR PAPYRI. For 1899-1900. By B. P. GRENFELL, A. S. HUNT, and D. G. HOGARTH. With 18 Plates. 25s.

ARCHAEOLOGICAL REPORTS.

(Yearly Summaries by F. G. KENYON, W. E. CRUM, and the Officers of the Society.) Edited by F. LL. Griffith.
From 1892-93 to 1899-1900. 2s. 6d.

ATLAS OF ANCIENT EGYPT. With Letterpress and Index. Second Edition. 3s. 6d.

GUIDE TO TEMPLE OF DEIR EL BAHARI. With Plan. 6d.

ΛΟΓΙΑ ΙΗΣΟΥ: Sayings of our Lord. By B. P. GRENFELL and A. S. HUNT. 2s. (with Collotypes), and 6d. net.

OFFICES OF THE EGYPT EXPLORATION FUND:
37, Great Russell Street, London, W.C.;
and 59, Temple Street, Boston, Mass., U.S.A.