



Calhoun: The NPS Institutional Archive
DSpace Repository

Theses and Dissertations

1. Thesis and Dissertation Collection, all items

1996-12

**Sustainment support for Naval Construction
Forces operating with Marine Air-Ground Task Forces**

Loudy, Michael E.

Monterey, California. Naval Postgraduate School

<http://hdl.handle.net/10945/32004>

Downloaded from NPS Archive: Calhoun



Calhoun is a project of the Dudley Knox Library at NPS, furthering the precepts and goals of open government and government transparency. All information contained herein has been approved for release by the NPS Public Affairs Officer.

Dudley Knox Library / Naval Postgraduate School
411 Dyer Road / 1 University Circle
Monterey, California USA 93943

<http://www.nps.edu/library>

NAVAL POSTGRADUATE SCHOOL
Monterey, California



THESIS

**SUSTAINMENT SUPPORT FOR NAVAL
CONSTRUCTION FORCES OPERATING WITH
MARINE AIR-GROUND TASK FORCES**

by

Michael E. Loudy

December, 1996

Principal Advisor:
Associate Advisor:

Paul J. Fields
Kevin R. Gue

Approved for public release; distribution is unlimited.

19970630 014

REPORT DOCUMENTATION PAGE

Form Approved OMB No. 0704-0188

Public reporting burden for this collection of information is estimated to average 1 hour per response, including the time for reviewing instruction, searching existing data sources, gathering and maintaining the data needed, and completing and reviewing the collection of information. Send comments regarding this burden estimate or any other aspect of this collection of information, including suggestions for reducing this burden, to Washington Headquarters Services, Directorate for Information Operations and Reports, 1215 Jefferson Davis Highway, Suite 1204, Arlington, VA 22202-4302, and to the Office of Management and Budget, Paperwork Reduction Project (0704-0188) Washington DC 20503.

1. AGENCY USE ONLY (Leave blank)	2. REPORT DATE December 1996	3. REPORT TYPE AND DATES COVERED Master's Thesis	
4. TITLE AND SUBTITLE SUSTAINMENT SUPPORT FOR NAVAL CONSTRUCTION FORCES OPERATING WITH MARINE AIR-GROUND TASK FORCES		5. FUNDING NUMBERS	
6. AUTHOR(S) Loudy, Michael E.			
7. PERFORMING ORGANIZATION NAME(S) AND ADDRESS(ES) Naval Postgraduate School Monterey CA 93943-5000		8. PERFORMING ORGANIZATION REPORT NUMBER	
9. SPONSORING/MONITORING AGENCY NAME(S) AND ADDRESS(ES)		10. SPONSORING/MONITORING AGENCY REPORT NUMBER	
11. SUPPLEMENTARY NOTES The views expressed in this thesis are those of the author and do not reflect the official policy or position of the Department of Defense or the U.S. Government.			
12a. DISTRIBUTION/AVAILABILITY STATEMENT Approved for public release; distribution is unlimited.		12b. DISTRIBUTION CODE	
13. ABSTRACT (maximum 200 words) This thesis examines how Naval Construction Forces (NCFs) Operating with Marine Air-Ground Task Forces (MAGTFs) receive sustainment support. Restructuring of the military forces, in particular the Marine Corps engineer units, has resulted in an increase in the mission-dependent general engineering support that the Seabees provide to MAGTFs. The Seabees have developed a robust initial sustainment capability that serves them well in independent operations, but that can be a significant liability when operating with MAGTFs. This thesis analyzes the impact this robust sustainment capability has on the Seabees when they deploy in support of MAGTFs in terms of mobility and footprint. The research shows that elimination of initial sustainment material from the Seabees can reduce the Aircraft Load (ACL) requirements for the four Navy Mobile Construction Battalions (NMCBs) notionally slated to support a Marine Expeditionary Force (MEF) by more than 46 C-141B ACLs. Additional savings can be realized by realigning the medical capability of the NMCBs to a configuration similar to a comparable Marine Corps engineer unit. This reconfiguration would save weight and space as well as allow the NCF to eliminate almost \$5 million in medical equipment from its NMCBs.			
14. SUBJECT TERMS Naval Construction Forces, Sustainment, Aircraft Loads, General Engineering Support		15. NUMBER OF PAGES 89	16. PRICE CODE
17. SECURITY CLASSIFICATION OF REPORT Unclassified	18. SECURITY CLASSIFICATION OF THIS PAGE Unclassified	19. SECURITY CLASSIFICATION OF ABSTRACT Unclassified	20. LIMITATION OF ABSTRACT UL

NSN 7540-01-280-5500

Standard Form 298 (Rev. 2-89)
Prescribed by ANSI Std. Z39-18 298-102

Approved for public release; distribution is unlimited.

**SUSTAINMENT SUPPORT FOR NAVAL CONSTRUCTION FORCES
OPERATING WITH MARINE AIR-GROUND TASK FORCES**

Michael E. Loudy
Major, United Marine Corps
B.S., University of Nebraska, 1982

Submitted in partial fulfillment
of the requirements for the degree of

MASTER OF SCIENCE IN MANAGEMENT

from the

**NAVAL POSTGRADUATE SCHOOL
December 1996**

Author:

Michael E. Loudy

Approved by:

Paul J. Fields, Principal Advisor

Kevin R. Gue, Associate Advisor

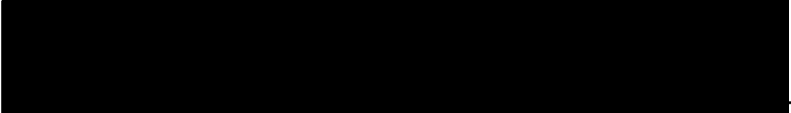
Rueben T. Harris, Chairman
Department of Systems Management

ABSTRACT

This thesis examines how Naval Construction Forces (NCFs) Operating with Marine Air-Ground Task Forces (MAGTFs) receive sustainment support. Restructuring of the military forces, in particular the Marine Corps engineer units, has resulted in an increase in the mission-dependent general engineering support that the Seabees provide to MAGTFs. The Seabees have developed a robust initial sustainment capability that serves them well in independent operations, but that can be a significant liability when operating with MAGTFs. This thesis analyzes the impact this robust sustainment capability has on the Seabees when they deploy in support of MAGTFs in terms of mobility and footprint. The research shows that elimination of initial sustainment material from the Seabees can reduce the Aircraft Load (ACL) requirements for the four Navy Mobile Construction Battalions (NMCBs) notionally slated to support a Marine Expeditionary Force (MEF) by more than 46 C-141B ACLs. Additional savings can be realized by realigning the medical capability of the NMCBs to a configuration similar to a comparable Marine Corps engineer unit. This reconfiguration would save weight and space as well as allow the NCF to eliminate almost \$5 million in medical equipment from its NMCBs.

TABLE OF CONTENTS

I.	INTRODUCTION	1
A.	BACKGROUND	1
B.	OBJECTIVE OF THE RESEARCH	3
C.	RESEARCH QUESTIONS	6
D.	SCOPE AND LIMITATIONS	8
E.	ORGANIZATION OF THE THESIS	9
II.	OVERVIEW OF NAVAL CONSTRUCTION FORCE SUPPORT OF MARINE AIR- GROUND TASK FORCE OPERATIONS	11
A.	OPERATIONAL HISTORY	11
1.	World War II -- Birth of the Seabees	11
2.	Korea -- Reorganization of the Seabees	13
3.	Vietnam Era	14
4.	Post-Vietnam	15
B.	MISSION OF THE NAVAL CONSTRUCTION FORCE (NCF)	15
C.	ORGANIZATION OF NCF UNITS ASSIGNED TO MAGTFs	17
1.	Naval Construction Regiment (NCR) Command Element (CE)	18
2.	Naval Mobile Construction Battalion (NMCB)	18
3.	Naval Mobile Construction Battalion (NMCB) Air Detachment (Air DET)	19
4.	Naval Construction Force Support Unit (NCFSU)	20
5.	Underwater Construction Team (UCT)	21

D.	DOCTRINAL GUIDANCE	22
1.	Terms of Reference (TOR)	22
2.	FMFM 13-4/NWP 22-9	23
3.	NWP 4-04.1/MCRP 4-5.4 (DRAFT)	24
III.	CURRENT SUSTAINMENT SUPPORT PRACTICES FOR NCF IN SUPPORT OF MAGTF OPERATIONS	25
A.	SEABEE SUSTAINMENT CONCEPTS	25
1.	Standardization	25
2.	Organic Sustainment in Initial Stages	27
B.	SUSTAINMENT PLANNING FOR OPERATIONS IN SUPPORT OF MAGTFS	29
C.	ANALYSIS OF CURRENT PRACTICES	30
1.	Heavy Embarkation Lift Penalty	31
2.	Footprint	36
3.	Class VIII (Medical) -- A Special Case	39
a.	<i>Unbalanced Personnel Assignments</i>	39
b.	<i>Medical/Dental Equipment</i>	41
c.	<i>Footprint</i>	42
d.	<i>Cost Savings</i>	44
4.	No Common Item Support	46
a.	<i>Doctrine & Policy</i>	46
b.	<i>Procedure</i>	47
5.	System Incompatibilities	48

IV.	ALTERNATIVE SUSTAINMENT SUPPORT PRACTICES FOR NCF IN SUPPORT OF MAGTF OPERATIONS	51
A.	STATUS QUO	51
	1. Robust Organization	51
	2. Robust Sustainment	51
	3. Independent Sustainment Chain for Class IX	52
B.	ALTERNATIVE POLICIES AND ORGANIZATIONAL CHANGES	53
	1. Receive all sustainment from the Marine Corps with the exception of Non-Common Class IX (Repair Parts)	54
	2. Realign Medical Capability	56
	3. Request Common Item Support from MAGTF	58
	4. Adopt Marine Corps' ATLASS	58
V.	CONCLUSIONS AND RECOMMENDATIONS	61
A.	CONCLUSIONS	61
B.	RECOMMENDATIONS	63
	1. MAGTFs Provide Seabees All Sustainment Except Non-Common Class IX (Repair Parts)	63
	2. Reorganization of Medical Section	64
	3. Conduct Field Testing of Marine Corps' ATLASS to Determine its Suitability for Use with Seabees Operating with MAGTFs	65
	4. Aggressively Pursue Field Exercises with MAGTFs	65

C.	RECOMMENDATIONS FOR FURTHER STUDY	66
1.	Optimum Organization of Naval Construction Forces Operating with MAGTFs	66
3.	Dedicate Selected NMCBs to Support of MAGTFs .	66
4.	Optimum Commonality of Equipment	67
	APPENDIX A. COMPARISON OF ENGINEERING CAPABILITIES	69
	APPENDIX B. CLASSES OF SUPPLY	71
	LIST OF REFERENCES	75
	INITIAL DISTRIBUTION LIST	77

I. INTRODUCTION

In reflecting on his experiences of World War II, Marine Lieutenant General Holland M. "Howling Mad" Smith had this to say about the U.S. Navy Seabees:

In my humble opinion the formation of the Seabees was one of the finest developments of this last war. The outstanding work of the Seabees and their magnificent courage in battle played a most important part in the successful prosecution of the war. It is not an unusual sight to witness the Seabees performing their duties under fire. It was an inspiring sight, for instance, to see them working on one end of the airfield while the Marines were fighting on the other end. The spirit of brotherhood existing between the Marines and the Seabees was forged in the holocaust of battle. Perhaps I can sum up this brief message in these few words, "THE SEABEES NEVER LET US DOWN." [Ref. 1]

A. BACKGROUND

The Naval Construction Force (NCF), frequently referred to as the Seabees, is a generic term applied to that group of deployable Naval organizations which provide numerous general engineering capabilities in support of the U.S. Navy and the U.S. Marine Corps. Among these capabilities are ship-to-shore construction support operations and military construction in support of MAGTF operations and amphibious assaults.

Seabees and Marines have worked side by side in our nation's conflicts since the Seabees were first formed during World War II. LtGen Holland Smith's remarks

concerning the unique relationship between the U.S. Marine Corps and the sailors of the U.S. Navy's Naval Construction Force, made following World War II, remain true today. In fact, an effective argument can be made that the operational effectiveness of Marine Air-Ground Task Forces (MAGTF) is even more dependant on the engineering functions performed by the Navy's Seabees now, than it was in LtGen Holland Smith's era.

Several recent events have lead to a further strengthening of these historically strong ties between the Seabees and the U.S. Marine Corps. Recent contingencies have seen Seabees operating with MAGTFs in major operations in Southwest Asia and Somalia, and in numerous other smaller operations throughout the world. The recent downsizing of U.S. military forces, including the Marine Corps and the Navy, have resulted in a significant reduction of the Marine Corps' organic engineering capabilities. Doctrinal relationships that are now being refined (NWP 04.01/MCRP 4-5.4 DRAFT) provide for the Seabees to contribute critical engineering capabilities that the Marine Corps' organic engineer units cannot provide. In particular, the Marine Corps ability to provide engineering support for expeditionary airfields and bridging requirements has been

virtually eliminated. These missions now fall directly on the shoulders of the Seabees. [Ref. 2]

Additionally, continuing fiscal constraints and the emphasis on joint operations provide pressures for both the Marine Corps and the Navy to continue to explore and refine ways in which they can work together in the most effective and economical manner.

B. OBJECTIVE OF THE RESEARCH

Operational relationships between the Seabees and the Marine Corps continue to evolve and change. Among the primary areas of concern that must be resolved are the levels of each class of supply the Seabees will deploy with, and the manner in which sustainment for each of these classes of supply will be accomplished while operating with MAGTFs. Three areas in particular require careful consideration for potential refinement of doctrinal policy: organic medical capabilities, the level of embarked sustainment material and follow-on repair parts sustainment procedures.

The organic medical capability of a Seabee battalion far exceeds that of a comparable Marine Corps engineer support battalion. Because Seabees have frequently deployed independently on missions requiring them to be essentially self supporting, their medical capability has evolved to

include ancillary medical equipment such as x-ray machines and surgical laboratories that duplicate services provided by the MAGTF's own medical units. These services are unnecessary within the structure of a general support battalion, and more importantly, they reduce the mobility of the Seabee units, create a larger footprint in their area of operations, and create a significant increase in their maintenance management burden. [Ref. 3]

Additionally, the number of days of supply the Seabees deploy with is different than the days of supply the MAGTF deploys with. The greatest difference occurs among repair parts. Seabees currently deploy with a 60-day stock of repair parts, and submit requisitions for required replacements directly from themselves through their established U.S. Navy supply chain. Marine Corps doctrine calls for a MAGTF to deploy with 30 days of supply of repair parts, and utilize a MAGTF established supply chain. The Seabee process bypasses the deployed MAGTF supply chain.

These policies have several deleterious effects. For example, they effectively deny the Seabees the opportunity to benefit from the potential common item support the MAGTF could provide¹. They also require the Seabees to deploy

1

Common item support refers to like items that are shared by both the Seabees and the Marine Corps.

with a greater footprint and cause a corresponding reduction in the Seabee units mobility. In addition they do not allow the Seabees to benefit from MAGTF prioritization of their requisitions and they create the additional burden of establishing a separate supply sustainment chain for Seabee required items.

Eliminating these areas of common item overlap and utilizing the established MAGTF supply chain could result in several potential benefits: reduction of the mount-out logistics burden on the deploying Seabee unit; increased responsiveness in support of common item requisitions; decrease in the Seabee units footprint; reduction in the maintenance burden of excess equipment and parts; increase in the Seabee units mobility in the area of operations; reduction in the financial burden of stock management; management efficiencies gained through utilization of a single, common logistics chain into the area of operations for the Seabees and MAGTF; and Seabee requisitions being prioritized in accordance with MAGTF priorities vice competing with fleet priorities.

The objective of this research is to evaluate the levels of stock in all classes of supplies that the Seabees deploy with, and to additionally examine the present processes for providing supply sustainment to Seabees

deployed with MAGTFs. The emphasis is on examining areas where unnecessary redundancy occurs. Additionally, the research examines the Seabees methods of supply sustainment to identify potential improvements in effectiveness and efficiency.

This thesis initially examines the level of sustainment the Seabees plan to deploy with across each class of supply, and then examines how the Seabees plan to obtain sustainment support in all classes of supply. The thesis then looks at alternative processes and procedures that provide the potential to enhance the supply support received by the Seabees when they are deployed with MAGTFs.

C. RESEARCH QUESTIONS

The primary research question that is addressed in this thesis is: How can sustainment support for the Seabees serving with MAGTFs be provided in the most responsive manner while enhancing the mobility of the Seabees and minimizing the logistics footprint ashore?

Subsidiary research questions addressed in each chapter are as follows:

1. Chapter I
 - a. What is the critical role that the Seabees fulfill in USMC requirements for heavy engineering support?

- b. What does the future hold for this relationship considering downsizing of the military forces, increased emphasis on joint operations, and increased tempo of operations?
- c. What areas of supply sustainment for Seabees in support of MAGTFs can be improved to enhance the MAGTFs accomplishment of its mission?

2. Chapter II

- a. What are the historical relationships for Seabee support of MAGTF operations?
- b. How are the Seabees organized in support of MAGTFs?
- c. What doctrinal guidelines direct the operational relationship between the Seabees and supported MAGTFs?

3. Chapter III

- a. What guides the Seabees in the days of supply they deploy with for MAGTF operations?
- b. What level of days of supplies do equivalent Marine Corps battalions deploy with for MAGTF operations?
- c. How do the Seabees intend to receive sustainment for each class of supply while deployed with MAGTFs?
- d. What lessons can be learned from recent operations concerning Seabee requirements for sustainment support while deployed with MAGTFs?
- e. Are changes in sustainment support for Seabees deployed with MAGTFs advantageous?

4. Chapter IV

- a. What alternative procedures exist that could improve sustainment support for Seabees deployed with MAGTFs?
- b. What alternative processes exist that could improve sustainment support for Seabees deployed with MAGTFs?
- c. What changes in doctrine could be made to improve sustainment support for Seabees deployed with MAGTFs?
- d. How easily can recommended changes in procedures, processes and doctrine be adopted?

D. SCOPE AND LIMITATIONS

This thesis concentrates on improving the sustainment support for Seabees deployed with MAGTFs. In addition to research of doctrinal publications and other reference material, the thesis is based on interviews with members of the following organizations: Third Naval Construction Brigade at Pearl Harbor, Hawaii and Port Hueneme, California; Second Naval Construction Brigade at Little Creek, Virginia; and First Marine Expeditionary Force at Camp Pendleton, California. While it primarily examines the relationship between the Third Naval Construction Brigade and the First Marine Expeditionary Force, the expected benefits of the recommendations contained herein should apply to the relationship between other Marine Expeditionary Forces and their supporting Seabees.

E. ORGANIZATION OF THE THESIS

This chapter provides an introduction to the thesis and the problem of sustainment support that is explored in the following chapters. Chapter II looks at the history of Seabee support of Marine Forces, with special emphasis on the development of doctrine and policy. Chapter III examines by class of supply how the Seabees deploy, and are then sustained when serving with MAGTFs. Chapter IV discusses alternative procedures, processes and doctrine that can be adopted to enhance sustainment support for the Seabees. Chapter V provides conclusions, recommendations and suggested areas for further study.

II. OVERVIEW OF NAVAL CONSTRUCTION FORCE SUPPORT OF MARINE AIR-GROUND TASK FORCE OPERATIONS

A. OPERATIONAL HISTORY

1. World War II -- Birth of the Seabees

The U.S. Navy created its Civil Engineer Corps (CEC) in 1842, as a part of its Bureau of Yards and Docks. In the 100 years that followed, the Navy depended on these CEC officers and civilian contractors for construction support. After the Japanese attack on Pearl Harbor, the use of civilian labor in war zones became impractical. International law prohibited civilians from lawfully resisting enemy military attack and resistance on the part of the civilians could result in their summary execution as guerrillas. [Ref. 4]

At the outset of WWII, the U.S. Navy had more than 70,000 civilians under contract outside of the continental United States. On 23 December 1941, a 1,200 man construction crew on Wake Island was captured. More than 50 civilians were killed, with the survivors shipped to China to spend the remainder of the war as military prisoners. As a consequence of this event, morale of the civilian contractors was very poor. In response, VAdm Ben Moreell, Chief of Civil Engineers of the Navy, requested authority to enlist men into the Navy for construction duty.

On 5 January 1942, the Bureau of Navigation authorized him to recruit men from the construction trades for assignment to a Naval Construction Regiment composed of three Naval Construction Battalions [Ref. 4]. "In less than a month (February 1942) the first unit was deployed to Bora Bora, Tahiti, to build a fuel tank farm." [Ref. 5] The Seabees recognize 5 March 1942 as their birth date, the date they adopted "Seabees" as their official name. "Seabees" was derived from a transliteration of the initial letters of Construction Battalion, or "CB."

More than 10,000 CEC officers and 240,000 enlisted personnel served with the Seabees in its Pacific campaigns. Most of them served in naval construction battalions that were components of the five Marine engineer regiments deployed to the Pacific from 1942 to 1944. [Ref 1]

Throughout the war, the Seabees built hundreds of airfields from the jungle for Navy and Marine aviators, set up galleys to feed Marines ashore, built base camps and created harbors and ports where none should have existed.... Seabee support of Marine combat elements was replicated throughout the Pacific campaign. Seabees created the infrastructure that enabled the Navy/Marine Team to island hop all the way to Okinawa. [Ref. 5]

The years following WWII found the Seabees continuing their construction efforts as they helped repair and rebuild the war-torn Pacific island countries.

2. Korea -- Reorganization of the Seabees

Korea found the Seabees once again performing vital wartime support. At the Inchon landing in September of 1950 they assisted the amphibious assault by positioning critical pontoon causeways while under continuous enemy fire. Seabees also served in numerous detachments formed to provide engineering support for the many expeditionary airfields of the Marine Air Groups (MAGs).

Korea also saw completion of a basic reorganization of the Seabees. Two distinct types of battalions were established to provide for specialization and mobility. Amphibious Construction Battalions (PHIBCBs) were formed to place causeways, construct pontoon docks and perform other functions necessary for landing personnel and equipment in the shortest possible time. The Naval Mobile Construction Battalions (NMCBs) were formed to provide for land construction of a wide variety which includes military camps, roads, bridges, tank farms, airstrips, and docking facilities. [Ref. 4] The Seabees of today are organized in this manner.

In the years following Korea, the Seabees concentrated more on building than they did fighting. Seabees were involved in construction projects around the globe, including missile ranges in both the Atlantic and Pacific

and military housing complexes all over the world. In response to the Cuban Missile Crisis in 1962 Seabees hastily constructed and helped man a formidable defensive perimeter at Guantanamo Bay, Cuba.

3. Vietnam Era

Vietnam found the Seabees and Marines once again thrust into battle together. The Seabees not only provided combat engineering support, such as reconstructing two vitally-needed concrete bridges during the Tet Offensive [Ref. 1] but they were heavily involved in civic action projects as well. These civic action projects paved roads between farms and markets, drilled fresh water wells, and constructed numerous schools, hospitals, utility systems, and other community facilities.

Other fundamental activities also took root. Seabees were often integrated with Marines into perimeter security. Perhaps of even more importance to the individual Marine, the Seabees had what was generally recognized as the best refrigeration units in Vietnam, and those units often became the best morale, welfare and recreation available to those assigned to the remote northern areas of South Vietnam.

[Ref. 5]

4. Post-Vietnam

The years following Vietnam found the Seabees once again returning to peacetime building projects, including Diego Garcia in the Indian Ocean and Guam. More significantly, in recent years the Seabees have found themselves once again operating closely with their Marine counterparts. More than 5,000 Seabees served in Southwest Asia during Operations Desert Shield and Desert Storm. In Saudi Arabia they built 10 camps housing more than 42,000 personnel, 14 galleys capable of feeding 75,000 people, and 6 million square feet of aircraft parking apron. [Ref. 5]

During Operation Restore Hope in Somalia, Seabees from two NMCBs provided support ranging from construction and improvement of base camps, Main Supply Routes (MSRs), and airfields for American and combined forces, as well as their usual civic action projects. It was the author's observation of the Seabees in Somalia that provided the inspiration for this thesis.

B. MISSION OF THE NAVAL CONSTRUCTION FORCE (NCF)

The NCF is a responsive, mobile, modern, versatile engineer force, capable of accomplishing diverse tasks. These tasks range from timber bunker construction in a forward ground combat environment to construction and

operation of an advanced industrial facility in support of naval operating forces and the logistics pipeline. [Ref. 6]

The Naval Construction Force (Seabees) provide the following capabilities to the U.S. Navy, the U.S. Marine Corps, and when directed, other agencies of the U.S. government:

1. Responsive military advance base construction support including construction, maintenance, and operation of operational, logistics, underwater, ship-to-shore, shore, and deep ocean facilities.
2. Military construction in support of MAGTF operations.
3. Defensive and limited offensive operations against overt or clandestine enemy attacks directed toward unit personnel, convoys, camps, and facilities under construction.
4. Amphibious assault and ship-to-shore construction support operations.
5. Battle damage repair operations.
6. Disaster control and recovery operations.
7. Civic action employment.

As a result of recent revisions of doctrine, the Seabees are now responsible for two critical combat engineering-related missions for the MAGTFs: development of aviation support facilities, especially expansion of Expeditionary Airfields (EAFs) through construction of aircraft aprons; and relocation of tactical, fixed-panel bridging assets to forward areas of the battle field for

redeployment by Marine forces after the construction of permanent (non-standard) bridges [Ref 2]. Appendix A provides all of the engineering tasks, capabilities, and sources of support for engineer units assigned to a MEF sized MAGTF. The successful accomplishment of future MAGTF missions will be directly dependant on the successful accomplishment of these subsidiary missions.

C. ORGANIZATION OF NCF UNITS ASSIGNED TO MAGTFs

NCF units are tasked, organized, and employed to support MAGTF operations as required. Figure 2-1 illustrates an NCR structured to support a MEF.

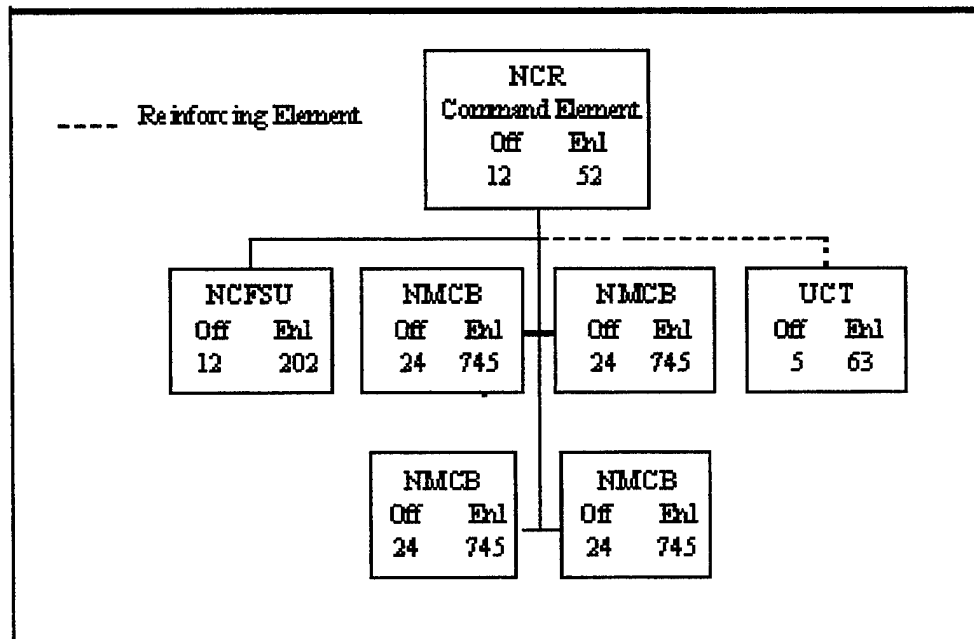

Figure 2-1, Notional Naval Construction Regiment
From NWP 4-04.1/MCRP 4-5.4

A full Marine Expeditionary Force (MEF) will normally be supported by a Naval Construction Regiment (NCR) consisting of at least two Naval Mobile Construction Battalions (NMCBs) and a Naval Construction Force Support Unit (NCFSU). [Ref. 1]

1. Naval Construction Regiment (NCR) Command Element (CE)

The NCR CE is the command and control organization for the NCR. The NCR CE is normally commanded by a Navy Civil Engineer Corps (CEC) Captain. The CE is organized into the following departments: Executive, Administrative, Intelligence, Operations, Supply, and Training. [Ref. 1]

2. Naval Mobile Construction Battalion (NMCB)

The NMCB consists of a headquarters company, equipment company, shops and utilities company, and two general construction companies. An NMCB is normally commanded by a Navy CEC Commander, and usually functions as an integral unit. NMCBs can function as integral units of the NCR, or independently as a separate unit. Eighty-five percent of an NMCB is capable of deploying as an Air Echelon via strategic airlift requiring approximately 87 C-141 or 30 C-5 equivalent lifts. The remaining fifteen percent must follow via sealift in the Sea Echelon. Figure 2-2 shows the general organization of an NMCB. [Ref. 1]

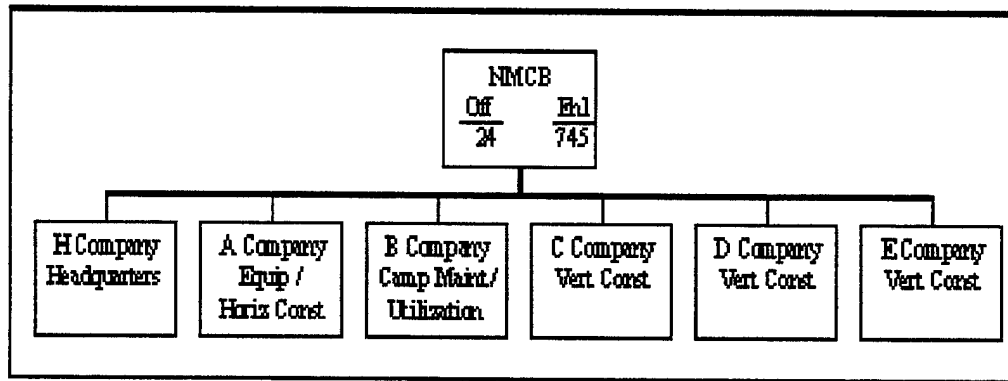

Figure 2-2. Organization of a Naval Mobile Construction Battalion From NWP 4-04.1/MCRRP 4-5.4
DRAFT

3. Naval Mobile Construction Battalion (NMCB) Air Detachment (Air DET)

An Air DET is a task-organized advance element of the NMCB whose capabilities include all of the general engineering capabilities of the NMCB. An Air DET typically consists of a headquarters section, a support section, a horizontal construction section, and a vertical construction section. The typical organization of an Air DET is shown in Figure 2-3. Normally commanded by a U.S. Navy CEC Lieutenant, it is usually composed of 89 personnel and 38 pieces of civil engineer support equipment. It is limited to 250 to 300 short tons consisting of approximately 14 C-141 or five C-5 lift equivalents. [Ref. 1]

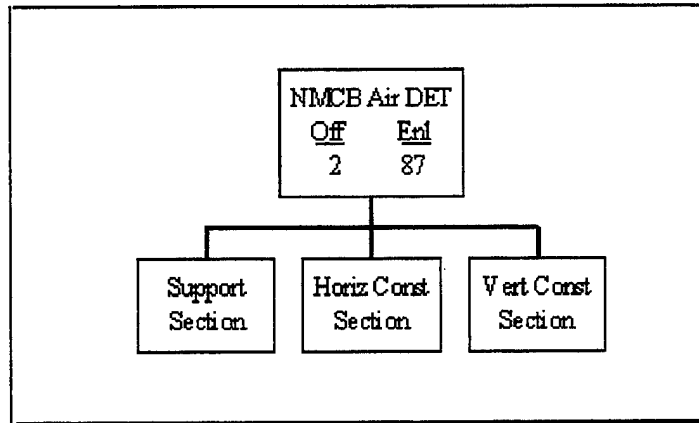

Figure 2-3. Organization of the NMCB Air Detachment From NWP 4-04.1/MCRP 4-5.4

4. Naval Construction Force Support Unit (NCFSU)

An NCFSU is normally commanded by a U.S. Navy CEC Commander. The mission of an NCFSU is to provide augmenting, logistics-oriented construction support for an NCR and up to four NMCBs. The NCFSU is organized into four sections: administrative services, equipment management, engineering support, and logistics. Figure 2-4 illustrates the organizational structure of an NCFSU. [Ref. 1]

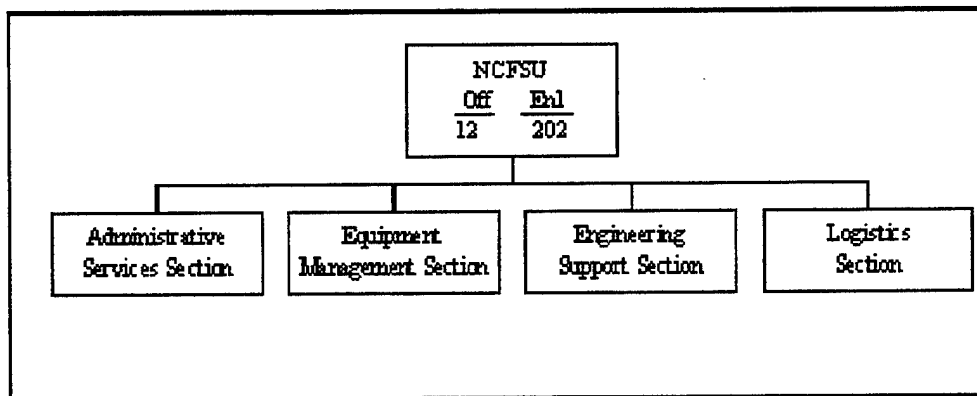

Figure 2-4. Organization of a Naval Construction Force Support Unit From NWP 4-04.1/MCRP 4-5.4

5. Underwater Construction Team (UCT)

UCTs are not routinely assigned to MAGTFs. The mission of the UCT is to provide additional engineering capabilities for the construction, inspection, and repair of ocean facilities. A UCT is normally commanded by a Navy CEC Lieutenant Commander and is designed to be self-sufficient in numerous underwater construction tasks. Figure 2-5 depicts the organization of a UCT. MAGTF commanders requiring UCT capabilities in specific operations must request them from the cognizant Naval Beach Group (NBG) through the appropriate fleet Commander in Chief (CINC). [Ref. 1]

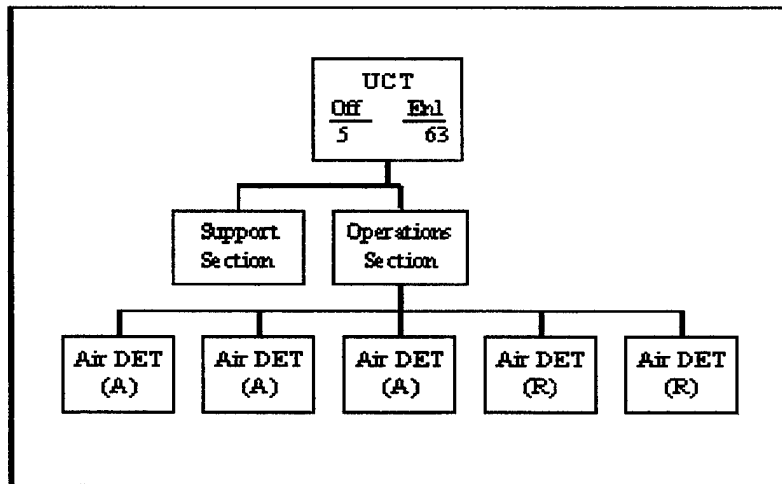

Figure 2-5. Organization of an Underwater Construction Team
From NWP 4-04.1/MCRP 4-5.4

D. DOCTRINAL GUIDANCE

1. Terms of Reference (TOR)

While the historical relationship of Seabees supporting Marine MAGTFs is well established, formal doctrinal guidance has been much slower to evolve. It was not until 1987 that senior representatives of the Navy and Marine Corps officially began to develop a doctrinal basis for Seabee support of MAGTF operations. This initial agreement, signed by LtGen J. J. Went, U.S. Marine Corps Deputy Chief of Staff for Installations and Logistics and VADM T. J. Hughes, Deputy Chief of Naval Operations (Logistics) is called the *Terms of Reference* (TOR). The TOR provided general areas of understanding concerning NCF support during MAGTF operations and outlined specific tasks and responsibilities.

The objective of the TOR was to achieve a coordinated program to ensure full and effective utilization of NCF capabilities when supporting MAGTFs. [Ref. 6]

The TOR established that Seabee units supporting MAGTFs would be under the Operational Control (OPCON)² of the MAGTF commander. Also, for the first time, the TOR provided

2

Operational control is the authority to perform those functions of command over subordinate forces involving organizing and employing commands and forces, assigning tasks, designating objectives, and giving authoritative direction necessary to accomplish the mission. It does not, in and of itself, include authoritative direction for logistics or matters of administration, discipline, internal organization, and unit training. (Joint Pub 1-02)

policy concerning responsibility for sustainment for each class of supply for Seabee units operating with MAGTFs. After depletion of NCF deployed supply stocks, the MAGTF was made responsible to provide resupply for Class I (subsistence), Class III (petroleum, oils and lubricants), Class IV (construction and barrier materials), Class V (ammunition), Class VI (personal demand items) and Class VIII (medical material). The agreements within the TOR were proven successful during Operations Desert Shield and Desert Storm when four NMCBs, the major portions of a fifth NMCB, a NCR CE, a UCT Air DET and a detail from a NCFSU were assigned to support the First Marine Expeditionary Force (I MEF). [Ref. 1]

2. FMFM 13-4/NWP 22-9

However, there was concern during Operation Desert Storm and Desert Shield that operational commanders for both the NCF and the Marine Corps were insufficiently aware of the operational relationships between the NCF and the MAGTF that the TOR provided. FMFM 13-4/NWP 22-9 was published on 9 August 1991 to provide clarification of the operational doctrine between NCFs and MAGTFs. The manual was a joint effort by doctrinal sponsors from the U.S. Marine Corps and the U.S. Navy and is the current doctrinal basis for the integration, coordination, and employment of various

components of the NCF under the operational control of a MAGTF.

3. NWP 4-04.1/MCRP 4-5.4 (DRAFT)

FMFM 13-4/NWP 29-9 and the TOR were both used to provide a doctrinal basis for Seabees in support of a MAGTF during Operation Restore Hope in Somalia. NWP 4-04.1/MCRP 4-5.4 is a publication that is now in the final draft stages and is intended to further improve the NCF and MAGTF commanders' understanding of the NCF's mission when supporting MAGTF operations. The primary areas of emphasis in the new publication are doctrinal procedures and structures that have been adopted to enhance the interoperability between the U.S. Marine Corps and the NCF. Additionally, this publication will provide planners and commanders for both the Marine Corps and the Navy extensive information on the tasks, roles, and capabilities of all of the engineering components of the MAGTF. [Ref. 1]

III. CURRENT SUSTAINMENT SUPPORT PRACTICES FOR NCF IN SUPPORT OF MAGTF OPERATIONS

A. SEABEE SUSTAINMENT CONCEPTS

Seabee planning concepts for deployment originated from their earliest experiences in World War II when it was recognized that significant savings could be made in both time and resources if units of personnel, equipment and material were standardized. Because NMCBs were frequently required to deploy to remote locations without any readily available source of sustainment, a substantial initial organic sustainment capacity was built into standard unit deployment planning as well. While the standardization of unit deployment configurations and a robust initial organic sustainment capacity have significant advantages for deployments to remote locations, they can be significant liabilities when deploying to areas where sustainment chains are already established.

1. Standardization

The Seabees quest for standardization of personnel, equipment and material led them to develop a modular system now called the Advanced Base Functional Component (ABFC) System. The ABFC system is a preplanned listing of required quantities of personnel, facilities, material and equipment required to perform specific emergency support missions or

functions. Functional components are designated by unclassified letter and number combinations. For example, P-29 is the functional component designation for an NCR and P-25 is the functional component designation for an NMCB. Each functional component and its associated facilities and assemblies are detailed to the national stock number (NSN) level. This method allows the Seabees to expediently and precisely communicate the specific requirements of an ABFC for a specific mission. [Ref. 7]

Each NCF unit within the module is supported by a Table of Allowance (TOA) that provides the equipment and material the unit requires to perform one of the specific tasks of an advanced base. The actual construction of an advanced base is one of these tasks, and the TOA for each of the NMCBs is designed for that purpose. Missions beyond the scope of the equipment and material provided by the NMCB's TOA require augmentation by some other specifically developed TOA. For major operational contingencies with MAGTFs, the Seabees plan to deploy with TOAs designed to support the construction of an advanced base. If missions require materials and equipment not in the ABFC TOAs, the Seabees require augmentation from other specially developed TOAs. Table 3-1 shows the NCF modular concept as it applies to a notional NCF supporting a MEF. [Ref. 7]

NCF Unit	Officers	Enlisted	Civil Engineering Support Equipment (CESE)
P-29 (NCR)	11	44	20
P-31 (NCFSU)	12	202	433
P-25 (NMCB)	24	738	263
P-25 (NMCB)	24	738	263
P-25 (NMCB)	24	738	263
P-25 (NMCB)	24	738	263
Total-One NCF Module	119	3198	1505

Table 3-1. NCF Module in Support of MEF

2. Organic Sustainment in Initial Stages

Original Seabee planning considerations recognized that they were not likely to be able to benefit from established sources of sustainment in the remote areas where they were expected to be constructing advance bases. In response, the Seabees built an initial organic sustainment allowance into their TOAs. [Ref. 7]

This planning has led to exceptionally robust TOAs that support virtually any contingency situation the Seabees might find themselves involved in. The downside is that this robustness exacts a heavy price by increasing both the unit's embarkation lift requirement and its footprint. These factors correspondingly degrade the battalion's

mobility during deployment and again upon arrival in the area of operations. [Ref. 8]

Additionally, many of the sustainment items require exceptional management because of their special characteristics. Items included in the TOAs that have special characteristics include explosives and other hazardous material (batteries and petroleum products) and shelf life items such as medicine and food. Since these items cannot be easily prepackaged and staged for contingencies, they cause additional extraordinary effort by the units as they prepare to deploy for contingency situations. [Ref. 8]

The end result is that when units need to concentrate on preparation of operations orders, personnel and major end items (civil engineering support equipment), they are also heavily involved in locating, collecting and preparing for embark numerous sustainment related commodities that require exceptional handling. While these sustainment related items are critical in a resource-austere environment, they become a burden to Seabee units operating with MAGTFs because the MAGTF will already have a reliable sustainment chain established prior to the Seabee's arrival. [Ref. 8]

**B. SUSTAINMENT PLANNING FOR OPERATIONS IN SUPPORT OF
MAGTFs**

Sustainment planning for Seabees in support of MAGTFs originated with the TOR in 1987. The TOR established levels of days of supply (DOS) that the Seabees would deploy with, and also the responsibility for sustainment of Seabee units operating with MAGTFs.

Under current planning guidance, the Seabees receive sustainment from three sources when under OPCON of MAGTFs: from the embarked materials they deploy with; from the Marine Corps for Class I, Class III, Class IV, Class V (W), Class VI and Class VIII items after depletion of their deployed stocks; and from the Navy for Class IX items after depletion of deployed stock [Ref. 6]. Appendix B, derived from FMFM 4-1 [Ref. 9] provides a description for all of the classes of supply. Table 3-2 indicates the level of sustainment for each class of supply the Seabees deploy with, the expected days of supply they deploy with, and the agency responsible for providing sustainment after the Seabees deplete their deployed stocks. These classes of supply include Class VII items, which the Marine Corps refers to as "major end items" for which the nearest Seabee equivalent is "Civil Engineering Support Equipment" (CESE).

Supplies	Embarked Days of Supply		Responsible Sustainment Agency
	Air Detachment	Air Echelon	
Class I (Subsistence)	5	5	Marine Corps
Class II (Individual Equipment)	0	60	Not Addressed
Class III (Petroleum, Oils and Lubricants)	5	3	Marine Corps
Class IV (Construction Material)	Advanced Base Construction Only	Advanced Based Construction Only	Marine Corps
Class V (W) (Ammunition)	5	15	Marine Corps
Class VI (Personal Demand Items)	Not Addressed	Not Addressed	Marine Corps
Class VII (Major End Items)	36 Pieces of CESE	114 Pieces of CESE	Navy
Class VIII (Medical)	Not Addressed	Not Addressed	Marine Corps
Class IX (Repair Parts)	30	60	Navy
Class X (Material to Support nonmilitary programs)	Not Applicable	Not Applicable	Requesting Agency

Table 3-2. Sustainment Support by Class of Supply

C. ANALYSIS OF CURRENT PRACTICES

While current sustainment planning considerations ensure that the Seabee units are exceptionally well prepared for any contingency they might find themselves independently operating in, there are two significant areas that provide potential for improvement: Decreased footprint and increased

mobility through reduction or elimination of the embarkation of sustainment related items, and utilization of the MAGTF supply system for common item sourcing of Class IX items (repair parts).

1. Heavy Embarkation Lift Penalty

Seabee units incur a significant penalty when deploying with their prescribed sustainment load. Table 3-3 below shows the present planned total lift requirements for an NMCB.

Echelon	Personnel	container/ sixcon	CESE	Weight (short tons)	Cubic meters	Cost
Air DET P25A	89	11/9	36	471	1,197	\$2,789,426
Air Echelon P25C	650	86/36	114	2,258	7,388	\$16,327,427
Sea Echelon P25D	24	7/0	99	1,647	4,066	\$7,949,725
TOTAL	763	107/45	249	3,051	12,689	\$26,966,578

**Table 3-3. NMCB TOA After Seabee Logistics
Agency Training Guide Series Module #2**

Table 3-4 illustrates the amount of this lift requirement that is dedicated for each class of supply. With the exception of Class VII, (Major End Items/CESE) and some components of Class VIII (Medical), this depicts the amount of lift dedicated solely to sustainment.

As Table 3-4 shows, the total sustainment load for one NMCB is almost 620,000 pounds, excluding ammunition which was not included because of its classified status, and repair parts which were not included because of the inability to discern weight attributable to items available from common item support. Most significantly, more than 530,000 pounds of the sustainment items are designated to be airlifted into the area of operations with either the Air DET or the Air Echelon.

Table 3-5 illustrates that the additional burden these sustainment items place on the Seabee's strategic airlift requirements is considerable. Considering that a minimum of four [Ref. 1] NMCBs are designated to support a MEF, the logistical burden placed upon an NCR in support of a MEF to embark its initial sustainment capability is significant.

Embarkation lift requirement is critical. The heavier an organization is, the less mobile it is. Weight will magnify the difficulty a unit experiences in being transported to an area of operations, and severely diminishes its tactical ability to maneuver and operate once it arrives in its area of operations. [Ref. 10]

Class of Supply	Air DET (P25A)		Air Echelon (P25C)		Sea Echelon (P25D)	
	Sust. Lift Reqmt.	% of Tot. Lift Reqmt.	Sust. Lift Reqmt.	% of Tot. Lift Reqmt.	Sust. Lift Reqmt.	% of Tot. Lift Reqmt.
I	3,239 lbs.	.3	52,513 lbs.	1.2	Not Planned	Not Planned
II	556 lbs.	.06	102,239 lbs.	2.3	16,842 lbs.	.5
III	46,514 lbs.	4.9	237,401 lbs.	5.3	Not Planned	Not Planned
IV	24,908 lbs.	2.6	53,380 lbs.	1.2	67,904 lbs.	2.1
V ³	Class.	Class.	Class.	Class.	Class.	Class.
VI	Not Planned	Not Planned	Not Planned	Not Planned	Not Planned	Not Planned
VII	Does Not Apply	Does Not Apply	Does Not Apply	Does Not Apply	Does Not Apply	Does Not Apply
VIII ⁴	1,698 lbs.	.2	10,991 lbs.	.2	Not Planned	Not Planned
IX	Not Included	Not Included	Not Included	Not Included	Not Included	Not Included
X	Does Not Apply	Does Not Apply	Does Not Apply	Does Not Apply	Does Not Apply	Does Not Apply
TOTAL	76,915 lbs.	8.2%	456,524 lbs.	10.1%	84,746 lbs.	2.6%

Table 3-4. Sustainment Lift Requirements by Class of Supply

In reality, the extreme airlift requirements for a Seabee battalion will probably result in only their Air Detachment (Air DET) being airlifted into the area of operation. Both the Air Echelon and Sea Echelon will most

3

Ammunition data is classified information.

4

Most, but not all, of the Class VIII materials can be removed without affecting the mission. See section III.3.3 for discussion.

likely be relegated to sea transport. This factor alone provides incentive to find ways to reduce the weight of the Seabee lift requirements. [Ref. 8]

Aircraft Type	C-130	C-141B	C-5B
Peacetime Aircraft Load (ACL)	25,000 lbs.	46,000 lbs.	130,000 lbs
ACLs required for one NMCBs sustainment material	21.3	11.6	4.9
ACLs required for four NMCBs sustainment material	85.2	46.4	16.4

Table 3-5 ACLs Required for NMCBs Sustainment Material

In the Seabees case, they not only have to arrange for embarkation of numerous classes of sustainment items that require special handling, but they have to handle the items numerous times as they prepare to deploy, when they arrive in their area of operations, and potentially several additional times as they establish their base camp. While many of their major end items (CESE) are generally self-transportable, all items of sustainment require multiple movements and handling (in the case of many of the sustainment items, special handling) before they are ultimately consumed. [Ref. 8]

The impact of the lift penalty imposed by embarking sustainment material is graphically evident when aircraft lift requirements are compared to the peacetime aircraft lift planning factors for each of the major strategic lift aircraft.

Table 3-5 illustrates how the lift capabilities of each of the major strategic lift aircraft pales in comparison to the substantial lift requirements for one NMCBs sustainment material. While the peacetime aircraft load (ACL) for preliminary load planning may be increased in wartime, there are many contingencies the Seabees might deploy to before required wartime waivers are granted.

Considering that C-5Bs are a very limited asset, it is unlikely that any would be made available to support Seabee lift requirements. The expected airlift mix would be a combination of C-130 and C-141B aircraft. Accordingly, the number of individual aircraft required just to support initial NMCB sustainment probably lies somewhere between the 45 aircraft that would be required if all lifts are made by C-141Bs, and the 82 aircraft required if all lifts are made by C-130s.

At a time when strategic lift will be at a premium, its use to support any individual units sustainment is questionable. Depending on already established sustainment chains provided by a MAGTF that is already receiving sustainment from a combination of host nation support, Maritime Prepositioned Squadrons (MPS), Military Sealift Command (MSC) vessels and airlift seems much more

appropriate than utilizing limited strategic airlift to support the Seabees initial sustainment.

Requiring Seabees to bring sustainment material with them when involved in MAGTF operations greatly degrades their preparations, embarkation and employment upon arrival, without any enhancement of their ability to perform their required missions. [Ref. 8]

The end result is that the effort required to collect, embark and store these sustainment items is unnecessary when operating with MAGTFs because a reliable sustainment chain will have already been established before the Seabees arrive.

2. Footprint

The Seabees pay a severe penalty for the increased footprint that the large quantities of sustainment material create. Footprint needs to be considered both in the space it takes up during the embarkation phase, and also in the space the material occupies once the Seabees arrive in the area of operations. As Table 3-6 shows, more than 27% of the cubic feet of an Air Detachment's (Air DET) embarkation and slightly more than 20% of the cubic feet of an Air Echelon's embarkation must be devoted to sustainment items.

Upon arrival in the area of operations and once this equipment is staged for access and not just storage, the

footprint increases even further. Each of the categories of sustainment items requires significant space simply to store and manage. Instead of just establishing a base camp, the Seabees also have to establish places to manage rations, petroleum, oils, lubricants, ammunition, construction materials, medical resources (x-ray, surgical, dental), and common item repair parts that can be made available from the MAGTF.

Management of these sustainment items detracts from the Seabees preparation for their mission. When the NMCB is least prepared to manage sustainment material is the very same time when they are required to devote the most resources to the management of them. Instead of being able to outwardly focus on their mission, the NMCBs are forced to deal with the internal management of the considerable amount of sustainment material they have brought with them. [Ref. 8]

In some cases, the situation lessens as the sustainment items, such as food and petroleum products, are consumed and the Seabees begin using the MAGTF sustainment resources. In other cases the Seabees may well find themselves with unmanageable quantities of items such as explosives and ammunition, and therefore would require coordination with the MAGTF for storage purposes. [Ref. 11]

Class of Supply	Air DET (P25A)		Air Echelon (P25C)		Sea Echelon (P25D)	
	Cubic Feet Reqmt.	% of Tot. Lift Reqmt.	Cubic Feet Reqmt.	% of Tot. Lift Reqmt.	Cubic Feet Reqmt.	% of Tot. Lift Reqmt.
I	126	1.2	1,901	2.9	Not Planned	Does Not Apply
II	26	.24	752	1.1	2,826	Does Not Apply
III	1,824	17	8,622	13.1	Not Planned	Does Not Apply
IV	840	7.8	1,080	1.6	1,194	Does Not Apply
V	Class.	Class.	Class.	Class.	Class.	Does Not Apply
VI	Not Planned	Not Planned	Not Planned	Not Planned	Not Planned	Does Not Apply
VII	Does Not Apply	Does Not Apply	Does Not Apply	Does Not Apply	Does Not Apply	Does Not Apply
VIII	171	1.6	1,100	1.7	Not Planned	Does Not Apply
IX	Not Included	Not Included	Not Included	Not Included	Not Included	Not Included
X	Does Not Apply	Does Not Apply	Does Not Apply	Does Not Apply	Does Not Apply	Does Not Apply
TOTAL	2,987	27.7%	13,455	20.5%	2,945	Does Not Apply

Table 3-6. Sustainment Space Requirements by Class of Supply

Reliance on the MAGTF for sustainment immediately (with the exception of non-common Class IX repair parts) would allow the Seabees to greatly reduce their footprint, and concentrate their resources on the external mission at hand, vice internal housekeeping arrangements.

3. Class VIII (Medical) -- A Special Case

In keeping with their tradition of being exceptionally capable of independent operations, NMCBs have acquired organic medical and dental capabilities that far exceed their requirements when serving with MAGTFs. While regular Marine Corps battalions have an organic medical capability essentially consisting of advanced emergency first-aid and routine sick call requirements (Echelon 1), NMCBs have additional capability commonly referred to as Echelon 1(+). These increased capabilities include x-ray, surgical and dental capabilities. [Ref. 3]

The deleterious effects of the NMCB's excess capability are greatly magnified when the Seabees are operating with MAGTFs. The negative effects are manifested in unbalanced medical personnel assignments and the burden of maintaining a medical capability in excess of what is required by an organization of their size and mission. [Ref. 3]

a. Unbalanced Personnel Assignments

Table 3-7 compares the medical personnel assigned to an NMCB of approximately 750 personnel to a Marine Corps Engineering Support Battalion (ESB) of approximately 1100 personnel.

Grade	Military Occupational Specialty	Title	Number Assigned to NMCB		Number Assigned to ESB	
			Off	Enl	Off	Enl
03	2105	General Medical Doctor	1	0	1	0
03	2205	General Dental Officer	1	0	0	0
E7	8425/8404	Independent Duty Corpsman/FMF	0	1	0	1
E6	8707	FMF Dental Tech	0	1	0	0
E6	8425/8404	FMF Dental Tech	0	1	0	0
E5	8707	FMF Dental Tech	0	1	0	0
E5	8506	Lab Tech	0	1	0	0
E5	8432/8404	Preventive Med Tech/FMF	0	1	0	0
E5	8425/8404	Independent Duty Corpsman/FMF	0	1	0	0
E5	8404	FMF Corpsman	0	1	0	13
E5	0000	General Duty Corpsman	0	1	0	0
E4	8451/8404	X-Ray Technician/FMF	0	1	0	0
E4	8404	FMF Corpsman	0	1	0	0
E3	0000	General Duty Corpsman	0	1	0	0
Total			2	12	1	14

Table 3-7. Medical Personnel Assigned to NMCBs vs ESBs

While initially the number of medical personnel in an NMCB seems to be proportionately larger than the number of medical personnel assigned to an ESB, evaluation of their Military Occupation Specialties (MOS) shows that the NMCB is at a significant disadvantage in dealing with the everyday medical situations likely to be experienced in a general engineering support battalion. [Ref. 3]

The disadvantage results because the NMCB is designed to have a significant capability in many areas of medical and dental support (e.g., a physician, a dentist, an x-ray technician, and a lab technician), but at the sacrifice of proportionately lesser depth in the critical area of hospital corpsmen that can handle everyday medical requirements. This results in the NMCB being overstaffed for serious medical conditions and dental requirements, and understaffed for routine sick calls and general medical requirements when compared to a relatively equivalent Marine component of the MAGTF. [Ref. 3]

b. Medical/Dental Equipment

Sensitive medical equipment such as x-ray machines and the environmental requirements for surgery and dental work can cause the NMCB to be detracted from their core mission of providing general engineering support, and be inwardly focused on internal establishment of their base camp. [Ref. 3]

In the best case, these specialized pieces of equipment require extreme care in handling and environmental protection and provide little or no improvement in medical and dental care than could be provided directly from the MAGTF. As the Commander, Naval Construction Battalions,

U.S. Pacific Fleet stated in his letter to the Chief of Naval Operations (OP-44):

Many medical supplies in the TOA are geared to a surgically staffed battalion aid station. Battalions are staffed with general medical officers (GMOs) who are unable to perform surgery. Modern medical evacuation procedures provide quick access to fleet hospital and surgical support units. Certain items in the NMCB TOA (e.g., cranial and orthopedic surgery equipment) are only used by surgeons and are of no use to a battalion supporting a MEF. Deleting these extra items would reduce the weight and cube of the medical TOA to allow for other items either for medical or other battalion functions. [Ref. 12]

Conversations with medical personnel with the Second Naval Construction Brigade at Norfolk, Virginia have indicated that in the worst case, these specialized pieces of equipment require precious resources to be invested in attempting to create appropriate operating environments, but fail to perform effectively and NMCB personnel still end up relying on the MAGTF for advanced medical and dental requirements. [Ref. 3]

c. Footprint

Alignment of AMALs/ADALs to the equivalent of the MAGTFs ESB would result in a further reduction of the footprint of the NMCB, and increased mobility through not having to establish specialized environmental habitats for surgical and dental procedures. Table 3-8 shows the weight and space that the present NMCB organization requires. Table 3-9 shows the weight and space required by an ESB.

AMAL/ADAL	Title	Weight	Cube
0260	Air Echelon Dental	1,798 lbs.	139 cu.ft.
0305	Air Detachment Equipment	1,030 lbs.	117 cu.ft.
0306	Air Detachment Consumables	668 lbs.	53 cu.ft.
0307	Air Echelon Equipment	6,629 lbs	776 cu.ft.
0308	Air Echelon Consumable	2,563 lbs.	184 cu.ft.
TOTAL	NMCB AMALs/ADALs	12,689 lbs.	1,270 cu.ft.

Table 3-8. NMCB AMAL/ADAL Weight and Volume

AMAL/ADAL	Title	Weight	Cube
636	Aid Station Supply	1,232 lbs.	104 cu.ft.
637	Preventive Medicine Equipment	1,435 lbs.	92 cu.ft.
TOTAL	ESB AMALs	2,667 lbs.	196 cu.ft.

Table 3-9. ESB AMAL Weight and Volume

Comparison of the two tables shows that significant savings would be realized in both weight (embarkation lift requirement) and volume (footprint) if the NMCB were to adopt the AMAL allowance of an ESB, vice the AMAL/ADAL allowance they currently follow. The weight savings of slightly more than 10,000 pounds per NMCB saves almost an entire C-141B lift requirement for the four NMCBs normally supporting a MEF. Additionally, adoption of the ESB AMAL allowance would save more than 1,000 cubic feet of space, which results in a significant reduction in the NMCBs' footprint.

d. Cost Savings

Of additional significance is the several million dollars of savings that results from NMCBs being brought into line with ESBs for medical equipment. Table 3-10 below lists the Authorized Medical Allowance Lists (AMALS) and Authorized Dental Allowance Lists (ADALS) for an NMCB.

Table 3-11 shows the equivalent AMAL/ADAL list for an ESB.

Allowance List	Title	Qty	Dollar Value
#0260	NMCB Air Echelon Dental	1	\$51,837.00
#0305	NMCB Air Detachment (Equipment)	1	8,224.00
#0306	NMCB Air Detachment (Consumables)	1	27,730.00
#0307	NMCB Air Echelon (Equipment)	1	49,838.00
#0308	NMCB Air Echelon (Consumables)	1	121,501.00
TOTAL	NMCB AMALS/ADALS	5	\$269,130.00

Table 3-10. NMCB AMAL/ADAL Listing

Allowance List	Title	Qty	Dollar Value
636	Aid Station Supply	1	\$14,339.91
637	Preventive Medicine Equipment	1	18,004.96
TOTAL	ESB AMALS	2	\$32,344.87

Table 3-11. ESB AMAL Listing

The difference in dollar value for AMALS and ADALS for each NMCB is \$236,785 ($\$269,130 - \$32,345 = \$236,785$). With four NMCBs typically supporting a MEF, the savings

realized would be almost a million dollars. Total savings to the NCF would be almost five million dollars since there are 8 active and 12 reserve NMCBs. [Ref. 3]

These savings reflect the initial reduction in equipment and consumables. Even more significant savings would be realized over time through more effective utilization of medical personnel (especially physicians, dentists, x-ray technicians and laboratory technicians) and equipment (x-ray, surgical, and dental equipment). [Ref. 3]

Additional savings would be realized through greatly reduced requirements to manage items within the AMALs and ADALs. As medical personnel can attest, the management of delicate medical equipment and short shelf-life consumables within the AMALs/ADALs is a constant, demanding procedure that requires a great deal of time. Short shelf-life items that are not properly managed must be disposed of and then replaced at additional cost. Equipment that requires replacement through damage or obsolescence adds additional significant expense to the maintenance of AMALs/ADALs, without a corresponding increase in mission performance. [Ref. 8]

4. No Common Item Support

a. *Doctrine and Policy*

The TOR Agreement and more recent publications such as the FMFM 13-4/NWP 29-9 require that the Seabees establish and maintain their own Class IX (repair parts) sustainment. This requirement fails to take advantage of the tremendous potential for common item support available through the resources of the MAGTF.

A 1994 evaluation of a NMCB TOA by the 2nd Supply Battalion at Camp Lejeune, North Carolina, determined that more than 43% of the NSNs on the NMCB TOA were common to the Marine Corps. Since that time the Seabees have moved even further towards commonality with the Marine Corps with the decision to adopt the same standard service pistol, service rifle, and communication equipment suites. [Ref. 13]

The Combat Engineering Support Office (CESO) at Port Hueneme, California, is currently studying the TOAs to identify ways to improve commonality even further. Although commonality is not possible for many of the CESE items that are unique to the Seabees' engineering responsibilities (such as well drilling and asphalt laying equipment), there are many items the MAGTF is able to provide. [Ref. 8]

b. Procedure

Seabee procedure calls for utilizing a Seabee-unique microcomputer based system called MicroSNAP (Microcomputer Shipboard Non-Tactical Automated data Processing system) for creating requisitions for Class IX (Repair Parts) items. MicroSNAP provides Seabee units with the ability to create standard requisition formats that can be transmitted via satellite to the U.S. Navy facility supporting the unit, which then forwards the requisition to the appropriate source of supply. [Ref. 14]

Marine Corps units also utilize a microcomputer capable system, which they call ATLASS (Asset Tracking for Logistics and Supply System). Efforts by the Supply Department of the Third Naval Construction Brigade (NCB), Pearl Harbor, Hawaii, and the Operations Sections of the Supported Activities Supply System (SASSY) Management Unit (SMU) of 1st Supply Battalion at Camp Pendleton, California, have demonstrated the feasibility of MAGTFs providing common item support for Seabee units by utilizing MicroSNAP generated requisitions processed through ATLASS. [Ref. 15]

Tests performed in October and November of 1996 utilizing a small set of standard documents provided by the Third NCB to the 1st Supply Battalion SMU substantiated that identification of readily available common items can be

easily performed. This allows Seabee units serving with MAGTFs to have their requisitions initially screened by the MAGTF supporting supply detachment for common parts. [Ref. 15]

5. System Incompatibilities

Although the testing determined that providing common item support through the processing of standard requisitions was feasible, it did identify problems with the establishment of back orders and their status. The tests identified that the primary problem arises from format incompatibilities between MicroSNAP and ATLASS. Smaller problems are caused by the Marine Corps not being a registered user of many of the Seabee requested items, and also by the Marine Corps not recognizing NMCBs as authorized using units. None of these problems are insurmountable. [Ref. 15]

Ultimately, the Operations Section of the 1st Supply Battalion SMU hopes to be able to accept requisitions from Seabee units, fill requisitions for common items directly from stock on hand, and pass requisitions for non-common items directly through their supporting agencies to the appropriate source of supply. This will relieve the Seabees of seeking common item support from one source and then

establishing a separate sustainment chain for non-common items. [Ref. 15]

The problem of system incompatibility has also received attention at Headquarters Marine Corps (HQMC), Installations and Logistics, (Code LPS). The Information Systems Branch of that office is developing a future version of ATLASS that is intended to provide a common operating environment that would be compatible with all of the various services supply management systems. Conversations with ATLASS developers at the Information Systems Branch indicate they are working on a follow-on version of ATLASS that is intended to be able to function as a standard system compatible with all branches of the service. [Ref. 16] This new version will allow for processing of requisitions created by MicroSNAP within the ATLASS environment, including establishment of back orders and status. It is expected that this system will begin field testing in calendar year 1997. [Ref. 17]

IV. ALTERNATIVE SUSTAINMENT SUPPORT PRACTICES FOR NCF IN SUPPORT OF MAGTF OPERATIONS

A. STATUS QUO

There are three areas examined in this thesis that characterize logistics support for the Seabees: they are a robust organization in terms of medical support, they deploy with a robust initial sustainment capability, and when deployed with MAGTFs they depend on an independently established supply chain for Class IX support.

1. Robust Organization

The medical capability of a Seabee battalion exceeds that of a comparable battalion in the Marine Corps operating as part of a MAGTF. This extensive medical capability is appropriate for Seabee units that are operating independently of MAGTF support. When the Seabees are operating with MAGTFs this extended medical capability is not required for them to accomplish their assigned missions. Indeed, it is an expensive, heavy, manpower-intensive requirement that detracts from the accomplishment of their core general engineering missions. [Refs. 3 & 8]

2. Robust Sustainment

The Seabees deploy with extensive initial sustainment capability in Class I (Rations), Class II (General Supplies), Class III (Petroleum, Oils and Lubricants), Class

IV (Construction Materials), Class V (Ammunition) and Class IX (Repair Parts) supply items. This capability is critical in situations where the Seabees deploy without any established sustainment support available. [Ref. 18]

In the case of Seabees operating with MAGTFs however, initial sustainment capability is not required. In their role of providing general engineering support, the Seabees do not arrive in the area of operation until after the MAGTF has already established sustainment for all classes of supply. [Ref. 10]

Once again, a capability that is a critical requirement when the Seabees are operating independently becomes a liability when operating with MAGTFs. As Table 3-5 shows, sustainment material for the NMCBs in support of a MEF, not including Class IX (Repair Parts), requires the equivalent of more than 46 C-141B airlifts.

3. Independent Sustainment Chain for Class IX

When operating with MAGTFs, the Seabees receive Class I, Class II, Class III, Class IV, and Class V sustainment support from the MAGTF when their initial supplies are expended. In the case of Class IX (Repair Parts) items, the Seabees continue to establish a requisition and sustainment chain direct from themselves to the nearest supporting U.S. Navy facility. This facility passes requisitions to the

appropriate sources of supply. This is a practice that is carried over from Seabee procedures utilized when NMCBs operate independently. [Ref. 19]

This policy has two significant shortcomings: it does not allow the Seabees to take advantage of potential common items that are available from the MAGTF, nor does it take advantage of the extensive sustainment resupply chain that the MAGTF has already established.

B. ALTERNATIVE POLICIES AND ORGANIZATIONAL CHANGES

Throughout their history the Seabees have demonstrated they provide a critical and unique engineering capability to the U.S. Navy, Marine Corps and other agencies of the U.S. government. While history has shown the "Can Do" spirit of the Seabees will carry the day, it is a policy that can be inefficient. The Seabees can continue to provide a high capability of general engineering support without any changes to their policies or organization. As with any organization, however, there are improvements that can be made that could make the Seabees an even more viable engineering component in the mobile MAGTF force structures of the 21st Century.

The following paragraphs provide alternative policies or organizational changes that could allow the Seabees to maintain their present general engineering capabilities when

operating with MAGTFs, while enhancing their mobility, decreasing their footprint and making them an even more relevant force for the future.

- 1. Receive all sustainment from the Marine Corps with the exception of Non-Common Class IX (Repair Parts)**

The Seabee TOAs include thousands of pounds of sustainment items that are available directly from the MAGTF. To be able to take advantage of these items, the Seabees must only ensure that their requirements are coordinated with the MAGTF they are operating with. [Ref. 15]

Although a few days of sustainment supplies are a significant burden to the Seabees as they deploy, for the MAGTF they would be just another small piece of the larger sustainment chain they would already have established. The additional burden of providing sustainment to the Seabees as soon as they arrive would not be a significant problem to the MAGTF since their sustainment chain would already be in place. [Ref. 15]

The Seabees could receive several benefits from this change. An immediate benefit would be that it would greatly simplify their preparations for embarkation. Sustainment items are generally the most challenging items to prepare for embarkation. Most of the sustainment material needs to

first be collected before it can be prepared for embarkation. By eliminating sustainment items from their embarkation requirements, the Seabees would be able to concentrate on the preparation of their personnel and equipment. [Refs. 8 & 11]

An additional benefit of not taking the more than 500,000 pounds of sustainment material with them would be that the Seabees could realize greater mobility. Instead of being concerned with where to store their sustainment items, they would be able to focus on their personnel and equipment. While much of the sustainment material would be consumed in a matter of days and would not be a lingering burden, some material, especially ammunition, would be a burden until it is expended or turned into an established Ammunition Supply Point (ASP) for storage. In either case, the Seabees would be better off embarking only the minimum basic load prescribed by the MAGTF commander and drawing resupply as required from the MAGTF.

Another significant advantage the Seabees would realize by not deploying with initial sustainment would be a greatly reduced footprint. When first arriving into an area of operations, secure areas can be at a premium. Seabee sustainment items as planned require more than 15,000 cubic feet of storage area. Of greater concern is that this

figure does not include the obvious additional areas that would be required to allow separate storage areas for items such as rations, petroleum, oils, lubricants, and explosives. Management of such a large area of sustainment supplies requires considerable resources in both planning and execution. [Ref. 8]

2. Realign Medical Capability

A Seabee unit's medical capabilities do not match their requirements when operating with MAGTFs. During independent operations, the Seabees must have access to medical and dental support in many situations. When operating with MAGTFs, these resources are readily available from the Medical and Dental Battalions of the Force Service Support Groups. [Ref. 3]

Seabee medical sections should be organized similar to equivalent Marine Corps units. As the comparison in Table 3-7 demonstrates, Marine Corps engineer battalions in the Force Service Support Group (FSSG) are not assigned dentists on their Table of Organization (T/O) and have a heavier compliment of general duty corpsmen. Although Marine Corps engineer support battalions are assigned physicians on their T/O's, in many cases these physicians fill a general support role within the Combat Service Support Element (CSSE) and do

not physically operate with the engineer support battalion.

[Ref. 20]

As currently manned, NMCBs are provided physicians, dentists and technicians at the expense of general duty corpsmen. In virtually all situations, a general duty corpsmen could provide more utility to the NMCB than a physician, a dentist and a few technicians to care for equipment. Through strength in numbers the additional corpsmen could increase the availability and quality of sick call and preventive medical programs to the Seabees. In those cases where a physician or dentist is required, the Seabees would be able to receive support from the same physicians and dentists that the MAGTF does. [Ref. 3]

The Seabees would also recognize a significant improvement in their unit's mobility. Medical equipment, such as x-ray machines and surgical units, must be handled carefully and requires special operating conditions [Ref. 3]. As Table 3-8 and Table 3-9 show, medical and dental equipment and supplies for an NMCB weigh over 10,000 pounds more than that in a comparable Marine Corps battalion. Table 3-8 and Table 3-9 also show that the NMCB requires more than 1,000 additional cubic feet of footprint space than a comparable Marine Corps battalion does. [Ref. 8]

3. Request Common Item Support from MAGTF

As previously discussed in Chapter III, ATLASS has the ability to process requisitions created in MicroSNAP to identify any available common items held by the MAGTF. [Ref. 15] To benefit from these MAGTF-held common items the Seabees only need to submit their MicroSNAP generated requisitions to the MAGTF's deployed supply support unit. Available common items would be recognized by the MAGTF and provided to the Seabees. Those items either not available or requiring a back order would be returned to the Seabees for submission through the normal U.S. Navy supply chain. [Ref. 15]

4. Adopt Marine Corps' ATLASS

The current system compatibility problems that were discussed in Chapter III do not allow the Seabees to utilize MicroSNAP to establish back orders through the MAGTF, nor do they allow the MAGTF to provide status for back orders to the Seabees. These problems can be eliminated by the Seabees adoption of the Marine Corps ATLASS when operating with MAGTFs.

Adoption of ATLASS as an adjunct system with MicroSNAP would allow the Seabees to submit all of their requisitions for processing through the MAGTF. In addition to receiving common item support, the Seabees would benefit from the

extensive logistic support chain the Marine Corps has already established to provide for resupply of non-available items. This would greatly reduce the logistical problems the Seabees have in trying to establish their own logistic chain for back ordered items from their Construction Battalion Centers (CBCs) in Gulf Port, Mississippi, and Port Hueneme, California. Experience from Operations Desert Shield, Desert Storm, and Restore Hope has shown that the Seabees are at a significant disadvantage when competing with the other services for strategic lift of supplies. Because of the limited number of items they require for sustainment compared to other organizations the Seabees are not able to reserve dedicated air lift support. By coordinating resupply of back orders directly with the MAGTF the Seabees would gain the benefits of the already established MAGTF logistic chain and not have to compete with the other services for the limited lift support.

[Refs. 8 & 19]

Also of significance is that Seabee requisitions would be prioritized in accordance with the MAGTF commander's directives if the Seabees utilized ATLASS. Rather than have Seabee requisitions competing with Navy organizations, they would be competing with other equivalent components of the MAGTF. [Ref. 15]

The drawbacks of this approach are two-fold. First, it would require additional training of personnel. Second, utilizing two systems would complicate the management of requisitions and increase the likelihood of errors.

The first problem is mitigated by the recognition that the Seabees only need to use the requisitioning based modules of ATLASS, which can be nominally learned in a matter of several hours [Ref. 16]. Additionally, assistance would be readily available from the MAGTF supply support unit [Ref. 15].

The second problem can be mitigated by conscientious management procedures. Although it is an additional management burden, the benefits of gaining the support of the MAGTF supply chain should outweigh the additional management burdens caused by having an additional system.

V. CONCLUSIONS AND RECOMMENDATIONS

A. CONCLUSIONS

Historical ties between the Seabees and the U.S. Marine Corps have always been strong, and are growing even stronger. In previous years a weak argument could be made that much of what the Seabees did simply duplicated what Marine Corps engineer units did. With the era of downsizing and reengineering upon us, this is clearly no longer the case.

More than ever, the Marine Corps depends on the Seabees to be a critical and complimentary engineering component of the MAGTF. With much of the Marine Corps engineer capability lost through force reduction, the Marine Corps now looks directly to the Seabees to fill the void.

The Seabees are now actively included in operations plans for major contingencies. Two critical engineer missions required by the MAGTF are now the responsibility of the Seabees: disassembly and transportation of mobile bridging assets to forward areas for re-emplacment by Marine engineers, and expansion of Expeditionary Airfield runway aprons. These missions are in addition to the general engineering responsibilities the Seabees have always had, such as well drilling and asphalt laying. [Refs. 2 & 10]

With the Seabees now playing a critical role in the MAGTF, their ability to effectively operate in the same environment as their Marine counterparts is crucial as well. Being mobile and maintaining a minimal footprint are two of the prime considerations for expected success in future contingencies. [Ref. 2]

Inclusion of sustainment items in the Seabees Tables of Allowance (TOA) when deploying with MAGTFs decreases the Seabees mobility and increases their footprint. In most cases, equipment designated for the Air Echelon is relegated to a Sea Echelon, simply because the aircraft lift requirements for an NMCB are so great. [Ref. 8]

Elimination of these sustainment items would reduce the lift requirements of the NMCB by almost 10%, or the equivalent of almost 12 C-141B aircraft per NMCB. With four NMCBs notionally assigned to each MEF, the MEF aircraft lift requirement for the Air Detachments and Air Echelons would be reduced more than 46 C-141B aircraft loads. However, it is likely that much of this material would be relegated to sea lift because of the overall weight of an NMCB and the limited aircraft lift that would be available. This point provides even greater reason for seeking ways to efficiently reduce the lift requirement for Seabee units.

Of equal concern is the significant footprint associated with managing these sustainment items. While the sustainment items approximate 10% of the weight of an NMCB, they occupy more than 27% of the volume. This expands the footprint of the NMCB significantly. The footprint effect for sustainment items can actually be expected to be even greater than the cubic volume they occupy for embarkation purposes. Rations, POL, and explosives all require special storage considerations. In contingencies where secure areas are at a premium, the space these items require is one more challenge that works to detract from the Seabee's primary mission of general engineering support.

Additional efficiencies could be gained from providing common item support for those Class IX (Repair Parts) items that are available from the MAGTF. While a standard DoD supply support system is not yet available, cooperation and coordination could minimize the impact of an imperfect system until a viable standard system is available. [Ref. 15]

B. RECOMMENDATIONS

1. MAGTFs Provide Seabees All Sustainment Except Non-Common Class IX (Repair Parts)

This recommendation is virtually identical to present doctrine with the critical exception that it does not require the Seabees to deploy with several days of

sustainment in several classes of supply. Providing sustainment for Seabees operating with the MAGTF is a responsibility the Marine Corps has accepted. Whether this requirement begins the day the Seabees arrive to the area of operations, or five days later does not significantly alter the sustainment support requirements for the MAGTF. [Ref. 15]

It must also be recognized that the Seabees could still be faced with contingencies where they may not be operating with the support of MAGTFs and would be required to deploy with substantial levels of sustainment. [Ref. 18]

2. Reorganization of Medical Section

The Seabees clearly have a requirement for medical and dental support when operating independently from other supporting agencies. When operating with MAGTFs, however, the extensive medical and dental capabilities of each NMCB equips them well for major medical events, but poorly for routine sick call and preventive medicine requirements. [Ref. 3]

Alignment in accordance with a comparable Marine Corps organization such as an Engineer Support Battalion would free up physicians and dentists to the field medical facilities, and eliminate the requirement for the Seabees to

manage surgical and dental equipment in often imposing environmental conditions. [Ref. 3]

3. Conduct Field Testing of Marine Corps' ATLASS to Determine its Suitability for Use with Seabees Operating with MAGTFs

This recommendation has potential near-term and long-term benefits. In the near-term, ATLASS offers an immediate opportunity for the Seabees to benefit from the extensive supply support chain that the MAGTF establishes. In addition to common item support, the Seabees would be able to have requisitions passed to the appropriate source of supply by the MAGTF without the need to resubmit the requisition through the Navy. [Ref. 15]

In the long-term, a follow-on version of ATLASS promises to provide the potential to meet the requirements of the Marines and the Seabees for a standard system. Seabee familiarity with an earlier version of ATLASS would allow for an informed evaluation of the abilities of the ATLASS system when the follow-on version does arrive. [Ref. 17]

4. Aggressively Pursue Field Exercises with MAGTFs

The relationship between the Seabees and MAGTFs continues to evolve and be refined almost daily. Just as the Marine Corps is adjusting to the reduction in its organic engineer capabilities, the Seabees are adjusting to

their new position as a crucial component of the MAGTF engineer mix. While Seabees deploy extensively as independent battalions, participating in field exercises with actual MAGTFs could provide valuable experience to both the Seabees and the MAGTF concerning how to best operate together.

C. RECOMMENDATIONS FOR FURTHER STUDY

1. Optimum Organization of Naval Construction Forces Operating with MAGTFs

The success of the Seabees over the years can largely be attributed to the extensive planning and preparation they have employed in the ABFCs and TOAs, and as exhibited by each battalion being assigned a physician and a dentist. While these systems are excellent tools for independent operations with known mission requirements, they appear to be inappropriate for the roles and missions Seabees could be expected to fill when operating with MAGTFs. A careful evaluation of the organization of an NMCB may identify other areas where the Seabees have an excess or inappropriate capability for their missions with MAGTFs.

2. Dedicate Selected NMCBs to Support of MAGTFs

Each NMCB is challenged by their peacetime missions which require substantial independent capabilities, and by their contingency missions with the Navy, Marine Corps or other DoD agencies. The Marine Corps routinely meets such

challenges by "task organizing" to meet the requirements at hand. For the Marine Corps, "task organizing" is simply identifying the requirements for a task or mission and organizing appropriately for the mission by piecing together the required components from all of the units. This provides the Marine Corps great flexibility in adjusting to any possible contingency. The Seabees, because they are a small, unique part of the U.S. Navy, cannot call upon other organizations within the Navy to support them when they are called to a mission. The question is, since all of the services have been subject to severe cutbacks in personnel and resources, might it be prudent to task some NMCBs with the primary responsibility of training for, and supporting MAGTF operations? These units could potentially be leaner in personnel and equipment, and specifically organized to support those missions associated with the MAGTF's requirements. Other NMCBs could remain robust and capable of extensive independent operations.

3. Optimum Commonality of Equipment

As a result of their years of independent assignments, the Seabees have assembled a unique collection of civil engineering support equipment. In a "joint" world where each of the services is responsible for supporting or is dependent on the support of other branches at one time or

another, uniqueness is a significant liability. Evaluation of the Seabees' civil engineering support equipment could identify those areas where common equipment could be employed and still meet their mission requirements.

APPENDIX A. COMPARISON OF ENGINEERING CAPABILITIES

LEGEND OF TASK PRIORITY AND CAPABILITY CODES

First Letter: P Primary Task Responsibility
 Second Letter: S Secondary Task Responsibility

H Heavy Capability
 M Medium Capability
 N Not an assigned Task
 L Light Capability
 N No Capability

TASKS, CAPABILITIES, AND SOURCES OF SUPPORT

GENERAL ENGINEERING TASKS (CSS)	<u>NCF</u>	<u>CEB</u>	<u>ESB</u>	<u>MWSS</u>	<u>CIV</u>
Conduct Engineer Reconnaissance	PM	SM	PM	PL	PM
Surveying and Drafting	PH	SL	PM	PL	NL
Plan Construction/Repair/Maintenance of Camps	PH	SL	PH	PM	SL
Improve Beaches	PH	SL	PH	NL	NN
Construct Standard/Nonstandard Bridges	PH	SL	PH	NN	NL
Improve Unpaved Roads/Airstrips/Marshaling Areas	PH	SL	PH	SL	NM
Perform Rapid Runway Repair	PH	NN	SM	PM	NL
Repair/Improve Bare Base Existing Airfields	PH	NN	PH	PM	NH
Build Expedient Airfields (Matting)	PH	NN	PH	SL	NN
Plan and Estimate Projects	PH	PM	PH	PM	PM
Materials Testing (Engineering Properties)	PH	SL	PM	PL	PH
Soil Stabilization	PH	SL	PH	PL	NM
Construct Aircraft Revetment/Dispersal Sites	PH	NL	SH	PM	NL
Repair Airfield Damage	PH	NL	PH	PM	SM
Engineering Design (Deliberate)	PH	NL	PH	SL	SM
Perform Pile Driving Operations	PM	NN	PM	SL	SM
Repair War Damage	PH	NL	NM	NL	PM
Drill Wells	PH	NN	NN	NN	SM
Construct Semi-Permanent Camps	PH	NL	PH	SL	SM
Erect Pre-Engineered Structures	PH	NL	PH	PL	SM
Construct Hard-Surfaced Storage/Staging/Marshaling Areas	PH	NN	NN	NN	SL
Perform Vertical Construction (Including Concrete)	PH	NL	PM	PL	SM
Asphalt Roads	PH	NN	NN	NN	SM
Operate Base Central Power Plants	PM	NN	NN	NN	SM
Perform Base Maintenance	PH	NL	SM	SL	SM
Concrete Production Operations	PH	NN	NL	NL	SM
Asphalt Production Operations	PH	NN	NN	NN	SM
Perform Quarry Operations	PH	NL	SM	NL	SM
Perform Rock Crusher Operations	PH	NN	SM	NN	SM
Construct Logistical Support Bases	PH	NL	PH	NL	SM
Construct Airbases	PH	NN	PH	NN	PM
Construct/Repair Port/Waterfront Structures	PH	NL	NM	NL	PM

	<u>NCF</u>	<u>CEB</u>	<u>ESB</u>	<u>MWSS</u>	<u>CIV</u>
GENERAL ENGINEERING TASKS (CSS) (cont.)					
Employ Specialized Demolitions	NL	PH	SH	NL	NN
Conduct Nonexplosive Demolition and Obstacle/Debris Removal	PH	NL	PH	NL	PH
Provide Technical Engineer Advice	PH	NL	PH	PM	PH
Fight as Infantry	SL	NM	SL	NN	NN
Provide Tactical Water/Hygiene Services	SL	SL	PH	PM	NL
Provide Tactical Electrical Service	SM	SL	PH	PM	NN
Develop Sewage and Water Systems	PM	NN	NL	NL	PM
Provide Tactical Bulk Fuel Storage/Dispensing	PH	NN	PH	PM	SL
MILITARY TASKS (CS)					
Conduct Engineer Reconnaissance	NL	PM	PM	PL	NN
Breach Obstacles	NL	PH	SM	NL	NL
Construct Pioneer Roads	SH	PH	SH	SL	NL
Assault Bridging	NN	PL	SL	NN	NN
Clear Mines	NN	PH	SH	SL	NN
Clear Helicopter Landing Sites	SH	PM	PH	SL	NL
Improve Beaches	PH	PH	SH	NN	NN
Employ Specialized Demolitions	SM	PH	SH	NL	NN
Provide Technical Engineer Advice	SH	PH	NH	PH	NN
Fight as Infantry	NL	SM	NL	NN	NN
COUNTERMOBILITY TASKS (CS)					
Conduct Engineer Reconnaissance	NL	PM	PM	PL	NN
Place Mines	NN	PH	SH	SL	NN
Plan/Install Obstacles and Barriers	SL	PH	SH	SL	NN
Employ Specialized Demolitions	NL	PH	SH	NL	NN
Provide Technical Engineer Advice	SH	PH	SH	PH	NN
Fight as Infantry	SL	SM	NL	NN	NN
SURVIVABILITY TASKS (CS)					
Construct Field Fortifications	SH	PH	PH	PM	NL
Employ Specialized Demolitions	SM	PH	PH	NL	NN
Provide Technical Engineer Advice	NL	PH	PH	PH	NN

APPENDIX B. CLASSES OF SUPPLY

Class I

Subsistence including gratuitous health and welfare items.

Subclassifications for class I are:

- A-air (in-flight rations)
- R-refrigerated subsistence
- S-non-refrigerated subsistence (less combat rations)
- C-combat rations (including gratuitous health and welfare items).

Class II

Clothing, individual equipment, tentage, organizational tool sets and tool kits, hand tools, administrative and housekeeping supplies and equipment.

Subclassifications for class II are:

- B-ground support material
- E-general supplies
- F-clothing and textiles
- M-weapons
- T-industrial supplies (including bearings, block and tackle, cable, chain, wire rope, screws, bolts, studs, steel rods, plates, and bars).

Class III

Petroleum, oils, and lubricants; petroleum fuels, lubricants, hydraulic and insulating oils, preservatives, liquid and compressed gases, bulk chemical products, coolants, deicing and antifreeze compounds, together with components and additives of such products; and coal.

Subclassifications for class III are:

- A-air
- W-ground (surface)

Class IV

Construction: construction materials to include installed equipment and all fortification/barrier materials.

No subclassifications.

Class V

Ammunition: ammunition of all types (including chemical, biological, radiological, and special weapons), bombs, explosives, mines, fuzes, detonators, pyrotechnics, missiles, rockets, propellants, and other associated items.

Subclassifications for class V are:

A-air
W-ground.

Class VI

Personal demand items (nonmilitary sales items).

No subclassifications.

Class VII

Major end items: a final combination of end products which is ready for its intended use, e.g., launchers, tanks, mobile machines shops, and vehicles.

Subclassifications for class VII are:

A-air
B-ground support material (includes power generators and construction, barrier, bridging, fire fighting, petroleum, and mapping equipment)
D-administrative vehicles (commercial vehicles used in administrative motor pools)
G-electronics
K-tactical vehicles
L-missiles
M-weapons
N-special weapons

Class VIII

Medical material including medical unique repair parts.

Subclassifications are:

- A-medical/dental material, less blood and blood products
- B-blood and blood products

Class IX

Repair parts and components to include kits, assemblies and subassemblies, reparable and nonreparable, required for maintenance support of all equipment.

Subclassifications for class IX are:

A-air

B-ground support material (includes power generators and construction, barrier, bridging, fire fighting, petroleum, and mapping equipment)

D-administrative vehicles (commercial vehicles used in administrative motor pools)

G-electronics

K-tactical vehicles

L-missiles

M-weapons

N-special weapons

T-industrial supplies (includes bearings, block and tackle, cable, chain, wire rope, screws, bolts, studs, steel rods, plates, and bars).

Class X

Material to support nonmilitary programs, e.g., agricultural and economic development, not included in classes I-IX.

No subclassifications.

LIST OF REFERENCES

1. Department of the Navy, Naval Doctrine Command, *Naval Civil Engineering Support of MAGTF Operations*, Naval Warfare Publication 4-04.1/Marine Corps Reference Publication 4-5.4 DRAFT, Norfolk, VA, 1996.
2. Interview between W. L. Rudich, Captain, USN, 31st Naval Construction Regiment, Port Hueneme, CA and author, 25 September 1996.
3. Interviews between D. L. Fabrao, HMCS, USN, 2nd Naval Construction Brigade, Norfolk, VA and author, October - December 1996.
4. Department of the Navy, *Naval Facilities Engineering Command*, Naval Construction Force Manual P-315.
5. McGill, Michael J., Major, USMCR, and Robertson, Al, Commander, USNR, "Seabees-A Force Multiplier," *Marine Corps Gazette*, March 1996.
6. Marine Corps Combat Development Command, *Naval Construction Force Support of MAGTF Operations*, Fleet Marine Force Manual 13-4, Quantico, VA, 1991.
7. Third Naval Construction Brigade, *Logistics Support for the Naval Construction Force, ABFC/TOA Introduction*, Seabee Logistics Training Guide Series Module #2, Pearl Harbor, HI, 1996.
8. Interviews between W. Frederick, Table of Authorization Manager, Third Naval Construction Brigade, Port Hueneme, CA and author, June - December 1996.
9. Marine Corps Combat Development Command, *Combat Service Support Operations*, Fleet Marine Force Manual 4-1, Quantico, VA, 1993.
10. Interviews between D. G. Hutchins, Lieutenant, USN, Naval Construction Force Liaison Officer, G-4 Engineers, First Marine Expeditionary Force, Camp Pendleton, CA and author, September - November 1996.

11. Interview between M. Tufts, Lieutenant, USN, Readiness Officer, 31st Naval Construction Regiment, Port Hueneme, CA and author, October 1996.
12. Commander, Naval Construction Battalions, U.S. Pacific Fleet Letter 1310 Ser CB30/067 to Chief of Naval Operations (OP-44), Subject: Naval Construction Force Support of Operation Desert Shield/Storm, 23 January 1992.
13. Deputy Director, Logistics Plans & Operations Branch, Commandant of the Marine Corps (Code LPO) Memo, Subject: USMC/NCF Interoperability Working Group, 23 May 1996.
14. Interviews between J. Miller, Commander, USN, Assistant Chief of Staff for Logistics (N4), Third Naval Construction Brigade, Pearl Harbor, HI and author, June - November 1996.
15. Interviews between D. Turlip, Major, USMC, Operations Officer, SASSY Management Unit, 1st Supply Battalion, 1st Force Service Support Group, Camp Pendleton, CA and author, June - November 1996.
16. Interview between D. Lick, Chief Warrant Office - 4, USMC, Program Developer, Information Systems Branch, Installations and Logistics, Headquarters, Marine Corps (Code LPS), Quantico, VA, October 1996.
17. Interview between R. Rackham, Major, USMC, Program Developer, Information Systems Branch, Installations and Logistics, Headquarters, Marine Corps (Code LPS), Quantico, VA, December 1996.
18. Interview between N. Linkowitz, Deputy, Logistics Plans & Operations Branch, Headquarters, Marine Corps (Code LPO), Washington, DC November 1996.
19. Interview between G. Rosado, Commander, USN, Assistant Director, Civil Engineering Support Office, Naval Construction Battalion Center, Port Hueneme, CA and author, 25 September 1996.
20. Interview between D. Poore, HMC, USN, 7th Engineer Support Battalion, 1st Force Service Support Group, Camp Pendleton CA, December 1996.

INITIAL DISTRIBUTION LIST

1. Defense Technical Information Center 2
8725 John J. Kingman Road, Ste 0944
Ft. Belvoir, VA 22060-6218
2. Dudley Knox Library 2
Naval Postgraduate School
411 Dyer Rd.
Monterey, CA 93943-5101
3. Director, Training and Education 1
MCCDC, Code C46
1019 Elliot Rd.
Quantico, VA 22134-5027
4. Director, Marine Corps Research Center 2
MCCDC, Code C40RC
2040 Broadway Street
Quantico, VA 22134-5107
5. Director, Studies and Analysis Division 1
MCCDC, Code C45
300 Russell Road
Quantico, VA 22134-5130
6. Defense Logistic Studies Information Exchange 1
U.S. Army Logistics Management College
Fort Lee, VA 23801-6043
7. Paul J. Fields, Code SM/FP 1
Department of Systems Management
Naval Postgraduate School
Monterey, CA 93943-5002
8. Kevin R. Gue, Code SM/GK 1
Department of Systems Management
Naval Postgraduate School
Monterey, CA 93943-5002
9. Commander John D. Miller, SC, USN 5
Assistant Chief of Staff for Logistics (N4)
Third Naval Construction Brigade
Pearl Harbor, HI 96860-7305

10. Walt Frederick 1
TOA Manager, Third NCB
4341 Justin Way
Oxnard, CA 93033
11. Lieutenant Dan Hutchins, CEC, USN 1
G-4 Engineers, I MEF
Camp Pendleton, CA 92055
12. HMC D. L. Fabrao 1
Second Naval Construction Brigade
1310 8th Street, Suite 100
Norfolk, VA 23521-2435
Attn: Medical
13. Major Doug Turlip 1
SMU Operations
1st Supply Battalion, 1st FSSG
Camp Pendleton, CA 92055
14. Major Michael Loudy 1
1940 Georgia Ave.
Albany, GA 31705