

FARM CROPS

C.W. BURKETT



Class SB185

Book B95

Copyright N^o _____

COPYRIGHT DEPOSIT.







HARVESTING CORN

Farm Crops

A Practical Treatise on the Growing of American Field Crops: Containing Brief and Popular Advice on the Seeding, Cultivating, Handling and Marketing of Farm Crops, and on the Management of Lands for the Largest Returns

By
CHARLES WILLIAM BURKETT

Editor of American Agriculturist



ILLUSTRATED

NEW YORK
ORANGE JUDD COMPANY
1910

SB185
B95

Copyright, 1910
ORANGE JUDD COMPANY
NEW YORK

PRINTED IN U. S. A.



P R E F A C E

IN the aggregate the farmer's annual wealth is nearly \$9,000,000,000. Last year it was \$869,000,000 above that of 1908, \$1,159,000,000 above that of 1907, \$1,023,000,000 above that of 1906, \$1,469,000,000 above that of 1905, \$1,619,000,000 above that of 1904, \$1,861,000,000 above that of 1903 and \$3,061,000,000 above the census year of 1899. In a decade the value of farm products has doubled. Too frequently national prosperity is gauged by the activities of the cities. Extend Broadway across the continent and broaden it until the Canadian border is touched and carry the same construction to the Gulf and in six months if agriculture be abandoned, as it necessarily would be, the buildings would be tenantless, the banks would be doing no business and just about all the people either would be dead or starving. Much of our national greatness, therefore, is dependent upon the kind of crops raised and upon their average acre yield.

This book is concerned with the field crops raised on American farms. It contains the best ideas gathered from various authorities and the experience of many practical men in all lines of crop production. The illustrations that accompany the text have been selected for their instructional value. All of the drawings have been made by Mr. B. F. Williamson, to whom grateful appreciation is expressed.

C. W. BURKETT.

New York, July, 1910.

Table of Contents

| | Page |
|---|------|
| INTRODUCTION | |
| Growing Crops Our Greatest Business | I |
| CHAPTER I | |
| Good Soils Back of Good Crops | 4 |
| CHAPTER II | |
| How Rotations Help Out | 16 |
| CHAPTER III | |
| Getting the Seed Bed Right | 27 |
| CHAPTER IV | |
| Crop Yields and Proper Culture | 35 |
| CHAPTER V | |
| What Crops for Feeding | 43 |
| CHAPTER VI | |
| What Forage Crops Are Best | 54 |
| CHAPTER VII | |
| Growing Crops for Succulence | 63 |
| CHAPTER VIII | |
| The Silo, Silage and Soiling Crops | 75 |
| CHAPTER IX | |
| Every Farmer a Plant Breeder | 84 |
| CHAPTER X | |
| Farm Crops | 95 |

List of Illustrations

| | Page |
|--|------|
| How Good Drainage Works | 5 |
| How Bad Drainage Handicaps | 7 |
| Increasing Potato Yields | 10 |
| Fertilizing the Cowpea | 13 |
| Meadow Fescue and Brome Grass | 18 |
| Blue Grass | 20 |
| Meadow Foxtail | 22 |
| Peg-Tooth Harrow | 31 |
| Header and Thresher | 33 |
| Wheat Harvester | 36 |
| Corn Cultivator | 40 |
| Two-Row Corn Cultivator | 41 |
| Beggar Weed | 44 |
| Corn Kernels | 47 |
| A Soil in Need of Nitrogen | 55 |
| Orchard Grass in Bloom | 66 |
| Yellow Globe Mangel | 70 |
| A Good Silo | 76 |
| Improving Cotton | 85 |
| Six Ears to the Stalk | 86 |
| Corn Smut | 87 |
| Seed Corn Room | 90 |
| Improvement of Corn by Selection | 91 |
| Effect of Inbreeding of Corn | 94 |
| Alsike Clover | 103 |

| | Page |
|--------------------------------------|------|
| Beggar Weed | 108 |
| A Field of Broom Corn | 112 |
| Carrot | 117 |
| Crimson Clover | 121 |
| Shocking Corn | 124 |
| Corn Cultivator | 125 |
| Shocking Corn | 130 |
| Shocking Corn by Machinery | 132 |
| Shocking Corn | 136 |
| Upland Cotton | 137 |
| Cotton Boll | 138 |
| Cotton Boll | 142 |
| Cowpea Rack | 145 |
| Cowpea Shock | 146 |
| Durum Wheat | 148 |
| Hop Culture | 154 |
| Kentucky Blue Grass | 161 |
| The Sugar Mangel | 164 |
| Meadow Foxtail | 166 |
| Orchard Grass | 179 |
| The Potato Underground | 185 |
| Potato Tray | 187 |
| Rape Plant | 195 |
| Common Red Clover | 198 |
| Red Top | 203 |
| Threshing Rice | 206 |
| Sheep's Fescue | 215 |
| The Soy Bean | 219 |
| Sugar Beet | 225 |

LIST OF ILLUSTRATIONS

xi

| | Page |
|---|------|
| Sugar Cane; Laying the Cane | 231 |
| Taller Fescue | 236 |
| Tall Oat Grass | 237 |
| Tobacco | 243 |
| Turnip | 247 |
| Velvet Bean | 249 |
| Velvet Grass | 251 |
| Hairy Vetch | 252 |
| Wheat Production in United States | 254 |
| Wheat Header | 256 |

INTRODUCTION

Growing Crops Our Greatest Business

Compared with Europe and Asia the United States is a young nation and our agricultural operations still in their infancy. While development has been rapid and on a broad scale, it has gone on roughly without regard to permanency; crops have been raised without thought as to the effect upon the soil; great quantities of produce have been secured regardless of efficiency or quality and old methods have been followed without interest in any change that might mean a higher state of land culture, a greater acre yield of field, orchard and garden crops, or a more economical production of animal products.

American agriculture has been of a shifting nature. The early settlers introduced many desirable European plants to be used in addition to those native here; they brought live stock from across the water and these were raised on every individual farm. As a result, on every farm the entire needs of the home were raised or made in the household. The farmer not only raised the raw materials but manufactured everything that was needed for his own use. In time this concentrated effort gave way to diversification; and a division of labor resulted. The canal came, soon to be followed by the railroad and then later by every kind of transportation power. Agricultural industries became segregated or separated or fixed as the nature of the soil or climate or location demanded.

Towns and cities sprang into existence. They called for food and for raw materials and in exchange gave finished products for the home, tools and machines for the farm, and luxuries for the family. From growing every sort of crop, making his own clothing and supplying his own needs, the farmer altered the program, giving way to specialization. He cultivated his fields and raised his animals, and from the surplus, after meeting his own needs, he secured his additional supplies from the manufacturing centers of the cities and towns. In time sections became marked as being peculiarly adapted for certain lines of crop production, and these became centers of supply, giving rise to exchange, not only between town and city, but between agricultural localities also. For instance, sugar became a fixture in one section, cotton in another, tobacco in another, corn shifted to the South and Middle West, wheat to the uttermost limits both north and west, while live stock settled itself where opportunity offered it the best prospects.

Thus sheep departed from New England into Ohio, then into the far West and Southwest. Beef cattle sought the rich pasture lands in the Middle and Western states. The hog followed after corn and established himself where corn, clover and alfalfa were most at home. Dairy cattle, mindful of the worth and possibilities of settled communities, congregated around cities and towns, and, undaunted by heat, snow or cold, or regardless of scant and rocky pasture or diminishing returns in hay and forage, became fixed in New England and the older sections of the country. At the same time, farm poultry, wedded to woman and the home, so fixed themselves through sentiment and

beneficent use as to become a home necessity in every section, state and community, developing all the time until their annual worth in eggs and meat was to become nearly twice the annual gold output of the entire world for a single year.

American farms, together with all improvements contained thereon, with crops, live stock and all other things included, possess a total value of more than \$36,000,000,000. During the last year the farmers of the United States produced farm products having a value of more than \$8,000,000,000; they received more than \$1,000,000,000 for the farm products sent out of the country. Since the farm products imported for the use of the entire nation amounted to but \$600,000,000, there remained in favor of this country a total of more than \$400,000,000 as a result of the exchange.

The legend of Antæus, whom Hercules could not overthrow so long as his opponent had his feet upon the ground, is applicable to the farming population of the United States. This vast body of men has its foundation upon the land; among them are found the loftiest patriotism, the sturdiest character and the highest integrity—all of which conduce to greater growth, to larger development and to more wonderful returns than can possibly be indicated by any production of the past.

CHAPTER I

Good Soils Back of Good Crops

The soils of the United States are as diverse as the people that live on them. They vary greatly in origin, in composition and in productive power. They are subject to change, and respond to good treatment or suffer from inattention or neglect. On every side even a casual observer sees soils that once abounded in fertility, but are now so depleted that they barely pay the cost of seed and tillage. Other soils, that inherited poverty through generations of thriftless ownership, are now known for their high productive power.

THE SUPREME TEST OF THE FARMER

Ability to make soil produce is the test of good farming. Without this ability, ideal climate, favorable situation and propitious seasons are of little agricultural value. The good farmer makes every kind of soil do his will and become fertile. There is no soil, whether it be the granite soil of New England, the red clay lands of the south, the sandy soils of the coastal plains, the limestone lands of the Middle West, the deep vegetable soils of the prairie states or the black lands of the Southwest, that will not become more productive in the hands of an intelligent and industrious man.

If the kind of soil is not the paramount object of consideration in trying to make farming pay, what then is the vital consideration? It is this: knowledge of the soil and its management. We must

so know our soil and its proper management that we can make it yield better crops; that we can make, not two, but five blades of grass, or stalks of corn, or grains of wheat, grow where one grew

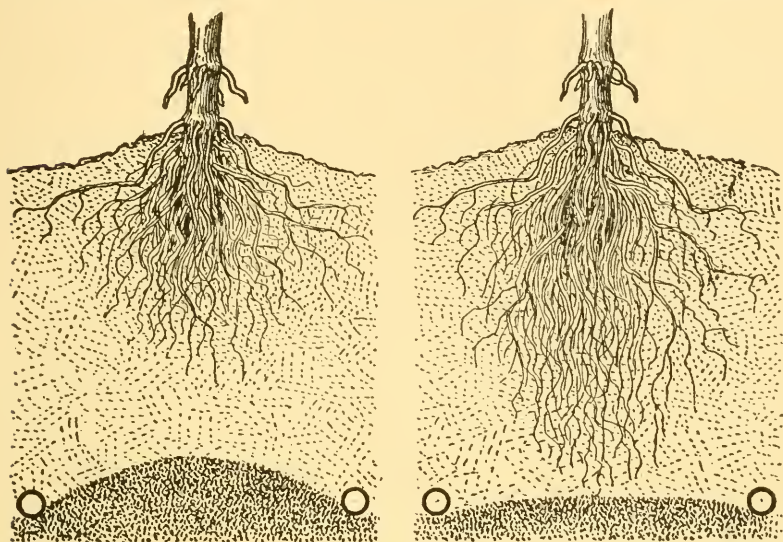

HOW GOOD DRAINAGE WORKS

When lands are drained with tiles the water level is kept far below the root bed. The roots are enabled to go down deep, their pasture ground is enlarged and they are better prepared to gather food. Well-drained lands are drier in the spring than undrained lands, and in the summer during periods of warm, dry weather, the drained lands are moister than the undrained lands.

before. These happy ends can be achieved only by the most intelligent cultivation, and by the application of every principle of improvement revealed by modern science.

HELPING NATURE

All this can be done. The old lands are not exhausted and dead, as commonly supposed. Most of them are simply sick and tired and heartbroken

through abuse, neglect and cruelty. They need a wise and tender hand to restore them to the fructuous state in which they fulfilled their mission before the soil-robber came.

The plow will do much to restore original fertility. It will assist nature to make plant food available for the tiny fibrous roots. The plow will let air and moisture into the soil. These two elements, air and moisture, will be as useful as they are above the soil where they cause iron to rust, leaves to crumble into powder, forest trees to break their original elements, bricks to chip into pieces, stones to lose their tenacity. In the same way they cause all these visible bodies to resolve themselves into original elements and go to feed plants. In that same way do they act in the soil and render this hitherto locked-up plant food available for the plant.

TILLAGE MORE NEEDED THAN FERTILIZERS

This action is readily understood if we examine an analogous case. By heat the air is driven from a can of fruit that we wish to preserve. The fruit, rich in delicate flavor and appetizing essences, keeps as long as air, with the destroying bacteria it carries, is excluded from the can. But puncture the can or remove the lid and at once the fruit begins to decay and to become fine fertilizer for a potted plant. In like manner much plant nutrition is canned up in stiff or packed soils. But let a deep plowshare go crashing into these soils and at once the "canned-up condition" gives way and the available plant food is freed as a result.

All soils, however, do not need tillage any more than all animals need corn and wheat. The wide-awake farmer must ascertain how it is with his soils. However, we do know that for the greater

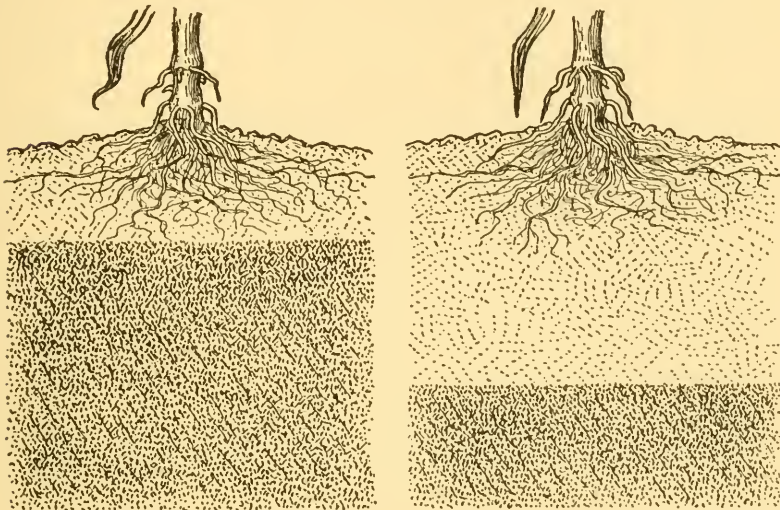

HOW BAD DRAINAGE HANDICAPS

When lands are well drained the roots are enabled to grow down deep in the soil. As a result they are dry in the spring and moist in the summer. When lands are undrained the water level is near the surface in the spring, forcing the roots to grow extremely shallow. As the summer comes on the water level is lower, far beneath the roots. As a result the plants are greatly handicapped because they are far above the water supply.

part of our older lands tillage is more needed than fertilizers. This is especially true of the hay and meadow lands, of the clay lands of the Middle states and of the red clay corn and cotton lands of the South.

DEEPEN ROOT BED GRADUALLY

Good, thorough tillage means more than merely turning a 4 or 5-inch furrow. It means the gradual

deepening of the seed and root bed until ten or a dozen inches are turned to the air for purification and rejuvenation. I say gradual, because some soils would be physically hurt by sudden deep plowing. The innovation must, in many cases, come slowly or the soil may be injured for years. When there is a probability of injury by deep plowing, let the plow down gradually. Go one, two or even three inches deeper at every plowing, until a deep and comfortable seed bed is obtained.

Chemical fertilizers will aid in soil improvement. So will some medicines aid people when they are sick. But let us not depend on either too much. They are costly in the first place, and then, again, they may do harm. Alcohol may be used as a medicine, yet may lead to disease. Commercial fertilizers add plant food to the soil and produce better crops for a time, but if depended on too much, they may do serious harm; for under the commercial fertilizer system of farming the humus in the soil is soon exhausted, and these sorts of fertilizers do nothing to restore this invaluable ingredient.

THE FUNCTION OF FERTILIZERS AND LEGUMES

Commercial fertilizers are to be used as accessories to tillage and rotation. Tillage improves the physical condition of the soil. The rational way to use commercial fertilizers is to ascertain the elements needed in the soil and then apply such fertilizers as are needed. Investigations may show that of the elements needed for plant growth, nitrogen, potassium and phosphorus, one or all may be

frequently lacking in the soil. If this be the case, maximum crop production is impossible. It follows that if one or more of these elements is lacking in the soil, the deficiency should be met, and the element or elements needed should be supplied, and it should be the business of the good farmer to find out what elements are lacking.

In this connection we should not forget the place the legumes should take in a rational system of farming. The legumes! No magician's wand could wave over any agricultural land and bless it more than do these plants. Alfalfa, the clovers—the common red clover, crimson, alsike, mammoth, white and bur—the cowpeas, the soja beans, vetches, etc.—these are nature's soil improvers and every one a cattle food of the highest excellence.

THE HIGH IMPORTANCE OF LEGUMES

These legumes add nitrogen to the soil, and since nitrogen is one of the elements found in commercial fertilizers, it is a good thing to know that it may be obtained in other ways than through costly fertilizers. The connection between the element nitrogen and the leguminous plant lies in the fact that bacteria select the clovers, alfalfa, cowpeas and other leguminous roots as the place for building their nitrogen homes.

You can see these nitrogenous homes if you will take the trouble to examine the roots of any leguminous plant. Their presence is shown by the knots or wartlike tubercles all over the roots of the plant. How do these tubercles gather nitrogen and feed plants upon it? In this way: Air, filled with atmospheric nitrogen, circulates through the soil.

As this air passes through the soil, the bacteria composing the tubercles assimilate the nitrogen and hold it as available plant food for the plant supporting their own parasitic bodies, and for crops coming after.

Great quantities of atmospheric nitrogen can thus be stored in the soil. Since nearly one-half of the

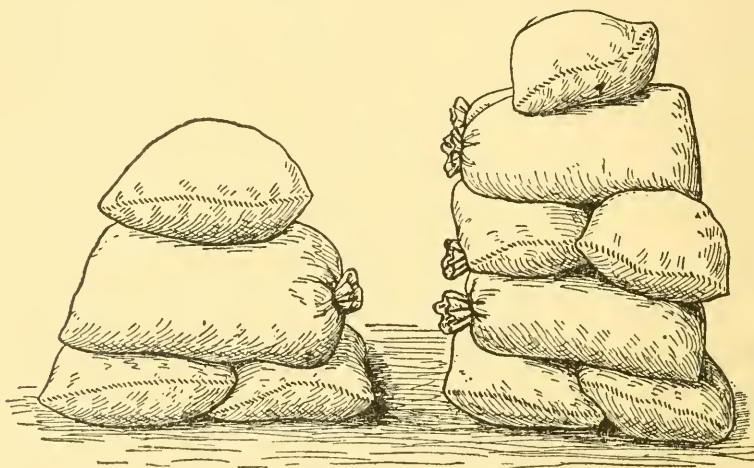

INCREASING POTATO YIELDS

When mineral fertilizers were applied, the potato crop was greatly increased. These contrasts are shown here. Acid phosphate and sulphate of potash were the carriers of these elements.

total cost of commercial fertilizers comes from nitrogen, it follows that it is rational farming to grow alfalfa, clover, cowpeas or other leguminous crops so as to diminish or entirely do away with the buying of costly nitrogen.

Potassium and phosphorus, the other two elements often deficient in the soils, must be supplied artificially, since they are minerals and cannot be drawn from the air. As yet the widest chemical or plant speculator has never dared to hope to find

a family of plants that will be able to make mineral matter for other plants.

The nearest approach to any such magical discovery is an open secret available to all. No trained genius is needed to do the work; no costly apparatus is demanded. Simply a plow and cultivator to unlock the hidden treasures and to change clay and rock and compounds into available plant food. Of course, if potassium and phosphorus are deficient in the soil they must be added artificially; but they cost little in comparison with nitrogen.

This economical and practical method of soil improvement ought to be steadily followed. The grain farmer, the cotton farmer, the hay farmer, the market gardener—in fact every business man who has to do with soil culture—can rapidly improve his land and keep it fertile by thus feeding the soil. Recently I saw a number of flower beds and forcing beds utilizing the cowpeas as a nitrogen crop for the crops that are to come on during the winter and fall months.

AN EXPERIMENT STATION OF YOUR OWN

Every soil worker should be an experimenter. This is the surest practical way to get acquainted with the soils, and thus to determine what plant food is present or absent. The following plan presents a simple method of ascertaining which of the three elements of plant food is needed in soils. It can be employed for every crop and on any farm.

Lay off five plats of equal size in any field. Plant each to the same crop and use exactly the same amount of seed to each. Prepare each plat

alike, and till with the same tools and the same number of times, and under the same conditions. To the first apply no fertilizer; to the second apply all three elements; to the third apply nitrogen only; to the fourth apply phosphorus only; to the fifth apply potassium only. The results will show whatever chemicals will pay on the land, and also what elements are needed.

STORING NITROGEN WITHOUT COST

Of the three elements most likely to be removed from the soil by continued crop production, nitrogen is the most important, because, unlike phosphorus and potassium, it is not found in appreciable quantities in the original rock. Soil is decomposed rock, therefore the decomposition and disintegration of soils are continually supplying more potash and more phosphoric acid, whereas nitrogen must be supplied from some external source. The atmosphere is composed very largely of nitrogen, and it has been finally and definitely determined that one family of plants, the leguminosæ (clover, cowpeas), are able, by the aid of certain micro-organisms in the soil, to fix the free nitrogen of the air and to make it available for the use of plants.

The consideration of nitrogen in relation to soil fertility is important also because of the properties of this element. Of all the elements of plant growth, nitrogen is the most fickle, unstable and unreliable. It continually exhibits a tendency to leave its chemical combination. For this reason it is eminently fitted for the life processes which require continued changes in the plant. But this

peculiar tendency of nitrogen makes it a very difficult element for the farmer to control. It is costly.

For a great many reasons we see that any method or practice that will increase the store of nitrogen in the soil will greatly improve its fertility. It has been determined that all leguminous plants have the peculiar power of fixing the free nitrogen gas of the air, which exists in such great abundance, and

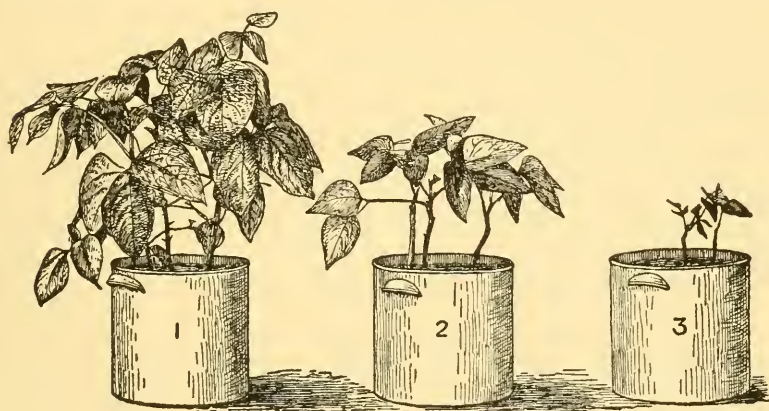

FERTILIZING THE COWPEA

- No. 1. Phosphorus and potassium, but no nitrogen.
- No. 2. Nitrogen, but no phosphorus and potassium.
- No. 3. No fertilizers applied.

changing it to the form of nitrates, in which form it can be readily used by all species of plants. This fixation is accomplished by means of a minute micro-organism in the soil, which attaches itself to the roots of these plants, causing the development of a small tubercle or swelling, and inside this tubercle or swelling the free nitrogen gas of the air is changed to nitrates. So far as we know, the leguminosæ are the only plants that are able to fix this nitrogen in quantities large enough to be of

practical importance to the cultivator of the soil. This, then, opens to us an easy way of maintaining soil fertility.

In a soil of ordinary fertility, by a proper rotation of crops in which clover or cowpeas or some other leguminous plant occurs, we are continually adding to the soil this valuable and costly element, nitrogen. Practical experience has taught us that the fertility of the soil, so far as nitrogen is concerned, may be maintained by growing a sufficient number of crops of clover or cowpeas. How, then, is the supply of phosphoric acid related to the growing of leguminous plants?

The roots of the leguminous plants grow deep in the soil. The roots of our ordinary grain crops are surface feeders, and a soil may soon become exhausted, so far as the plant food available for wheat or corn or potatoes is concerned, and may still be fertile for the growth of clover or alfalfa or cowpeas for the reason that these legumes go deeper in the soil and are able to feed upon plant food there out of the reach of many other crops. When clover or cowpeas or alfalfa is grown for fertilizing purposes, it also brings this potash and phosphoric acid from the deeper layers of the soil to the surface. Not only is soil fertility brought up from the deeper soil, but the roots of plants growing in contact with the soil are continually dissolving the elements of plant food, particularly potash and phosphoric acid, and any crop grown upon the soil for the purpose of green manuring is at the same time increasing the available plant food in the soil by dissolving the unavailable compounds.

These are some of the reasons why the growth of the leguminous plants on the soil will increase

the fertility of the land, and why the growth of leguminous plants is always a cheaper process of fertilizing than is the application of commercial fertilizers. Wherever clover and alfalfa can be successfully grown they are unquestionably the best of all leguminous plants for fertilizing purposes, but sometimes soils are too poor to grow either successfully. On such soils cowpeas will usually produce a large growth and succeed in fixing considerable quantities of nitrogen.

CHAPTER II

How Rotations Help Out

Crop rotation is not necessary for all kinds of crops or for all lines of agriculture. The truck farmer, and the florist, and even others, may prefer single crops, even though great quantities of plant food must be bought. The value of their products is such that they can afford to do this. The hay farmer often prefers a single crop system to a change of crops, but to keep his grass thrifty much top dressing is necessary. Pasture lands, too, where permanency is the rule, must often wait long years before they can find rest from change. There are exceptions, however. The majority of our people raise more than a single line of products. Diversification is the rule.

Nature suggests a rotation of crops. Cut a forest growth and a change of trees comes on. Pasture lands give way to weeds and thistles; blue grass and Bermuda drive out the clovers and timothy. Crops do best when furnished a fresh, productive and well-tilled soil. Just as animals like variety in food and new pastures, so plants want new and fresh feeding grounds. We can readily see how a soil is injured when a cultivated crop like corn or cotton is grown on it year after year. The humus is burned out, the soil hardens and deadens, the elements of plant food especially needed for these special crops become scant. The soil loses its productive power. These troubles could be corrected to a great extent by a change in the crops.

The best rotation demands, not only a change in crops, but a change in the feeding habits of the crop. For instance, plants that are shallow feeders should follow those whose roots penetrate the ground deeply. Corn, a shallow penetrator, should follow clover or alfalfa, a deep grower. As the clover roots strike deeply, the tightly bound subsoil is opened, moisture goes down, air enters, and roots decay—all contributing to the making and releasing of plant food from the compounds that hold it.

VARYING NEEDS OF PLANTS

Then, again, plants vary as to taste. Some, like potatoes, fancy potassium in abundance. Corn does best when the soil has an abundance of nitrogen, and all grain crops must have some potash and phosphorus to make well-filled heads.

Crop rotation permits each of these to find its favorite dish. Clover, for instance, gets its nitrogen from the air, and also draws up from the subsoil mineral elements, and even gets out of the way before a summer crop comes on. Suppose, then, we follow clover by corn. Nitrogen, which has been desired by the corn, has been stored away in the soil by the clover. The clover stubble and roots which are plowed under furnish vegetable matter for further feeding; the soil is made loose and mellow, and hence moisture is held in greater abundance, so the plant suffers less severely should a dry, hot summer come on. After corn can come a crop like wheat or rye or crimson clover to make a cover crop to prevent the washing of land or the leaching of valuable plant food during the winter's rain and snow.

ROTATION AND STABILITY

One crop following another also enables the farmer to better employ his labor, his tools and his teams; it checks the spread and ravages of insects and diseases. A single crop may fail or be low in

price, but of several crops one or more is likely to be in greater demand or higher in price.



MEADOW FESCUE AND
BROME GRASS

The meadow fescue is at the right and the smooth brome grass at the left. Both are excellent for pasture and hay. They are specially desirable in permanent pastures, as both are of long duration. Both are well known in the South and in the semi-arid regions. The brome grass is being used to replace the common Buffalo grass of the prairies.

And now we come to humus. So many of our soils need it. There is little hope of making them highly productive until humus is put into them again. The growing of cultivated crops like corn or cotton deteriorates the soil, not only because plant food is taken out or washed away, and the physical condition of the soil injured, but also because the vegetable matter is used up. All kinds of stubble and weeds, clover roots, stable manure and green manure are needed to supply the exhausted vegetable matter, and bring the soils back to

the productive condition that they were in before the plant food and humus were drawn out.

WHAT THE TILLER MUST DO

If, then, land is to be made rich and kept rich, the tiller must keep these things in mind: He must

plow deep. This is not true of all soils; but old, dead, hard clay lands or loams will be improved greatly in texture, in water-holding capacity, and in feeding area for roots if the plow be sent into the soil. He must cultivate shallow. The cultivator is to kill weeds, to conserve moisture, to aerate the soil. If the cultivator be run deeper than two or three inches for most crops, the roots are likely to be injured; and to injure the roots is to lessen the feeding capacity of the plants.

THE GROWING OF GRASSES

Under usual conditions the farmer should grow live stock; and to do this successfully and economically he should have either a part of his farm in permanent pasture or he should practice some system of crop rotation that will enable him to get both pasture grass and mowing. If a permanent meadow or pasture is desired, it is wise to sow different varieties of grass seeds.

Nature mixes her seeds when she does her planting, and Nature is always a trustworthy teacher. It is a good plan in sowing seeds to have in mind a pasture that will give green grass from early spring to latest fall. In those sections of the country where it grows sparingly, and where it is easily crowded out, red clover should be mixed with all grasses sowed, for it leaves in the soil a wealth of plant food for the grasses coming after it to feed on; and we know, too, that red clover grows abundantly in many parts of our country. We should study the clover plant carefully so as to mix it with the seed.

Now, there is a reason for mixing clover and grass. The true grasses, so far as science now

shows, get all their nitrogen from the soil. Hence, they more or less exhaust the soil, but the clovers are legumes, and all legumes are able, by the means of the bacteria on their roots, to use the free nitrogen of the air. Hence, without cost to the farmer, these clovers help the soil to feed their neighbors, the true grasses. For this reason some legumes should always be included in the grass seed.



BLUE GRASS

Both the Kentucky and Canadian blue grasses are pictured here—the Canadian at the left and the Kentucky at the right. Their principal use is for permanent pastures and for lawns.

Previous Preparation.—

In the sowing of grasses or clovers it is not possible for them to do well in a soil full of weeds. It is best to plant the grass in fields from which cultivated crops have been taken. Grasses follow cowpeas, wheat and oats nicely for this reason. The soil in which grass is to be seeded should be very fine, mellow and compact. One-half the failures in growing grass is due to the fact that the land has just been plowed, and consequently its particles are loose and comparatively far apart.

This want of soil firmness is the cause of failure. Let the soil be free of weeds, but compact and mellow soil acts as a blanket to keep the moisture from wasting into air, and at the same time the warm air is enabled to circulate in the soil.

If it is necessary to plow the land previous to

seeding, let it be done some months in advance. Plowed land should then be harrowed several times so as to get it soft and mellow and compact. Where the seed bed has been carefully prepared, little work will be necessary after the seeds are sowed.

SEEDING AND FEEDING

A light harrowing is sufficient to cover the broadcasted seed. This part of the work should be done as soon as the seeds are scattered, for if there be moisture in the soil the tiny seeds will soon sprout, and if the harrowing be done after germination has somewhat advanced, the tender grass plants will be injured. I have frequently gone over fields where timothy or clover has been scattered simply on top of the ground, and have seen germinating seeds so completely unprotected that as soon as the hot sun shines on them, they wither and die. Had a slight covering been given the seed, all might have been well.

It is usually advisable to use commercial fertilizers on hay and pasture lands. Chemicals can be used to good advantage, if not to the best advantage, on the meadow crops. It is too frequently the custom to use all the chemicals on corn and cotton and wheat, and let the grasses take care of themselves. Were the grass areas as well and abundantly fertilized, not only would as much forage result, but the soil would be put in an admirable condition for corn and cotton when these later come in the rotation.

Of course it is to be understood that there is no better fertilizer for grass than stable manure, but where this is not available the commercial fer-

tilizers give good results and their use should be increased.

Sowing Grass Seed.—Very light, chaffy seed, such as those of brome grass, especially the im-

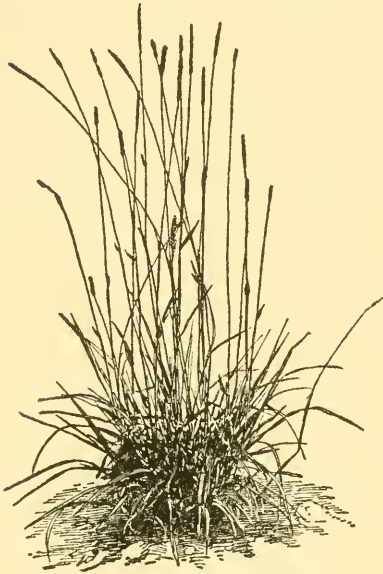

MEADOW FOXTAIL

A hardy perennial grass much like timothy in appearance. Its chief value is in mixtures for permanent pastures and meadows. It is seldom grown alone. For nutritiveness it is about at a par with timothy. It fancies rich soils and is best known in the Middle and New England states.

portant seed and awned seed, such as those of tall meadow oat grass, do not feed through seeding machines satisfactorily, and should therefore, be sown by hand. Hand sowing should always be done when the air is as still as possible. It is well-nigh impossible to distribute the seed evenly when the wind is blowing. Unless the sower is decidedly expert, it is best to sow half of the seed at a time, making the second sowing cross-wise to the first. This insures a more even stand. For such seed as will feed through it, like timothy, red-

top (re-cleaned,) clovers, and others that are small, round and clean, the wheelbarrow seeder is the most satisfactory implement yet invented. Re-cleaned blue grass seed can be sown with this implement, but the uncleaned seed should be sown by hand. Grass seeders are frequently attached to grain drills. They answer very well for

timothy to be sown with grain, but are hard to keep in order. There are several cheap grass seeding machines which scatter the seed by mechanical means. They are satisfactory for seed that feed through them readily, but it requires some patience to regulate them properly, and the sower must walk at a uniform rate or the seed will not be scattered evenly.

Seed of approximately the same size and weight may be mixed before sowing. Very large seed should never be mixed with small ones, or the small seed will feed out first. If heavy seed is mixed with light ones, even of the same size, the heavy ones will feed out first, unless the mixture is kept well stirred. In sowing such mixtures it is well to put only a small amount of seed in the machine at a time.

THE GENTLE ART OF CULTIVATION

How deep shall we cultivate? That question has been answered with quite a good deal of certainty. At least a half hundred carefully planned and executed experiments have, by their results, answered in favor of shallow cultivation. Since then we have heard much about this new idea in cultivating the soil. But we are in danger of going to the other extreme. Our fathers plowed corn; they cultivated too deep. Some of us, perhaps, cultivate too shallow; we get into trouble with weeds; and because of our thin mulch, let the water get away from the soil.

In sections where there is much rain, the shallow extreme may do; but where moisture is demanded—in the North, where the ground is frozen for so

many months; in the semi-arid regions, where the supply is generally limited—a deeper mulch and a more effective mulch is to be preferred. Four inches, perhaps, is too much and 1 inch is too little. A better depth is from 2 to 3 inches; better for weed destruction and good enough for mulch making.

Level Culture Most Important.—You will find farmers who still ridge their crops; they hill the crop that it may not be blown over by winds, nor pulled down by storms and rain. But have you ever noticed that nearby crops, although given level culture, are no more troubled by storms and wind than the hilled and ridged crops? Often not so much, is the true situation.

Hilling and ridging the crop is advisable for just one reason: to drain the land. With proper drainage and seed bed preparation, there is no occasion for either of these expensive practices.

Level culture, since it exposes a smaller area to sun and wind than ridge culture, actually protects, with greater efficiency, the water stored in the soil. Bedding the land is often advisable with some soils (although it increases the cost of planting), for the reason that it secures a small amount of drainage and a greater warmth to the soil.

When to Cultivate.—You must be in sympathy with the spirit of cultivation if you would get the best results. You must do it at the time when the soil is in the best condition to profit by the work. Just after a rain, the word goes out. But use your judgment here, else you may cultivate too early after the rain and “puddle” your land. When the next rain comes, the crust caused by the cultivation may be so hard and stiff the rain may slip away

before it can secure entrance through the stubborn top.

Here is the better plan: Just wait until the soil is slightly dried; enough so that when it is stirred it will not settle and connect with the capillary tubes below, thus defeating the very object you set about to secure. In times when you are depending upon cultivation for water preservation it will be worth your while to watch the mulch, to see if it is still an effective blanket or if the connection with the capillary tubes below is beginning to take place. If the latter be so, it is high time that you repeat the cultivating work.

Water Saving Means Early Work.—Water saving falls into two means—the catching and holding of it. You first must get water into the soil, and then you can use it; provided, of course, you do not let it escape before it is needed. Too many tillers of the soil fail to understand that the most important principle at stake in water saving is to till and cultivate in such a manner that there is free access of water into the soil. Then it can be preserved by cultivation and mulches throughout the season. But failures in supplying water, although effective culture—mulch making—is given during the growing season, are certain to happen if no water is in the soil to be conserved. If you would have water for plants for the time when they shall need it, if you would have soil water for them for later use, make no mistake about first getting it into the soil, and the rest of the work will be easy.

Points to Keep in Mind.—I. Getting ready for crops—opening soils and catching water—is of more importance than after cultivation.

2. Get water deep into the soil and you will have bigger stores of supply.

3. Cultivate after every rain, not when the soil is really wet, but before it becomes very dry.

4. Make your mulch deep enough—3 inches is none too deep in dry regions.

5. Open the soil early in the spring with a disk if you have not fall plowed or winter tilled.

6. Stir unused summer lands frequently so as to let water in and to keep it in for the next crop.

7. Lands frozen up for long periods, as in the New England territory, are as needful of water saving as those of the semi-arid or dry farming districts.

CHAPTER III

Getting the Seed Bed Right

When weather conditions are favorable for some time preceding and following wheat, grass and other fall seedlings, the seed bed loses some of its importance. But my experience is against chancing the condition at this stage of the crop. Once in four or five years, on the average, you can neglect the seed bed with impunity. But in the other years, if the soil at seeding time is improperly prepared, toll will be demanded at harvest. Especially is this true if the rainfall is slight; for, in this case, the soil is indifferently compacted and the seed lies unsprouted for days or even weeks.

To give a concrete illustration, let me use a small part of a field that was plowed and seeded a few years ago for experimental purposes. The season was dry and had been so for several weeks. But the soil responded to the plow with good satisfaction, however. Some clods were evident, but none was of large size; nor did they resist the harrow and drag to any considerable extent. Had a rain come, the seed bed would have served its purpose and started the crop. But no rain came and seed time did come.

After waiting as long as custom would permit, the field was seeded. Then days and even weeks passed, and still no rain, and no wheat either for that matter; for there was not enough water in the seed bed area to germinate the seed. The loose, opened, plowed surface had acted, not as a pump

to bring the moisture up to the seed place, but as a blanket to keep it down.

WELL-MADE SEED BEDS NOT DISAPPOINTING

Adjoining and nearby areas that had been well worked and well compacted acted in a different manner. Although of the same soil type, and subjected to the same treatment, but worked so thoroughly that the soil was made firm, compact and fine, they acted differently. The seed on these areas quickly sprouted, the young wheat plants showed the usual vitality and thrift, and at harvest time yielded 30 to 44 bushels an acre.

The field under discussion yielded but nine bushels to the acre. A part of it, however, when it was noted that the germination was so faulty and impossible, was given some additional culture through the use of a heavy roller, to serve for the purpose of packing. The roller, weighed down as much as possible, and requiring four horses to draw it, put the surface soil in a reasonably good condition; at least, enough to start the water in the subsoil reservoir upward, connecting it with the surface body in which rested the seed. Evidence of this was seen within a day or two at the top of the smooth surface, especially in the mornings, which showed the crust moist and damp.

PACKING THE SOIL STARTS WATER UPWARD

Here the proof was seen. The water was moving upward. It was passing straight up through the layer of soil in which the seed rested, and was



GOOD CROPS FOR SOIL AND STOCK

At the top we see a splendid field of soy beans. At the bottom a crop of peas and oats that yielded nine tons to the acre.

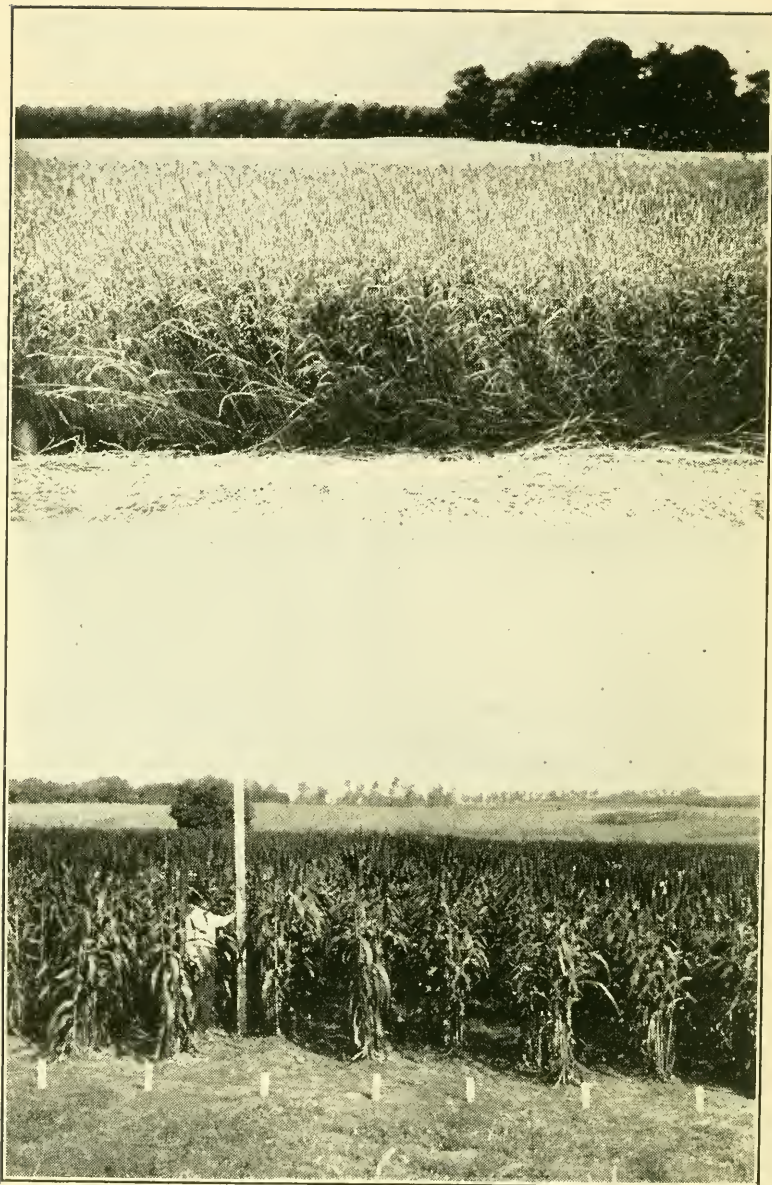

TWO VERY PROFITABLE CROPS

The timothy field at the top shows what good tillage, good feeding and good land preparation will do. At the bottom is shown a field of Kaffir corn as it grows in Kansas.

the succor needed in order that germination might take place. In a few days the sprouted grain made its appearance above ground, and, while belated and backward, overcame largely its previous misfortune and delay. At harvest this area yielded slightly more than 28 bushels an acre.

I should state here, also, that as soon as it became apparent that the soil was losing its moisture through evaporation, the fine peg-tooth harrow was dragged over the field in order to break the smooth, even crust formed by the roller and to make a mellow mulch at the top of the soil for checking the water that was escaping into the atmosphere.

This experience has always been a concrete example to me, showing the necessity of a good seed bed that must be made right, and made at the right time. This bit of experience is not out of place, for on every farm some land is being made ready for some fall crop. But is the seed bed ready?

MOISTURE AND SEED BED

For a good stand the body of the soil must be deep, compact and of otherwise right condition for germination and thrifty, active growth. Take the wheat field, for instance. If it be plowed reasonably early the chances are that with an occasional disking or harrowing the soil will be compacted and the weeds sufficiently held in check, so that at seeding time enough water will be in the soil to germinate the seed and to start the crop. If, however, plowing comes late, as it does often, a different problem is before you. You may have a crop of weeds to turn under; and these weeds may not rot fast enough to allow the turned soil to be

welded with the undersoil so that capillarity can take place by seeding time. In this case the moisture in the storehouse beneath gets into the the seed bed very slowly, thus causing a poor stand as the result.

And the same condition prevails if the soil is in a bad physical condition. When you turn under clods, coarse manure, and have an otherwise open connection between the surface or seed bed soil and the water reservoir soil, you get little or no help from the water stored beneath. The right preparation of the soil demands cautious observation of these matters in the preparation of the seed bed.

EARLY PLOWING PROTECTS WATER SUPPLY

I asked a successful farmer recently why he never had any difficulty in starting his crops. He replied that he always "secured a perfect seed bed; and the perfect seed bed I always get by early plowing and by repeated workings, using the disk, the peg-tooth harrow and the roller."

Not least among these things is early plowing. For the furrow-slice itself acts as a mulch and holds in the soil much water that would otherwise escape. Then, too, where weeds grow, water is used up; and when the winds blow over unprotected soil, water is licked up and carried away from soil and seed.

Early plowing gives weeds and grass and other debris time enough to rot and decay and to become thoroughly incorporated into the soil. By the time

the top soil and the under soil have been knitted together again capillarity is at work sending water into the seed bed—just where newly planted seed can get the advantage of it.

Then, too, early plowing and repeated workings of the soil mean mellowness and fineness and compactness. All of these do much to make the seed bed right and perfect. You want no loose, open top soil unless there is an abundance of rain to start

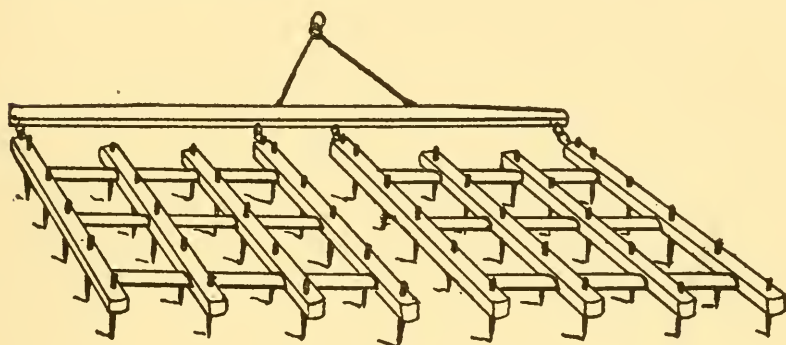

PEG-TOOTH HARROW

This common farm tool is not only useful in preparing the seed bed, but it has a place in weed destruction. After crops like corn, or cotton, or wheat are planted, the fine peg-tooth harrow can be run over the ground, not only for its effect in mellowing the soil and conserving the moisture, but in destroying the grass and weed seed at the surface of the ground.

the crop. Nor do you want a cloddy soil, nor one of poor, mechanical form, nor one in bad physical condition. Such will not be conducive to a good stand or to vigor or healthy growth. A poorly compacted, lately plowed, clod-filled soil does not make a good seed bed and handles the water with little or no satisfaction.

Even though the season be wet, repeated diskings or harrowings are good, because they keep the weeds down. If the season is dry and the soil turns

cloddy and hard, then disking, dragging and rolling are necessary in order to fine and compact and mellow the soil.

HARROW RIGHT AFTER THE PLOW

In the preparation of the soil, to harrow immediately after plowing is always advisable. A moist clod is a good deal easier to break than is a dry, hard one. The time to destroy clods is immediately after plowing, while the soil is still damp and fresh. Nor is it best to wait until morning nor to do it at night after a day's plowing has been done. For sun and air soon dry and harden; and you make a mistake by a too long delay in working soon after plowing. It is a good deal better to change from plow to harrow four or five times each day, and back again if you can do better work.

Besides, it is more satisfying to you, and certainly more restful to your team, to change from one kind of work to another rather frequently. And it is most certainly true that you can greatly lessen the work of a seed bed preparation, by a good deal of work, if you drag and harrow before the ground gets hard and dry.

WORK THE SOIL WELL

All of this intensive culture pays. First, because the plant starts better; second, because the soil is in better physical condition; and, third, because plant food has been better served for the needs of the plant.

A plant, for instance, has a good deal of trouble to get nourishment out of a hard, stony, disagree-

able clod. Its roots won't penetrate a big, hard clod. If, however, that clod during the period of seed bed making be broken up into thousands of pieces and particles, be crushed and ground into fine earth and dust, the plant food stored in it will be rendered available because the atmosphere and water and other agents that make plant food usable

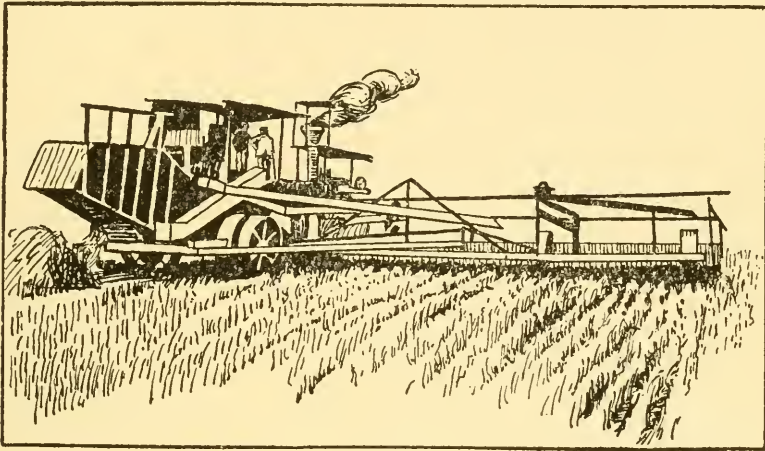

HEADER AND THRESHER

In the Far West, the combined harvester and thresher is commonly used. The implement is propelled by a traction engine. It is possible to cover a swarth 40 feet wide, and the harvesting and threshing is all done at one operation, thus bringing the expense of the work down to a minimum.

can then more actively work, and can make of the clod a palatable dish for plants.

WHEN WHEAT FOLLOWS CORN

Following corn with wheat is now being practiced more and more. And it is good practice, for it admits of crop rotation, puts in a wheat crop with no expense for plowing, and provides a better seed bed if the corn crop has been rightly cultivated than fall plowing can do. Many farmers fail to get

the best results from the use of corn ground for wheat, because they do not give this kind of land enough seed bed preparation. It may be that one disking is enough, but the chances are against it. Double disking and a cross-harrowing will do the work better and will insure the crop.

If clean cultivation has been practiced, there is a reasonably good seed bed, because the soil is compact, mellow and fine, made so by culture in the spring and by the cultivating tools during the corn-growing season. If now disked and cross-harrowed just before wheat seeding, so as to level and open the surface crust, a good covering will be given the seed, and just about as good a crop may be expected as from land plowed and prepared for wheat in the usual manner.

The difference in yield, as a rule, is not enough to cover the extra cost of plowing. Hence corn and wheat always go well together; so much so that the practice is extending and growing more popular. But if best results are to be secured, the soil must be selected with an eye for both wheat and corn and each crop must be kept in mind in the culture of the other.

CHAPTER IV

Crop Yields and Proper Culture

There are three simple and important factors which have much to do with increasing the crop yields: Increasing the crop-producing power of the soil by fertilizing the soil; planting seed of high-bred and better producing varieties; practicing proper and more thorough culture methods.

The last of these is really the simplest and most readily applied. Probably more low yields and crop failures are due to insufficient or improper cultivation than to any other single factor over which the farmer has control in the production of any particular crop. With a soil of average fertility, the preparation of the seed bed by the proper tillage and cultivation methods very largely determines the yield of the crop.

Three general methods of tillage for preparing the land are practiced: Plowing, listing and disking. There may be variations of these three methods; as, early plowing, late plowing, shallow plowing, deep plowing, single listing, double listing, little cultivation after plowing, frequent cultivation after plowing; and local conditions may determine which method is the best. That certain methods are superior to others has been proved by comparative trials carried on at the experiment stations during recent years. The largest average yield an acre with wheat in Kansas for two years, 37.43 bushels, and the largest net profit for one year, \$35.59, were secured by plowing August 15, 7

inches deep. This land was cultivated at intervals after the plowing with the harrow, acme or disk. Thus the weeds were destroyed, the soil moisture was conserved and the soil was well pulverized and

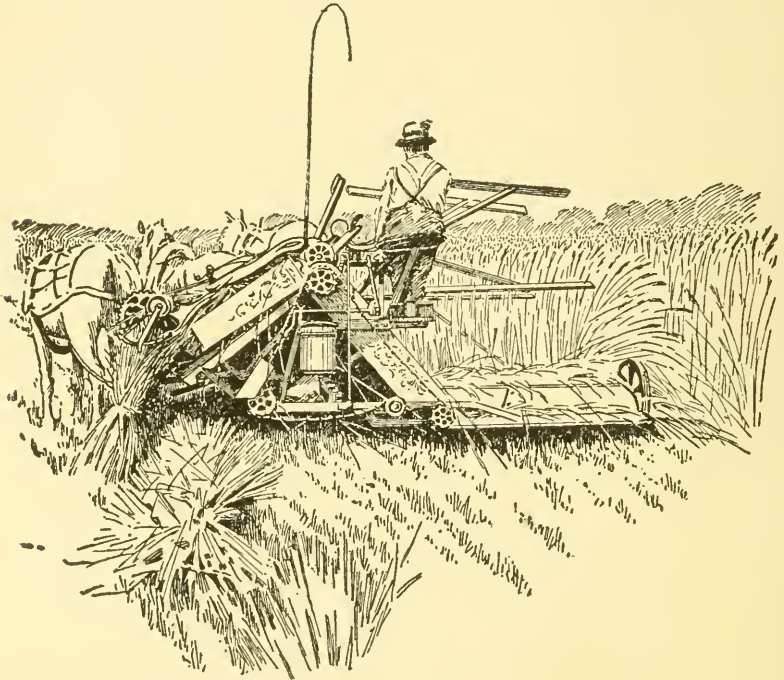

WHEAT HARVESTER

The improvements that have been made on this machine since 1833 have been remarkable. The work is now performed with little labor and is better done than in the old days with the cradle and rake. Wherever wheat is raised the wheat harvester is an indispensable tool.

well settled and put into excellent seed bed condition by the time the wheat was planted.

IDEAL SEED BED FOR SMALL SEEDS

An ideal seed bed for small seeds for best results should not be mellow or loose to too great a depth,

but rather the soil should be mellow and well pulverized only about as deep as the seed is planted. Below that depth the soil should be firm and well settled, making a good connection with the subsoil, so that the soil water stored in the subsoil may be drawn up into the surface soil. The firm soil below the seed, well connected with the subsoil, supplies moisture to the germinating seed and the young plantlet, while the mellow soil above the seed allows sufficient circulation of air to supply oxygen and favors the warming of the soil, gathering the heat of the sunshine during the day and acting as a blanket to conserve the soil heat, maintaining a more uniform temperature of the soil during the night. The mellow soil mulch above the seed conserves the soil moisture, acting as a mulch to keep the moisture from reaching the surface, where it would be rapidly lost by evaporation. The same condition favors the growth of the young shoot upward into the air and sunshine.

The too loose, deep seed bed is almost wholly dependent upon sufficient rains to germinate the seed and start the young plants. In such a seed bed drouth is very apt to injure the plants, because of the rapid drying out of the soil to the depth of the plowing. In the loose seed bed, wheat and grass for instance, is not only apt to burn out in the summer, but it is also more apt to freeze out in winter, than wheat grown in the ideal seed bed described above.

The seed bed for corn, cotton, potatoes and similar crops should be deeper and more mellow than the seed bed for small seeds, and the early cultivation of the corn and cotton land previous to planting may cause a marked increase in yield, as shown

by experiments which have been recently completed at the Kansas station. These experiments relate to different methods of tillage, which may be practiced during the winter or early spring, in preparing the seed bed and include deep and shallow plowing, double disking and listing, namely, plowing land into ridges with a double moldboard plow or lister.

In these experiments corn has usually been planted in listed furrows, except that the surface and lister methods of planting have been compared each year on the plowed plats. While the relative yields vary somewhat from year to year, it is very clear that the early plowing and early listing have given increased yields of corn, ranging from 6 to 12 bushels an acre.

CULTIVATION OF CORN, COTTON AND POTATOES

It is a safe rule to follow, and usually pays well, to prepare a good seed bed and to give the land thorough cultivation previous to planting. After planting, whether listed or surface planted, it is a good plan to harrow these crops before they come up, weather conditions permitting, and the harrowing may be continued with good results until the crops are 2 or 3 inches high. Surface-planted intertillage crops may usually be harrowed safely before they are up, or just as they come through the ground, but harrowing at this time, when the plants are very small, is apt to cover or destroy a part of them. With cotton this does not matter. Do not harrow with your eyes shut; keep your eyes open, and, if in your judgment the crop is being injured more than it is being benefited, do not harrow. The

time to clean is at the first cultivation. Most of the weeds in the row or hill which escape the first cultivation cannot be covered or destroyed at succeeding cultivations.

While it is not practicable to recommend any system of cultivation which will suit all soils and all conditions, the following plan for cultivating surface-planted crops on land which is fairly mellow and not too trashy is very satisfactory. Soon after planting go over with weeder or peg-tooth harrow. If possible, harrow a second time. Cultivate deeply the first time, throwing enough soil to the plants to cover the weeds in the row. The second cultivation should be a bit more shallow than the first, while the third and fourth cultivations should be from shallow to medium deep. If the third cultivation can follow the second cultivation closely it may be advisable, provided the weeds were well covered at the first cultivation, to throw the soil away from the row at the second cultivation and bring it back again at the third.

After the crop is laid by, if heavy rains pack and settle the soil, shallow cultivation with a single horse cultivator may often give increased yields and a clean field. Care must be taken not to cultivate too deeply so as to injure the roots; but medium rather than very shallow cultivation at the close of the season when the crop is laid by is possible. Late in the season, during the hot, dry days of July and August, the soil will dry rapidly and a deeper soil mulch is needed to conserve the soil moisture and prevent the surface soil from becoming too hot. On the other hand, if the seed bed has been well prepared, deeply loosened and well pulverized, the plants do not require deep cul-

tivation early in the spring, and the shallower cultivation at this time destroys the weeds better and allows for the more rapid and deeper warming of the soil than the too deep cultivation.

Roots gradually approach the surface near the root stock, which requires that the surface-planted crop be not cultivated too close to the hill at the last cultivation. The root crowns of listed corn,

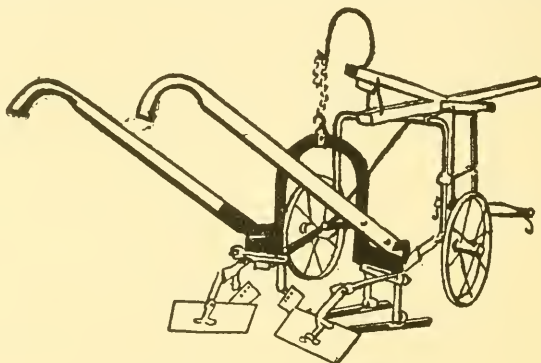

CORN CULTIVATOR

A style of cultivator that destroys the weeds and mellows the surface. The roots are not disturbed at all.

for instance, being several inches beneath the surface of the soil, allow for deep cultivation close to the hill without injury to the corn roots. The variation in yield by the different methods of cultivation from year to year and the nearly uniform average yields indicate that the method of cultivation practiced, whether 2 or 3 inches may not make much difference in the yield of the crop, provided the cultivation is done well and at the right time.

WHY WE CULTIVATE

The primary objects in cultivating are to kill the weeds and maintain a surface mulch of mellow soil

to conserve the soil moisture. The mellow surface also favors the catching and storing of the rains. The stirring in early spring warms the soil by decreasing the evaporation of water, and the mulch of mellow soil acts as a blanket to prevent the rapid radiation of heat from the soil. The soil is also aerated by cultivation, the foul gases arising from decaying organic matter are removed, and life-giving oxygen is supplied to the soil bacteria and to the growing plant roots; and more than this, the fertility of the soil is developed by cultivation.

The store or plant food in the soil is largely in an unavailable condition; before the potassium,

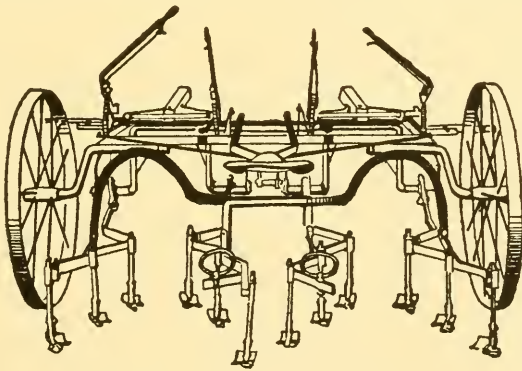

TWO-ROW CORN CULTIVATOR

With straight rows one man and three horses are enabled to do the work of two men and four horses. This is quite an item in cultivating large areas of corn.

phosphorus and nitrogen become soluble, and thus available to the plant, the soil must pass through a stage of disintegration and chemical change, which can take place only in the presence of moisture, heat and air, factors which are largely controlled by cultivation, soil and climatic conditions being similar. There are, perhaps, no exact rules or methods for

cultivating, but a farmer observing the crop and soil conditions, and understanding the principles of soil cultivation, may vary the manner and practice of cultivation somewhat to suit the conditions and accomplish the objects desired.

It is very important to cultivate at the right time. An experiment carried on for two years at the Kansas station, in cultivating corn at the right time and the wrong time, resulted as follows: Average yield for wrong time cultivation, 61.9 bushels an acre; average yield for right time cultivation, 67.8 bushels an acre, or 6.1 bushels an acre in favor of cultivating the corn at the right time. The right time means soon after the rain, when the weeds have started and the soil is just dry enough to cultivate well. The wrong time is a week or ten days later when the weeds have become larger and the soil is hard and dry and turns over in clods and lumps. It costs more to cultivate at the wrong time than at the right time, because of the slower and more difficult work and greater draft of the cultivator, due to unfavorable soil conditions, and yet the right time cultivation increases the yield.

It is important to use the best implements, but doing the work well and at the right time is even of more importance than the type of cultivator used. No one type of cultivator can be recommended as superior to others, but different kinds of cultivators are useful for different work and for different conditions. The crop grower should have more than one kind of cultivator.

CHAPTER V

What Crops for Feeding

The best system of agriculture is based upon good crops and well-bred live stock. With these to be possible the following propositions must be always kept in mind. First, the soil must be rich in the simple elements of plant food, that there may be an abundance of farm crops. Second, the farm crops must be adapted to climatic and soil environments, so as to produce from the elements in the soil the largest growth of desirable plant products or animal food. Third, superior farm stock must be raised in order to secure the cheap production of high quality meat and milk or wool and labor with the least expenditure of food.

The farmer, to make agriculture remunerative, must adapt himself to what falls within these three lines. He must enrich the soil. He must aid Nature in her efforts to change the unavailable plant food into an assimilable form. Before the plant or animal died it was unavailable for plant food. The soil always holds locked-up food in its storehouse. It is just like preserved fruit and vegetables. Our wives take tomatoes, for instance, and after preparing them, put them in the cans and seal them up to prevent decay and decomposition. In the same way our soils have been treated. We have canned them up, so to speak, by taking out organic matter, by shallow plowing, and by carelessness in tillage, until these soils are hard and baked and dead. The air no longer enters freely, and

consequently the unavailable plant food is not rendered assimilable.

If the plow is turned loose in these soils, and the land carefully and thoroughly tilled and cultivated and at the same time if organic matter is freely returned through cowpeas, clover and the stable manures, soils will quickly change from their unproductive condition into that other state which produces remunerative crops. Where the soil is poor, the crops are poor, and poor crops permit only poor live stock.



BEGGAR WEED

Best known in the South—in Florida and in the sandy lands along the gulf coast. It requires a warm soil and rather moist. It is splendid for hay and soil - renovating purposes.

of grain, forage and grass crops to obtain plants rich in feeding constituents.

But the ideal agriculture maintains itself. Every system of farming should consist of both plant production and the feeding of animals. The importance of this is seen from the following: Clover, cowpeas, alfalfa and other legumes are needed to build up the soil. And these are the very kinds of crops we want for horses, cattle, sheep and swine. We should grow such crops to improve the soil and thereby get larger yields

CATTLE FOODS THAT HELP THE LAND

Natural manures and fertilizers are needed for improving the soil. The more live stock we have, the

greater the quantity of manures produced. The commercial fertilizer bill is our greatest tax, and it is to a great extent unnecessary, for if businesslike agriculture is followed, chemicals will be needed only to a limited extent. It should be our policy to purchase fertilizers in the form of feeding stuffs. Take a dollar and purchase cottonseed meal or tankage or gluten, but instead of applying direct to the soil, as sources of nitrogen in the fertilizer, first feed them to live stock and get the value of the organized condition of the elements.

The important difference between plant food or fertilizers and animal food or plants lies in the fact that the plant takes the unorganized chemical elements and manufactures or builds them into organized tissue, which is the plant or the fruit of the plant. The plant or the fruit of the plant is fed to live stock, and meat or milk or wool or labor is produced from the organized material. The animals return to the soil the very chemical elements that the plant originally contained, only in a disorganized condition, which is the only way in which plants can use them for new growth. Thus the plant feeds the animal, the animal feeds the plant.

The animal changes raw materials into finished products. The feeder can use corn, grass, cowpeas, clover, bran and cottonseed meal and make balanced rations for all classes of live stock. These are simply raw materials, which command the lowest prices when placed on the markets of the world. An increased value follows their change into a finished product. A dairy cow, when fed a mixture of 25 pounds of corn stover, cowpea hay and cottonseed meal, with a value of but a few cents, will produce from them 2 pounds of butter

worth many cents. The increased value is the result of the change from the raw material into the finished product.

FEEDING STUFFS SHOULD BE HOME RAISED

Little need be said about the importance of growing on the farm all the bulk food required for live stock. For one thing the greater part of the feeding stuffs can be grown cheaper than they can be bought of some one else. Practically all materials grown on the farm and used for feeding purposes are low in protein but correspondingly high in other nutrients. The farmer can raise all the carbohydrates and fat needed for either the dairy or the block, but unfortunately there are no feeding stuffs made up wholly of protein. If there were, the balancing of rations in reference to cost would be a very simple process indeed.

PROTEIN NOT SOLELY PURCHASED

Though protein is the constituent most needed on most farms, when purchased, other nutrients must be taken along with the protein. Carbohydrates and fat are present in all feeding stuffs and they have a commercial value. Consequently when we buy protein we get also carbohydrates and fat. It should not be understood that these latter constituents are a trouble or a nuisance; they have a value. But you readily see it is unfortunate to purchase them when their like can be secured at home. It suggests the same idea that a necktie must always be purchased with a collar. One may

never wear a necktie, or he may have all he needs at home, yet every time he buys a collar he is obliged to pay for a necktie as well. If a necktie is not needed, but only a collar, it is likely the rule would be to get the collar having the least necktie about it and the value of the purchase would be placed wholly upon the collar and nothing on the necktie. If a farmer raises on his farm all the carbohydrates and fat he needs, and which have a low commercial value, he cannot afford to buy more of the same constituents at a price many times higher than he can raise the same himself. Yet the feeder is obliged to do this very thing when he purchases protein. It cannot be helped and it is no one's fault. There is a point of practical bearing, however, in this matter—if you have to take carbohydrates and fat along with protein and pay for them, get as little possible carbohydrates and fat in the feeding stuff and just as much protein as you can. The aim should be to

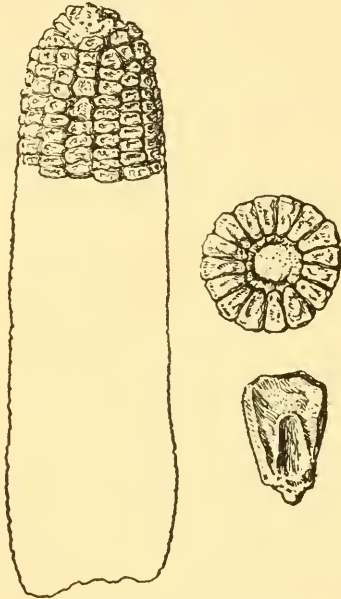

CORN KERNELS

In getting good seed corn the deep kernel is wanted. With large cobs and shallow grains the yield is always smaller than with deep grains and smaller cobs.

buy the feeding stuff having the highest quantity of digestible protein that costs the least for a pound of protein. Expressed in a few words a good rule to follow is this: To grow all of the carbohydrates and fat and not to purchase any; to grow the protein

roughages, such as clover, cowpeas and alfalfa, and little protein will need to be bought. This is economical and practical feeding. It is good farming.

USING JUDGMENT IN GETTING PROTEIN

In purchasing protein, judgment must be exercised in selecting the carrier of it. For instance, corn is slightly cheaper than bran on the basis of total digestible nutrients, but, if for the dairy, bran should be purchased rather than corn, because the bran contains nearly twice the amount of protein that corn does. Cottonseed meal contains just about five times as much digestible protein as corn, and if the two could be purchased at the same price for each pound of digestible nutrients, cottonseed meal would be many times more valuable than corn, because of the very much larger quantity of protein.

Roughage materials should be as carefully selected as the concentrates. It is often advisable to sell one kind of feeding stuff and purchase one or more kinds in exchange. It is usually economy to sell corn and oats and make an outright purchase of cottonseed meal, gluten meal and bran. Often one can sell his roughage materials to good advantage and secure others that contain more of the constituents desired, and in so doing the amount of concentrated foods can be cut down.

If the feeder uses corn stover and timothy hay, he will necessarily be forced to balance his rations with concentrated materials. On the other hand, if he uses cowpea hay, alfalfa or clover hay in main for roughage, the necessary grain material will be

small. I know markets in which timothy hay is sold for \$20 a ton and up, while cowpea hay, alfalfa and clover sell for \$20 a ton and under. You see at once that the legume hays are the most economical, for they contain three times as much digestible protein as timothy. It is to our advantage to dispose of the timothy and with the same money purchase the legume hays. The saving in corn and bran or other concentrates will be clear profit.

IN BUYING DAIRY FEEDS GET PROTEIN

Do you remember the old story about paying too much for a whistle? Ben Franklin, the Ben of Poor Richard, the Ben who did so much for liberty and justice in the early days, was responsible for it. The purpose of the story you will recall, was to point out the folly of extravagance, the folly of buying useless things, the folly of making unwise selections, the folly of choosing without considering the value or need. That tale of our school-days has not yet lost its meaning or its force, and is especially potent whenever feeding stuffs or fertilizers are to be purchased. For, after all, when we go to market for these things, we do often pay too much for the whistles we get. Every time I see a dairy farmer setting out for home with a load of corn for his cows, I think that he has bought a whistle, and has, indeed, paid too much for it. Every time fertilizers are purchased, the purchaser not having studied their contents nor the nature of his land nor the requirements of his crops, my thoughts go back to the whistle, and I think, in his case, he has likely paid too much for his whistle.

And now, when feeds are very high, with the

thousands of cattle to be fed with purchased feeds, I think of the whistle and wonder how many men are paying too much for the ones they have purchased. Although much has been said and written about the feeding of farm animals, the fact remains, nevertheless, that the purchase of their feed is still a sort of a hit or miss affair. Some buy without regard to relative merits, some select feeds because they are cheap, some use only the old standard kinds and some only those at hand and easiest to get. To me, however, any one of these methods is the purchase of a whistle for which too high a price is paid.

The few things that are already certainly known about feeds should never be allowed to get away from our minds. I allude especially to their composition, the ingredients being protein, the muscle and milk makers; fat and starch, the fat and heat makers; mineral matter, the bone maker; and water, just plain water. Water and mineral matter need not concern us, for the reason that they are either present in sufficient quantities or can be easily provided. The constituents that really concern us are protein, fat and starch. The ordinary crops of the farm contain the latter two, but with few exceptions they are deficient in protein. The farm, therefore, provides bounteously the fats and starches, and is in a sense a big heat factory in which is made the constituents for heat, fat and energy for live stock. And the farm might be made to grow the protein also, if the clovers, alfalfa and other legumes were readily taken to heart, as they should be. Negligent though we may be in regard to home-grown protein, most farmers are abundantly provided with carbohydrates and fat.

Thus one side of the feeding problem is settled. The other side, the protein side, remains unsettled, and is the real necessity for the purchase of grains and store feeds. And right here is where most men pay too much for their whistles. They get the wrong feed; they select one without due regard as to what it contains. Now, mind you, it is protein that you want. Why will you buy a food, a grain food though it be, and rich in starch, when your silo, your haymows, and your corn shocks are just fairly bulging out with this constituent already? When you do this, you simply haul home what you have already in abundance; you are buying a whistle for which you have no need.

But your real problem is to get protein, to select a feed that analyzes high in digestible protein especially, and relatively low in all other constituents; and you can do this most wisely only by comparing the several feeds on the market and judging them in reference to the protein content and the cost of each protein unit in the feed.

Corn and Cottonseed Meal.—Let me use corn as an example. You know how excellent corn is as a hog food, a horse food, a food for fattening cattle; it is superior for these purposes, because it is rich in starch and fat, and in being so makes heat, fat and energy cheaply and abundantly. As a milk producer, however, it is inferior, because it is deficient in protein, the very constituent so needed in dairy rations. Why buy it for dairy cows, therefore, if it does not possess the one constituent you need and are seeking? Is it not better to choose another feed, some kind that carries protein abundantly? I think so. Indeed, we have many foods far superior for milk cows than corn. We

have many that are superior to oats or wheat. We have cottonseed meal or gluten meal, linseed oil meal and many others. We have many foods on the market high in protein and low in starch and fat and fiber.

But for purposes of comparison let us take corn and cottonseed meal. Now just note these differences. Corn contains 7.9 pounds of digestible protein in each 100 of grain, and cottonseed meal 42.6. The first is low in protein, the second high. If you purchase in ton lots, the corn will give you 158 pounds of digestible protein to the ton and cottonseed meal 852 pounds. A vast difference, is it not? And the man who rejects the one to hold fast to the other because custom has prevailed that way, pays a big price for his whistle.

But someone says that cottonseed meal costs \$36 a ton, while corn is worth but 65 cents a bushel; is not corn the cheaper. Indeed it is not. For fattening hogs, corn is ideal; and for fattening horses and cattle it is almost indispensable; but for dairy cows that need the protein the cottonseed meal is the cheapest. Let us figure a bit. Corn at 65 cents figures about \$23.40 a ton; less, really, than the cottonseed meal. Since, however, you are after the protein, and a ton of corn contains 158 pounds of it, the cost of each pound of protein is a fraction over 14 cents. In the cottonseed meal you get 852 pounds of protein for \$36, or a pound of protein for 4.2 cents. Even if you give full credit for the fat and starch in both feed for feeding dairy cows, the preference must go to the feeding stuff carrying the most protein. But the fact is corn does not compete with other products as dairy feed as it did in former days. Corn is now so greatly

in demand for other purposes that its use in the dairy barn is being replaced by various other kinds of concentrates. I have used it here to show the importance of a study of the protein content when purchased feeding stuffs are sought. The comparisons between corn and cottonseed meal have been made for the sole purpose of suggesting what every dairyman ought to do when he needs any kind of mill feed or any other prepared feed now on the market as a concentrate for the feeding of dairy cows.

Now, mind you, your silage, corn stover, hay and other home-grown farm feeds will take care of the carbohydrate materials—the starches, the fibers, the sugars—and the fat. Your problem is to get protein, and if you desire to have your cows do their best, hence increase your profits, you will obtain the feed or feeds that gives you the protein at the cheapest cost per pound of digestible material. Otherwise you will pay dear for your whistle.

CHAPTER VI

What Forage Crops Are Best

Economy in raising live stock means the production of all roughage materials on the farm. It is possible to purchase all roughage material and yet make a financial success of growing farm animals, but it is not likely; nor is it reasonable or sensible to do so. In deciding what forage and grain crops to grow, it is well to consider the following:

- I. The crops in relation to soil and climate.
- II. The crops in relation to line of business.
- III. The home production of protein.
- IV. The growing of crops that have power of producing the greatest quantity of digestible dry matter.
- V. Soil improvement in relation to crops grown.

Crops in Relation to Soil and Climate.—Farm crops are not equally adapted to all soils and climates. Cottonseed cannot be produced in the North because of the cooler and shorter seasons. Timothy and blue grass are most productive in cool, limestone soils, and cowpeas are more at home in warm, dry soils. Nature has been generous, however, and has looked after the matter of crops and grasses quite carefully. If we but do our part there will be no difficulty in providing all roughage materials necessary for the successful production of live stock.

Our aim should be to make the best use of what we have, to improve by selection and care those

species best adapted to our soil and climate; and by better methods of cultivation, growing and caring, secure still greater yields and better returns at the cheapest cost of production.

This does not mean we shall refuse to try new plants and endeavor to adapt them to our peculiar conditions. If a new plant is found of peculiar value to our environments and business, let us endeavor to bring it to our service by all means. But let us hold on to our old friends till we have tried the new and are sure the change is no mistake.

Crops in Relation to Line of Business.—A farmer necessarily becomes a specialist. He gathers those

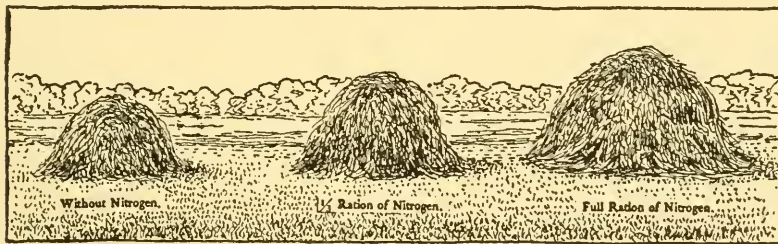

A SOIL IN NEED OF NITROGEN

This land was fertilized alike with muriate of potash and acid phosphate. The small shock on the left received no nitrogen; the shock on the right received a full ration of nitrogen and the middle shock a third of a ration of nitrogen. The increase due to this element of plant food is very marked.

classes of animals about him which he likes best and finds most profitable. He will do the same with the crops for carrying on his business. The silo, for instance, is necessary for the highest success in dairying. Succulent food must be furnished throughout the year. The silo, then, is the winter pasture field.

Soiling crops should be provided to supplement the summer pastures when they become dry and

parched. Fattening cattle need good-sized corn fields for stover and grain. The successful farmer of today and of the future will have at his hand the use of crops and methods for his special, particular purpose. The ordinary farmer will go on in the same old way and continue to say farming does not pay.

The Home Production of Protein.—The experiment station has given us positive evidence of the importance of protein for all classes of farm animals. The gist of the matter is: we have been feeding too little protein, because the ordinary farm crops are deficient in this constituent and we have found out only recently how and where it can be obtained. The discovery shows that protein costs money. To balance feeding rations properly we have been obliged to purchase large quantities of grains and concentrates to supply the needed protein.

To bring the purchased amount of protein down to the minimum quantity is one of the most important questions before the feeder today. This can be done to a very great extent by growing those crops having relatively high percentages of protein, such as cowpeas, clover, vetches, soy beans and alfalfa. There are a few others like these, but those named are the most important and two or more can be grown readily in every section of our country. Alfalfa, cowpeas and clover have already been grown in the East, South and West and long since have passed the experimental state. Following is a ration almost wholly home grown and furnishes the necessary digestible nutrients in proper quantity and proportion for a dairy cow in full flow of milk, and costs for an outside purchase less than three cents a day for each cow.

HOME GROWN RATION FOR DAIRY COW

| Feeding Stuff | DIGESTIBLE NUTRIENTS | | |
|--|----------------------|---------------|-----|
| | Protein | Carbohydrates | Fat |
| *Cowpea, Clover or Alfalfa hay, 15 lbs. ... 13.50 | 1.62 | 5.79 | .16 |
| Corn stover, 10 lbs. 5.95 | .17 | 3.24 | .07 |
| Corn silage, 30 lbs. 6.27 | .27 | 3.39 | .21 |
| Cottonseed meal, 2 lbs. ... 1.87 | .74 | .33 | .24 |
| Total.....27.59 | 2.80 | 12.75 | .68 |

* Figures of the legumes are approximate.

If timothy hay had been used in place of cowpea hay, several pounds of meal and bran would have been required to furnish the protein to balance the ration, and supply the deficiency in the roughage feeding materials. Clover and alfalfa are as nutritious from the standpoint of protein, and can be used in the same way. Every stockman should consider well the bearing this fact has upon feeding, for with it may lie success or failure. He can at least be assured that with its practice greater profit will result.

Growing Crops for the Greatest Quantity of Digestible Nutrients.—We are prone to call a crop a crop without considering its productive capacity. This is a mistake; especially when it is not a source of protein supply. It should be our policy to grow such crops as are heavy producers. When we consider the matter in this way we see that one acre often produces as many pounds of digestible nutrients as two acres of some other crop. The

following table, arranged by Dr. Jordan, gives us a vivid explanation in this respect:

| Feeding Stuff | Field per Acre Fresh Material | Dry Matter | Dry Matter per Acre | Dry Matter Digestible | Digestible Dry Matter per Acre |
|---------------|-------------------------------|------------|---------------------|-----------------------|--------------------------------|
| | Pounds | Per Ct. | Pounds | Per Ct. | Pounds |
| Alfalfa----- | 35,000 | 25.0 | 8,750 | 69 | 5,162 |
| Indian Corn-- | 30,000 | 25.0 | 7,500 | 61 | 5,025 |
| Red Clover--- | 18,000 | 30.0 | 5,400 | 57 | 3,070 |
| Oats and Peas | 20,000 | 16.2 | 3,240 | 65 | 2,106 |
| Timothy ----- | 11,500 | 38.4 | 4,416 | 57 | 2,517 |

It is readily seen from the table that alfalfa and corn produce nearly twice as much digestible nutrients as timothy, which is of considerable importance, especially when good tillable land is not readily available.

Soil Improvement in Relation to Crops Grown.—A good farmer should always be thinking of improving his soil. This is wise not only for posterity but immediate crop production as well.

Crops that may be termed soil depleters should be grown as infrequently as possible. Since the leguminous crops add nitrogen to the soil and at the same time are the best sources for protein supply, it follows that they should receive primary attention in every system of crop rotation. We want crops that will furnish the largest quantities of needed nutrients and at the same time that will improve the soil. The clovers, the cowpea and alfalfa will be more extensively grown in the future and will occupy a much more important place in every system of farming than is now accorded them.

THE WORK THE LEGUMES DO

Farming in a broad way, to be successful, must be built upon the legumes. The tiller of the soil must become a legume farmer. It matters not what line of farming you pursue, whether you grow crops as cash crops or live stock for the money income, the farming lands must be productive and more than average yields obtained if you are to go far in your enterprise. With poor crops there will be poor stock; or if the crops are sold and they be poor, the money income will be small.

From what has been said, it is evident that to grow crops successfully the lands must be fertile; they must contain much humus; they must be in proper physical condition to rid themselves of excessive water or to hold enough for seasons of drouth and there must be the elements of plant food in abundance. Of the elements of plant food those most frequently lacking are nitrogen, phosphorus and potassium. The phosphorus and potassium being minerals they must come from the soil or from fertilizers artificially applied. The same is true of nitrogen, but in this case the farmer has an advantage because he can grow his nitrogen; the legumes will store it in the soil. The free nitrogen of the air, you know, is not available plant food, yet the greater part of the air is nitrogen. No agricultural plant of itself can secure this air element—not a wee bit of it.

The secret about the legumes was revealed about 1886 when Hellriegel and Wilfarth showed the connection that bacteria have to nitrogen addition to the soil. This secret is concerned with the root tubercles that are to be found on the roots of the

legumes. The clovers, cowpeas, vetches and alfalfa are all legumes. The tubercles are little, knotted, wartlike growths on the roots of these plants, and are caused by bacteria or germs as they are sometimes called. Instead of living in nests in trees like birds, or in the ground like moles or worms, these tiny germs, so small you can't see them with a microscope, make their homes in the roots of these plants. Nestling snugly together they live, grow and multiply in their sunless homes.

Through their activity the soil is enriched by the addition of much nitrogen from the air. Just as bees gather honey from the flowers and carry it to the hives where they are prepared for it for their long future use and for the use of others, so do these root tubercles gather nitrogen in the air and fix it in their root homes where it can be used by other crops. Just as soon as the roots of leguminous plants begin to push down into the soil the bacteria or germs that make the tubercles begin to build their homes in the roots, and in so doing they add nitrogen to the soil.

You now see the importance of growing such crops as peas and clover on your land, for by their aid you can constantly add plant food to the soil. Now this much needed nitrogen is the most costly part of the fertilizers that farmers buy every year. If every farmer, then, would grow these tubercle-bearing crops he would readily add to the richness of his land, and at the same time would also escape the necessity of buying so much expensive fertilizer.

One important thing about getting nitrogen through the legumes is to have the soil in good condition. The farmer must not only be able to

induce bacteria to visit his lands and to work there in conjunction with the legumes, but he must make the new homes so comfortable and satisfactory that they will be willing to stay. You can even scatter them over your lands, but if the soil is sour and disagreeable they will die. A soil that is filled with stagnant water is not good for them, and soils that are hard, compact and dead do not attract them. And then, the same legume will not do for all crops. Clover bacteria have no liking for alfalfa or cowpea roots, nor have the cowpea bacteria any liking for the clover or alfalfa roots.

If you have been growing clover year after year and have not admitted any alfalfa bacteria you will likely fail if you attempt to grow alfalfa unless the land is inoculated with this special kind of bacteria. This means that to grow different legumes the bacteria associated with each particular legume must be secured. This calls for inoculation of the land, and even after the land has been inoculated the bacteria may not be thoroughly acclimated during the first year. When trying a legume for the first time you must give it a good chance. If it fails to meet your expectation, do not despair. Refrain from blaming the legume, and do not blame the bacteria. Just repeat the experiment on the same land; give both time to join hands, to become acquainted, to adjust their characters to suit each other's peculiarities; and be particular also to give the bacteria time to increase and to multiply and to fill the land with their kind—then the work will be done with effectiveness and to your profit and advantage.

Three ways of introducing bacteria to the soil are as follows: By introducing the soil from a

field known to contain the desired bacteria to the field where a crop is to be planted; by soaking seed in water in which soil from a field where the legume has been successfully grown has been stored; by means of pure cultures and of specific organisms suited to the legume.

If soil be used it should be taken from some field that is free of undesirable weeds. In getting the soil it is best to go down where the roots grow; somewhere between 2 and 6 inches from the surface. This can be scattered directly over a field or it may be mixed with the seed. Anywhere from 200 to 500 pounds to the acre will do. If the field be in good condition, a small quantity will leaven the entire mass. On the other hand, if the soil is bad physically, a larger quantity may be better. In any case get this material well distributed.

The pure cultures have been worked out successfully and are now available. In selecting legumes the nature of the soil should be considered. Sandy soils are not attractive to clover. Cowpeas and soy beans will grow in these sandy soils very satisfactorily. Give the sandy soils over to these crops and save the clover for the more loamy areas. So, too, if you want a permanent legume, let clover or alfalfa be selected. In inoculating the land you can always be sure that inoculation will be desirable if a small amount of humus is in the soil, if the previously grown legumes lack nodules or if the legume is used for the first time. Inoculation will help when crops grow poorly although some nodules are present. Inoculation is never needed when there is already an abundance of nodules to be found on the plants, or when the soil is already supplied abundantly with nitrogen.

CHAPTER VII

Growing Crops for Succulence

Farm stock relish succulent feeds. They give the best account of themselves when abundantly supplied with pastures or roots or green crops. This is true, not only of cattle, but of hogs, sheep, swine and poultry. Animal life has been so long adjusted to succulence and vegetable juices that to withhold these for any length of time is to invite loss along all lines of production; nor do animals thrive so well when these are withheld. When spring comes with its rejuvenating influences manifested in all directions, farm stock eagerly leave their dry foods, however rich in nutrition they may be, and revel in the green grasses along the roadside or in the pasture field. You are familiar with the result—better quality, more thrifty growth, more meat, more milk.

Taking the year all around, good pastures are not available for any great length of time; hence where well-bred farm animals are appreciated, an important problem in farm management arises as to the best method of extending the pasture season as long as possible. Succulent food may be provided by pasture, soiling crops, silage and root crops. They may be just a bit inferior to May and June grazing, but as substitutes they satisfactorily fill the bill. Good silage, after all, is but slightly inferior to green corn. Soiling crops are next best to grasses, and roots for fall and winter are not to be despised.

GOOD PASTURES ARE ALWAYS POPULAR

The testimony of dairymen is undeniably and emphatically in favor of silage, soiling crops and similar feeds to take the place of pasture, because they keep the milk yield constant. Some even claim that these feeds are in every way equal to rich pastures. Where lands are high in value and limited in quantity, the growing soiling crops often displace the pasture system. Some who follow the practice claim that the plan is even more satisfactory and far less costly. And roots, even for the dairy, but especially for all breeding stock, are indispensable. Horses without carrots, sheep without turnips; Hamlet without the ghost!

Pastures will, no doubt, long remain important in all sections where live stock are grown. Though it is true that the pasture system calls for at least twice the number of acres that are necessary where the soiling system is followed, it must be remembered that with pastures less labor is required, less attention is needed for looking after the stock, and the items of detail, incidental to soiling, do not arise. For these reasons permanent pastures are to be desired; in fact, they will be increased and made better. Where lands are exceptionally high in value, the reason for the soiling system becomes manifest at once; but where lands are cheap, there is no reason why the pasture should not be employed in the cheap production of pork or beef, or why it should not enter very largely into the production of dairy products.

I believe in permanent pastures, but I believe in good pastures. They are worthy of more attention than they have received. If they have not done

their work well, it is because their owners have given them too little attention. To merit praise they must give much grazing and constant grazing; all of which applies to the permanent pasture. The temporary pasture occurs only as a feature of short rotations, as when grain crops are raised. It is really an incident rather than a first consideration; being such, you do not expect the highest development of grass and turf, both of which are basic features of the permanent pasture.

RAPE FOR SUPPLEMENTING PASTURES

On the other hand, the poor pasture field may be supported by the use of supplementary crops, foremost among which is rape—an admirable food for sheep and swine and valuable for cattle also. Rape is a sort of cabbage, and instead of storing its nutriment in the head as the cabbage does, the rape plant distributes its nutriment throughout the leaves. It fancies most the moist, cool places and a rather fertile soil. When so favored it really gives a very large amount of food. It is sufficiently rich in nutriment to maintain all body needs, but is not quite able of itself to make large gains of growth or fat. When supplemented with grain, it becomes a very satisfactory green fodder crop.

You can sow rape any time between March and July, either broadcast or in drills 3 feet apart, using 3 or 4 pounds of seed an acre and slightly covering it. When grazed down, remove your stock and allow time enough for a second crop.

Within recent years the use of soiling crops has increased. The unsatisfactory results from pas-

tures during the late summer months, especially for dairy cows, have given popularity to the soiling system. Employed in connection with the silo, it is possible to get the effect of green



ORCHARD GRASS IN
BLOOM

crops throughout the year. Briefly, the plan means that instead of depending upon pastures, fodder is cut green and fed to cattle in the feed lot or in the stable, thus doing away with fences and extensive areas, such as are necessary with pastures. There is a saving, because no part of the forage is tramped upon nor destroyed by animals running at large over the fields. The small area given to soiling crops allows more intensive tillage, better fertilizing and more thorough cultivation.

I like the soiling system because it is extremely valuable, even where pastures are much in use. Rye, peas, oats and green corn always come in handy; and they often bridge over dry periods when pastures either are short or are dry and withered.

SOILING CROPS HAVE A PLACE

Starting with soiling crops in order of their use, we have rye as the first aid. In the South it is ready in March and in the North in April. It

should be seeded in August or September in the North and in September or October in the South. When thus planted it is ready early in the spring, long before ordinary pastures are available or before clover or wheat can be used.

Alfalfa Ranks Best.—I like alfalfa as a soiling crop; in fact, it is by all odds the best. If you have learned the secret of growing alfalfa you have a treasure indeed, so valuable as to be almost impossible of estimation. If alfalfa has not blest you as yet, then oats and peas, to be followed by cowpeas, sorghum, corn and other green crops, should be accorded places in the list. The oats and peas should go in early; cover the peas 3 or 4 inches deep, one bushel to the acre; the oats a less depth and about 2 bushels to the acre. Inasmuch as oats fancy the cool seasons rather than the warm weather, the earlier they are seeded in the spring the better. Field peas also withstand a surprisingly large amount of cold weather. Cowpeas and sorghum are warm weather crops and should go in after corn; any time, say, between May 25 and July 1.

Green Corn for Summer.—I am a great believer in corn for all farm purposes and depend upon it constantly as a soiling crop for July and August—the dry seasons—even when not particularly interested in milk. I find it is always advisable to have a couple or more acres of corn as a reserve crop for late summer feeding. Every animal on the farm relishes a few stalks of green corn at night or morning when the pastures are dry and hot.

Suppose you devote two or three acres particularly adapted to early corn planting just as early as you can. The soil may be more sandy and

hence warmer; it may be higher than the rest of the farm, hence drier. After being well tilled and fertilized, put in the corn. Plant the corn in rows $3\frac{1}{2}$ to 4 feet apart, dropping grains 3 or 4 inches apart in the rows. Give this corn the same cultivation and care as later you will give to your regular crop. In any section, by the latter part of June or early in July you will have on hand a lot of green forage to help along in case your pastures go back on you.

If you do not need this green fodder in early summer, just let it alone; it will continue its growing and will make a still heavier growth. With it at hand you need have no fear of a shrinkage in milk, because a few armfuls of this green corn as a feed, used as a supplement to the pasture or silage or other food, will complete the ration and supply your stock with just what is needed. The patch of corn, its size depending upon the number of animals you have, will carry you until the silage crop is ready, or if you do not have the silo, carry you into the fall season, when your winter plans for feeding will handle the case.

ROOT CROPS NOT TO BE LEFT OUT

The farmer pays little or no attention to roots, but they are worthy of some attention, for they stand high as succulent and supplementary feeds. You cannot value roots solely by the nutriment they contain. They aid in digestion and assimilation of dry foods and contribute to the healthfulness of all animals so fortunate as to get them. If fruits are of value, if not a necessity, to men, then

roots and grasses have a place in feeding farm animals.

Carrots.—These may be fed to horses and sheep, sugar beets and turnips to dry cattle and lambs, and dairy cattle and hogs relish them all. To withhold succulence, Nature's great provision of thrift and health, is to lessen profits. Ask the man who uses these crops; the horse breeder where carrots are known; the shepherd who knows his sheep and succeeds with them; the cattle breeder who has learned of the value of roots for health and appetite. The testimony as given is generally in favor of roots or of succulent substitutes.

Carrots are slightly harder to grow than beets, but they are the best feed. Sow the seed in rows about $2\frac{1}{2}$ feet apart. The rows should be ridged slightly, as this facilitates their culture. It is better, perhaps, to sow rather thickly, so as to insure a good stand. When the young plants are a few inches high, harrow the ground with a light harrow for weed destruction and for thinning purposes. It will require only a hasty going over to put the carrot patch in shape to destroy weeds and leave the plants 6 to 8 inches apart. A horse cultivator will complete the work. The large stock varieties are, of course, to be preferred to the fine grained—the garden kind.

Turnips are cultivated in the same way, but they come later in the season. From June to September will be range sufficient for your climate and environment. The Swede variety should be selected. Turnips may be sown broadcast, but for large yields the row method is preferred. Mangels are grown with the least difficulty, but they are not so good as carrots or turnips. Sow them in the

spring rather thickly, and then thin, farther apart than turnips. For sheep, roots are almost indispensable.

CORN THE BEST SILAGE CROP

Silage is pre-eminently adapted to dairy cows, and is frequently used for sheep and other farm animals. In planning a silo figure on removing at least $1\frac{1}{2}$ to 2 inches of the silage surface each day in order to prevent loss from spoiling. From 30 to 35 pounds of silage a day, combined with hay and grain, is considered by most dairy-men as a satisfactory ration for dairy cows.



YELLOW GLOBE MANGEL

The succulent nature of mangels makes them of use primarily for feeding to cows. They are best used in furnishing a palatable succulent food in winter to supplement the dry hays and grains, thus keeping the stock in good appetite and form.

Essentials of a Good Silo.—First, it must be made deep in order that the silage may pack down solidly. There should be a depth of at least 24 feet. Satisfactory silos, however, may be built with a depth of only 20 feet or even less. Second, the walls should be made vertical and perfectly smooth, so the silage may rest evenly on all sides. There should be as few corners as possible, since the greatest loss occurs in spoiling in corners. Third, square, wooden silos should have the cor-

ners boarded across, and the inside sheathing should run perpendicular at the bottom. Fourth, the inside walls of stone, brick or cement silos should have a final dressing of portland cement. Fifth, silos should be located where it will be most convenient to feed from.

Calculating Size of Silo.—The size of the silo to build may be determined in any particular case from the following data: A cubic foot of well-packed silage will weigh on the average between 35 and 40 pounds, and this is about the amount that should be fed daily to a dairy cow. If it is necessary to feed cows for six months, or 160 days, one cow will consume 180 cubic feet, or about $3\frac{1}{2}$ tons of silage. A herd of ten cows would consume 35 tons. However, there is always some loss by spoiling and waste, so it would be better to figure on about 40 tons.

One acre of corn should yield 10 to 15 tons of silage to the acre. The number of tons of silage that a square or rectangular silo will hold may be determined roughly by multiplying the length, width and depth of the silo in feet, and dividing by 50, the approximate number of cubic feet in a ton of silage. A round silo 15 feet in diameter and 20 feet deep will hold about 60 tons. The same silo 25 feet deep will hold 80 tons. A round silo 20 feet in diameter and 25 feet deep will hold a little more than 140 tons.

FILLING THE SILO

Nowadays the corn binder is desirable for cutting silage corn. It saves the expense of several men and makes loading and unloading more economical

and less fatiguing and irksome. One man with a low wagon and rack can in a few minutes secure his load, all that a two or three-horse team can draw. It is most convenient to take two or three rows at a time. It is necessary, therefore, that the binder be at work for some time in order that the hauling and cutting crews may not be delayed for want of corn.

The work in the silo, however, is the most important of all operations connected with silage making. Really good silage depends largely upon the faithfulness, constant tramping and the "everlastingly at it" of the man in the silo. Let him shirk, or do his work poorly, and you will get less corn in the silo and less quality in the product. Many of the criticisms directed against the silo belong, not to it, but to the man within, who was either lazy and irresponsible, or who did not know what was expected of him or how to do what was required of him.

This part of silage making is of such great importance that I have found it necessary to look carefully after it myself. If your silage has been of off quality in the past, go into the silo yourself next year and put the "pick-up" help at some other kind of work.

To thoroughly and continually pack the silage as fast as it falls into the silo and to pitch and tramp it all about the outer edges is the secret of making good silage. Look after the packing well at the outside, then the center will take care of itself. It is this thorough packing that rids the silo of air spaces around which decay later is found to have taken place.

It is more difficult to pack the square silo. Hence

the least carelessness here represents some loss in winter. In doing effective packing, keep the outer edges a little higher than the center, but keep tramping and packing all the time. This will force the air out as the filling process goes on.

PRESERVING ROOT CROPS IN PITS

Many, in their desire to have roots safely stored for winter, overdo the matter. They like to make as short a job of it as possible, and as soon as the crop can be dug, the roots are placed in a heap, covered with straw and then enough earth is put on them to prevent freezing in the severest winter weather. This is a great mistake, and many pits are lost because of this overprotection. It is very desirable to avoid storing large quantities of roots in the cellars of dwelling houses. Consequently, where no separate storage place is available, pitting outside is the best plan.

Gather the roots after they have been dug and sufficient time has elapsed to allow them to dry off. Place in oblong heaps in a high spot in the field so that good drainage is possible, cover with straw and a few inches of earth so that moderate frost and the slight freeze of early winter will not injure the roots, and dig a trench around the base of the pit so that water will not stand. Where the water rises near the surface during the wet period, it is best to place the roots on the top of the ground, as suggested above. However, if there is good drainage there is no reason why an excavation cannot be made 6 feet wide and about a foot deep, and as long as necessary. Begin by carefully stacking the roots, filling the first 2 feet of the trench. This will form

the first section; leave a space of about 6 inches then put in another section, and so on. Round up the top, fill the 6 inches of space between the heaps with straw and cover the whole with straw and 18 or more inches of soil.

This plan requires much less work in covering and is in reality a series of small pits, each distinct. The tubers keep better in this way, and as only one section at a time need be opened there is less liability to waste than if the pit were a large one containing the entire crop. In some sections of the country the covering or soil must be 2 or 3 feet deep to prevent freezing.

CHAPTER VIII

The Silo, Silage and Soiling Crops

The silo does for live stock what fruit cans and fruit jars do for men. One knows a tomato will quickly decay if not put in the fruit jar where it can be sealed so as to prevent the entrance of bacteria. The silo is a large pit that holds cut-up corn or other forage and keeps it succulent and prevents the maturity of the plant cells.

The object of the silo is to keep the forage as near the green state as possible. To this fact lies the noted value of silage. As we like during winter an apple that has been stored away in the cellar in preference to a dried one, so live stock relish, in the same degree, the corn plant if kept as nearly in the green state as possible. No matter how nutritive a feeding stuff is, if the animal does not like it, it usually is a failure as a milk or meat producer. Of course, no one claims that silage contains greater feeding value than the cured product. A silo has nothing about it to make more protein or carbohydrates or fat. But the juice is there, the flavor is there, as is also the effect of freshness and greenness.

ECONOMY IN SILAGE

There is great economy in silage in the fact that a larger part of the product is eaten. If the dry corn plant is fed, for instance, the ear and leaves are the only parts consumed. Fully half the feed-

ing value is lost. If, however, this be put in the silo, every particle is eaten. The feeding value is really doubled. The silo then assists the feeder in taking care of a larger number of animals from

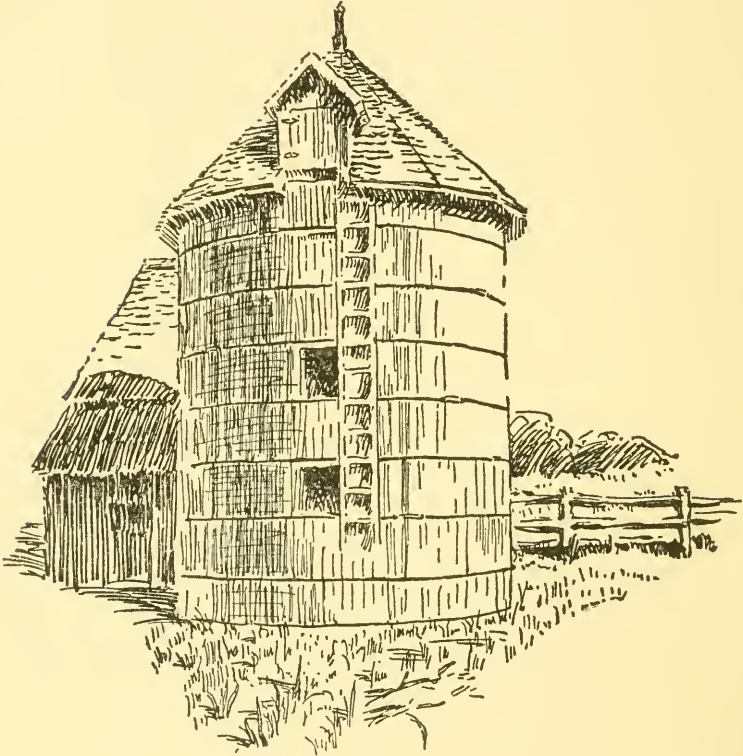

A GOOD SILO

The silo is not only a cheap means for storing food, but it keeps whatever is placed in it fresh and succulent and appetizing. Where high-grade animals are kept, the silo is desirable. Thousands of silos are added to the equipment of farms each year.

a given area than otherwise would be possible if only the dry product were fed.

Another point in economy lies in the storage of the feeding stuff. A silo is cheaply constructed

and holds an immense quantity of forage that is always at hand where feeding is to be done. Thus the labor for winter feeding is materially lessened. Wherever high-class beef animals are raised or profitable dairying is carried on, there the silo is found and its highest and best use employed.

CAPACITY OF SILOS

The following table, by King, gives the capacity of round silos at different depths and with varying inside diameters:

| FEET DEPTH | INSIDE DIAMETER IN FEET | | | |
|---------------|-------------------------|-------|-------|-------|
| | 15 | 18 | 20 | 25 |
| 20 | 58.8 | 84.7 | 104.6 | 163.4 |
| 21 | 62.9 | 90.6 | 111.8 | 174.7 |
| 22 | 67.4 | 96.8 | 119.6 | 186.8 |
| 23 | 71.7 | 103.3 | 127.5 | 199.3 |
| 24 | 76.1 | 109.6 | 135.3 | 211.5 |
| 25 | 80.6 | 116.1 | 143.3 | 223.9 |
| 26 | 85.5 | 123.0 | 151.9 | 237.4 |
| 27 | 90.2 | 129.8 | 160.3 | 250.5 |
| 28 | 95.0 | 136.8 | 168.9 | 263.9 |
| 29 | 99.9 | 143.9 | 177.6 | 277.6 |
| 30 | 105.0 | 151.1 | 186.6 | 291.6 |
| 31 | 109.8 | 158.2 | 195.6 | 305.1 |
| 32 | 115.1 | 165.7 | 204.6 | 319.6 |

FEEDING SILAGE

The quantity of silage fed depends somewhat on the kind of forage used. Silage made of clover, cowpeas or alfalfa contains more protein than one made of corn. If either of the former be used, from 15 to 20 pounds will be sufficient for a daily feed. On the other hand, if corn is used, from 25 to 50 pounds can be fed, 30 to 40 pounds being a good average. Silage can be fed once or twice each day. If a small quantity is used in the daily ration, the feeder should give silage but once; a larger quantity will require two feedings.

The feeding should be regular, that is, every day, so as to keep the top of the silo fed off to keep from spoiling. One or 2 inches from the whole of the top will prevent any decay. Feeding in the stall should be done just after milking, otherwise the odor may be observed in the milk. The grain can be fed either in connection with or just before feeding the silage.

CROPS FOR SILAGE

There are only a few crops that can be successfully used for silage. The great silo crop is corn; and so much so that whenever silo is spoken one invariably thinks of corn silage. Clover is also ensiled with a fair degree of success. Peas mixed with corn are also good, and alfalfa to some extent. Any crop having a hollow stem generally makes poor silage because of the air stored with the crop. There is also little reason for using crops that are easily cured in the field, like the grasses and hays.

DIGESTIBLE NUTRIENTS IN IMPORTANT SILAGE CROPS

| Feeding Stuff | Dry Matter in 100 pounds | DIGESTIBLE NUTRIENTS IN 100 LBS. | | |
|-------------------|-----------------------------|----------------------------------|---------------|-----|
| | | Protein | Carbohydrates | Fat |
| Corn silage ----- | 20.9 | 0.9 | 11.3 | 0.7 |
| Clover ----- | 28.0 | 2.0 | 13.5 | 1.0 |
| Alfalfa ----- | 27.5 | 3.0 | 8.5 | 1.9 |
| Cowpea ----- | 20.7 | 1.5 | 8.6 | 0.9 |
| Soja Bean ----- | 25.8 | 2.7 | 8.7 | 1.3 |

SOILING CROPS

The production of green crops to supplement summer pasture is more or less a necessity for the highest success in dairying. The milk flow cannot be maintained upon withered or dry pastures. The winter feeding of dairy cows has been made a success by the use of the silo. But ordinarily silage is used up by the end of winter and none is left for feed during the summer. Perhaps this is better after all; a change in the feed of dairy cows is as necessary as for ourselves. It is true also that with spring come good, fresh pastures, green, succulent and nutritious. Where is a better place, then, for milch cows than in such a pasture field?

Summer feeding would be simple if the pastures remained fresh and green until silage comes again. We all know that with July and August come also the hot winds and dry weather, and with them dry pastures and marked decrease in milk flow. This

can be wholly remedied by soiling crops, and at little expense to the owner. Where one has pasture for spring and early summer feeding, the soiling problem is simple indeed.

CORN THE BASIS FOR SOILING

No dairyman or feeder can get along without corn. It is the main crop for the silo or for soiling. It should be the practice to plant, as early as weather conditions permit, a small area of corn for soiling purposes. One can always select a small area that is early ready for the plow, and on this manure should be put and disked well into the soil. An application of commercial fertilizer can also be added if the soil is not as rich as it should be for the purpose. Plant the corn when the soil is thoroughly prepared and when you are reasonably sure the frosts are over.

The corn should be planted so as to produce the largest quantity of forage. For soiling purposes you are not expecting ears. A thick seeding is best. Plant in rows 36 to 40 inches apart and a grain every 3 or 4 inches. Harrow soon after planting to destroy weeds which are abundant at that time. Then cultivate frequently during the rest of the time. By the last of June you have green corn ready for stock. If your pastures are light, begin to feed a little corn every day and then gradually increase as needed.

As the corn is cut off, disk up the land and follow with cowpeas. This can be done every two or three weeks, and a crop of cowpeas for soiling or hay can be obtained the same season. A year's

experience with soiling will show the feeder the great value of this practice.

SOILING TO TAKE THE PLACE OF PASTURE

Where soiling crops are to take the place of pasture, preparation must be made the previous year. By this is meant a crop must be sown the previous fall to furnish an early crop in the spring.

Rye is better for this than any other crop. It grows all winter and shoots up early in the spring and is ready to be fed before the silage is well gone. A small acreage of rye will furnish green food for a month. By this time the clover field is ready for two or four weeks' feeding. Then you can turn in the feed lot, which should be five or six acres in size for 30 or 40 cattle. With a little of the clover hay that has just been made or some of the holdover hay of last year that was provided for this purpose, to be fed in connection with the pasture in the feed lot, you are provided with green food until the early planted corn is ready for the daily feeding.

Nothing is lost by the practice of soiling. If you have too much rye, the surplus can be cut and put in the silo and fed along during the summer; the surplus clover can be made into hay; the same can be done with cowpeas; and any excess of corn can be put in the silo.

ROTATION FOR SOILING CROPS

As soon as the rye is taken off, the rye land should be plowed and planted to corn and cowpeas; the early cut corn should be either seeded to cow-

peas or to crimson clover, and cowpea land to rye. This rotation gives soiling crops, silage crops and hay crops; a leguminous crop each year to add nitrogen to the soil; and a cultivated crop each rotation to kill out the weeds and to change unavailable plant food into available plant food. All manure made by the herd is added to the soil either in fall or winter, or in both. A practice like this brings up the soil in a very short time.

ADVANTAGES OF SOILING

Smaller Area Needed.—Where pasturing is followed, from two to five acres are required for furnishing necessary feeding stuffs for each animal a year. It is generally conceded by all who have followed soiling that three-quarters to an acre and a half will furnish the yearly food supply for a mature animal.

Fewer Fences Needed.—The only fences needed with soiling is for the feed lots. This is a saving of land where fences would be put; a saving of capital otherwise invested in fences; and a saving in labor in keeping fences clean and repaired.

No Food Destroyed by Tramping.—The tramping of cattle over pasture lands not only destroys considerable food, but it compacts the soil, especially during wet weather, and greatly damages the physical condition of the soil. As much as a third or half of the pastures are injured by tramping over them.

Less Acreage Required.—If one lives near a city where lands are more valuable, the investment in acres is a matter of considerable importance. The practice of soiling enables the dairyman to do

on half the number of acres what would be required if pasturing were followed.

Soil Improvement More Readily Obtained.—Since one needs but half the area by following soiling methods, it readily suggests a larger quantity of manure by this system. This means farming in an intensive way and insures greater productivity of land and larger crops with each successive year.

OBJECTIONS TO THE PRACTICE OF SOILING

The one objection to soiling is in the extra labor in growing and feeding the crops. By pasturing, labor is needed only in taking cattle to and from the pasture fields. The necessary extra labor is, however, a matter of small importance when considered in the light of the many advantages of the system.

Soiling Best Adapted to Dairying.—While soiling is possible for all classes of live stock, it is peculiarly a system for the dairy farmer. The food is better because of freshness and succulence; labor is always available; and the greater profits permit greater care and attention that the highest success may be attained.

CHAPTER IX

Every Farmer a Plant Breeder

Much attention has been given to the breeding of animals. As a result greater efficiency has been secured, even though scrub animals do still exist. In a general way, too, farm crops have been improved. But the rules of breeding and selection have not been as consistently indulged in with plants as with domestic animals. We have rather carelessly selected our wheat and corn—have selected our farm crops without any special search for the individuals that yield the heaviest or that give the most profitable returns.

Seed selection has come into the limelight in recent years; with some crops great progress has been made. From the crab apple has come the improved apple; by selection many classes and varieties of apples today are larger, more nutritious and more appetizing. The florist has taken some of the most common flowers and by crossing and selecting has developed improved varieties of superior usefulness and beauty. He has taken other varieties and by cross-fertilization and hybridization has established new types and new forms that differ widely from the original stock. Today these occupy places peculiar to themselves.

Seed selection is nothing more than the breeding and selecting of those forms best adapted to their environment and which, in addition, produce the most at harvest time. The propaganda for plant improvement seeks to give field crops the same

devotion that the orchard, the garden and the flower crops have had. The same principles that apply to animal breeding apply to plant breeding.

THE KEYNOTE OF PLANT BREEDING

Patience and skill are required in the breeding of plants. You must know what characters ought to be developed and what ones ought to be sup-

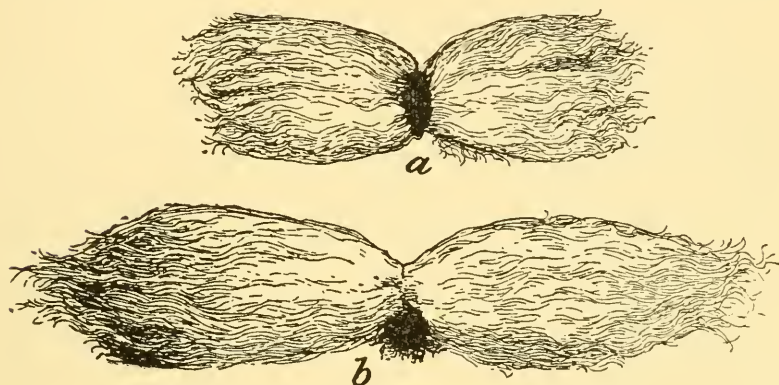

IMPROVING COTTON

The cotton fiber has been lengthened by continuous care in selection. Since the length of the fiber adds to its value, selection in this direction is vitally important and should not be neglected by any cotton grower.

pressed. The common plan of guessing is never conducive to improvement. The average yield of corn or wheat will be raised very little indeed if the crib or granary is depended upon for seed. To get the offspring of the choicest plants the parents must be observed as they grow in the fields. Suppose you go into a corn field about the time the field is ripening. You will note many superior individual plants; not only may the plant itself be superior, but the ear often will show great superiority over the common lot of the field. Your

own experience has taught you that most of the corn plants are alike. A few, however, are very good and a few are very poor. The latter should, of course, be rejected just as the scrub pig or the scrub calf is rejected. Neither will the average lot attract you; you are not seeking the average



SIX EARS TO THE STALK

When corn is bred to produce two or more large ears to the stalk, the yield will be greatly increased. The plant pictured here is reproduced just as the camera caught it.

plants. Your aim is to find the best possible in the field; those that possess vigor, vitality, strength, big broad leaves, and heavy ears. These superior plants in the corn field should be marked; and at harvest time you will know them. These are to be set apart for the next year's planting.

With wheat you should do the same. At harvest time select the heads of wheat that are largest and heaviest, and that show superiority over the average in the field. It is these heavier, stronger, more perfect ears and grains that possess quality, good blood. By using them for seed the entire crop is greatly increased.

And the same plan is open to the cotton farmer. In going over the field he finds cotton stalks well filled with bolls. On the

same soil and under the same conditions of growth and cultivation he finds cotton stalks poorly filled with small bolls. If the cotton be picked throughout the field and at the gin the seed be secured, there is no way to know from which plants the seed has come. Since more plants of the common kind were present, it is not unlikely that by getting seed at the gin a preponderance of seed from the inferior plants will prevail and no improvement will be possible at all. On the other hand, if the cotton farmer seeks the superior plants in the field, and rejects all that are average or below the average, a short time only will be necessary in order to greatly improve the crop yield. This same principle of selection applies to potatoes, oats, barley, to forage and fiber plants, and to all other plants raised for profit or pleasure. The real secret of plant improvement is cleared up when field selection of seed is begun. There is no mystery about plant breeding, nor is it something only for the scientist or the experiment station man; it is the work of all. Some of our most valuable plant creations have been the result, not of special scientific training, but of patience, devotion to an ideal, and a clear-sighted notion of what selection can do.

There is not a township or a county in any state

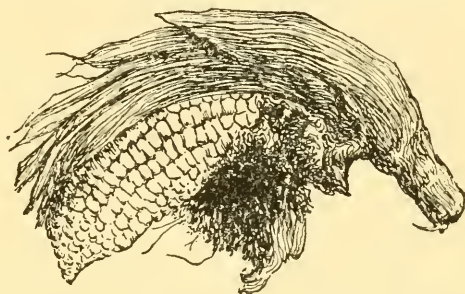

CORN SMUT

The damage to corn each year by smut is very large. Treatment of seed corn is of no value. Smutted ears should be collected and destroyed before the bursting and discharge of the spores.

or section that should not have its tens and hundreds of plant breeders, young men and old men, at work improving the plants of the garden and farm by means of selection. It not only is a most pleasant kind of work in which to engage, but it is profitable, not only through increasing the crops of the farm but because improved seed is in demand just as improved blood is always at a premium in the live stock world.

FANNING MILLS FOR GOOD SEED

Farmers lose millions a year through neglecting to properly clean and grade the seed and grain planted. This loss gets larger as land values increase. We shall never have any more land, and the value of this farm land is going up each year. So every farmer is confronted by the absolute necessity of getting more and more in the way of crops from each acre. Nothing so easy will do more in this direction than greater care in getting good seed. Even if you keep up the fertility, follow thorough tillage and cultivate assiduously, what will these avail if the seed is poor or if it contains weeds, imperfect grains or other substances not wanted in the planting?

Really, we should give back to the land the best that it gives. Hence the plump seed, heavy with vitality, only should be used, and the shriveled seed and the weed seed should be discarded. Indeed, to do otherwise is to sustain needless loss. Consider your hay crop. You sow the grass seed mixed with weeds. You get weedy hay and feed most of it, if not all of it, to your own stock. The weed seed goes through the animal and remains

in the manure. Then you spread that manure over any or every field; the result is more and more weeds, every year, everywhere.

Moreover, grass and grain seed, if selected as is ordinarily done, run down, get poorer and poorer, and in time often get quite choked with weeds. This ought to be stopped. There is no compromise. There is no excuse for a compromise. Nothing will do so much in cleaning a farm of weeds as a good fanning mill. Through its use a man can soon breed up his crops. This will yield better and be of better quality; and this kind will give him a reputation in the community for having seed or grain that is worth a good price. The fanning mill, therefore, is worth many times its cost to every farmer.

BREEDING UP THE FARM CROPS

It is a mistake to attempt the improvement of a crop in several directions at one time. The task is too big to undertake, even though you are able to devote much time to it. Limit your efforts to a few important characters, and steadfastly follow those lines. When these improvements become fixed and staple, other less important lines can be started.

It does not require much money or much labor to work in this way in crop improvement. What is expended is certain to come back shortly. Ordinarily it is to find the heavy yielding strains that we are after. Equally important is the plant's ability to withstand disease. A disease-resisting crop is more certain; the seed from such a strain is more valuable, and therefore an aim in that direc-

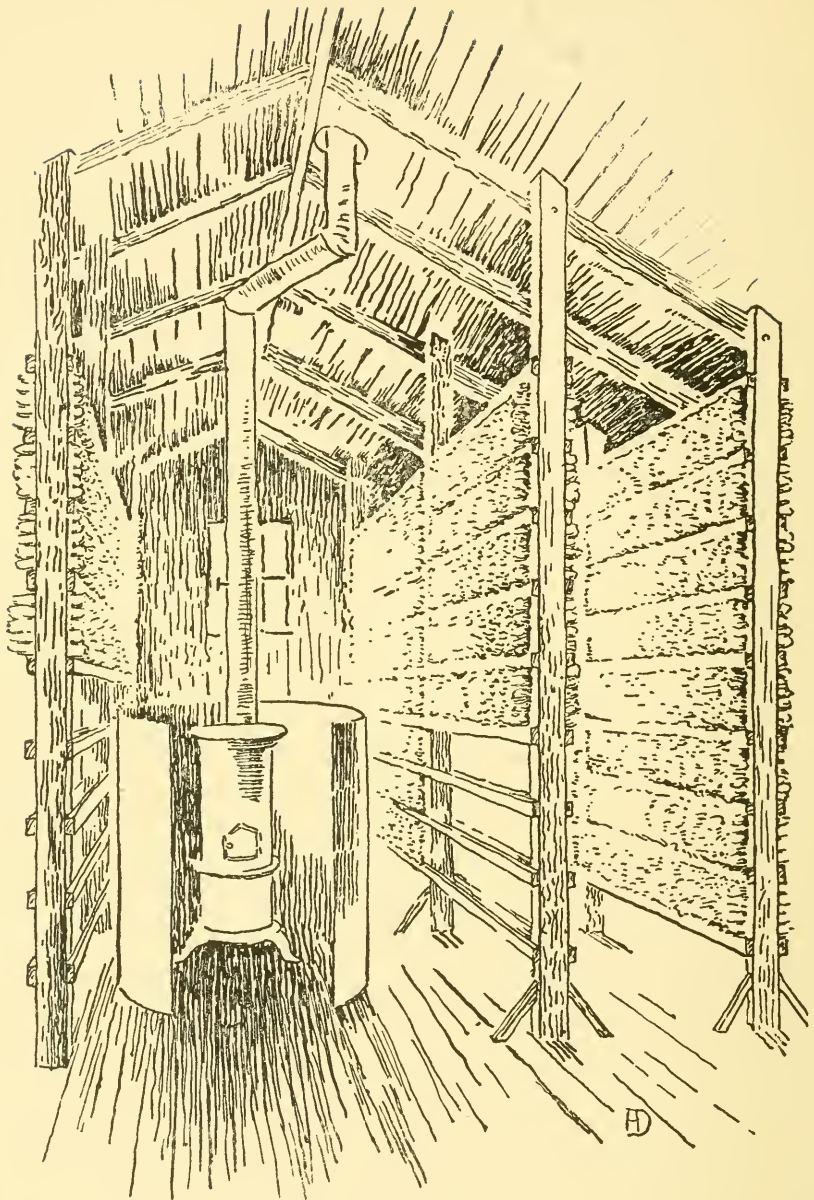

SEED CORN ROOM

The increased attention to the selection of seed corn has brought about the curing room. Where artificial heat is supplied for drying corn for seed, only a small expense is required. Any design that will provide dry, warm air will serve the purpose.

tion is worthy in any improvement. In undertaking to breed up farm crops field selection is best. To secure 100 ears of corn or bolls of cotton or heads of wheat that are the best in the field, that are disease resisting, and at the same time that are heavy yielders, is to have available for next year's

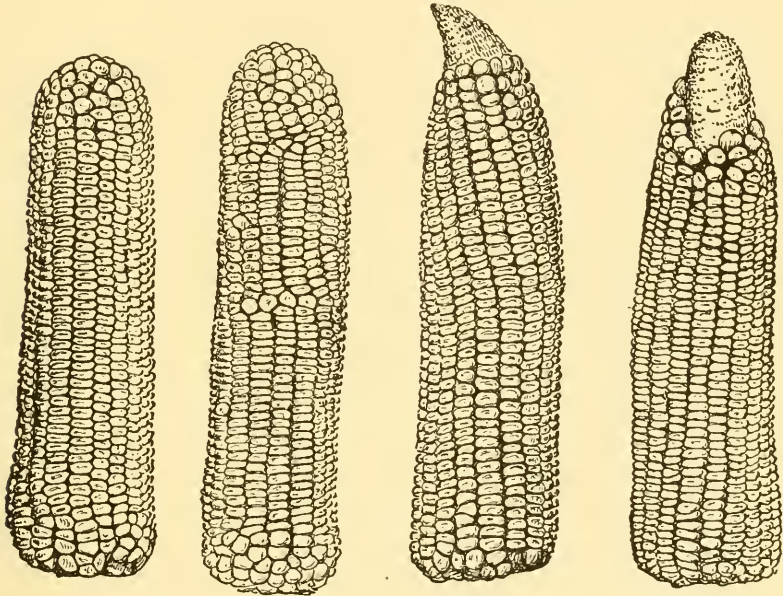

IMPROVEMENT OF CORN BY SELECTION

The variety shown here is the Boone County White. On the right are the original types from which the ears on the left were developed by selection. The yield of corn can be increased very much if right care and attention are given in the selection of the seed.

seeding some very choice seed for a seed plot. You see, in the seed plot there will be no seed used excepting what has been hand selected and consequently very choice. This seed plot should possess a type of soil common to the farm and fairly fertile; if not, it should be enriched. The same seed plot should not be used, however, year after

year. Crop rotation is as important to the seed plot as it is for the main crop.

When this seed plot crop matures, you get a chance for a study of superior plants. You will note great variations and some plants will show the same marked increase that the selected seed did in the first place over the main crop.

The seed plot offers an opportunity to trace out the superior strains. The animal breeders call this prepotency. It represents the power of the parent to transmit superior qualities to the offspring. Some animals do this to a remarkable degree; some plants do not. If individual farm plants be not studied, there is no opportunity to discover the prepotent strains. Those possessing weak transmitting power are not desirable for breeding stock and these should be discarded. Preserve seed from the plants only that are able to propagate their individual qualities and merits, otherwise your progress will be slow.

This plan of seed improvement should never be abandoned. The choicest fruit from the choicest plants should be selected each year for the next year's seed plot, and the balance, which ought to make enough seed for the main crop, should be used for that purpose. In this way, the seed plot is to be used to furnish seed for the main crop and the choice plants selected out of the seed plot are to be used as seed for the next year's seed plot. If this method of seed selection be continued long enough, there will be no running out of seed, nor will there be any deterioration in high yielding qualities. And all the time the crop will be improving because the seed is being made better. The seed plot does for farm crops what the Babcock

test and scales have been doing right along for the dairy cow. It indicates the individuals that are worth perpetuating.

LAWS OF PLANT IMPROVEMENT

The two fundamental principles behind plant improvement are heredity and variation. Upon these two you must build your structure; but you must finish it and beautify it by selection. Heredity is the law that like produces like. Variation is the law that works to produce new things. Heredity is the law of uniformity. Variation is the law of change. Heredity is satisfied with what now exists. Variation goes out to explore—to seek new paths and new fields. The plant breeder builds upon the present heredity, but he courts variation and urges it to seek new findings. If these are to his liking, he seizes them as his own, attaches them to the old heredity and builds the new structure higher and better. The work is now to fix the new acquisition and to make it a part of the building material. Variation all the while is allowed free range that it may gather in new discoveries for further improvement and use. We let heredity hold, keep and guard the values of the best fitted animals, but we call in variation to improve them.

But where is selection? If its role is so important, why is it not to be seen on this stage of improvement? It is, if nothing in the play has been struck out. Selection is man's part of the drama. It is his work to decide which of the new things that variation has found shall be held, which new ones shall be cast aside, and at what point the new acquisition is to be fixed as a part of the old

stock. In starting his operations, it is the plant breeder's duty to ascertain what stocks and individuals already have progressed furthest in the line in which he is interested, and these are the ones with which to begin. Every breeder seeks some special end. By looking over the field it is possible, if we are onto our jobs, to get individuals peculiarly adapted to the work we are lay-



EFFECT OF INBREEDING OF CORN

- No. 1. The very small stalks are inbred.
 No. 2. The large stalks are crossbred.

ing out to have performed. We ought to look for these superior individuals and, on finding them, let them be reserved for the task of improving the strain and variety.

CHAPTER X

Farm Crops

ALFALFA.—With good seed, a proper seed bed and land adapted for growing the crop, a careful farmer should be almost as sure of establishing a successful stand of alfalfa as the average farmer is of getting a stand of wheat or oats. This may seem like a strong statement, since failure to get a good stand of alfalfa has often been the experience of many farmers, especially those who were inexperienced in growing this crop. However, it is generally true that the longer alfalfa is raised on any farm, the more readily it grows and the easier it becomes for the farmer to start the crop.

Alfalfa will succeed in a variety of soils, grading from sandy to heavy clay. The crop, however, does not thrive alike on all soils; perhaps a deep, fertile loam or clayey loam well supplied with the mineral elements of plant food is the most favorable soil for growing alfalfa. The crop needs a deep, well-drained soil; on wet land, with underground water too near the surface, alfalfa will often produce poorly and the plant soon die. Alfalfa will not thrive on a soil deficient in lime, which shows an acid reaction.

It is a fact well known to old clover growers that clover cannot be readily started on old, worn lands until the soil has been improved in texture and fertility by manuring. The same is true also of alfalfa, and it is often advisable before seeding

alfalfa on thin or worn land to take a year or two in preparing the soil by green manuring, deep plowing and thorough cultivation, with the application also, when possible, of barnyard manure. Alfalfa may be started in very thin land, deficient in humus and nitrogen, but which contains a sufficient supply of the mineral elements of plant food; but under such conditions it starts very slowly, and may not produce profitable crops for a year or two after seeding; yet, in time, when the plants have established a deep root system and are well supplied with the nitrogen-gathering bacteria, the alfalfa makes a thrifty growth and produces excellent crops, even without manuring or fertilization.

How Much Seed to Sow.—The amount of alfalfa seed to sow will depend to some extent upon the quality and vitality of the seed. The general practice has been and perhaps still is, to sow about 20 pounds of seed to the acre; but many of the oldest and most successful alfalfa growers are now using much less seed. Good stands have been reported from sowing as little as 5 pounds of good seed to an acre. With alfalfa, as with clover, doubtless the season has much to do with securing a successful catch.

The Seed Bed.—A deep, loose seed bed is not a favorable one in which to seed alfalfa, clover or grasses. Such a seed bed may be in a favorable condition for planting potatoes, or perhaps corn may sprout and grow well under the conditions named, since the seed is large and strong in vitality and contains much nutriment to nourish and start the young plant. But with clover, alfalfa, grasses and other small seeds the ideal seed bed should be mellow, but finely pulverized only about as deep as the seed is planted. Beneath the point at which

the seed is placed and covered in the earth the soil should be rather firm, but not too hard or compact; such a condition as may be secured by cultivating the surface of well-settled fall plowing, or by disking and harrowing unplowed corn land in the spring.

Preparation of the Seed Bed.—The proper seed bed for fall seeding may often be prepared by summer plowing immediately after harvesting wheat or early spring grain and harrowing or disking at intervals until seeding time. It is often advisable to disk clean stubble land in preference to plowing, starting the disking as soon after harvest as possible. Millet or cowpeas cut for hay make good crops with which to precede the fall sowing of alfalfa. On foul land or in a dry climate it is well to fallow the land, practicing frequent cultivation during the summer previous to seeding in the fall. Such preparation will clear the land of weeds, store and conserve soil moisture and cause the accumulation of some available plant food for the tender young plants.

Another method of seeding, adapted to weedy land or to land which is deficient in available plant food, is to start the preparation of the seed bed early in the spring, when the land may be either plowed or cultivated with the disk-harrow. The cultivation with the common harrow, disk or Acme harrow should be continued at intervals of a week or ten days, in order to destroy the weeds, conserve the moisture and develop available plant food. Late in the spring, seed the alfalfa, choosing a time to sow, when possible, soon after a good rain, so that the soil may be in good condition to germinate the alfalfa seed. Alfalfa seeded by this method should sprout very quickly and the weeds should not be troublesome, since the weed seeds in the

surface soil will have already germinated and the weeds will have been destroyed by the early cultivation. The cultivation also causes some of the latent fertility of the soil to develop and become available, and with the abundant moisture supplied should usually insure a good start of alfalfa.

The firm condition of the soil beneath the seed and a good connection with the subsoil not only offers favorable conditions for supplying the seed with moisture, but the mellow covering over the seed allows the air and heat to reach the seed from above, and these three—moisture, heat and air—are the essential factors in seed germination; but if any of these are lacking the seed will not germinate.

Time to Sow.—Alfalfa may be successfully seeded either early in the spring or early in the fall. It may be destroyed by a hard frost just after the young plants have appeared, showing their first leaves, but when the plants have thrown out a few leaves and have made some growth they are not likely to be destroyed by frost. Thus very early seeding is perhaps more apt to be successful than medium early seeding, while late seeding is most apt to suffer from heavy rain packing the soil and from the effects of hot, dry weather. Here is a general rule which may be practiced with success: Prepare the seed bed early, either in the fall or spring, and seed when the soil is in a fit condition to germinate the seed. There is little use of sowing alfalfa unless the soil conditions are favorable to germinate the seed at once, for the seeds are much more apt to be injured and lost if they must lie for any considerable time in a seed bed which is not in fit condition to germinate seed.

By fall seeding the land usually returns a fair yield of hay the first season after sowing, whereas with spring seeding the alfalfa is not likely to make sufficient growth to produce a profitable crop of hay the first season, and should the alfalfa make sufficient growth, the weeds will usually be so abundant as to greatly reduce the value of the first season's cuttings for hay. On weedy land fall seeding has the advantage of spring seeding, in that the weeds are not troublesome in the fall and the fall-seeded alfalfa starts ahead of weeds in the spring, giving a comparatively clean growth of hay the first year after seeding.

Methods of Seeding.—A large amount of alfalfa has been seeded with the ordinary grain drill. At present the greatest objection to this method is that it requires too much seed. To sow in this way requires 20 to 30 pounds of seed an acre. The feed on the ordinary grain drill cannot be set up close enough to sow less pure seed than the amount named, and diluting with bran or other material is often unsatisfactory, causing an uneven distribution of seed. A better plan to sow with the grain drill is to have a grass-seeder attachment to the drill, which will allow close adjustment and with spouts emptying into the grain tubes, so that the seed may be dropped in the drill furrows and evenly covered. In some soils and in some seasons there is little doubt but that the method of seeding with the drill may give more favorable results than broadcasting. As a rule, however, alfalfa may be successfully started by sowing broadcast in a well-prepared seed bed, care being taken to seed at the right time and when the soil is in favorable condition for sprouting the seed. Alfalfa is success-

fully sown by hand, but in recent years the little wheelbarrow seeder, several makes of which are on the market, has come into use for broadcasting grass, clover, alfalfa and other small seeds. The seed should not be covered deeply; usually less than 1 inch is better than more than 1 inch of soil covering, while on heavy, compact soil or in wet seasons the seed should be covered very lightly. The seed bed should be fully prepared before seeding, and one brush with the harrow is usually sufficient to cover the seed in a seed bed having a mellow, even surface. If the seed is planted too deep, the young shoots will often be unable to reach the surface. The vitality of the small seed being quickly exhausted the plant and the seed are lost. There is always danger in using the drill for seeding that the seed may be planted too deep. Even if the seed is covered very lightly it must lie in a furrow, which may fill with the first beating rain, thus covering the seed or young plants and often destroying them. As a rule, it is not best to roll after seeding. In light soils or dry seasons, however, it may become desirable to roll to cover the seed and press the soil about the seed. It will always be well to follow the roller with a light harrow, leaving the ground furrowed and with a surface of mulch, and not smooth and hard as left by the roller.

Nurse Crop.—It is safest, as a rule, to sow alfalfa without a nurse crop, and this is the method usually practiced, although it is possible to get good stands in the most favorable climate, soil and season by seeding with spring grain crops. Again, in light soil, which is apt to blow, it may be advisable to sow some crop with the alfalfa in order to

protect the young plants from the drifting sand. If this method is practiced, a lighter seeding of grain should be made than when the grain is seeded alone, and in a dry season it may become desirable to cut the grain crop for hay before it matures in order to prevent the alfalfa from being destroyed by drought. The nurse-crop method cannot be considered a safe one for establishing a stand of alfalfa.

Treatment After Seeding.—Alfalfa seeded in the spring needs little care after the first season, more than to mow a few times during the summer to prevent the weeds from seeding and to keep them from “smothering” the young alfalfa plants. It is well to mow the field two or three times during the season, but the growth of weeds and alfalfa should not be cut too close to the ground until the alfalfa blooms, when it may be mowed close without injuring the plants. It seems to be true that when alfalfa has become well established, frequent close cutting seems to benefit the plant and cause it to grow more vigorously, but this is not true of the young, tender plants. It is true of alfalfa as with any other young plant, that it must form a top growth before or at the same time that it is producing roots. The leaves are the stomach and lungs of the plant, and before the roots can develop the leaves must manufacture the products which are built into the cells and tissue that constitute the roots. If this top growth of leaves is cut off before a sufficient root growth has been established to easily restore the top growth, the effect is to check the growth of the plant, weaken it, and perhaps destroy it. The fall-seeded alfalfa needs no care in the fall; the full growth of plants and weeds should be left as a winter covering. The next sea-

son the alfalfa may be regularly cut for hay, and with a good catch will often produce three or four cuttings the first year, yielding three or four tons of good hay an acre, although on foul land the hay is apt to be a little weedy.

Lime for Alfalfa.—When the soil is acid alfalfa will not succeed until the acidity has been corrected by the application of lime in some form. This acid condition in soil is apt to prevail in old, worn land. It is not usual to apply lime directly to the crop. In fact, if quicklime is scattered in alfalfa it is probable that some of the plants will be injured or destroyed by the lime. Lime in the form of carbonate of lime may be applied in small quantities directly to the crop without danger of injuring the plants. A good plan in liming soil for alfalfa is to plow the field several weeks or months before the alfalfa is to be seeded, scatter the lime soon after plowing and mix it with the surface soil by harrowing or disking, and continue the disking or harrowing at intervals until the time of seeding. On soil that would be benefited by applying lime, the application of lime before seeding will greatly improve the chances for getting a good stand and a good start of alfalfa.

ALSIKE CLOVER.—This plant, compared with common red clover, is characterized by a pinkish rather than a bluish red tinge of its blossoms. Its roots are smaller. It produces less pasture after a season of maturity and also matures later than the common red varieties. It has a perennial rather than a biennial habit of growth. It feeds somewhat near to the surface and therefore does not possess drouth-resisting qualities of the stronger varieties of clover. For bee feeding it is very popular. Its range of distribution is much more limited

than the common red variety, and is better known in the Northern states than in those of the South. It is especially adapted to clay soils, clay loams and bottom lands. It does much better on stiff clays than the mammoth variety. If moisture is present, it will do well on any soil.

The manner of sowing is similar to that of common red clover, 3 to 5 pounds of seed being used to the acre. It blends well with other kinds of grass for pasture, and with timothy, orchard grass and Kentucky blue grass it is at its best. It is frequently sown alone, but is most generally used in combination with other grasses. When sown alone it may be pastured continuously after it has made a good start in the spring. After maturity, however, it stops its growth and furnishes little pasture from that on. In dry, hot weather and on dry soils it should not be pastured as closely as would be possible in moist soils and during cooler seasons.



ALSIKE CLOVER

Also called Swedish clover. It thrives best in a cool climate. Will grow in moister soils than red clover, but is not so resistant against drouth. This plant is about half between common red clover and white clover.

ARTICHOKES.—A plant grown for the underground tubers. These are potato-like in appearance and may be white, yellow, red or purple. The white and red varieties, as a rule, give the best yields. They are used to some extent for table pur-

poses, but are most commonly grown as stock food. The tubers may be harvested or left in the ground. If the soil is not too wet they keep very well in this way. If grown for hogs, the common practice is to let the hogs do the harvesting themselves; that is, root all about and gather the tubers themselves, usually leaving enough in the soil to replant the crop another season. Very large quantities of tubers are secured, the yield varying from 300 to 1,000 bushels to the acre. They give a great deal of food, being about equal in nutritive value to potatoes and above turnips and mangels. After hogs have acquired a taste for the tubers they eat them greedily. Being heavy carriers of starch, artichokes are a good substitute for corn and not only maintain steady growth, but fatten as well.

Artichokes are not intended to be a main crop on the farm, but more as a side issue. Where hogs are raised by the lot method a small patch of artichokes is desirable. During the summer season the hogs can be pastured on clover or rye to roam in the wheat fields or other pasture fields and when fall comes on be turned into the artichoke patch where they will get a good ration for several weeks. In the following spring the artichoke patch should be disked or harrowed over and the soil put in good condition again. As the plants begin to grow, if planted in rows, cultivation should be carried on to keep the weeds down and to give the crop the value of culture. The plants growing between the rows may be cultivated out. If the planting be broadcast, then no cultivations other than the harrowings will be necessary.

In starting an artichoke patch some care should be exercised in the soil selected. They like well-

drained soils. The light sandy or gravelly soils too poor for most other crops often produce very thriving crops. A dry soil is desirable, otherwise the tubers may rot. The artichoke plant has considerable drouth-resisting qualities, and for that reason fits in very nicely with other farm crops, since the little poor patches may be given over to it to be employed as heretofore indicated. Fungous diseases and insect pests do not seem to trouble the plants. In setting the bed, give the land deep tillage and set the plants in rows 3 feet apart and the sets in rows 2 feet apart. The plantings are made by the tubers or sets, just as with potatoes. Inasmuch as the artichoke plant is not sensitive to frost it may be planted early in the spring. It is a good plan to cultivate during the summer just about the same as potatoes. The plants grow from 6 to 10 feet in height and very much resemble the wild sunflower in appearance.

BARLEY.—The principal use of barley is for malting and stock feeding. Although grown in nearly all sections of the country, its extensive culture is confined to a few states, chief among which are California, Wisconsin, Minnesota, Iowa and the Dakotas. The best malting barley is grown on rather light, well-drained soil producing medium yields of bright grain. Heavy yields of grain and straw are secured on fertile loams and clay, but the grain is darker colored and suitable only for stock feed. In fact, grain grown on heavier soils is of much higher feeding value.

Plowing and fitting the ground for barley needs to be done more deeply and thoroughly than for wheat or any other grain crop. It is good practice to follow with barley after some hoed crop that

has been well fertilized with barnyard manure. Excellent yields are secured after alfalfa or root crops. The crop matures in about 100 days for seeding, and requires a rich, warm, easily penetrated seed bed, well supplied with plant food, for it is distinctly a surface-feeding crop.

As barley is grown for two principal purposes, it requires fertilizing in accordance with the use to be made of it, since the composition is influenced by the fertilizer. For malting, a grain rich in starch is sought. Many experiments have shown that fertilizers of high potash content tend to produce a heavy grain with a large proportion of starch. For feeding purposes a high protein content is desired. Very rich soils, or those highly fertilized with barnyard manure or other nitrogenous manures, produce a heavy growth of straw and grain of good protein content. When grown for feeding, fertilizer mixtures carrying relatively large amounts of phosphoric acid and nitrogen should be used. Superphosphate, ground bone, dried blood and nitrate of soda are satisfactory sources.

Sowing.—In the Northern states the seeding time generally falls between the spring wheat and oat seedings. The young plants are more tender and sensitive to frost than wheat, and are easily injured by cold rains or drouth. On average soils sow at the rate of 2 bushels an acre. When sown on rich land or broadcasted use $2\frac{1}{2}$ bushels of seed. The best depth to seed averages 3 inches and should not be less than 2 nor more than 4.

There are two classes of barley, one with hulls and one without. The latter class is often called naked or bald barley. The hulled class consists of two-rowed, four-rowed and six-rowed types.

The two-rowed is the favorite malting type and the six-rowed is in highest esteem for stock feed. Chevalier is, perhaps, the most prominent variety of the malting types, while Manshury easily takes the lead of the stock-feed types. The hull-less barley is grown for feed. It is somewhat earlier than the hulled sorts, but usually yields much lighter. Success is a variety that has given good satisfaction at high elevations.

The prejudice against feeding barley in this country is unfounded. While not equal to corn for fattening purposes, for growing stock it stands at the head of grains. On pigs it produces flesh of the highest quality. Barley hay does not have a high feeding value and is only grown where more valuable forage crops do not thrive.

BEANS.—See Field Beans.

BEGGAR WEED.—A leguminous plant used in the Southern states for hay and soil improvement. It grows from 3 to 7 feet high and is a superior plant for sandy soils, including the hammock and pine lands of Florida and other gulf coast sections. Four or 5 pounds of clean seed are sown to the acre for soil-renovating purposes and from 8 to 10 for haying purposes. The seed should not be sown until the soil is warm, the best time being just before the summer rains. Usually two crops can be secured, the first crop being cut at the time the first flowers appear. Beggar weed yields anywhere from 2 to 5 tons an acre and the hay produced is liked as well as red clover hay. For green manuring there is perhaps no crop superior. If 3 or 4 pounds of seed are seeded in corn at the last cultivation, splendid pasturage will be secured during the rest of the season. It is not a weed and does

not become so, although the name indicates such to be the case. Wherever it has been grown it has given excellent results and cows and sheep are very fond of it.

BERMUDA GRASS.—A native of a warm climate, Bermuda grass delights in sunshine and perishes if it is withheld. When frost and cool weather approach it wraps itself in sleep until warm weather comes again, but it does not object to cattle feeding on its withered leaves and stems during its period of rest. It is hardy, and grows everywhere, covering even the poorest broken and rocky hillsides, or railroad banks, with its mantle of green. There is a well-authenticated record of $6\frac{1}{2}$ tons of Bermuda hay per acre from three mowings during one season, on Georgia bottom-land. Even the most enthusiastic believer cannot claim so much for blue grass, its rival of the cooler sections. Bermuda is commonly and easily propagated by means of underground stems, although seed may be used as well. In growing it creeps along both underground and above ground, even more rapidly than the ivy climbs on stone and brick, and thrives where land is hard, broken and stony. It is the very plant



BEGGAR WEED

With a fair stand, from 3 to 5 tons of cured hay may be secured to the acre. This hay is but slightly inferior to red clover in feeding value. The beggar weed is a most excellent crop to turn under for green manure and is considered superior for this purpose to velvet beans when using in orchards.

for the old, run-down fields of the cotton belt, and the broken hillsides that must be protected lest they wash away. In propagating, this is a good way: Plow your field as you would for corn or cotton and smooth with the harrow. Use the plow to open furrows 2 or 3 feet apart over the entire field, just as you do for corn or cotton. In these open furrows drop pieces of Bermuda roots or sods every 20 or 30 inches. When this has been done you may cover by throwing the furrow-slice back, then harrow again or roll the land.

Roots and sods may be prepared for the purpose by putting them in small piles and thoroughly chopping with an ax or spade. In this manner you will secure enough settings from a bushel of plants to plant several acres. With the coming of warm weather the Bermuda settings quickly begin to spread out in every direction, in a few months' time covering the entire surface of the land and filling the soil with a perfect mat of roots. Later in the season a disk-harrow may be run over the land with advantage, that it may cut the runners, start new settings, loosen the soil and give better foothold for the plants.

BLUE GRASS.—See Kentucky Blue Grass.

BROOM CORN.—Broom corn is of two general varieties, standard and dwarf, the difference being in height of the stalk and length of the broom. The soil preparation for planting this crop varies in no essential detail from any ordinary treatment for growing Indian corn. A finely pulverized condition of the seed bed is necessary, since a rough or sandy condition of the surface will result in covering up some of the young plants during first cultivation. It is planted in drills with an ordinary

corn planter. Special plates are made for drilling this fine seed. About 3 inches is the proper depth for planting. Cultivation may begin at practically any time after planting, by the use of the harrow lengthwise of the rows. The young plants will not be injured by this treatment, while the weeds will be kept from gaining a start. The first few weeks the young broom corn plants grow very slowly, and it is of prime importance to prevent heavy growth of weeds obtaining a foothold before the plant is big enough to cultivate. Ordinary corn cultivator machinery is used in caring for the crop.

Careful Harvesting Required.—The time for harvesting is that stage when the fibers of the broom have completed their growth and before the stalk and seed have begun to ripen. When the seed is in what is known as the dead stage, or at the end of the milk stage, it is usually the proper time for cutting. The stalks grow so high that they must be broken before it is possible to cut the brush, which is the valuable part of the crop. This is done by hand work, one man breaking the stalks down as fast as two men can cut the brush. The breaker walks backward between the two rows, bending the stalks at either hand at a height of about $2\frac{1}{2}$ or 3 feet and overlapping them in such a way as to form a continuous table of green, fibrous stalks. On this table the brushes are placed as they are cut and left until partially dry, before being hauled from the field. The proper length for cutting the brush is 6 to 8 inches below the first fibers, so as to leave a stalk of at least 6 inches in length attached to each broom. Anything longer than this will, of course, increase the tonnage and this has been, in some cases, one of

the tricks of the trade, but a marked amount of long stalks in a bale will result in a reduction of price.

The process of removing the seed from the brush is variously termed seeding, scraping or threshing, and consists of running the seed-laden heads through a cylinder similar to that of the ordinary threshing machine, except that the entire brush does not pass through, only the head being subjected to the scraping process, so as not to destroy the stalk upon which the fibers were borne.

When thoroughly dried, the brooms are baled and these bales are inclosed with rather large, smooth wire, to avoid cutting the fibers, and usually weigh about 320 pounds. A few days of rain or damp, cloudy weather at harvesting time may reduce the value of the crop very considerably. Many farmers who continue growing broom corn year after year have their own special machinery for handling it. In such cases it is customary to cut a certain amount of broom corn during the early part of the day, haul it to the house and thresh it in the afternoon and evening, so that the brooms may be gotten under shelter at the earliest possible moment. Leaving part of the cut broom corn in the field overnight, of course, exposes it to the possibility of heavy dew or rain, with its consequent bad effects. If a sufficient force of men is at hand to cut the entire crop in one or two days, and then haul in and thresh immediately, this plan is frequently pursued.

Crooked Brush Reduces Values.—Probably the greatest factor influencing the value of the crop, aside from weather conditions and curing is the number of crooked stalks. Heavy dews or wet weather during the maturing stage of the brush

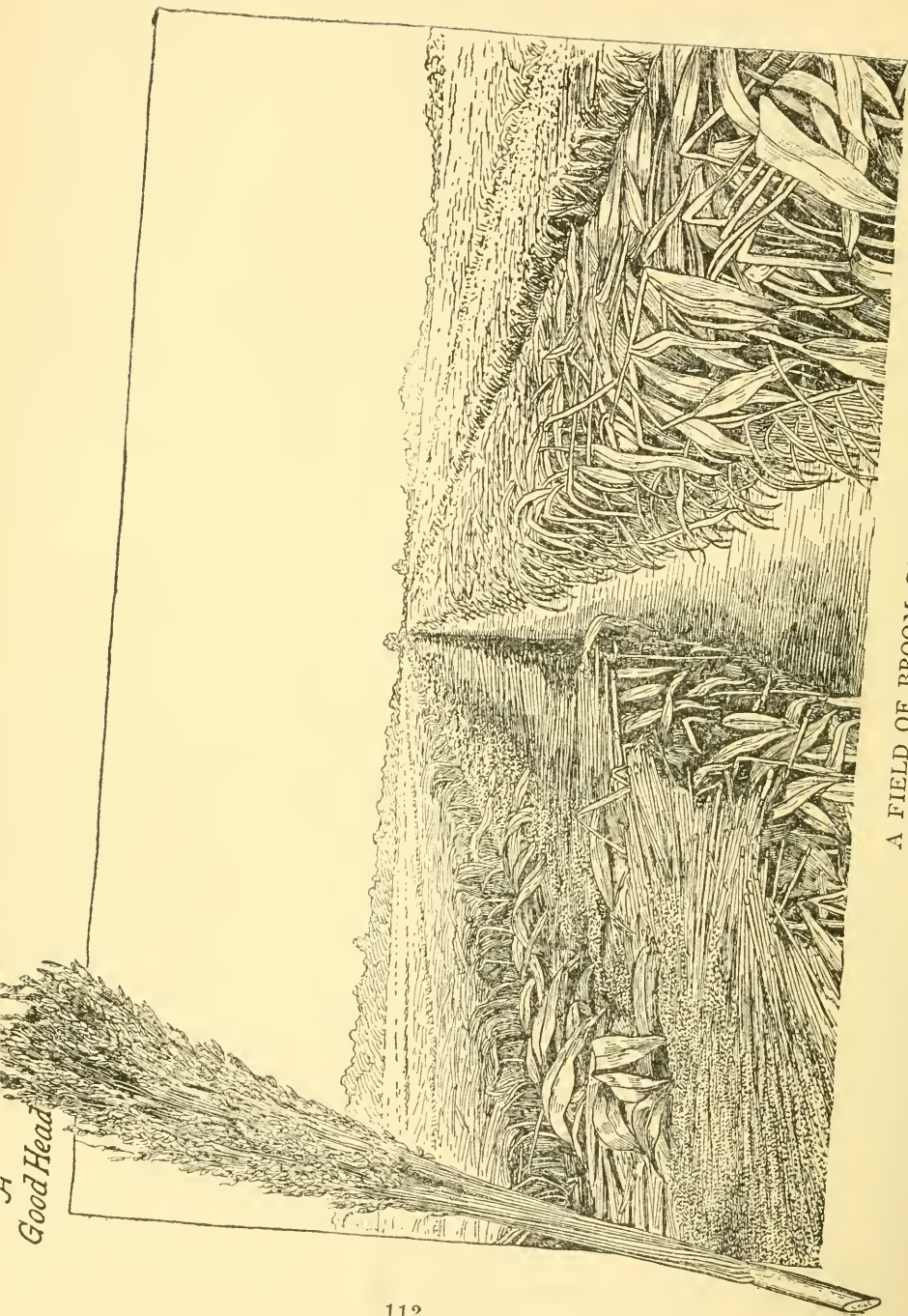

A
Good Head

A FIELD OF BROOM CORN

often result in making large numbers of stalks crooked, because of the weight of moisture held by the head. If the seed is allowed to mature to too great an extent, and thus put a heavyweight upon the stalk, this also will result in crooked stalks. The marked standard is half price for crooked stalks in separate bales. If these crooked brooms are baled with straight ones, the value of the whole will be reduced nearly one-half. The seed and chaff removed in the threshing process has little or no feeding value and is usually disposed of as waste by spreading upon the ground, or even by burning when dry.

Improvement in the quality of broom corn is brought about through seed selection. A small plat planted with seed selected with a view to vigorous growing plants and finely developed broom brushes, would probably pay on every farm where broom corn is grown. By this means the quality of the seed can be insured and less danger is experienced from the introduction of weeds and mixed varieties of broom corn than by using imported seed.

The principal difference between the standard and dwarf varieties lies in the size of the plant and length of fiber of the broom. The dwarf seems to thrive best in the dry, sandy soil of the Southwest and produces a fiber suitable for the manufacture of whisk brooms and other fine grades, while the large, standard varieties are utilized more largely for heavy brooms, for use on pavements, in barns, etc.

BROOM CORN MILLET.—See Millets.

BUCKWHEAT.—This well-known crop is used very largely as a human food. Chickens and other stock share to a limited extent and frequently the

unharvested crop is plowed under as a green manure for depleted or otherwise worn-out lands. Its value in the latter instance is due to the humus that is added to the soil. The leading buckwheat states are New York and Pennsylvania. The crop will grow on land where most other crops would starve. It shares with rye this distinction of being a poor land crop. Its best yields are obtained from fertile, well-drained and sandy loams. Wheat lands or stiff clays never attract the crop. A good yield on good ground is about 40 bushels to the acre, although the general average is only about half this amount. Frost destroys buckwheat and therefore its season of growth is much shorter than most other farm crops. However, 75 days are usually enough to bring it to maturity. It will then run from 2 to 2½ feet in height. From May to August is the usual time for seeding in the South, and from June 1 to July 10 the usual time in the North. The seed should be covered about 2 inches deep and may be drilled or scattered broadcast. It is the latter method that is most common. About a half bushel of seed is used to the acre. The general rule is that the better the land, the more the seed. The soil should be well prepared just the same as for other small grain seeds.

In fertilizing, potash, phosphoric acid and lime are the elements most in demand by the plant and they should be supplied previous to seeding. While considerable manure is helpful, it is usually preferred for other crops. The grain ripens unevenly, the blossom season extending over a period of two to four weeks in length. A good rule is to harvest just after the first seeds have ripened. To delay much after this is to lose this ripened seed. After

being cut the plant is loosely bound in sheaves and left in the field to cure. It is then threshed and without stacking. If stacked, it tends to gather moisture and in this way the seed is injured.

The three varieties best known are the Silver Hull, Japanese and the Common. At the Massachusetts station, the three varieties developed in about 74 days and yielded in the order named. The Iowa station states that the Japanese buckwheat is much superior to the other two varieties. There seems to be little difference in the value of either for making flour. The use of buckwheat as a poultry feed is becoming more popular each year, perhaps due to the success that poultrymen in France have had with the seed. The general claim seems to be that buckwheat promotes egg production early in the winter season and gives a good flavor to the meat.

BUR CLOVER.—A splendid legume for improving worn-out lands. It is grown to some extent in the South, but not nearly so much as it should be. It is an annual, having 15 to 60 branches from 15 to 30 inches in length. The flowers are yellow and the seed is borne in prickly burs with three to five seeds in a pod. To grow bur clover successfully on a soil that has never grown it before, it is generally unnecessary to resort to artificial inoculation. On such land soil inoculation will generally be complete by the beginning of the second year. If the burs are not gathered up from the soil, bacteria are abundantly supplied. This crop does its best on the heavier types of sandy soil which are underlaid by clay subsoil and which are generally moist, but it grows well on the lighter types of sandy soil as well as on soils of other character.

Where it is to be sown in the bur, the land may be prepared as for grain and grass crops. In the Southern states it is mainly broadcasted in corn and cotton and covered at the last cultivation 1 or 2 inches deep. The seed may be sown as late as the middle of September. Two bushels of seed will give a fair stand the first year, after which it is not necessary to reseed, if the crop is given proper treatment and opportunity to mature seed. After it has matured seed, other crops may follow. Orchards may be cultivated and later planted in peas in case this is desired. This procedure enriches the land and at small cost. Liberal applications of acid phosphate and potash salts should be used in connection with soil improvers like bur clover and the other legumes.

CANADA FIELD PEAS.—See Field Peas.

CARROTS.—These plants start very slowly and hence the land should be free from weeds and a fine compacted seed bed allotted them from the very beginning. The ideal soil is a deep, well-pulverized sandy loam rather abundantly supplied with potash and nitrogen. Some growers start germination before planting. To do this the seed is placed in a box in a warm room and daily moistened with warm water for several days until the germination begins. The seed is then dried in sand and sown. From 4 to 6 pounds to the acre is the usual allotment. The rows should be about $2\frac{1}{2}$ feet apart. When the plants are large enough the crop is thinned and the weeds destroyed.

Carrots are a splendid feed for horses when cereal grains like corn and oats are fed. The good secured is really more than the nutrient suggests. The succulence and juices contained in carrots pos-

sess a dietary value that should not be ignored in feeding live stock. The crop is usually harvested by hand pulling and topping. This work can be facilitated by running a plow along both sides of



CARROT

In the wild state the carrot is a bad weed, but the improved varieties are excellent for table use and they form a favorite succulent food for horses and dairy cows. The most suitable soil is a deep, mellow, rich loam, free from weed seed. Carrots are a great favorite with many horse breeders.

the row. From 200 to 400 bushels are produced to the acre. The storing is usually in pits like potatoes. On account of the large amount of hand labor required in growing the crop the acreage given each year is very limited.

CASSAVA.—There are two varieties of this plant, the bitter and the sweet. In the former hydrocyanic acid is found in the roots and is, therefore, poisonous. It is grown mostly in the tropics. The sweet variety is non-poisonous, and because of its large starch content is a splendid stock food. Cassava has as yet received no extensive use as a farm crop outside of Florida, but it has possibilities in other gulf states. It is now commercially grown for starch as well as a stock food and so satisfactory have been the tests made of it that its use should be greatly extended.

The commercial value is in the roots, or, more properly, the enlarged underground stems. These run from 1 inch to 3 inches in diameter and from 1 to 4 feet in length and contain about 20 per cent of starch and about 3 per cent of sugar. The Florida experiment station says that cassava comes nearer furnishing the Florida farmer with a universally profitable crop than any other which he can grow on equally large areas. It can be utilized in more ways, it can be sold in more different forms, it can be cheaply converted into staple and finished products and can be produced for a smaller part of its selling price than any other crop.

Land for cassava should be prepared in about the same way as that for corn. Rows 4 feet apart are plowed out and in these rows the seed or canes are dropped and covered by a turn plow or some similar implement. The canes are used for seed, being cut in sections from 4 to 6 inches in length. The first cultivation after the plants are up should be deep, and subsequent cultivations should be shallow and frequent, as for corn. After a few weeks, the plants assume a shrublike appearance,

when it is impossible to further cultivate. If a row of cowpeas be planted between the rows, the fertility of the cassava land can be maintained.

When the plants are mature, the tops are cut off 5 or 6 inches from the ground with a corn knife or hoe and the roots then pulled out. In sandy soils this can be done easily by hand, but in the stiffer, tighter soils they may need first to be loosened by means of a shovel. It is the usual custom to leave the roots in the soil until used. If drawn out and stored, their value is lessened. From 5 to 8 tons are produced to the acre. In feeding experiments, conducted at the Florida station, cassava has proven the superior of corn, chufas or peanuts for fattening pigs, a pound of pork being produced with cassava at a cost of about one cent, or at a price about one-third that of other food stuffs. Starch is the conspicuous constituent in cassava. It is evident that best results are secured when some nitrogenous food like clover or peas is fed in connection with the cassava to more evenly balance the ration.

CHUFA.—This plant is used slightly as a field crop in the South and is in especially good favor as a food for hogs. The parts that are valuable are the underground tubers, which are known as nuts. They are usually eaten raw, the hogs doing the harvesting. Sometimes they are baked. The tubers are oblong, one-fourth to one inch in length, and hard. For feeding purposes the crop ranks close to corn and is considered superior to soy beans or cowpeas. The yield is large, varying from 100 to 200 bushels an acre. The crop is propagated by means of the tubers. These are usually planted singly 2 inches deep, 10 to 15 inches apart in rows,

the rows themselves being placed 2 to 3 feet apart. The crop is planted in the spring about the same time as corn and is harvested in the fall. If the tubers are left in the ground and not harvested they will grow the following spring.

CLUB WHEAT.—Wheat with a square head and very short and compact. It is a variety popular in the Western states, where the grain remains in the field until quite ripe. It does not tend to shatter like common wheat and the stiffness of the straw makes it less liable to lodge. It is admirably adapted to regions where the combined header and thresher are used. Both bearded and bald and spring and winter varieties are grown. The chief advantage of growing this wheat lies in the fact that harvesting may be done long after ripening without any loss from shattering.

COMMON RED CLOVER.—See Red Clover.

COMMON MILLET.—See Millet.

CRIMSON CLOVER.—An annual sown in the late summer or early fall, reaching maturity in the springtime of the following year. It is quite upright in its habit of growth; more so than the other clovers and has a less proportion of leaf growth to the stems. It grows from 12 to 30 inches high and reaches maturity in time for spring crops like corn and vegetables. The blossom is crimson or scarlet, from which quality it gets its name. Its distribution is more limited than the common red variety and is most commonly grown in the Southern states. Sandy soils are most fancied by it. It has been grown all along the Atlantic shore, but in the cold, clay lands it does not do well, preferring when brought into the more northern climes sandy loams that are open and relatively warm.

In the rotation system crimson clover should be grown as a catch crop. It can succeed a crop harvested one season and be away in time for another crop the following spring. It can succeed cowpeas or wheat or potatoes and is a splendid crop to be seeded at the last cultivation of corn or cotton. It is much prized in orchards where it can be seeded in the late summer and plowed under in the early spring, thus permitting cultivation during the growing season when the moisture is desired for the trees rather than for grass or other crops. A good seed bed is always desirable, although crimson clover may be sown on any kind of land, providing the seed is covered. The peg-tooth harrow is an excellent tool to give proper covering. In preparing the soil the aim should be to secure a fine, compact and moist seed bed. If plowing be done just previous to seeding, the harrow and roller should be freely used, so as to secure a compact bed.



CRIMSON CLOVER

Most popular in the South for land-improving effects. It is seeded in the fall and either plowed under preceding corn or cotton or harvested for hay and then followed by corn. It gives excellent results in orchards.

CORN.—The first thing is to see that the ground is in good condition and that the field intended for corn is given thorough preparation. The best results are usually secured on clover sod. This kind of land is full of plant food, contains a large amount of nitrogen and is usually in splendid tilth. The

depth of plowing depends, of course, upon the character of the soil and the locality.

After the soil has been plowed, the matter of thoroughly fining it is highly important. The disk has given excellent service in the corn belt, also the Acme harrow. The roller can seldom be used, as this packs the ground too much, especially if planting is followed by a heavy rain or two. Plan to have the upper soil as mellow as possible, so as to give the seed an early and a strong start. In many parts of the country it has been found exceedingly profitable to disk the corn ground before plowing. This forms a soil mulch and prevents rapid drying out.

Whether to plow in the fall or spring will depend upon the character of the land. If the field happens to be hard and cloddy for any reason it is very desirable to fall plow. Frequently, however, fall-plowed land has to be replowed again in the spring. Many people plow in the autumn and early winter, as they then have more time for this kind of work. It lightens the farmer's labor in the early spring. Where soils do not wash, fall plowing is very satisfactory.

Selection of Seed.—When the ground has been prepared in this thorough manner, the next important step is the selection of the seed. In choosing seed corn the important point is to get ears of the desired type and kernels that have a high state of vitality. If the corn has been preserved carefully during the winter and kept in a room where there is plenty of circulation and if it had been gathered early enough in the fall there ought to be no trouble about poor seed. Choose ears of medium size and wedge-shaped kernels. Shell the butts

and tips of the ears and discard these. These kernels, as a rule, will grow as well as the others, but in doing the planting it is very necessary, in order to secure an even stand, that the kernels be of uniform size; consequently, discard the large kernels from the butts and the small ones from the tips. After this has been done, the corn is shelled and it is ready for the planter.

It is not only necessary that the seed be from ears of the desired type and that the germ will grow, but it is also very important that the germ have a high vitality, which will enable it to grow rapidly and mature a crop early. Where drouths are liable to occur late in the growing season, this early start is a very important matter. Then, too, vigorous, healthy seed always produces a much better crop than seed with a lower vitality.

To determine whether or not seed has a high vitality, select 100 kernels, place them in a saucer full of sand or soil, moisten and put in a warm room, with a temperature of 70 to 75 degrees. Look at it from day to day. If the kernels sprout within four or five days and the germs come out uniformly, you may be pretty sure that the seed has a high vitality. If 90 kernels out of 100 sprout, you may consider your seed almost perfect.

Planting and Cultivation.—The thickness of planting is a matter of opinion. On a good soil, three kernels to the hill, using the ordinary check-row planter, is very satisfactory. However, large yields often result from five kernels to the hill. The ears are smaller, making it more difficult to husk, consequently thinner planting is much more satisfactory. This also depends somewhat upon the variety of corn. Corn with a small stalk and a

small ear can be planted much more thickly than corn with large stalks, a great abundance of leaves and large ears. Some people like to drill corn, but most think it is absolutely necessary to check it in order to give the corn the best cultivation and keep the land free from weeds.

Begin early so as not to allow the weeds to get a start. A smoothing harrow or any of the numer-

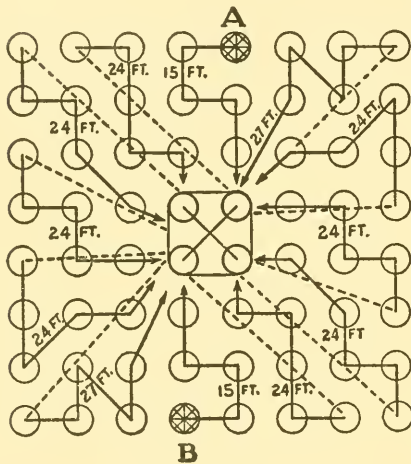

SHOCKING CORN

Most corn is carried from the row to the shock in a haphazard manner. To save steps is an incident seldom considered. Different plans are used by cutters; the one here shows how the work can be very advantageously done.

until the weeds get a start, or until the rapid growth of the corn is checked by a caked surface. When the weeder can no longer be used, take an ordinary two-horse cultivator, with three or four shovels on each shank, and cultivate about 2 inches deep, quite close to the plant.

By examining the root system of corn, you will find that the roots of the young plant do not extend over the entire surface at the earlier stages and the

ous weeders now on the market are excellent for early cultivation. If a heavy rain comes directly after planting, go over the field with a harrow or weeder just as soon as the surface becomes crusted. This weeder can be used until the corn is 3 or 4 inches high, going over the field as often as necessary. It is much better to spend a good deal of time on early cultivation than to wait

growth is not seriously injured by comparatively deep cultivation the first time. At subsequent cultivations it is desirable to cultivate more shallow and keep the shovels 7 or 8 inches from the plant. The deep cultivation should come early, so that the upper surface of the seed bed will be loose and mellow, thus preventing rapid evaporation of moisture. Later this deep stirring is not so necessary.

Cultivate Corn Thoroughly.—The corn plant will not thrive among weeds, nor in a hard packed, dry soil. The object of cultivation is to keep the soil in proper condition for the growth of the corn. The weeds will all be rooted up in properly cultivating the corn. It is not essential as to how deep or how shallow or how often the corn is cultivated, as it is that it is cultivated when it needs it. Especially after every heavy rain the soil is packed and should be

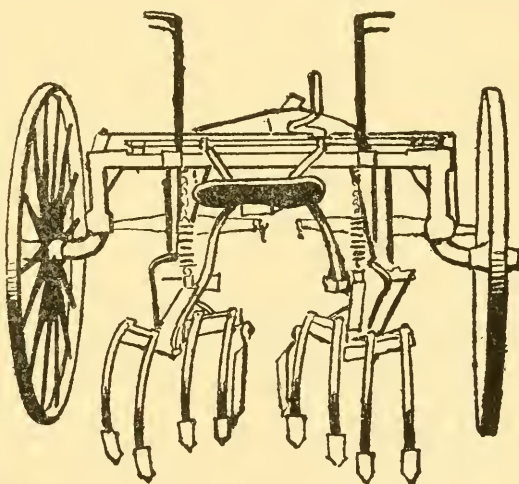

CORN CULTIVATOR

A necessary implement for the corn-field. The many fine cultivating teeth are quite a contrast to the old methods of corn culture of many decades ago. Then it used to be that farmers plowed corn; now they cultivate it to keep the weeds out, to mellow the earth, and to conserve the moisture.

Cultivation must continue during the whole growing season—and not stop with the third or fourth time over. The larger varieties, especially, must be cultivated with one-

horse after the corn is too big for the two-horse cultivators. A hard, baked crust should never be allowed to form in the cornfield until after the corn is in the roasting ear. Give shallow, close cultivation while the corn is young and deeper and farther from the hills as the corn gets older.

However, if on account of unfavorable weather, the corn gets weedy, any kind of cultivation that destroys the weeds most effectively is best. The kind and condition of the soil must determine the kind of cultivator. The disk does best in one place, the eagle claw in another, and the two, three and four-shovel gangs also have their places. On good, clean, well-drained land the two-row riding cultivators can be used to great advantage, while on rough or stumpy or stony land the two-shovel spring trip gang walking, or even the one-horse double shovel, and the hoe, must be resorted to. Keep the soil stirred and the weeds subdued.

Cultivating Corn the Last Time.—It oftens happens that after the corn has been laid by, heavy, dashing rains compact the surface soil, and when the ground dries out it cracks. Evaporation then begins to take place rapidly and unless something is done to recreate the soil mulch, the yield will be seriously curtailed. Some growers have used a sort of spading harrow just wide enough to go between two rows. It is drawn by one horse, and with it 6 to 8 acres a day can be gone over when the corn is so large that it cannot be worked with the ordinary cultivator. It pays to give this extra working, as the difference in yield sometimes amounts to as much as 8 bushels to the acre. The harrow can be a section of an ordinary spading harrow, or any kind of an implement that will break

up the crust to a depth of 1 to 2 inches. Just before the last working it frequently pays to sow seeds of cowpeas, soy beans or crimson clover to act as gatherers of nitrogen. If the cornfield can be pastured after the crop has been removed, farm animals can find a great deal of excellent feed from a crop sowed just before the last cultivation.

One of the important items in keeping the farm clean is to go through the field about tasseling time and pull out any noxious weeds that may be about ready to seed. This is necessary more especially with velvet leaf, cocklebur, jimson weed, dock, milkweed and the like. Some farmers feel that after the last cultivation the corn crop can take care of itself. While in a sense this is true, it must be looked after very carefully. Weeds must be kept down around the outer edge so that seeds will not be distributed through the field. Fences must be looked after so that stock cannot get in and destroy the maturing grain. Then, as noted above, the effect of heavy rains must be counteracted if possible.

Field Selection of Seed.—Seed corn should be selected from the stalk in the field and not from the crib or from the shock at husking time. Ears selected from the crib or from the shock are not always as valuable for seed as their appearance would indicate. The splendid appearance of such ears may be due entirely to the favorable condition under which they grew.

If we could trace these ears of fine appearance back to the field, we would find that a great majority of them had come from a plant where there was but one stalk in a hill, or where there were many missing stalks in the drill row. Where this

was the case, the ear had grown extra large and fine in appearance, because the plant upon which it grew had been favored with all of the plant food, all of the moisture and all of the sunshine that should have gone to two or three stalks.

Make the selection just before the corn is cut by passing through the field and spotting the desirable ears with paint. At husking time it is then easy to identify and separate them. If the corn is to be husked from the standing stalks, the selection is made just in advance of the huskers by passing through the field with a basket or sack, the selecting and husking being done at the same time. In either case, select ears only from stalks that are growing under ordinary average conditions of stand. Good ears growing under normal field conditions owe whatever excellency they possess to some hereditary force residing in the mother plant. These hereditary qualities are transmitted by the plant to the ear, which, when planted, will have a tendency to perpetuate the good qualities of the parent ear.

Ears which owe their excellency to favorable surroundings alone will not transmit their good qualities unless the favorable conditions are present the next season. The Ohio experiment station has conducted careful experiments along this line in order to determine the actual gain in production that might be secured by the field selection of seed corn. Ears were selected from plants growing in the field under normal conditions of stand compared with ears of the same variety and from the same field, but selected from the wagon instead of from the stalks before husking. The ears selected from the wagon were larger in size and of better appear-

ance than those selected from the stalk. Corn from the two selections when planted side by side showed an average gain for two years of 3.8 bushels an acre in favor of the plant-selected seed.

Another thing in favor of the field selection is the power to overcome or counteract undesirable characteristics in the plant. On rich, first bottom soil the corn has a tendency to grow very tall and to produce the ears high up on the stalk. This is undesirable, as it makes the corn difficult to handle and increase the tendency to go down during heavy windstorms. In field selections on such a land, pass by the ears that are above your heads and select only those that are produced at a desirable height on the stalk.

In the field, make the selection of seed ears with respect to normal stand, vigor of plant and the height of the ear on the stalk. In the sorting after husking, make the selection with reference to maturity, conformation to type and seed condition. If the storage capacity is sufficiently large this final sorting and selection may be delayed until a convenient time in the winter or early spring, otherwise it should be done as the corn is placed on the drying racks. In order to do this final sorting effectively and make an intelligent selection, have in mind an ideal ear and make all selections with this ideal in view. Color, shape of ear and other physical characteristics are considered and made to conform to the true ideal as nearly as possible. Discard all ears that are chaffy and immature. Very smooth, flinty ears are to be avoided because they usually have shallow grains and a low proportion of grain to cob.

The selected corn should be taken to a dry, well-

ventilated storage room and placed on drying racks. If allowed to remain in the bags or in a pile on the floor, the drying of the corn is retarded and as a consequence the ears may show lack of vitality the

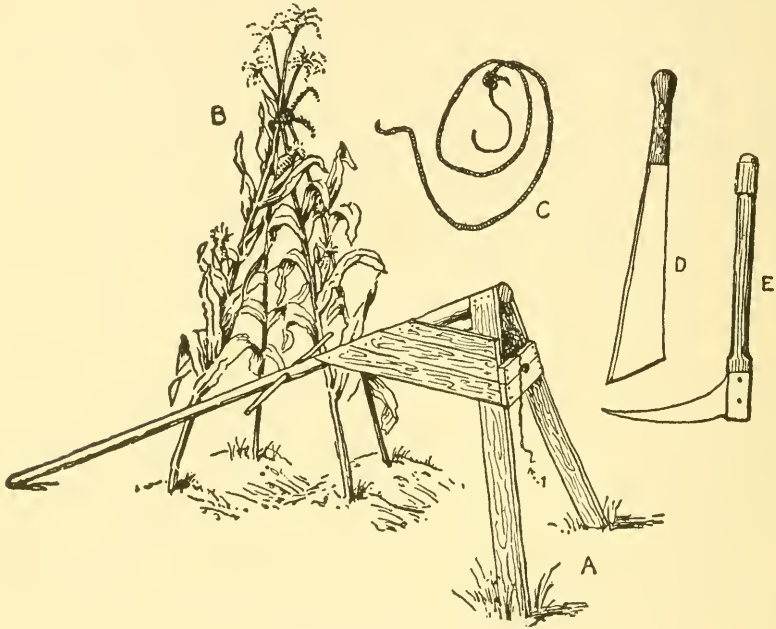

SHOCKING CORN

Where large quantities of corn are grown, the common method of shocking is to take four stalks as pictured here and to tie at the top, around which bundles are set. Some use the corn horse for the shocks. After starting the shocks the frame is withdrawn and the shock completed. For cutting corn different styles of knives are used, depending on the preference of the cutters. The real art of building shocks that will stand consists of having the bundles set straight and the shocks securely tied when completed.

following spring. It is of the utmost importance to keep seed corn from freezing, especially while it is still damp.

Preventing Damage by Crows.—Place a quantity of strychnine the size of a grain of wheat in a wide-mouthed bottle and fill the bottle about one-half to

two-thirds full of shelled corn, then fill with water. Shake the bottle to dissolve the strychnine, and let it stand two days, until the grain has swelled and absorbed the strychnine solution.

Just as the corn is coming up, or when the crows begin to pull it, scatter this poisoned corn broadcast over the field either in the form of a long line or cross in the center of the field or a large circle. When the crows alight in the field they will pick up this poisoned corn before they will take the trouble to pull the planted corn, and the first crow that eats this corn will shortly feel the effect of the poison and start for the woods. In doing so he utters peculiar cries or squawks, and sometimes will drop dead in his flight. Again, he may alight on a fence or adjacent tree, but before dying he usually has made such a fuss that other crows understand fully what the trouble is. Of course, the larger the flock that is with him the better, for they will all reach the conclusion that corn in the field is not proper to eat. It may be necessary to repeat the operation in a week or so, or perhaps sooner, if new crows visit the section. There are great numbers of crows wherever corn is grown and the damage they do is often very great. To save the corn destroy the crows.

Putting Corn in Shocks.—Corn will dry out better if the shocks are kept down to a reasonable size. From 100 to 144 hills are usually enough, especially if the stalks are not exceedingly large. When husking time is at hand, the corn ought to be fairly well dried out. Instead of putting the fodder of each shock by itself, set two or three together. The fodder will keep in fine condition and later on will turn out bright and free from mold.

If the corn shocks are to be hauled to the barn and husked and shredded by a machine, let a good frost or two first have a whack at the corn in the shock. A good freezing of stalk will do away with much trouble that ordinarily is found with shredded stover when stored in the barn or shed. My experience is in favor of the shredder, but I early

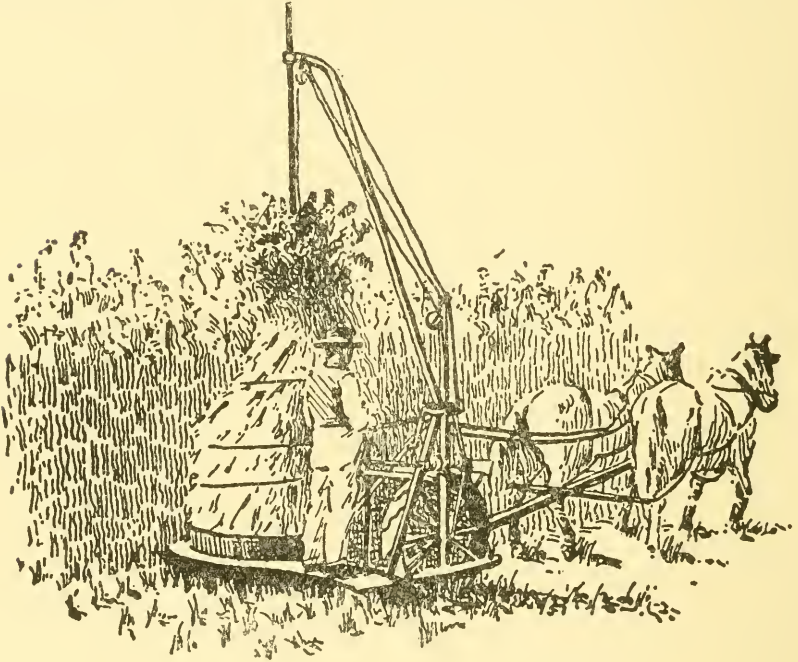

SHOCKING CORN BY MACHINERY

This implement builds the shock on a platform as illustrated. When the shock is completed, it is transferred from the machine to the ground by means of a derrick. The shocks are placed in rows.

learned that early shredding, before the season of frost and ice was on good and hard, is not to be desired. I have since delayed the work until early winter, and I have not one bit of personal testimony against shredded stover.

Husking from Standing Stalks.—It is in the West and South only that stalk husking is to any extent done. But the end is in sight for it in both sections. It is too great a waste for economical, wise farmers to approve. There has been reason for the practice in the West, because of large acreage and little labor. This, however, is righting itself. Crop rotation is working a change that will not only make farming pay better, but will increase the value of the corn crop.

While cattle and horses secure much feed from fields after the corn is husked, they nevertheless leave much, because frost has bit stalk and leaf and maturity has hardened and made unpalatable the penned-in food of the dry, hard, wooden stalk.

Hogging Off Corn.—While the practice of getting fall hogs ready for market by turning into the corn-field while still green is not new, it is a method not generally followed. There is a feeling that hogging off is wasteful and poor economy of labor and effort. But I have not found this to be true. The facts clearly indicate that the custom economizes labor and expense and the hogs do better. And that is the point—you get the most pork at the least expenditure of money. And what is more, the practice is past the experimental stage. Practical farmers have proven it through their own experience; and our experiment stations have verified these conclusions.

Not only do hogs produce more with less grain in hogging off, but they actually mature in less time than when pen fed. It is not unusual to save at least a quarter of the fattening period where this method is followed. I have found also that it is

just as easy to prepare land for a subsequent crop after a corn crop has been taken by hogs as when corn was removed in the ordinary way. Nor have I found that hogs waste a bit more grain by hogging off than there is lost by ordinary husking. Hogs pick just about as clean as huskers.

The labor item is not inconsiderable, either. A five to ten-acre field of good corn will carry 50 to 75 hogs from the shote to the finished period. Of course, the nature of the corn—whether the crop is heavy or light—will govern the number of hogs that can be fed in this way, but you can be certain that the total quantity of pork produced from a given acreage when hogged off will be greater than when husked ears or snapped corn is fed in pens.

Young hogs, weighing 80 to 125 pounds, are best to use in the green cornfield. At this age they are mature enough to do their best; they possess good frames and carry enough flesh to fatten in a few weeks and at the same time be just ready for market. Of course, brood sows will make good use of green corn also. When thin from suckling or for any cause unthrifty, they will quickly flesh up and improve and be ready for market in from 30 to 50 days.

While corn may be hogged off at any period, it is best to let it mature somewhat. Then you get all there is in the crop. If the ordinary summer pasture is short, give some additional feed like shorts and middlings in slop to tide along until the corn is fairly well developed. When it has passed the milk stage, and is somewhat dented, turn in; the hogs will do the rest.

Movable fences are to be desired that the hogs may be kept from running over the entire field.

When used, you need not make more than two or three movings during the time the hogs have the field. This makes the hogs clean up as they move along. But circumstances will govern as to whether you ought to use such fences or not. You will have to take expense, soil, nature of the season and length of feeding period into account. To give the entire field over to the hogs is the general practice when labor is high, the soil not wet, and the herd and field not large in size. Use old hogs, stock hogs and brood sows for cleaning up after the fattening bunch has been taken away. There won't be much left, of course, but still some; if this were not so, the fattening hogs would have been fed rather unwisely for the last week or two.

Saving Corn Fodder.—A ton of well-saved corn fodder is worth, if well used, the price of a ton of hay. Yet how rarely is it well saved or well spent! Exposed after husking to all the storms of fall and winter, it becomes musty, mildewed, washed, and weather beaten; hence a very poor fodder indeed. When fed it is thrown in the roughest and most careless way in the barnyard, where it is tramped down in the snow and mire, and the following spring is cursed as the greatest nuisance with which the farmer has to contend.

But let stalks be shocked up carefully, spread well at the butts of the shock and tied closely at the top until the corn is husked, and then put up in convenient bundles and again set up so that the rain cannot penetrate the shocks; and if as soon as cured it is carefully stacked or put away beneath the tight roof, it becomes an agreeable-looking, sweet-smelling, nutritious fodder, which will be readily eaten by all sorts of stock. **If it is cut up**

with any of the various fodder cutters, or if at husking time it is passed through the shredding machine, when fed it will be largely consumed, and the manure pile in the spring will be altogether free

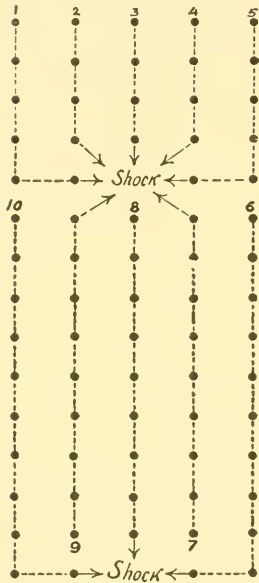

SHOCKING CORN

How the cutter can cut the corn and carry the same to the shock with as few steps as possible.

from the objectionable, unrotted and entangled stalks, while it will be quickly enriched by their fertilizing remains. If corn stover is properly cured, handled and fed the supply of feed will be economized, often leaving hay to spare for sale or permitting the number of the feeding stock to be doubled, and besides, what is often a source of trouble and annoyance may be turned to good account and money made by it.

COTTON.—While cotton has been cultivated from ancient times, it has been during the past one hundred years or so that the greatest improvement has come in developing it. Thirty years ago the South grew but 4,000,000 bales. Now the record is more than 13,000,000 bales. Cotton has largely

supplanted other fabrics and the day will come when a 25,000,000-bale crop will be necessary. There is available land in the South to make 30,000,000 bales with the present low average yield an acre. Of the 12 cotton states, only one acre in 17 is now planted to the fleecy staple and only one acre in 11 of the cotton-producing counties. From these figures can be readily seen what a gigantic crop is possible when the demand for the fiber comes.

Those familiar with the situation are convinced that the acreage now devoted to cotton is sufficient in every way to supply every call from the cotton manufacturing world. In favorable seasons the methods now in vogue can be expected to give as large a crop as the market demands. If more acres are given to cotton, the production will be greatly increased but there will not be enough spindles to use it.

To seek any material increase at present the cotton acreage would call for lands now less well adapted to the crop or for those now used for other profitable enterprises. These areas should not at present be disturbed. It is more important just now to get rotations started, pastures established, and live stock fixed into the scheme of Southern farming. When these things are done it will be time to plan for more cotton.

The key to successful cotton making is not hard to find. When cotton follows cowpeas or other crops that add humus to the soil, it is profitably grown. When lands have been tilled with big plows, when good cultivation is given during the growing period, the yields will run all the way



UPLAND COTTON

The two species of cotton grown in the Southern states are Upland or Short Staple and Sea Island. The plant is a small annual shrub averaging 3 to 4 feet high and branching. The flowers are white or cream colored the first day, become reddish on the second and fall on the third, leaving a small boll enveloped in the calyx. This boll develops until it reaches approximately the size and shape of a hen's egg, when it splits into three to five cells, liberating the enormous black seeds covered with the fibrous wool which constitutes the cotton of commerce.

from one to two, or three bales an acre. This is the practical way to increase the supply of cotton. It is not to scramble for more acres, but for more pounds to the acre. At the prices that have prevailed during the past few years cotton farming is profitable. At the prices that prevailed a decade



COTTON BOLL

The boll has just opened. The white fiber is easily detached from it. Picking cotton consists of pulling this white fiber from the open bolls.

or so back cotton farming, as every man who has grown it knows, was not then a profitable enterprise nor will it be now any more so than wheat at 50 or 60 cents a bushel or milk at 2 or 3 cents a quart.

South Will Hold Cotton Monopoly.--

Some folks are disturbed about the old world lands that may be induced to wed with cotton. Who knows? While it is possible for new cotton

growing sections to be developed, the fact still remains that now, and in all time to come the Southern states will control cotton production and hold fast to the monopoly. Cotton farmers do not need to disturb themselves about what the future will bring forth. Certainly, any attempt to flood the market with cheap cotton in order to keep other

sections from developing the crop is not the policy to pursue, nor will it be considered for a single moment by anyone who sweats in the cotton field. That argument might just as well be directed toward wheat, or corn, or live stock or any other agricultural specialty.

The first step in cotton farming is to give the present acreage the best sort of tillage possible. Too many farmers make cotton at a loss. While some cotton growers may be getting rich through cotton, on the average farm the crop just a little more than holds its own and does just a little better than to pay its own bills. The crop requires much seed, large quantities of fertilizer, a tremendous amount of hand labor and horse cultivation—besides the harvesting must be done by hand. It is, therefore, an expensive crop. As the average yield is under 200 pounds an acre, there is no immense wealth in the business. What is really needed, is not more acres, but the acres now used for cotton to have better care and closer attention. That's the way to make more cotton. That's the way to keep the supply up with demand. That's the way to keep the monopoly in this country and to make cotton growing a profitable industry.

How to Help Cotton Lands.—As matters now run the humus is being burnt out of the soil right along, the gullies still creep in and wrinkle the land and the soils yield no more, often less, than formerly was the custom. As long as cotton is planted on the same land year after year, as long as the soil is slovenly plowed and prepared, as long as humus is denied, as long as crop rotation is ignored and seed injudiciously selected, the average yield will remain ridiculously low, the needs of the world

will be indifferently met and the cotton lands will not be improved. There must be redirection back of cotton farming.

This redirection must include cowpeas and clover, stable manure, crop rotation, deep tillage and modern tools and implements. If the same total of manures, tillage and cultivation be given 25 acres that now go to 50 acres and the other 25 acres be turned over to corn and cowpeas, more profit will be realized in the end. Our real good cotton farmers are the proof of this. The average cotton farmer must seek success by throwing aside the obsolete one-horse plows and use in their place modern two-horse plows that will go down to reasonable depths in the soil. And this work should be begun as early as possible. Not in the spring after the cotton season has started; but long before, in order that the land may be opened, aired, stirred up. After this has been done disk occasionally to release plant food and to get the soil into the very best physical condition. When the planting season approaches, the harrow teeth should be set deep into the soil to fine and mellow the earth and to let the fat of the land ooze out that it may be at hand when the young roots have occasion to use it. These steps call for close application, but if to them are added good seed and vital manures an increased crop will surely result.

Other Crops Should Be Raised.—In addition to cotton there should also be legumes, corn and other crops. Exclusive cotton growing is fast giving way to mixed farming. Diversification is now the order and every cotton farmer must get in line. Corn and cowpeas should be given places of equal importance with cotton. Not small, inconspicuous corners, but



THE QUEEN OF AMERICAN CROPS

At the top is shown a second cutting of alfalfa. At the bottom the fourth crop of the season, with pigs helping to harvest it.



IN THE LAND OF COTTON

Familiar scenes in the South. After being picked the seed cotton is ginned, the seed sold or returned to the farm and the lint pressed into bales and sold to the mills of this country and Europe.

big, broad fields where both crops can spread out, expand and prove their worth. Both crops are needed—the cowpeas to rid the land of grass and gullies; and the corn and cowpea hay for grain and forage.

To make more money out of cotton more acres should be given over to food crops. Food stuffs for the family and for the stock should all be grown on the farm. With much pasture and a good corn crop you can grow your own meat, feed your own stock with home-grown supplies and be largely independent of imported offerings. The garden should be enlarged and included in it many winter crops. So also the dairy herd, in many cases, should be increased. With butter, milk, meat, poultry, eggs, fruit, vegetables and a dozen other products raised on the farm, both for home use and for sale, Southern farming will grow more profitable and the cotton crop as clear money will give the South a financial prestige that no other section can rival.

You see the South has been buying too many things raised elsewhere. If the corn, hay and meat bills only were saved to cotton farms, in a decade the change would be observable in a dozen ways. Instead of these farms being importing farms, they also should send to towns and cities human food on the same loads that carry the raw product for clothing. Consequently there ought to be much pork and beef each year for sale; and the manure made from this farm stock will make the cotton crop still more profitable. The cottonseed meal, instead of being shipped to Europe and the North through this redirection of Southern farms, would be more and more consumed in Southern farming, thereby building up Southern lands to make Southern stock feeding still more profitable. And the money made

by cotton in this way would be kept in the South, instead of being sent west for meat and feed.

Best Kind of Cultivation.—Make a stand for good seed. And what is also quite to the point, select your own seed. Give the crop better care.

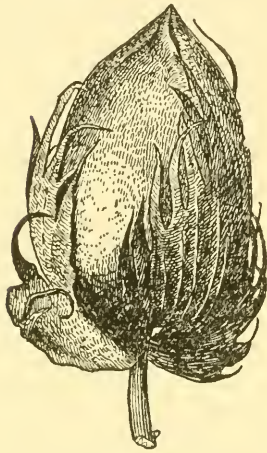

COTTON BOLL

The house of seed and lint. In it are from three to five or more cells in which are lodged the commercial products. The size, shape and general appearance of cotton bolls are characteristic of each particular variety.

Begin the cultivation early. Start with the weeder or fine-tooth harrow. I have seen much cotton and I have grown some myself where a hand hoe was never used. Some will hesitate at the start to eliminate the hand hoe. The doubting ones can continue to use the hoe, but let it be after the fine-tooth harrow has gone along the rows tearing grass and weeds and thinning out some of the stalks; for the finishing touches the hoe can then be used. The harrow in the early stages will also put the soil in excellent condition. It will warm the land, much to the pleasure of the cotton plant; and the millions and

millions of grass seeds that lie at the top, sprouting or just ready to sprout, will be destroyed.

Then, too, better care must be taken of the bales. While the moisture they may take up when exposed to all kinds of weather tends to increase the weight, it is fictitious and does not represent value; it is also a dishonorable way to get something for nothing; and to say that others do it is not to meet the question face to face. On the one hand, while a

cotton bale so exposed may weigh a bit more, on the other its quality is lessened. It is, therefore, doubtful if the advantage of water weight is not overcome by the loss in quality, and subsequent lower price. This cotton secret has been so generally exposed that consumers are now on the lookout for it. Even though the buyer in your immediate locality is not discriminating, ultimate buyers and the consumers are, and they pay less for the bales that have not been protected from the elements. Somebody along the lines, therefore, profits by discrimination, but in the long run it is not the cotton producer.

The market problem is also very troublesome. If cotton were marketed gradually as are other crops, there would be less variation in the prices that rule from September to July. The many growers who are forced to market early force the price downward to the joy of the speculators, and millions are lost to cotton growers, much of which is pocketed by cotton middlemen. It follows that it is a wise plan to keep out of the hands of storekeepers and money lenders. All cotton growers should preach the gospel of independence and urge their brother growers to raise the home supplies in order to keep out of debt. To be in debt for fertilizers and provisions is to jeopardize the value of cotton. When forced to sell cotton in the early market with the price low and the demand small, the weakest grower gets the long end of the pull and he finds it difficult to keep going. If one is not in debt to the store or to a money lender or cotton factor, he will be able to market his crops slowly and as the price justifies.

COWPEAS.—Too much cannot be said in praise of the cowpea. What clover is to the North, the

pea is to the South. On the poorest, sandy land, with 200 or 300 pounds of fertilizer, a crop of cowpeas can be made that will simply astonish a novice. Not only an abundance of choicest grain can be made from them, but the hay one acre will yield will three times pay the cost of the crop. The hay, if properly cured, is not just common rough feed, but in nutrition is unsurpassed. Horses, mules, cattle, sheep and goats will keep fat on the hay alone.

The valuable effects of a pea crop can be seen in the land for several years. Land that is hard and inclined to run together, if treated with a crop of peas, will for several years after be open, easy to pulverize, and much more productive. Many farmers who have tried cowpeas and condemned them made the mistake of planting them too early; peas should be planted when the weather becomes warm. The land should be prepared and fertilized as for corn. Three of the best standard varieties are the Clay, a variety that will not rot, if left after ripening, and a heavy yielder; the Carson, a tough shuck pea that will not shell out readily when vines are cut, a heavy yielder and very hardy, the best for hay of any variety; and the old reliable Whippoorwill, which is a good variety where grain is most desired; and will bear for several successive weeks if the ripe ones are picked off. Other varieties and all good ones are the Iron, Blackeye, Wonderful and Taylor.

Because the cowpea is a native of the South some Northern farmers think they cannot grow it. This is a mistake. Indian corn is also a native of the South, but even the Indians by persistent selection acclimated it in Canada. The cowpea is a good soil enricher, and it will grow under more adverse

conditions than will clover. It is the best plant to start poor, sterile, abandoned fields on a course of usefulness. When all other plants, even rye, make a sickly showing, cowpeas, under good cultivation and a light application of superphosphate, make a fine growth. When plowed in, the soil is improved mechanically, and much nitrogen added. The cowpea will grow on poor, rough soil if a decent seed bed is made, and a little food used to start them.

Do not be discouraged if the first sowing does not make much showing. Plow it all in as soon as

frosted, and sow the land to rye, using 1 bushel an acre for a winter cover crop, to hold the soil. In May, when the rye is about to head, plow it down and make another seed bed for the cowpeas. The soil becomes inoculated with bacteria the first crop and now the cowpea will be enabled to take more nitrogen from the air.

Naturally the soil will be more congenial and the growth surprising. As a nitrogen gatherer, a humus maker, and a consumer of rough plant food, the

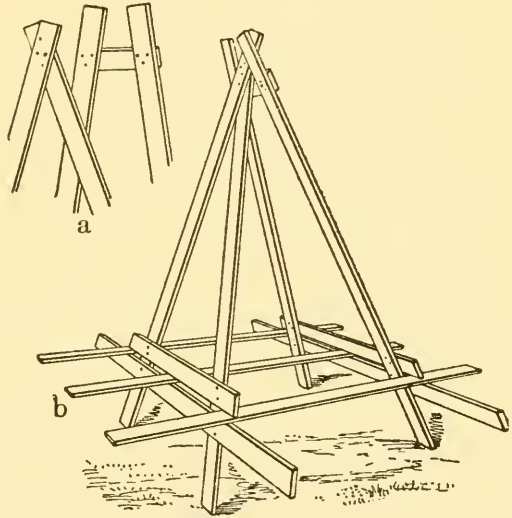

COWPEA RACK

While a great deal of cowpea hay is cured on racks, the greater part of the crop, especially in the South, is cured in a windrow, or in small shocks weighing from 100 to 300 pounds. A rack such as is here pictured is very excellent, but it adds much to the cost of curing the hay.

cowpea is not excelled if ever equaled by any other plant.

As a Food Plant it is rich, succulent, palatable, with a high per cent of protein. It remains in a good condition longer than most other soiling crops. As a silage crop it is also good if mixed with corn or sorghum, but by itself it will not cure very well in the silo. As a hay crop it is excellent, but



COWPEA SHOCK

A shock of green cowpea built on the peavine rack. When shocked in this manner, the hay is left in the field until thoroughly cured, when it is either stored in the barn or placed in large stacks or racks.

hard to cure in good shape. Its heavy vines and thick, fleshy leaves dry slowly. If sundried and handled much, the leaves will be lost. The best method to cure cowpeas is to allow the vines to wilt completely, and then put up in narrow high cocks, allowing them to remain thus for

about a week. It is usually cured through and can safely be stored. Do not make the cocks too high or the hay will mold. The cowpea is a tender bean, and will be killed by a frost the same as a garden bean, but heat, drouth, insects, fungi, etc., it fears not; it will overcome even weeds and continue to make its growth until nipped by frost.

The cowpea will respond to good tillage. A well-fined, loose seed bed is the ideal one. Never plant until the ground is warm. Sow broadcast or with grain drill at the rate of one to two bushels to the acre. If sown broadcast the seed bed should be well prepared. When the seed is sown the land is well harrowed with a disk or cutaway. If planted in drills make rows about 28 inches apart, and cultivate a few times. This not only hastens the growth, but increases the yields considerably. The saving of seed is also an item in planting in drills, as only half as much seed is needed by this method.

Cowpea Hay.—In feeding value well-cured cowpea hay is similar and about equal to alfalfa and red clover hay. Curing of cowpea hay requires especial care to avoid the dropping of the leaves, which occurs if the vines are overripe when cut, or if in curing they are too long exposed to sunshine. Cut just after the dew is off, turn the vines several hours before sunset and put in windrows or cocks toward the middle of the next day. Hay caps are very useful in curing pea vines. German millet has been satisfactorily used for the same purpose with the early varieties of cowpeas, sowing 1 bushel of the latter and 1 peck of the millet per acre.

DURUM WHEAT.—The group of wheat that furnishes the great bulk of macaroni paste. Until recently these wheats were grown quite entirely outside of the United States. The experiments made in this country have been favorable to their production and large areas are now annually given over to the durum varieties. These wheats are desired in this country because of the hard grain. No wheat has such a hard, flinty character as the durum. The plants are somewhat different from

ordinary wheat. They are rather tall; the leaves are smooth; the heads slender, sometimes short, but compact and always bearded with very long beards. The grains are a whitish yellow, rather long and very hard.

This wheat likes a soil rich in vegetable matter and therefore rather fertile. Its choice is for a hot,

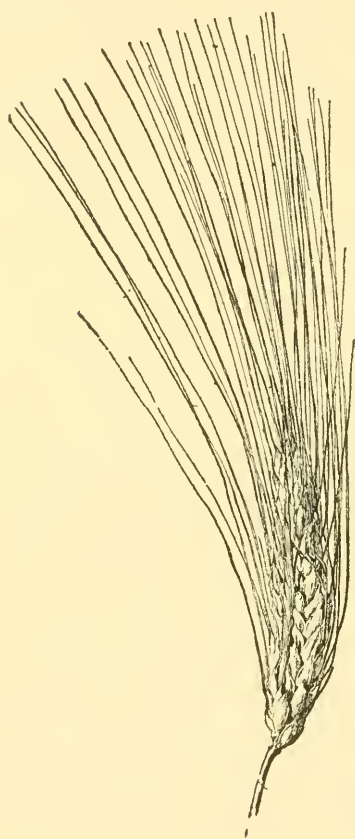

DURUM WHEAT

The head is heavily bearded, much more so than the ordinary wheats. In appearance it is much like barley. They vary in color from light yellow to almost black.

dry climate, and soils of an alkaline nature are much liked. Durum is raised very largely in the great plains district. There soil and climate are favorable and the wheat resists the drouth more successfully than most other crops. Now that durum wheat growing has become fully established its acreage will increase to meet the demand for the macaroni and other forms of edible pastes.

EMMER.—A very old wheat cultivated from the most ancient times. Its growing so far has been limited to Northwestern states. It is prized there for its drouth-resisting qualities. It thrives best in the dry prairie region and seems to like the hot summers. Its use has been limited so far to

stock food. Its feeding value is very similar to wheat. The yield runs well, anywhere from 25 to 60 bushels to the acre in the arid Western wheat district. Both winter and spring varieties are grown, the spring varieties being the most popular. It is doubtful if emmer will enter very largely into the stock food crops of the country. It can be used in sections where the soil and climate suit, but the area is likely to be limited.

FIELD BEANS.—Beans do their best on an inverted clover sod. The larger and later varieties seem to be more grown where the agriculture is more diversified, where more potatoes and corn are grown, and a four or five-year rotation is followed. In these localities the beans are usually planted on inverted sod land; but sometimes follow corn or potatoes. Since they come off the land too late to allow of proper fitting of the latter for wheat, they are usually followed by oats or other spring sown crops. Early plowing is essential to best results with beans. The time of planting varies somewhat with locality. Early planting of beans is not to be recommended. The seeds rot quickly if placed in soil too cold or too wet for quick germination, and even if a fair stand is secured the young plants do not get an even start. At harvest time, this unequal start results in uneven ripening—one of the troubles of the bean grower. If planting be delayed until the soil is thoroughly warm, uneven ripening is not so likely to occur.

Nearly all growers plant beans in drills. The distance between drills varies from 24 to 32 inches, and is usually 28 inches. The ordinary grain drill is used almost exclusively for planting the small varieties, stopping the tubes that are not needed.

Special bean planters are more used in localities where the large beans are grown. The amount of seed required to the acre varies with the variety. Of the small beans, many growers plant one-half bushel an acre, though some claim better results with three pecks, or even one bushel. Five or even six pecks to an acre of kidney beans are recommended, and intermediate amounts of the other varieties according to size.

If soil conditions are right, beans come up quickly and the cultivation may begin early. When they first appear above ground the young plants are tender and break easily, so that care is required in working among them. The weeder cannot well be used on the field at this time, though some farmers use it after the plants are forward enough to have become somewhat toughened. Cultivators of various design are used in the bean fields. The wheel tools cultivating two or more rows at a time are coming much into use. The culture required by the bean is similar to that of other intertilled crops. The cultivation should be frequent enough to keep the weeds from starting and the crust from forming on the surface of the soil. Cultivation should not be given while the leaves are wet with dew or rain, as the soiling of the leaves seems to favor the development of disease.

FIELD PEAS.—These grow upright for a time and then, unless sustained by other grain sown along with them, they fall over and complete their growth in a recumbent position. This trailing habit unfits field peas for a pasture crop, excepting for swine. Their chief value is for forage. They may be used either for hay or soiling. They are most frequently grown along with oats. The best

soil for peas is a porous moist clay loam. They will not do well in wet lands. Sandy loams are good, provided there is an abundance of moisture. Good preparation should be given the soil previous to seeding. Fall-plowed land is the best. They are most frequently planted in combination with oats. In a general way two bushels of oats and one bushel of field peas are used to the acre. These may be mixed before seeding and sown broadcast or with a drill. The best results are obtained by sowing the two crops separately. The peas are scattered over the land and disked in to a depth of 3 or 4 inches. Following this at once, or shortly after, should come the oats either in the grain drill or by hand and broadcasted.

The peas will stand a greater depth than the oats and do better if covered 3 or 4 inches deep. The two crops in combination work excellently. The oats give the peas support that they need and the peas add nitrogen to the soil and through the bacteria supply much that they need for their own growth. When oats and peas are grown as a dual crop the harvesting is about the time the oats are in the milk. As a hay it is both appetizing and nutritious and as a food for dairy cows is unsurpassed. In many dairy sections the custom prevails of seeding each spring a small acreage to oats and peas to get an early soiling crop. When the crop reaches a height of a couple of feet daily cuttings are made and these are given to the cows as green forage. If the clover or alfalfa crops are available or the pasture is ready before all of the oats and peas are used up it is customary to cut the remaining part and use as hay.

FLAX.—In this country flax is grown primarily

for seed. The demand for linseed oil makes the growing of flax profitable in some sections of the country. Then, too, the by-product, or linseed meal, is extremely valuable as a stock food. For this crop a moist, deep loam having good drainage is best. This applies for both seed and fiber varieties. Inasmuch as flax is a heavy nitrogen feeder the soil must contain an abundant supply of this fertilizing element. This is most cheaply obtained when clover and other legumes are grown. In seeding as soon as the weather settles and the ground is warmed up, the seed is sown 2 or 3 pecks to the acre. A heavier seeding than this crowds plants and lessens the seed yield. Heavier seedings are preferred for fiber and in this case from a bushel to two bushels of seed are used to the acre. The heavy seeding prevents the branching of the stalks and induces a single stem instead.

For fiber the seed is spread broadcast and for seed both broadcast and in drills. When the seeds are full and plump and have good color, it is time to harvest. The binder is used for the purpose. When the bundles are cured they are put in small stacks or stored in the barn until threshing time. A common grain threshing machine will serve the purpose well. The yield of flax seed runs from 8 to 15 bushels to the acre.

GERMAN MILLET.—See Millets.

HAIRY VETCH.—See Vetches.

HEMP.—An erect annual grown for its fiber-bearing qualities. This fiber is taken from the inner bark and is closely bound together by resinous gum. The rich, well-drained bottom lands are best for hemp, but uplands, if fertile and moist, may be used. Much moisture is an essential factor

in growing the crop. The usual seeding time is in the spring about the time oats and spring rye are sown. For fiber about a bushel of seed is used to the acre; the seed is scattered broadcast and harrowed in. No cultivating or weeding is required during the growing period.

Hemp is a ravenous feeder of nitrogen, calling for heavy applications of barnyard manure or legumes like cowpeas, soy beans or vetch to precede it. Heavy applications of fertilizer are also advisable, cottonseed meal being especially good. About 200 pounds can be used to the acre. In addition to the meal, 200 pounds of acid phosphate and 200 pounds of sulphate of ammonia are recommended for poor soils. Harvesting takes place when the fiber is in full blossom. It is cut with a heavy reaper, the stalks close to the ground. The bundles are left on the ground until they are rotted by the dew and rain, then shocked like corn and tied in bundles or stacked. The yield of fiber varies from 750 to 1,500 pounds to the acre. The higher the plant the heavier the yield. It is estimated that an increase of 12 inches in height means an increase of 150 pounds of fiber to the acre. The fiber sells for from 6 to 8 cents a pound.

Some hemp is sown for seed, which is used as bird and poultry food, and for making oils to mix with paints and for soap making. If seed is wanted, the seeding should be made in rows or in hills with cultivation similar to corn. Use about 2 quarts of seed to the acre. The harvesting is similar to corn. The stalks are made into shocks and tied. When thoroughly dry the threshing takes place, usually with a flail. The yield varies from 30 to 35 bushels to the acre.

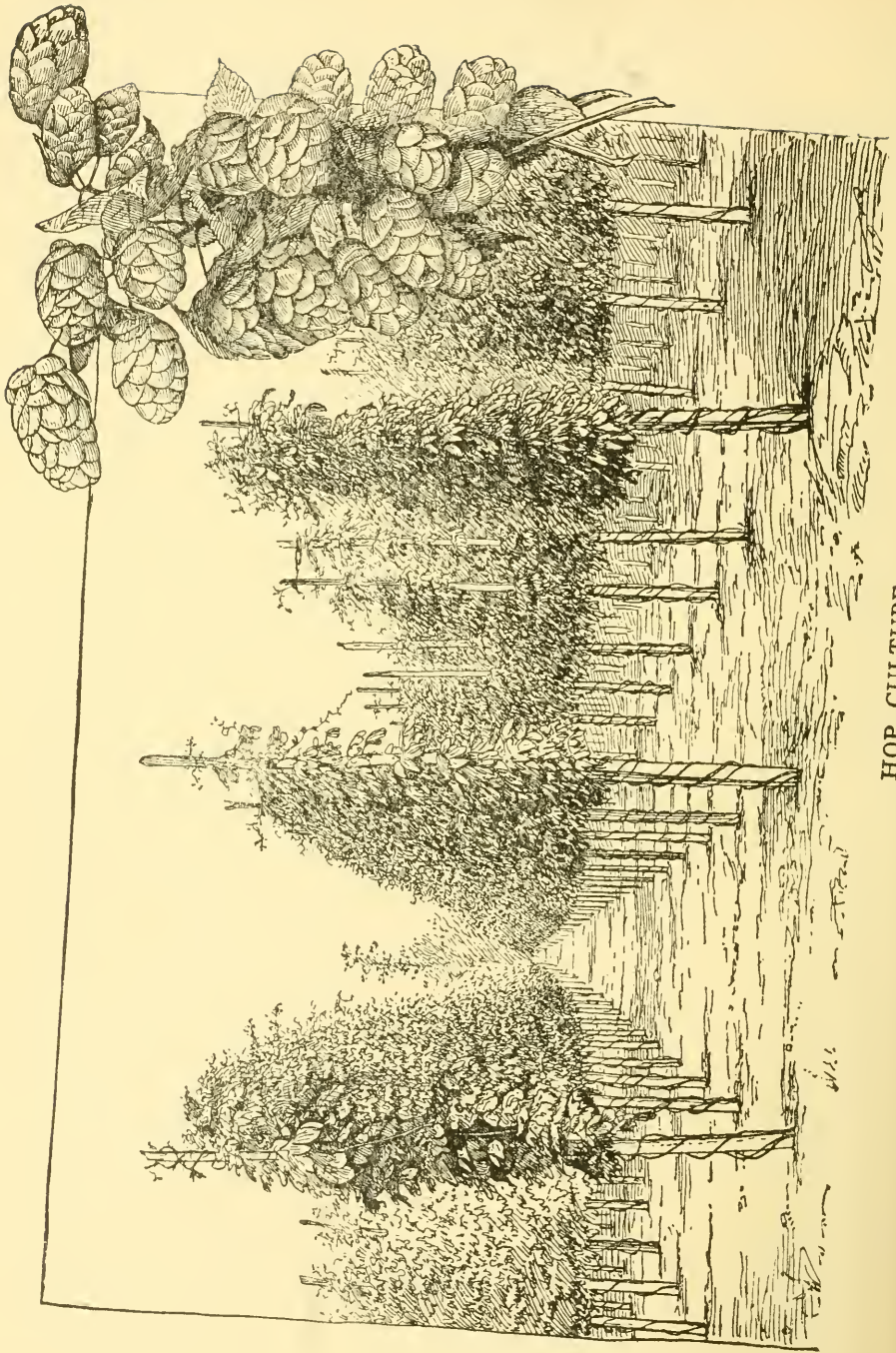

HOP CULTURE

HOPS.—This perennial climbing vine is grown principally for its use in beer making. The foliage is harsh, the stems rough and the height from 10 to 25 feet. While hops can be grown nearly everywhere, they are cultivated in only a few places. California and New York are the leading hop states. A sandy loam relatively fertile is preferable, and it should be moist, although not wet. Some manure should be given to each hill and worked well into the soil where the plant is to grow. These heavy applications of well-rotted manure always pay. Liberal use of manure between rows is desirable.

The hop grows vigorously and makes its growth in about three months; therefore requires plenty of food if it is to yield its best. Roots are used in propagating. The root cuttings should be selected with two or more bud eyes and these laid in rows 7 feet apart each way. Two or three root cuttings can be given to a hill. It is best to place these 6 or 8 inches apart and to cover 2 or 3 inches deep with mellow soil.

When the hop vines have reached a length of about 2 feet they require training. One or two poles from 15 to 20 feet long are set firmly in the ground at each hill and on these the vines are trained. During the latter part of August or the first of September hops are said to be ripe and are then picked. The hop vines are cut down and the hops picked by hand into boxes, baskets or in piles. A good picker will gather from 150 to 200 pounds of green hops a day. After picking over they are cured usually by artificial heat and in the commercial sections in kilns. This work being a technical problem, experience and judgment are neces-

sary. These are learned only through practice. Following the drying comes the cooling and baling. They are put through a sweating process and then pressed into bales weighing about 200 pounds and sewed up in baling cloth.

HUNGARIAN MILLET.—See Millets.

INDIAN CORN.—See Corn.

ITALIAN RYE GRASS.—A quick growing grass and often used in permanent pastures. It fancies a moist, loamy soil rather rich in lime. When so provided, it makes an excellent hay. If reasonably well fertilized, in two months after seeding a good cutting of hay may be secured. For this reason it is prized as a soiling crop. It cannot withstand drouth and it does poorly on stiff, clay lands.

For hay, the cutting should be when in bloom. From 2 to 3 tons are usually secured to the acre. In seeding about 2 bushels of seed are required to the acre. If seeded in mixtures, half of this quantity should be used. Both fall and spring sowings are practiced. It usually runs its course in two or three years, and, therefore, is not valuable for permanent meadows. It is a good plan to have other plants like red top and timothy in the seed mixture to succeed as it dies out.

JAPAN CLOVER.—A Southern pasture grass and unsurpassed in some of the more southern localities as a hay crop. It grows on the poorest, barest red clay knobs and on the exhausted gravelly or worn-out sands and at the same time produces fair grazing. It is a legume and a good soil renovator. Its roots are richly supplied with nitrogen-gathering tubercles. In the heat and drouth of midsummer when plants like common red and white clover,

timothy and Bermuda grass are dried up or at a standstill in the pastures, Japan clover grows vigorously and luxuriantly holds its green and palatable qualities for stock until the heavy frosts come on in the fall.

Besides this, once started it spreads rapidly and crowds out the common and worthless plants of the neighborhood. Because of its thick manner of forage it withstands tramping and the closest grazing of stock. It is successful as far north as Maryland and as far west as Kansas and Texas. Its greatest usefulness is from Virginia southwest to the gulf. Japan Clover is an annual and dies down each year, leaving its stems, leaves and roots to decay and enrich the soil. From the soil which falls to the ground or which is scattered by the wind or in the manure of grazing animals the crop of the following year is produced. It is not a weed and can be eradicated by plowing as easily as red clover. It is a low spreading plant, standing from 8 to 12 inches in height. On poor, dry soils it spreads out flat and may not exceed 3 or 4 inches in height. Farther to the south, where it makes good hay, it frequently attains a height of 2 feet and as much as 2 tons of hay are made to the acre. It is, however, a crop primarily for pasture and for soil renovation. To secure the best quality of forage it should be kept pastured rather closely, as the more mature plants get woody near the base. It is practically impossible to graze so closely as to prevent reseeding. This clover is seldom seeded in pastures, but is allowed to come in naturally. It is so valuable, however, that this is too slow a method to obtain its rejuvenating effects for the land.

It would pay to sow the seed as any other crop. In seeding a light harrowing will not be amiss, but the ordinary rains will sufficiently cover the seed. When warm weather approaches it grows rapidly until frost comes. Its greatest value is as a restorer of worn-out fields, and to do such work it stands unequaled among the renovating crops of the South.

JAPANESE MILLET.—See Millet.

KAFIR CORN.—As a substitute for corn in the semi-arid regions of the West kafir corn is a great success. It grows from 4 to 8 feet in height. The stalks are thick, rather short jointed, with broad leaves much like corn leaves. The grain is centered in the head, which is compact, ranging from 10 to 16 inches in length. There is not much nutrition in the stalks. The leaves, however, are good and very good yields are obtained from each acre of the grain. The yield ranges from 35 to 50 bushels to the acre. In good years, with a reasonable amount of moisture and on rather good soils 75 to 100 bushels of grain may be secured.

Grown side by side in these dry sections kafir corn as a rule outyields Indian corn. Varieties in general cultivation are the red, white and black hulled. The red and black hulled are the best yielders and both are hardy. The grain is used as a substitute for Indian corn. It is used very successfully for feeding horses and for fattening hogs and cattle or other farm stock. For fattening purposes it is not far behind Indian corn. Since the yield in these dry lands is greater with the kafir corn a little more pork is usually secured to the acre from growing it than from the Indian corn. Kafir stover looks very much like or-

dinary stover, but is not so palatable. When grown for hay kafir corn is seeded broadcast and if the crop is cut when the grain is in a dough stage a great deal of forage will be obtained. When the kafir corn crop is cut, if this be done early in the season, a second crop frequently grows up and not infrequently this second crop can be used for pasture. Considerable damage to live stock has resulted from pasturing the second crop. Bloat is not uncommon and often the animals die with all the symptoms of acute poisoning. The real reason for this is not known.

The crop is adapted to all soils, but it fancies most the rich corn lands. It will do better in poor soils, however, than ordinary corn. If a sudden drouth comes on when other corn is completely killed kafir corn will curl up its leaves and cease to grow, but still hold life. With the first rain it begins to grow again just as if its life had not been threatened at all. If the stalks are cut and subsequent rains come, a second and often a third crop are possible.

In preparing for kafir corn, go about it just as you would for corn. A good seed bed is very desirable. When seeded in rows, about 7 pounds to the acre are sufficient. The rows should be 3 feet apart and the grains distributed from 4 to 6 inches in the row. If seeded broadcast for hay, use from 1 to 2 bushels to the acre. The grain drill is used very largely for seeding purposes. The custom is to close the second, third and fourth feeds, leaving the first and fifth feeds open. It is advisable to test the adjustment out before beginning to plant in the field. Since kafir corn is a warm weather plant, the planting season is usually after the regular corn

planting time. If planted when the ground is cold the grain may rot or make an otherwise poor start. During the first four or five weeks the growth is slow and the plant not so vigorous as ordinary corn. When the crop is matured the grain should not be taken from the stalks until fairly well dried. The custom is then to cut the tops or heads from the stalks and to let them thoroughly dry out in the field or barn. They are then threshed and stored.

The grain heats when stored in large quantities and for this reason often the germinating power is destroyed. Care must be taken in this respect to secure the next year's seed. Poor seed more frequently results from the way the grain is handled after threshing than from other reasons. In cultivating do just as is the custom with corn. Listing or level planting may be practiced. It all depends upon the locality and the soil conditions. Usually three to four months are required to mature the crop. When both grain and fodder are desired the corn harvester may be used for cutting, and shocking may be done in order to cure the stalks and grain. For general feeding during the winter time the shocks containing the grain can be hauled direct to the feed lot. The best results will be obtained, however, by threshing and grinding the grain.

KENTUCKY BLUE GRASS.—This grass does best on a rich, rather moist soil. On dry, gravelly soil it will start very well if sowed in the fall or early spring, but the hot, dry weather of summer will arrest its growth and it will make very little pasturage from July to September. In many places it comes up and maintains itself without sowing seed. When grown on a soil which suits,

it makes most excellent hay. When grown on dry, gravelly soil the hay is likely to be wiry and poor. It is more tenacious than the other meadow grasses and in time tends to run out the timothy. If once introduced, it is probable that it will go all over the farm, even into the fence corners. It will produce very nice pasture early in the spring, and if the land is fertile, late in the fall. It should be fully understood, however, that blue grass furnishes but little midsummer pasture on gravelly soil.

Blue grass starts early in the spring and is considered to be rather better for producing milk than young clover. In laying down a permanent pasture it is customary to fit the ground unusually well and sow about 1 bushel of blue grass to an acre, allowing 14 pounds to the bushel, with timothy, clover and orchard grass. It starts slowly and does not make a good pasture grass until about a year from sending; therefore, some other plants must be depended upon for the first year. Finally,

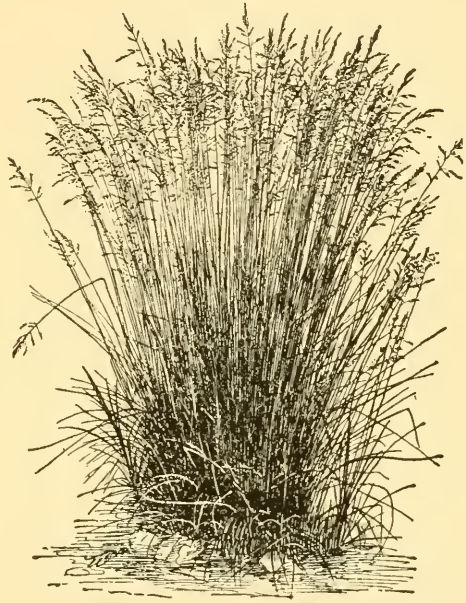

KENTUCKY BLUE GRASS

An excellent grass indispensable for permanent pastures. Once firmly established it returns of itself even though the land be plowed and given over for a short time to corn and wheat. It is not grown for hay. It is best appreciated in the Middle Western states.

do not sow it for pasture on gravelly soil, but the clovers, particularly the alsike, with orchard grass and timothy, since all of these furnish more mid-summer pasture than blue grass does.

LESPEDEZA.—See Japan Clover.

LUPINES.—A legume valued most for green manure. Up to the present time lupines have not entered to any extent into American farming. In Europe these plants are cultivated to some extent for forage, but even there they are most largely used as green manures. They are especially valuable for this purpose on the light sandy soils too poor to grow anything else. They are not suited to calcareous soils or to wet lands. Seed should be sown at the rate of $1\frac{1}{2}$ to 2 bushels to the acre following corn planting time. In the Far West, especially in Montana and Idaho, some of the wild varieties are grown in abundance and when cut very large quantities of hay are secured. It is not likely that these plants will enter to any extent in American agriculture.

MAIZE.—See Corn.

MAMMOTH CLOVER.—This strong, vigorous legume calls for much moisture and strong land. Like common red clover, it is a biennial and on congenial soils lives longer than the common red clover. It resembles the common variety in form and leaves and in general habit of growth. The stems and heads are larger. It attains to a greater height, matures later in the season and its roots are large and penetrate the soil to a great depth. One crop of hay is usually obtained and after that is harvested little pasture is secured. It grows its best in fertile soils and in warm and cold climates, but it does not have the wide distribution that the com-

mon red variety enjoys. It occupies the same place in the rotation and calls for the same methods of seeding and preparation that are given the common red variety. When sown alone, the usual amount is 10 pounds of seed to the acre, but when sown in combination with other seeds, this amount is proportionately reduced.

It is a good plan, and many farmers follow it, to seed mammoth clover and common red clover together. By so doing you get the vigorous early growth in the spring and the late growing in the fall of the red variety and you get the vigorous growing of the mammoth variety during the summer months. The mammoth variety is more inclined to lodge and is more difficult to harvest and to cure than is the small red variety. It yields a little heavier to the acre, but the hay is coarser and is not so popular with feeders nor so much relished by animals.

Mammoth clover is especially prized as a green manure. Some farmers who plan to plow under the crop preparatory to corn or potatoes, seed it for the soil effect rather than for its value as hay. The crop is pastured and often very severely. But the large roots and coarse stalks furnish the soil an abundance of vegetable matter, which is always to the liking of the corn plant when it follows after.

MANGELS.—Of all the root crops, the mangel-wurzel or stock beet is, perhaps, the most important, both as to feeding value and amount of yield to the acre. Turnips make a valuable catch crop, but the mangel must be sown early in the season and cultivated to secure a satisfactory yield. The freer the ground from weed seeds, the less arduous will be the work of cultivation.

The soil should be well stirred, harrowed and leveled. If possible, choose a well-drained location



THE SUGAR MANGEL

This is the Danish improved and is a favorite with many feeders. Its sugar content is much higher than the common varieties.

and give a liberal application of well-rotted manure. The seed may be put in with an ordinary garden seed drill gauged to sow rather thickly in the row to insure a good stand. The rows should be run

about 20 inches or 2 feet apart, as the tops soon fall over and shade the ground between, discouraging weed growth. As soon as the young plants can be seen, go along the rows and pull out all the weeds, giving the young plants a chance to get a good start. In a week take the hoe and cultivate the ground between the rows, thinning out the plants as you go along. This may be done by taking the hoe and skimming off the unnecessary plants near the top of the ground, using care not to disturb those you wish to save. Six inches apart in the row is as close as they should stand, and if the soil is in good condition and rich, 8 to 10 inches is better.

Give shallow cultivation throughout the season, or until the plants spread out and cover the space between the rows, when they may be left to their growth. They should not be harvested until October or November, when they may be stored like turnips and cabbage.

MEADOW FESCUE.—An exceedingly valuable plant for use in part in permanent pastures. It is of long duration and in the Southern states remains green over winter. Rich, moist clay or loam soils are most fancied by it, but it does fairly well on all kinds of soils, even if they are dry. Blue grass and orchard grass seem to resist drouth better than this fescue. When at its best it reaches a height of 4 or 5 feet, though 2 or 3 feet is more of an average when seeded with other grass seeds. It is a perennial and grows in bunches like orchard grass. It has stout fibrous roots, and rather abundant leaves that are from 1 to 2 feet in length. In seeding, from 2 to 3 bushels are used to the acre. It is seeded just as timothy is. The first year or two it is not conspicuous in growth, but after the

third year it becomes fully established. It readily yields from 1 to 2 tons of hay to the acre. The best time to cut is when the plants are in flower. It is a very good crop for overflow lands, as the overflows do not damage it. Its many good qualities should place it in every grass mixture, whether for pastures or meadows.

MEADOW FOXTAIL.—A hardy perennial much like timothy in appearance. The leaves are short, the stalks thick, making a rather coarse hay. It starts to grow earlier in the spring than timothy, but does not do very well alone. It takes about two years to get it fully established. For this reason it should be used as part of a grass mixture, either for permanent meadow or permanent pasture. When grown alone it yields from 1 to 2 tons to the acre. It stands high manuring, but has no inclination to spread like blue grass or Bermuda. Its chief value is in mixtures of meadows and pastures.



MEADOW FOXTAIL

MELILOTUS ALBA. — See Sweet Clover.

MILLETS.—A general name that includes many varieties of grasses. While this group includes many food products the millets are grown in this country chiefly for forage. Millet is a popular catch crop. If the winter wheat has failed, or for some reason the corn land was not fitted for the crop, a little later on the land can be prepared and seeded to some variety of millet. The three principal groups

are, Foxtail, Barnyard and Broom Corn millets. The most common varieties are identified with the first class, including Common, German, Hungarian and Golden Wonder.

Japanese millet is closely allied to the German variety. There are several different millets, however, that come under the name of Japanese. The Barnyard millets are known as barnyard grass and very common. In this country they are used exclusively for forage, although in India the grain is largely used as food for the people.

Pearl millet, a variety that has received a good deal of advertising in recent years, goes under many names, among which are *Penicillaria*, Egyptian millet and Cat Tail millet. This variety is erect, growing to a height of from 8 to 16 feet. It bears its seeds in a slender, cylindrical head which varies from 8 to 12 inches in length. It is a very succulent annual and there is much difference of opinion as to its usefulness. It is a heavy producer and may be cut two or three times during a season. It is not liked so well as a hay crop, because of the difficulty of curing. It is much valued for pasturing or soiling.

Millet is really a summer crop and likes warm weather. It also likes warm soils. It is frequently seeded in poor land, but the crop really requires a fertile soil. A strong objection to the crop from the soil standpoint is the fact that it feeds only near the surface. On account of the rank growth much moisture is necessary if a heavy crop is to be obtained. For this reason clay loams are best. In moist climates where the summer rainfall is rather liberal, the sandy soils, if fairly fertile, will produce abundantly.

The usual time to seed is after corn planting or any time during June. The seed bed should be deep and well prepared. The millet seeds are small and, therefore, a thorough preparation of the ground pays. About a half bushel to the acre is used for seed when the Hungarian, German or Common millets are grown, but when the Broom Corn or Barnyard millets are grown, heavier seeding is necessary. The usual custom is to seed broadcast and slightly cover with a harrow. In some places the seed is drilled. The crop can be cut for soiling in about two months and a period slightly longer than this will mature a crop of hay.

When millet hay is fed to horses disorder often results, placing the crop in the undesirable list of hay feeds for horses. No trouble has ever been occasioned when fed to other classes of live stock. When millet has been used as a soiling crop or put into a silo it has been very favorably used as a horse feed. It is advisable in harvesting to allow the millet to lay some hours before raking. The stems being large and succulent, some time is necessary for the drying-out process. A good practice is to put the millet in shocks from the windrows and to let the hay cure in the shocks for several days. In warm weather there is no difficulty in curing the hay, but if the season is against rapid curing, millet is more difficult to handle than clover.

Anywhere from 2 to 4 tons to the acre may be obtained. The Japanese variety yields very heavily and is one of our most desirable soiling varieties. Indeed the heaviest yielding millet is, without doubt, the Japanese barnyard variety. If grown for seed in good soils, from 65 to 90 bushels are procurable from an acre. On lighter soils the yield drops down

to 20 or 30 bushels. Japanese foxtail is a good yielding variety and when carefully grown in the same land as the preceding variety yields all the way from 40 to 55 bushels to the acre. Japanese broom corn millet gives a very heavy seed, but does not yield as much as the others. In the neighborhood of 30 bushels is considered a fair average for average soils. The German millet yields about the same as the Japanese foxtail millet.

While any of the millets are excellent as feed, caution must be observed when used as such. They should be fed sparingly and in combination with other foods. Their laxative action when green affects the digestive organs and if fed in too large quantities, disorders and disturbances arise. The seeds, when well formed, produce an injurious effect on the kidneys of the horse.

As a farm crop, millet has its place. While not generally used as a fixed crop in a fixed rotation system, it can frequently be employed with great satisfaction and profit. When the pasture and hay crops are short for any reason these can be easily supplemented by growing millet. Millet is fortunate in being usually free from fungous pests and insects. Whenever any of the fungous diseases or insects are found, they do little damage to the crop.

MILO MAIZE.—A non-saccharine sorghum. The plant tillers abundantly and produces tall, slender and succulent leaf stalks. The seed is in a compact sorghum-like head. Two varieties are cultivated: the white Milo and the yellow Milo. The first demands a long growing season to reach maturity, but the yellow is rather early. The habit of growth is erect and a great height is attained. The plants produce an abundance of leaves, all of

which are of fine quality. A rich soil is wanted, but in dry regions the kafir corn and ordinary sorghums are more popular than this forage plant. It is used only for soiling or as a fodder.

MUSKMELONS.—In growing melons the ground should be prepared about the same as for corn. It should be marked off 4 feet each way, using a one-horse turning plow, one way, furrowing out rows to the depth of about 6 inches. Use about one scoopful of well-rotted stable manure to three or four hills, being careful to get manure well down. Cover with soil and press it down well, then drop seed on top of same, covering about 1 inch deep. If troubled with mice taking seed, they can be controlled to a great extent with poison. Commence cultivation within a few days after planting; deep at first, reducing the depth as the plants come up and grow. When vines get too much in the way for cultivation, turn them all one way, keeping the cultivation up at least once a week until they begin to ripen fruit, if the season is dry. The cultivation should continue in proportion to dryness of season.

The greatest mistake in cultivating melons is running implements too deep after vines commence to spread. Remember the roots are near the top of the soil, spreading out from the hill about the same as the vines. After vines get a foot in length, the depth of cultivation should be reduced to not over 1 inch.

OAT GRASS.—See Tall Oat Grass.

OATS.—The oat crop ranks second in yield and third in acreage in the United States. But we usually take this important and sturdy assistant as a matter of course; we slightly appreciate its

greatness, and give it the least attention and care of any of our leading crops. On the average farm, where it annually fills its place so completely, so fully and so well, it is talked about, discussed and considered least of any of the crops on the farm. The crop does its work so constantly, so evenly and so uncomplainingly of either soil, fertilizer or season that we have come to think of it as steadfast and sure. This is, after all, a compliment rather than a slight, but it is not a very appreciative attitude to assume to so constant a friend.

Who talks about soil best adapted to oats? What fertilizer pays court to it? Who searches for its ancestry or shows the advantage of superior breeding? What friend enters the list to champion it? These things are not said complainingly, rather simply to call attention to one of our most meritorious and leading crops, that its culture, too, may be studied and the best skill given to its improvement.

While oats may be grown on any type of soil—poor clay, sandy loam, peaty land—the crop is at its best when favored with a well-drained fertile clay or clay loam. The choicest fields, as a rule, go to corn or wheat or cotton and the less desirable are turned over to oats, the owner knowing in his own mind that they will give a good account of their occupancy.

The Seed Bed and Seeding.—Good preparation of the soil pays for oats as it pays for other crops. The seed bed should be prepared by plowing rather than by disking and harrowing. This poor preparation often explains the poor stands and light grain and straw we often see. Heavy lands in the North may be plowed with profit in the fall, and in the

South they may be plowed during the winter season. Since the oat crop is hardy and can stand considerable cold and moisture, it is our earliest field crop to go into the ground in the spring. Hence early preparation of the soil aids in seed sowing as soon as winter weather has disappeared. A week or two gained at seeding time is to be preferred to an extension, when warm and drier weather comes.

It pays to give attention to the preparation of land. You should compact the soil, using the roller if necessary, and rid the land of clods and uneven places. The same care as that given to wheat or corn will pay with oats. In seeding use from 2 to 3 bushels to the acre. As commonly practiced, oats may be disked or drilled, but the latter has proven more satisfactory because of evenness of distribution and covering of seed. The seed should be covered to a depth of from 2 to 3 inches. Fall seeding of oats in the Northern states has not proven very satisfactory, the best time being from the last of February to the first week in April, the nature of the season influencing the time. Spring seeding in the South should be a month to six weeks earlier than the time suggested for more northern latitudes. The best time for seeding oats in the Southern states is between the middle of October and the first of December. They grow more or less during the winter months, get a good start when spring opens, and are matured before hot weather arrives.

Manures May Be Used.—Where corn has preceded the oat crop and been heavily fertilized with stable manure and chemical fertilizers as well, and during the season well cultivated, you have quite

an ideal preparation for oats. But some manuring will pay for the crop. Not stable manure, for that you can better employ on the clover or pea land for corn. If your soil naturally tends to "down" oats, use no nitrogen in the fertilizer, only potassium and phosphorus. Make your own fertilizer by mixing 1,800 pounds of 14 per cent acid phosphate and 200 pounds of muriate of potash, using about 100 pounds to the acre. For worn-out land a fertilizer consisting of 1,600 pounds of acid phosphate, 200 pounds of cottonseed meal, and 200 pounds of muriate of potash is a satisfactory combination for oats. From 150 to 250 pounds may be used to the acre.

Where oats follow cowpeas in the fall, or clover in the spring, the nitrogen constituent of the fertilizer may be eliminated and the first-named fertilizer used. The cowpea field, its crop of peas harvested and made into hay, is ideal for oat production. Plowing is unnecessary, since it is to be supposed that the land has been thoroughly broken as a preparation for peas, and now the disk only is needed to chop the stubble and loosen the top soil. The pea roots have gone deep into the soil, and have opened and loosened it for air circulation, and rendered the soil comfortable—a good thing to the less vigorous roots of the oat plant.

For Hay or Grain.—"I never let my oats ripen. I prefer to cut them early and make them into hay," said a speaker at an institute last summer.

"What is your reason for that?" was the question at once asked. He answered: "Because I am after hay, and when oats are cut while yet green and while still in the dough state, they make a most desirable feeding stuff in every way for all kinds

of farm animals." The speaker was correct in his estimate of oat hay. It is a superior feeding stuff. When cut sufficiently early, horses, cattle and calves relish not only the grain contained in it, but find the straw appetizing and nourishing.

In those sections where hay is always at a premium this method of harvesting is doubtless best, and even where hay crops flourish well it may still be preferable to make hay of the oat crop rather than to harvest the crop, thresh the grain and in the end to feed both straw and grain to the farm stock. Is this not worth thinking about?

"You wish to sell the grain," I hear some one say. Very well; in that case you will be obliged to allow the crop to fully mature before harvesting it. You will secure your seed as well. It seems reasonable that, all things considered, where hay is scarce, it is better to make hay of the entire crop than grain and straw and then be obliged to either purchase hay or be short in roughage material. This is of somewhat more importance where the ordinary hay crops flourish only with difficulty, being thereby scarce and costly.

The Feeding Value.—When we compare oat hay and timothy we find that the former is superior, as seen in the following table:

| HAY | DRY MATERIAL | DIGESTIBLE NUTRIENTS IN 100 LBS. | | |
|--------------|-----------------|----------------------------------|---------------|-----|
| | | Protein | Carbohydrates | Fat |
| Oat Hay----- | 91.1 | 4.3 | 46.4 | 1.5 |
| Timothy----- | 86.6 | 2.8 | 43.4 | 1.4 |

While oat hay contains more dry matter and crude fiber, it is higher in digestible protein, an item of considerable importance. These facts suggest that oats may be grown to much greater extent than now as a partial solution to a scarcity of hay in Southern sections of the country.

Variety to Use.—We have in all nearly 150 varieties of oats, and it is quite impossible to say which one is best. The fact is there is no one best any more so than there is a best breed of cattle, or of sheep, or of swine. The variety best for me may not be best for you; the variety for the Southern farmer is never very desirable for the Northern farmer. A neighbor said to me a couple of years ago: “I am going to try the new variety of oats this year that is so extensively advertised.”

“For your entire crop?” I asked.

“Yes, certainly; if I use these new oats at all I can't bother with some other kind besides.”

I suggested that it might be well to do so. I told him that I had been trying each year in a small way several kinds of oats, and corn, and wheat, and peas, and other crops, and found considerable variation in the results. I suggested that it might be wise to use the kind he had always used, and which I knew was reasonably satisfactory, and try the new oats in a small way, an acre, perhaps. If the new variety proved at home under his soil and climatic conditions, then he could abandon the old kind that had been fairly true and faithful to him; he would from his acre trial plot have sufficient seed for his entire crop the next year. My neighbor followed this plan. The new variety was an utter failure. He has more faith in the old variety now. If he will select his seed with care, as he

does his live stock for breeding purposes, improvement will result to his satisfaction and profit.

If you are dissatisfied with the kind you are growing because of inferiority, and poor yields, you had better start over again, this time using one of the old and tried varieties that is at home in your section. Some of these are the following: For the West and North—Lincoln, American Banner, Early Dakota, Welcome, Seizure, Pringle's Progress, White Bonanza, Wideawake, Clydesdale and Monarch. For the Southern states—Virginia Turf, Virginia Gray, Red Rust Proof, Gray Winter and Beardless. When you once get a variety adapted to your conditions, help it out by selecting seed.

Improving the Variety.—If you set out to improve oats, have in mind only desirable features and do not make the mistake of extending your work in too many directions. A few important characteristics well established are more to be desired than an attempt with only indifferent results. A few features that should be included in every breeding operation are these:

1. Hardiness and freedom from rust. A rust-resisting variety would be superior for that feature alone, and would command favor in every direction.
2. Earliness. Oats are partial to cool and moist climatic conditions, hence the earlier they mature the more satisfactory are the results.
3. Strength of straw. A common trouble with oats where land is fertile is their tendency to "down." Keep this weakness in mind when breeding for improvement.
4. Heavier yield in grain. There is an open field in this direction.

Treating for Smut.—Smut is so common, so

widely scattered and so destructive and yet so easily prevented by simple remedies, there should be no hesitation in doing this work and in keeping it up year after year. Not long ago a prominent New York farmer, a friend and myself were walking in the country and came to a field of winter oats. They looked fine and promised to make a fine crop. "Do you know," our New York companion remarked, "it is wonderful what can be done by treating oats for smut."

"In what way?" I asked.

"In not only preventing it, but also in greatly increasing the yield and weight. I have only recently treated my oats, but I am sure it adds 10 per cent to the commercial value. A neighbor of mine didn't believe in doing this. Last year he borrowed my drill. In the drill was perhaps a bushel of seed left over from my seed oats. My seed had been treated and I told my neighbor to use them and then later compare with his own if treating seed was worth anything anyway. Well, gentlemen, that test completely convinced not only that neighbor, but several others as well, and now nearly all seed oats are treated in our neighborhood."

At maturing time, examine a few heads in the oat field. You are sure to be surprised at the number of diseased heads. I have often counted from 30 to 40 in every hundred affected with smut. This is a tremendous loss; and, just think of it, for a few cents per acre seed can be treated and the disease entirely eradicated. Smut ripens just at the time the plant is in the flower. Being loose and light, it is easily blown by the wind, thus leaving the heads bare of grain and black.

The most common way of treating seed oats

is to soak for 30 minutes in a solution of formalin containing 1 pound to 50 gallons of water. Formalin may be purchased at any drug store, and costs about 75 cents a pound. Still another way to use formalin is to take one-third as many ounces as you have bushels of seed oats to treat; mix an ounce in 3 gallons of water, or the whole quantity in water at rate of 3 gallons for every ounce of formalin. Each gallon of the solution will treat 1 bushel of oats. This is a good way to do this work: Spread the seed thinly upon the barn floor and sprinkle with the solution, being careful that all seeds are wet. Cover closely with blankets for a few hours and plant very soon after treatment. In drying the seed, spread thinly in the sun and frequently stir and air. Another method for preventing smut is to sprinkle the seed thoroughly with a solution of blue vitriol; to prepare use 1 pound to 10 gallons of water.

Oats and Peas for Forage.—Plow the land as for corn. Sow a bushel of Canada field peas to the acre and cover 4 inches deep. A few days later sow oats at the rate of 2 bushels to the acre. The delay in sowing the oats gives the peas a start, and brings the two crops along together. A more common practice is to mix Canada field peas and oats in proportion of 1 bushel of peas to 2 of oats, and sow with wheat drill. Both methods are good.

ORCHARD GRASS.—A very desirable perennial grass for hay. It grows 2 to 4 feet high and yields from 2 to 3 tons to the acre when grown alone. It has an abundant aftermath and shortly after being cut shows growth and greenness. It is quite at home in shade, and for this reason is quite suited for woods, orchards and pastures where many trees

abound. A good time to cut is when the grass is in bloom. If mowing is postponed the hay is inclined to be woody. Usually two cuttings may be obtained in one year and sometimes three. The grass grows in tufts and if grown alone not all the ground is covered. For this reason other grasses should be mixed with it, like timothy, clover and blue grass. The seed may be sown in the fall or spring, using 2 to 3 bushels to the acre. Sow broadcast and slightly cover with a harrow. Orchard grass starts quickly and may be pastured the first year. Its greatest merit lies in its abundance of forage, its early growth in the spring, and its defiance to drouth. The tramping by stock does it little injury. No mixture of permanent pastures or meadows is quite complete without some orchard grass seed.

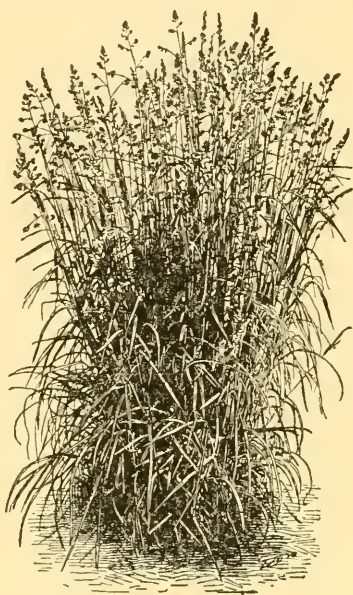

ORCHARD GRASS

A splendid mowing crop and a good pasture grass. It likes rather fertile, moist soils, and is not averse to shade. The best results are obtained when other grasses and clovers are mixed with it.

PEANUTS.—A valuable feeding stuff, good as food for man and beast, and good for the soil as an improver. For man, it furnishes protein and ash materials in considerable quantities, and for farm animals it is an extremely valuable balancing food to go with corn and other carbonaceous feeds during the growing season. As a soil improver it ranks

with all leguminous crops. If the grower fertilizes his peanut land abundantly with phosphorus, potassium and lime—for let it be known that peanuts relish lime in considerable quantities—his land ought to be more fertile and productive after each succeeding year. Peanut lands suffer, as a rule, from the depletion of the mineral elements. Of course a considerable quantity of these mineral elements enters into the growth of the kernel.

Now, as the peanut uses a considerable quantity of mineral materials, it follows that if good growth and productive yields are to be obtained, it is necessary to add such elements in the fertilizers. Peanut lands also lose considerable fertility and value through the constant washing during the winter season. This is not necessary, because some growing crops can follow peanuts so as to prevent the washing and the leaching of the soil. Crimson clover is a good winter crop. If difficulty is encountered in securing stands in sandy lands, a crop like rye is excellent for the winter season. Since a rotation of crops is as important in peanut growing as in any other line of special farming, it follows that it is not wise to grow peanuts on the same land every year. Follow rye, therefore, with some crop like cowpeas or some vegetable adding crop or even corn. Of these, cowpeas are, of course, the best.

Peanuts, while grown most extensively through Virginia, North Carolina and Tennessee, can be grown in most sections of the country. In fact, it may be said that peanuts will grow everywhere that Indian corn succeeds. A loamy soil of a sandy nature and light and porous, produces the most remunerative peanuts. However, practically any

kind of soil that is open and friable and that can be kept so, provided there is lime and mineral elements, will do for the crop. The objection to the clay soil lies in the staining of the pods. So far as yield and weight are concerned, the clay soils have given extremely good results. In fact, the peanuts on such soils are heavier than on sandy soils. The clay soils being colder and less active, do not permit as early planting as the sandy ones.

It has been mentioned that peanut soils require lime, and also phosphorus and potassium. Marl is often used and so are oyster shells. However, common limestone answers every purpose on the peanut farm. As a rule, 30 bushels of lime make a good application to the acre. Frequent and small applications are superior to infrequent and heavy applications of lime.

Anyone can prepare land for peanuts. Any preparation that will get the soil to a good depth of plow, and then thoroughly harrowed and pulverized to the depth of 4 or 5 inches, will provide good preparation. A common practice is to break the land with an ordinary turning plow as soon as possible in the spring, and then follow with the harrow and the roller until a suitable condition of the land is obtained. About 2 bushels of nuts in the pod are sufficient to furnish seed for an acre. In opening the pod for planting purposes, care and attention are necessary in order to avoid the breaking of the skin of the kernel, and also to select the more perfect kernels as they are shelled.

Harvesting Peanuts.—After frost run the point of a plow under the vines so as to cut the roots and then lift the vines with the adhering pods out of the soil and shake free from dirt. Lift out with a fork.

When wilted stack the vines loosely around a pole about 7 feet high, using some sticks under them, to keep them off the ground, and cap with hay or straw. If stacked in large stacks or too closely, they will heat, so this must be avoided. After about four weeks the nuts may be picked from the vines and stored where they will be dry and well aired.

PEARL MILLET.—See Millets.

PERENNIAL RYE GRASS.—A good hay crop, but not generally grown. If planted in the spring it grows abundantly, being ready to cut in



PERENNIAL RYE GRASS

Dry soils are disastrous to it, as are also stiff clays. It is most useful in mixtures with red top or orchard grass which increases in value as the rye decreases.

six or eight weeks. It is very succulent in character, but abhors dry weather. It is good in pasture and meadow mixtures and about 1 bushel of seed to the acre should be used. It fancies a fertile soil containing much lime and one moist and rich in vegetable matter. It abhors stiff clays. Where timothy does well, there is little or no occasion to use this grass.

POLISH WHEAT.—A wheat plant somewhat resembling rye in general appearance. It is rather tall,

the stems are smooth and more or less pithy within. It does not stool to any extent. It bears large heads that are loosely formed before ripening; these are bluish green in color. The grains are hard, yellowish to white in color, and are much larger than ordinary wheat. This wheat seems to be

best adapted to the arid districts, but calls for a rather fertile soil and a good deal of moisture at seeding time. Its use in this country is limited to the production of macaroni. It is not used for breadmaking.

POTATOES.—The successful production of a large crop of merchantable potatoes is, under existing conditions, largely dependent upon: (1) Suitable soil; (2) sufficient plant food; (3) good seed of desirable varieties; (4) proper culture; and (5) thorough spraying. Neglect on the part of the grower to supply any or all of these conditions inevitably lessens the resultant crop.

Soils best adapted to potato culture are those of well-drained, sandy or gravelly loam or clay loam composition, containing an abundance of humus and fairly retentive of moisture. Those that are not adapted to potato culture and which should not be used where possible to avoid it, are very heavy clay or very light, sandy soils. These should be avoided because of their poor mechanical texture. Other soils that should not be devoted to potato culture are those that are low or moist. These are not adapted to the crop, because on such soils the potato vine is almost sure to blight badly. Good air and soil drainage are essential to success, at least to the greatest degree of success.

A clover sod is generally considered especially desirable to turn under for a potato crop. This should be plowed in the fall unless the exposure of the soil is such as to cause undue washing by heavy fall and spring rains. Plow as deeply as the character of the soil will permit, say 6 to 8 or more inches. In the spring, preparatory to planting, fit the land as thoroughly as possible with

cutaway or spring-tooth and smoothing harrow. In lieu of clover sod, any land answering the above requirements that is in good tilth will give fairly satisfactory results. Thorough preparation should be the keynote of any soil.

Fertilization Necessary.—If the land is thought to be lacking in both humus and plant food, these deficiencies can be supplied by a good application of barnyard manure. This should be spread on the land after plowing in the fall and thoroughly incorporated with it in the spring fitting. An application of stable manure in the spring is not desirable, as this practice tends to produce scabby tubers. If well-rotted manure is available it may be used. Usually on all soils well supplied with humus, commercial fertilizers will serve the purpose much better than barnyard manures, as they may be applied in definite proportions to suit the needs of the plants.

Early potatoes require more liberal application of quick-acting fertilizers than do late ones. An application of 1,000 pounds of a commercial fertilizer containing nitrogen 5 per cent, phosphoric acid 8 per cent and potash 10 per cent, has been found to give good satisfaction with early potatoes on light soils. Much larger amounts than these are frequently used by truck growers near large cities. For late potatoes a less active fertilizer is needed, as the plants have more time in which to develop. In this case an application of 800 to 1,000 pounds commercial fertilizer containing nitrogen 2 to 3 per cent, phosphoric acid 6 to 8 per cent, and potash 8 to 10 per cent is considered sufficient. Each grower, however, must determine, in a large measure, the requirements of his own soil. Com-

bination manuring with commercial fertilizers and barnyard manures is frequently practiced to good advantage. An application of eight to ten cords of manure to the acre in the fall, followed with 500 to 600 pounds of a quick-acting commercial fertilizer when fitting the land or dropped in the furrow at

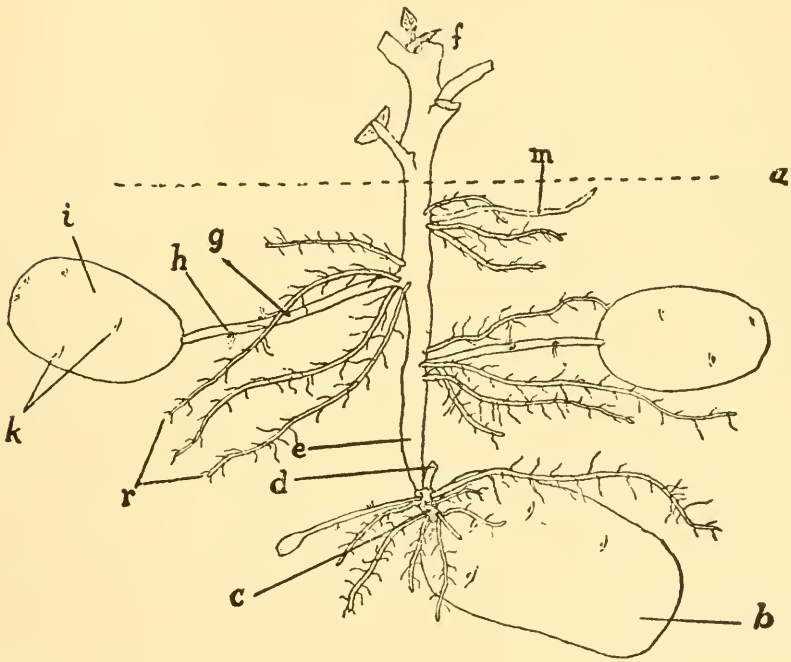

THE POTATO UNDERGROUND

Here are shown the tubers and root system of a potato plant. For best results a deeply stirred soil is desirable. The intertillage should not be so deep as to interfere with the root system below.

planting time, usually insures a thrifty growth of plants. Some prefer broadcasting.

Good Seed of Desirable Varieties.—As a rule, too little attention is paid by the average grower to the quality of the seed tubers or to the selection of desirable varieties. Seed potatoes kept at a uni-

formly low temperature of 33 to 40 degrees during the winter and not allowed to sprout in early spring will give stronger and more vigorous plants than those kept under less favorable conditions, because they will not be wilted nor will their stored energy have been dissipated by premature sprouting.

Another governing factor in the vigor of the plant is that of the size of seed tuber used. Generally speaking, the use of one-eye seed pieces will not give as good results as medium-sized tubers halved or planted whole. There are some exceptions, however, to this rule, as in the case of varieties having numerous eyes, each of which is capable of producing several sprouts. With such varieties, a one or two-eye piece will give better satisfaction than a whole or half tuber. The selection of vigorous, prolific varieties of good quality materially aids in the production of a profitable potato crop. A good commercial variety of potato for most markets should have white or flesh-colored skin, be smooth and regular, roundish-oblong or kidney-shaped, shallow eyes and mealy when cooked.

Seed Bed and Cultivation.—Under no circumstances should the potatoes be planted until the seed bed has been thoroughly fined and compacted. Go over it with an ordinary harrow until every clod is broken up and the entire portion turned by the plow thoroughly compacted. Plant in rows. Some people check, but in most potato-growing districts this is not necessary. If the soil is naturally fertile and free from weeds, the potato crop can be kept clean without checking, and, as a rule, larger crops produced. Cultivating potatoes is of very great importance. Not only must weeds be kept

out of the field, but cultivation must be frequent, so as to conserve moisture. Keep it up just as long as possible, being careful not to disturb the roots, particularly after the potatoes begin to set. If the potatoes have been planted in long rows, very little hand culture is necessary. It will be advisable to go over the field at least once with the hoe while the plants are young, so as to clean out all weeds that are of any considerable size. By

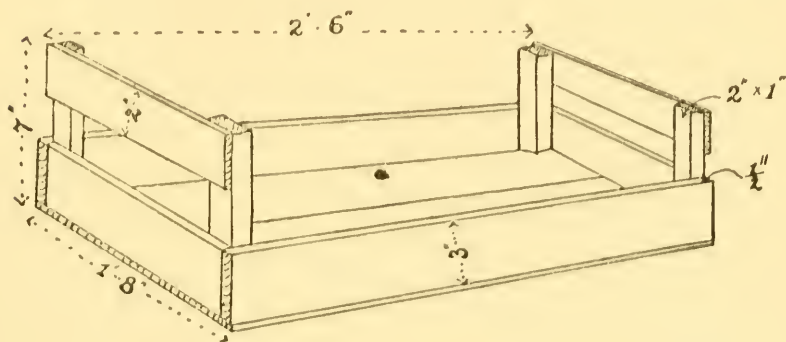

POTATO TRAY

A useful potato tray for the storage and sprouting of seed beds. The dimensions given here can be readily followed in making this tray.

that time, however, there ought to be but few weeds in the field.

Kill Off the Bugs.—If potato bugs attack the vines, spray with paris green. If a cheap spraying pump is not at hand, mix one teaspoonful of paris green with three gallons of water and for a sprinkler use a bunch of timothy heads. See that all the potato tops are coated with green, then the bugs will not do much damage. If a heavy rain comes soon after applying the spray, repeat. After the potatoes have been half raised it pays to go to

a good deal of trouble to prevent their being destroyed by bugs.

Potato Blight.—Late blight or rust is caused by a fungus, a kind of mildew, which is carried through the winter in the seed. Where such infected potatoes are planted the fungus develops in the potato shoots and finally causes the blight of the leaves, providing weather conditions are at all favorable. The germs or spores are produced in enormous numbers on these blighting leaves and by these the infection is spread to neighboring plants. Many of the spores fall to the ground also, and invading the tubers, cause the rot. Spraying with bordeaux kills the spores, and so prevents both the blight of the leaves and the rot of the tubers.

Selecting Seed Potatoes.—In the selection of seed potatoes there is but one safe rule to follow. Procure it from that place where it is the most perfect and healthy, where the yield under favorable conditions is the largest, and where the character of the soil and the conditions of climate are similar to your own. The development of the potato as to quality and productiveness is more due to proper care in selection for seed purposes than to all other causes combined. This care is a simple matter, so simple that its importance is rarely understood or appreciated. The usual one of selecting the most desirable tubers from the bin at the time of planting is but the first step in the line of improvement, and that step often a mistaken one, as the ones chosen may be the only ones to be found in a hill, and the ones selected may represent as many hills as there are specimens selected.

The proper method to pursue is to go over the field at the time of harvest, select vines that are

strong and stocky, not long or straggling. Carefully take up with a fork, and if the potatoes in that hill or from one given vine are all of a uniform shape and of a desired size, such are the proper ones to select for stock, and none others. One of the laws of reproduction is that "like produces like," and where there is but one well-formed potato in a hill or from one vine, the offspring will too closely resemble the parent. We are familiar with this practice, and know the results are of far greater importance than we have stated, that the annual crop is more than double than where ordinary methods of taking best-looking specimens from the bin are followed and the quality is better.

Digging and Storing.—Potatoes should never be stored immediately after digging, but should be allowed to dry. If picked up directly after digging, unless taken to market at once for shipment or to the starch factory, they should be placed in small, long piles not to exceed four or five bushels and left for a week or ten days. This will give them a good airing and will give the surplus water in them a chance to evaporate, or, as some farmers please to call it, allow them to sweat. If this moisture remains with the potatoes, it will collect in drops on the surface of tubers in the middle of a large bin full and will pick and foster rot germs and destroy many bushels before the owner is aware. Never dig potatoes on a damp, foggy day or a day when a soft drizzling rain is falling. The moisture will soak the ground, make it stick tight to the potatoes and not only make the produce unsightly but prove hurtful.

Barrels and Bins for Storage.—Barrels are no doubt the most convenient, but as these are not

always to be had, bins about 4 or 5 feet wide, of convenient length, and provided with a floor a few inches above the ground, will serve the purpose very well. The bins should not be filled to exceed 6 feet deep. Have the floor raised rather than on the ground, to allow a free circulation of cool air and to keep off possible moisture in the ground.

If kept in the cellar put the seed potatoes in barrels and set the barrels on sticks so as to be free from the ground to allow cool air to circulate around the barrels and to prevent mold from collecting on the head and thus making it moist. Use tight barrels and shut out the air all you can. Keep as cool as possible, but, of course, do not allow to freeze—the best authorities say 35 degrees is the best temperature for seed—and keep the temperature as uniform as you can. Here is where the cold storage building comes in handy.

Seed Potatoes Out of Doors.—At digging time put the potatoes into the cellar and leave them there until cold weather sets in. Then clear a place on the north side of a barn or hedge and on a cold morning, when cloudy and near freezing, bring out the potatoes. Pile them on top of the ground, not in trenches, but in long narrow piles, and covered with a thick layer of straw, beginning at the base and topping out with a layer a forkful thick. This is covered with a layer of earth 4 inches thick and then left until heavier frosts come, but not hard enough to injure the tubers. Another layer of straw is now added and another layer of earth 10 to 12 inches thick and steep enough to shed water well. Then sometime in February or March, when the earth begins to warm up, the snow is cleaned off and a thick covering of straw or mulching

placed over this, the object being to keep the frost in as long as possible.

Controlling Potato Pests.—Late leaf blight is by far the most destructive, persistent and troublesome disease that affects potatoes. It is caused by a fungus which, under favorable conditions, appears as a delicate white mildew, hence the name sometimes applied, downy mildew. In some seasons it works so rapidly as to completely destroy the foliage of an entire crop within a few days of its first appearance. It attacks the leaves and stems and frequently extends to the tubers, the rotting of which follows quickly upon the decay of the tops. The decay in the tubers is not always proportionate to the decay in the vines, but the relation between these is usually close, hence the wisdom of promptly applying remedial and even preventive measures. The treatment is the same in kind as for early blight, that is, spraying with bordeaux. As the beetles come at the same time as blight, a properly prepared spray will answer for both.

Little good will result from spraying after injury from the disease has become in any considerable degree apparent. Spraying should begin, therefore, even before the blight has appeared and usually as soon as the plants are 6 to 10 inches high. The number of sprayings will run all the way from one to six or seven, according to the conditions, especially those that relate to weather. Ordinarily from three to four careful sprayings will suffice, but not in all instances. When but three are given, the first should be deferred until there is danger of harm from the flea or the Colorado beetle. Ordinarily from 10 to 15 days are allowed to elapse between the sprayings, but, in some in-

stances, a longer period is allowed. During what may be termed an epidemic of blight, it may be necessary to spray every seven days. Light applications and frequent are more effective than heavy applications and less frequent.

To prepare bordeaux, slake 4 pounds of good, fresh quicklime in 10 gallons of water. Dissolve 5 pounds of copper sulphate, that is, blue vitriol, sometimes called bluestone, also, in 10 gallons of water, preferably hot, to hasten the dissolving process. If the copper sulphate is suspended near the top of the water in a sack, the results will be more satisfactory. When the mixture is wanted, pour the two solutions thus obtained slowly into a barrel containing 30 gallons of water, vigorously stirring during the pouring process. The mixture will soon lose strength, hence the necessity for using it fresh. If flea or potato beetles are giving trouble, about 1 ounce of paris green of good quality should be added to each 10 gallons of the mixture.

On small areas compressed air sprayers which hold not more than 5 gallons of the mixture may be used. For larger areas knapsack sprayers will answer. For still larger areas a barrel spray pump mounted on a light wagon or two-wheeled cart, drawn by one horse, may be necessary. When in use, one man rides, drives and pumps, and two men walk and spray. The pump has two leads of hose, each about 15 feet long, and provided with double nozzles. Several rows are thus sprayed at one time. For still larger fields, geared pumps operated by horse power have been found entirely practical. Two or three hours should elapse after spraying before rain falls. It is a matter of prime importance that the vines shall be well covered with the

solution before the blight fostering weather arrives.

POULARD WHEAT.—A macaroni and pastemaking wheat grown in this country in an experimental way only. In the regions surrounding the Black and Mediterranean seas the greater part of this kind of wheat is grown. Sometimes it is called English wheat, but it is never grown in that country. It is closely allied to the durum group. It is satisfied with light rainfall and has great ability to withstand drouth and heat. It calls for a fairly rich soil.

PUMPKINS—In the old days, pumpkins were a popular stock food. Since farm machines for planting, cultivating and harvesting have come into use, pumpkin growing in the cornfields has fallen into disfavor and disuse. If pumpkins are grown at all now, they are usually grown in a patch off to themselves. This custom has not become universal by any means, as in many sections field pumpkins in the cornfield are frequently seen, especially of those who have profited through large quantities of pumpkins as a fall feed for cattle and hogs. Seed is still mixed with the seed corn and dropped in the planter.

The objection to this method lies in the trouble in cultivating the field later. Pumpkin growers have in many instances resorted to the old jobber planter for putting in the pumpkin seeds when the corn has become anywhere from 4 inches to 2 feet in height. If the corn harvesters are used, it naturally follows that great quantities of pumpkins will be destroyed. When grown alone, a sandy loam is best. This same kind of preparation is necessary as for corn. When planted alone it is

advisable to plant the pumpkins something like 8 by 8 feet. From 3 to 4 pounds of seed will be necessary to the acre. Of course, drilled planting can be resorted to. If hill planting is adopted, three or four plants should be left to the hill. Constant cultivation pays in pumpkin growing as it pays in corn and other kinds of crops. Freezing is hurtful to pumpkins and, therefore, they should be gathered and stored before cold weather arrives. If the stems be brushed off or the pumpkins bruised they will quickly decay. A dry, moderately warm pit or cellar is desirable for storage. A barn or stable can be used, but if the weather is cold it is best to cover with corn stalks or hay in order to protect from cold weather as long as possible. Anywhere from 20 to 40 tons of pumpkins may be secured to the acre. There is a place on the farm for pumpkins, as they are relished by both swine and cattle in the fall. They may be fed raw or cooked and are good for hogs up to the final stages of fattening.

RAPE.—English farmers have for generations made extensive use of Dwarf Essex forage rape as a stock food. This plant may be described as a rutabaga run to head. The seed is sown broadcast, from April to July, or sown in drills, like rutabaga turnips, and cultivated without thinning. The large, numerous, succulent leaves are generally appreciated by sheep most of all, then by swine and cattle. Rape is fed off by turning stock directly into the field, so there is no expense for harvesting. As indicated above, it may be sown any time from early spring until midsummer, and furnishes food from about eight weeks after sowing until it is consumed.

Rape seeds may be sown at different seasons. The time of seeding will largely depend on the time of year the crop is wanted for feeding. It may be sown in early spring or as late as July, and good results will be obtained providing the season is



RAPE PLANT

This plant stores the nutriment in its leaves and is most excellent for grazing purposes, especially for hogs and sheep. It may be planted in the spring or the fall. When at its best it is almost a complete food.

moist enough to germinate the seed. When sown in early spring, it will usually be ready for pasturing in about eight weeks. Some have got very large yields by cutting the crop rather than pasturing it. If you cut it, do not cut too close to the ground, for if this is done the plants oftentimes fail to produce a second crop. If cut 4 or 5 inches above the ground as many as three crops a season can be had from one seeding. When seeded in early spring it may either be sown in drills or broadcast. Usually the best results are obtained when drilled in rows from 2 to 2½ feet apart, just wide enough to allow a cultivator to pass between the rows. If cultivated two or three times the weeds are kept down and the rape will make a much more rapid growth. If drilled, about 2 pounds of seed an acre should be used, but if broadcasted use double that amount. Never sow anything but the Dwarf Essex variety, as it is the best. Sometimes farmers have been deceived in buying rape seed, and got a kind that did not make much growth and blossomed early.

Rape will grow and do very well on a variety of soils, but the largest yields and most satisfactory results are obtained when it is produced on a rich soil containing a liberal amount of vegetable matter. When sown alone and in spring more rape will be grown than is possible by any other method, as oftentimes three crops a season can be obtained by such a practice. Many farmers have succeeded in getting two crops off the same ground by sowing rape seed with oats or in the cornfield at time of last cultivation. Such a practice is frequently followed by good results, but if the season be very dry, the rape may not make much growth. It is

well worth any man's time to experiment a little along these lines, for in most instances he will be well paid for his trouble.

When Sown with Oats the most common practice is to mix the rape seed in the seed box with oats and drill both at the same time. About $1\frac{1}{2}$ pounds of seed to the acre should be used. On very rich soil it might not be advisable to use more than 1 pound of seed to the acre. The rape plant will make a fair growth until the oat crop is harvested, when it will grow very rapidly and furnish an abundance of good pasture for sheep, hogs or young cattle. When grown in the cornfield seed should be sown just before the last cultivation. Sow about $2\frac{1}{2}$ pounds of seed to an acre. This method is occasionally more satisfactory than to sow with oats, but either method may prove very profitable.

Rape is not like clover, cowpeas, or soja beans in being able to obtain its nitrogen from the air, and consequently is not so valuable as a fertilizer. The roots of the rape plant go down into the sub-soil and in this way they bring fertility to the surface soil. Some grow rape for this purpose alone, but most people grow it for its value as a forage crop. This plant is an excellent food for sheep, swine, beef cattle, and when carefully fed to dairy cows good results can be obtained. Those who have never tried rape should sow a little and be convinced that it is one of the most useful forage plants the farmers can grow.

RED CLOVER.—One of our best forage plants and used for pasture, hay and soil renovation. It grows in all parts of the country. Clay loam soils overlying a mild clay are best for this crop. How-

ever, any soil not too loose is satisfactory. Clover will grow on land that is not rich, but on poor soils liberal applications of potassium and phosphorus should be given. The crop is sown usually with a nurse crop and is most popular in rotations with corn, wheat and oats. It precedes the corn and is seeded in the spring either in oat land or the wheat land. In localities abundantly supplied



COMMON RED CLOVER

The most important member of the clovers grown in most sections of the country. Alfalfa in the West and the cowpea in the South somewhat displace it. No farm is complete without some legume. Every rotation should contain one or more of the clovers.

with moisture and favored with mild winters it is practical to sow clover in the late summer and early autumn months.

The seed may be sown broadcast by hand or by means of a hand seeder or with an attachment to the grain drill. Sometimes it is fixed with the grain seed and sowed along with it, but this kind of sowing is not to be commended.

There is too great irregularity in the seeding. A better stand is usually obtained if the seed is slightly covered. This usually oc-

curs when the seed drops in the drill rows, since the first rain brings the soil sufficiently over the seed, securing the necessary protection for it. When seeded in spring wheat, the best time is after a

frost when the soil is in a honeycomb condition. The seed drops in the cracks and the heaving and thawing cover sufficiently to insure germination and foothold for the roots. From 5 to 10 pounds of seed are usually sown to the acre; the latter quantity being preferable.

It is not best to pasture off the clover the same year it is sown. The exception to this is when wheat stubble is pastured by hogs. Of course, the clover has, as a rule, reached a good height by the time the wheat fields are available for pastures, and hogs do not give an extremely close cropping at this time, so this method is not to be condemned. Indeed farmers who grow wheat, hogs and clover resort to the plan and so universally is it practiced it is only during exceptional seasons and under exceptional circumstances that injury is done to the crop. In any case the crop should not be close cropped in the fall. If clover goes into winter unprotected, it is more liable to be injured.

Clover may be included in any and all grass seeding. It does not remain in permanent pastures, because it is a short-lived plant. Its quick-growing habit during the first year blends well with the slower growing habit of timothy and other grasses. By the second year the clover disappears and then timothy, red top or other grasses included in the mixture are ready to start at their best. As the clover dies the nitrogen stored in its roots becomes available for the other grass plants and the decaying roots themselves leave a wealth of humus and plant food in the soil that will be seen during subsequent years, even long after the pasture has been succeeded by another crop.

Growing Clover for Seed.—A much larger yield

of clover seed may be obtained, and seed of better quality, if the first crop of red clover is cut early, as it will do for hay. This would be when one-third is in full bloom. The mistake is often made of commencing at that stage of growth and continuing over some weeks, so that most of the cutting is much too late. The second growth will come strong from the large root system and will bloom when bumblebees are most plentiful. When ready to cut for either hay or seed, the mower will clip off the heads with a foot or two of straw. This makes good hay, leaving the coarse stalk on the ground. Or it is easily threshed, since there is no more straw than the common red clover has.

Before cutting the seed one should examine the heads to see if they are well filled. Hold a head between thumb and finger and shave off one side till seeds are exposed. It is easy to count the empty cups. In pinching heads, one will find those well filled are hard and firm, empty heads chaffy. It is well to examine, since there is great variation.

In cutting the red clover for seed use a buncher. But the large clover with its long, bent-down stubble will not pull the clover off the buncher. In this case cut it dewy mornings and rake it into windrows while slightly damp. If heavy rains fall on the cut clover it may need turning. This do with a four or six-pronged fork without parting it more than necessary. Turn a bunch much as you would a pancake. If the rain is not heavy it will usually dry out without turning.

Thresh in the field, hauling to machine on tight-bottomed hay ladders. The nicest way is to have these on sleds instead of wagons. Do not tramp

it on the load, but leave it fluffy and open. Great care should be taken that the straw is dry. Just a little toughness will waste seed surprisingly. It should hull out by rubbing in the hand and the chaff crush dry. If a little tough, one may waste much seed. The best time is when a slight wind is in the south and a bright sun is shining.

Second Growth Clover.—Fall treatment of a clover field is very often neglected. The second crop may be cut for hay, grown for seed or pastured. There is no reason why a profitable second crop cannot be secured, but the use to be made of this is a question with many growers and a matter of more or less dispute.

If intended for seed, the first crop should be cut early when it is just beginning to bloom. When this is done the second crop will have more vigor and produce more seed. It is always best to cut before full bloom has been reached, because then it contains the largest per cent of protein, has less crude fiber and is more valuable for feed. The Maine experiment station reports that when heads are first forming, clover has 23 per cent of protein; heads formed, 18 per cent; full bloom, 14 per cent; some heads dead, 13 per cent, and all heads dead, 12 per cent. So when cut early the second growth is not only better, but the feeding value is greater.

For seed, the second crop should grow until the first heads are ripe and begin to shell. If the later heads contain the most and largest seed, they should be ripened in preference. It should be cured in small cocks and these turned over when dry on top. The seed may be threshed out with a flail and fanned, or the heads themselves sown for home use. As insects are very troublesome, it is seldom

profitable to try to mature the seed. If seed is to be grown, however, the mammoth variety should be selected, as this is a later and hardier variety than the medium red. Only one crop of the mammoth can be grown in a season, and if seed is sought, it should be pastured or mowed early in the season to delay its maturity until later in the summer, when it will have a larger yield.

If it can be avoided, it is not advisable to pasture the clover field, although it makes excellent feed. The tramping of the stock has a tendency to make the soil more compact and heavy. When it is pastured, the roots do not penetrate the soil so deeply, and consequently is not quite beneficial as a soil improver. Everything being considered, it is about as well to let the second crop go back to the soil if it is not harvested for hay, when it can go back in the form of barnyard manure.

In the fall, before the weeds have gone to seed, it should be cut with a mowing machine, not very close to the ground, however. This serves as a mulch to protect the soil through the winter, and at the same time adds rich humus. The growth the following year will be greater and probably enough to offset the loss from its going back to the soil.

RED TOP.—An upright perennial frequently mixed with timothy and other grasses for hay. In New England, New York and Pennsylvania red top is an old standby. In the South and West it is not so well known. In some instances red top is used as the only grass in the crop. Some markets consider red top a weed and the hay suffers accordingly so far as price goes. Red top is more nutritious than timothy, and any prejudice against it is unwarranted. The crop does splen-

didly in low, moist and swampy lands, and is good for either meadows or pastures. It may be flooded even for some time without suffering to any extent. It seems to do fairly well on acid soils; indeed, some say it does its best on sour lands. It is no better adapted for short rotations than timothy, as it requires at least two years to get a firm foothold. Its creeping nature in growing makes it good for bottom lands. The quantity of seed will depend upon how clean the seed is in the first place. A pound or two of thoroughly cleaned seed is all that is required. With uncleaned seed, or as ordinarily used, from 15 to 20 pounds will be necessary to the acre. It goes very well with timothy, orchard grass and any of the clovers. Its special favor to alsike is explained by the fact that alsike will grow in slightly acid soils where common clover will not. Seeding can be done either in the fall or spring. A small amount of red top with the usual grass mixture will not be amiss for most meadow and pasture lands.

RESCUE GRASS.—This grass, sometimes known as Australian Brome, grows from 1 to 2 feet high and resembles chess or cheat in appearance. It is an annual and reseeds itself. In the South it is used as a winter grazing grass. The



RED TOP

A perennial grass. It grows 2 to 3 feet high, with interlacing roots that form a dense sod. It stands tramping about as well as any grass. In some places it is more popular than timothy.

custom is to let it reseed itself each spring. If this is not done it soon runs out. When cut for hay, from 1 to 2 tons an acre are produced.

RICE.—A grass plant grown principally for human food. The crop is most largely grown in Louisiana and Texas, but the Carolinas and Georgia have at different times grown considerable quantities of this crop. The three main varieties cultivated in this country are the Japan, the Honduras and the Carolina. The Japan varieties have short oval berries, but the plants differ in habits of growth, days of maturity, and other physical features. The Honduras rice is large in size, has a rich kernel and yields heavily. The same may be said of the Carolina varieties. The Japan varieties lead in milling qualities. Red rice differs from the varieties just named. The grains are red or streaked with red. It is a very hardy variety and noted for its vigor. On account of the demand for white rice, this kind is not in favor in this country, although in other countries it is much used. Wild rice is a wild plant here and is not cultivated. It is found in places where shallow water abounds. Its use as a feed is very limited. It grows in the low alluvial lands along the rivers in Louisiana and Texas and in the bordering reclaimed swamps and tight water lands, including all the territory most given to rice.

The soil for rice must be rich—a thick loam is preferred. Previous to planting time, the most thorough kind of preparation is necessary. The soil must be firm and compact and possessed of much water. The clay types are very good, if not the best. Good drainage is desirable because this permits of early planting and a good soil prepara-

tion. The planting season runs from the middle of March to the middle of June. From 2 to 3 bushels are usually seeded to the acre. The rice seeder is often used, but most generally the seed is scattered broadcast. It is then harrowed so as to give it a reasonable amount of covering.

After planting, water is turned on the land so as to give it a thorough soaking and then withdrawn until germination has resulted. During rainy seasons and in moist lands, an application of water is not necessary. When the rice attains a height of 6 or 8 inches, the water is turned on. As the rice plants grow, the depth of water is increased. This keeps the weeds down and is just what the rice plant likes. The water is withdrawn sometimes previous to harvesting, to allow the soil to become thoroughly dry that the harvesting machines may be drawn easily over the land. When the straw begins to turn yellow, it is ready for cutting. If machinery cannot be used, the sickle is used. After being cut the rice is bound into sheaves and laid on the stubbles to dry. It is later shocked as in the case of wheat. The next operation is threshing, which is usually by machine just as with other cereals. The yield varies from 20 to 40 bushels to the acre.

On the whole, appliances are becoming more and more available so that farm hulling now has become a sort of established rule. The rice mills are complicated affairs. Not only must the grain be taken from the straw, but the light grains must be separated from the heavy; the weeds must be removed, the hulls separated, and the grain must be polished and graded and placed in sacks ready for shipment to market. Rice is usually graded as



THRESHING RICE

whole rice or heads; scant heads or straits; broken rice or screenings; and brewer's rice. This last is used in manufacturing beer.

The most serious obstacle to rice growing are weeds. Wild rice and red rice are both weeds in the regular rice field. If these get into the cultivated varieties they reduce the value of the crop. To avoid this trouble, it is necessary that only clean seed, positively free from red rice, be used. The rice grain after leaving the mill is graded, the better grains being used for human consumption. A by-product from the preparation of rice is known as rice meal and has considerable value as a stock feed. The rice hulls have little feeding value. In the past, they have been very greatly used as an adulterant in many kinds of cattle feeds. Adding rice hulls to these feeds now is a fraud and in most states is not permitted. Rice straw is used similarly with wheat straw.

RUTABAGAS.—As a winter food for live stock rutabagas have a wide range of adaptation. Like rape, this plant is found at its best where the weather is moist and cool. The crop should always be made a cleaning crop, save when the seed is sown broadcast. It may, therefore, with much propriety come after a succession of grain crops when the land has become weedy through thus growing these crops upon it, as it assuredly will become in time. Turnips will grow nicely in overturned sod lands when the sod is not too fresh and dense, but such lands are usually wanted for cereals because of their clean condition. A grain crop should follow the rutabaga crop, and because of the clean condition of the land, it would be well to sow grass seeds or clover seeds, or both, with the grain.

Rutabagas are partial to a deep, moist loam soil, with enough of sand in it to keep it friable. The seed may be sown with a hand drill such as is used in a garden when only a small quantity is to be sown, but when a large area is to be sown, a drill made for the purpose of sowing field seeds is commonly used. It is drawn with one horse, sows two rows of seed at a time, and a roller attached firms the earth over the seed. But when the weather is dry and the soil is not liable to blow, it will be advantageous to use the heavy field roller after the seed has been sown. From 2 to 4 pounds of seed are sown to the acre, according to the more or less favorable conditions of the soil and weather.

When sown in drills, the horse cultivation should begin as soon as the young plants can be distinctly traced in the line of the row. The cultivation ought to be deeper at first than later, and close to the rows, but not so close as to disturb the young plants. If, at the same time, the undisturbed portion of the soil is disturbed with the hoe, but without cutting out any of the plants, the weeds can never again become so troublesome along the line of the row. The cultivation given should be frequent and it ought to be continued as long as it can be done without breaking off any considerable proportion of the leaves of the rutabagas.

When the plants have produced four or five leaves, or when they are 3 or 4 inches high, the thinning should be done and with much dispatch. The workman stands facing the row, and with a forward and backward movement of the hoe strikes out the plants that are to be removed. The distance between the plants may be varied from 6 to

12 inches, but it is not common to thin the plants to a greater distance than, say, 9 to 10 inches; and they should be gone over a second time with the hand hoe, to perfect the thinning and also the destruction of the weeds. When rutabagas are broadcasted they are not given any cultivation.

RYE.—Rye will grow much better on rich land than on land that is poor. Nevertheless, it is grown chiefly on land that is sandy in texture and that is low in fertility. It is so grown because other cereals cannot be grown with equal success on such soils; but there are wide areas in many states well adapted to its growth and on these it is not grown. The habit of growth in rye enables it to gather food in soils where other cereals would fail.

The ground is prepared for rye as for other crops, that is, by plowing it to a reasonable depth. It is not necessary to plow so deeply as for some other crops, especially on sandy soils. Of course, the longer the ground is plowed before the land is sown, and the more frequently the soil is stirred the better will be the conditions for the rye, as the ground will then be cleaner and moister than it would otherwise be. In certain areas, however, especially of the prairie, rye is put in with the grain drill without plowing the land at all. The seed is drilled in among the stubbles and on such soils good crops are frequently grown. This method of sowing is best adapted to cold areas. The benefit comes largely from the protection which the stubbles afford to the young rye plants when driving winds are sweeping over the country in winter.

Rye is put into the soil like other cereals, being sown sometimes by hand, but more frequently and

more properly with the drill. It may be put in under dry conditions more deeply than wheat, as the young sprouts of rye can better endure conditions of privation than wheat. The amount of seed sown is usually from 6 to 8 pecks; more on poor than on rich soil. It should be sown even more thickly than other grain, as it has less power to stool.

Varieties.—There are two varieties of rye. One of these is known as winter and the other as spring rye. The winter variety chiefly is grown. The spring variety does not usually yield so well as the other. The best time for sowing winter rye can only be stated in a general way, as the time will vary with the locality. It ought to be sown so early that it will make enough of top to protect itself in winter and yet not early enough to be injured with the leaf rust that sometimes overtakes early sown rye. In the Northern states, the best time to sow winter rye is usually from the first to the middle of September. Going southward, the time of sowing will be later.

Spring rye cannot be sown too early providing the land is in proper condition to receive the seed. If winter rye is sown so late that the plants do not have time to make a reasonable growth before winter, in cold climates, the crop may be greatly injured, but where the snowfall is reasonably sure, late sowing will be more safe.

The rye crop is harvested like any other cereal. At the present time it is usually cut with the grain harvester. Owing to the stiff character of the straw it has the great advantage over other cereals that it seldom falls down. It is also ripe one or two weeks ahead of winter wheat, and, therefore, the harvesting does not interfere with the harvesting

of other cereals. Moreover, when grass or clover seeds are sown along with the rye, its early removal lets in the sunlight and is so far favorable to their growth. If the rye cannot be harvested at once when ripe, the loss from shelling is much less than with other cereals. The yields are usually moderate, as the crop is commonly sown on the poorest soil of the farm. They run, in many instances, about 15 to 18 bushels, though under favorable condition, more than 30 bushels per acre may be grown.

Rye weighs 56 pounds per bushel, and, therefore, is nearly as heavy as wheat. It is a valuable food for horses, milch cows, cattle that are being fattened, swine and sheep, when it is properly fed, but there is prejudice in the minds of many against feeding it, because of some evils that have resulted therefrom. It is true that ergot is found in rye occasionally, and when it is thus present in any considerable quantity it is also true that when fed heavily it will produce abortion in pregnant animals. The proper way to feed it when possible is to feed a small quantity and in combination with other feeding stuffs.

Winter Rye for Pasture.—None of the small cereals will compare with rye in providing pasture. Its strong points here include the following: It may be sown almost at any season of the year; good pasture may be obtained from the one sowing; a stand of grass may be obtained while it is being grazed, and it may usually be followed by another crop the same season.

If rye is to furnish good pasture in the autumn

it must be sown early; in the Northern states as early as August. It must then be grazed somewhat closely, for if allowed to grow too rank the head may form, which would destroy its power to grow in the spring. But a more important reason for grazing it closely is found in the tendency in the grazing to rust when it becomes of rank growth. While the weather is still warm cropping it down prevents it from rusting. It may thus be made to produce a large amount of grazing in the autumn, but when it does, the grazing furnished in the spring is less than that obtained from rye under similar conditions of growth, but sown later and not pastured. In the spring grazing is furnished earlier by rye than by any other plants used as pasture. The duration of the grazing depends somewhat upon the closeness of the cropping, but usually it does not continue good more than five to six weeks. By that time, however, other grazing is abundant as a rule.

Securing a Stand of Grass.—If rye is sown in the autumn and timothy or red top, or both, are sown along with it, these plants will root in the autumn and will not only be ready to furnish grazing along with the rye in the spring, but they will continue to grow and furnish grazing indefinitely. Another way is to defer sowing the seeds to the early spring, and then to sow such clovers and grasses as flourish in the locality and cover them with the harrow. Under proper conditions the harrowing will help the rye. There may be soils on which the early grazing of the rye would injure the growth of the grasses. On other soils, however, such grazing will be helpful to them, rather than harmful. Where this method succeeds it enables the farmer to get

pasture quickly when this may be necessary. When rye is sown in the autumn for pasture, it is usually sown after some other crop has been grown for the season on the same land. Thus, it may come after any of the other cereals. When grazed down in the spring there is still time to follow it with other crops. These include field roots, rape, millet and cowpeas. Excellent crops of these are frequently grown after rye pastures.

All kinds of quadrupeds kept on the farm may be grazed on rye. Its highest use probably is found in grazing ewes in the early spring that are nursing their lambs, or in grazing weaned lambs in the autumn in the absence of better grazing. Under some conditions it is a great aid in furnishing pasture to swine. However, it must be pastured with caution by dairy cows, or an unpleasant odor may be given to the milk. Early succulent rye is excellent for the production of milk. Such grazing is not much used in growing beef as it is usually too limited in supply.

RYE GRASS.—See Italian Rye Grass.

SANFOIN.—A vigorous growing plant, both branched and spreading. Its flowers are numerous and of a showy red color. It will frequently produce two or more cuttings of hay and several cuttings of soiling feed in a single season. It is seldom advisable to seek two crops of seed in one season, since the first crop does not yield nearly so well as the second. It is better practice to cut the first crop for hay, to use it as soiling food, or to pasture it, just as is done in growing common red clover seed. This plant will retain its hold upon the soil for several years. But other grasses are much prone

to crowd it out as it becomes older. In some instances it is only grown for one or two seasons, but usually the seed is too costly to admit of any extended use.

In the rough form from 4 to 5 bushels of seed to the acre must be used. When harvesting the seed great care must be exercised in handling the crop, or much of the seed will be lost. It should not be handled in the heat of the day; and when being made into hay the same care is necessary, or many of the leaves will be lost. Much care must also be given the seed, or it will heat and spoil. Inattention in this matter is largely responsible for the many failures to secure a good stand of plants. But it also seems to be true that the seed loses its germinating power more quickly than the seed of any other legume. Sanfoin, like clover, is very beneficial to the soils in which it is grown.

SCARLET CLOVER.—See Crimson Clover.

SHEEP'S FESCUE.—A perennial bunch grass much relished as herbage by sheep. It grows on thin soils and never becomes very tall. About 10 inches is its usual height, though when specially favored it may grow twice as tall. It is particularly suited for culture on the lighter, drier soils of a sandy nature where other grasses will not thrive. From 2 to 3 bushels of seed are required to the acre. Its light nature and slight growth put it out of the hay classes. Its chief value is as pasture in the drier regions where the soils are poor and the moisture too little to make an abundant growth.

SORGHUM.—A plant, somewhat resembling Indian corn in habit of growth and appearance. It

is used in the production of molasses and sugar and as a forage plant. Some varieties of sorghum contain more sugar properties than others. They fall into two classes—the saccharine and the non-saccharine varieties. This plant will grow anywhere that Indian corn will grow and will do very well on poor soils and in the drouth regions. While it is used to some extent in making syrup, difficulty has up to the present been experienced in getting profitable amounts of crystallized sugar from it. When grown for its molasses properties, good soils are practically indispensable. Either hills or drills may be used. The rows should be $3\frac{1}{2}$ to 4 feet apart, and if planted in hills, a similar distance in the row. The custom is to plant from 1 to 2 dozen seeds in each hill and to cover these about 2 inches deep.

If the soil is light and dry a little greater depth is given. As the plants come up they are thinned to six or eight stalks in the hill. Heavy seeding is practiced so as to overcome the tendency to loss from rotting or poor germination that the seed seems to possess. The ground should be pretty warm before seeding, and it is best not to plant until after the regular corn-planting



SHEEP'S FESCUE

This bunch grass is especially suited for the lighter, drier soils and those of a sandy nature where other grasses will not thrive. It is greatly relished by sheep, and to a less extent by other stock.

time is over. It is absolutely necessary to keep all the weeds out of the corn, otherwise the young shoots will be quickly smothered by the quicker, ranker, more virile weeds. Similar cultivation should be given sorghum as given to Indian corn. Shallow culture is to be commended. Sorghum for molasses is stripped of its leaves before maturity and the heads are cut off by hand. The stalks are then tied in bundles 6 or 8 inches in diameter and either taken to the mill or stored until convenient to do this. Cold weather is injurious to the cane and for that reason it should be got out of the way before frost comes on.

Sorghum for Forage.—For forage purposes the sorghum plant grows in popularity and its dominion is gradually being extended. In the drier portions of the country a small acreage is usually given to it on many farms. It is sown broadcast, 1 to 2 bushels of seed being used to the acre. The seed may be harrowed or disked into the soil. Cowpeas are frequently put in the mixture, from $\frac{1}{2}$ to 1 bushel of seed being used. A better balanced ration is secured in this way. Sorghum helps to hold up the cowpeas and a very heavy mowing is obtained. Sorghum draws from the soil great quantities of water. When grown one year the succeeding year the soil often shows less growth in whatever crop is grown than similar lands show. This indicates that the sorghum plant has great ability to get the small pickings out of the land.

It is not advisable, therefore, to follow sorghum with corn or a rank growing crop. Grass, cowpeas or the less greedy plants should be employed. In planting sorghum it is necessary to have the land free from weeds. If the land is weedy the sorghum

cannot make headway against them. For hay purposes, cut when the grain is in the dough, using a mower, binder, or, if planted in rows, a corn harvester. After cutting allow the sorghum to remain on the ground until it is partially cured, then rake up and store in shocks. Little difficulty is encountered in curing and if good-sized shocks are made they will, as a rule, turn the water. The sorghum hay can either be fed from the shocks or taken to the barn and fed or stored in stacks. From 3 to 12 or 15 tons of cured forage are made to the acre. Two cuttings give larger returns than a single cutting. More forage will generally be obtained from the sorghum than if the same land were given over to corn.

As a soiling crop sorghum is well liked. At any time during the summer the green forage can be fed to all classes of live stock, but it is generally used for feeding dairy cows. It is not advisable to allow either sheep or cattle to have free access to a green sorghum until they have got used to it, and often then death may occur to some, due to the prussic acid that is formed when sorghum is cured into hay. Feeding is done as with corn stover, either in the barn lot or in the open fields. As a silo crop sorghum has not proved a success. The most satisfactory returns from feeding the grain are secured when ground and fed in connection with some other feeding stuff relatively rich in protein.

Harvesting for Fodder.—Two methods may be followed in harvesting sorghum. The most common is to cut with mower, let it cure for a few days, then pile up in large shocks 8 or 10 feet high, and let it remain in the field until wanted for feed or

until it has dried out thoroughly, when it can be taken to the mower or placed in stacks convenient to the feed lot.

Begin cutting when some of the heads are pretty well ripened, as it will not do to cut early before the sugar begins to form in the juice. Do not be afraid of making the shocks in the field too large. There will be plenty of air space between the stalks and the larger the shock the greener and fresher the forage. Then, too, have no fear about the keeping of the fodder in the field. It is coarse and will turn water almost as well as a thatched roof. The outside of the shock will bleach, but just beneath the surface the fodder will be bright and green. Where the crop is heavy the shocks will stand very thick on the ground.

The other method, and one rapidly growing in favor, is to drill in rows and cut with the corn binder. Make the bundles very small, not more than 6 inches in diameter. Let them lie in the field until pretty well cured out. This may take a week or more if the weather is dry. It is best to be in no hurry about standing them up. If rains come while on the ground, the fodder is apt to be spattered with mud. If one has the time it is very satisfactory to stand, say, half a dozen bundles in a place and after they have dried for a time, build into bigger shocks, there practically being no limit, provided the tops are tied tightly together so as to keep out the rain; or, as in some places where the fodder is to stand out all winter, the tops are covered with bundles broken at the bands as cap sheaves for small grain stock. This method of harvesting is decidedly the best, as the crop is so much more easily handled in bundles than when loose. The bundles are hauled to

the feed lot or barn on a low wagon. It is useless to attempt to handle them with a fork.

SOY BEANS.—Like the cowpea, the soy bean wants warm weather in which to grow, and it oc-



THE SOY BEAN

It is a native of China and Japan. It is an erect annual, with branching stems and heavy forage much like the common field bean in appearance. The plant stands dry seasons extremely well and its domain is gradually being enlarged.

cupies about the same time in coming into maturity. The small dwarf varieties will mature in 90 days or less from the date of planting, but the time required for the larger sorts is from 120 to 140 days. The uses of the soy bean are somewhat similar to those of the cowpea. It may be grown to furnish grazing for cattle, sheep or swine, but in providing food for swine it has highest adaptation, although when thus grown and harvested by the

swine, the grain produced is the only part utilized. It is also grown to furnish hay and grain for stock. In some localities its highest use has been found in growing it for the silo. When made into silage along with corn it adds protein to the feed. It is also an excellent renovator of the soil.

Place in Rotation.—It may be given any place in the rotation, but it usually comes in best after some winter crop has been grazed down, and in some instances after it has been harvested. In the Northern states it may come after winter rye has been grazed down. In Central and Southern states it may be made to come after any winter cereal has been harvested. The soy bean will grow on a wide range of soils. However, it wants more fertile soil than will answer for the cowpea. It would not be wise to sow it on poor lands without the application of some kind of fertilizer. It grows well on nearly all the soils of the prairie region and it will do reasonably well on clays.

Varieties to Plant.—Far north in the United States varieties known as the Early Dwarf and the Extra Early Dwarf are among the best to grow. They may answer well to furnish gleanings for swine and also to fertilize the land when grown as a catch crop, as it were, in the summer season. Farther south, the two varieties known as the Early Yellow and the Medium Early Green are among the best. The former is a favorite in Kansas and the latter in Massachusetts. The Medium Late Green and the Medium Late Black will grow nicely farther south. The Early Green and Early Yellow both grow large enough to admit of putting them into the silo.

When the ground has been well mellowed and the crop is wanted for pasture in the green form, or for hay or manure, it may be broadcasted or planted in rows. When wanted mainly for the grain, the seed is put in rows with the corn with the grain drill more commonly, but sometimes with the corn planter or ordinary bean planter. In growing the small varieties, the rows may be as near as 24 inches. The largest varieties call for a distance between the rows of not less than 3 feet. The plants in the row will bear growing thickly, as the habit of growth is upright. The distance between the plants may vary from 2 to 5 or 6 inches, according to the size of the plants. The amount of seed used per acre is seldom less than half a bushel.

When once started, soy beans are hardy plants. They will stand being run over with a weeder or light harrow after they are up, without taking much harm. But one or the other of these implements ought to be used on them just before they appear, and then, if necessary, once after they are up. **Later**, the corn cultivators may be kept going until the season of bloom. With careful attention to the cultivation, hand hoeing may not be necessary. The cultivation thus given very effectively summer fallows the soil.

SPELT.—One of the types of the wheat family widely cultivated in ancient times. Outside of Spain, it is sparingly cultivated or used. In this country it has been used as a stock food only, and that largely in an experimental way. Both spring and winter varieties are found, but in neither case is the yield as great as with common wheat. Its most fatal disease is rust, but it withstands other

ailments better than the other wheat varieties. It has another good quality—its ability to hold the grain in the spike. Common wheat shatters very easily, but spelt never shatters. It is not believed that there is much future for spelt in this country.

SPURRY.—A plant highly esteemed as a pasture for cattle and sheep and for its fodder. It has been found specially valuable as a pasture for sheep and milch cows. Animals pastured on it are not liable to injury from bloat. Though they may not take kindly to the pasture at the first, they soon get exceedingly fond of it, both in the green and cured form. It also has good milk-producing and fattening properties.

Spurry is a tiny-like plant which grows from a few inches to fully 20 inches in height, according to the soil. The variety that has come into the market under the name of giant spurry is simply the ordinary spurry. It is not capable of making a stronger growth than ordinary spurry, as the name would indicate. The stems of spurry are numerous and exceedingly branched. They are fine in character, and they so interlace as to make it difficult to walk through the crop in an advanced stage of growth without tripping. The flowers are very many, are not more than one-eighth of an inch in diameter and are white in color. The seeds are small. They are contained in small seed heads resembling those of flax, but not more than half as large. They vary from dark brown to black in color. The plants seed profusely. On some soils the yield of fodder has been estimated as equal to that of clover, but ordinarily it would not be so much.

The plant has special adaptation for light, sandy soils, and for climates that are moist. Whether it will be given a place of much prominence in our agriculture has yet to be determined. On productive soils it is not likely to come into general favor, since other plants equally nutritious will give greater yields. But on light, sandy soils low in fertility it should render valuable service where moisture is sufficiently abundant. When plowed under in the green form it has been found specially helpful in giving body to the light, sandy soil, and in otherwise fitting it to grow successfully crops of clover and grain.

Spurry should be sown more as a catch crop than as a regular crop in the rotation. It should be ready to pasture or to plow under in from 6 to 8 weeks from the date of sowing, providing it is not sown before the weather has become warm. Where there is moisture enough to insure germination, spurry can be sown after a grain crop, and simply covered with a harrow. On the bare fallow it also has a place. When grown as a green manure or as a pasture for sheep, two crops a year may be secured, and in some climates three. This crop, therefore, is worthy of attention on the part of farmers, more especially on pine lands where the soil is sandy and poor and where the climate is moist in character.

Since spurry is best adapted to light, sandy lands, but little labor is necessary in preparing the soil. The seed should fall on a smooth, impacted and fine surface, and it may be sown and covered in the same way as clover seed. As the seed is small, a light harrow will give a sufficient covering. From 6 to 8 quarts of seed are sown to the acre to

provide pasture, fodder or green manure. But a less quantity will suffice to produce a seed crop in good form. It is ready to cut for hay after the seed has formed and before it is ripe. The seed may be harvested and threshed like clover seed. When grown for the seed, a sufficient quantity is likely to shatter out to produce a crop the next year by simply running the harrow over the land in the early spring.

Spurry has been called "the clover of light, sandy soils," because of its value in improving the same, both in texture and fertility, when grown as a green manure. It should be turned under with a light furrow that the plant food may be kept near the surface. If some of the seed is allowed to ripen before the crop is thus buried, another crop of spurry will grow above the decaying plants without the necessity of sowing any more seed. Under some conditions it is possible to plow under three crops of spurry in one season.

SUGAR BEET.—A root crop for sugar and feed. The dried pulp, a by-product of the sugar factories, is an excellent food for live stock, especially for dairy cows. So, too, are the whole roots good, but they cost too much. The beets are much relished by stock and their physiological effect is an aid to digestion like all succulent rations. The dried pulp acts in this way and compares favorably with many concentrate feeds. When grown under proper cultural conditions the amount of sugar will vary from 12 to 20 per cent, depending on the variety and soil. Most of the seed is obtained from Europe, though small amounts are now being secured in this country, with possibilities that the industry will be enlarged.

To grow beet seed special technical skill is required. It is always advisable to know how much sugar is in the beet before it is allowed to mature for seed purposes. It is by patience and industry that it is ascertained and because of them the high sugar content of beets has been developed. Chemical manures are necessary in growing beets except in the most fertile soils. Phosphorus and potassium are especially important. The use of phosphatic fertilizers has a tendency to increase the sugar content of the juice. Except in connection with phosphorus and potassium nitrogenous fertilizers should be sparingly applied. If used excessively they produce abnormally large beets and the sugar content is low. They should always be grown in

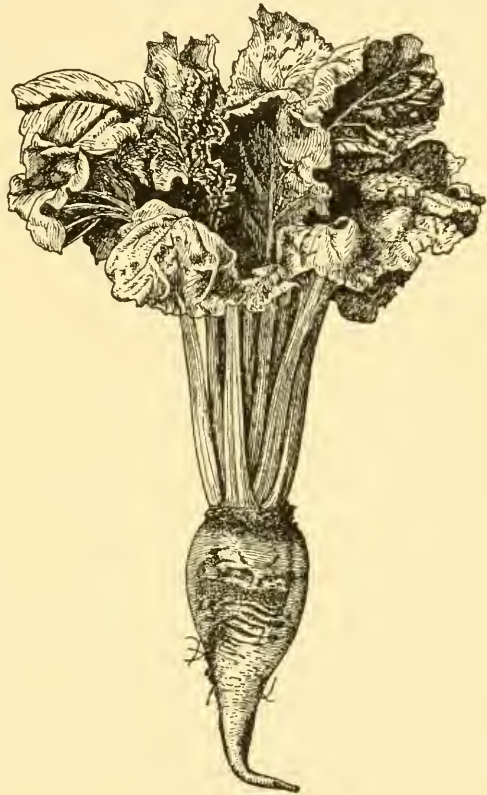

SUGAR BEET

The two most commonly grown varieties of sugar beet in this country are the Vilmorin Improved and Kleinwanzlebener. The former usually analyzes a little higher percentage in sugar, but the latter gives the higher yield. Most of the sugar beet seed used in this country is grown in Europe.

some rotation system, a popular one being corn heavily manured with stable manure the first year, followed by beets the second, oats or barley the third, and clover the fourth. Then corn again, the rotation being repeated. By applying the barnyard manure to the corn the weed seeds will be sprouted and killed in cultivation. The rank growth that barnyard manure tends to cause will be lost by the time the beets come in the rotation and the soil will be put in excellent condition for the beet crop.

Preparing Land for Sugar Beets.—The best soil for the sugar beet is a strong, rich, well-drained loam, with a porous subsoil. The beet does well on a great variety of soils provided the land is properly prepared, but at the start only those fields should be put into the crop that from the best obtainable knowledge are believed to be well adapted to the crop. It is important that the land should be in a good degree of fertility, and, so far as possible, free from weeds.

The main thing is deep plowing. Here is where the average farmer errs when he begins beet culture. Deep plowing is needed because the beet is a deep-rooting plant. To make the best growth, richest in sugar, the soil must be so deep that the plant will bury the top of the root under the soil, as the parsnip does, and at the same time be able to send its taproot down without let or hindrance.

Of course fall plowing is best. But whether spring or fall plowed 8 to 10 inches deep is necessary. Put on a stout team and plow 8 to 10 inches deep, provided you do not turn up an inch or two of fresh soil that has never before seen the light of day. In many cases, too much of this fresh soil

on the surface will retard germination of beet seed and interfere with the best development of the young plants. The ordinary plow should be followed by a subsoil plow that will stir the subsoil several inches below the depth reached by the first plow, but not throw the subsoil on top. The more compact the subsoil, the more necessary does this subsoiling become. Indeed, it cannot be dispensed with, at least where the entire preparation of the land must be done in the spring.

Having thus reached a good depth with the two plows, put on a spike-toothed harrow with long teeth and weight it so that it will reach as far down as the first plow went. If you have a narrow-toothed cultivator for such deep work it would be still better. There are various forms of cultivators or harrows that can be used. This will give you a soil thoroughly pulverized down to a depth of 6 or 8 inches, and quite well opened up. The surface should now be prepared for seeding by going over it with a light harrow that will give a seed bed 2 or 3 inches deep in a perfectly fine condition. If the soil is very dry and there is danger of its blowing in heavy winds, it may be well to roll it.

Sow the seed in drills 20 inches apart. A variety of excellent seed drills or machines is available for this purpose. Better use too much than too little seed, as the beet is not successfully transplanted. If the soil is reasonably moist and the weather warm, thus favoring germination, several pounds less an acre may be used than if the land is wet and the air cold. Better use 15 or even 20 pounds of seed an acre than have a slim stand because of too little seed. This is a point upon which there

are great differences of opinion; all the way from 3 to 20 pounds of seed are used, but experienced growers usually plant about 10 or 12 pounds. The rows should be about 20 inches apart to permit of horse cultivation, but 14 inches apart will do for hand culture.

When the outside leaves take on a yellowish tinge and drop to the ground the beets are ripe and should be harvested. The mature beets are richer in sugar than the immature, and the more mature when pulled also the richer the sugar. The beets may remain in the soil for a considerable time after ripening without injury. Cold weather does no damage if freezing and thawing do not alternate. The sugar content will be lessened if the beets start a second growth in the fall. The harvesting is done either by special sugar beet pullers or by plowing down one or both sides of the row to loosen the beets so that they can more easily be pulled out by hand. The tops are cut off, including that part of the root to which the stems of the leaves have been attached.

Upon being harvested they are either stored or sent to the market at once. If stored they should be put in long narrow piles and covered with sufficient straw and earth for protection against frost. If too much earth is added in early fall the beets may get warm and ferment, thus losing some of the sugar. A ventilator placed at the top of the pile will enable the heat and moisture to escape.

SUGAR CANE.—A gigantic grass with fibrous roots which reach laterally in every direction. The stalk is a cylinder, varying in diameter from 1 to 2 inches with joints from 2 to 6 inches apart on the stalk. The stalks vary in color, running from white

to black and even yellow, green and purple. Formerly it was thought that sugar cane could be grown only in tropical lands, but it is now grown very successfully in this country, especially in Louisiana. Much cane is grown in Georgia, Alabama and Mississippi. An enormous amount of water is required for the best development of the cane and where the rainfall is deficient irrigation is practiced. While water is required in great abundance, a well-drained soil is absolutely essential to vigorous growth and to large, mature canes. The soils best adapted to canes are those which contain the largest amount of fertilizing material and which have a large water-holding capacity.

Cane is usually planted in 5 to 6-foot rows. A trench is opened in the center of the row with a plow and in this open furrow is deposited a continuous line of stalks which are carefully covered with plow, cultivator or hoe. From one to three continuous lines of stalks are placed in the furrow. From 2 to 6 tons of seed cane are required for an acre. In favorable seasons this cane soon sprouts and then cultivation begins. Each young sprout sends out many shoots and soon the entire row is filled with cane. Being a rank grower large quantities of fertilizers are needed. The usual quantity to an acre varies from 400 to 700 pounds. The cane is harvested annually on account of the frost of winters which would be destructive to a good yield of sugar. The sugar content varies from 11 to 16 per cent. The sandy soils of Georgia, Florida and Alabama give a richer juice than the alluvial soils of Louisiana.

The cane is crushed for sugar before winter and the crop harvested before frost comes. The leaves

are stripped off and the first and sometimes the second of the upper joints removed. The yield of sugar cane varies from 10 to 50 tons to the acre and the amount of sugar in a ton of cane from 100 to 300 pounds, besides a considerable amount of molasses. The sugar from the cane may be manufactured on a small scale and with comparatively simple machinery. For the economical production of sugar of the best quality an expensive plant is necessary

SUNFLOWER.—A native annual from 8 to 20 feet high with heads from 8 to 16 inches in diameter. The seed is gray, brown or striped. In growing a crop of sunflower the land should be prepared as for corn. The seed is placed in drills 2 or 3 inches deep, about 3 feet apart and about 15 pounds of seed to the acre. When the plants are from 6 to 8 inches high the rows should be thinned, leaving one stalk to about 16 inches on an average. Slight frosts do not injure the plants and maturity of the crop is generally reached. The sunflower heads should be harvested before the seed is fully ripe else much will be shattered out and lost.

When thoroughly dry the heads are beaten out with a flail. Seed may be stored in small bins or barrels. Avoid a large quantity in one place or bin in order to prevent heating. From 750 to 900 pounds of seed are obtained from an acre with the price running from 3 to 4 cents a pound. The seeds are used for different purposes; for making oil, for bird and poultry seed and for stock feed. Very often the sunflower heads are mixed with corn for silage, and they make a very superior feed. Butter resulting from this kind of feed is of rich flavor and of high color. The Mammoth Russian is an im-

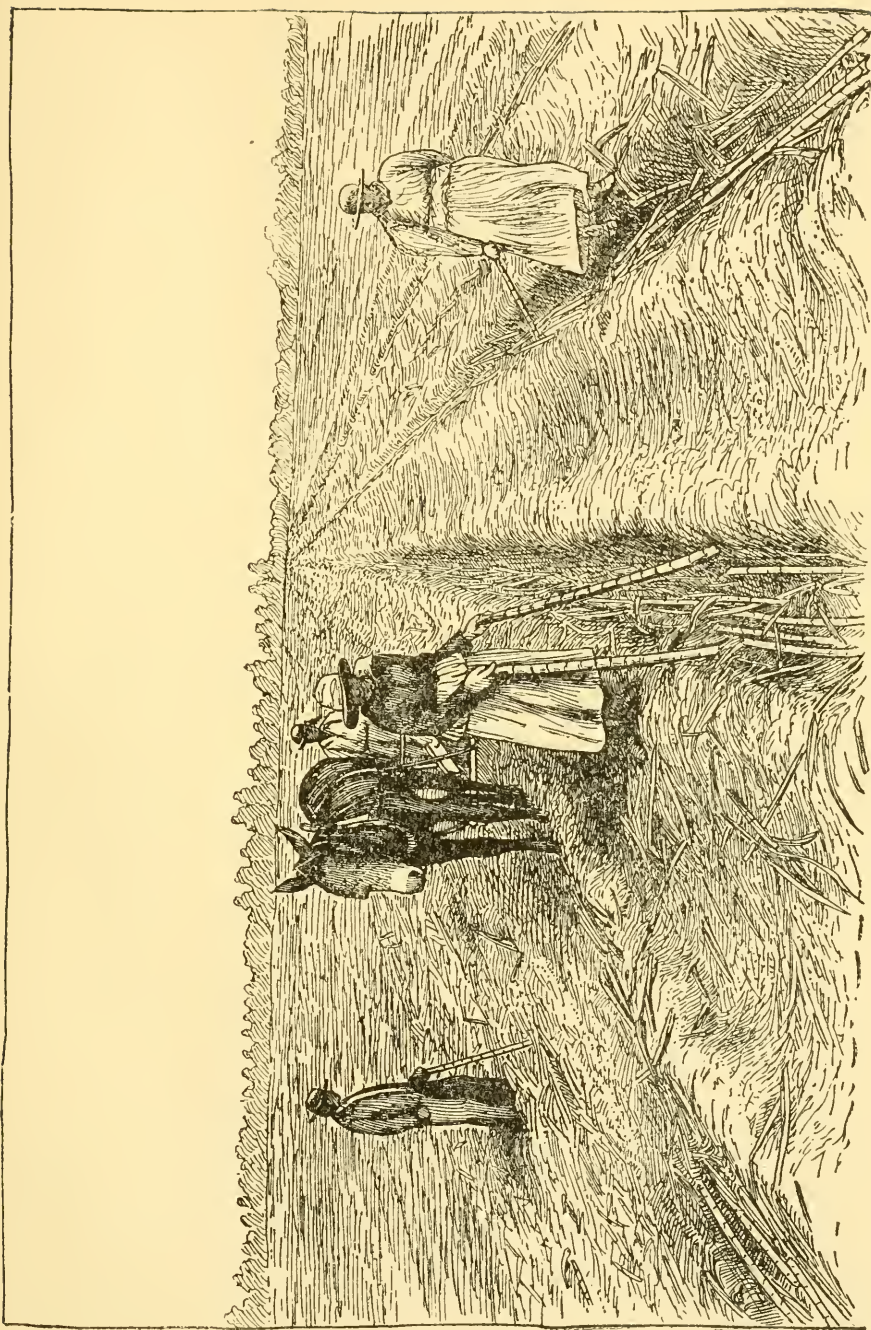

SUGAR CANE; LAYING THE CANES

proved variety with seeds about $\frac{1}{2}$ inch long, black in color or with brownish stripes. The heads run from 15 to 20 inches in diameter. It is one of the best varieties for the production of oil.

Black Giant, another popular variety, has heads ranging from 15 to 20 inches in diameter. The seeds are not quite as long and are black in color. A silage mixture known as Robertson's mixture is a mixture of sunflower heads, horse beans and corn, in the proportion of two acres of corn and beans to one-half acre of sunflowers. This mixture, although much publicity was given it a few years ago, has not come into use in this country. The sunflower has a narrow field of usefulness; if grown at all on most farms, it will be for a limited supply of poultry feed.

SWEET CLOVER.—A strong, vigorous growing biennial. It is branched and upright in its habit of growth. It is one of the most hardy plants of the clover family. When once firmly rooted it has great power to withstand drouth and heat, and it can also endure low temperatures. Being a ravenous feeder it is able to maintain itself in soils too poor to sustain other species of the clover family. It is a legume and one which has much power to renovate soils. A plant, therefore, which is possessed of such powers should not be looked upon as worthless. It has not been much grown for pasture, but for such use it may yet prove to be of value. When sheep, for instance, have access to a variety of grasses they usually pass sweet clover by, even when it is young and tender. But if confined to such a pasture when it first begins to grow they soon begin to crop it down.

Sweet clover can be sown only in the spring or summer in very cold latitudes, but in those that are mild it can be sown in the autumn or spring, preferably the former. Usually not less than 15 pounds of the seed is sown to the acre. In the South it is frequently sown on the surface of stubble lands after the crop has been harvested, and when thus sown it is only covered by the harrow. If sweet clover is kept from blossoming, the land will soon be freed from it. Although it seeds profusely, the high price of seed at the present time stands much in the way of extending its growth.

SWEET POTATO.—If one wishes to set out 100 to 200 sweet potato plants it may be cheaper to buy them from a local dealer, or if they cannot be obtained from him, to send to a seedsman and have them sent by mail. If one wishes to set 500 or more plants he had better raise them himself. For growing plants the seed should be placed in a hotbed in soil about 2 inches above the manure and covered with at least 3 inches of soil; 4 would be better. Place the seed potatoes one deep as closely together as may be without touching. When they are covered, press the soil down over them firmly. The ideal size for seed is $1\frac{1}{4}$ inches in diameter. Be sure not to use seed that shows any sign of black rot or any other fungous disease. A peck of seed will raise 500 plants at the first pulling. If care is taken not to disturb the potato when pulling the plants, there may be a second pulling.

Soil and Fertilizers.—A warm, sandy soil of fair to good richness is to be preferred. If this type is not available any kind may be used, but sticky soils

ought to be avoided. They run together and lessen the yield. Well-rotted barnyard manure is helpful to any soil and will be splendidly accounted for if added to the sweet potato patch. The best time to apply is during the fall and winter months.

For fertilizing a complete manure is best, especially if the land is old and possessed of little humus. A mixture consisting of 200 pounds of nitrate of soda, 650 pounds of acid phosphate and 150 pounds of sulphate of potash makes a very satisfactory fertilizer. Anywhere from 200 to 1,000 pounds of this mixture can be used to the acre. In case the soil is already supplied with organic matter, nitrogen in the fertilizers applied may be omitted. Potash is of most importance, and especially desirable; phosphoric acid also, although in a less degree.

The Farmer's Little Patch.—The plants need not be very large, but should be well rooted. As the plants are pulled they should be put in bundles of from 25 to 50 each, and in this shape they can be placed in a vessel of water and kept several days without injury. In preparing the soil for setting the plants, the ideal way would be to use ground that was plowed in the fall before and simply work it up fine before planting. But in case this has not been done the ground should be well pulverized, then rolled or packed, and then laid off in ridges 3 feet apart from center to center. Ridges are best made by running a small plow once on each side, which gives a flatter ridge than if a larger plow were used making one of loose dirt compact at the bottom.

The plants should be placed about 15 inches

apart. In setting them use a dibble and after inserting the plant in the hole press the soil firmly about it. A week or two after the plants are set, a cultivator may be run between the ridges and although it may tear them down somewhat, it will not disturb the plants. It might be well about this time to hoe between the plants, or probably a little later. The plants should not be set until danger of frost is over. The setting may be done in any way most convenient, provided plants in good condition are set firmly into good, moist soil, preferably late in the afternoon or evening, or on a cloudy day. If set in this way no watering is needed, but have the plants wet at the time of setting. If the weather is hot and the ground very dry it will be necessary to use water.

Setting Large Areas.—When many plants are to be set and the ridges are in good condition, run a furrow a little to one side of the center of the ridge with a hand wheel plow and have the plants dropped on the side of this furrow, which is in the center of the ridge. A man follows and covers with a hoe, stepping on the soil over each plant with his whole weight, thus packing it firm and tight. Plants are dropped at a distance of 12 to 24 inches apart, according to the variety and the purpose for which they are being grown, but about 15 inches apart is the usual average.

In a week or ten days after the plants are set, they should be gone through with a cultivator. I like the harrow cultivator best for the first time. At this time they should also be gone over lightly with the hoe and if any of the first setting have died they may be replaced in order that the stand may be as perfect as possible. After this the cultivator

should be run through them once a week until they begin to vine considerably, or enough so that in a short time the whole surface will be covered by them. During the time of cultivation the hoe should be used freely and often, and all weeds and grass destroyed soon after the plants make their appearance. Also the soil should be kept hoed to the plants rather than away from them and at the last plowing it is usual to use something larger than a common cultivator—a large single shovel having the preference.

Treatment of the Vines.—If the vines get quite long before this last plowing it may be necessary to turn them into each alternate middle, plowing the one from which they have been turned. They are turned into the middles, freshly plowed, and the remaining ones also plowed. A little hand work with the hoe after plowing is done, drawing up a little earth here and uncovering a little there where the plow may have thrown too much, and the labor of cultivation may be considered finished. In a short time the vines will cover



TALLER FESCUE

the whole ground and keep down all weeds and grass, provided there was none left at the last cultivation, and a bountiful crop may confidently be expected, if the soil is good and the work has been thoroughly done.

TALL FESCUE.—Also known as tall meadow fescue and taller fescue. The leaves are rather fine.



CUTTING WHEAT IN THE WEST

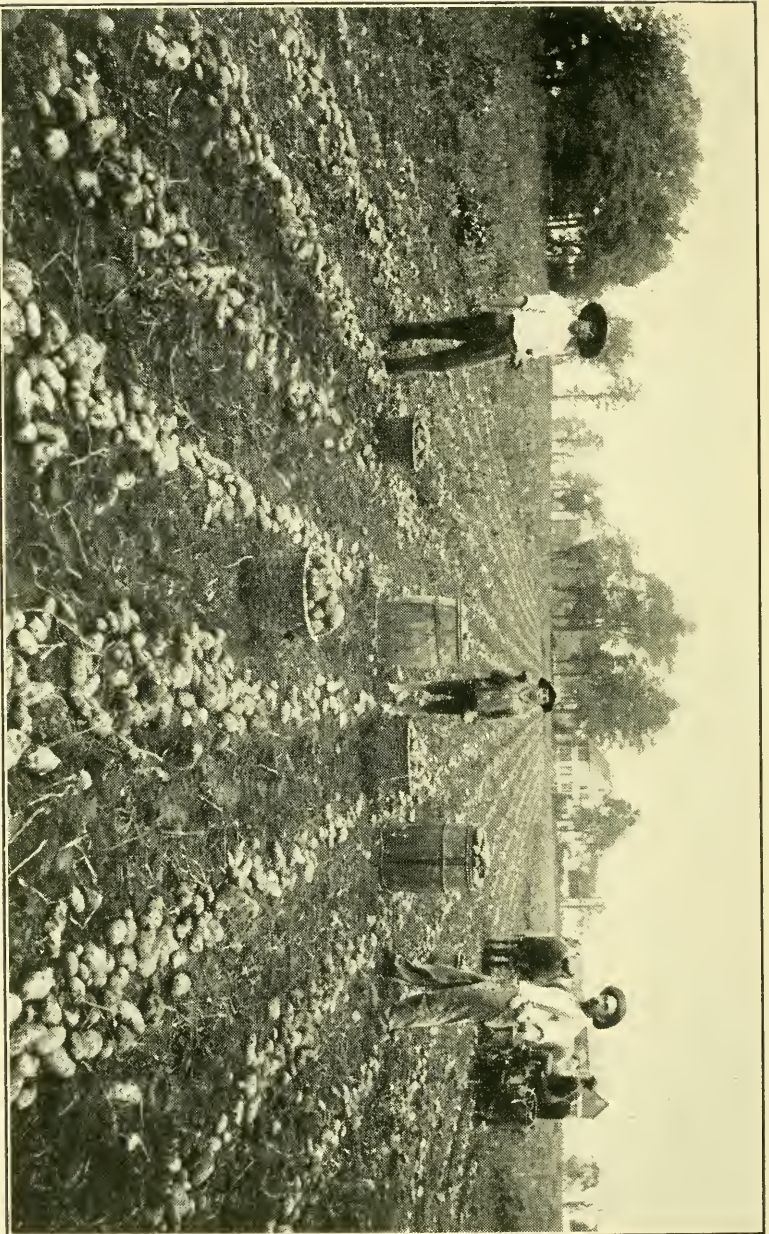

WHEN POTATOES PAY

The trinity of success in potato growing is good soil, good seed and good culture.

This fescue is adapted to pasture or meadow, but is inferior to timothy as a hay crop. It is a palatable hay, cattle preferring it to timothy or red top. It starts in the spring at about the same time as Kentucky blue grass. In seeding a fine compact soil is desirable. Some time is necessary to get the plant established—at least two or three years—before a good sod is secured. Because of this fact, together with the high cost of seed, the tall fescue is not adapted for temporary pastures. When to be grown, use in a mixture with the common grasses of the section.

TALL OAT GRASS.—A strong fibrous perennial growing from 3 to 5 feet high. It is hardy, a good drouth resister and produces heavily both of stems and leaves. If grown alone it makes unsuitable hay because of its coarseness and woody nature. Mixed with other grass seed like timothy, red top or the fescues it can be very satisfactorily used, and adds to the value of the mixture. Well-drained and fairly rich soils are best liked by it, but it will grow on uplands and in all soils that are favorable to timothy and red top. As soon as the blossoms appear the crop should be cut. The sec-



TALL OAT GRASS

This European perennial produces an abundance of leaves and tall stems, is hardy and resists drouth well. It is unsuited for hay except in mixtures. It is considered inferior to either timothy or orchard grass.

ond season gives a better yield than the first. Usually two cuttings and sometimes three are obtained annually and from 2 to 5 tons to the acre. In providing a mixture, it is a good rule to use only a small proportion of this grass in the regular mixture.

TEOSINTE.—A forage plant closely related to corn. It is an annual and in appearance much like corn with no ear formed. The tassel looks very much like corn. It grows very rank, stands from 10 to 15 feet in height and bears a great quantity of leaves and tender stems. A single root may possess 40 to 50 stalks. A rich soil with a good deal of moisture is demanded by it and it fancies hot climates. It cannot resist drouth and for this reason in the drier sections of the country sorghum and kafir corn are more desirable crops. It is grown very little in the Northern states, its preference being for the South along the gulf. The best time to plant is in the latter part of May or early June. It is put in drills 3 to 4 feet apart and planted 12 to 16 inches apart in the row. If hill planted three or four seeds should be used to the hill and the hills placed 3 feet apart in the row. Rich lands call for less seed than poor lands. Generally speaking about 3 pounds of seed are used to the acre when thick planting is resorted to and 1 pound to the acre for rich and fertile soils.

The crop is best used for soiling purposes. It is so juicy and succulent that to cure it, especially in moist regions, is well-nigh an impossibility. It has been successfully ensiled, but is not so good for this purpose as corn. One beauty about the crop for soiling purposes is that it can be cut several times during a season. If allowed to mature and used as dry fodder it makes a very heavy yield,

running several tons of dry matter to the acre. For a forage and soiling crop there is no reason why teosinte should not be more generally grown than it is. Stock relish it, and its food value is high. There is very little of it wasted when fed. It is a crop that should be well tried out by dairymen.

TIMOTHY.—Clean timothy hay is the standard of commerce in this country. By it all other hays are compared. It is the most expensive hay either when fed or purchased. It is expensive when purchased, because it is the highest-priced hay and when fed because its feeding value is not commensurate with the price. As a feed it is low in protein; much lower than any of the legume hays. Its great popularity is due, perhaps, more largely to the fact that it is usually free from dust. It is commonly fed to work horses throughout the land, often being sent long distances to regions where it does not readily grow. But the native grasses or legume hays, if properly cured, would make as clean feed and more satisfactory feed for farm horses, because the nutrients contained are in all cases better balanced.

The popularity of timothy hay makes its growing remunerative to the farmer. It is to his advantage to dispose of timothy at high prices and to purchase other hays and grains with the money received. He will not only get a better feed through the exchange, but something to boot at the same time. This grass likes a moist soil and does its best on rich lands. It is a perennial and grows from 2 to 5 feet high. It abhors sandy soils and shows it by a scanty growth. The clay loams attract it and on these or moist lowlands the best returns are secured.

Timothy is an exhaustive crop. It adds no nitrogen to the soil as do the legumes, and not much humus is ever returned to the land. Its shallow feeding fibrous roots are not helpful in subsoiling the earth as do most of our other farm crops. Being a shallow feeder, the roots suffer if dry weather continues for any length of time. Timothy is responsive to top dressings of stable manure, to nitrate of soda and other chemical fertilizers. While most timothy fields may be pastured heavily, pasturing during wet weather is very disastrous. The common practice that prevails throughout the country of seeding timothy on wheat lands, to be followed the following spring by clover in the standing wheat is an excellent one. After the wheat is harvested the clover shows splendid growth that summer, and is at its best the following year. Timothy, being a slow-growing crop, does not show much activity the first or second summer. During the following spring and summer, when the clover has pretty largely disappeared, the timothy becomes strong, healthy looking and vigorous. You see, the clover helped not only the land, but the timothy crop also. The deep-growing roots penetrated into the subsoil, bringing phosphorus and potassium from the storehouse beneath and left much humus in the soil; and their graves were rich in nitrogen, a gift to the timothy that is very satisfying and manifested in the subsequent crops. Wheat is a good nurse crop for timothy, but timothy may be grown without a nurse crop. Good results are secured from both methods. If seeded in the fall, seed right with wheat. The compact condition of the soil secured in preparing the land for wheat is just what timothy likes, and whether seeded alone

or with wheat or oats or barley, the soil should be fine, mellow and compact. If seeded alone, from 12 to 15 pounds are used to the acre, and if seeded with wheat about 10 pounds to the acre, followed with from 5 to 10 pounds of clover the following spring.

When clover and timothy are mixed the hay is not so valuable if feed markets are catered to, but the farmer always has need for this hay himself. It is good policy to keep this mixed hay for home use and to sell the clear timothy to the feed man who is willing to pay a high price for it, even though he secures a less valuable feed. There seems to be no special rule for cutting. Some cut very early; some very late. The ideal time, as shown by chemical analysis of the crops, is when the blooming period has passed, say when the blooms begin to fall. This gives a nutritious food and it is more appetizing. The yield varies; frequently hay lands in which timothy predominates have been so long in hay that a small yield only is secured, often as little as a half to one ton to the acre. Where good culture is given the meadow lands, especially those in rotations, far better yields are secured, running from 2 to 4 tons to the acre; often cuttings of timothy and of clover vary from 6 to 8 tons to the acre in a single year. If seed is desired, let the crop stand until the heads are brown and the seeds fairly ripe. It is then cut with a reaper and the bundles put in shocks. After curing a week or ten days, it is ready for threshing with yields varying from 5 to 15 bushels to the acre, depending on the stand and the vitality of the grass.

TOBACCO.—A plant native to this country and consisting of many varieties, each of which requires special soil preparation and culture. Being a highly specialized crop, the utmost care and attention is necessary in selecting soil and in cultivating the crop. Until recent years, the small details of culture have been left unattended, thereby lessening the returns in production. When tobacco sells at a normal price, on the same basis as other crops of the farm, none gives a larger profit to the acre, especially when the details of culture and of curing are not neglected.

Unlike other farm crops, tobacco requires much devotion at first to get the crop started. A seed bed is necessary in which to start the plants from which they are later removed and transplanted in the field. The old method in the South was to cut a clearing in the woods near a small stream; a southern exposure is preferred. This land is spaded in the fall, wood is burned over it so as to put it in good condition and to fertilize the bed. Many growers cover the selected seed bed during the winter with leaves and manure so as to keep it from freezing. In the spring this top dressing is removed, a liberal application of cottonseed meal or some nitrogenous fertilizer is applied and raked in, leaving the soil in mellow, fine and compact condition—just the condition that the tiny seeds require for their best germination and growth. It takes from the time of planting in the seed bed, until ready for transplanting, many weeks. To shorten this period many farmers germinate the seed before sowing in the seed bed. They moisten the seed and place it in a medium like apple tree punk or cocoanut fiber made soft with warm water.

The temperature is kept around 70 to 75 degrees. When the seed begins to germinate it is mixed with fine ashes and sown broadcast on the beds at the rate of a teaspoonful to about every 10 square yards. The seed bed is now left to itself and the



TOBACCO

In topping tobacco, the bud is broken off at the top of the stalk. This is done when the button is well put out. By this means, the leaves grow much larger, ripen up more evenly, and their quality and appearance are much improved.

field in which the plants are later to be transplanted is put in shape.

Unlike other field crops, tobacco is very particular about the soil in which it is to grow. Hence only a small part of any farm is usually available. The land should be plowed deep, and harrowed at least once a week until transplanting time. From

one to three weeks before the plants are set, the rows are laid out, usually 3 to 3½ feet apart. The distance between the rows varies with the different varieties and the localities. When the plants are from 4 to 6 inches high in the seed bed, they are ready for transplanting. The bed is thoroughly watered so as to prevent injury to the roots. Pulling up in the morning is a good practice as the leaves, in doing so, are less liable to be injured. The plants are now packed in small boxes or baskets with the roots pressed together, the same as with cabbage or sweet potatoes. These are covered with a damp cloth and set in a cool, shady place until ready to be set out. If the weather is warm and clear, planting late in the day is preferable, but if the weather is dark and cloudy, anytime will do. Transplanting machines are now replacing hand planting.

Cultivation.—In ten days to two weeks after the plants have been set out, it is advisable to start cultivation. The real secret of growing good tobacco is in keeping the land free from weeds and the soil in the best of tilth. Cultivation, therefore, should be thorough and continuous; and shallow cultivation is preferable to deep cultivation. Any injury to the plant roots will check the growth and thus affect the leaf. Rapid growth gives a finer leaf than the slow growth. This is one reason why the soil needs to be fertile. When the plant begins to bud, horse cultivation should cease.

All plants excepting those that are to be kept for seed are topped. During the season, the suckers are usually removed two or three times. If the suckers be permitted to grow, an inferior tobacco would result. Tobacco raisers should make it a

rule to select seed from plants having few suckers and those that have a tendency to resist all diseases. The flower clusters should be covered in a paper bag before blossoming so as to prevent accidental cross fertilization. As the plant grows, these bags should be loosened or larger ones used so as to avoid any injury to the tops of plants as they grow bigger. After the flowers that are to be used for seed purposes are fertilized, the bags should be removed and the seed allowed to mature in the open.

Culture Points Summarized.—The soil should be given a heavy coat of barnyard manure in the fall, plowed either in the fall or early spring, and harrowed at intervals of about every two weeks. This will cause most of the weed seeds to germinate and give the farmer ample chance to kill them before he plants tobacco. The early plowing will, if harrowed in this way, absorb all the spring rain and better enable the plant to withstand possible drouth of the summer months. After transplanting, the ground should never be allowed to bake. Cultivate after every shower, preferably with a drag-tooth cultivator. This will leave the ground fine and not lumpy like some of the old-fashioned cultivators. The plant should be in the highest degree of health from the time it is transplanted until harvested, and this can be accomplished by constantly tilling the soil until the plants are so large they will not permit a horse to walk between the rows, but care should be taken not to go too close to the plant when it has attained any size. Tobacco should be topped just as it is beginning to flower. It should never be allowed to bloom. Conditions of weather and climate determine the length of time a plant

should stand from time of topping until harvested. Generally this is about 18 to 20 days. In very warm growing weather 16 to 18 days will suffice. No rule can be used for this. Experience is practically necessary to judge ripe tobacco.

When to Harvest.—It is best, especially in dry seasons, to harvest the tobacco before it is too ripe. If the rain should come to freshen the plants, and start them growing let them stand until they are matured, otherwise harvest the tobacco before it starts to fire up in the field. Much has been said during the past few years concerning the harvesting of tobacco by the priming method. This is to pluck the leaves as they become nearly ripe, instead of waiting to cut the whole stalk. Some have made a success of it and others have not. The principal drawback to the method is the little knowledge we have of the proper stage of ripeness tobacco should acquire to be in its prime for harvesting in order to make the best quality of goods possible.

The main point is not to delay the harvesting until the tobacco is too ripe; better by far have it a little on the green side of the line. As soon as the leaves are matured; that is, have their growth, they should be harvested. The longer a leaf stays on the stalk after it has its growth, up to the time it starts to fire, the more solid matter it contains. If the leaf so loaded with solid material is cured on the stalk, a part of the solid material in the leaf is made soluble during the curing process and transposed into the stalk, thus benefiting the leaf; if the leaf is primed in the field this source of outlet for the solid material is cut off and the leaf cures down thick and boardy, instead of thin and

elastic, as it does when harvested as soon as it has obtained its growth.

TURNIPS.—The turnip is of many varieties. They are sometimes called fall turnips, because they are more commonly fed in the autumn, whereas the Swedish varieties are more commonly fed at a later period. They are characterized by differences in the size, shape and color of the bulb, and by the habit of growth in the top. Compared with rutabagas they are flatter in shape, they grow more quickly and more above the ground and are less firm in flesh, hence they cannot be kept so long when harvested. They are more frequently grown to provide forage than rutabagas, because of their quick-growing properties, and because it would not be so remunerative to harvest a crop that keeps but for a short time. Sometimes they are raised



TURNIP

The turnip is the favorite root of sheep. Its use as a field crop is steadily growing in this country.

for forage by sowing the seed in drills and cultivating the plants, but more frequently they are sown for this purpose in the grain fields. They furnish forage for all farm animals, but are best adapted to sheep and swine. To provide forage they are commonly sown with a winter grain crop, as wheat or rye; or with a spring grain crop, as wheat, oats or barley. But they should not ordinarily be sown with a grain crop that has also been sown with grass seeds, for the pasturing in the

autumn would very probably prove hurtful to the young grass. With a winter crop they should be sown early, so that it will not too much shade the plants while they are young and tender. With a spring crop they should usually be sown at the same time as the grain, but may be sown later.

From 1 to 2 pounds of seed will usually prove sufficient to sow to an acre. On winter grain crops the seed will have to be broadcasted. It should then be covered with a harrow. The harrowing will also be helpful to the grain when it is judiciously done. On spring grain it may be sown with the grass-seeder attachment of the grain drill when it has one, and except on stiff soils the seed should fall before the drill tubes. When the seed is thus dropped before the drill tubes it will be sufficiently covered. When it is sown just after the grain it will, in nearly all instances, be necessary to cover it with the harrow, except on lumpy or cloddy soils. On these the roller ought to be used rather than the harrow.

Of the various kinds of spring grain, barley makes the best nurse crop for turnips, because of the less dense growth which it produces, and because of its early removal. Oats is the most unsuitable as a nurse crop for reasons just the opposite.

The value of the turnip crop for forage will depend much on the character of the season and soil. In any case, the turnips are not likely to grow so as to hinder growth in the grain crop. But under favorable conditions they will come on after the crop is harvested and will produce an excellent growth of top and root. In very dry seasons they may not give any return, but in turnip-growing

sections it is seldom, indeed, that the crop will not be found worth more than the seed and the cost of sowing it.

The sheep or other live stock that are to be pastured on the turnips may be allowed freedom of access to other grass pasture; the outcome will be still further satisfactory for the danger of an unduly lax condition of the bowels is less likely to occur. The pasturing should be completed before the weather becomes really cold, for turnips freeze much more easily than rutabagas, and when hard frozen they should not be eaten by the stock.

VELVET BEAN.—A twin-ing plant important as a cover crop and for its value as a green manure. It gets its name from the velvety condition of the pods and looks much like pole lima beans. It requires a long growing season, considerable moisture and much warm weather. For these reasons it is best adapted to the Southern states, and there it reaches its maximum growth. It is not very particular about the soil allotted it, but does its best on fairly well-drained soils that are fairly fertile, but it is all right for bringing up old lands. Being a legume in most cases it can supply its own nitrogen, but in poor soils potassium and phosphorus should be supplied.



VELVET BEAN

This legume grows from 10 to 50 feet in length. Its flowers are in clusters at the joints of the stem. The beans are borne in short cylindrical parts containing three to six large rounded brown and muddled seed. The buds are covered with a velvety down which gives the name to the plant.

It is planted in rows about 4 feet apart with the plants 2 or 3 feet apart in rows. About 4 quarts of seed to the acre is the customary seeding. As its best work is to build up the soil it makes an excellent crop to precede corn or cotton. Sometimes corn and velvet beans are planted together. A few cultivations should be given the crop after planting to keep the weeds down and to conserve the moisture. The vines grow rapidly, and soon shade the ground and smother out weeds, but the cultivation makes the soil more agreeable to the crop.

In harvesting the mowing machine is best. The tangled condition of the crop and its immensity make it difficult to cure. It is cured very much like cowpea hay or clover hay, only it is many times more troublesome. These curing difficulties lead most people to graze the crop with cattle and hogs and to plow the wasted part under for the soil improvement effect. If cured as hay, from 3 to 4 tons are ordinarily secured from each acre. An average yield of seed is about 35 bushels. As a stock food the velvet bean stands high. The protein content is large. When fed carbonaceous feeds like corn, cassava and bulky foods should be provided also. Its best use is as a cover crop and as a soil renovator. In regions where it can be grown it has few equals and no superiors.

VELVET GRASS.—Often called a weed, this plant is used for pasture and hay along the Pacific coast. It flowers early in the spring and attains a height of from 20 to 30 inches. As a forage it is not very appetizing, but is nutritious. It is a ready grower, preferring soils possessed of considerable organic matter. In seeding about 20 pounds are required to the acre and the soil should be prepared

as for other small grass seeds. Velvet grass is not a popular plant and will never replace any of the well-known grasses now commonly used for meadows and pastures.



VELVET GRASS

VETCHES.—These plants sometimes called tares are relished by live stock of all kinds. They are excellent for milk production and their fattening properties are of a high order. They have special adaptation for being grown along with other grains to provide soiling food and they may be made to render excellent service in providing pasture for sheep and swine. When grown for hay vetches should be sown with some cereal grain to sustain them. Not only are they good food, but they belong to the legume family and are good land renovators. For this reason they are excellent to follow

cereal crops. They grow splendidly on overturned sod land. Winter vetch may be made to follow a crop that has been harvested in the summer or fall. After the vetch crop has been harvested the following spring the summer crop should succeed it.



HAIRY VETCH

Known also as sand vetch. It is a legume and a great soil improver. It does well with wheat, rye or oats which furnish support for the vines and keep the forage off the ground. It may be used for green forage, for hay, for pasture, or it may be turned under for green manure.

sprout the seed, otherwise it will lay unsprouted in the ground. The seed may be broadcasted, but is better sown with a grain drill either when sown alone or along with other seeds. It should be buried about as deeply as cereals. The hay of the common vetch is about as nutritious as clover and is relished even more. On account of the high value of the seed it is never fed to live stock, although it is excellent food.

Vetches flourish best in moist clay loam soils of free working texture. They will grow most satisfactorily in rich soils and will do as well in poor soils as an ordinary crop. The spring vetch should be sown for forage as early as the ground is dry enough to be worked without injury. The winter vetch ought to be sown long before winter to enable it to become firmly established that it may the better withstand the rigors of winter. There should be considerable moisture in the soil to

WHEAT.—This crop ranks third in the United States. It grows in cool, temperate and warm climates and in many kinds of soil. It does best in clay loam and poorest in sandy soil. The hard water-soaked lands will not grow wheat with profit to the farmer. For this reason, where good wheat production is desired, the soil must be well drained and in good physical condition—that is the soil must be open, crumbly and mellow.

Clay soils that are hard and lifeless can be made valuable for wheat production by covering the surface with manure, by good tilling and by a thorough system of crop rotation. Cowpeas make a most valuable crop to precede wheat, for in growing the atmospheric nitrogen is added to the soil, their roots loosen the root bed, thereby admitting a free circulation of air and add humus to the soil. Moreover, the cowpea leaves the soil in a compact condition so much desired in wheat production. One may secure a good seed bed after cotton, potatoes and corn as well as after peas. These are summer cultivated crops and the clean culture that has been given renders the top soil mellow and the under soil firm and compact. They are not so good, however, as cowpeas, since they add no atmospheric nitrogen to the soil, as all the legumes do.

How Deep to Sow.—Several things enter into the depth of sowing. The soil has something to do with it as well as the moisture; and then the levelness and the firmness of the seed bed must be considered also. A sandy soil will give better results from deep seeding than a clay soil. Then, too, the dry soil will stand deeper sowing than the wet soil. If the season is dry, a greater depth should be given the seed than if it is a season of

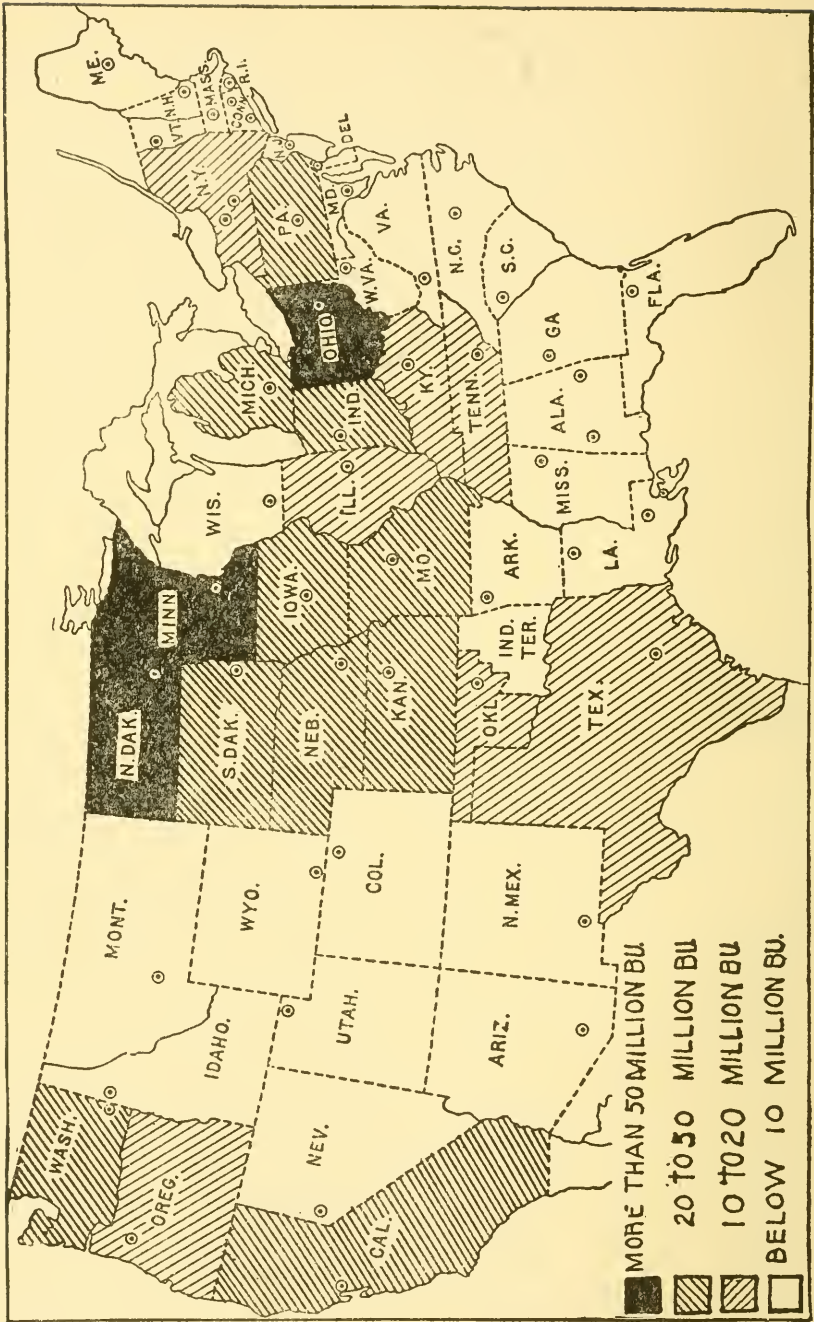

WHEAT PRODUCTION IN UNITED STATES

This map shows the production of wheat in 1900. The direction of the lines indicates the quantity produced.

continuous rainfall more or less. The depth varies all the way from 1 to 3 inches, but a practice usually followed by the farmers is to sow about 1 inch in depth, giving the seed this amount of moist soil for covering. Often the wheat field is cloddy and rough, and in cases of this kind a greater depth is desirable, not only to secure better germination, but also to give better covering.

When corn and potatoes are followed by wheat, a good depth is usually secured providing the disk-harrow has been run over once or twice previous to seeding. The potato bed ought always to provide an ideal seed bed. Often in corn land the weeds and hard surfaces make the bed unfit to start with, and too much seeding is done on this kind of land. Before seeding in cases of this nature a disking or double disking and even a cross disking is advisable. So given the grower is reasonably certain that the seed will be put deep enough in the soil to secure proper germination and to get the plant going rightly that it may pass through the winter without danger or injury. In case the soil is mellow, and loose, and the season more or less dry, a good rolling often will help out very much to start germination. If the rolling is done after seeding just as soon as the moisture begins to leave the soil run the peg-tooth harrow over the ground. This will make a mulch, the moisture in the soil will be held and the crop will push vigorously forward.

Fertilizing Wheat Lands.—Practically every form of fertilizer is applied to wheat lands. Some like raw bone meal, tankage and basic slag as carriers of phosphoric acid, because they feel these

materials are best for the grass crops that follow. Nitrate of soda as a source of nitrogen is excellent, but the best time for adding it is in the spring when vigorous growth will be secured in case the crop has gone through the winter poorly. When nitrate of soda is used in the fall, it is usually mixed

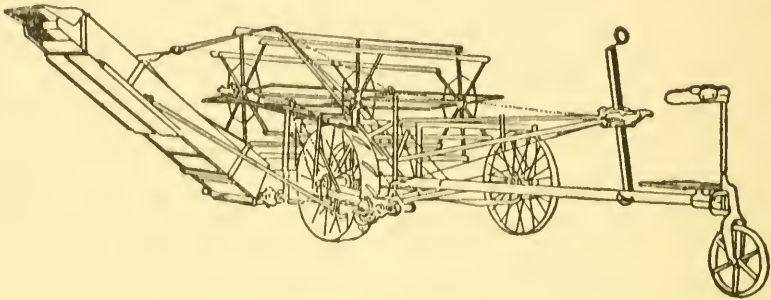

WHEAT HEADER

In some wheat districts the heads only are clipped off. These heads are carried by means of an elevator attached to the machine to the header boxes or wagons that travel along with the machine. When one wagon box is filled another replaces it. The detached heads are hauled to the storage place and stacked until threshing time. By using the header only a small part of the straw needs to be handled.

with other fertilizing materials. Muriate of potash is perhaps the cheapest source of potassium.

Whether to use factory mixed goods or complete fertilizers will depend upon circumstances. Some farmers have already tested their lands and know whether a complete fertilizer is needed or not. If wheat follows cowpeas or clover or any of the legumes, then it is certainly unnecessary to go to the expense of buying costly nitrogen when there is in all likelihood an abundance in the soil already. Then, too, some wheat soils are deficient in phosphorus, but possess an abundance of potassium. There is no need in this case of adding the potassium. If other lands are deficient in potassium but

relatively strong in phosphorus the latter can be omitted from the fertilizer mixture. The wheat grower must make a study of the soil and ascertain what elements are lacking in the soil and what carriers of the lacking ones are the best for supplying the deficiency.

Just how much fertilizer shall be used to the acre will depend also upon circumstances. In general, on average lands, from 15 to 20 pounds each of ammonia and potassium and from 25 to 50 pounds of phosphorus are desired. These amounts can be obtained by adding from 200 to 400 pounds of a commercial fertilizer containing about 4 per cent ammonia, 12 per cent of available phosphorus and 4 per cent of potassium. Many grades are on the market having analyses very similar to this and ordinarily can be obtained. It is advisable to add a reasonable quantity to the acre. Fertilizers pay best on lands well prepared. This should be more generally recognized than it is. Two methods of applying fertilizers are in vogue: To broadcast just before the seed drill; and in connection with seeding, the fertilizer attachment being attached to the seed drill. The latter method is most common because the expense is less.

Liming wheat land is good practice done judiciously. It helps the land, but if vegetable matter is not added from time to time soil humus will disappear and the land will suffer. All the way from 500 to 2,000 pounds may be added to the acre. The lime can be added by means of a lime distributor, or it can be thrown out in piles in the field and after slaking be scattered over the field with shovel, giving as even distribution as possible. It is advisable to apply the lime some days previous to

seeding and to harrow the lime in and not to allow it to remain on top of the soil for any length of time. Many lime users make a mistake in scattering the lime broadcast, allowing it to be carried down into the soil by rains. To get the full effect, harrow the lime into the soil.

Wheat should be grown in a rotation with other crops, and two of the best in such rotations are corn and clover. For instance, let corn follow clover; on the clover sod scatter the manure to be plowed under the corn; and following the corn should come the wheat. Some use oats after corn and wheat after oats. In this case, as soon after oat harvesting as possible, plow the land that a good seed bed may be had for the wheat later on. If the stable manure is added to the corn lands, then fertilizers will be more largely resorted to on the wheat lands. This plan is splendid and is used by many of the best wheat growers in sections where diversified farming has become established.

The Varieties Are Many.—Four types of wheat are recognized in the markets of the country. These types are the following: Soft winter wheat; hard winter wheat; hard spring wheat and white wheat. Included in the stock winter varieties are the Valley, Nigger, Mediterranean, Rudy, Fulcaster, Early Genessee Giant, Mealy, Early Ripe, Poole, Fultz, Harvest King and Dawson's Golden Chaff. The Fultz variety is probably more widely grown in the United States than any other. Among the hard winter varieties are Zimmerman, Turkey and Tasmanian Red. Fife and Blue Stem are the two leading types of hard spring wheat. Both are beardless and are grown in that immense wheat belt extend-

ing from Kansas north to Minnesota and the Dakotas. The varieties most popular on the Pacific coast are Australian, Oregon Red Chaff, Blue Stem, White Winter and Little Club.

In selecting a variety, it is well to try out those that do best near home and to study how they have done at the experiment station. By so acting you can choose a variety that will best serve you as a standby. If satisfied with your choice, improve it by selecting the seed wheat each year, using the seed plot to the full limit that the choicest heads and choicest grains may be saved to further improve the wheat stock.

Preparing the Land.—One of the real secrets of successful winter wheat culture is in this early preparation of the soil. Farmers have learned that ground for wheat should be plowed as soon as the previous crop has been removed and allowed to become compact before seeding time. It will not do, of course, to plow the ground and give it no further attention. It must be harrowed or disked often enough to keep down weeds and to keep the upper layers pulverized, forming a dust mulch which prevents the escape of valuable soil moisture. Where the ground is full of weed seed, this is a most excellent method of getting rid of these pests. The weed crop is prevented from seeding and the seed in the ground from last year germinates and the young plants are killed. Even such persistent perennials as cockle-burr, velvet leaf and jimson weed can finally be controlled. It may require two or three years of such treatment to get rid of the worst pests, but persistence will always result in success.

The ground for wheat should be carefully plowed; in most sections 5 to 7 inches deep. Every bit of

the ground must be stirred so that when drilling is done the seed will be covered evenly. The sulky plows or the modern gangs are best, as they do good work and completely cover all trash which may be on the surface. If plowing must be delayed until late on account of dry weather, or the fact that the crops growing on the land cannot be removed until just before seeding time, compacting must be done in some way. This is best accomplished by the use of a roller, drag, disk, smoothing harrow or some such implement. Neglect of this brings more poor wheat than any other one thing. Going over the ground two or three times is not sufficient. The work must be continued and, in some cases, the ground will have to be gone over four or five times.

Ideal Seed Bed for Wheat.—An ideal seed bed for wheat or other small seeds should not be mellow or loose to too great a depth, but rather the soil should be mellow and well pulverized only about as deep as the seed is planted. Below that depth the soil should be firm and well settled, making a good connection with the subsoil, so that the soil water stored in the subsoil may be drawn up into the surface soil. The firm soil below the seed, well connected with the subsoil, supplies moisture to the germinating seed and the young plantlet, while the mellow soil above the seed allows sufficient circulation of air to supply oxygen and favors the warming of the soil, gathering the heat of the sunshine during the day and acting as a blanket to conserve the soil heat, maintaining a more uniform temperature of the soil during the night. The mellow soil mulch above the seed conserves the soil moisture, acting as a mulch to keep the moisture from reaching the surface, where it would be

rapidly lost by evaporation. The same condition favors the growth of the young shoots upward into the air and sunshine.

The too loose, deep seed bed is almost wholly dependent upon sufficient rains to germinate the seed and start the young plants. In such a seed bed drouth is very apt to injure the plants, because of the rapid drying out of the soil to the depth of the plowing. In the loose seed bed the wheat is not only apt to burn out in summer, but it is also more apt to freeze out in winter, than wheat grown in the ideal seed bed as here described.

How Much Seed to Sow.—The amount of seed to the acre varies a little with the soil and the climate. As a rule, five pecks of well-cleaned seed will give a good stand and produce the maximum yield. If the seed is very expensive, one bushel will frequently answer. It is better, however, to be on the safe side and sow a little more than recommended rather than less. There are so many varieties that no one variety can be recommended for all sections of the wheat belt. The best guide is to get from the experiment station the kinds that have done best in the station tests. Then after consulting with the best wheat growers in your neighborhood, decide upon the kind. A good variety is always desirable, but do not forget that even the best seed will not do well on a poor seed bed.

Putting in the Seed.—Drilling is, of course, the only method to be recommended. The kind of a drill is another question. The modern disk drills have been so satisfactory that they can be recommended without hesitancy. The old-fashioned hoe drill is still used very widely and is a good implement. The press drill during a dry season is ex-

ceedingly satisfactory, but its heavy draft and the fact that it is not available in many neighborhoods, tend to keep it back. A number of the manufacturers of drills now make a combination implement, by means of which the press wheels may be used or not, depending upon the condition of the soil. This is a little more expensive than the average drill, but since you have two implements in one, it can be purchased with profit.

Saving Grain at Harvest.—It is a matter of small consequence if grain in the corners of the field is wasted or if the binder course at the edge of the field is destroyed, so we think—the hogs will get it. In many cases this is true. But it is expensive feeding, too expensive at the present price of grain. And the loss of grain in the shock and stack, due to mice, rats and bad weather, is much greater than the loss due to loss in the field. But is this loss all necessary? Is it good business to go to the expense of raising wheat or rye or oats, and then after the crop has matured to lose anywhere from 5 to 15 per cent of the crop by bad management at harvest? In many instances not only has the entire crop in the shock or stack been damaged, but a large amount, often as much as 25 per cent of the crop, has actually been destroyed. Every once in a while seasons are bad for the crops. They catch grain growers by surprise and to their loss. True as this may be, it is a fact, nevertheless, that many farmers, big and little, do circumvent the loss and damage. They do it by wise planning, by careful management and by meeting emergencies as they occur.

Making Shocks to Withstand Rain.—There is little to be said about stacking and shocking grain

in the field. In some seasons it makes little difference what sort of shock is set up, or whether set up at all. If a rainy period prevails a difference results, and a big difference. The plan of setting the bundles two by two, without caps, is a bad custom during rainy seasons. The heads being wholly exposed, a great number of kernels sprout, even grow if the showers are frequent and the weather hot. Wheat shocked in this manner is often practically ruined. Hasty shocking may pass as a rule, but there always comes a time when the loss is a severe penalty.

It is a good rule to set the shocks carefully with some permanency and then the risk of loss in the field will be much less. When the grain is fairly ripe, two sets of two bundles may be set with the tops leaning toward the center. About these are set other bundles; one on each end and two on each side, with two well-broken and flattened bundles on top for caps. So set, the shocks stand well, are firm and plenty of ventilation is possible for the grain and straw to dry out readily. Thus set, with caps well made and well placed, long periods of wet weather will be withstood without any injury to the grain.

Good Stack for Wheat.—The custom of threshing from the shock has been spreading for years. It has its advantages and disadvantages, all of which each grain grower knows and understands. The general art of stacking, because the custom of stacking is now not so universal, has become lost in some sections, and only the most indifferent makeshift sorts of stacking result as a consequence. Many stacks leak if heavy rains continue. The water goes down into the stack from the top, or is

beaten in from the sides, causing the grain to sprout, in many cases to rot, and in all cases to be severely damaged. Now this is bad and the evil should be corrected.

The method in stacking wheat or oats or other small grain is to make a stack that will not take water. The shape or the size is not of much consequence. The real art is to lay the bundles so skillfully that the rains will be kept out. Two general ideas prevail in laying the bundles: One is to start at the center and work from the center to the outer edge; the other is to work from the outer edge to the center. It does not make much difference which is followed, providing the center is kept high enough, that the drain, if there be any, may be down and out.

A good, old-tried method is to bring the stack up to some 4 or 5 feet in the center; lay down two or three bundles, so as to get a good pitch before working the outer edge. The idea from now on is to keep the center high and the outer edge low. The outward bundles can be given a little less pitch than those further in. Do not try to have the bundles so close together on the outer edge of the stack; give them plenty of room, so that when a stack settles the outer edge will settle and the center remain solid. In case the outer edge starts to slip, it can be quickly tied by working at the center and then from it toward the edge. By so doing the slip will be checked at once.

Another method of stacking is to stand the bundles up on their butts in the center of the stack. Press the bundles inward until the bottom is as large as needed, when the bundles should be laid down with the butts outward. Now a course on

the outer side is laid, and when completed another course is started in the opposite direction with the butts laying up to the bands. Course after course now follows until the middle is reached. The inner course should be packed very closely, so as to keep the middle fuller than the outside. A good stacker, who is accustomed to the work, will lay out a little until the stack is as large as needed. The size can be maintained until it is time to draw in so as to top out. It is especially necessary when this drawing-in work has started to have the center full, which must be maintained all the time. Keep the center higher than the outside. When the draw-in is started, let it be done slowly at first.

Small grains stacked in this manner will save the grain about as well as if stored in the barn. As a last thing, I like to cover the stack with old hay and then to weigh this down with hangers made of ropes or wires. When so protected it is just about impossible for rains to do any damage.

Threshing from Shock or Stack.—The strongest argument against threshing from the shock is the fact that it takes the whole farming force of the community with a great many teams to get the grain to the machines. If the farmer pays for most of this large force of helpers by working back, when his neighbors get ready to thresh it will take him a great many days to cancel his debt. No matter how pressing a certain piece of work may be he is obliged to break right off and assist his neighbor when the machine gets there. Threshing machines are like time itself—they wait for no man. A farmer is forced to thresh in his turn when the machine reaches his neighborhood, or he may have to wait a long while before it comes back to his

place. If grain is well stacked a farmer can be more independent and choose his time for threshing. But if not well stacked it is desirable to thresh as soon as possible, for if heavy rains set in much of the grain will be greatly damaged.

One successful way to thresh from the shock is for ten or a dozen farmers in one neighborhood to organize a club, get a machine and go to work immediately, threshing first for one man, then another until each man in his turn has been served. In this way help is paid back at once and the work is over.

Controlling the Hessian Fly.—This pest causes annually considerable loss in the wheat fields. Various remedies for its suppression have been suggested, but none of them is wholly satisfactory. To be effective, burning the stubble after the crop has been harvested must be done before the flies emerge from the pupal state. In case this plan is to be adopted, the wheat should be cut quite high, so that all the pupæ will remain in the stubble. The objection to this of course, is that some of the insects have been permitted to mature. Burning the screenings and chaff after threshing may lessen the number to some extent. Another plan is to turn under the stubble after the grain has been removed, plowing to a depth of several inches and rolling the ground. The pupæ in most cases will be destroyed.

The food supply for the insects during late summer and early autumn should be destroyed. The flies emerge during this period, and if the volunteer grain about the stack and in the field is not present eggs cannot be deposited. Destroy the volunteer grain by plowing or pasturing. Some farmers

early sow strips of wheat through the field. The insects as soon as they emerge deposit the eggs in these grain patches. As soon as the pupæ have formed the growing plants can be turned under and the flies killed. These strips should be sown very early. Possibly the best way of all is late sowing. Delay the seeding until the adult fly has emerged and perished. Of course the flies occasionally breed very late in the season, but if the farmers will watch their fields they will very often find that the entire brood has perished before it is too late to sow wheat. A combination of methods is probably the best. If the weather is dry, burn the stubble as soon as the grain is off. If it is wet plow it under, following with a roller, and as soon as any volunteer wheat appears turn it under. The chaff from the threshing machine should be burned. If strips of winter wheat are used as decoys, they must be plowed under at the end of three or four weeks. With these precautions and the planting of the crop at the latest practicable date, the ravages of the Hessian fly can be greatly lessened.

How Flour Is Made.—The wheat is first cleaned, tempered, tested and, if approved by the tester, it is ground by the gradual reduction method, which is a process of granulation rather than pulverization, as is the case of the upper and nether millstone. In this process it goes through six different sets of machines called breaks. This is the roller-mill process. The first break slightly crushes the wheat kernel when it goes to the scalper or sieve. Here the middlings, or grits, are separated. The residue is sent to another break, where it is crushed still more, carried to the scalper again, and more middlings sifted out. The wheat goes through

six different sets of breaks and a scalper each time, the rolls in each break being closer and closer together, and the middlings obtained in each instance being finer and finer.

This gives six different grades in size of particles. The finest and purest are selected for the best grade of flour, run through purifiers, where impurities are removed by suction and sifting. Dirt and dust are caught in a dust collector made of flannel tubes, when the residue is ground into flour, which is sometimes spoken of as bolting. Something like 150 separations are made from the time the wheat is turned into the hopper until it comes out in the sack labeled with the trade-mark of the particular mill grinding it.

WHITE CLOVER.—This little perennial is native to the northeastern United States and to Europe, but has been so long cultivated over the southern half of the United States that it is now thoroughly established. It is best adapted to rather moist soil, but will grow well on a large variety of soils, and under widely different climatic conditions. The seed should be sown in early spring. During the spring and early summer months, this clover makes its best growth. During the hottest part of the summer it remains practically stationary. It is able, however, to resist considerable drouth, although in the southern states it often disappears entirely during a period of protracted hot weather, only to reappear again abundantly when the conditions become favorable.

It is commonly used in this country for pasture and for lawns; always in combination with some other crop. It is ordinarily sown with blue grass, red top and some of the other smaller plants; more

so than the other clovers, and its yield is always very much less. For lawn and pasture purposes it is of great value because of its perennial character and its creeping habit, which enables it to closely cover the soil and occupy all the spaces left vacant by other plants. It furnishes tender, nutritious pasture and in lawns gives a close, dark-green, velvety growth. It flowers and fruits abundantly wherever it grows.

YELLOW CLOVER.—This plant is sometimes called black medic. At other times it is spoken of as trefoil, but this term is not sufficiently specific. Nor is it to be confounded with hop clover, although there is much of resemblance between the two plants. Yellow clover is perennial and recumbent in its habit of growth. It does not make sufficient growth to render it of much value for hay. But as a pasture plant it is, to some extent at least, deserving of a place in our agriculture. It bears seeds profusely, and as the season of bloom is prolonged when it is pastured, this plant has much power to reseed itself and therefore to maintain its hold upon land where it has been grown.

Yellow clover has special adaptation for soils well supplied with lime. On such soils it has in some localities almost assumed the character of a weed. But this can only happen in rainy climates. It will also grow in gravelly soils, where some of the other varieties of clover would fail. It grows freely in several of the Northern states. It is probable that it may be grown with more or less success in all, or nearly all, the tillable portions of the United States. Where other and superior kinds of clover will grow freely, it is not necessary to give much attention to yellow clover. But in permanent pas-

tures, even among superior sorts, it has a place, since it comes on early in the season and grows vigorously, and it is fine and leafy when young; but as summer advances it becomes woody and ceases to grow. As a pasture plant it is not the equal of white clover, but it may be able to grow in some situations where white clover will not succeed.

The seed of yellow clover is relatively cheap, hence to add 1 or 2 pounds of the seed to the acre to a mixture to be sown for permanent pasture will not add much to the whole cost of the seed. When sown alone, from 3 to 5 pounds of seed is ample. But it should only be thus sown to provide seed. The seed may be sown by hand or with some form of hand seeder, and covered with a light harrow or a roller, according to the character of the soil. When not sown to provide seed it ought to be made a part of a grass mixture rather than the sole crop. In such instances 1 or 2 pounds of seed to the acre should suffice.

Index

| | Page | | Page |
|-----------------------------------|---------|-----------------------------------|---------|
| Alfalfa | 95 | Cultivation, Gentle Art of..... | 23 |
| Alsike clover..... | 102 | Dairy Feeds, In Buying, Get | |
| Artichokes | 103 | Protein | 49 |
| Bad Drainage..... | 7 | Durum Wheat..... | 147 |
| Barley | 105 | Emmer | 148 |
| Beans..... | 107 | Experiment Station at Home.... | 11 |
| Beggar Weed..... | 44, 107 | Fanning Mills..... | 88 |
| Bermuda Grass..... | 108 | Farm Crops..... | 95 |
| Blue Grass..... | 109 | Feeding Stuffs, Home Raised.... | 46 |
| Breeding Up Farm Crops..... | 89 | Fertilizers, Function of..... | 8 |
| Broom Corn..... | 109 | Field Beans..... | 149 |
| Broom Corn Millet..... | 113 | Field Peas..... | 150 |
| Buckwheat | 113 | Flax | 151 |
| Bur Clover..... | 115 | Forage Crops..... | 54 |
| Canada Field Peas..... | 116 | German Millet..... | 152 |
| Carrots | 69, 116 | Good Silo, Essentials of..... | 70 |
| Cassava | 118 | Good Soils and Good Crops..... | 4 |
| Cattle Feeds..... | 44 | Grasses, Preparation of Land for | 20 |
| Chufa | 119 | Grasses, Seeding and Feeding... | 21 |
| Clover, Alsike..... | 102 | Grasses, The Growing of..... | 19 |
| Club Wheat..... | 120 | Grass Seed Sowing..... | 22 |
| Common Millet..... | 120 | Hairy Vetch..... | 152 |
| Common Red Clover..... | 120 | Harrow, When to Use..... | 32 |
| Corn | 121 | Helping Nature..... | 5 |
| Corn, Basis for Soiling..... | 80 | Hemp | 152 |
| Corn, Best Silage crop..... | 70 | Hogging off Corn..... | 133 |
| Corn Cultivator..... | 125 | Hops | 155 |
| Corn, Field Selection of Seed.... | 127 | Hungarian Millet..... | 156 |
| Corn for Summer..... | 67 | Inbreeding of Corn..... | 94 |
| Corn, Hogging off..... | 133 | Indian Corn..... | 156 |
| Corn Husking from Standing | | Italian Rye Grass | 156 |
| Stalks | 133 | Japan Clover..... | 156 |
| Corn Improved by Selection..... | 91 | Japanese Millet..... | 158 |
| Corn Kernels..... | 47 | Kafir Corn..... | 158 |
| Corn, Putting in Shocks..... | 131 | Kentucky Blue Grass..... | 160 |
| Corn Shocking by Machinery.... | 132 | Legumes, High Importance of 8, | 9 |
| Corn Smut..... | 87 | Legumes, The Work They Do... 59 | |
| Cotton | 136 | Lespedeza | 162 |
| Cotton, Helping Cotton Lands.... | 139 | Level Culture..... | 24 |
| Cotton, Improving Cotton..... | 85 | Lupines | 162 |
| Cottonseed Meal..... | 51 | Maize | 162 |
| Crimson Clover..... | 120 | Mammoth Clover..... | 162 |
| Crop Growing | 1 | Mangels | 70, 163 |
| Crops and Food Nutrients..... | 57 | Meadow Fescue..... | 165 |
| Crops and Line of Business..... | 55 | Meadow Foxtail..... | 166 |
| Crops for Feeding..... | 43 | Melilotus Alba..... | 166 |
| Crops for Succulence..... | 63 | Millets | 166 |
| Crops, Preparing for..... | 25 | Milo Maize..... | 169 |
| Cowpea Fertilizer..... | 13 | Moisture and Seed Bed..... | 29 |
| Cowpea Hay..... | 147 | Muskmelons | 170 |
| Cowpea Rack..... | 145 | Nitrogen, Storing Without Cost.. | 12 |
| Cowpeas | 143 | Oat Grass | 170 |
| Cowpea Shock..... | 146 | Oats..... | 170 |
| Cultivate, When to..... | 24 | Orchard Grass..... | 66, 178 |
| Cultivation | 38 | Pastures, Good Ones Popular... 64 | |

| | Page | | Page |
|--|------|-----------------------------------|---------|
| Peanuts | 179 | Silage, Crops for | 78 |
| Pearl Millet | 182 | Silage, Feeding Silage | 78 |
| Perennial Rye Grass | 182 | Silo, Calculating Size | 71 |
| Plant Breeding | 84 | Silo, Filling the | 71 |
| Plant Breeding, Keynote of | 85 | Silos | 75 |
| Plant Improvement, Laws of | 93 | Silos, Capacity of | 77 |
| Plants, Varying Need of | 17 | Soiling, Advantages of | 82 |
| Plowing, Early Plowing | 30 | Soiling Crops | 75, 79 |
| Polish Wheat | 182 | Soiling, Objections to | 83 |
| Potatoes | 183 | Soiling in Place of Pasture | 81 |
| Potato Yields Increasing | 10 | Soil Packing to Start Water | 28 |
| Poultard Wheat | 193 | Sorghum | 214 |
| Protein | 46 | Sowing Grass Seed | 22 |
| Protein, Home Production of | 56 | Soy Beans | 219 |
| Protein, Judgment in Purchase | 48 | Spelt | 221 |
| Pumpkins | 193 | Spurry | 222 |
| Rape | 194 | Succulent Crops | 63 |
| Rape for Supplementing Pastures | 65 | Sugar Beet | 224 |
| Red Clover | 197 | Sugar Cane | 228 |
| Red Top | 202 | Sunflower | 230 |
| Rescue Grass | 203 | Sweet Clover | 232 |
| Rice | 204 | Sweet Potato | 233 |
| Root Bed | 7 | Tall Fescue | 236 |
| Root Crops | 68 | Tall Oat Grass | 237 |
| Roots, Preserving in Pits | 73 | Teosinte | 238 |
| Rotation and Stability | 18 | Tillage and Fertilizers | 6 |
| Rotation for Soiling Crops | 81 | Timothy | 239 |
| Rotations, How to Help Out | 16 | Tobacco | 242 |
| Rutabagas | 207 | Turnips | 69, 247 |
| Rye | 209 | Velvet Bean | 249 |
| Rye Grass | 213 | Velvet Grass | 250 |
| Sanfoin | 213 | Vetches | 251 |
| Scarlet Clover | 214 | Water Saving | 25 |
| Seed Bed | 27 | Wheat | 253 |
| Seed Bed and Moisture | 29 | Wheat following Corn | 33 |
| Seed Bed Ideal for Small Seed | 36 | Wheat, Ideal Seed Bed for | 260 |
| Seed Beds, Good Ones not Disappointed | 28 | Wheat, Preparing for | 259 |
| Seed Corn Room | 90 | Wheat, Varieties of | 258 |
| Sheep's Fescue | 214 | White Clover | 268 |
| Shocking Corn | 124 | Yellow Clover | 269 |

OCT 6 1910

One copy del. to Cat. Div.

NOV 11 1940

LIBRARY OF CONGRESS



00026813980

