

THE
M I C R O S C O P E :
AND ITS REVELATIONS.

.

BY THE SAME AUTHOR.



I.

HUMAN PHYSIOLOGY.

Illustrated with numerous Engravings on Wood.

Fifth Edition, 8vo. cloth, 26s.

II.

COMPARATIVE PHYSIOLOGY.

Illustrated with 300 Engravings on Wood.

Fourth Edition, 8vo. cloth, 24s.

III.

A MANUAL OF PHYSIOLOGY.

With numerous Illustrations on Steel and Wood.

Second Edition, Fcap. 8vo. cloth, 12s. 6d.

THE
'MICROSCOPE:

AND ITS

REVELATIONS,

BY

WILLIAM B. CARPENTER, M.D., F.R.S., F.G.S.

EXAMINER IN PHYSIOLOGY AND COMPARATIVE ANATOMY IN THE UNIVERSITY
OF LONDON,

PROFESSOR OF MEDICAL JURISPRUDENCE IN UNIVERSITY COLLEGE,
PRESIDENT OF THE MICROSCOPICAL SOCIETY OF LONDON



Illustrated by 345 Wood Engravings.

LONDON:
JOHN CHURCHILL, NEW BURLINGTON STREET.

M D C C C L V I.

[The Author reserves to himself the right of Translation.]

LONDON :
SAVILL AND EDWARDS, PRINTERS, CHANDOS-STREET,
COVENT GARDEN.

P R E F A C E.

THE rapid increase which has recently taken place in the use of the Microscope,—both as an instrument of scientific research, and as a means of gratifying a laudable curiosity and of obtaining a healthful recreation,—has naturally led to a demand for information, both as to the mode of employing the instrument and its appurtenances, and as to the objects for whose minute examination it is most appropriate. And as none of the existing Treatises, either British or Foreign, on the Microscope and its Uses, have seemed to the Author fully adapted to meet this demand (some of them being almost exclusively concerned with the Microscope itself, and others with some special branch or branches of Microscopic study), he has felt encouraged to carry-out a plan which he had formed several years since; by endeavouring to combine, within a moderate compass, that information in regard to the use of his ‘tools’ which is most essential to the working Microscopist, with such an account of the objects best fitted for his study, as might qualify him to comprehend what he observes, and might thus prepare him to benefit science, whilst expanding and refreshing his own mind.

In his account of the various forms of Microscopes and Accessory Apparatus, the Author has not attempted to describe everything which is in use in this country;

'still less, to go into details respecting the construction of foreign instruments. He is satisfied that in all which relates both to the mechanical and the optical arrangements of their instruments, the chief English Microscope-makers are decidedly in advance of their Continental rivals; and on this point he speaks not only from his own conviction, but from the authority of a highly-accomplished German Microscopist, who has recently visited London for the express purpose of making the comparison. Even among the products of English skill, it was necessary for him to make a selection; and he trusts that he will be found to have done adequate justice to all those, who have most claim to an honourable mention.

In treating of the Applications of the Microscope, the Author has constantly endeavoured to meet the wants of those, who come to the study of the minute forms of Animal and Vegetable life with little or no previous scientific preparation, but who desire to gain something more than a mere *sight* of the objects to which their observation may be directed. Some of these may perhaps object to the general tone of his work as too highly-pitched, and may think that he might have rendered his descriptions simpler by employing fewer scientific terms. But he would reply to such, that he has had much opportunity of observing, among the votaries of the Microscope, a desire for such information as he has attempted to convey (of the extent of which desire, the success of the "Quarterly Journal of Microscopical Science" is a very gratifying evidence); and that the use of scientific terms cannot be dispensed with, since there are no others in which the facts can be expressed. As he has made a point of explaining these, in the places where they are first introduced, he

cannot think that any of his readers need find much difficulty in apprehending their meaning.

The proportion of space allotted to the various departments, has been determined not so much by their Physiological importance, as by their special interest to the Microscopist; and the remembrance of this consideration will serve to account for much that might otherwise appear strange. The Author has thought it particularly needful to restrain himself, in treating of certain very important subjects which are fully discussed in treatises expressly devoted to them (such, for example, as the structure of Insects, and the Primary Tissues of Vertebrata), in order that he might give more space to those on which no such sources of information are readily accessible. For the same reason, he has omitted all reference to the applications of the Microscope to Pathological inquiry; a subject which would interest only one division of his readers, and on which it would have been impossible for him to compress, within a sufficiently-narrow compass, a really-useful summary of what such readers can readily learn elsewhere. So again, the application of the Microscope to the detection of Adulterations in Food, &c., is a topic of such a purely-special character, and must be so entirely based on detailed descriptions of the substances in question, that he has thought it better to leave this also untouched.

It has been the Author's object throughout, to guide the possessor of a Microscope to the *intelligent* study of any department of Natural History, that his individual tastes may lead him to follow-out, and his particular circumstances may give him facilities for pursuing. And he has particularly aimed to show, under each head, how small is the amount of reliable know-

ledge already acquired, compared with that which remains to be attained by the zealous and persevering student. Being satisfied that there is a large quantity of valuable *Microscope-power* at present running to waste in this country,—being applied in such desultory observations as are of no service whatever to science, and of very little to the mind of the observer,—he will consider the labour he has bestowed upon the production of this Manual as well repaid, if it should tend to direct this power to more systematic labours, in those fertile fields which only await the cultivator to bear abundant fruit.

In all that concerns the *working* of the Microscope, the Author has mainly drawn upon his own experience, which dates-back almost to the time when Achromatic Object-glasses were first constructed in this country. He would be ungrateful, however, if he were not to acknowledge that he has derived many valuable hints from the Practical Treatises of Mr. Quekett and Dr. Beale, and from the Micrographic Dictionary of Messrs. Griffith and Henfrey. And among the works by which he has been specially aided in treating of the Applications of the instrument, he would especially name Mr. Quekett's valuable Lectures on Histology (Vegetable and Animal), Mr. Ralfs's beautiful Monograph on the British Desmidiæ, Prof. W. Smith's on the Diatomaceæ (which will, when complete, be quite worthy to take rank with the preceding), and the Micrographic Dictionary.

All the Illustrations have been drawn by Mr. W. Bagg, and have been engraved under his superintendence; and the Author ventures to affirm, that for fidelity as well as for beauty of execution, they will bear comparison with any Microscopic delineations yet executed on

wood. A large proportion of the subjects are original; the sources of all that are not so, are specified in the list (p. xv).

The Author feels that some apology is due for the long delay which has attended the appearance of this work. When it was first announced as forthcoming, his full intention was to apply himself immediately to its production; but the unexpected demand for new editions of his two large Treatises on Physiology, required that the whole of his disposable time and attention should be given-up during two years to carrying these through the press. When he at last found himself free to apply himself to the "Microscope," he fully expected that the forward state of his preparations would enable him to complete it by October, 1855. But in this expectation he has been disappointed by the occurrence of two severe attacks of indisposition, which compelled him for a time to suspend all mental exertion, and have rendered it necessary for him carefully to abstain from overtaking himself; so that he feels assured that those who have kindly waited for the appearance of this volume, will not, when acquainted with these circumstances, blame him for a delay, the causes of which have lain so completely beyond his control.

UNIVERSITY HALL, LONDON,
Feb. 9, 1856.

TABLE OF CONTENTS.

INTRODUCTION.

History of the Microscope and of Microscopic Research	PAGE 1
---	-----------

CHAPTER I.

Optical Principles of the Microscope	38
--	----

CHAPTER II.

CONSTRUCTION OF THE MICROSCOPE.

General Principles	66	Compound Microscopes—	
Simple Microscopes	70	Nacht's	84
Ross's	71	Smith and Beck's Student's	87
Gardner's	73	Do. Dissecting	89
Field's	75	Warrington's Universal	91
Quekett's	77	Ross's	95
Compound Microscopes	79	Powell and Lealand's	99
Field's	80	Smith and Beck's	101
Highley's	83	Nacht's Binocular	104

CHAPTER III.

ACCESSORY APPARATUS.

Draw-Tube	108	Reflecting Prisms	127
Erector	109	White-Cloud Illuminator	128
Micrometer	110	Oblique Illuminators	129
Goniometer	115	Black-Ground Illuminators	132
Indicator	115	Polarizing Apparatus	135
Camera Lucida	116	Illuminators for Opaque Objects	138
Object-Glass-Holder	118	Stage-Forceps	143
Object-Marker	119	Glass Stage-Plate	144
Lever Stage	120	Aquatic Box	145
Object-Finder	121	Zoophyte Trough	146
Magnetic Stage	123	Compressorium	148
Diaphragm-Plate	123	Dipping-Tubes	150
Achromatic Condenser	124	Forceps	151

CHAPTER IV.

MANAGEMENT OF THE MICROSCOPE.

Support	153	Arrangement for Opaque Ob-	
Light	154	jects	178
Position of Light	157	Errors of Interpretation	184
Care of the Eyes	158	Comparative Values of Object-	
Care of the Microscope	158	Glasses; Test-Objects	191
General Arrangements	160	Determination of Magnifying	
Arrangement for Transparent		Power	2
Objects	169		

CHAPTER V.

PREPARATION, MOUNTING, AND COLLECTION OF OBJECTS.

Microscopic Dissection	p. 104	Mounting Objects in Canada	
Cutting Sections of Soft Sub-		Balsam	p. 236
stances	212	Preservative Fluids	244
Cutting Sections of Harder Sub-		Mounting Objects in Fluid	247
stances	213	Cement-Cells	249
Grinding and Polishing of Sec-		Thin-Glass Cells	250
tions	215	Plate-Glass and Shallow Cells	251
Chemical Actions	220	Deep and Built-up Cells	252
Glass Slides	224	Mounting Objects in Cells	255
Thin Glass	224	Importance of Cleanliness	257
Varnishes and Cements	227	Labelling and Preserving of	
Mounting Objects Dry	232	Objects	258
		Collection of Objects	259

CHAPTER VI.

MICROSCOPIC FORMS OF VEGETABLE LIFE.—PROTOPHYTES.

Boundary between Animal and		Ulvaceæ	343
Vegetable Kingdoms	262	Oscillatoriaceæ	346
Characters of Vegetable Cell	264	Siphonaceæ	348
Life-History of Simplest Proto-		Confervaceæ	352
phytes	266	Conjugatææ	355
Volvocineæ	277	Charophoraceæ	357
Desmidiaceæ	285	Batrachospermeæ	358
Diatomaceæ	300	Characeæ	359
Palmellaceæ	340		

CHAPTER VII.

MICROSCOPIC STRUCTURE OF HIGHER CRYPTOGAMIA.

Alge	365	Mosses	392
Lichens	373	Ferns	394
Fungi	374	Equisetaceæ	405
Hepaticæ	387		

CHAPTER VIII.

MICROSCOPIC STRUCTURE OF PHANEROGAMIC PLANTS.

Elementary Tissues	408	Structure of Cuticle and Leaves	443
Structure of Stem and Root	428	Structure of Flowers	451

CHAPTER IX.

MICROSCOPIC FORMS OF ANIMAL LIFE:—PROTOZOA; ANIMALCULES.

Protozoa	463	Infusoria	473
Rhizopoda	470	Rotifera	490

CHAPTER X.

FORAMINIFERA, POLYCYSTINA, AND SPONGES.

Foraminifera	502	Sponges	523
Polycystina	519		

CHAPTER XI.

ZOOPLHYTES.

Hydra	p. 528	Acalephæ	p. 540
Hydrozoa	532	Anthozoa	547

CHAPTER XII.

ECHINODERMATA.

Structure of Shell and Spines	553	Echinoderm-Larvæ	565
---	-----	----------------------------	-----

CHAPTER XIII.

POLYZOA AND COMPOUND TUNICATA.

Polyzoa	571	Compound Tunicata	581
-------------------	-----	-----------------------------	-----

CHAPTER XIV.

MOLLESCOUS ANIMALS GENERALLY.

Shells of Mollusca	589	Ciliary motion on Gills	615
Tongues of Gasteropods	603	Organs of Sense of Mollusks	615
Development of Gasteropods	608	Chromatophores of Cephalopods	617

CHAPTER XV.

ANNULOSA OR WORMS.

Entozoa	618	Annelida	625
Turbellaria	623		

CHAPTER XVI.

CRUSTACEA.

Pycnogonida	630	Cirripedia	641
Entomostraca	633	Shell of Decapoda	643
Suctoria	640	Metamorphosis of Decapoda	644

CHAPTER XVII.

INSECTS AND ARACHNIDA.

Great number and Variety of		Wings	673
Objects afforded by Insects	647	Feet	676
Structure of Integument	649	Stings and Ovipositors	678
Tegumentary Appendages	650	Eggs	680
Parts of the Head	657		
Circulation of the Blood	667	Acarida	682
Respiratory Apparatus	668	Parts of Spiders	684

CHAPTER XVIII.

VERTEBRATED ANIMALS.

Primary Tissues	p. 686	Epidermis	p. 711
Bone	687	Pigment-Cells	712
Teeth	691	Epithelium	713
Scales of Fish	694	Fat	715
Hairs	698	Cartilage	716
Feathers	702	Glands	718
Hoofs, Horns, &c.	703	Muscle	719
Blood	704	Nerve	723
White and Yellow Fibres.	708	Circulation of the Blood	726
Skin, Mucous, and Serous Membranes	711	Injected Preparations	730
		Vessels of Respiratory Organs	735

CHAPTER XIX.

APPLICATIONS OF THE MICROSCOPE TO GEOLOGY.

Fossilized Wood, Coal	740	Organic materials of Rocks	755
Fossil Foraminifera, Chalk	743	Structure of Fossil Bones,	
Nummulites	749	Teeth, &c.	757
Orbitoides	753		

CHAPTER XX.

INORGANIC OR MINERAL KINGDOM.—POLARIZATION.

Mineral objects	761	Objects suitable for Polari- scope	763
Crystallization of Salts	762		

LIST OF ILLUSTRATIONS.

	PAGE
1. Refraction of parallel rays by plano-convex lens	40
2. Ditto by double-convex lens	41
3. Refraction of Converging rays	42
4. Refraction of Diverging Rays	42
5. Formation of images by Convex lenses	44
6. Spherical Aberration	45
7. Chromatic Aberration	48
8. Section of Achromatic Object-glass	51
9. Effect of Covering-glass	52
10. Action of Simple Microscope	55
11. Simplest form of Compound Microscope	60
12. Complete Compound Microscope	60
13. Huygheman Eye-piece	62
14. Ross's Simple Microscope	72
15. Gairdner's Simple Microscope	74
16. Field's Simple Microscope	76
17. Quekett's Dissecting Microscope	77
18. Field's Compound Microscope	81
19. Hughley's Hospital Microscope	83
20. Nает's Compound Microscope	85
21. Smith and Beck's Student's Microscope	87
22. Ditto Dissecting Microscope	90
23. Warington's Universal Microscope	91
24. Ditto Ditto	92
25. Ditto Ditto	93
26. Ditto Ditto	94
27. Ross's Large Compound Microscope	96
28. Powell and Lealand's Ditto	99
29. Smith and Beck's Ditto	102
30. Arrangement of Binocular Prisms	105
31. Nает's Binocular Microscope	106
32. Draw-tube with Erector	109
33. Jackson's Eye-piece Micrometer	113
34. Microscope arranged for Drawing	116
35. Ross's Achromatic Condenser	126
36. Smith and Beck's Ditto	126
37. Powell and Lealand's Ditto	127
38. White-Cloud Illuminator	128
39. Amic's Prism	131
40. Parabolic Illuminator	134
41. Fitting of Polarizing Prism	136
42. Fitting of Analysing Prism	136
43. Selenite Object-Carrier	137
44. Bull's-Eye Condenser	139
45. Ordinary Condensing Lens	140
46. Side Reflector	141
47. Stage-Forceps	143
48. Aquatic Box	145

	PAGE
49. Zoophyte-Trough	147
50. Compressorium	148
51. Dipping-Tubes	150
52. Forceps	151
53. Section of Adjusting Object-glass	166
54. Arrangement of Microscope for Transparent Objects	171
55. Ditto Ditto Opaque Objects	180
56. Spring Scissors	210
57. Curved Scissors	212
58. Valentin's Knife	213
59. Section-Instrument	214
60. Lever of Contact	226
61. Slider-Forceps	233
62. Spring-Press	239
63. Turn-Table	249
64. Plate-Glass Cells	252
65. Tube-Cells	253
66. Built-up Cells	254
67. <i>Palmella macrococca</i> , after Braun	268
68. <i>Protococcus pluvialis</i> , after Cohn	272
69. <i>Volvox globator</i> , after Ehrenberg	277
70. Development of <i>Volvox</i> , after Williamson	281
71. Various species of <i>Staurastrum</i> , after Ralfs	286
72. <i>Closterium lunula</i> , after S. G. Osborne	288
73. Development of <i>Pediastrum granulatum</i> , after Braun	292
74. Various forms of <i>Pediastrum</i> , after Ralfs	294
75. Conjugation of <i>Cosmarium botrytis</i> , after Ralfs	296
76. Ditto of <i>Closterium</i> , after Ralfs	297
77. <i>Didymoprium Grecillus</i> , after Ralfs	298
78. Portion of <i>Isthmia nervosa</i> , after Smith	304
79. <i>Triceratium foveus</i> , after Smith	305
80. <i>Pleurosigma angulatum</i> , after Wenham	307
81. <i>Biddulphia pulchella</i> , after Smith	308
82. Conjugation of <i>Eunotia</i> , after Thwaites	311
83. Conjugation of <i>Aulacoseira</i> , after Thwaites	312
84. <i>Actinocyclus undulatus</i> , after Smith	316
85. <i>Helopelta</i>	317
86. <i>Arachnoidiscus Ehrenbergii</i> , after Smith	319
87. <i>Campylodiscus costatus</i> , after Smith	320
88. <i>Sarirella contracta</i> , after Smith	321
89. <i>Gomphonema geminatum</i> , after Smith	323
90. Ditto, more highly magnified, after Smith	324
91. <i>Licmophora subellata</i> , after Smith	325
92. <i>Meridion circulare</i> and <i>Bacillaria paradoxa</i> , after Smith	326
93. <i>Achnanthes longipes</i> , after Smith	327
94. <i>Diatoma vulgare</i> , after Smith	328
95. <i>Grammatophora serpentina</i> , after Smith	328
96. <i>Isthmia nervosa</i> , after Smith	329
97. <i>Meloseira subflexilis</i> , after Smith	330
98. <i>Meloseira varians</i> , after Smith	330
99. <i>Mastogloia Smithii</i> , after Smith	331
100. <i>Mastogloia lanceolata</i> , after Smith	331
101. Fossil <i>Diatomaceæ</i> from Oran, after Ehrenberg	334
102. Fossil <i>Diatomaceæ</i> from Mourne mountain, after Ehrenberg	336
103. <i>Hæmatococcus sanguineus</i> , after Hassal	341
104. Development of <i>Ulva</i> , after Kutzing	343
105. Zoospores of <i>Ulva</i> , after Thuret	344
106. Zoospores of <i>Achlya</i> , after Unger	351
107. Cell-multiplication of <i>Conferva</i> , after Mohl	353
108. <i>Zygnema quininum</i> , after Kutzing	356
109. <i>Chatophora elegans</i> , after Thuret	357

	PAGE
110. <i>Batrachospermum moniliforme</i>	359
111. <i>Nitella flexilis</i> , after Slack	360
112. Antheridia of <i>Chara</i> , after Thuret	363
113. <i>Mesogloia vermicularis</i> , after Payer	366
114. <i>Sphaecelaria cirrhosa</i>	367
115. Receptacle of <i>Fucus</i> , after Thuret	368
116. Antheridia and antherozoids of <i>Fucus</i> , after Thuret	369
117. Tetraspores of <i>Carpocaulon</i> , after Kutzing	372
118. <i>Torula Cerevisia</i> , after Mandl	375
119. <i>Sarcina ventriculi</i> , after Robin	376
120. <i>Botrytis basiana</i> , after Robin	378
121. <i>Enterobryus spiralis</i> , after Leidy	379
122. Structure of <i>Enterobryus</i> , after Leidy	380
123. Fungoid Vegetation from <i>Pussulus</i> , after Leidy	381
124. <i>Styxanus caput-medusae</i> , after Payer	383
125. <i>Puccinia graminis</i>	384
126. <i>Ecidium tassilapinus</i> , after Payer	386
127. <i>Clavaria crispula</i> , after Payer	386
128. Fructification of <i>Marchantia</i> , after Payer	388
129. Stomata of <i>Marchantia</i> , after Mirbel	389
130. Conceptacles of <i>Marchantia</i> , after Mirbel	390
131. Archegonia of <i>Marchantia</i> , after Payer	391
132. Elater and spores of <i>Marchantia</i> , after Payer	392
133. Portion of Leaf of <i>Sphagnum</i>	393
134. Structure of <i>Mosses</i> , after Jussieu	394
135. Antheridia and antherozoids of <i>Polytrichum</i> , after Thuret	395
136. Mouth of Capsule of <i>Funaria</i>	396
137. Peristome of <i>Fontinalis</i> , after Payer	397
138. Ditto of <i>Bryum</i> , ditto	397
139. Ditto of <i>Cinclidium</i> , ditto	397
140. Petiole of <i>Fern</i>	398
141. Sorus of <i>Polypodium</i> , after Payer	399
142. Ditto of <i>Harmonitis</i> , ditto	400
143. Sorus and Inclusion of <i>Aspidium</i>	401
144. Ditto of <i>Debaria</i> , after Payer	401
145. Development of Prothallium of <i>Pteris</i> , after Suminski	402
146. Antheridia and antherozoids of <i>Pteris</i> , after Suminski	403
147. Archegonium of <i>Pteris</i> , after Suminski	404
148. Spores of <i>Equisetum</i> , after Payer	406
149. Section of leaf of <i>Agave</i> , after Hartig	409
150. Section of <i>Arata</i> (rice-paper)	410
151. Stellate Parenchyma of <i>Rush</i>	411
152. Cubical parenchyma of <i>Naphar</i>	411
153. Circulation in hairs of <i>Trudescantia</i> , after Slack	416
154. Testa of <i>Star-Anise</i>	417
155. Section of <i>Cherry-stone</i>	418
156. Section of <i>Coquilla-nut</i>	418
157. Spiral cells of <i>Oncidium</i>	419
158. Spinal fibres of <i>Collomia</i>	419
159. Cells of <i>Peony</i> , filled with starch	420
160. Starch-grains, under polarized light	421
161. Glandular fibres of <i>Coniferous Wood</i>	424
162. Vascular tissue of <i>Italian Reed</i> , after Schleiden	428
163. Transverse Section of stem of <i>Palm</i>	429
164. Ditto of <i>Wanghie Cane</i>	430
165. Ditto of <i>Clematis</i>	431
166. Ditto of <i>Cedar</i>	432
167. Ditto of <i>Buckthorn</i>	433
168. Ditto Ditto more highly magnified	433
169. Ditto of <i>Hazel</i>	434
170. Ditto of <i>Fossil Conifer</i>	435

	PAGE
171. Vertical section of <i>Fossil Conifer</i> , radial	435
172. Ditto	435
173. Ditto of <i>Mahogany</i>	436
174. Transverse Section of Fossil Wood	437
175. Vertical Section of Ditto	437
176. Transverse Section of Fossil Wood	438
177. Vertical Section of Ditto	438
178. Transverse Section of <i>Arctotochua</i> (?)	440
179. Ditto of <i>Burdock</i>	440
180. Cuticle of <i>Yucca</i>	443
181. Ditto of <i>Indian Corn</i>	443
182. Ditto of <i>Apple</i> , after Brongniart	444
183. Ditto of <i>Rochea</i> , Ditto	445
184. Vertical Section of leaf of <i>Rochea</i> , after Brongniart	448
185. Cuticle of <i>Iris</i> , Ditto	448
186. Vertical section of leaf of <i>Iris</i> , Ditto	449
187. Longitudinal section of ditto, Ditto	450
188. Cuticle of Petal of <i>Geranium</i>	452
189. Pollen-grains of <i>Allhæa</i> , &c.	456
190. Seeds of <i>Poppy</i> , &c.	460
191. <i>Amœba princeps</i> , after Ehrenberg	465
192. <i>Actinophrys sol</i> , after Clarapède	467
193. Various forms of <i>Rhizopods</i> , after Ehrenberg	471
194. <i>Kerona niurus</i> , after Milne-Edwards	475
195. <i>Paramecium caudatum</i> , Ditto	475
196. Group of <i>Vorticella</i> , after Ehrenberg	477
197. Fissionary Multiplication of <i>Chilodon</i> , after Ehrenberg	480
198. Metamorphoses of <i>Vorticella</i> , after Stein	482
199. Ditto of <i>Trichoda</i> , after Haime	483
200. <i>Brachionus pala</i> , after Milne-Edwards	491
201. <i>Rotifer vulgaris</i> , after Ehrenberg	493
202. <i>Stephanoceros fuchorni</i> , Ditto	498
203. <i>Noteus quadricornis</i> , Ditto	500
204. <i>Gromia oviformis</i> , after Schulze	504
205. <i>Rosalina ornata</i> , after Schulze	506
206. <i>Orbitolites complanatus</i>	508
207. Animal of simple type of ditto	510
208. Animal of complex type of ditto	512
209. Section of <i>Faujasma</i> , after Williamson	516
210. <i>Podocyrthus Schomburgku</i> , after Ehrenberg	520
211. <i>Rhopalocanium ornatum</i> , Ditto	520
212. <i>Halomma Humboldtii</i> , Ditto	520
213. <i>Perichlamydeum prætextum</i> , Ditto	520
214. <i>Polycystina</i> from Barbadoes, Ditto	521
215. <i>Stylocycta gracilis</i> , Ditto	522
216. <i>Astromma Aristotelis</i> , Ditto	522
217. Structure of <i>Grantia</i> , after Dobie	523
218. Portion of <i>Halichondria</i>	525
219. Siliceous spicules of <i>Pachymatisma</i>	526
220. <i>Hydra fusca</i> , after Milne-Edwards	529
221. Ditto in gemmation, after Trembley	531
222. Medusa-buds of <i>Syncoryna</i> , after Sars	534
223. <i>Campanularia gelatinosa</i> , after Van Beneden	537
224. <i>Sertularia cupressina</i> , after Johnston	539
225. <i>Thaumantias pilosella</i> , after E. Forbes	541
226. Development of <i>Medusa-buds</i> , after Dalyell	542
227. Development of <i>Medusa</i> , Ditto	543
228. <i>Cydippe</i> and <i>Beroe</i> , after Milne-Edwards	545
229. <i>Noctiluca miliaris</i> , after Quatrefages	546
230. Spicules of <i>Alcyonium</i> and <i>Gorgonia</i>	548
231. Ditto of <i>Gorgonia guttata</i>	548

	PAGE
232. Spicules of <i>Muricea elongata</i>	548
233. Puffierous capsules of <i>Actinia</i> , &c., after Gosse	551
234. Section of Shell of <i>Echinus</i>	554
235. Calcareous reticulation of Spine of <i>Echinus</i>	554
236. Ambulacral disk of <i>Echinus</i>	555
237. Transverse section of Spine of <i>Acrocladia</i>	556
238. Spines of <i>Spatangus</i>	558
239. Calcareous skeleton of <i>Astrophyton</i>	559
240. Ditto of <i>Holothuria</i>	563
241. Ditto of <i>Synapta</i>	564
242. Ditto of <i>Chirodota</i>	564
243. Bipinnarian larva of <i>Star-fish</i> , after Muller	566
244. Pluteus-larva of <i>Echinus</i> , after Muller	568
245. Cells of <i>Lepratiæ</i> , after Johnston	572
246. <i>Laguncula repens</i> , after Van Beneden	573
247. Bird's-head processes of <i>Cellularia</i> and <i>Bugula</i> , after Johnston and Busk	579
248. <i>Amaronium proliferum</i> , after Milne-Edwards	583
249. <i>Botryllus violaceus</i> , Ditto	584
250. <i>Perophora</i> , after Lister	585
251. Transverse Section of <i>Pinna</i>	590
252. Membranous basis of Ditto	590
253. Vertical Section of Ditto	591
254. Oblique Section of Ditto	592
255. Section of Imbge-tooth of <i>Mya</i>	593
256. Nacre of <i>Avicula</i>	594
257. Tubular shell-structure of <i>Anomia</i>	597
258. Vertical Section of shell of <i>Umo</i>	597
259. Internal surface of shell of <i>Terebratula</i>	599
260. External Ditto Ditto	599
261. Vertical Sections of Ditto	599
262. Horizontal Section of shell of <i>Terebratula bullata</i>	600
263. Ditto Ditto of <i>Megerlia lima</i>	600
264. Ditto Ditto of <i>Spiriferina rostrata</i>	600
265. Palate of <i>Helix hortensis</i>	604
266. Ditto of <i>Zonites cellarius</i>	604
267. Ditto of <i>Trochus zephyrinus</i>	606
268. Ditto of <i>Doris tuberculata</i>	606
269. Ditto of <i>Buccinum</i> , under polarized light	608
270. Embryoes of <i>Nudibranchs</i> , after Alder and Hancock	610
271. Embryonic development of <i>Purpura</i>	611
272. Later stages of the same	613
273. Structure of <i>Polycelis</i> , after Quatrefages	624
274. Circulation of <i>Terebella</i> , after Milne-Edwards	626
275. <i>Ammonothea pycnogonoides</i> , after Quatrefages	631
276. <i>Cyclops quadricornis</i> , after Paired	635
277. Development of <i>Balanus</i> , after Bate	642
278. Metamorphoses of <i>Caracus</i> , after Couch	645
279. Scale of <i>Morpho Menelaus</i>	652
280. Battledoor scale of <i>Polyommatus argus</i> , after Quekett	653
281. Scales of <i>Podura plumbea</i>	654
282. Hairs of <i>Myrmapod</i> and <i>Dermestes</i>	655
283. Head and Eyes of <i>Bee</i>	657
284. Section of Eye of <i>Melolontha</i> , after Strauss-Durckheim	658
285. Antenna of <i>Cockchafer</i>	661
286. Portions of ditto more highly magnified	662
287. Tongue of <i>Fly</i>	663
288. Tongue &c. of <i>Honey Bee</i>	664
289. Proboscis of <i>Vanessa</i>	666
290. Tracheal system of <i>Nepa</i> , after Milne-Edwards	669
291. Tracheæ of <i>Dytiscus</i>	670

	PAGE
292. Spiracle of <i>Fly</i>	671
293. Spiracle of Larva of <i>Cockchaffer</i>	672
294. Hook of <i>Fly</i> , after Hepworth	677
295. Hook of <i>Drosophila</i>	678
296. Keys of <i>Limulus</i> , after Burmeister	681
297. Foot, with comb of <i>Spider</i>	681
298. Ordinal and luminous threads of <i>Spider</i>	685
299. Minute structure of Bone, after Wilson	688
300. Edge of Bone, highly magnified, after Mandl	688
301. Section of bony scale of <i>Lepidosteus</i>	689
302. Vertical section of Tooth of <i>Lamna</i> , after Owen	691
303. Ditto of <i>Pristis</i> , ditto	691
304. Ditto of <i>Myliobates</i>	692
305. Vertical section of Human Tooth, after Mandl	693
306. Portion of Skin of <i>Sole</i>	695
307. Scale of <i>Sole</i>	696
308. Hair of <i>Musk-Deer</i>	699
309. Hair of <i>Sable</i>	699
310. Hairs of <i>Squirrel</i> and <i>Indian Bat</i>	699
311. Transverse section of Hair of <i>Pecari</i>	700
312. Structure of <i>Human Hair</i> , after Wilson	701
313. Transverse section of Horn of <i>Rhinoceros</i>	704
314. Blood-corpuscles of <i>Frog</i> , after Donn�	705
315. Ditto of <i>Man</i> , Ditto	705
316. Fibrous membrane of Egg-shell	709
317. White Fibrous Tissue	709
318. Yellow Fibrous Tissue	710
319. Pigment-cells of Choroid, after Heule	712
320. Pigment-cells of <i>Tadpole</i> , after Schwann	713
321. Ciliated Epithelium, after Mandl	714
322. Areolar and Adipose Tissue, after Mandl	715
323. Cartilage of ear of <i>Mouse</i>	716
324. Cartilage of <i>Tadpole</i> , after Schwann	717
325. Striated Muscular Fibre	720
326. Ultimate fibrille of Ditto	721
327. Capillary Circulation in Web of <i>Frog's</i> foot, after Wagner	723
328. Intestinal villi of <i>Monkey</i>	733
329. Various forms of Capillary network, after Berres	732
330. Portion of Gill of <i>Fel</i>	735
331. Interior of Lung of <i>Frog</i>	734
332. Section of Lung of <i>Fowl</i>	734
333. Section of <i>Human Lung</i>	75
334. Microscopic organisms in Levant Mud, after Williamson	744
335. Ditto in Chalk from Gravesend, after Ehrenberg	74
336. Ditto Ditto from Meudon, Ditto	7
337. Vertical section of <i>Nammulite</i>	750
338. Portion of Ditto, more highly magnified	7.
339. Horizontal section of Ditto	75.
340. Section of <i>Orthisoides Pruthi</i> parallel to its surface	753
341. Portions of Ditto, more highly magnified	754
342. Vertical section of Ditto	754
343. Eye of <i>Trilobite</i> , after Buckland	757
344. Section of Tooth of <i>Labyrinthodon</i> , after Owen	758
345. Crystallized Silver	762

INTRODUCTION



No one who attentively examines the progress of any department of Science, save such as are (like Mathematics or Metaphysics) of a purely abstract character, can fail to perceive how much it is dependent upon the perfection of its *instruments*. There are few instances, in fact, in which the invention of a new instrument, or the improvement of an old one, has not given a fresh stimulus to investigation; even where it has done no more than afford that degree of precision to the results of enquiries already in progress, which alone could enable them to be made available as data for philosophical reasoning. But there are many cases in which such inventions or improvements have opened-out entirely new paths of scientific research, leading to fertile fields of investigation whose very existence had been previously unknown, to rich mines of discovery whose treasures had lain uncared-for because entirely unsuspected.—A few examples of this general truth may not be inappropriate, by way of preface to the brief notice which it is intended to give in the present Introduction, of the most important epochs in the history, as well of the Microscope itself, as of its application to the purposes of scientific research.

Thus in taking a retrospective survey of the history of *Astronomy*, we find that every great advance in our knowledge of the Celestial Universe, has been preceded by improvements, either in those instruments for *measuring space and time*, by which the places of the Heavenly bodies are determined, the rate of their movements estimated, and a basis for the computation of their distances ascertained; or, again, in the *telescope*, by which our power of sight is so wonderfully augmented, that we are enabled, when gazing through it into the unfathomable depths of space, to take cognizance of world beyond world and system beyond system, whose remoteness cannot

be expressed by any form of words that shall convey a distinct idea to the mind, and to bring the members of our own group within such *visual* proximity to ourselves, that we can scrutinize their appearance nearly as well as if they had *actually* been brought a thousand times nearer to us. For it was the increased precision of celestial observations on the places and movements of the Planets, which furnished the data whereon Kepler was enabled to base his statement of the laws of their motion. It was the application of the pendulum to the measurement of short intervals of time, that enabled Galileo to ascertain the law of Falling Bodies. And it was not until the precise measurement of a degree upon the surface of the Earth had furnished the means of determining both its own diameter and its distance from the Moon, that Newton was enabled to verify and establish his grand conception, of the identity of that force which deflects the planets from a rectilineal course into elliptical orbits, with that which draws a stone to the ground; and thus to establish that Law of Universal Gravitation, which still remains the most comprehensive, as well as the most simple, of all the generalizations, within which the intellect of man has been able to comprehend the phenomena of Nature. So, again, it was only when the elder Herschel had developed new powers in the telescope, that Sidereal Astronomy could be pursued with any view much higher than that of mapping the distribution of the stars in the celestial sphere; and the present state of our knowledge of double, triple, and other combinations of stars, with their mutually-adjusted movements, of the multifiform clusters of luminous points which seem like repetitions of our own firmament in remote depths of space, and of those nebulous films which may be conceived to be new worlds and systems in process of formation, has only been rendered attainable by the improvements which have been subsequently made in the construction of that majestic instrument.

If we glance at the mode in which the fabric of our existing *Chemistry* has been upreared, we at once see that it could not have attained its present elevation and stability, but for the instrumentality of the perfected *balance*; by whose unerring indications it was, that the first decisive blow was given to the old 'phlogistic' theory, that the foundation was laid for true ideas of chemical combination, that the Laws of that Combination were determined, and that the Combining Equivalents of different elementary substances were ascertained; and by whose means alone can any of those analytical researches

be prosecuted, which are not only daily adding to our knowledge of the composition of the bodies which surround us, and suggesting the most important applications of that knowledge to almost every department of the Arts of Life, but which are preparing a broad and secure foundation for a loftier and more comprehensive system of Chemical Philosophy.

So, again, the *balance of torsion*, the ingenious invention of Cavendish and Coulomb, enables the Physical philosopher not merely to render sensible, but to subject to precise measurement and subdivision, degrees of force that are far too feeble to affect the nicest balance of the ordinary construction, even if it were possible to bring them to act upon it; and strange as it may seem, it has been in such a balance that the Earth itself has been weighed, and that a basis has been thus afforded for the computation of the weights of the different Planets and even of the Sun; whilst in the opposite direction it is employed to furnish those data in regard to the intensity of the electric and magnetic forces, on which alone can any valid theory of their operation be constructed.

The *galvanometer*, again, in which the minutest Electric disturbances are rendered sensible by the deflection of the magnetic needle, has not only brought to light a vast class of most interesting electric changes which were previously unsuspected (one of the most remarkable of these being the existence of electric currents in the nerves of living animals, first ascertained by M. du Bois-Reymond), but has enabled those changes to be estimated with a marvellous amount of exactness; thus furnishing to observations made by its means, a precision which is quite unattainable in any other mode, and which is absolutely essential to the establishment of any valid theory of electric action. And this same instrument is scarcely less valuable, as serving, by a particular modification of it, for the detection and estimation of changes of Temperature far too minute to be measured by the ordinary thermometer; thus affording the requisite means of exactness to observation, in a department of science to which at first sight it appeared to have no relation.

“What an important influence,” says Sir John Herschel, “may be exercised over the progress of a single branch of science, by the invention of a ready and convenient mode of executing a definite measurement, and the construction and common introduction of an instrument adapted for it, cannot be better exemplified than by the instance of the *reflecting goniometer*; this simple, cheap, and portable little instrument

has changed the whole face of Mineralogy, and given it all the characters of one of the exact sciences."

Of all the instruments which have been yet applied to scientific research, there is perhaps not one which has undergone such important improvements within so brief a space of time, as the *Microscope* has received during the second quarter of the present century; and there is certainly none whose use under its improved form has been more largely or more rapidly productive of most valuable results. As an optical instrument, the Microscope is now at least as perfect as the Telescope; for the 6-feet parabolic speculum of Lord Rosse's gigantic instrument, is not more completely adapted to the Astronomical survey of the heavenly bodies, than the achromatic combination of lenses so minute that they can scarcely be themselves discerned by the unaided eye, is to the scrutiny of the Physiologist into the mysteries of life and organization. Nor are the revelations of the one less surprising to those who find their greatest charm in novelty, or less interesting to those who apply themselves to the study of their scientific bearings, than are those of the other. The universe which the Microscope brings under our ken, seems as unbounded in its limit as that whose remotest depths the Telescope still vainly attempts to fathom. Wonders as great are disclosed in a speck of whose minuteness the mind can scarcely form any distinct conception, as in the most mysterious of those nebulae whose incalculable distance baffles our hopes of attaining a more intimate knowledge of their constitution. And the general doctrines to which the labours of Microscopists are manifestly tending, in regard to the laws of Organization and the nature of Vital Action, seem fully deserving to take rank in comprehensiveness and importance with the highest principles yet attained in Physical or Chemical Science.

As the primary object of this treatise is to promote the use of the Microscope, by explaining its construction, by instructing the learner in the best methods of employing it, and by pointing-out the principal directions in which these may be turned to good account, any detailed review of its *history* would be misplaced. It will suffice to state, that whilst the *simple* microscope or magnifying-glass was known at a very remote period, the *compound* microscope,—the powers of which, like those of the telescope, depend upon the combination of two or more lenses,—was not invented until about the end of the sixteenth century; the earlier microscopes having

been little else than modified telescopes, and the essential distinction between the two not having been at first appreciated. Still, even in the very imperfect form which the instrument originally possessed, the attention of scientific men was early attracted to the Microscope; for it opened to them a field of research altogether new, and promised to add largely to their information concerning the structure of every kind of organized body. The Transactions of the Royal Society contain the most striking evidence of the interest taken in microscopic investigations two centuries ago. Their early volumes, as Mr. Quekett truly remarks, 'literally teem' with improvements in the construction of the Microscope, and with discoveries made by its means. The *Micrographia* of Robert Hooke, published in 1667, was, for its time, a most wonderful production; but this was soon surpassed by the researches of Leeuwenhoek, whose name first appears in the Philosophical Transactions, in the year 1673. That with such imperfect instruments at his command, this accurate and pains-taking observer should have seen *so much* and *so well*, as to make it dangerous for any one even now to announce a discovery, without having first consulted his works, in order to see whether some anticipation of it may not be found there, must ever remain a marvel to the microscopist. This is partly to be explained by the fact, that he trusted less to the compound microscope, than to single lenses of high power, the use of which is attended with difficulty, but which are comparatively free from the errors inseparable from the first-named instrument in its original form. The names of Grew and Malpighi, also, appear as frequent contributors to the early volumes of the Philosophical Transactions; the researches of the former having been chiefly directed to the minute structure of Plants, and those of the latter to that of Animals. Both were attended with great success. The former laid the foundation of our anatomical knowledge of the Vegetable tissues, and described their disposition in the roots and stems of a great variety of plants and trees; besides making out many important facts in regard to their physiological actions. The latter did the same for the Animal body; and seems to have been the first to witness the marvellous spectacle of the movement of Blood in the capillary vessels of the Frog's foot,—thus verifying by ocular demonstration that doctrine of the passage of blood from the smallest arteries to the smallest veins, which had been propounded as a rational probability by the sagacious Harvey.

Glimpses of the invisible world of Animalcular life were occasionally revealed to the earlier Microscopists, by which their curiosity must have been strongly excited; yet they do not appear to have entered on this class of investigations, with any large portion of that persevering zeal which they devoted to the analysis of the higher forms of organic structure. Its wonders, however, were gradually unfolded; so that in the various treatises on the Microscope published during the eighteenth century, an account of the plants and animals (but especially of the latter) too minute to be seen by the unaided eye, occupies a conspicuous place. It was towards the middle of that period, that M. Trembley of Geneva first gave to the world his researches on the "Fresh-water Polype" or *Hydra*; the publication of which may be considered to have marked a most important epoch in the history of microscopic enquiry. For it presented to the Naturalist the first known example of a class of animals (of which the more delicate and flexible *Zoophytes* are, so to speak, the skeletons) whose claim to that designation had been previously doubted or even denied,—the terms 'sea-mosses,' 'sea-ferns,' &c., having been applied to them, not merely as appropriately indicating their form and aspect, but as expressive of what even the most eminent Zoologists, as well as Botanists, considered to be their vegetable nature. And it presented to the Physiologist an entirely new type of *animal life*; the wonderful nature of which was fitted not only to excite the liveliest interest, but also to effect a vast extension in the range of the ideas entertained up to that time regarding its nature and capacities. For what animal previously-known could propagate itself by buds like a plant,—could produce afresh any part that might be cut-away,—could form any number of new heads by the completion of the halves into which the previous heads had been slit (thus realizing the ancient fable of the *Hydra*),—could even regenerate the whole from a minute portion, so that when the body of one individual was positively minced into fragments, each of these should grow into a new and complete polype,—could endure being turned inside-out, so that what was previously the external surface should become the lining of the stomach, and *vice versa*,—and could sustain various other kinds of treatment not less strange (such as the grafting of two individuals together, head to head, or tail to tail, or the head of one to the tail of another), not only without any apparent injury, but with every indication, in the vigour of its life, of being entirely free from suffering or damage? (See Chap. XI.)—It was by our own countryman,

Ellis, that the discoveries of Trembley were first applied to the elucidation of the real animal nature of the so-called Coralines;* the structure of which was so carefully investigated by him, that subsequent observers added little to our knowledge of it, until a comparatively recent period.

The true *Animalcules* were first systematically studied, in the latter part of the last century, by Gleichen, a German microscopist, who devised the ingenious plan of feeding them with particles of colouring matter, so as to make apparent the form and position of their digestive cavities; and this study was afterwards zealously pursued by the eminent Danish naturalist, Otho Fred. Muller, to the results of whose labours in this field but little was added by others, until Professor Ehrenberg entered upon the investigation with the advantage of greatly-improved instruments. It was at about the same period with Muller, that Vaucher, a Genevese botanist, systematically applied the Microscope to the investigation of the lower forms of Vegetable life; and made many curious discoveries in regard both to their structure and to the history of their lives. He was the first to notice the extraordinary phenomenon of the spontaneous movement of the *Zoospores* of the humbler aquatic plants, which is now known to be the means provided by Nature for the dispersion of the race (Chaps. VI. VII.); but being possessed with the idea (common to all Naturalists of that period, and still very generally prevalent) that *spontaneous motion* evinces *Animal life*, he interpreted the facts which he observed, as indicating the existence of a class of beings which are Plants at one phase of their lives, and Animals at another,—a doctrine which has since been completely set aside by the advance of physiological knowledge. Notwithstanding this and other errors of *interpretation*, however, the work of Vaucher on the “Fresh-water Confervæ” contains such a vast body of accurate *observation* on the growth and reproduction of the Microscopic Plants to the study of which he devoted himself, that it is quite worthy to take rank with that of Trembley, as having laid the foundation for all our scientific knowledge of these very interesting forms. Although the curious phenomenon of ‘conjugation’ had been previously observed by Muller, yet its connection with the function of Reproduction had not been even suspected by him; and it was by Vaucher that its real import was first discerned, and that its occurrence (which had been regarded

* The structures to which this term is now *scientifically* restricted, are really vegetable.

by Müller as an isolated phenomenon, peculiar to a single species) was found to be common to a large number of humble aquatic forms of vegetation. But little advance was made upon the discoveries of Vaucher in regard to these, save by addition to the number of their specific forms, until a fresh stimulus had been given to such investigations by the improvement of the instrument itself. At present, they are among the most favourite objects of study among a large number of observers, both in this country and on the Continent; and are well deserving of the attention which they receive.

Less real progress seems to have been made in Microscopic enquiry, during the first quarter of the present century, than during any similar period since the invention of the instrument. The defects inseparable from its original construction, formed a bar to all discovery beyond certain limits; and although we are now continually meeting with new wonders, which patient and sagacious observation would have detected at any time, and with any of the instruments then in use, yet it is not surprising that the impression should have become general, that almost everything which it *could* accomplish *had* already been done. The instrument fell under a temporary cloud from another cause; for having been applied by Anatomists and Physiologists to the determination of the elementary structure of the animal body, their results were found to be so discordant, as to give rise to a general suspicion of a want of trustworthiness in the Microscope, and in everything announced upon its authority. Thus both the instrument and its advocates were brought into more or less discredit; and as they continue to lie under this, in the estimation of many, to the present day, it will be desirable to pause here for a while, to enquire into the sources of that discrepancy, to consider whether it is avoidable, and to enquire how far it should lead to a distrust of Microscopic observations, carefully and sagaciously made, and accurately recorded.

It is a tendency common to *all* observers, and not by any means peculiar to Microscopists, to describe what they *believe* and *infer*, rather than what they actually *witness*. The older Microscopic observers were especially liable to fall into this error; since the want of definiteness in the images presented to their eyes, left a great deal to be completed by the imagination. And when, as frequently happened, Physiologists began with *theorizing* on the elementary structure of the body, and allowed themselves to twist their imperfect observations

into accordance with their theories, it was not surprising that their accounts of what they professed to have seen should be extremely discordant. But from the moment that the visual image presented by a well-constructed Microscope, gave almost as perfect an idea of the object, as we could have obtained from the sight of the object itself, if enlarged to the same size and viewed with the unassisted eye, Microscopic observations admitted of nearly the same certainty as observations of any other class; it being only in a comparatively small number of cases, that a doubt can fairly remain about any question of *fact*, as to which the Microscope can be expected to inform us.*

Another fallacy, common like the last to all observations, but with which the Microscopic observations of former times were perhaps especially chargeable, arises from a want of due attention to the *conditions* under which the observations are made. Thus one observer described the Human Blood-corpuscles as flattened disks resembling pieces of money, another as slightly concave on each surface, a third as slightly convex, a fourth as highly convex, and a fifth as globular; and the former prevalence of the last opinion, is marked by the habit which still lingers in popular phraseology, of designating these bodies as 'blood-globules.' Yet all microscopists are now agreed, that their real form, when examined in freshly-drawn blood, is that of circular disks, with slightly-concave surfaces; and the diversity in previous statements was simply due to the alteration effected in the shape of these disks, by the action of water or other liquids added for the sake of dilution; the effect of this being to render their surfaces first flat, then slightly convex, then more highly convex, at last changing their form to that of perfect spheres.—But microscopical enquiries are not in themselves more liable to fallacies of this description, than are any other kinds of scientific investigation; and it will always be found here, as well as elsewhere, that—good instruments and competent observers being pre-supposed—the accordance in *results* will be precisely proportional to the accordance of *conditions*, that is, to the similarity of the objects,

* One of the most remarkable of the *questiones vexatæ* at present agitated, is the nature of the markings on the siliceous valves of *Diatomaceæ* (Chap. vi.); some observers affirming those spots of the surface to be *elevations*, which others consider to be *depressions*. The difference is here one of *interpretation*, rather than of direct *observation*; the nature of the case preventing that kind of view of the object, which could leave no doubt as to the fact; and the conclusion formed being one of inference from a variety of appearances, which will differently impress the minds of different individuals.

the similarity of the treatment to which they may be subjected, and the similarity of the mode in which they may be viewed.*

The more completely, therefore, the statements of Microscopic observers are kept free from those fallacies, to which observations of *any* kind are liable, wherein due care has not been taken to guard against them, the more completely will it be found that an essential agreement exists among them all, in regard to the *facts* which they record. And although the influence of *preconceived theories* still too greatly modifies, in the minds of some, the descriptions they profess to give of the facts actually presented to their visual sense, yet on the whole it is remarkable to what a unity of doctrine the best Microscopists of all countries are converging, in regard to all such subjects of this kind of enquiry, as have been studied by them with adequate care and under similar conditions. Hence it is neither fair to charge upon the Microscopists of the present day the errors of their predecessors; nor is it just to lay to the account of the instrument, what entirely proceeds from the fault of the observer, in recording, not what he sees in it, but what he fancies he can see.

It was at the commencement of the second quarter of the present century, that the principle of *Achromatic correction*, which had long before been applied to the Telescope, was first brought into efficient operation in the construction of the Microscope; for although its theoretical possibility was well known, insuperable difficulties were believed to exist in its practical application. The nature of this most important improvement will be explained in its proper place (Chap. I.); and at present it will be sufficient to say, that within eight or ten years from the date of its first introduction, the character of the Microscope had been in effect so completely transformed, that it became an altogether new instrument; and from being considered but little better than a scientific toy, it soon acquired the deserved reputation of being one of the most perfect instruments ever devised by Art for the investigation of Nature. To this reputation it has a still greater claim at the present time; and though it would be hazardous to deny the possibility of any further improvement, yet the statements of theorists as to what *may* be accomplished,

* In objects of the most difficult class, such as the *Diatomacea*, this last point is one of fundamental importance; very different appearances being presented by the *same object*, according to the mode in which it is illuminated, and the focal adjustment of the object-glass under which it is examined.—See Chap. VI.

arc so nearly equalled by what *has* been effected, that little room for improvement can be considered to remain, unless an entirely new theory shall be devised, which shall create a new set of possibilities

Neither Botanists or Zoologists, Anatomists or Physiologists, were slow to avail themselves of the means of perfecting and extending their knowledge, thus unexpectedly put into their hands; and the records of Scientific Societies, and the pages of Scientific Journals, have ever since teemed, like the early Transactions of the Royal Society, with discoveries made by its instrumentality. All really philosophic enquirers soon came to feel, how vastly the use of the improved Microscope must add to their insight into every department of Organic Nature; and numbers forthwith applied themselves diligently to the labour of investigation. Old lines of research, which had been abandoned as unlikely to lead to any satisfactory issue, were taken up again with the confident expectation of success, which the result has shown to have been well-grounded; and new paths were soon struck-out, each of which, leading into some region previously unexplored, soon cleared the way to others which became alike productive; thus laying open an almost unlimited range of enquiry, which the time that has since elapsed has served rather to extend than to contract, and which the labour that has been devoted to it has rather amplified than exhausted.—A slight sketch of what has already been accomplished by the assistance of the Microscope, in the investigation of the phenomena of Life, seems an appropriate Introduction to the more detailed account of the instrument and its uses, which the present Treatise is designed to embrace.

The comparative simplicity of the structure of Plants, and the relatively-large scale of their elementary parts, had allowed the Vegetable Anatomist, as we have seen, to elucidate some of its most important features, without any better assistance than the earlier Microscopes were capable of supplying. And many of those humbler forms of Cryptogamic vegetation, which only manifest themselves to the unaided eye when by their multiplication they aggregate into large masses, had been made the objects of careful study, which had yielded some most important results. Hence there seemed comparatively little to be done by the Microscopist in Botanical research; and it was not immediately perceived what was the direction in which his labours were likely to be most productive. Many valuable memoirs had been published, from time

to time, on various points of vegetable structure; the increased precision and greater completeness of which, bore testimony to the importance of the aid which had been afforded by the greater efficiency of the instrument employed in such researches. But it was when the attention of Vegetable Physiologists first began to be prominently directed to the history of *development*, as the most important of all the subjects which presented themselves for investigation, that the greatest impulse was given to Scientific Botany; and its subsequent progress has been largely influenced by that impulse, both in the accelerated rate at which it has advanced, and in the direction which it has taken. Although Robert Brown had previously observed and recorded certain phenomena of great importance, yet it is in the Memoir of Prof. Schleiden, first published in 1837, that this new movement may be considered to have had its real origin; so that, whatever may be the errors with which his statements (whether on that occasion, or subsequently) are chargeable, there cannot be any reasonable question as to the essential service he has rendered to science, in pointing out the way to others, on whose results greater reliance may be placed. It was by Schleiden that the fundamental truth first broadly enunciated, that as there are many among the lowest orders of Plants, in which a single cell constitutes the entire individual, each living *for* and *by* itself alone, so each of the cells, by the aggregation of which any individual among the higher Plants consists, has an independent life of its own, besides the 'incidental' life which it possesses as a part of the organism at large: and that the doctrine was first proclaimed, that the *life-history of the individual cell* is therefore the very first and absolutely indispensable basis, not only for Vegetable Physiology, but (as was even then foreseen by his far-reaching mental vision) for Comparative Physiology in general. The first problem, therefore, which he set himself to investigate, was—*how does the cell itself originate?* It is unfortunate that he should have had recourse for its solution, to some of those cases in which the investigation is attended with peculiar difficulty, instead of making more use of the means and opportunities which the 'single-celled' plants afford; and it is doubtless in great part to this cause, that we are to attribute certain fallacies in his results, of which subsequent researches have furnished the correction.

In no department of Botany, has recent Microscopy been more fertile in curious and important results, than in that

which relates to the humblest forms of *Cryptogamia* that abound not only in our seas, rivers, and lakes, but even more in our marshes, pools, and ditches. For, in the first place, these present us with a number of most beautiful and most varied forms, such as on that account alone are objects of great interest to the Microscopist; this is especially the case with the curious group (ranked among Animalcules by Prof. Ehrenberg), which, from the bipartite form of their cells, has received the designation of *Desmidiæ*. In another group, that of *Diatomaceæ* (also still regarded as Animalcules, not only by Ehrenberg, but by many other Naturalists), not only are the forms of the plants often very remarkable, but their surfaces exhibit markings of extraordinary beauty and symmetry, which are among the best 'test-objects' that can be employed for the higher powers of the instrument (Chap. IV.): moreover, the membrane of each cell being coated externally with a film of silica, which not only takes its form, but receives the impress of its minutest markings, the siliceous skeletons remain unchanged after the death of the plants which formed them, sometimes accumulating to such an amount, as to give rise to deposits of considerable thickness at the bottoms of the lakes or pools which they inhabit; and similar deposits, commonly designated as beds of 'fossil animalcules,' are not unfrequently found at a considerable distance from the surface of the ground, on the site of what must have probably once been a lake or estuary, occasionally extending over such an area, and reaching to such a depth, as to constitute no insignificant part of the crust of the globe.—It is not only in the foregoing particulars, however, that the foregoing and other humble Plants have special attractions for the Microscopist; for the study of their *living actions* brings to view many phenomena, which are not only well calculated to excite the interest of those who find their chief pleasure in the act of observing, but are also of the highest value to the Physiologist, who seeks to determine from the study of them what are the acts wherein Vitality may be said essentially to consist, and what are the fundamental distinctions between Animal and Vegetable life. Thus it is among these plants, that we can best study the history of the multiplication of cells by 'binary subdivision,' which seems to be the most general mode of growth and increase throughout the Vegetable kingdom; and it is in these, again, that the process of sexual generation is presented to us under its simplest aspect, in that curious act of 'conjugation' to which reference has

already been made (p. 7). But further, nearly all these Plants have at some period or other of their lives, a power of spontaneous *movement*; which in many instances so much resembles that of Animalcules, as to *seem* unmistakably to indicate their animal nature, more especially as this movement is usually accomplished by the agency of visible *cilia*: and the determination of the conditions under which it occurs, and of the purposes it is intended to fulfil, is only likely to be accomplished after a far more extensive as well as more minute study of their entire history, than has yet been prosecuted, save in a small number of instances. It is not a little remarkable, that in several of the cases in which the life-history of these plants has been most completely elucidated, they have been found to present a great variety of forms and aspects at different periods of their existence, and also to possess several different methods of reproduction; and hence it can be very little doubted, that numerous forms which are commonly reputed to be distinct and unrelated species, will prove in the end to be nothing else than successive stages of one and the same type. One of the most curious results attained by Microscopic enquiry of late years, has been the successive transfer of one group of reputed Animalcules after another, from the Animal to the Vegetable side of the line of demarcation between the two kingdoms; and although, as to the precise points across which this line should be drawn, there is not yet an unanimous agreement, yet there is now an increasing accordance as to its general situation, which, even a few years since, was energetically canvassed. Those who are acquainted with the well-known *Volvor* (commonly termed the 'globe-animalcule') will be surprised to learn that this, with its allies, constituting the family *Volvorineæ*, is now to be considered as on the *Vegetable* side of the boundary. (On the subjects of this paragraph, see Chap. vi.).

Not only this lowest type of Vegetable existence, but the *Cryptogamic* series as a whole, has undergone of late years a very close scrutiny, which has yielded results of the highest importance; many new and curious forms having been brought to light (some of them in situations in which their existence might have been least anticipated), and some of the most obscure portions of their history having received an unexpectedly-clear elucidation. Thus the discovery was announced by M. Audouin in 1837, that the disease termed *muscardine*, which annually carried-off large numbers of the silkworms bred in the South of France, really consists in the growth of a

fungous vegetation in the interior of their bodies, the further propagation of which may be almost entirely prevented by appropriate means; in the succeeding year, the fact was brought forward by several Microscopists, that *yeast* also is composed of vegetable cells, which grow and multiply during the process of fermentation; and subsequent researches have shown that the bodies of almost all animals, not even excepting Man himself, are occasionally infested by Vegetable as well as by animal Parasites, many of them remarkable for their beauty of configuration, and others for the variety of the forms they assume. The various parasites which attack our cultivated plants, again,—such as the ‘blights’ of corn, the potato-fungus, and the vine-fungus,—have received a large measure of attention from Microscopists, and much valuable information has been collected in regard to them. It is still a question, however, which has to be decided upon other than microscopic evidence, how far the attacks of these fungi are to be considered as the *causes* of the diseases to which they stand related, or whether their presence (as is undoubtedly the case in many parallel instances) is the *effect* of the previously-unhealthy condition of the plants which they infest; the general evidence appears to the Author to incline to the latter view.

Of all the additions which our knowledge of the structure and life-history of the higher types of Cryptogamic vegetation has received, since the achromatic microscope has been brought to bear upon them, there is none so remarkable as that which relates to their Reproductive function. For the existence in that group of anything at all corresponding to the *sexual* generation of Flowering-Plants, was scarcely admitted by any Botanists; and those few who did affirm it were unable to substantiate their views by any satisfactory proof, and were (as the event has shown) quite wrong as to the grounds on which they based them. Various isolated facts, the true meaning of which was quite unrecognized, had been discovered from time to time,—such as the existence of the moving filaments now termed ‘antherozoids,’ in the ‘globules’ of the *Chara* (first demonstrated by Mr. Varley in 1834), and in the ‘antheridia’ of *Mosses* and *Liverworts* (as shown by Unger and Meyen in 1837), and the presence of ‘antheridia’ upon what had been always previously considered the embryo-frond of the *Ferns* (first detected by Nageli in 1844): but of the connection of these with the generative function, no valid evidence could be produced, and the sexual reproduction of the

Cryptogamia was treated by many Botanists of the greatest eminence, as a doctrine not less chimerical, than the doctrine of the sexuality of Flowering-plants had appeared to be to the opponents of Linnæus. It was by the admirable researches of Count Suminski upon the development of the Ferns (1848), that the way was first opened to the right comprehension of the reproductive process in that group; and the doctrine of the fertilizing powers of the 'antherozoids,' once established in a single case, was soon proved to apply equally well to many others. Not a year has since elapsed, without the production of new evidence of the like sexuality in the several groups of the Cryptogamic series; this having been especially furnished by Hofmeister in regard to the higher types, by Thuret and Decaisne as to the marine Algæ, and by Tulasne with respect to Lichens and Fungi; and the doctrine may now be considered as established beyond the reach of cavil from any but those, who, having early committed themselves dogmatically to the negative opinion, have not the candour to allow due weight to the evidence on the affirmative side.— With the study of the Reproduction of these plants, that of the history of their *Development* has naturally been connected; and some of the facts already brought to light, especially by the study of certain forms of Fungous vegetation, demonstrate the extreme importance of this enquiry in settling the foundations of Classification. For whereas the arrangement of Fungi, as of other Plants, has been based upon the characters furnished by their fructification, these characters have been found by Tulasne to be frequently subject to variations so wide, that one and the same *individual* shall present two or more kinds of fructification, such as had been previously considered to be peculiar to distinct *orders*. In this department of study, which has been scarcely at all cultivated by Microscopists of our own country, there is a peculiarly wide field for careful and pains-taking research, and a sure prospect of an ample harvest of discovery. (On the subjects of the two preceding Paragraphs, see Chap. VII.).

Although it has been in Cryptogamic Botany, that the zealous pursuit of Microscopic enquiry has been most conducive to scientific progress, yet the attention of Vegetable Anatomists and Physiologists has been also largely and productively directed to the minute structure and life-history of Flowering Plants. For although some of the general features of that structure had been made-out by the earlier observers, and successive additions had been made to the knowledge of

them, previously to the new era to which reference has so often been made, yet all this knowledge required to be completed and made exact, by a more refined examination of the Elementary Tissues than was before possible; and little was certainly known in regard to those processes of growth, development, and reproduction, in which their activity as living organisms consists. All the researches which have been made upon this point, tend most completely to bear-out the general doctrine so clearly set-forth by Schleiden, as to the independent vitality of each integral part of the fabric; and among the most curious results of the enquiries which have been prosecuted in this direction, may be mentioned the discovery, that the movement of 'rotation' of the *protoplasma* (or the viscid granular fluid at the expense of which the nutritive act seems to take place) within the cells, which was first observed by the Abbé Corti in the *Chara* in 1776, is by no means an unique or exceptional case; for that it may be detected in so large a number of instances, among Phanerogamia no less than among Cryptogamia, as apparently to justify the conclusion that it takes place in Vegetable cells generally, at some period or other of their evolution. In studying the phenomena of Vegetable Nutrition, the Microscope has been most effectually applied, not merely to the determination of changes in the form and arrangement of the elementary parts, but also to the detection of such changes in their composition, as ordinary Chemistry would be quite at fault to discover: each individual cell being (so to speak) a laboratory in itself, within which a transformation of organic compounds is continually taking-place, not only for its own requirements, but for those of the economy at large; and these changes being at once made apparent by the application of chemical reagents to microscopic specimens whilst actually under observation. Hence the Vegetable Physiologist finds, in this Microscopic Chemistry, one of his most valuable means of tracing the succession of the changes in which Nutrition consists, as well as of establishing the chemical nature of particles far too minute to be analysed in the ordinary way; and he derives further assistance in the same kind of investigation, from the application of Polarized Light (§ 63), which immediately enables him to detect the presence of mineral deposits, of starch-granules, and of certain other substances which are peculiarly affected by it. One of the most interesting among the general results of such researches, has been the discovery that the *true* cell-wall of the Plant (the 'primordial utricle' of Mohl)

has the same *albuminous* composition as that of the Animal; the external *cellulose* envelope, which had been previously considered as the distinctive attribute of the Vegetable cell, being in reality but a secretion from its surface.—Of all the applications of the Microscope, however, to the study of the life-history of the Flowering-plant, there is none which has excited so much interest, or given-rise to so much discussion, as the nature of the process by which the *Ovule* is *fecundated* by the penetration of the pollen-tube. This question, in the opinion of the Author, may be considered as now determined; and the conclusion arrived-at is one so strictly in harmony with the general results obtained by the study of the (apparently) very different phenomena presented by the Generative process of the Cryptogamia, that it justifies the Physiologist in advancing a general doctrine as to the nature of the function, which proves to be no less applicable to the Animal kingdom than it is to the Vegetable. (See Chap. VIII.).

Among the objects of interest so abundantly offered by the *Animal Kingdom* to the observation of Microscopists furnished with vastly-improved instruments of research, it was natural that those minuter forms of Animal life which teem in almost every stationary collection of water, should engage their early attention; and among those Naturalists who applied themselves to this study, the foremost rank must undoubtedly be assigned to the celebrated German Microscopist, Prof. Ehrenberg. For although it is now unquestionable that he has committed numerous errors,—many doctrines which at first gained considerable currency on the strength of his high reputation, having now been abandoned by almost every one save their originator,—yet when we look at the vast advances which he unquestionably made in our knowledge of Animal-cular life, the untiring industry which he has displayed in the study of it, the impulse which he has given to the investigations of others, and the broad foundation which he has laid for their enquiries in the magnificent works in which his own observations are recorded, we cannot but feel that his services have been almost invaluable, since, but for him, this department of microscopic enquiry would certainly have been in a position far behind that to which it has now advanced. Yet, great as has been the labour bestowed by him and by his followers in the same line of pursuit, it has become increasingly evident of late years that our knowledge of Infusory Animalcules is still in its infancy; that the great fabric erected by Prof. Ehrenberg rests upon a most insecure

foundation; and that the Anatomy, Physiology, and Systematic arrangement of these beings need to be re-studied completely *ab initio*. For, in the first place, there can be no doubt whatever, that a considerable section of the so-called Animalcules belongs to the Vegetable kingdom; consisting, as already pointed out, of the *motile* forms of the humbler Plants, of which a very large proportion pass, at some period of their existence, through a stage of activity that serves for their diffusion. Moreover, in another group whose character has been entirely misconceived by the great German Microscopist, and was first clearly discriminated by M. Dujardin, there is neither mouth nor stomach of any kind; the minute plants and animals which serve it as food, being incorporated, as it were, with the soft animal jelly, which constitutes the almost homogeneous body; and this jelly further extending itself into 'pseudopodial' prolongations, whereby these alimentary particles are laid hold-of and drawn-in. It was by the same distinguished French Microscopist, that the important fact was first discovered, that animals of this *Rhizopod* type are really the fabricators of those minute shells, which, from their Nautilus-like aspect, had been previously regarded as belonging to the highest class of the Molluscous Sub-Kingdom; and the whole of this most interesting group, which had received from M. D'Orbigny (who first perceived the speciality of its nature, and made a particular study of it) the designation of *Foraminifera*, has thus had its place in the Animal scale most strangely reversed; being at once degraded from a position but little removed from Vertebrated animals, to a level in some respects even lower than that of the ordinary Animalcules.

But even when Prof. Ehrenberg's class of *Polygastrica* has been thus reduced, by the removal of those forms which are true Plants, and by the detachment of such as belong to the Rhizopod group, we find that our knowledge of its real nature is almost wholly *to be gained*; since little else has yet been accomplished than a description of a multitude of *forms*, of whose *history* as living beings scarcely anything else is known, than that they take food into the interior of their bodies by means of an oral orifice, that they digest this food and appropriate it to their own growth, and that they multiply themselves by binary subdivision. Now there is a very strong analogical probability, that many even of the most dissimilar forms of these Animalcules, will prove to be different states of one and the same; for their multiplication by binary subdivision being

not a true generative process, but being merely (so to speak) the growth of the individual, we may be almost certain that sooner or later a new phase will present itself, consisting in the evolution of proper sexual bodies, which will perform a true generative act, the products of which may be very probably quite different from the forms we are accustomed to regard as peculiar to each species. The attention of several eminent Microscopists at the present time is strongly fixed upon this part of the enquiry; which can only be efficiently prosecuted, by *limiting* the range of observation for a time to a *small number* of forms, and pursuing these through all the phases of their existence.

Among the most important of Prof. Ehrenberg's unquestioned discoveries, we are undoubtedly to place that of the comparatively high organization of the *Rotifera*, or Wheel-Animalcules and their allies; for which, though previously confounded with the simpler Infusoria, he asserted and vindicated a claim to a far more elevated rank. For although in this instance, too, some of his descriptions have been shown to be incorrect, and many of his inferences to be erroneous, and although subsequent observers are not agreed among themselves as to many important particulars, yet all assent to the general accuracy of Prof. Ehrenberg's statements, and recognize the title of the *Rotifera* to a place not far removed from that of the Vermiform tribes.—A parallel discovery was made about the same time by MM. Audouin and Milne-Edwards, in regard to the *Flustra* and their allies, which had previously ranked among those flexible Zoophytes popularly known as 'corallines,' and are often scarcely to be distinguished from them in mode of growth or general aspect; * but which were separated as a distinct order by these observers, on account of their possession of a second orifice to the alimentary canal, and the general tendency of their plan of organization to that which characterizes the inferior Mollusca. The importance of this distinction was at once recognized; and the group received the designation of *Polyzoa* from Mr. J. V. Thompson, and of *Bryozoa* from Prof. Ehrenberg. The organization of this very interesting group was further

* "You go down," says Mr. Kingsley, "to any shore after a gale of wind, and pick up a few delicate little sea-ferns. You have two in your hand (*Sertularia operculata* and *Gemellaria lorculata*), which probably look to you, even under a good pocket-magnifier, identical or nearly so. But you are told to your surprise, that however like the dead horny polypidoms which you hold may be, the two species of animal which have formed them, are at least as far apart in the scale of creation as a quadruped is from a fish."

elucidated, some years subsequently, by the admirable observations of Dr. Arthur Farre upon a newly-discovered form (named by him *Bowerbankia*), the transparence of whose envelopes allowed its internal structure to be distinctly made-out; and the additional features which he detected, were all such as to strengthen the idea already entertained of its essentially Molluscan character. This idea received its final and complete confirmation from the admirable researches of M. Milne-Edwards on the *Compound Ascidians*, which are the lowest animals whose Molluscous nature had been previously acknowledged; these having been discovered by him to agree with Zoophytes in their plant-like attribute of extension by 'gemmation' or budding, and to present, in all the most important features of their organization, an extremely close approximation to the Bryozoa.—Thus whilst Microscopic research has degraded the Foraminifera from their supposed rank with the Nautilus and Cuttlefish, to the level of the Sponge, it has raised the Wheel Animalcules into proximity with the aquatic Worms, and the humble 'Sea-Mat,' formerly supposed to be a Plant, to a position not much below that of the Oyster and Mussel*.

Another most curious and most important field of Microscopic enquiry has been opened-up in the study of the *Transformations* which a large proportion of the lower animals undergo, during the early stages of their existence; and notwithstanding that it has even yet been very imperfectly cultivated, the unexpected result has been already attained, that the fact of 'metamorphosis,'—previously known only in the cases of Insects and Tadpoles, and commonly considered as an altogether *exceptional* phenomenon,—is almost *universal* among the inferior tribes; it being a rare occurrence for the offspring to come-forth from the egg in a condition bearing any resemblance to that which characterizes the adult, and the latter being in general attained only after a long series of changes, in the course of which many curious phases are presented. One of the earliest and most remarkable discoveries which was made in this direction,—that of the metamorphosis of the *Cirrhipeds* (Barnacles and their allies) by Mr. J. V. Thompson,—proved of most important assistance in the determination of the true place of that group, which had previously been a matter of controversy; for although in

* With reference to the subjects of the three preceding paragraphs, see Chaps. IX., X., XI.

their outward characters they bear such a resemblance to Mollusks, that the Barnacles which attach themselves to floating timber, and the Acorn-shells which incrust the surfaces of rocks, are unhesitatingly ranked by Shell-collectors among their 'multivalves,' yet the close resemblance which exists between their early forms and the little Water-Fleas which swarm in our pools, makes it quite certain that the Barnacles not only belong to the Articulated instead of to the Molluscous series, but that they must be ranked in close proximity to the Entomostracous division of the Crustacea, if not actually as members of it. To the same discoverer, moreover, we owe the knowledge that even the common *Crab* undergoes metamorphoses scarcely less strange, its earliest form being a little creature of most grotesque shape, which had been previously described as an adult and perfect Entomostracan; so that, although scarcely any two creatures can apparently be more unlike than a Barnacle and a Crab, they have (so to speak) the same starting-point; the difference in their ultimate aspect chiefly arising from the difference in the proportionate development of parts which are common to both.—A still more remarkable series of Metamorphoses has recently been shown by Prof. Müller to exist among the *Echinoderms* (Star-fish, Sea-urchins, &c.); whose development he has studied with great perseverance and sagacity. Thus the larva of the Star-fish is an active free-swimming animal, having a long body with six slender arms on each side, from one end of which the young star-fish is (so to speak) budded-off; and when this has attained a certain stage of development, the long twelve-armed body separates from it and dies-off, its chief function having apparently been, to carry the young Star-fish to a distance from its fellows, and thus to prevent overcrowding by the accumulation of individuals in particular spots, which would be liable to occur if they never had any more active powers of locomotion than they possess in their adult state.—Scarcely less remarkable are the changes which are to be witnessed in the greater number of aquatic *Mollusks*, almost all of which, however inert in their adult condition, possess active powers of locomotion in their larval state; some being propelled by the vibratile movement of cilia disposed upon the head somewhat after the fashion of those of Wheel-animalcules, and others by the lateral strokes of a sort of tail which afterwards disappears like that of a Tadpole.—Among the *Annelids* or marine worms, again, there is found to be an extraordinary dissimilarity, though of a somewhat

different nature, between the larval and the adult forms : for they commonly come-forth from the egg in a condition but little advanced beyond that of *Animalcules* ; and, although they do not undergo any metamorphosis comparable to that of *Insects*, they pass through a long series of phases of development (chiefly consisting in the *successive production* of new joints or segments, and of the organs appertaining to these) before they acquire their complete type.—In nearly all the foregoing cases it may be remarked, that the larval forms of different species bear to one another a far stronger resemblance than exists among adults, the distinguishing characters of the latter being only evolved in the course of their development ; and every new discovery in this direction only gives fresh confirmation to the great law of development early detected by the sagacity of Von Baer, that *the more special forms of structure arise out of the more general, and this by a gradual change*. The meaning of this law will become obvious hereafter, when some of the principal cases to which it applies shall have been brought in illustration of it (Chap. XII.).

A still more curious series of discoveries has been made, by means of the Microscope, in regard to the early development of the Medusan *Acalephs* (jelly-fish, &c.), and the relationship that exists between them and the *Hydraform Zoophytes* ;—two groups of animals, which had been previously ranked in different classes, and had not been supposed to possess anything in common. For it has been clearly made out by the careful observations of Sars, Siebold, Dalycell, and others, that those delicate arborescent *Zoophytes*, each polype of which is essentially a *Hydra*, not only grow by extending themselves into new branches, like plants, sometimes also budding-off detached *gemme*, which multiply their kind by developing themselves into *Zoophytic* forms like those whence they sprang ; but also produce peculiar buds having all the characters of *Medusæ*, which contain the proper generative organs of the *Zoophyte*, but which, usually detaching themselves from the stock that bore them, swim freely through the ocean as minute jelly-fish, without exhibiting the slightest trace of their originally-attached condition. The *Medusæ* in due time produce fertile eggs ; and each egg develops itself, not into the form of its immediate progenitor, but into that of the *Zoophyte* from which the *Medusa* was budded-off. And thus a most extraordinary alternation of forms is presented, between the *Zoophyte*, which may be compared to the *growing* or *vegetating* stage of a *Plant* (its polypes representing the

leaf-buds), and the Medusa, the development of which marks its *flowering* stage.—So again, from the investigation of the early history of those larger forms of ‘jelly-fish’ with which every visitor to the sea-coast is familiar, it has been rendered certain that they too are developed from Polype-larvæ, usually of very minute size, which give-off Medusa-buds; so that whilst *they* are best known to us in their Medusan state, and the Hydraform Zoophytes in their polypoid state, each of these groups is the representative of a certain stage in the life-history of one and the same tribe of these curious beings, which, when complete, includes both states, as will be hereafter shown in more detail (Chap. XI).—Changes very similar in kind, and in many respects even more remarkable, have been found by microscopic enquiry to take place among the *Entozoa* (intestinal worms); but being interesting only to professed Naturalists and scientific Physiologists, they scarcely call for particular notice in a treatise like the present.

It has not been among the least important results of the new turn which Zoological enquiry has thus taken, that a far higher spirit has been introduced into the cultivation of this science, than previously pervaded it. Formerly it was thought, both in Zoology and in Botany, that Classification might be adequately based on external characters alone; and the scientific acquirements of a Naturalist were estimated rather by the extent of his acquaintance with these, than by any knowledge he might possess of their internal organization. The great system of Cuvier, it is true, professed to rest upon organization as its basis; but the acquaintance with this which was considered requisite for the purpose, was very limited in its amount and superficial in its character; and no Naturalist formerly thought of studying the history of Development as a necessary adjunct to the Science of Classification. How essential a knowledge of it has now become, however, if only as a basis for any truly natural arrangement of Animals, must have become apparent from the preceding sketch; and it has thus come to be felt and admitted amongst all truly-philosophic Naturalists, that the complete study of any particular group, even for the purposes of classification, involves the acquirement of a knowledge, not only of its intimate structure, but of its entire life-history. And thus Natural History and Physiology,—two departments of the great Science of Life, which the Creator inextricably blended, but which Man has foolishly striven to separate,—are now again being brought into their original and essential harmony; and

it is coming to be thought more creditable, to give a complete elucidation of the history of even a single species, than to describe any number of new forms, about which nothing else is made-out save what shows itself on the surface.

Thus every Microscopist, however limited may be his opportunities, has a wide range of observation presented to him in the study of the lower forms of Animal life; with the strongest incitement to persevering and well-directed enquiry, that the anticipation of novelty, and the expectation of valuable results, can afford. For, notwithstanding the large number of admirable records which have been already published (chiefly, we must admit with regret, by Continental Naturalists) upon the developmental history of the lower tribes of Animals, there is no one of the subjects that have been just passed in review, of which the knowledge hitherto gained can be regarded as more than a sample of that which remains to be acquired. Records like those already referred-to, might easily be multiplied a hundred-fold, with infinite advantage to Science; if those Microscopists who spend their time in desultory observation, and in looking at some favourite objects over and over again, would but concentrate their attention upon some particular species or group, and work-out its entire history with patience and determination. And the observer himself would find this great advantage in so doing,—that an enquiry thus pursued gradually becomes to him an object of such attractive interest, that he experiences a zest in its pursuit to which the mere *dilettante* is an entire stranger,—besides enjoying all the mental profit, which is the almost necessary result of the *thorough* performance of *any* task that is not in itself unworthy. And what *can* be a more worthy occupation, than the attempt to gain an insight, however limited, into the operations of Creative Wisdom?—these being not less wonderfully displayed among the forms of Animal life which are accounted the simplest and least attractive, than in those which more conspicuously solicit the attention of the Student of Nature, by the beauty of their aspect or the elaborateness of their organization.

It has not been, however, in the study of the minuter forms of Animal life alone, that the Microscope has been turned to valuable account; for the Anatomists and Physiologists who had made the Human fabric the especial object of their study, and who had been led to believe that the knowledge accumulated by their repeated and persevering scrutiny into every portion

accessible to their vision, was all which it lay within their power to attain, have found in this new instrument of research, the means of advancing far nearer towards the *penetralia* of Organization, and of gaining a much deeper insight into the mysteries of Life, than had ever before been conceived possible. For every part of the entire organism has been, so to speak, decomposed into its *elementary tissues*, the structure and actions of each of which have been separately and minutely investigated; and thus a new department of study, which is known as *Histology* (or Science of the Tissues) has not only been marked-out, but has already made great advances towards completeness. In the pursuit of this enquiry, the Microscopists of our day have not limited themselves to the fabric of Man, but have extended their researches through the entire range of the Animal kingdom; and in so doing, have found, as in every other department of Nature, a combination of endless variety in detail, with a marvellous simplicity and uniformity of general plan. Thus the *bones* which constitute the skeleton of the Vertebrated animal,—however different from each other in their external configuration, in the arrangement of their compact and their cancellated portions, and other such particulars as specially adapt them for the purposes they have to perform in each organism,—all consist of a certain kind of tissue, distinguished under the microscope by features of a most peculiar and interesting kind; and these features, whilst presenting (like those of the Human countenance) a certain general conformity to a common plan, exhibit (as Prof. Quekett has shown) such distinctive modifications of that plan in the different classes and orders of the Vertebrated series, that it is generally possible by the microscopic examination of the merest fragment of a bone, to pronounce with great probability as to the *natural family* to which it has belonged. Still more is this the case in regard to the *Teeth*, whose organic structure (originally detected by Lceuwenhoek) has been newly and far more completely elucidated by Profrs. Purkinje, Retzius, Owen, and Tomes; for the enquiry into the comparative structure of these organs, which has been prosecuted by Prof. Owen, in particular, through the entire range of the Vertebrated series, has shown that, with an equally close conformity to a certain *general* plan of structure, there are at the same time still wider diversities in detail, which are so characteristic of their respective groups, that it is often possible to discriminate, not only families, but even genera and species,

by careful attention to the minute features of their structure. Similar enquiries, with results in many respects analogous, have been carried-out by the Author, in regard to the *Shells* of Mollusks, Crustaceans, and Echinoderms; his researches having not only demonstrated the regularly-organized structure of these protective envelopes (which had been previously affirmed to be mere inorganic exudations, presenting in many instances a crystalline texture), but having shown that many natural groups are so distinctively characterized by the microscopic peculiarities they present, that the inspection of a minute fragment of Shell will often serve to determine, no less surely than in the case of bones and teeth, the position of the animal of which it formed part. The soft parts of the Animal body, moreover, such as the *cartilages* which cover the extremities of the bones and the *ligaments* which hold them together at the joints, the *muscles* whose contraction develops motion and the *tendons* which communicate that motion, the *nervous ganglia* which generate nervous force and the *nervous fibres* which convey it, the *skin* which clothes the body and the *mucous* and *serous* membranes which line its cavities, the *assimilating glands* which make the blood and the *secreting glands* which keep it in a state of purity,—these, and many other tissues that might be enumerated, are severally found to present characteristic peculiarities of structure, which are more or less distinctly recognisable throughout the Animal series, and which bear the strongest testimony to the Unity of the Design in which they all originated. As we descend to the lower forms of Animal life, however, we find these distinctions less and less obvious; and we at last come to fabrics of such extreme simplicity and *homogeneousness*, that every part seems to resemble every other in structure and actions; no provision being made for that ‘division of labour’ which marks the higher types of organization, and which, being the consequence of the development of separate *organs* each having its special work to do, can only be effected where there is a ‘differentiation’ of parts, that gives to the entire fabric a character of *heterogeneousness*.

The Microscopic investigation whose nature has thus been sketched, has not only been most fruitful in the discovery of individual facts, but has led to certain general results, of great value in Physiological Science. Among the most important of these, is the complete metamorphosis which has been effected in the ideas previously entertained regarding *living action*; such having been essentially based on the

Circulation of the blood, as the only vital phenomenon of which any direct cognizance could be gained through the medium of the senses. For it gradually came to be clearly perceived, that in the Animal as in the Plant, *each integral portion of the Organism possesses an independent Life of its own*, in virtue of which it performs a series of actions peculiar to itself, provided that the conditions requisite for those actions be supplied to it, and that the Life of the body as a whole (like a symphony performed by a full orchestra) consists in the harmonious combination of its separate instrumental acts, —the circulation of the blood, instead of *making the tissues*, simply affording the supply of prepared nutriment, at the expense of which they *evolve themselves* from germs previously existing. This general doctrine was first put prominently forwards by Schwann, whose “Microscopical Researches into the Accordance in the Structure and Growth of Animals and Plants,” published in 1839, marks the commencement of a new era in all that department of Animal Physiology, which comprises the simply-vegetative life of the organized fabric. These researches, avowedly based upon the ideas advanced by Schleiden, were prosecuted in the same direction as his had been; the object which this admirable observer and philosophic reasoner specially proposed to himself, being the study of the *development* of the Animal tissues. He found that although their evolution cannot be watched while in actual progress, its history may be traced-out by the comparison of the successive stages brought to light by Microscopic research; and in so far as this has been accomplished for each separate part of the organism, the structure and actions of its several components, however diverse in their fully-developed condition, are found to resemble each other more and more closely, the more nearly these parts are traced-back to their earliest appearance. Thus we arrive in our retrospective survey, at a period in the early history of Man, at which the whole embryonic mass is but *a congeries of cells*, all apparently similar and equal to each other; and going still further back, it is found that all these have had their origin in the subdivision of *a single primordial cell*, which is the first defined product of the generative act. On this single cell, the Physiologist bases his idea of the most elementary type of Organization; whilst its actions present him with all that is essential to the notion of Life. And in pursuing the history of the germ, from this, its simplest and most *homogeneous* form, to the assumption of that completed and perfected type

which is marked by the extreme *heterogeneousness* of its different parts, he has another illustration of that law of *progress from the general to the special*, which is one of the highest principles yet attained in the science of Vitality.

But further, the Physiologist, not confining his enquiries to Man, pursues the like rescarches into the developmental history of other living beings, and is soon led to the conclusion that the same is true of them also; each Animal, as well as each Plant, having the same starting-point in the single cell; and the distinctive features by which its perfected form is characterized, how striking and important soever these may be, arising in the course of its development towards the condition it is ultimately to present. In the progress of that evolution, those fundamental differences which mark-out the great natural divisions of the Animal and the Vegetable Kingdoms respectively, are the first to manifest themselves; and the subordinate peculiarities which distinguish classes, orders, families, genera, and species, successively make their appearance, usually (but not by any means constantly) in the order of importance which Systematists have assigned to them. And it is in thus pursuing, by the aid which the Microscope alone can afford to his visual power, the history of the Organic Germ, from that simple and homogeneous form which seems common to every kind of living being, either to that complex and most heterogeneous organism which is the mortal tenement of Man's immortal spirit, or only to that humble Protophyte or Protozoon, which lives and grows and multiplies without showing any essential advance upon its embryonic type,—that the Physiologist is led to his grandest conception of the Unity and All-Comprehensive nature of that Creative Design, of which the development of every individual Organism, from the lowest to the highest, is a separate exemplification, at once perfect in itself, and harmonious with every other.

It has been the purpose of the foregoing sketch, to convey an idea, not merely of the services which the Microscope has already rendered to the *collector of facts* in every department of the Science of Life, but also of the value of these facts as a foundation for *philosophical reasoning*. For it is when thus utilized, that observations, whether made with the Microscope or with the Telescope, or by any other instrumentality, acquire their highest value, and excite the strongest interest in the mind. But as it is not every one who is prepared by his previous acquirements to appreciate such rescarches, according to

the scientific estimate of their importance, it may be well now to address ourselves to that large and increasing number, who are disposed to apply themselves to Microscopic research as *amateurs*, following the pursuit rather as a means of wholesome recreation to their own minds, than with a view to the extension of the boundaries of existing knowledge; and to those in particular who are charged, whether as parents or as instructors, with the direction and training of the youthful mind.

All the advantages which have been urged at various times, with so much sense and vigour,* in favour of the study of Natural History, apply with full force to Microscopical enquiry. What better encouragement and direction can possibly be given to the exercise of the *observing* powers of a child, than to habituate him to the employment of this instrument upon the objects which immediately surround him, and then to teach him to search-out novelties among those less immediately accessible? The more we limit the natural exercise of these powers, by the use of those methods of education which are generally considered to be specially advantageous for the development of the Intellect,—the more we take him from fields and woods, from hills and moors, from river-side and sea-shore, and shut him up in close school-rooms and narrow play-grounds, limiting his attention to abstractions, and cutting him off even in his hours of sport from those sights and sounds of Nature which seem to be the appointed food of the youthful spirit,—the more does it seem important that he should in some way be brought into contact with her, that he should have his thoughts sometimes turned from the pages of books to those of Creation, from the teachings of Man to those of God. Now if we attempt to give this direction to the thoughts and feelings in a merely *didactic* mode, it loses that spontaneousness which is one of its most valuable features. But if we place before the young a set of objects which can scarcely fail to excite their healthful curiosity, satisfying this only so far as to leave them still enquirers, and stimulating their interest from time to time by the disclosure of such new wonders as arouse new feelings of delight, they come to look upon the pursuit as an ever-fresh fountain of happiness and enjoyment, and to seek every opportunity of following it for themselves.

There are no circumstances or conditions of life, which need be altogether cut-off from these sources of interest and

* By none more forcibly than by Mr. Kingsley, in his recent little volume entitled "*Glaucus, or the Wonders of the Shore.*"

improvement. Those who are brought-up amidst the wholesome influences of a country life, have, it is true, the greatest direct opportunities of thus drawing from the Natural Creation the appropriate nurture for their own spiritual life. But the very familiarity of the objects around them, prevents these from exerting their most wholesome influence, unless they be led to see how much there is *beneath the surface* even of what they seem to know best; and in rightly training them to look for this, how many educational objects,—physical, intellectual, and moral,—may be answered at the same time! “A walk without an object,” says Mr. Kingsley, “unless in the most lovely and novel scenery, is a poor exercise; and as a recreation utterly nil. If we wish rural walks to do our children any good, we must give them a love for rural sights, an object in every walk; we must teach them—and we can teach them—to find wonder in every insect, sublimity in every hedge-row, the records of past worlds in every pebble, and boundless fertility upon the barren shore; and so, by teaching them to make full use of that limited sphere in which they now are, make them faithful in a few things, that they may be fit hereafter to be rulers over much.” What can be a more effectual means of turning such opportunities to the best account, than the employment of an aid which not only multiplies almost infinitely the sources of interest presented by the objects with which our eyes are most familiar, but finds inexhaustible life where all seems lifeless, ceaseless activity where all seems motionless, perpetual change where all seems inert?—Turn, on the other hand, to the young who are growing-up in our great towns, in the heart of the vast Metropolis, whose range of vision is limited on every side by bricks and mortar, who rarely see a green leaf or a fresh blade of grass, and whose knowledge of animal life is practically limited to the dozen or two of creatures that everywhere attach themselves to the companionship of Man, and shape their habits by his. To attempt to inspire a real love of Nature by books and pictures, in those who have never felt her influences, is almost hopeless. A child may be interested by accounts of her wonders, as by any other instructive narrative; but they have little of *life* or *reality* in his mind,—far less than has the story of adventure which appeals to his own sympathies, or even than the fairy tale which charms and fixes his imagination.—But here the Microscope may be introduced with all the more advantage, as being almost the only means accessible under such circumstances, for supplying what is needed. A single rural or even

suburban walk will afford stores of pleasurable occupation for weeks, in the examination of its collected treasures. A large glass jar may be easily made to teem with life, in almost as many and as varied forms as could be found by the unaided eye in long and toilsome voyages over the wide ocean; and a never-ending source of amusement is afforded by the observation of their growth, their changes, their movements, their habits. The school-boy thus trained, looks forward to the holiday which shall enable him to search afresh in some favourite pool, or to explore the wonders of some stagnant basin, with as much zest as the keenest sportsman longs for a day's shooting on the moors, or a day's fishing in the best trout stream; and with this great advantage over him,—that his excursion is only the beginning of a fresh stock of enjoyment, instead of being in itself the whole.

This is no imaginary picture, but one which we have constantly under our eyes; and no argument can be needed to show the value of such a taste, to such, at least, as have set clearly before their minds the objects at which they should aim in the great work of Education. For we have not merely to train the intellectual powers and to develop the moral sense; but to form those tastes—those 'likes and dislikes'—which exercise a more abiding and a more cogent influence on the conduct, than either the reason or the mere knowledge of duty. It is our object to foster all the higher aspirations, to keep in check all that is low and degrading. But the mind *must* have recreation and amusement; and the more closely it is kept by the system of education adopted, to the exercise of any one set of powers, the more potent will be that reaction which will urge it, when restraint is removed, to activity of some other kind; and the more important is it, that this reaction should receive a direction to what is healthful and elevating, instead of to what is weakening and degrading. It is quite a mistake to imagine that those evil habits which result from a wrong exercise of the natural powers, a wrong direction of the natural tendencies, can be effectually antagonized by the simple effort at *repression*. The constant exercise either of external coercion or of internal restraint, tends to keep the attention directed towards the forbidden object of gratification, the malady is only held in check, not cured; and it will break out, perhaps with augmented force, whenever the perpetually-present impulses shall derive more than ordinary strength from some casual occurrence, or the restraining power shall have been temporarily weakened. The only

effectual mode of keeping in check the *wrong*, is by making use of these same powers and tendencies in a *right* mode; by finding out objects whereon they may be beneficially exercised; and by giving them such a direction and encouragement, as may lead them to *expend themselves* upon these, instead of fretting and chafing under restraint, ready to break loose at the first opportunity. There is no object on which the youthful energy can be employed more worthily, than in the pursuit of Knowledge; no kind of knowledge can be made more attractive, than that which is presented by the Works of Creation; no source is more accessible, no fountain more inexhaustible; and there is none which affords, both in the mode of pursuing it, and in its own nature, so complete and beneficial a diversion from the ordinary scholastic pursuits.

If there be one class more than another, which especially needs to have its attention thus awakened to such objects of interest, as, by drawing its better nature into exercise, shall keep it free from the grovelling sensuality in which it too frequently loses itself, it is our Labouring population; the elevation of which is one of the great social problems of the day. On those who are actively concerned in promoting and conducting its education, the claims and advantages of the Study of Nature can scarcely be too strongly urged; since experience has fully proved,—what might have been *a priori* anticipated,—that where the taste for this pursuit has been *early* fostered by judicious training, it becomes so completely a part of the mind, that it rarely leaves the individual, however unfavourable his circumstances may be to its exercise, but continues to exert a refining and elevating influence through his whole subsequent course of life.—Now for the reasons already stated, the Microscope is not merely a most valuable adjunct in such instruction, but its assistance is essential in giving to almost every Natural object its highest educational value; and whilst the *country* Schoolmaster has the best opportunities of turning it to useful account, it is to the *city* Schoolmaster that, in default of other opportunities, its importance as an educational instrument should be the greatest.—It was from feeling very strongly how much advantage would accrue from the introduction of a form of Microscope, which should be at once *good* enough for Educational purposes, and *cheap* enough to find its way into every well-supported School in town and country, that the Author suggested to the Society of Arts in the summer of 1854, that it should endeavour to carry-out an object so strictly in accordance with the enlightened purposes

which it is aiming to effect; and this suggestion having been considered worthy of adoption, a Committee, chiefly consisting of experienced Microscopists, was appointed to carry it into effect. It was determined to aim at obtaining two instruments;—a *simple* and low-priced microscope for the use of Scholars, to whom it might be appropriately given as a reward for zeal and proficiency in the pursuit of Natural History, not in books, but in the field;—and a *compound* Microscope for the use of Teachers, of capacity sufficient to afford a good view of every kind of object most likely to interest the pupil or to be within the reach of the instructor. Notwithstanding the apprehensions generally expressed, that no instruments at all likely to answer the intended purpose could possibly be produced at the prices specified, the result has proved their fallacy; for among several instruments of greater or less efficiency, sent in competition for the award, the Committee was able to select a Simple and a Compound Microscope fully answering their expectations, and henceforth to be supplied to the public at a cost so low as to place these instruments (it may be hoped) within the reach of almost every one to whom they are likely to be of service. An account of these two Microscopes will be given hereafter. (Chap. II., §§ 29, 31).

It is not alone, however, as furnishing an attractive object of pursuit for the young—fitted at once to excite a wholesome taste for novelty, ever growing with what it feeds on, and to call forth the healthful exercise of all those powers, both physical and mental, which can minister to its gratification,—that Natural-History-studies in general, and Microscopic enquiry in particular, are to be specially commended as a means of intellectual and moral discipline; for there is no capacity, however elevated, to which they do not furnish ample material for the exercise of all its best powers, no period of life which may not draw from them its purest pleasures. Even to *observe well* is not so easy a thing as some persons imagine. Some are too hasty, imagining that they can take in everything at a glance, and hence often forming very erroneous or imperfect notions, which may give an entirely wrong direction not only to their own views but to those of others, and may thus render necessary an amount of labour for the ultimate determination of the truth, many times as great as that which would have sufficed in the first instance, had the original observations been accurately made and faithfully recorded. Others, again, are too slow and hesitating; and fix their attention too much upon details, to be able to

enter into the real significance of what may be presented to the vision. Although ignorance has doubtless much to do in producing both these faults, yet they both have their source in mental tendencies which are not corrected by the mere acquisition of knowledge, and which are very inimical, not merely to its fair reception, but also to the formation of a sound judgment upon any subject whatever. The habit of guarding against them, therefore, once acquired in regard to Microscopic observation, will be of invaluable service in every walk of life. Not less important is it (as has been already shown), to keep our observations free alike from the bias of preconceived ideas, and from the suggestive influence of superficial resemblances; and here, too, we find the training which Microscopical study affords, especially when it is prosecuted under the direction of an experienced guide, of the highest value in forming judicious habits of thought and action. To set the young observer to examine and investigate for himself, to tell him merely *where* to look and (in general terms) *what* to look-for, to require from him a careful account of what he sees, and then to lead him to compare this with the descriptions of similar objects by Microscopists of large experience and unquestionable accuracy, is not only the best training he can receive as a Microscopist, but one of the best means of preparing his mind for the exercise of its powers in any sphere whatever.

It cannot be too strongly or too constantly kept in view, that the value of the results of Microscopic enquiry will depend far more upon the sagacity, perseverance, and accuracy of the Observer, than upon the elaborateness of his instrument. The most perfect Microscope ever made, in the hands of one who knows not how to turn it to account, is valueless; in the hands of a careless, a hasty, or a prejudiced observer, it is worse than valueless, as furnishing new contributions to the already large stock of errors that pass under the guise of scientific truths. On the other hand, the least costly Microscope that has ever been constructed, how limited soever its powers, provided that it gives no *false* appearances, shall furnish to him who knows what *may* be done with it, a means of turning to an account, profitable alike to science and to his own immortal spirit, those hours which might otherwise be passed in languid *ennui*, or in frivolous or degrading amusements,* and even of immortalizing his name by the discovery

* "I have seen," says Mr. Kingsley, "the cultivated man, craving for travel and success in life, pent up in the drudgery of London work, and yet keeping

of secrets in Nature as yet undreamed of. A very large proportion of the great achievements of Microscopic research that have been noticed in the preceding outline, have been made by the instrumentality of microscopes which would be generally condemned in the present day as utterly unfit for any scientific purpose; and it cannot for a moment be supposed, that the field which Nature presents for the prosecution of enquiries with instruments of comparatively limited capacity, has been in any appreciable degree exhausted. On the contrary, what *has been* done by these and scarcely superior instruments, only shows how much there is *to be* done. The Author may be excused for citing, as an apposite example of his meaning, the curious results he has recently obtained from the study of the development of the *Purpura lapillus* (rock-whelk), which will be detailed in their appropriate place (Chap. XII); for these were obtained almost entirely by the aid of *single lenses*, the Compound Microscope having been only occasionally applied to, for the verification of what had been previously worked-out, or for the examination of such minute details as the power employed did not suffice to reveal.

But it should be urged upon such as are anxious to do service to Science, by the publication of discoveries which they suppose themselves to have made with comparatively imperfect instruments, that they will do well to refrain from bringing these forward, until they shall have obtained the opportunity of verifying them with better. It is, as already remarked, when an object is *least* clearly seen, that there is *most* room for the exercise of the imagination; and there was sound sense in the reply once made by a veteran observer, to one who had been telling him of wonderful discoveries which another was said to have made "*in spite* of the badness of his Microscope,"—"No, Sir, it was *in consequence* of the badness of his Microscope." If those who observe, with however humble an instrument, will but rigidly observe the rule of recording only what they can *clearly see*, they can neither go far astray themselves, nor seriously mislead others.

Among the erroneous tendencies which Microscopic enquiry seems especially fitted to correct, is that which leads to the estimation of things by their merely sensuous or material greatness, instead of by their value in extending our ideas

his spirit calm, and his morals perhaps all the more righteous, by spending over his Microscope evenings which would too probably have gradually been wasted at the theatre."

and elevating our aspirations. For we cannot long scrutinize the "world of small" to which we thus find access, without having the conviction forced upon us, that all *size* is but relative, and that *mass* has nothing to do with real grandeur. There is something in the extreme of minuteness, which is no less wonderful,—might it not almost be said, no less majestic—than the extreme of vastness. If the mind loses itself in the contemplation of the immeasurable depths of space, and of the innumerable multitudes of stars and systems by which they are peopled, it is equally lost in wonder and admiration, when the eye is turned to those countless multitudes of living beings which a single drop of water may contain, and when the attention is given to the wondrous succession of phenomena which the life-history of every individual among them exhibits, and to the order and constancy which this presents. Still more is this the case, when we direct our scrutiny to the penetration of that universe which may be said to be included in the body of Man, or of any one of the higher forms of organized being, and survey the innumerable assemblage of elementary parts, each having its own independent life, yet each working in perfect harmony with the rest, for the completion of the wondrous aggregate which the Life of the whole presents. In the study of the one class of phenomena, no less than in the survey of the other, we are led towards that Infinity, in comparison with which the greatest and the least among the objects of Man's regard are equally insignificant; and in that Infinity alone can we seek for a Wisdom to design, or a Power to execute, results so vast and so varied, by the orderly co-operation of the most simple means.

CHAPTER I.

OPTICAL PRINCIPLES OF THE MICROSCOPE.

1. ALL Microscopes in ordinary use, whether *simple* or *compound*, depend for their magnifying power on that influence exerted by lenses in altering the course of the rays of light passing through them, which is termed *refraction*.* This influence takes place in accordance with the two following laws, which are fully explained and illustrated in every elementary treatise on Optics :†

I. A ray of light passing from a rarer into a denser medium, is refracted *towards* a line drawn perpendicularly to the plane which divides them; and *vice versâ*.

II. The *sines* of the angles of *incidence* and *refraction* (that is, of the angles which the ray makes with the perpendicular *before* and *after* its refraction) bear to one another a constant ratio for each substance, which is known as its *index of refraction*.

It follows from the first of these laws, that a ray of light entering any denser medium *perpendicularly*, undergoes *no* refraction, but continues in its straight course; and from the second, that the rays nearest the perpendicular are refracted less than those more distant from it. The 'index of refraction' is determined for different substances, by the amount of the refractive influence which they exert upon rays passing into them, not from air, but from a vacuum; and in expressing it, the sine of the angle of refraction is considered as the *unit*, to which that of the angle of incidence bears a fixed relation. Thus when we say that the 'index of refraction' of Water is 1.336, we mean that the sine of the angle of incidence of a ray passing into water from a vacuum, is to that of the angle of refraction, as 1.336 to 1, or almost exactly as $1\frac{1}{3}$ to 1, or as

* It is not considered necessary in the present Treatise, to describe the *reflecting* Microscope of Amici; since this, although superior to the Microscopes in use previously to its introduction, has been completely superseded by the application of the Achromatic principle to the ordinary Microscope.

† See especially Dr. Golding Bird's "Manual of Natural Philosophy," Chap. xxii.

4 to 3. And thus, the angle of incidence being given, that of the angle of refraction may be found by *dividing* it by the index of refraction.

2. On the other hand, when a ray emerges from a dense medium into a rare one, it is bent *from* the perpendicular, according to the same ratio; and to find the course of the emergent ray, the sine of the angle of incidence must be *multiplied* by the 'index of refraction,' which will give the sine of the angle of refraction.—Now when an emergent ray falls very obliquely upon the surface, the refraction which it would sustain in passing-forth, tending as it does to deflect it still farther from the perpendicular, becomes so great that the ray cannot pass-out at all, and is reflected back from the plane which separates the two media, into the one from which it was emerging. This internal reflection will take place, whenever the product of the sine of the angle of incidence, multiplied by the index of refraction, exceeds the sine of 90° , which is the radius of the circle; and therefore the 'limiting angle,' beyond which an oblique ray suffers internal reflection, varies for different substances in proportion to their respective indices of refraction. Thus, the index of refraction of water being 1.336, no ray can pass out of it into a vacuum,* if its angle of incidence exceed $48^\circ 28'$, since the sine of that angle, multiplied by 1.336, equals the radius; and in like manner, the 'limiting angle' for flint-glass, its index of refraction being 1.60, is $38^\circ 41'$.—This fact imposes certain limits upon the performance of microscopic Lenses; whilst at the same time it enables the optician to make most advantageous use of glass Prisms for the purpose of *reflection*; the proportion of the light which they throw-back being much greater than that returned from the best-polished metallic surfaces, and the brilliancy of the reflected image being consequently higher. Such prisms are of great value to the Microscopist for particular purposes, as will hereafter appear (§§ 40, 41, 57, 60).

3. The lenses employed in the construction of Microscopes are chiefly *convex*; those of the opposite kind, or *concave*, being only used to make certain modifications in the course of the rays passing through convex lenses, whereby their performance

* The reader may easily make evident to himself the internal reflection of water, by nearly filling a wine-glass with water, and holding it at a higher level than his eye, so that he sees the surface of the fluid obliquely from beneath; no object held above the water will then be visible through it, if the eye be placed beyond the limiting angle; whilst the surface itself will appear, as if silvered, through its reflecting back to the eye the light which falls upon it from beneath.

is rendered more exact (§§ 10, 12).—It is easily shown to be in accordance with the laws of refraction already cited, that when a 'pencil' of parallel rays, passing through air, impinges upon a *convex* surface of glass, the rays will be made to converge; for they will be bent towards the centre of the circle, the radius being the perpendicular to each point of curvature. The central or axial ray, as it coincides with the perpendicular, will undergo no refraction; the others will be bent from their original course in an increasing degree, in proportion as they fall at a distance from the centre of the lens; and the effect upon the whole will be such, that they will be caused to meet at a point, called the *focus*, some distance beyond the centre

FIG. 1.

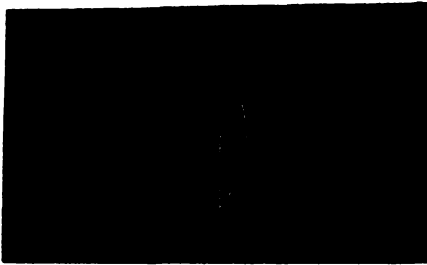

Parallel rays, falling on a *plano-convex* lens, brought to a focus at the distance of its diameter; and conversely, rays diverging from that point, rendered parallel.

of curvature.—This effect will not be materially changed, by allowing the rays to pass into air again through a *plane* surface of glass, perpendicular to the axial ray (Fig. 1); a lens of this description is called a *plano-convex* lens; and it will hereafter be shown to possess properties, which render it very useful in the construction of microscopes. But if, instead of passing through a plane surface, the rays re-enter the air through a second *convex* surface, turned in the opposite direction, as in a *double-convex* lens, they will be made to converge still more. This will be readily comprehended, when it is borne in mind that the contrary direction of the second surface, and the contrary direction of its refraction (this being *from* the denser medium, instead of *into* it), antagonize each other; so that the second convex surface exerts an influence on the course of the rays passing through it, which is almost exactly equivalent to

that of the first. Hence the focus of a *double-convex* lens will be at just half the distance, or (as commonly expressed) will be at half the length, of the focus of a *plano-convex* lens having the same curvature on one side (Fig. 2).

FIG. 2.

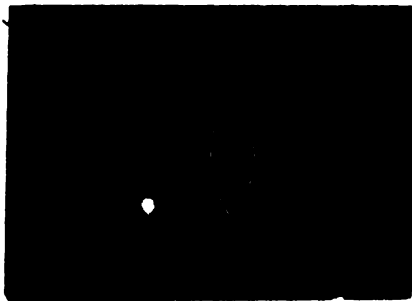

Parallel rays, falling on a *double-convex* lens, brought to a focus in its centre; conversely, rays diverging from that point, rendered parallel.

4. The distance of the *focus* from the lens will depend, not merely upon its degree of curvature, but also upon the refracting power of the substance of which it may be formed; since, the *lower* the index of refraction, the *less* will the oblique rays be deflected towards the axial ray, and the *more remote* will be their point of meeting; and conversely, the *greater* the refractive index, the *more* will the oblique rays be deflected towards the axial ray, and the *nearer* will be their point of convergence. A lens made of any substance whose index of refraction is 1.5, will bring parallel rays to a focus at the distance of its *diameter* of curvature, after they have passed through *one* convex surface (Fig. 1), and at the distance of its *radius* of curvature, after they have passed through *two* convex surfaces (Fig. 2); and as this ratio almost exactly expresses the refractive power of ordinary Glass, we may for all practical purposes consider the 'principal focus' (as the focus for parallel rays is termed) of a *double-convex* lens to be at the distance of its radius, that is, in its centre of curvature, and that of a *plano-convex* lens to be at the distance of twice its radius, that is, at the other end of the diameter of its sphere of curvature.

5. It is evident from what has preceded, that as a double

convex lens brings parallel rays to a focus in its centre of curvature, it will on the other hand cause those rays to assume a parallel direction, which are diverging from that centre before they impinge upon it (Fig. 2); so that, if a luminous body be placed in the principal focus of a double-convex lens, its divergent rays, falling on one surface of the lens as a *cone*, will pass-forth from its other side as a *cylinder*. Again, if rays *already converging* fall upon a double-convex lens, they will be brought together at a point nearer to it than its centre of curvature (Fig. 3); whilst, if the incident

FIG. 3.

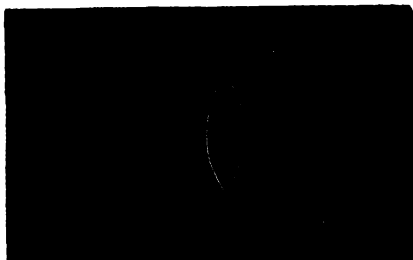

Rays already converging, brought-together at a point nearer than the principal focus; and rays diverging from a point within the principal focus, still diverging, though in a diminished degree.

rays be *diverging* from a distant point, their focus will be more distant from the lens than its principal focus (Fig. 4). The

FIG. 4.



Rays diverging from points more distant than the principal focus on either side, brought to a focus beyond it; if the point of divergence be within the circle of curvature, the focus of convergence will be beyond it; and *vice versd.*

further the point from which they diverge, the more nearly will the rays approach the parallel direction; until, at length, when the object is very distant, its rays in effect become parallel, and are brought together in the principal focus. If the rays which fall upon a double-convex lens, be diverging from the farther extremity of the diameter of its sphere of curvature, they will be brought to a focus at an equal distance on the other side of the lens; but the more the point of divergence is approximated to the centre or principal focus, the further removed on the other side will be the point of convergence, until, the point of divergence being *at* the centre, there is no convergence at all, the rays being merely rendered parallel. If the point of divergence be *within* the principal focus, they will neither be brought to converge nor be rendered parallel, but will diverge in a diminished degree (Fig. 3).—The same principles apply equally to a plano-convex lens; allowance being made for the double distance of its principal focus. They also apply to a lens whose surfaces have different curvatures; the principal focus of such a lens is found by multiplying the radius of one surface by the radius of the other, and dividing this product by half the sum of the same radii.—The rules by which the foci of convex lenses may be found, for rays of different degrees of convergence and divergence, will be found in works on Optics.

6. The refracting influence of *concave* lenses will evidently be precisely the opposite of that of convex. Rays which fall upon them in a parallel direction, will be made to *diverge* as if from the principal focus, which is here called the *negative* focus. This will be, for a plano-concave lens, at the distance of the diameter of the sphere of curvature; and for a double-concave, in the centre of that sphere. In the same manner, rays which are converging to such a degree, that, if uninterrupted, they would have met in the principal focus, will be rendered parallel; if converging more, they will still meet, but at a greater distance; and if converging less, they will diverge as from a negative focus at a greater distance than that for parallel rays. If already diverging, they will diverge still more, as from a negative focus nearer than the principal focus; but this will approach the principal focus, in proportion as the distance of the point of divergence is such, that the direction of the rays approaches the parallel.

7. If a lens be convex on one side and concave on the other, forming what is called a *meniscus*, its effect will depend upon the proportion between the two curvatures. If they

are equal, as in a watch glass, no perceptible effect will be produced; if the convex curvature be the greater, the effect will be that of a less powerful *convex* lens: and if the concave curvature be the more considerable, it will be that of a less powerful *concave* lens. The focus of convergence for parallel rays in the first case, and of divergence in the second, may be found by dividing the product of the two radii by half their difference.

8. Hitherto we have considered only the effects of lenses upon a 'pencil' of rays issuing from a single luminous point, and that point situated in the line of its axis. If the point be situated above the line of its axis, the focus will be below it, and *vice versâ*. The surface of every luminous body may be regarded as comprehending an infinite number of such points, from every one of which a pencil of rays proceeds, and is refracted according to the laws already specified; so that a perfect but inverted image or picture of the object is formed upon any surface placed in the focus, and adapted to receive the rays. It will be evident from what has gone before, that if the object be placed at twice the distance of the principal focus, the image, being formed at an equal distance on the other side of the lens (§ 5), will be of the same dimensions with the object: whilst, on the other hand, if the object (Fig. 5, *a b*) be nearer the lens, the image *A B* will be farther from it, and of larger dimensions; but, if the object *A B* be farther from

. FIG. 5.

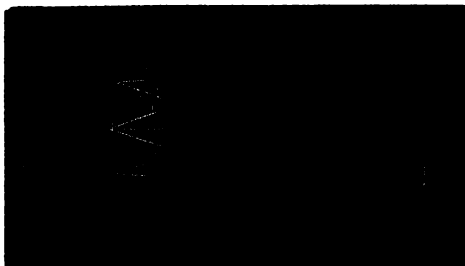

Formation of Images by convex lenses.

the lens, the image *a b* will be nearer to it, and smaller than itself. Further, it is to be remarked, that the larger the image in proportion to the object, the less bright it will be, because the same amount of light has to be spread over a

greater surface; whilst an image that is smaller than the object, will be more brilliant in the same proportion.

9. The knowledge of these general facts will enable us readily to understand the ordinary operation of the Microscope; but the instrument is subject to certain optical imperfections, the mode of remedying which cannot be comprehended without an acquaintance with their nature. One of these imperfections results from the unequal refraction of the rays which have passed through lenses, whose curvatures are equal over their whole surfaces. If the course of the rays passing through an ordinary convex lens be carefully laid-down (Fig. 6), it will be found that they *do not all meet*

FIG. 6.

Diagram illustrating *Spherical Aberration*.

exactly in the foci already stated, but that the focus F of the rays AB, AB , which have passed through the peripheral portion of the lens, is much closer to it than that of the rays ab, ab , which are nearer the line of its axis; so that, if a screen be held in the former, the rays which have passed through the central portion of the lens will be stopped by it before they have come to a focus; and if the screen be carried back into the focus of the latter, the rays which were most distant from the axis will have previously met and crossed, so that they will come to it in a state of divergence, and will pass to c and d . In either case, therefore, the image will have a certain degree of indistinctness; and there is no one point to which all the rays can be brought by a single lens of spherical curvature. The difference between the focal points of the central and of the peripheral rays, is termed the *Spherical Aberration*. It is obvious that, to produce the desired effect, the curvature requires to be increased around the centre of the lens, so as to bring the rays which pass through it more speedily to a focus; and to be diminished towards the circum-

ference, so as to throw the focus of the rays influenced by it to a greater distance. The requisite conditions may be theoretically fulfilled by a lens, one of whose surfaces, instead of being spherical, should be a portion of an ellipsoid or hyperboloid of certain proportions; but the difficulties in the way of the mechanical execution of lenses of this description are such, that, for practical purposes, this plan of construction is altogether unavailable.

9. Various means have been devised for reducing the Aberration of lenses of spherical curvature. It may be considerably diminished, by making the most advantageous use of ordinary lenses. Thus, the aberration of a plano-convex lens, whose convex side is turned towards parallel rays, is only $\frac{17}{100}$ ths of its thickness; whilst, if its plane side be turned towards them, the aberration is $4\frac{1}{2}$ times the thickness of the lens. Hence, in the employment of a plano-convex lens, its convex surface should be turned towards a distant object, when it is used to form an image by bringing to a focus parallel or slightly-diverging rays; but it should be turned towards the eye, when it is used to render parallel the rays which are diverging from a very near object. The single lens having the least spherical aberration, is a double-convex whose radii are as one to six: when its flattest face is turned towards parallel rays, the aberration is nearly $3\frac{1}{2}$ times its thickness; but when its most convex side receives or transmits them, the aberration is only $\frac{7}{120}$ ths of its thickness.—The aberration is further diminished, by reducing the aperture or working-surface of the lens, so as to employ only the rays that pass through the central part, which, if sufficiently small in proportion to the whole sphere, will bring them all to nearly the same focus. The use of this may be particularly noticed in the object-glasses of common (non-achromatic) Microscopes; in which, whatever be the size of the lens itself, the greater portion of its surface is rendered inoperative by a *stop*, which is a plate with a circular aperture interposed between the lens and the rest of the instrument. If this aperture be gradually enlarged, it will be seen that, although the image becomes more and more illuminated, it is at the same time becoming more and more indistinct; and that, in order to gain *defining power*, the aperture must be reduced again. Now this reduction is attended with two great inconveniences; in the first place, the loss of intensity of light, the degree of which will depend upon the quantity transmitted by the lens, and will vary therefore with its aperture; and,

secondly, the diminution of the 'angle of aperture,' that is, of the angle (*abc*, Fig. 8) made by the most diverging of the rays of the pencil issuing from any point of an object, which can enter the lens; on the extent of which angle depend some of the most important qualities of a Microscope (§ 100).

10. The Spherical Aberration may be got-rid-of altogether, however, by making use of *combinations* of lenses, so disposed that their opposite aberrations shall correct each other, whilst magnifying power is still gained. For it is easily seen that, as the aberration of a concave lens is just the opposite of that of a convex lens, the aberration of a convex lens placed in its most favourable position may be corrected by a concave lens of much less power in its most unfavourable position; so that, although the power of the convex lens is weakened, all the rays which pass through this combination will be brought to one focus. It is by a method of this kind, that the Optician aims to correct the spherical aberration, in the construction of those combinations of lenses which are now employed as object-glasses, in all Compound Microscopes that are of any real value as instruments of observation. But it sometimes happens that this correction is not perfectly made; and the want of it becomes evident, in the *fog* by which the distinctness of the image of the object, and especially the precision of its outlines, is obscured.

11. But the spherical aberration is not the only imperfection with which the optician has to contend in the construction of microscopes. A difficulty equally serious arises from the unequal refrangibility of the several coloured rays, which together make-up white or colourless light,* so that they are not all brought to the same focus, even by a lens free from spherical aberration. It is this difference in their refrangibility, which causes their complete separation by the prism into a spectrum; and it manifests itself, though in a less degree, in the image formed by a convex lens. For if parallel rays of white light fall upon a convex surface, the *most* refrangible of its component rays, namely, the *violet*, will be brought to a focus at a point somewhat nearer to the lens than the principal focus, which is the mean of the whole; and the converse will be true of the *red* rays, which are the *least* refrangible, and whose focus will therefore be more distant.

* It has been deemed better to adhere to the ordinary phraseology, when speaking of this fact, as more generally intelligible than the language in which it might be more scientifically described, and at the same time leading to no practical error.

Thus in Fig. 7, the rays of white light, $A B$, $A' B'$, which fall on the peripheral portion of the lens, are so far decomposed, that

FIG. 7.

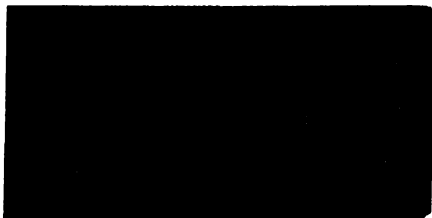

Diagram illustrating Chromatic Aberration.

the violet rays are brought to a focus at c , and crossing there, diverge again and pass on towards $F F$. On the other hand, the red rays are not brought to a focus until D , and cross the diverging violet rays at $E E$. The foci of the intermediate rays of the spectrum (indigo, blue, green, yellow, and orange) are intermediate between these two extremes. If the image be received upon a screen placed at c , the focus of the violet rays, violet will predominate in its own colour, and it will be surrounded by a prismatic fringe in which blue, green, yellow, orange, and red may be successively distinguished. If, on the other hand, the screen be placed at D , the focus of the red rays, the image will have a predominantly-red tint, and will be surrounded by a series of coloured fringes in inverted order, formed by the other rays of the spectrum, which have met and crossed.* The line $E E$, which joins the points of intersection between the red and the violet rays, marks the 'mean focus,' that is, the situation in which the coloured fringes will be narrowest, the 'dispersion' of the coloured rays being the least; whilst the interval $c D$, which separates the foci of the extreme rays, is termed the *Chromatic Aberration* of the lens.—As the axial ray $A' B'$ undergoes no refraction, neither does it sustain any dispersion; and the nearer the rays are to the axial ray, the less dispersion do they suffer. Again, the more oblique the direction of the rays, whether they pass through the central or the peripheral

* This experiment is best tried with a lens of long focus, of which the central part is covered with an opaque stop, so that the light passes only through a peripheral ring; since, if its whole aperture be in use, the regular formation of the fringes is interfered-with by the *spherical* aberration, which gives a different focus to the rays passing through each annular zone.

portion of the lens, the greater will be the refraction they undergo, and the greater also will be their dispersion; and thus it happens that when, by using only the central part of a lens (§ 12), the chromatic aberration is reduced to its minimum, the central part of a picture may be tolerably free from false colours, whilst its marginal portion shall exhibit broad fringes.*

12. The Chromatic Aberration of a lens, like the Spherical, may be diminished by the contraction of its aperture, so that only its central portion is employed. But the error cannot be got-rid-of entirely by any such reduction, which, for the reasons already mentioned, is in itself extremely undesirable. Hence it is of the first importance in the construction of a really-efficient Microscope, that the chromatic aberration of its 'object-glasses' (in which the principal dispersion is liable to occur) should be entirely *corrected*, so that the largest possible aperture should be given to these lenses, without the production of any false colours. No such correction can be accomplished even theoretically in a single lens; but it may be effected by the combination of two or more, advantage being taken of the different relations which the *refractive* and the *dispersive* powers bear to each other in different substances. For if we can unite with a *convex* lens, whose dispersive power is *low* as compared with its refractive power, a *concave* of lower curvature, whose dispersive power is relatively *high*, it is obvious that the dispersion of the rays occasioned by the convex lens may be effectually *neutralized* by the opposite dispersion of the concave (§ 6); whilst the refracting power of the convex is only *lowered* by the opposite refraction of the concave, in virtue of the longer focus of the latter.—No difficulty stands in the way of carrying this theoretical correction into practice. For the 'dispersive' power of *flint-glass* bears so much larger a ratio to its refractive power than does that of *crown-glass*, that a convex lens of the former, the focal length of which is $7\frac{2}{3}$ inches, will produce the same degree of colour as a convex lens of crown-glass, whose focal length is $4\frac{1}{2}$ inches. Hence a concave lens of the former material and curvature, will fully correct the dispersion of a convex lens of the latter; whilst it diminishes its refractive power only to such an extent as to make its focus 10 inches. The correction for chromatic aberration in such a lens would be perfect, if it were not that, although the extreme rays, violet

* This is well seen in the large pictures exhibited by Oxy-hydrogen Microscopes.

and red, are thus brought to the same focus, the dispersion of the rest is not equally compensated; so that what is termed a *secondary spectrum* is produced, the images of objects seen through such a lens being bordered on one side with a purple fringe, and on the other with a green fringe. Moreover such a lens is not corrected for spherical aberration; and it must of course be rendered free from this, to be of any real service, however complete may be the freedom of its image from false colours. This double correction may be accomplished theoretically by the combination of *three* lenses, namely, a double-concave of flint placed between two double-convex of crown, ground to certain curvatures; and this method has long been employed in the construction of the large object-glasses of Telescopes, which are, by means of it, rendered *Achromatic*,—that is, are enabled to exert their Refractive power without producing either chromatic or spherical Aberration.

13. It has only been of late years, however, that the construction of Achromatic object-glasses for Microscopes has been considered practicable; their extremely minute size having been thought to forbid the attainment of that accuracy which is necessary in the adjustment of the several curvatures, in order that the errors of each separate lens which enters into the combination, may be effectually balanced by the opposite errors of the rest. The first successful attempt was made in this direction, in the year 1823, by M. Selligues of Paris; the plan which he adopted being that of the combination of two or more pairs of lenses, each pair consisting of a double-convex of crown-glass, and a plano-concave of flint. In the next year, Mr. Tulley of London, without any knowledge of what M. Selligues had accomplished, applied himself (at the suggestion of Dr. Goring) to the construction of achromatic object-glasses for the microscope; and succeeded in producing a single combination of three lenses (on the telescopic plan), the corrections of which were extremely complete. This combination, however, was not of high power, nor of large angular aperture; and it was found that these advantages could not be gained, without the addition of a second combination. Prof. Amici at Modena, also, who had attempted the construction of microscopic object-glasses as early as 1812, but, despairing of success, had turned his attention to the application of the *reflecting* principle to the Microscope, resumed his original labours on hearing of the success of M. Selligues; and, by working on his plan, he produced, in 1827, an achromatic combination of

three pairs of lenses, which surpassed anything of the same kind that had been previously executed. From that time, the superiority of the plan of combining *three pairs* of lenses (Fig. 8, 1, 2, 3), which should be so adjusted as to correct each other's errors, to the telescopic combinations adopted by Mr. Tully, may be considered to have been completely established; and English opticians, working on this method, soon rivalled the best productions of Continental skill.

14. It was in this country that the next important improvements originated; these being the result of the theoretical investigations of Mr. J. J. Lister,* which led him to the discovery of certain properties in Achromatic combinations, that had not been previously detected. Acting upon the rules which he laid down, practical Opticians at once succeeded in producing combinations far superior to any which had been previously executed, both in wideness of aperture, flatness of field, and perfectness of correction; and continued progress has been since made in the same direction, by the like combination of theoretical acumen with manipulative skill.†

FIG. 8.

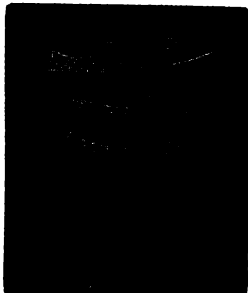

Section of an Achromatic Object-glass.

* See his Memoir in the "Philosophical Transactions," for 1829.

† The first British Opticians (after Mr. Tully) who applied themselves to the construction of Achromatic object-glasses for Microscopes, were Mr. Ross and Mr. Powell. Mr. James Smith did not enter the field until some time afterwards; but, having the advantage of Mr. Lister's special superintendence, he soon equalled, in the lower powers at least, the best productions of his predecessors. With Mr. Ross, his son has been subsequently associated, with Mr. Powell, his brother-in-law, Mr. Lealand; and with Mr. Smith, Mr. Beck, a nephew of Mr. Lister. These three firms have constantly kept-up an honourable rivalry, which has been very advantageous to the *perfectionment* of the Microscope; and have maintained a position which is still far in advance of that of all other manufacturing Opticians in this country or the Continent. The lenses produced by each are distinguished by excellences of their own; and it would be scarcely possible fairly to assign an absolute preference to either above the others.—Among the amateurs who have occupied themselves in the construction of microscopic Achromatics, Mr. Wenham has been the most successful. An American rival has recently been announced, in the person of Mr. Spencer; who, taking advantage of all that had been previously accomplished, is said to have produced combinations not only equalling, but, in some important particulars, surpassing those of English makers. Only one of these, however, has found its way (the Author believes) to this country; and not himself having had the opportunity of seeing it, he can only judge of it by report.

For the subsequent investigations of Mr. Lister have led him to suggest new combinations, which have been speedily carried into practical execution; and there is good reason to believe that the limit of perfection has now been nearly reached, since almost everything which seems theoretically possible has been actually accomplished.—The most perfect combinations at present in use for high powers, consist of as many as *eight* distinct lenses; namely, in front, a triplet composed of two plano-convex lenses of crown-glass, with a plano-concave of dense flint between them; next, a doublet, composed of a double-convex of crown, and a double-concave of flint; and at the back, another triplet, consisting of two double-convex lenses of crown, with a double-concave of flint interposed between them. By the use of this combination, an angular aperture of no less than 170° has been obtained with an objective of 1-12th inch focus; and it is obvious that as an increase of divergence of no more than 10° would bring the extreme rays into a straight line with each other, they would not enter the lens at all; so that no further enlargement of the aperture can be practically useful.

15. The enlargement of the angle of aperture, and the greater completeness of the corrections, first obtained by the adoption of Mr. Lister's principles, soon rendered sensible an imperfection in the performance of these lenses under certain

FIG. 9.



circumstances, which had previously passed unnoticed; and the important discovery was made by Mr. Ross, that a very obvious difference existed in the precision of the image, according as the object is viewed *with* or *without* a covering of talc or thin glass; an object-glass which is perfectly adapted to either of these conditions, being sensibly defective under the other. The mode in which this difference arises, is explained by Mr. Ross as follows.* Let o , Fig. 9, be any point of an object; $o p$ the axial ray of the pencil that diverges from it; and $o t$, $o t'$, two diverging rays, the one near to, the other remote from, the axial ray. Now if $g g g g$ represent the section of a piece of thin glass, intervening between the object and the object-glass, the rays $o t$ and $o t'$ will be refracted in their passage through it, in the directions $t r$, $t' r'$; and on emerging from it again, they will pass-on towards e and e' . Now if the course of these emergent rays be traced backwards, as by the dotted lines, the ray $e r$ will seem to have issued from x , and the ray $e' r'$ from y ; and the distance $x y$ is an aberration quite sufficient to disturb the previous balance of the aberrations of the lens composing the object-glass.—The requisite correction may be effected, as Mr. Ross pointed-out, by giving to the *front* pair (Fig. 8, 1) of the three of which the objective is composed, an excess of positive aberration (*i. e.*, by under-correcting it), and by giving to the other two pairs (2, 3) an excess of negative aberration (*i. e.*, by over-correcting them). and by making the distance between the former and the latter susceptible of alteration. For when the front pair is approximated most nearly to the other two, and its distance from the object is increased, its positive aberration is more strongly exerted upon the other pairs, than it is when the distance between the lenses is increased, and the distance between the front pair and the object is diminished. Consequently, if the lenses be so adjusted that their correction is perfect for an uncovered object, the front pair being removed to a certain distance from the others, its approximation to them will give to the whole combination an excess of positive aberration, which will neutralize the negative aberration occasioned by covering the object with a thin plate of glass.† It is obvious that this correction will be more important to the perfect performance of the combination, the larger is its angle of aperture; since, the wider the divergence of the oblique rays

* "Transactions of the Society of Arts," vol. li.

† The mode in which this adjustment is effected, will be more fitly described hereafter (§ 82).

from the axial ray, the greater will be the refraction which they will sustain in passing through a plate of glass, and the greater therefore will be the negative aberration produced, which will, if uncorrected, seriously impair the distinctness of the image. And it is consequently not required for *low* powers, whose angle of aperture is comparatively small; nor even for the higher, so long as their angle of aperture does not exceed 50° . As a large proportion of the lenses made by foreign Opticians do not range beyond this, the adjustment in question may be dispensed-with; and even where the angle is much larger, if the corrections be made perfect for a thickness of glass of 1-100th of an inch (which is about an average of that with which objects of the finer kind are usually covered), they will not be much deranged by a difference of a few hundredths of an inch, more or less, in that amount.

16. We are now prepared to enter upon the application of the optical principles which have been explained and illustrated in the foregoing pages, to the construction of Microscopes. These are distinguished as *simple*, and *compound*; each kind having its peculiar advantages to the Student of Nature. Their essential difference consists in this;—that in the former, the rays of light which enter the eye of the observer proceed directly from the object itself, after having been subject only to a change in their course; whilst in the latter, an enlarged *image* of the object is formed by a lens, which image is viewed by the observer through a simple microscope, as if it were the object itself. The *simple* microscope may consist of *one* lens; but (as will be presently shown) it may be formed of *two*, or *even* three; these, however, are so disposed as to produce an action upon the rays of light corresponding to that of a single lens. In the *compound* microscope, on the other hand, not less than two lenses must be employed; one to form the enlarged image of the object, and this, being nearest to it, is called the *object-glass*; whilst the other again magnifies that image, being interposed between it and the eye of the observer, and is hence called the *eye-glass*. A perfect object-glass, as we have seen, must consist of a combination of lenses; and the eye-glass, as we shall presently see (§ 21), is best constructed by placing two lenses in a certain relative position, forming what is termed an *eye-piece*.—These two kinds of instrument need to be separately considered in detail.

17. *Simple Microscope*.—In order to gain a clear notion of the mode in which a single lens serves to ‘magnify’ minute objects, it is necessary to revert to the phenomena of ordinary

vision. An eye free from any defect has a considerable power of adjusting itself, in such a manner as to gain a distinct view of objects placed at extremely varying distances; but the image formed upon the retina will of course vary in size with the distance of the object; and the amount of detail perceptible in it will follow the same proportion. To ordinary eyes, however, there is a limit within which no distinct image can be formed, on account of the too great divergence of the rays of the different pencils which then enter the eye; since the eye is usually adapted to receive, and to bring to a focus, rays which are parallel or but slightly divergent. This limit is variously stated at from five to ten inches; we are inclined to think from our own observations, that the latter estimate is nearest the truth; that is, although a person with ordinary vision may see an object much nearer to his eye, he will see little if any more of its details, since what is gained in size will be lost in distinctness. Now the utility of a convex lens interposed between a near object and the eye, consists in its reducing the divergence of the rays forming the several pencils which issue from it; so that they enter the eye in a state of moderate divergence, as if they had issued from an object beyond the nearest limit of distinct vision; and a well-defined picture is consequently formed upon the retina. But not only is the course of the several rays in each pencil altered as regards the rest, by this refracting process, but the course of the pencils themselves is changed, so that they enter the eye under an angle corresponding with that at which they would have arrived from a larger object situated at a greater distance. The picture formed upon the retina, therefore, by any object

FIG. 10.

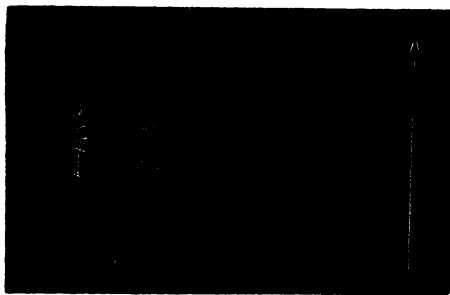
Diagram illustrating the action of the *Simple Microscope*.

(Fig. 10), corresponds in all respects with one which would have been made by the same object ab increased in its dimensions to AB , and viewed at the smallest ordinary distance of distinct vision. A 'short-sighted' person, however, who can see objects distinctly at a distance of two or three inches, has the same power in his eye alone, by reason of its greater convexity, as that which the person of ordinary vision gains by the assistance of a convex lens which shall enable him to see at the same distance with equal distinctness. It is evident, therefore, that the magnifying power of a single lens, depending as it does upon the proportion between the distance at which it renders the object visible, and the nearest distance of unaided distinct vision, must be different to different eyes. It is usually estimated, however, by finding how many times the focal length of the lens is contained in ten inches; since, in order to render the rays from the object nearly parallel, it must be placed nearly in the focus of the lens (Fig. 2); and the picture is referred by the mind to an object at the ordinary distance. Thus, if the focal length of a lens be one inch, its magnifying power for each dimension will be ten times, and consequently a hundred superficial; if its focal distance be only one-tenth of an inch, its magnifying power will be a hundred linear, or ten thousand superficial. The use of the convex lens has the further advantage of bringing to the eye a much greater amount of light, than would have entered the pupil from the enlarged object at the ordinary distance, provided its own diameter be greater than that of the pupil; but this can only be the case when its magnifying power is low.

18. It is obviously desirable, especially when lenses of very high magnifying power are being employed, that their aperture should be as large as possible; since the light issuing from a minute object has then to be diffused over a large picture, and will be proportionally diminished in intensity. But the shorter the focus, the less must be the diameter of the sphere of which the lens forms a part; and unless the aperture be proportionally diminished, the spherical and chromatic aberrations will interfere so much with the distinctness of the picture, that the advantages which might be anticipated from the use of such lenses will be almost negatived. Nevertheless, the Simple Microscope has been an instrument of extreme value in anatomical research, owing to its freedom from those errors to which the Compound Microscope, as originally constructed, was necessarily subject;

the greater certainty of its indications being evident from the fact, that the eye of the observer receives the rays sent-forth by the object itself, instead of those which proceed from an image of that object.—A detail of the means employed by different individuals, for procuring lenses of extremely short focus, though possessing much interest in itself, would be misplaced here; since recent improvements, as will presently be shown, have superseded the necessity of all these. It may be stated, however, that Lœuwenhocck, De la Torre, and others among the older microscopists, made great use of small globules procured by fusion of threads or particles of glass. The most important suggestion for the improvement of the Simple microscope composed of a single lens, proceeded some years ago from Dr. Brewster, who proposed to substitute diamond, sapphire, garnet, and other precious stones of high refractive power, for glass, as the material of single lenses. A lens of much longer radius of curvature might thus be employed, to gain an equal magnifying power; and the aperture would admit of great extension, without a proportional increase in the spherical and chromatic aberrations. This suggestion has been carried into practice with complete success, as regards the performance of lenses executed on this plan; but the difficulties of various kinds in the way of their execution, are such as to render them very expensive; and as they are not superior to the combination now to be described, they have latterly been quite superseded by it.—This combination, first proposed by Dr. Wollaston, and known as his *doublet*, consists of two plano-convex lenses, whose focal lengths are in the proportion of one to three, or nearly so, having their convex sides directed towards the eye, and the lens of shortest focal length nearest the object. In Dr. Wollaston's original combination, no perforated diaphragm (or 'stop') was interposed; and the distance between the lenses was left to be determined by experiment in each case. A great improvement was subsequently made, however, by the introduction of a 'stop' between the lenses, and by the division of the power of the smaller lens between two (especially when a very short focus is required) so as to form a *triplet*, as was first suggested by Mr. Holland.* When combinations of this kind are well constructed, both the spherical and the chromatic aberrations are so much reduced, that the angle of aperture may be considerably enlarged without much sacrifice

* "Transactions of the Society of Arts," vol. xlix.

of distinctness; and hence for all powers above 1-4th inch focus, doublets and triplets are far superior to single lenses. The performance of even the best of these forms of Simple microscope, however, is so far inferior to that of a good Compound microscope as now constructed upon the achromatic principle, that no one who has the command of the latter form of instrument would ever use the *higher* powers of the former. It is for the prosecution of observations, and for the carrying-on of dissections, which only require *low* powers, that the Simple microscope is to be preferred; and consequently although doublets and triplets afforded the best means of obtaining a high magnifying power, before Achromatic lenses were brought to their present perfection, they are now comparatively little used.

19. Another form of simple magnifier, possessing certain advantages over the ordinary double-convex lens, is that commonly known by the name of the 'Coddington' lens. The first idea of it was given by Dr. Wollaston, who proposed to cement together two plano-convex, or hemispherical lenses, by their plane sides, with a stop interposed, the central aperture of which should be equal to 1-5th of the focal length. The great advantage of such a lens is, that the oblique pencils pass, like the central ones, at right angles with the surface; and that they are consequently but little subject to aberration. The idea was further improved-upon by Mr. Coddington, who pointed-out that the same end would be much better answered by taking a sphere of glass, and grinding a deep groove in its equatorial part, which should be then filled with opaque matter, so as to limit the central aperture. Such a lens gives a large field of view, admits a considerable amount of light, and is equally good in all directions; but its powers of definition are by no means equal to those of an achromatic lens, or even of a doublet. This form is chiefly useful, therefore, as a hand magnifier, in which neither high power nor perfect definition is required; its peculiar qualities rendering it superior to an ordinary lens of the same power, for the class of objects for which such lenses are applied in this mode. We think it right to state that many of the magnifiers sold as 'Coddington' lenses are not really (as we have satisfied ourselves) portions of spheres, but are manufactured out of ordinary double-convex lenses, and will be destitute, therefore, of many of the above advantages.—It may be desirable to allude to the magnifier known under the name of the 'Stanhope' lens, which somewhat resembles the 'Coddington'

in appearance, but differs from it essentially in properties. It is nothing more than a double-convex lens, having two surfaces of unequal curvatures, separated from each other by a considerable thickness of glass; the distance of the two surfaces from each other being so adjusted, that when the most convex is turned towards the eye, minute objects placed on the other surface shall be in the focus of the lens. This is an easy mode of applying a rather high magnifying power to scales of butterflies' wings and other similar flat and minute objects, which will readily adhere to the surface of the glass; and it also serves to detect the presence of the larger animalcules, or of crystals in minute drops of fluid, to exhibit the 'eels' in paste or vinegar, &c. &c.; but it is almost entirely destitute of value as an instrument of scientific research, and can scarcely be regarded in any higher light than as an ingenious philosophical toy.*

20. *Compound Microscope*.—In its most simple form, this instrument consists of only two lenses, the 'object-glass' and the 'eye-glass:' the former, CD (Fig. 11), receiving the rays of light direct from the object, AB , which is brought into near proximity to it, forms an enlarged and inverted image $A'B'$ at a greater distance on the other side; whilst the latter, LM , receives the rays which are diverging from this image, as if they proceeded from an object actually occupying its position and enlarged to its dimensions, and these it brings to the eye at E , so altering their course as to make that image appear far larger to the eye, precisely as in the case of the simple microscope (§ 16).—It is obvious that, by the use of the very same lenses, a considerable variety of magnifying power may be obtained, simply by altering their position in regard to each other and to the object; for if the eye-glass be carried further from the object-glass, whilst the object is approximated nearer to the latter, the image $A'B'$ will be formed at a greater distance from it, and its dimensions will consequently be augmented. If on the other hand, the eye-glass be brought nearer to the object-glass, whilst the object is removed further from it, the distance of the image will be shortened, and its dimensions proportionably diminished. We shall hereafter see that this mode of varying the magnifying power of compound microscopes may be turned to good account in more than one mode (§§ 43, 44); but there are limits to the use which can be advantageously made of it. The amplification

* The principal forms of construction of Simple Microscopes; will be described in the next chapter.

may also be varied by altering the magnifying power of the eye-glass; but here, too, there are limits to the increase;

FIG. 11.

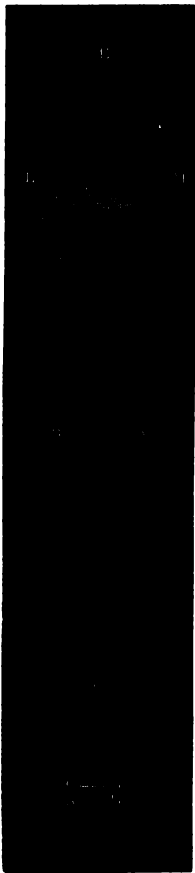

Diagram of simplest form of
Compound Microscope.

FIG. 12.



Diagram of the complete
Compound Microscope.

since defects of the object-glass, which are not perceptible when its image is but moderately enlarged, are brought into injurious prominence when the imperfect image is amplified to a much greater extent. In practice, it is generally found much better to vary the power, by employing object-glasses of different foci; an object-glass of *long* focus forming an image, which is not at many times the distance of the object from the other side of the lens, and which, therefore, is not of many times its dimension; whilst an object-glass of *short* focus requires that the object should be so nearly approximated to it, that the distance of the image is a much higher multiple of that of the object, and its dimensions are proportionably larger (§ 8).—In whatever mode additional amplification be obtained, two things must always result from the change: the portion of the surface of the object, of which an image can be formed, must be diminished; and the quantity of light spread over that image must be proportionably lessened.

21. In addition to the two lenses of which the Compound Microscope essentially consists, another (Fig. 12, F F) is usually introduced between the object-glass and the image formed by it. The ordinary purpose of this lens is to change the course of the rays in such a manner, that the image may be formed of dimensions not too great for the whole of it to come within the range of the eye-piece; and as it thus allows more of the object to be seen at once, it is called the *field-glass*. It is now usually considered, however, as belonging to the ocular end of the instrument,—the *eye-glass* and the *field-glass* being together termed the *Eye-piece*. Various forms of this eye-piece have been proposed by different opticians; and one or another will be preferred, according to the purpose for which it may be required. That which it is most advantageous to employ with Achromatic object-glasses, to the performance of which it is desired to give the greatest possible effect, is termed the ‘Huyghenian;’ having been employed by Huyghens for his telescopes, although without the knowledge of all the advantages which its best construction renders it capable of affording. It consists of two plano-convex lenses (E E and F F, Fig. 12), with their plane sides towards the eye; these are placed at a distance equal to half the sum of their focal lengths; or, to speak with more precision, at half the sum of the focal length of the eye-glass, and of the distance from the field-glass at which an image of the object-glass would be formed by it. A ‘stop’

or diaphragm, $B B$, must be placed between the two lenses, in the visual focus of the eye-glass, which is, of course, the position wherein the image of the object will be formed, by the rays brought into convergence by their passage through the field-glass.—By Huyghens, this arrangement was intended merely to diminish the spherical aberration; but it was subsequently shown by Boscovich, that the chromatic dispersion was also in great part corrected by it. Since the introduction of Achromatic object-glasses for Compound Microscopes, it has been further shown that all error may be avoided by a slight over-correction of these; so that the blue and red rays may be caused to enter the eye in a parallel direction (though not actually coincident), and thus to produce a colourless image. Thus let $L M N$ (Fig. 13) represent the two extreme rays of

FIG. 13.

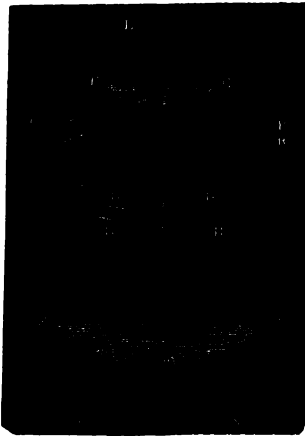

Section of *Huyghenian Eye-piece* adapted to over-corrected Achromatic objectives.

three pencils, which, without the field-glass, would form a blue image convex to the eye-glass at $B B$, and a red one at $R R$; then, by the intervention of the field-glass, a blue image, concave to the eye-glass, is formed at $B' B'$, and a red one at $R' R'$. As the focus of the eye-glass is shorter for blue rays than for red rays, by just the difference in the place of these images, their rays, after refraction by it, enter the eye in a parallel direction, and produce a picture free from false colour. If the object-glass had been rendered perfectly achromatic, the blue rays, after passing through the field-glass, would have been

brought to a focus at b , and the red at r ; so that an error would be produced, which would have been increased instead of antagonised by the eye-glass. Another advantage of a well-constructed Huyghenian eye-piece is, that the image produced by the meeting of the rays after passing through the field-glass, is by it rendered concave towards the eye-glass, instead of

convex, so that every part of it may be in focus at the same time, and the field of view thereby rendered flat.*

22. Two or more Huyghenian eye-pieces, of different magnifying powers, known as Nos. 1, 2, 3, &c., are usually supplied with a Compound Microscope. The utility of the higher powers will mainly depend upon the excellence of the objectives; for when an achromatic combination of small aperture, which is sufficiently well corrected to perform very tolerably with a low eye-piece, is used with an eye-piece of higher magnifying power (commonly spoken-of as a 'deeper' one), the image may lose more in brightness and in definition, than is gained by its amplification; whilst the image given by an objective of large angular aperture and very perfect corrections, shall sustain so little loss of light or of definition by 'deep eye-piecing,' that the increase of magnifying power shall be almost all clear gain. Such an objective, therefore, though of far inferior power in itself, is practically more valuable (as giving a much greater *range* of power with equal efficiency) than a lens of higher power which can only be used effectively with the shallower eye-pieces. Hence the modes in which different achromatic combinations of the same power, whose performance with shallow eye-pieces is nearly the same, are respectively affected by deep eye-pieces, afford a good test of their respective merits; since any defect in the corrections is sure to be brought-out by the higher amplification of the image, whilst a deficiency of aperture is manifested by the want of light.

23. An Eye-piece is sometimes furnished with achromatic microscopes, especially for micrometric purposes, which, though composed of only two plano-convex lenses, differs essentially in its construction from the Huyghenian; the field-glass having its convex side upwards, and being so much nearer to the eye-glass, that the image is not formed above it (as at B B, Fig. 12), but below it. This eye-piece, which is known as Ransden's, gives a very distinct view in the central portion of the field; but, as it does not, like the Huyghenian, correct the convexity of the image formed by the object-glass, but rather increases it, the marginal portions of the field of view, when the centre is in focus, are quite indistinct. Hence this eye-piece cannot be recommended for ordinary use; and

* Those who desire to gain more information upon this subject than they can from the above notice of it, may be referred to Mr. Varley's investigation of the properties of the Huyghenian eye-piece, in the 51st volume of the "Transactions of the Society of Arts;" and to the article 'Microscope,' by Mr. Ross, in the "Penny Cyclopædia."

its chief value to the Microscopist has resulted from its adaptation to receive a divided-glass-micrometer, which may be fitted into the exact plane wherein the image is formed by the object-glass, so that its scale and that image are both magnified together by the lenses interposed between them and the eye. We shall hereafter see, however, that the same end may be so readily attained with the Huyghenian eye-piece (§ 46), that no practical advantage is gained by the use of that of Rausden.—It is affirmed by Mr. Ross, that if the Achromatic principle were applied to the construction of Eye-pieces, the latter is the form with which the greatest perfection would be obtained. That such an adaptation might be productive of valuable results, appears from the success with which Mr. Brooke has employed a triplet objective of one-inch focus, as an eye-piece; the definition obtained by it being very superior to that afforded by the ordinary Huyghenian eye-piece.

24. In the Eye-pieces of compound microscopes of older construction, it was customary to employ a pair of plano or double-convex lenses of longer focus, for the eye-glass, instead of a single plano-convex of shorter focus: the advantage being, that a larger and flatter field could be thereby obtained. A brighter image, a flatter field, and a greater freedom from aberration, than are afforded by any ordinary eye-piece of this kind, may be obtained by the substitution of a combination nearly resembling Herschel's 'aplanatic doublet'—namely, a meniscus, having its concave side next the eye, and a double-convex of the form of least aberration,* with its flattest side next the object—for the plano-convex eye-glass, and the substitution of a double-convex lens of the form of least aberration, with its flattest side next the object, for the plano-convex field-glass. With such an eye-piece, a field of fourteen inches in diameter (measured at the usual distance of ten inches) may be obtained perfectly flat, and equally distinct and well illuminated over every part. When such an eye-piece, however, is used in conjunction with achromatic objectives, it impairs the definition of their image to such a degree, that their finest qualities are altogether sacrificed. Still there are certain large transparent objects, such as transverse sections of wood, wings of insects, &c., in viewing which a large and flat field is of more importance than perfect definition; since their structure is so coarse, that

* The 'form of least aberration' is when the radii of the two surfaces are to each other as 1 to 6.

there is no minute detail to be brought-out. Nothing is so effective for the exhibition of these, as an eye-piece of the kind just alluded-to, with an objective of about 3 or 4 inches focus; and this may either be a single lens (which, when of such low power, will perform sufficiently well for objects of this class), or a single pair of lenses forming part of a perfect achromatic combination, having its aperture somewhat contracted by a stop.*

* Some of the lowest French Achromatics answer extremely well for this purpose; and the front pair of the lowest set usually made in this country (that, namely, of 2 inches focus) is sometimes made removable, so that the back pair which also is very suitable to the class of objects mentioned above, may be employed by itself.

CHAPTER II.

CONSTRUCTION OF THE MICROSCOPE.

25. The *optical* principles whereon the operation of the Microscope depends, having now been explained, we have next to consider the *mechanical* provisions, whereby they are brought to bear upon the different purposes which the instrument is destined to serve. And first it will be desirable to state those general principles, which have received the sanction of universal experience, in regard to the best arrangement of its constituent parts.—Every *complete* Microscope, whether Simple or Compound, must possess, in addition to the lens or combination of lenses which affords its magnifying power, a *stage* whereon the object may securely rest, a *concave mirror* for the illumination of transparent objects from beneath, and a *condensing-lens* for the illumination of opaque objects from above.

1. Now in whatever mode these may be connected with each other, it is essential that *the optical part and the stage should be so disposed, as either to be altogether free from tendency to vibration, or to vibrate together*; since it is obvious that any movement of one, in which the other does not partake, will be augmented to the eye of the observer in proportion to the magnifying power employed. In a badly-constructed instrument, even though placed upon a steady table resting upon the firm floor of a well-built house, when high powers are used, the object is seen to oscillate so rapidly at the slightest tremor, such as that caused by a person walking across the room, or by a carriage rolling-by in the street, as to be frequently almost indistinguishable: whereas in a well-constructed microscope, scarcely any perceptible effect will be produced by even greater disturbances.

11. The next requisite is *a capability of accurate adjustment to every variety of focal distance, without movement of the object*. It is now a principle almost universally recognised in the construction of good Microscopes, that the *stage* whereon the object is placed should be a *fixture*; the movement by which the focus is to be adjusted, being effected in the lenses or

optical portion. Several reasons concur to establish this principle; of which one of the most important is, that, if the stage be made the movable part, the adjustment of the illuminating apparatus must be made afresh for every change of magnifying power; whilst, if the stage be a fixture, the illumination having been once well adjusted, the object may be examined under a great variety of magnifying powers, without its being changed in any respect. Moreover, if the stage be the movable part, it can never have that firmness given to it which it ought to possess; for it is almost impossible to make a movable stage free from some degree of *spring*, so that, when the hands bear upon it in adjusting the position of an object, it yields in a degree, which, however trifling in itself, becomes unpleasantly apparent with high powers. The mode of effecting the focal adjustment should be such as to allow free range from a minute fraction of an inch to three or four inches, with equal power of obtaining a delicate adjustment at any part. It should also be so accurate, that the optical axis of the instrument should not be in the least altered by movement in a vertical direction; so that, if an object be brought into the centre of the field with a low power, and a higher power be then substituted, it should be found in the centre of *its* field, notwithstanding the great alteration in the focus. In this way much time may often be saved, by employing a low power as a *finder* for an object to be examined by a higher one; and when an object is being viewed by a succession of powers, little or no re-adjustment of its place on the stage should be required. For the Simple Microscope, in which it is seldom advantageous to use lenses of shorter focus than 1-11th inch (save where doublets are employed § 18), a *rack-and-pinion* adjustment answers sufficiently well; and this is quite adequate, also, for the focal adjustment of the Compound body, when objectives of low power only are employed. But for any lenses whose focus is less than half an inch, a 'fine adjustment,' by means of a *screw movement* operating either on the object-glass alone or on the entire body, is of great value; and for the highest powers it is quite indispensable. In some Microscopes, indeed, which are provided with a 'fine adjustment,' the rack-and-pinion movement is dispensed-with; the 'coarse adjustment' being given by merely *sliding* the body up and down in the socket which grasps it. But this plan is objectionable, inasmuch as it involves the use of *both* hands in making the 'coarse adjustment,' for which only *one* should be required; and even then

the adjustment cannot be made with nearly the same facility, as by a smooth well-cut rack. The Author's experience, therefore, would lead him to recommend, that if one of these adjustments is to be dispensed-with, it should be the 'screw' or 'fine' adjustment, rather than the 'rack' or 'coarse,' unless the instrument is to be almost exclusively employed for the examination of objects requiring high magnifying powers.*

III. Scarcely less important than the preceding requisite, in the case of the Compound Microscope, though it does not add much to the utility of the Simple, is *the capability of being placed in either a vertical or a horizontal position, or at any angle with the horizon*, without deranging the adjustment of its parts to each other, and without placing the eye-piece in such a position as to be inconvenient to the observer. It is certainly a matter of surprise, that Opticians, especially on the Continent, should have so long neglected the very simple means which are at present commonly employed in this country, of giving an inclined position to microscopes; since it is now universally acknowledged, that the vertical position is, of all that can be adopted, *the very worst*. An inclination of about 55° to the horizon will generally be found most convenient for unconstrained observation; and the instrument should be so constructed, as, when thus inclined, to give to the stage such an elevation above the table, that when the hands are employed at it, the arms may rest conveniently upon the table. In this manner a degree of support is attained, which gives such free play to the muscles of the hands, that movements of the greatest nicety may be executed by them; and the fatigue of long-continued observation is greatly diminished. Such minutiae may appear too trivial to deserve mention; but no practised microscopist will be slow to acknowledge their value. The stage must of course be provided with some means of supporting the object, when it is itself placed in a position so inclined that the object would slip-down unless sustained. There are some objects, however, which can only be seen in a vertical microscope, as they require to be viewed in a position nearly or entirely horizontal; such are

* In the Microscopes constructed by Mr. Ladd, a *chain-movement* is substituted for the rack-and-pinion, and this has the advantage of being smoother and more sensitive, of being less likely to become unequal by wear, and of being easily tightened if it should 'lose time,' whilst its delicacy and smoothness admit of an exact adjustment being made by its means alone, even when high powers are employed. Still, as will be shown hereafter (§ 81), the use of the 'fine adjustment' is by no means restricted to this purpose, and it cannot be advantageously dispensed-with in a Microscope, which is to be used for any but the most common purposes.

dissections in water, urinary deposits, saline solutions undergoing crystallisation, &c. For other purposes, again, the microscope should be placed horizontally, as when the camera lucida is used for drawing or measuring. It ought, therefore, to be made capable of every such variety of position.

IV. The last principle on which we shall here dwell, is *simplicity, in the construction and adjustment of every part*. Many ingenious mechanical devices have been invented and executed, for the purpose of overcoming difficulties which are in themselves really trivial. A moderate amount of dexterity in the use of the hands is sufficient to render most of these superfluous; and without such dexterity, no one, even with the most complete mechanical facilities, will ever become a good microscopist. Among the conveniences of simplicity, the practised Microscopist will not fail to recognise the saving of time effected by being able quickly to set-up and put-away his instrument. Where a number of parts are to be screwed-together before it can be brought into use, interesting objects (as well as time) are not unfrequently lost; and the same cause will often occasion the instrument to be left exposed to the air and dust, to its great detriment, because *time* is required to put it away; so that a slight advantage on the side of simplicity of arrangement, often causes an inferior instrument to be preferred by the working microscopist to a superior one. Yet there is, of course, a limit to this simplification; and no arrangement can be objected-to on this score, which gives advantages in the examination of difficult objects or the determination of doubtful questions, such as no simpler means can afford.—The meaning of this distinction will become apparent, if it be applied to the cases of the “traversing stage” (§ 37) and the “achromatic condenser” (§ 56). For although the traversing stage may be considered a valuable aid in observation, as facilitating the finding of a minute object, or the examination of the entire surface of a large one, yet it adds nothing to the clearness of our view of either; and its place may in great degree be supplied by the fingers of a good manipulator. On the other hand, the use of the achromatic condenser not only contributes very materially, but is absolutely indispensable, to the formation of a perfect image, in the case of many objects of a difficult class; the want of it cannot be compensated by the most dexterous use of the ordinary appliances; and consequently, although it may fairly be considered superfluous, as regards a large proportion of the purposes to which the

Microscope is directed, whether for investigation or for display, yet as regards the particular objects just alluded-to, it must be considered as no less necessary a part of the instrument than the achromatic objective itself. Where expense is not an object, the Microscope should doubtless be fitted with *both* these valuable accessories; where, on the other hand, the cost is so limited that only *one* can be afforded, *that* one should be selected which will make the instrument most useful for the purposes to which it is likely to be applied. (See Introduction, pp. 35, 36).

In the account now to be given, of the principal forms of Microscope readily procurable in this country, it will be the Author's object, not so much to enumerate and describe the various patterns which the several Makers of the instrument have produced, as, by selecting from among them those examples which it seems to him most desirable to make known, and by specifying the peculiar advantages which each of these presents, to guide his readers in the choice of the *kind* of Microscope best suited, on the one hand, to the class of investigations they may be desirous of following-out, and on the other, to their pecuniary ability. He is anxious, however, that he should not be supposed to mark any preference for the particular instruments he has selected, over those constructed upon the same general plan by other Makers; to have enumerated them all, would obviously be quite incompatible with the plan of his treatise; but he has considered it fair (save in one or two special cases) to give the preference to those Makers who have worked-out their own plans of construction, and have thus furnished (to say the least) the general designs, which have been adopted with more or less of modification by others.

Simple Microscope.

26. Under this head, the common *hand-magnifier* or pocket-lens first claims our attention; being in reality a Simple Microscope, although not commonly accounted as such. Although this little instrument is in every one's hands, and is indispensable to the Naturalist,—as affording him the means of at once making such *preliminary* examinations as often afford him most important guidance,—yet there are comparatively few who know how to handle it to the best advantage. The chief difficulty lies in the steady fixation of it at the requisite distance from the object, especially when the

lens employed is of such short focus, that the slightest want of exactness in this adjustment produces evident indistinctness of the image. By carefully resting the hand which carries the glass, however, against that which carries the object, so that both, whenever they move, shall move together, the observer, after a little practice, will be able to employ even high powers with comparative facility. The lenses most generally serviceable for hand-magnifiers, range in focal length from two inches to half an inch; and a combination of two or three of such in the same handle, with an intervening perforated plate of tortoiseshell (which serves as a diaphragm when they are used together), will be found very useful. When such a magnifying power is desired, as would require a lens of a quarter of an inch focus, it is best obtained by the substitution of a 'Coddington' (§ 19) for the ordinary double convex-lens. The handle of the magnifier may be pierced with a hole at the end most distant from the joint by which the lenses are attached to it; and through this may be passed a wire, which, being fitted vertically into a stand or foot, serves for the support of the magnifying lenses in a horizontal position, at any height at which it may be convenient to fix them. Such a little apparatus is a rudimentary form (so to speak) of what is commonly understood as a Simple Microscope; the term being usually applied to those instruments in which the magnifying powers are supported otherwise than in the hand, or, in which, if the whole apparatus be supported by the hand, the lenses have a fixed bearing upon the object (§ 28).

27. *Ross's Simple Microscope.*—This instrument holds an intermediate place between the hand-magnifier and the complete Microscope; being, in fact, nothing else than a lens supported in such a manner, as to be capable of being readily fixed in a variety of positions suitable for dissecting and for other manipulations. It consists of a circular brass foot, wherein is screwed a short tubular pillar (Fig. 14), which is 'sprung' at its upper end, so as to grasp a second tube, also 'sprung,' by the drawing-out of which the pillar may be elongated to about 3 inches. This carries at its upper end a jointed socket, through which a square bar about $3\frac{1}{2}$ inches long slides rather stiffly; and one end of this bar carries another joint, to which is attached a ring for holding the lenses. By lengthening or shortening the pillar, by varying the angle which the square bar makes with its summit, and by sliding that bar through its socket, almost any position and elevation may

be given to the lens, that can be required for the purposes to which it may be most usefully applied; care being taken in

FIG. 14.

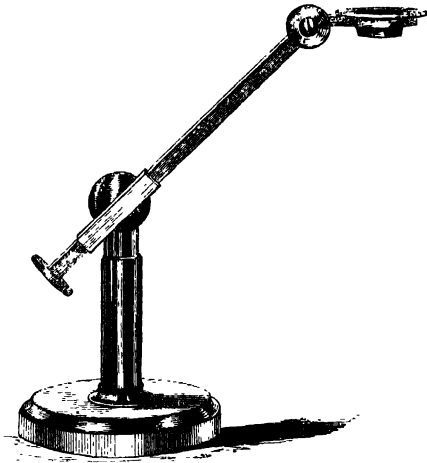

B

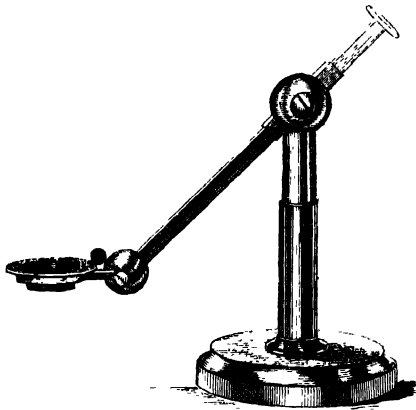

Ross's Simple Microscope.

all instances, that the ring which carries the lens should (by means of its joint) be placed horizontally. At A is seen the position which adapts it best for picking-out minute shells or for other similar manipulations; the sand or dredgings to be examined being spread upon a piece of black paper, and raised upon a book, a box, or some other support, to such a height, that when the lens is adjusted thereto, the eye may be applied to it continuously without unnecessary fatigue. It will be found advantageous that the foot of the microscope should not stand upon the paper over which the objects are spread, as it is desirable to shake this from time to time, in order to bring a fresh portion of the matters to be examined into view; and generally speaking, it will be found convenient to place it on the opposite side of the object, rather than on the same side with the observer. At B is shown the position in which it may be most conveniently set, for the dissection of objects contained in a plate or trough, the sides of which, being higher than the lens, would prevent the use of any magnifier mounted on a horizontal arm.—The powers usually supplied with this instrument, are one lens of an inch focus, and a second of either half or a quarter of an inch. By unscrewing the pillar, the whole is made to pack into a small flat case, the extreme portability of which is a great recommendation. Although the uses of this little instrument are greatly limited by its want of stage, mirror, &c., yet for the class of purposes to which it is suited, it has advantages over perhaps every other form that has been devised.

28. *Gairdner's Simple Microscope*.—This little instrument, distinguished like the preceding for its simplicity and portability, is adapted to quite a different class of purposes; namely, the examination of minute transparent objects, especially those contained in fluid, such as Animalcules, Desmidiæ and Diatomacæe, Urinary deposits, &c. It consists (Fig. 15) of a Wollaston's doublet (§ 18) supported upon a handle, with which is also connected an elastic slip of brass, carrying a ring which surrounds the projecting centre of the under side of the doublet; this ring is made to approach nearer to, or to recede further from, the doublet, by means of a milled-headed screw which passes through the stem that supports the latter, and bears upon the slip of brass that carries the former: and to the side of it which is furthest from the doublet, a disk of very thin glass is cemented. In using this little instrument, a minute drop of the liquid to be examined is to be placed on the *under* side of the thin-glass disk,—that is, on

the side *away* from the doublet,—and it is to be covered

FIG. 15.

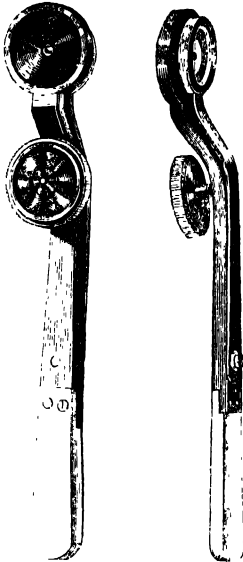

Gairdner's Simple Microscope.

by another disk, which will be drawn to the fixed disk, and supported in its place by the capillary attraction of the fluid for both. The instrument is then to be so held, that the eye, when applied to the doublet, looks at the light through the film of liquid; and when the focal adjustment is made by means of the milled-head, any particles this may contain, of a size to be brought into view by the magnifying power employed, will be distinctly discerned. The instrument is usually constructed with but a single power, adapted to the class of objects for which it is to be employed; thus for the purposes of the botanical or zoological collector, a power of from 70 to 100 diameters is sufficient; whilst for the examination of urinary deposits, a power of 200 or more is desirable. It would

not be difficult so to modify it, however, by making the doublet to screw into a socket, instead of fixing it on the stem, that one power might be substituted for another on the same instrument; and the adjusting screw might then perhaps be dispensed-with, since the focal adjustment might probably be made sufficiently well, by turning round the doublet itself in its screwed socket. The object-holder, too, might be so constructed as to receive a greater variety of objects, and even to hold preparations mounted on slips of glass; which would often be a matter of great convenience for class-demonstration. All this, however, would add to the complexity and the cost of the instrument; the simplicity and low price of which at present constitute its chief recommendation. Though not suited for the higher purposes of a Microscope (the view

of any object afforded by a doublet magnifying 100 or 200 diameters, being far inferior to that presented by only a tolerable achromatic), yet there is a certain class of observations for which it is particularly convenient,—those, namely, which only require a *recognition* of known forms. Thus, the collector of Diatomaceæ, Animalcules, &c., may by its means at once test the general value of the sample he has taken-up, and may decide whether to throw it away as worthless, or to reserve it for more minute examination. And the Medical practitioner who is familiar with the aspect of Urinary deposits, may, by this little instrument (which he can carry in his waistcoat-pocket), discriminate on the spot the nature of almost any sediment whose character he may wish to know, without being obliged to have recourse to a more elaborate apparatus.*

29. *Field's Simple Microscope.*—The *general* purposes of a simple Microscope are satisfactorily answered by the instrument, which has recently gained the premium awarded by the Council of the Society of Arts, and which is capable of being very effectively used in the examination of most of the objects for which such an instrument is suited. It consists (Fig. 16) of a tubular stem, about five inches high, the lower end of which screws firmly into the lid of the box wherein the instrument is packed when not in use. To the upper end of this stem, the stage is firmly fixed; while the lower end carries a concave mirror. Within the tubular stem is a round pillar, having a rack cut into it, against which a pinion works that is turned by a milled-head; and the upper part of this pillar carries a horizontal arm which bears the lenses; so that, by turning the milled-head, the arm may be raised or lowered, and the requisite focal adjustment obtained. Three magnifiers are supplied with this instrument; and by using them either separately or in combination (the lens of shortest focus being placed at the bottom, whenever two, or all three, are used together), a considerable range of powers, from about five to forty diameters, is obtained. The stage is perforated with a hole at each corner; into any one of which may be fitted a condensing lens for opaque objects (§ 61), or a pair of stage-forceps (§ 66). An aquatic-box for the examination of objects in water (§ 68) is also supplied.† This instrument is peculiarly adapted for

* This Microscope, the invention of Dr. William Gairdner, of Edinburgh, is made by Mr. Bryson, optician, of that city.

† The price of the instrument, with all these appurtenances, packed in a neat mahogany box, is only *half-a-guinea*; and the maker, Mr. G. Field of Birmingham, is bound by his agreement with the Society of Arts to keep it always in stock. See also § 31.

educational purposes;* being fitted in every particular for the examination of botanical specimens, small insects or parts

FIG. 16.

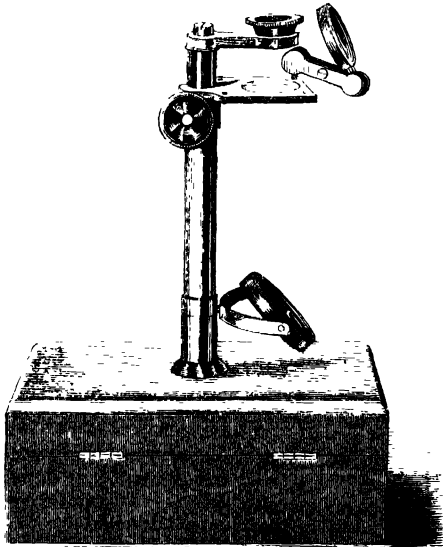

Field's Simple Microscope.

of insects, water-fleas, the larger animalcules, and other such objects as young people may readily collect and prepare for themselves; and such as have trained themselves in the application of it to the study of Nature, are well prepared for the advantageous use of the Compound Microscope. But it also affords to the scientific enquirer all that is essential to the pursuit of such investigations, as are best followed-out by the concurrent employment of a Simple and a Compound Microscope, the former being most fitted for the *preparation*, and the latter for the *examination*, of many kinds of objects;†—and it may be easily adapted to the purposes of dissection, by placing it between arm-rests (§ 104), or blocks

* See Introduction, pp. 33, 34.

† See Introduction, p. 36.

of wood, or books piled one on another, so as to give a support for the hand on either side, at or near the level of the stage.

30. *Quekett's Dissecting Microscope.*—To the scientific investigator, however, it is generally more convenient to have a larger stage than the preceding instrument affords; and in this respect an arrangement devised by Mr. Quekett (Fig. 17) will be

FIG. 17.

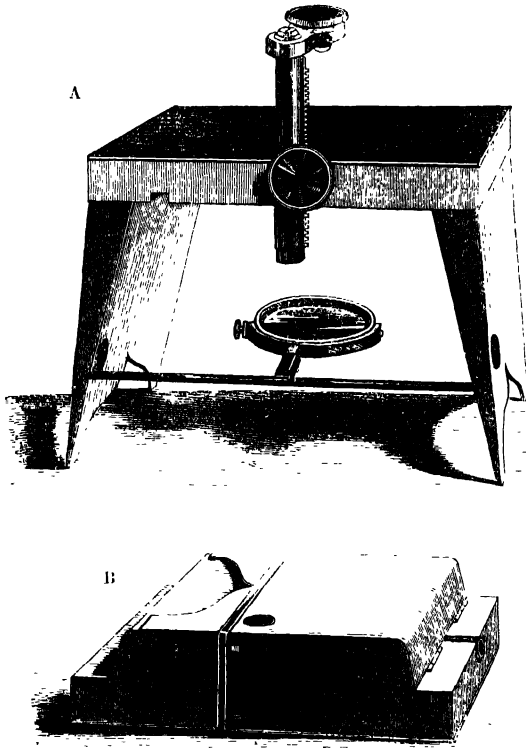

Quekett's Dissecting Microscope.

found extremely convenient. The stage, which constitutes the principal part of the apparatus, is a plate of brass (bronzed) nearly six inches square, screwed to a piece of mahogany of the same size and about 5-8ths of an inch thick; underneath this a folding flap four inches broad is attached by hinges on each side; and the two flaps are so shaped, that, when closed together, one lies closely upon the other, as shown in Fig. 17, B. These flaps, when opened, and kept-asunder by a brass bar, as shown in Fig. 17, A, give a firm support to the stage at a convenient height; and the bar also carries a socket, into which the stem of the mirror-frame is inserted. At the back of the stage-plate is a round hole, through which a tubular stem slides vertically, that carries at its summit the horizontal arm for the magnifying powers; this stem may or may not be furnished with a rack-and-pinion movement; but the author's experience leads him strongly to recommend that it should be provided with this means of making the focal adjustment; since the sliding action, independently of the greater trouble it always involves, is apt to become uneven and difficult, especially if the surface of the stem should have become roughened by the corrosion of sea-water, or by the action of acids, salines, &c., used as reagents. The same frame which carries the mirror, is also made to carry a lens which serves as a condenser for opaque objects; its stem being then fitted into a hole in the stage, at one side, or in front of, its central perforation. The instrument is usually furnished with three magnifiers, namely an inch and half-inch ordinary lenses, and a quarter-inch Coddington (§ 19); and these will be found to be the powers most useful for the purposes to which this instrument is specially adapted. The lenses, mirror, condenser, cross-bar, vertical stem, and milled-head, all fit into hollows cut for their reception on the under side of the stage, and are then covered and kept-in-place by the side-flaps; so that, when packed together, and the flaps kept-down by an elastic band, as shown in Fig. 17, B, the instrument is extremely portable, furnishing (so to speak) a case for itself. It may be easily made to serve as a Compound microscope, by means of an additional stem and horizontal arm, carrying a light 'body.'—The principal disadvantages of this very ingenious and otherwise most convenient arrangement, are that it must be always used with the light *in front* of the observer, or nearly so, since the side-flaps interfere with the access of side-light to the mirror; and that the obstruction of the side-flaps also prevents the hands from having that

ready access to the mirror, which is convenient in making its adjustments. These inconveniences, however, are trifling, when compared with the great facilities afforded for scientific investigation by the size and firmness of the stage; and the Author can confidently recommend the instrument for all such purposes, from much personal experience of its utility.

Compound Microscope.

The various forms of Compound Microscope may be grouped with tolerable definiteness into two principal classes; one consisting of those instruments, whose size and general plan of construction adapt them only for the ordinary methods of observation; whilst the other includes those which are suited to carry the various accessories, whose use enables the observer not only to work with more facility and certainty, but, in some instances, to gain information respecting the object of his examination, which he could not obtain without them. It is true that some of the most important of these accessories *may* be applied to the smaller and lighter kind of Microscopes; but when it is desired to render the instrument complete by the addition of them, it is far preferable to adopt one of those larger and more substantial patterns, which has been devised with express reference to their most advantageous and most convenient employment.—In nearly all the instruments now to be described, the same basis of support is adopted, namely, a triangular ‘foot,’ from which arise two uprights; and between these the microscope itself is swung, in such a manner that the weight of its different parts may be as nearly as possible balanced above and below the centres of suspension, in all the ordinary positions of the instrument. This double support was first introduced Mr. George Jackson, who substituted two pillars (a form which Messrs. Smith and Beek still retain in their Large Compound Microscope, Fig. 29) for the single pillar connected with the microscope itself by a ‘cradle-joint’ (as in Fig. 20) which was previously in use; but in place of pillars screwed into the tripod base, a pair of flattened uprights, cast in one piece with it, is now generally adopted, with a view both to greater solidity and to facility of construction. Messrs. Powell and Lealand, it will be observed, adopt a tripod support of a different kind (Fig. 28), still, however, carrying-out the same fundamental principle, of swinging the microscope itself between two centres.—Two different modes of giving support and motion to the ‘body’ will be found to prevail. One consists in its attachment at its base

to a transverse 'arm,' which is borne on the summit of the movable stem, whose rack is acted-on by the pinion of the milled-head, as in Figs. 18, 27, 28; whilst in the other, the body is supported along a great part of its length by means of a solid 'limb,' to which is attached the pinion that acts on a rack fixed to the body itself, as in Figs. 21, 22, and 29. The former method has the advantage of enabling the body to be turned aside by the rotation of the transverse arm upon the summit of the stem,—a movement which is often convenient, both as leaving the stage clear for dissection, &c., and as enabling the objectives to be more readily exchanged; but it is subject to the disadvantage, that unless the transverse arm and the body are constructed with great solidity, the absence of support along the length of the latter leaves it subject to vibration, which may become unpleasantly apparent when high powers are used, giving a dancing motion to the objects. With a view of preventing this vibration, Messrs. Powell and Lealand connect the top of the 'body' with the back of the transverse arm, by a pair of oblique 'stays' (Fig. 28). The second method of support is decidedly superior in steadiness, a perfect freedom from tremor being obtained with less solidity, and therefore with less cumbrousness; the mode in which the rack is applied, moreover, in the microscopes of Messrs. Smith and Beck (most of which are constructed upon this plan) gives to it a peculiar smoothness and easiness of working; but the traversing movement of the body is sacrificed. Although some attach considerable importance to this movement, the Author's experience of instruments constructed upon both plans, leads him to give a preference to the second.

31. *Field's Compound Microscope.*—The first of the simpler forms which we shall more particularly describe, is that to which the medal of the Society of Arts has been recently awarded, not as a testimony to the *perfection* of its construction, but as marking the highest degree of excellence among the instruments sent in competition, that seemed consistent with the *cheapness** which was the fundamental requirement (See Introduction, p 34). The tripod foot (Fig. 18), with its pair of uprights, is of cast-iron; and affords a very firm and

* The price of this instrument, complete, with two eye-pieces and two achromatic objectives giving a range of power from about 25 to 200 diameters, condenser on a separate stand, stage-forceps, and live-box, in a mahogany case, is only *three guineas*, and the maker, Mr. G. Field of Birmingham, is bound by his agreement with the Society of Arts to keep it always in stock, so as to supply any purchaser at once.

steady basis of support. The centres of suspension by which the microscope is swung between these uprights, are attached

FIG. 18.

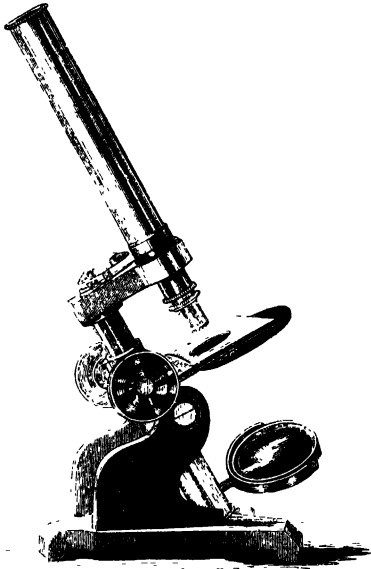

Field's Compound Microscope.

to the hollow pillar that bears all the other parts. Just above them, when the instrument is in a vertical position, is a milled-head on either side, which acts on a rack cut into the stem that rises from the pillar, and carries the body on a transverse arm, thus giving the 'coarse' adjustment for focal distance; whilst the 'fine' adjustment is given by another milled-head (seen edgewise in the figure) in the transverse arm, which turns a screw whose extremity acts upon a lever that produces a slight change in the distance between the object-glass and the object, by elevating or depressing a tube that carries the former,—this tube being so fitted to the lower end of the body as to slide freely within it, and being pressed downwards by a spring, whilst it is raised upwards by the lever-action just named. The additional advantage is

gained by this arrangement (which is the one adopted with some modification by most Microscope-makers), namely, that if the object-glass should be carelessly forced-down so as to press upon the object, the yielding of the spring-tube prevents any serious injury to the one, and to a certain extent protects the other. The stage, which is firmly attached to the pillar, is furnished on its upper surface with a movable brass ledge, against which the object rests when the stage is inclined in any degree to the horizon; this ledge should slide smoothly and easily from the back to the front of the stage, but should have at the same time sufficient hold upon it to retain its position and to support the object, at whatever point it may be left. At a little distance beneath the stage, there is attached to it a 'diaphragm-plate,' perforated with holes of various sizes for the regulation of the quantity of light admitted to transparent objects (§ 55), and also affording, in one of its positions, a dark back-ground, which is useful when opaque objects are being viewed. The stage is perforated at one of its front corners with a hole, into which fits a pair of stage-forceps (§ 66). The mirror, which is concave on one side and plane on the other, is attached, not to the pillar, but to a tube which slides upon it, so that its distance from the under side of the stage may be increased or diminished. The condenser for opaque objects is mounted on a separate stand (§ 61) —The simplicity of the construction of this Microscope, and the facility with which all those adjustments may be made that are required for the purposes which it is intended to fulfil, should constitute, with its low price, a great recommendation to those, who value a Microscope rather as a means of interesting recreation for themselves, or of cultivating a taste for the Study of Nature and a habit of correct observation in the young, than as an instrument of scientific research. It is not, of course, to be expected that it should bear comparison, in regard either to the mechanical finish of its workmanship, or to the perfection of its optical effects, with Microscopes of many times its cost; but it is infinitely superior to the best Microscope ever constructed on the old (non-achromatic) plan; and it is greatly to be preferred in its mechanical arrangements to any of the earlier achromatic microscopes, which it at least equals in optical performance.

32. *Higley's Hospital Microscope.*—The scale of this instrument is somewhat larger than that of the preceding, and its workmanship more finished and substantial. The tripod

stand, the stage and its fittings, and the mirror, almost exactly resemble those first described; but the body, which is longer,

FIG. 19.

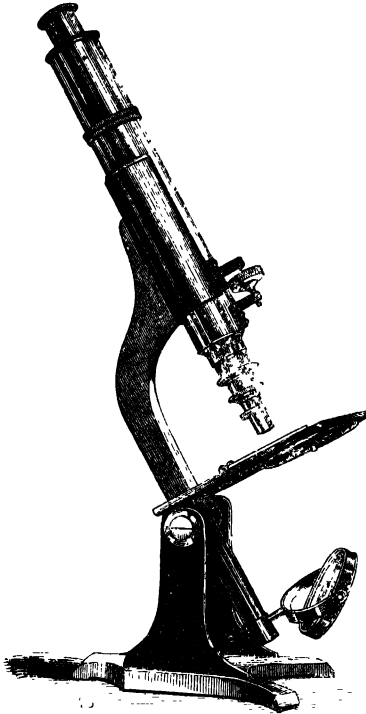

Highley's Hospital Microscope.

is supported in a different manner. The pillar to which the stage and the mirror are attached, is prolonged upwards, and then forms a kind of 'limb,' to which is affixed a tube slit-down in front; and within this tube the 'body' slides up and down, with sufficient freedom to allow of being easily moved, yet with sufficient stiffness to remain firm in any position in which

it may be left. In the simple form of this instrument here delineated, the sliding action affords the only means of making the 'coarse' adjustment (§ 25, 11); but a rack-and-pinion movement may be introduced at a trifling additional cost. The 'fine' adjustment is made by a milled-head in front of the lower end of the body, which acts directly upon a tube sliding within it that carries the objectives.—This instrument is particularly adapted, by the roominess of its stage, for the examination of pathological specimens; and, when the body is provided with a rack movement, it forms an unexceptionable microscope for general purposes, and may even be furnished with a movable stage, achromatic condenser, polarizing apparatus, &c.*

33. *Nachet's Microscope.*—Until a comparatively-recent period, all save the most elaborate and expensive forms of Compound Microscope constructed by Continental opticians, were adapted for use in the vertical position only. M. Nachet, however, has now so modified his ordinary pattern, that the instrument may be inclined (like the preceding) at any angle; and he has thus rendered it a very convenient, as well as a cheap and portable Microscope. The basis consists of a somewhat oval foot, with a single pillar rising from a little behind its centre; and at the top of this pillar is a 'cradle-joint,' which supports the stage and the upright stem that carries the body. The transverse arm, however, is attached, not directly to the summit of this stem, but to a tube which slides over it; and this tube can be raised or lowered by turning the milled-head at its summit (which acts upon a screw that enters the stem), whereby a 'fine' adjustment is obtained, that acts through the transverse arm upon the body which it carries. The 'coarse' adjustment is effected, as in the preceding case, by sliding the body through an outer tube which grasps it; the latter being fixed into the transverse arm. The mode in which the object is supported upon the stage, when this is inclined, is very simple and ingenious, and is in some respects preferable to the sliding-ledge generally used by English makers. Near each side of the stage is seen a somewhat elastic strip or tongue of sheet-brass, the front extremity of which is free, but which is attached at its hinder end to a pin that passes through a hole in the stage, in which it works very easily. This pin is prolonged for about $\frac{3}{4}$ -inch

* The cost of this instrument essentially depends upon the number and magnifying power of the objectives supplied with it; it is usually provided, however, with a 1-inch and $\frac{1}{2}$ -inch; and is then sold (without the rack-movement) at £6 10s. This sum, however, does not include either a case or any accessory apparatus.

beneath the stage, and then terminates in a broad flat head; and it is surrounded by a slender spiral spring, which, bearing

FIG. 20.

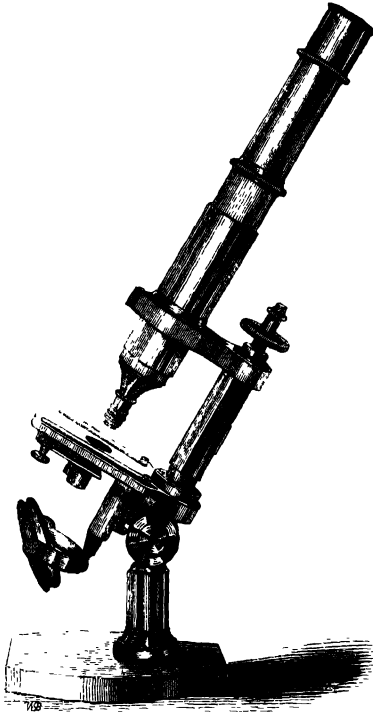

Nachet's Compound Microscope.

at its two ends against the under side of the stage and the head of the pin, tends to depress the latter, and thus to bring the brass tongue into close apposition with the stage when nothing intervenes, and to bind-down anything that may be placed between them. In making use of this little apparatus, it is most convenient to employ both hands, in such a manner

that the thumb and fore-finger of each shall hold one end of the slip of glass whereon is placed the object under examination, whilst one of the other fingers of each hand is used to push-up the head at the end of the pin, so as to lift the tongue from the stage; the slip of glass can then be moved from side to side, or up and down, with the most perfect freedom, and may be firmly secured at any point by ceasing to press upon the heads of the pins, which will then be forced-down by the springs, so as to bring the tongues to bear on the slip of glass. When the microscope is used in a vertical position, for the examination of urinary deposits &c., no means of fixing the object being required, it is convenient to turn the tongues backwards, so as not to occupy any part of the stage. The advantages of this arrangement are the perfect freedom with which the slip of glass can be moved under the objective, either in finding a minute object, or in examining the surface of a larger one; and the facility and exactness with which it is retained at any point, at which it may be desired to fix it. The disadvantages are, the necessity of using both hands to move the object; and the interference of the tongues with the movement of the object from side to side, when it is large enough to require a considerable range; on which last account the plan is unsuited to the use of an aquatic-box. The stage is furnished on its under surface with a diaphragm-plate, not mounted as a wheel, but sliding in a straight line, which is a less convenient arrangement; and to its lower side is also attached a stem that carries the mirror, the distance of which from the stage is not capable of variation.—This instrument is distinguished by its simplicity and cheapness, and by its adaptation to many of the wants of the scientific enquirer.* One of its chief disadvantages is the small size (especially the narrowness) of its stage, which cramps the operations of the observer; and hence it will not be found nearly so convenient to the young microscopist, as the equally-simple patterns in common use in this country. Those, however, who are carrying-on researches upon objects too minute to make this objection felt,—(such, for example, as urinary deposits), and who need high magnifying powers, without requiring these to possess the greatest attainable perfection, will find this Microscope extremely well suited to their wants.—Another instrument constructed by M Nachet upon the same general plan, but upon a larger

* With three objectives and three eye-pieces, giving a range of magnifying powers from about 50 to about 500 diameters, it is sold in Paris for 190 francs.

scale, is capable of being fitted with Achromatic condenser, Polarizing apparatus, Micrometer eye-piece, Stage-movements, &c. ; in the arrangement of which accessories, much skilful contrivance is shown.—The *Binocular Microscope* of the same ingenious Optician will be described further on (§ 40).

34. *Smith and Beck's Student's Microscope*.—Of the patterns yet devised for a microscope of simple construction, which shall yet be capable of answering every essential purpose whether of display or of investigation, that of Messrs. Smith and Beck appears to the Author to be (to say the least) among the best ; and he recommends it with the more confidence, since he has for many years employed one of these Microscopes as his own *working* instrument. There is nothing distinctive in the tripod support, or in the mode in which the microscope itself is suspended between the uprights. But the 'body' rests for a great part of its length upon a 'limb' of solid brass, ploughed into a groove for the reception of the rack, which is attached to the body ; this

FIG. 21.

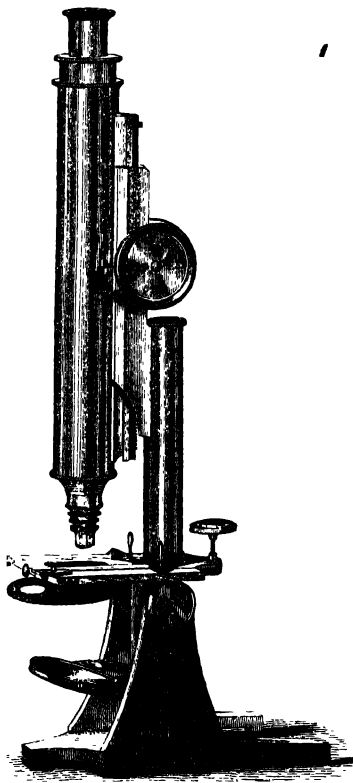

Smith and Beck's Student's Microscope.

groove being of such a form, that the rack is firmly held in it, whilst it slides smoothly through it. The great advantage of this method of construction over any other in which the rack-and-pinion movement is made to act directly on the body, is that it renders impossible any of that *twist* which tends to throw the object more or less completely out of the field, and secures that exact *centering* which is essential to the optical perfection of the instrument. The upper end of the body is furnished with a 'draw-tube,' by which its length can be increased; and one side of this is graduated to inches and tenths. The advantages of this arrangement will be explained hereafter (§ 43). The 'fine' adjustment is effected by means of a milled-head, situated just behind the base of the stem that bears the limb; this acts on a screw, the turning of which (by a contrivance that need not be described in detail) depresses the stem with the limb and body attached to it, so as to bring the objective nearer to the object; whilst if the pressure of the screw be withdrawn, by turning the milled-head in the opposite direction, the tubular stem (with the limb and body) is carried upwards by a spiral spring in its interior, thus increasing the distance of the objective from the object. This adjustment is remarkable for its sensitiveness, and for its freedom from any displacing action upon the image. The only other peculiarity that need be noticed in this instrument, is the mode in which the object is borne upon the stage; for instead of resting against a ledge, it lies upon a kind of fork, which slides in grooves ploughed-out of the stage, and which moves with such facility, that the pressure of a single finger upon one of the upright pins at the back of the fork is sufficient to push it in either direction. At the extremity of one of the prongs of this fork, is a 'spring clip' for securing the object by a gentle pressure, which is particularly useful when the microscope is placed in a horizontal position for drawing with the camera lucida (§ 49), the stage being then vertical. And at the extremity of the other prong is a hole for the insertion of the pin of the stage-forceps, which thus gains the advantage of the sliding movement of the fork, in addition to its own actions.—This instrument can easily be made to receive the addition of an achromatic condenser and of a polarizing apparatus; it *may* also be fitted with a traversing stage, but there is scarcely sufficient room for its working, to render such an addition worth its cost.*

* No working Physiologist or Naturalist can *require*, in the Author's opinion, a better instrument than the above; unless he be directing his

35. *Smith and Beck's Dissecting Microscope*.—A modification of the preceding pattern has been made for the special purpose of carrying-on dissections under the Compound Microscope, without any interference, however, with the use of the instrument for all ordinary purposes. The general plan of the instrument (Fig. 22), as will be at once apparent, is essentially the same as that of the Student's Microscope; but the stage is much longer from back to front, so as to give more room; and from the back of it rises a strong curved limb for the support of the body, which is made to slide upon it, as in the previous case, by a rack-and-pinion movement. A second milled-head is seen above that by which the focal adjustment is made; and this acts by means of a rack upon the draw-tube, which it brings-out or shuts-in, without the necessity of holding the body with the other hand,—a movement which will be found of very great advantage, when the 'erecting eye-piece' (§ 44) is employed for varying the magnifying power. The chief use of this erecting eye-piece, which screws into the lower end of the draw-tube (Fig. 32), in the Dissecting Microscope, is to *erect* the image (as its designation implies), and thus to facilitate the employment of dissecting-instruments upon an object under inspection, the selection of minute shells, &c., or other manipulations, which cannot be so conveniently carried-on, save after long practice, when the object is inverted. As the 'fine' adjustment, cannot, in this pattern, be applied to the 'limb,' it is attached (if required) to the lower end of the body itself, as in Messrs. Smith and Beck's larger Microscope (Fig. 29); but for the purposes to

attention to some particular class of objects, which need the very highest microscopic refinements for their elucidation. The cost of the instrument, fitted with two eye-pieces, condenser for opaque objects, aquatic box, and stage forceps, is (with case) about £7; the cost of the objectives depends upon their magnifying power and upon their angular aperture. Those most serviceable for ordinary purposes are the $1\frac{1}{2}$ inch, $\frac{3}{4}$ inch, $\frac{2}{5}$ inch, and $\frac{1}{2}$ inch, whose respective prices are £3, and 3, 5, and 6 guineas; the first and third, or the second and fourth, of these may be selected in the first instance, and the others added at any time; the addition of the $\frac{1}{2}$ inch (which the unpractised microscopist is scarcely likely to employ to advantage, and which is only useful for a very limited set of purposes) may be postponed until it is really needed and can be effectually employed. More can be seen of most objects by the proper management of such a $\frac{1}{2}$ inch as Messrs. S. and B. now supply, than could have been made-out by the $\frac{1}{2}$ of a few years back.—These opticians are now constructing a new pattern of Students' Microscope, complete in itself with two good powers, which will be well adapted to the most important uses of the Physiologist and Medical Practitioner, without exceeding 10 pounds in price. To those, however, who, though obliged to limit their first outlay, contemplate making subsequent additions, the Author would strongly recommend the choice of the instrument described in the text, as one on which such additional expenditure may be more profitably bestowed.

which such an instrument as this is usually applied, the fine adjustment is seldom needed, the rack-movement being suffi-

FIG. 22.

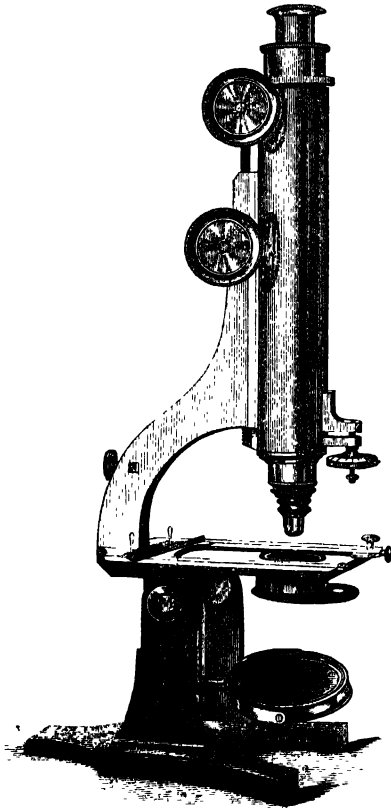

ciently exact and sensitive to furnish all that is needed for low and medium powers. When this addition is made, how-

ever, the instrument is adapted to any kind of work to which the preceding can be applied; it can receive the same fittings; and in consequence of the larger dimensions of the stage, a traversing movement may be readily added to it. This Microscope may thus be rendered a very complete instrument; but it will scarcely be so convenient in use, as the instruments which are specially planned for a greater range of adaptations; and the particular advantage it possesses, is for the purpose indicated by its designation.

36. *Warington's Universal Microscope.*—A new set of adaptations for special purposes, called-for by new requirements, has been recently devised by Mr. Warington; who, by different combinations of the same very simple materials, has produced an instrument which may be used in four different modes, and which may fairly, therefore, be designated a 'universal' microscope. Mr. Warington's original object was to provide an arrangement, whereby the Compound Microscope should be brought to bear upon living objects in an Aquarium, when these might be either in contact with one of the glass sides, or be not far removed from it. This he accomplished by making use of the body of a Student's microscope (§ 34), with the grooved limb in which it slides, and attaching the latter by a strong cradle-joint to a tubular stem, which could be fixed at any height upon the edge of the table

FIG. 23.

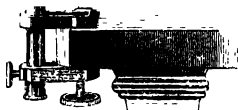
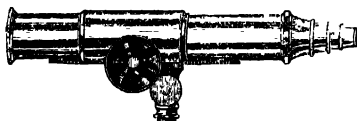

Warington's Universal Microscope, as arranged for viewing objects in an Aquarium.

that supports the Aquarium, by means of a clamp with a binding-screw. Subsequently Mr. W. dispensed with the rack; attaching the cradle-joint at the top of the tubular stem to an outer tube, within which the sliding of the body acts as a 'coarse' adjustment; and providing a 'fine' adjustment (by an ingenious plan of his own) at the object-end of the body itself. To the Author, however, it has seemed far more convenient to retain the rack; and this he has combined with the sliding tube, thus obtaining great facility of adjustment with no perceptible 'twist;' and the arrangement of the apparatus, with this modification, is shown in Fig. 23. If the rack be well cut, there will be no occasion for a 'fine' adjustment; since the purposes to which this arrangement is adapted, only require low or moderate powers. When the instrument is set up in the above position, the body may be moved like a swivel from side to side, and it may be inclined downwards at any degree of obliquity; but its most suitable position will

FIG. 24

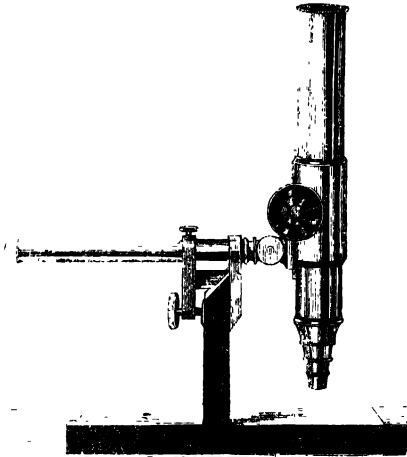

Warington's Universal Microscope, as arranged for Dissection in a large trough. (N.B. By drawing the stem *a* through the clamp, the body may be shifted to such a distance from the wooden base, that the latter need not interfere with the dissecting-trough).

generally be the horizontal, with its axis directed at right angles to the flat side of the Aquarium.—It is obvious that the very same instrument, turned from the horizontal into the vertical position, by attaching the clamp (as in Fig. 24) to the edge of a wooden strutt rising vertically from a horizontal slab, instead of to the edge of a horizontal table, becomes extremely well suited for examining objects which are in course of dissection in a trough too large to be conveniently transferred to the stage of the microscope, for looking-over minute shells spread-out on a sheet of paper, and for other purposes for which a special form of dissecting-microscope has been devised by Messrs. Powell and Lealand.—But again, by turning up the \perp shaped support constructed for the last-named purpose, so that it shall rest (as it were) on two legs like the Greek λ , and then clamping the stem that carries the body to its highest edge, the instrument acquires a position very

FIG. 25.

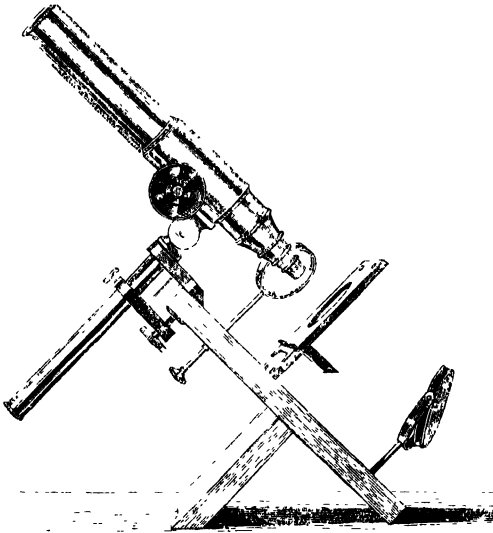

Warington's Universal Microscope, arranged for ordinary use.

suitable for ordinary microscope-work ; and nothing is wanted to adapt it to this, save the addition of a stage and a mirror, each of which may be so constructed as to fit into a brass socket let into the wooden support, thus completing the Microscope in the form represented in Fig. 25.—This is not the last of the adaptations of which the instrument is capable, for the wooden support remaining at the same inclination, the body may be brought to the perpendicular, by shifting its stem in the clamp and by altering its angle at the

FIG. 26.

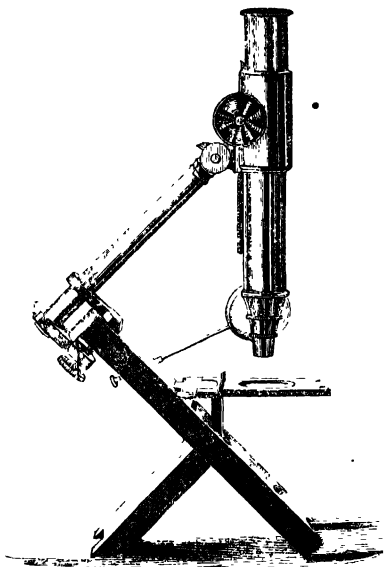

Warrington's Universal Microscope, arranged for dissecting on the stage.

cradle-joint ; whilst a horizontal position may be given to the stage, by fitting it into another socket (Fig. 26) ; in this arrangement, moreover, the stage acquires an increase of firmness, from the bearing of a plate that projects at right angles from its under surface, upon the inclined face of the wooden support. Thus a dissecting-microscope is formed, which has many of the advantages of that of Messrs. Smith and Beck ;

being subject, however, to the important drawback, that the mirror cannot be so placed as to reflect the light upwards through the axis of the microscope. (A means of remedying this, however, might perhaps be contrived without much difficulty or cost.) On the left side of the slanting support, at a short distance above the stage, is a hole into which may be fitted either the stem of a condensing-lens for opaque objects, or the stem of the stage-forceps; either or both of which may also be fitted into holes in the front corners of the stage. The stage is provided with a sliding ledge for the support of objects in an inclined position; and it might also be furnished if required, with a diaphragm-plate. One of the chief merits of the instrument, however, being lightness and portability, it would not be desirable to encumber it with many accessories. For convenience of packing, the shorter portion of the \perp piece may be connected with the longer by strong pins fitted into sockets, instead of being permanently fixed, so that the two can be readily disconnected and one part laid flat upon the other; and the whole apparatus will then lie within a very small compass.—The distinctive peculiarity of this instrument consists in the extreme simplicity of the means, by which a variety of useful ends are obtained. It is scarcely one that should be recommended to the beginner; since it is in several respects not so well adapted for *ordinary* work, as the forms already described. But it is a most valuable addition to the Microscopic apparatus of the Naturalist; and may be constructed at so trifling an expense, to work with any objectives he already may possess, that a considerable demand may be anticipated for it.*

37. We now pass to an entirely-different class of instruments,—those of which the aim is, not simplicity but perfection; not the production of the best effect with limited means, but the attainment of everything that the Microscope *can* accomplish, without regard to cost or complexity. This object has been certainly carried-out by the Opticians of our own country, much more completely than by those of the Continent; and it seems but fair towards the three principal London makers, by whose labours the present admirable results have been attained, that the pattern finally adopted by each should be here delineated and described.—Without any invidious preference, the first place may fairly be assigned to

* This instrument has been made for Mr. Warington and for the Author by Mr. Salmon, 100, Fenchurch-street, who supplies it, on either plan, without objectives or case, but with condenser and stage-forceps, for 3 guineas.

the *Large Compound Microscope of Mr. Ross*; not only as being the one which was first brought (in all essential features at least) to its present form, but also because it is that which contains the greatest number of provisions for investigating objects in a variety of different modes. The general plan of Mr. Ross's Microscope will be seen to be essentially the same with that which has been followed by Mr. Field in the simple

FIG. 27.

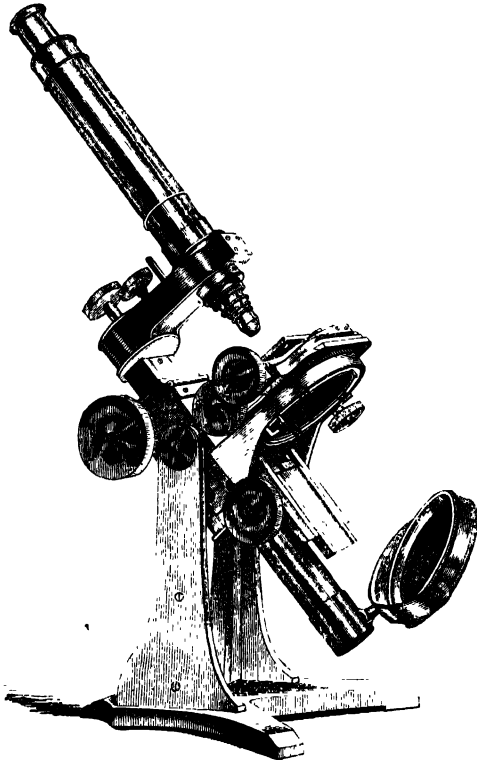

Ross's Large Compound Microscope.

form of this instrument first described (§ 31), as well as by many other makers; but it is carried-out with the greatest attention to solidity of construction, in those parts especially which are most liable to tremor; and we are informed by Mr. Ross, that every part has been tested by the 'inverted pendulum' (an instrument contrived to indicate otherwise insensible vibrations), and either strengthened or reduced as might be found necessary, so as to obtain an *equality of vibration* between the stage and the optical part, which will prevent any perceptible tremor in the image. The 'coarse' adjustment is made by the large milled-head situated just behind the summit of the uprights, which turns a pinion working into a rack cut on the back of a very strong flattened stem, that carries the transverse arm at its summit; a second milled-head (which is here concealed by the stage-fittings) is attached to the other end of the axis of the pinion (as in Fig. 18), so as to be worked with the left hand. The 'fine' adjustment is effected by the milled-head on the transverse arm just behind the base of the 'body;' this acts upon the 'nose' or tube projecting below the arm, wherein the objectives are screwed. The other milled-head seen at the summit of the stem, serves to secure the transverse arm to this, and may be tightened or slackened at pleasure, so as to regulate the traversing movement of the arm; this movement is only allowed to take place in one direction, namely towards the right side, being checked in the opposite by a 'stop,' which secures the coincidence of the axis of the body with the centre of the stage and with the axis of the illuminating apparatus beneath it.—It is in the movements of the stage, that the greatest contrivance is shown; these are three, namely, a traversing movement from side to side, a traversing movement from before backwards, and a rotatory movement. The traversing movements, which allow the platform carrying the object to be shifted about an inch in each direction, are effected by the two milled-heads situated at the right of the stage; and these are placed side by side, in such a position that one may be conveniently acted-on by the fore-finger, and the other by the middle-finger, the thumb being readily passed from one to the other. The traversing portion of the stage carries the platform whereon the object is laid, which has a ledge at the back for it to rest against; and this platform has a sliding movement of its own, from before backwards, by which the object is first brought near to the axis of the microscope, its perfect adjustment being then obtained by the traversing movement. To this

platform, and to the traversing slides which carry it, a rotatory movement is imparted by a milled-head, placed underneath the stage on the left-hand side; for this milled-head turns a pinion which works against the circular rack (seen in the figure) whereby the whole apparatus above is carried-round about a third of a revolution, without in the least disturbing the place of the object, or removing it from the field of the microscope. This rotatory movement is useful for two purposes; first, in the examination of very delicate objects by oblique lights, in order that, without disturbing the illuminating apparatus, the effect of the light and shadow may be seen *in every direction*, whereby important additional information is often gained; and secondly, in the examination of objects under polarized light, a class of appearances being produced by the rotation of the object between the prisms, which is not developed by the rotation of either of the prisms themselves. Below the stage, and in front of the stem that carries the mirror, is a dovetail sliding-bar, which is moved up and down by the milled-head shown at its side; this sliding-bar carries what is termed by Mr. Ross the 'secondary stage' (omitted in the figure for the sake of simplicity), which consists of a cylindrical tube for the reception of the achromatic condenser, the polarizing prism, and other fittings; to this secondary stage, also, a rotatory motion is communicated by the turning of a milled-head; and a traversing movement of limited extent is likewise given to it by means of two screws, one on the front and the other on the left-hand side of the frame which carries it, in order that its axis may be brought into perfect coincidence with the axis of the 'body.'—The special advantages of this instrument consist in its perfect steadiness, in the admirable finish of its workmanship, and in the variety of movements which may be given both to the object and to the fittings of the secondary stage. Its disadvantages consist in the want of portability, necessarily arising from the substantial mode of its construction; and in the multiplicity of its movable parts, which presents to the beginner an aspect of great complexity. This complexity, however, is much more apparent than real; for each of these parts has an independent action of its own, the nature of which is very soon learned; and the various milled-heads are so disposed, that the hand readily (and at last almost instinctively) finds its way from one to the other, so as to make any required adjustment, whilst the eye is steadily directed to the object. To the practised observer, therefore, this multiplica-

tion of adjustments is a real saving of time and labour, enabling him to do perfectly and readily what might otherwise require much trouble, besides affording him certain capabilities which he would not otherwise possess at all.

38. *Powell and Lealand's Compound Microscope.*—This instrument, represented in Fig. 28, is far lighter than the

FIG. 28.

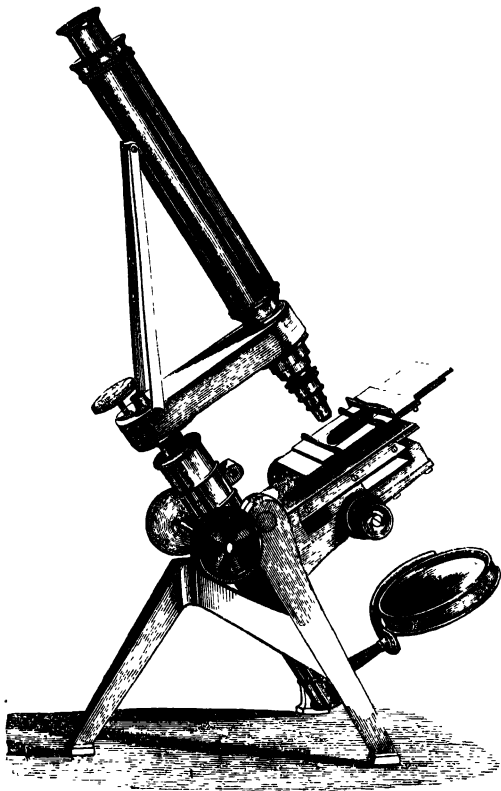

Powell and Lealand's Large Compound Microscope.

preceding in its general 'build,' without being at all deficient in steadiness; it has not, however, some of those movements for which Mr. Ross's plan of construction is especially adapted. The three-legged stand gives a firm support to the trunnions that carry the tube to which the stage is attached, and from which a triangular stem is raised, by the rack-and-pinion movement set in action by the double-milled head, whereby the 'coarse' adjustment of the focus is obtained. The triangular stem carries at its summit the transverse arm, which contains (as in Mr. Ross's microscope) the lever-action of the 'fine' adjustment; and this is acted-on by the milled-head at the back of the arm, whence also pass two oblique stays, which, being attached to the upper part of the body, assist in preventing its vibration. The stage is provided with a traversing movement in each direction, to the extent of about three-quarters of an inch; this is effected on the plan known as Turrell's, in which the two milled-heads are placed on the same axis, instead of side by side, one of them being also repeated on the left hand of the stage, so that the movements may be communicated either by the right hand alone, or by both hands in combination. The platform which carries the object is made to slide, as in the preceding case, on the summit of the traversing apparatus; and it has not only a ledge whereon the object may rest, but also a 'spring-clip' for securing it whenever the stage may be placed in a vertical position. This platform, moreover, is so connected with the traversing apparatus, that it may be turned round in the direction of its plane; but as this rotation takes place above instead of beneath the traversing apparatus, there is no security that the centre of rotation shall coincide with the axis of the optical portion of the instrument; so that, unless this adjustment have been previously made, the object will be thrown completely out of the field of view when the platform is made to revolve. Hence, although this movement is of great use in facilitating the full examination of an object, by enabling the observer to bring it into the field of view in every variety of position, it does not serve, like the rotatory movement of Mr. Ross's stage, to change the position of the object in regard to the illuminating apparatus, without disturbing the observer's view of it. The condenser for transparent objects, the polarizing apparatus, &c., are here fitted to the under side of the principal stage itself, instead of to an independent or secondary stage; an arrangement which, though convenient as regards compactness, admits of less

variety of adjustment than is afforded by the latter plan. The mirror, instead of being swung loosely upon two centres, is pivotted to one end of a quadrant of brass, of which the other end is pivotted to a strong pin that projects from the sliding tube; a spring being so attached to each of these pivots, as to give to the movements of the mirror that suitable degree of stiffness, which shall prevent it from being disturbed by a passing touch.—No instrument can be better adapted than this to all the *ordinary* wants of the Microscopist; there are very few purposes which it cannot be made to answer; and there are many who will consider that its deficiency as to these is counterbalanced (to say the least) by its comparative simplicity and portability, as well as by its lower cost. For the sake, however, of such as may desire the power of obtaining a more oblique illumination, than is permitted by the construction of the stage in the instrument just described, Messrs. P. and L. have recently brought-out a new pattern, in which the thickness of the stage is greatly reduced, a sub-stage is provided for the reception of the condenser and other fittings, and the mirror is mounted on a doubly-extending arm.

39. *Smith and Beck's Large Microscope*.—The general plan of this instrument (Fig. 29) nearly resembles that of the 'dissecting microscope' of the same makers, already noticed (§ 35), so far, at least, as regards the mode of supporting the body, and of effecting the focal adjustments; whilst in the construction of the stage, and in the arrangement of the fittings beneath, it differs from all the microscopes hitherto described. The stage is furnished with the usual traversing movements; but it is distinguished by its *thinness*; and this is of importance in certain cases, as admitting of a more oblique illumination than could otherwise be obtained, and also as allowing the construction of the achromatic condenser (§ 56) to be much simplified. The platform for the object is fitted upon the traversing apparatus, in the same mode as in the microscope last described, and possesses the same kind of rotatory movement. Beneath the stage is a continuation of the gun-metal 'limb' which carries the body; and this is ploughed out into a groove for the reception of a sliding-bar, which carries what may be termed the 'secondary body,' namely, a short tube (seen beneath the stage), capable of being moved up and down by a milled-head, and fitted for the reception of the achromatic condenser, polarizing apparatus, &c. This 'secondary body' consequently answers the same purpose as the 'secondary stage' of Mr. Ross's microscope, and its

relations to the other parts of the instrument are essentially the same; but it differs in the following particulars:—first,

FIG. 29.

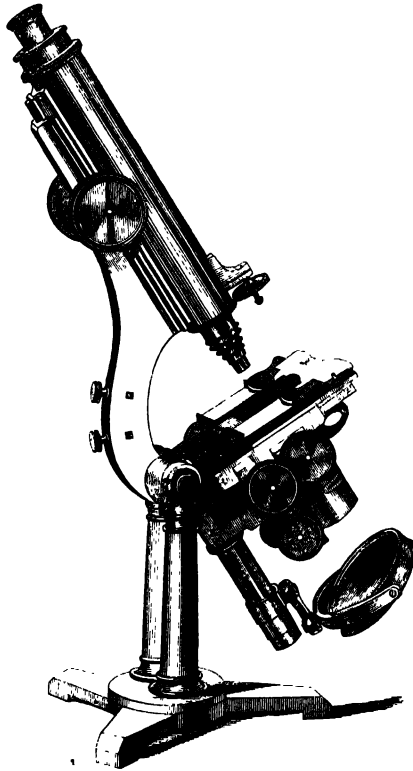

Smith and Beck's Large Compound Microscope.

that by being made to work in a groove which is in perfect correspondence with that wherein the principal 'body' works (this correspondence being secured by the action of the planing machine that ploughs both grooves), the 'secondary' body always has its axis so perfectly continuous with that of the first,

that no special adjustment is needed to 'centre' the greater part of the illuminating apparatus; and secondly, that the tube will carry the achromatic condenser at its upper end, the polarising prism at its lower, and the selenite plates between the two, a combination that cannot be made in any other instrument (§ 63). Moreover, as all these fittings are received into a tube of which the exact size and position are assured, the makers of this instrument can supply additional apparatus at any time, with the certainty of its accurate adjustment. This 'secondary body,' however, has not the rotatory movement possessed by Mr. Ross's 'secondary stage;' and to the limited class of purposes, therefore, which that movement is adapted to serve, it cannot be adapted. The mirror is hung in the usual way between two centres; but the semicircle that carries these, instead of being at once pivotted to the tube which slides upon the cylindrical stem, is attached to an intermediate arm; and by means of this it may be placed in such a position as to reflect light very obliquely upon the object, and thus to bring-out a new set of appearances with which it is very important in certain cases to be acquainted.—In regard to weight and complexity, this instrument holds a position intermediate between the two last described. The mode in which the body is supported, appears to the Author decidedly preferable to that adopted by the other makers; and though it has the disadvantage of separating the focal adjustments from each other and from the stage-motions more widely than is the case in the two preceding instruments, yet the difference is scarcely perceptible in practice. The milled-heads acting on the former are both of them in positions in which they are easily reached by the left-hand, when the elbow is resting on the table; whilst the right-hand finds the milled-heads of the traversing stage and of the secondary body in close proximity to each other. The imperfection of the means of giving rotation to the object, constitutes in this, as in Powell and Lealand's microscope, a point of inferiority to Ross's: the number of cases in which such a movement is important, however, is by no means considerable. On the other hand, the arrangement of the illuminating apparatus in Smith and Beck's Microscope, seems to the Author to present some decided advantages over that adopted by either of the other makers; and in point of general excellence of workmanship, this instrument cannot be surpassed.

Without any invidious comparisons, it may be safely said that whoever desires to possess a *first-class* Microscope,

cannot do better than select one of the three instruments last described; the excellence of the optical performance of the lenses supplied by their respective makers, being so nearly on a par, that the choice may be decided chiefly by the preference which the taste of the purchaser, or the nature of the researches on which he may be engaged, may lead him to entertain, for one or other of the plans of construction which has now been brought under notice.

40. *Nachel's Binocular Microscope*.—Since that remarkable invention of Prof. Wheatstone, the Stereoscope, has led to a general appreciation of the value of *binocular vision*, in conveying to the mind a notion of the *solid forms* of bodies, various attempts have been made to apply the same principle to the Microscope. To any one who understands the principle of the Stereoscope, a little consideration will make it obvious that this end might be *theoretically* attained, by placing two microscope-bodies at such an angle of inclination, that their respective object-glasses should point to the same object, whilst their eye-pieces should be at the ordinary distance of the right and left eyes from each other; but this *practical* difficulty will obviously and necessarily arise, in bringing the two microscopes into the requisite convergence,—that the axes of the instruments cannot be approximated sufficiently-closely at their lower ends, unless the objectives employed should be of a focus so long, that the value of such an instrument would be extremely limited. It was early seen, therefore, that the only feasible method would be to use but a single objective for both bodies; but to bisect the pencils of rays emerging from this lens, so as to cause all those which have issued from the object in such a direction as to pass through either half of it, to be refracted into the body situated on that side; so that the two eyes, applied to the two eye-pieces respectively, shall receive through the two halves of the objective, two magnified images of the object differing from each other in perspective projection, as if the object, actually enlarged to the dimensions of its image, had been viewed by both eyes at once at a moderate distance. That such a method would produce the Stereoscopic effect, might be anticipated from the result of the very simple experiment of covering the right-hand or the left-hand half of an object-glass of low power, during the examination of any object that lies in oblique perspective; for the two views of it thus obtained, will be found to present just the kind and degree of difference which is observable in stereoscopic pictures.—The

first attempt to put this plan into execution, seems to have been that of Prof. Riddell of New Orleans; but the results of his method, as followed by Opticians on the European side of the Atlantic, were far from answering the expectations excited by his own description of them. The subject was both theoretically and practically investigated by Mr. Wenham, with much ability (Transactions of the Microscopical Society, new series, Vol. II., p. 1); and a Binocular Microscope on a pattern suggested by him, was constructed by Messrs. Smith and Beck. This, too, was far from satisfactory in its performance, having two capital defects; namely, first, that the view which it gave was often *pseudoscopic*, the projecting portions of the object appearing to be depressed, and *vice versa*; and second, that the two bodies being united at a fixed angle of convergence, the distance between their axes could not be conveniently adapted to the varying distances of the eyes of different individuals.—The construction adopted by M. Nachet, how-

ever, is much more successful. His method is to divide the pencil of rays issuing from the objective, by means of a prism (Fig. 30, *p*) whose section is an equilateral triangle; for the rays *ab* on the right side, which enter the flattened surface presented to them, are reflected, by impinging very obliquely against one of the internal faces of the prism, towards the left, emerging again from the prism, as they had entered it, almost at right angles; and in like manner, the rays *a'b'* on the left side are reflected towards the right. Each of these pencils is received by a similar prism, which again changes its direction, so as to render

FIG. 30.

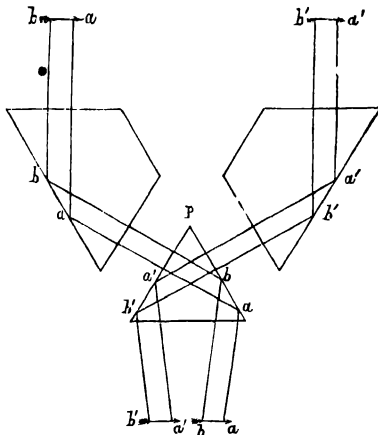

Arrangement of Prisms in Nachet's Binocular Microscope.

it parallel to its original course; and thus the two halves ab and $a'b'$ of the original pencil are completely separated from each other to any interval that may be required, this interval being determined by the distance between the central and the lateral prisms. In Fig. 31 is shown the

FIG. 31.

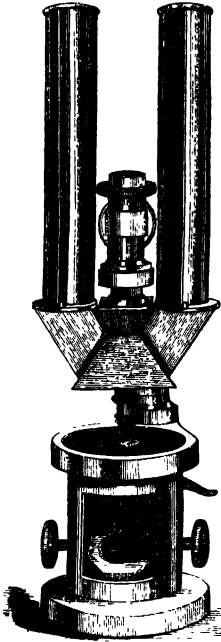

Nachet's Binocular Microscope.

Binocular Microscope constructed by M. Nachet upon this plan. The arrangement of the base and stage is that commonly employed in French vertical Microscopes; and a stem rises from the back of it, with which the double body is connected by a rack-and-pinion movement that gives the focal adjustment. The apparatus of prisms shown in Fig. 30, is placed between the object-glass and the lower ends of the bodies; and by means of a double-threaded screw acted-on by a milled-head between the two bodies, they may be separated from, or approximated towards, each other; so that the distance between their axes may be brought to coincide with the distance between the axes of the eyes of the individual observer.—The Author can confirm by his own experience the statement of M. Nachet, that this instrument is entirely free from that tendency to produce pseudoscopic effects, which is the great drawback in Prof. Riddell's and in Mr. Wenham's arrangements; and it comes so near the theoretical standard of perfection, when used with low

powers of moderate aperture, that its performance may be considered highly satisfactory. Its definition, however, when used with higher powers of larger angular aperture, has not yet been rendered sufficiently good, to enable it to afford a satisfactory view of the more difficult class of test-objects; and it may be doubted whether, considering the number of deflections which the rays undergo in their course, such perfect

definition is to be anticipated. For although their *general* course on entering and emerging from each prism may be perpendicular to its surfaces, so that they suffer no refraction, many of them will be slightly oblique, and will therefore undergo not only refraction, but also some amount of chromatic dispersion. And it is moreover to be recollected, that when high powers are being employed, and especially such as are of large angular aperture, the smallest departure from exactitude in the focal adjustment gives indistinctness to the image. Now the special object of this instrument being to convey to the mind the notion of the *solid forms* of objects, of which some parts project more than others, it is obvious that the rays proceeding from the projecting parts cannot be so nearly brought to the same focus with those from the receding, as to produce an even tolerably-distinct image of both at once. It seems likely to be only with objectives of comparatively low power and small angular aperture, that images suitable for the production of Stereoscopic effects will be produced; but for certain classes of objects, this mode of exhibition is most admirably adapted, the solid forms of the *Polycystina* (Chap. x.), for example, being brought-out by it (especially when they are viewed as opaque, not as transparent objects) with such a reality, as to make them resemble carved ivory balls which the hand feels ready to grasp.

41. The same method of dividing the pencil of rays issuing from the object-glass, by a separating prism placed in its course, has been applied by M. Nachet to another purpose,—that of enabling two or more observers to look at the same object at once, which is often a matter not only of considerable convenience, but also of great importance, especially in the demonstration of dissections. The account given by M. Nachet of the construction of this instrument, as adapted for *two* persons, will be found in the “Quarterly Journal of Microscopical Science,” Vol. II., p. 72; he has subsequently devised another arrangement, by which the form of the separating prism is adapted to divide the pencil into *three* or even *four* parts, each of which may be directed into a different body, so as to give to several observers at one time a nearly identical image of the same object. Of course, the larger the number of secondary pencils into which the primary pencil is thus divided, the smaller will be the share of *light* which each observer will receive; but this reduction does not interfere with the distinctness of the image, and may be in some degree compensated by a greater intensity of illumination.

CHAPTER III.

ACCESSORY APPARATUS.

42. In describing the various pieces of accessory apparatus with which the Microscope may be furnished, it will be convenient in the first place to treat of those which form (when in use) part of the instrument itself, being Appendages either to its Body or to its Stage, or serving for the Illumination of the objects which are under examination; and secondly to notice such as have for their function to facilitate that examination, by enabling the microscopist to bring the Objects conveniently under his inspection.

Section I. *Appendages to the Microscope.*

43. *Draw-Tube.*—It is advantageous for many purposes, that the Eye-piece should be fitted, not at once into the ‘body’ of the Microscope, but into an intermediate tube; the drawing-out of which, by augmenting the distance between the object-glass and the image which it forms in the focus of the eye-glass, still further augments the size of the image in relation to that of the object (§ 20). For although the magnifying power cannot be thus increased with advantage to any considerable extent, yet, if the corrections of the object-glass have been perfectly adjusted, its performance is not seriously impaired by a moderate lengthening of the body; and this may be conveniently had-recourse-to on many occasions, in which some amplification is desired, intermediate between the powers furnished by any two objectives. Thus if one object-glass give a power of 80 diameters, and another a power of 120, by using the first and drawing-out the eye-piece, its power may be increased to 100. Again, it is often very useful to make the object fill up the whole, or nearly the whole, of the field of view: thus if an object that is being viewed by transmitted rays, is so far from transparent as to require a strong light to render its details visible, the distinctness of its details is very much interfered-with, if, through its not occupying the peripheral part of the field, a glare of light enter the eye around its margin; and the importance of this

adjustment is even greater, if opaque objects mounted on black disks are being viewed by the Lieberkuhn (§ 65), since if any light be transmitted to the eye direct from the mirror, in consequence of the disk failing to occupy the entire field, it greatly interferes with the vividness and distinctness of the image of the object. In the use of the Micrometric eye-pieces to be presently described (§§ 45, 46), very great advantage is to be derived from the assistance of the draw-tube; as enabling us to make a precise adjustment between the divisions of the stage-micrometer, and those of the eye-piece micrometer; and as admitting the establishment of a more convenient numerical relation between the two, than could be otherwise secured without far more elaborate contrivances. Moreover, if, for the sake of saving room in packing, it be desired to reduce the length of the body, the draw-tube affords a ready means of doing so; since the body may be made to 'shut-up,' like a telescope, to little more than half its length, without any impairment of the optical performance of the instrument when mounted for use.

44. *Erector*.—It is only, however, in the use of the Erector, that the full value of the draw-tube, and the advantage of giving to it a rack-and-pinion movement of its own (§ 35), come to be fully appreciated. This instrument, first applied to the Compound Microscope by Mr. Lister, consists of a tube about three inches long, having a meniscus at one end and a plano-convex lens at the other (the convex sides being upwards in each case), with a diaphragm nearly half way between them; and this is screwed into the lower end of the draw-tube, as shown in Fig. 32. Its effect is (like the corresponding erector of the Telescope), to antagonize the reversion of the image formed by the object-glass, by producing a second reversion, so as to make the image presented to the eye correspond in position with the object. The passage of the rays through two additional lenses, of course occasions a certain loss of light by reflection from their surfaces, besides subjecting them to aberrations whereby the distinctness of the image is somewhat impaired; but this need not be an obstacle to its

FIG. 32.



Draw-tube fitted with Erector.

use for the class of purposes for which it is especially adapted in other respects (§ 35), since these seldom require a very high degree of defining power.—By the position given to the Erector, it is made subservient to another purpose of great utility; namely the procuring a very extensive *range* of magnifying power, without any change in the objective. For when the draw-tube, with the erector fitted to it, is completely pushed-in, the *acting length* of the body (so to speak) is so greatly reduced by the formation of the first image much nearer the objective, that, if a lens of 8-10ths of an inch focus be employed, an object of the diameter of $1\frac{1}{2}$ inch can be taken-in, and enlarged to no more than 4 diameters; whilst, on the other hand, when the tube is drawn-out to its whole length, the object is enlarged 100 diameters. Of course every intermediate range can be obtained, by drawing-out the tube more or less; and the facility with which this can be accomplished, renders such an instrument most useful in various kinds of research, especially those in which it is important, after *finding* an object with a low power, to *examine* it under a higher amplification; since this may be done, without either a change of objectives, or a transfer of the object to another microscope fitted with a different power. It is when the draw-tube is thus made subservient to the use of the Erector, that the value of its rack-and-pinion adjustment is most felt; for by giving motion to the milled-head which acts upon this (Fig. 22) with one hand, whilst the other hand is kept upon the milled-head which moves the whole body (it being necessary to shorten the distance between the object and the objective, in proportion as the distance of the image from the objective is increased), the observer—after a little practice in the working-together of the two adjustments—may almost instantaneously alter his power to any amount of amplification which he may find the object to require, without ever losing a tolerably distinct view of it. This can scarcely be accomplished without the rack-movement; since, if both hands be required to make the alteration of the draw-tube, the re-adjustment of the focus must be effected subsequently.

45. *Micrometer*.—Although some have applied their micrometric apparatus to the stage of the microscope, yet it is to the Eye-piece that it may be most advantageously adapted.*

* The Stage-micrometer constructed by Fraunhofer is employed by many continental Microscopists; but it is subject to this disadvantage,—that any error in its performance is augmented by the *whole* magnifying power employed; whilst a like error in the Eye-piece-micrometer is increased by the magnifying power of the eye-piece alone.

The *cobweb micrometer*, invented by Ramsden for Telescopes, is probably, when well constructed, the most perfect instrument that the Microscopist can employ. It is made by stretching across the field of a 'positive' eye-piece (§ 23) two very delicate parallel wires or cobwebs, one of which can be separated from the other by the action of a fine-threaded screw, the head of which is divided at its edge into a convenient number of parts, which successively pass-by an index as the milled-head is turned. A portion of the field of view on one side is cut-off at right angles to the cobweb-threads, by a scale formed of a thin plate of brass having notches at its edge, whose distance corresponds to that of the threads of the screw, every fifth notch being made deeper than the rest for the sake of ready enumeration. The object being brought into such a position that one of its edges seems to touch the stationary thread, the other thread is moved by the micrometer-screw, until it appears to lie in contact with the other edge of the object; the number of entire divisions on the scale shows how many complete turns of the screw must have been made in thus separating the threads; while the number to which the index points on the milled-head, shows what fraction of a turn may have been made in addition. It is usual, by employing a screw of 100 threads to the inch, to give to each division of the scale the value of 1-100th of an inch, and to divide the milled-head into 100 parts; but the *absolute* value of the divisions is of little consequence, since their micrometric value depends upon the objective with which the instrument may be employed. This must be determined by means of a ruled slip of glass laid upon the stage; and as the distance of the divisions even in the best-ruled slip is by no means uniform,* it is advisable to take an average of several measurements, both upon different slips, and upon different parts of the same slip. Here the draw-tube will be of essential use, in enabling the microscopist to bring the value of the divisions of his Micrometer to *even numbers*. Thus, suppose that with a 1-4th inch object-glass, the tube being pushed-in, a separation of the lines by one entire turn and 37-100ths of another were needed to take-in the space between two lines on the ruled slip, whose actual distance is 1-1000th of an inch; then it is obvious that 137 divisions on the milled-head

* Of the degree of this inequality, some idea may be formed from the statement of Hannover, that the value of the different divisions of a glass ruled by Chevalier to 1-100th of a millimetre, varied between the extreme ratios of 31:36, the mean of all being 34.

are equivalent with that power to a dimension of 1-1000th of an inch, or the value of each division is 1-137,000th of an inch. But as this is an awkward number for calculation, the magnifying power may be readily increased by means of the draw-tube, until the space of 1-1000th of an inch shall be represented by a separation of the cobweb-threads to the extent of 150 divisions; thus giving to each division the much more convenient value of 1-150,000th of an inch. The Microscopist who applies himself to researches requiring micrometric measurement, should determine the value of his Micrometer with each of the objectives he is likely to use for the purpose; and should keep a table of these determinations, recording in each case the extent to which the tube has been drawn-out, as marked by the graduated scale of inches which it should possess. The accuracy with which measurements may be made with this instrument, is not really quite so minute as it appears to be; for it is found practically that when the milled-head is so graduated, that, by moving it through a single division, the cobweb-threads are separated or approximated by no more than 1-10,000th of an inch, it needs to be moved through *four* divisions, for any change in the position of the threads to be made sensible to the eye. Consequently, if three entire turns, or 300 divisions, were found to separate the threads so far as to coincide with a distance of 1-1000th of an inch on the ruled glass under a 1-8th of an inch objective, although each division of the milled-head, will thus represent 1-300,000th of an inch, yet the smallest measurable space will be four times that amount, or 1-75,000th of an inch. With the 1-12th inch objective, the smallest measurable space may be about 1-100,000th of an inch.

46. The expensiveness of the cobweb-micrometer being an important obstacle to its general use, a simpler method is more commonly adopted, which consists in the insertion of a transparent scale into the focus of the eye-piece, on which the image of the object is seen to be projected. By Mr. Ross, who first devised this method, the 'positive' eye-piece was employed, and a glass plate ruled in squares was attached beneath its field-glass, at such a distance that it and the image of the object should be in focus together; and the value of these squares having been determined with each of the objectives, in the manner already described, the size of the object was estimated by the proportion of the square that might be occupied by its image. While the use of the positive

eyepiece, however, renders the definition of the ruled lines peculiarly distinct, it impairs the definition of the object; and the 'negative' or common Huyghenian eye-piece is now generally preferred. The arrangement devised by Mr. G. Jackson allows the divided glass to be introduced into the ordinary eye-piece (thus dispensing with the necessity for one specially adapted for micrometry), and greatly increases the facility and accuracy with which the eye-piece scale may be used. This scale is ruled like that of an ordinary measure (*i.e.*, with every tenth line *long*, and every fifth line half its length), on a slip of glass, which is so fitted into a brass frame (Fig. 33, A),

FIG. 33.

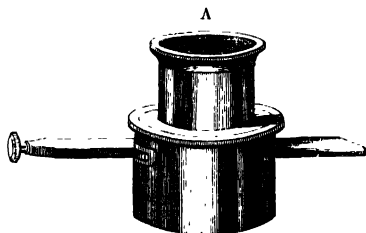

Mr Jackson's Eye-piece Micrometer.

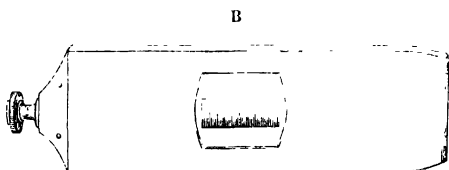

as to have a slight motion towards either end; one of its extremities is pressed-upon by a small fine milled-headed screw which works through the frame, and the other by a spring (concealed in the figure) which antagonizes the screw. The scale thus mounted is introduced through a pair of slits in the eye-piece tube, immediately above the diaphragm (Fig. 33, A), so as to occupy the centre of the field; and it is brought accurately into focus by unscrewing the glass nearest to the eye, until the lines of the scale are clearly seen. The value of the divisions of this scale must be determined, as in

the former instance, by means of a ruled stage-micrometer, for each objective employed in micrometry (the drawing-out of the eye-piece tube enabling the proportions to be adjusted to even and convenient numbers); and this having been accomplished, the scale is brought to bear upon the object to be measured, by moving the latter as nearly as possible into the centre of the field, and then rotating the eye-piece in such a manner, that the scale may lie across that diameter which it is desired to measure. The pushing-screw at the extremity of the scale being then turned, until one edge of the object is in exact contact with one of the long lines, the number of divisions which its diameter occupies is at once read-off by directing the attention to the other edge,—the operation, as Mr. Quekett justly remarks, being nothing more than laying a rule across the body to be measured. This method of measurement may be made quite exact enough for all ordinary purposes, provided, in the first place, that the eye-piece scale be divided with a fair degree of accuracy, and secondly, that the value of its divisions be ascertained (as in the case of the cobweb-micrometer) by *several* comparisons with the scale laid upon the stage. Thus if, by a mean of numerous observations, we establish the value of each division of the eye-piece scale to be 1-12,500th of an inch, then, if the image of an object be found to measure $3\frac{1}{2}$ of those divisions, its real diameter will be $3\frac{1}{2} \times \frac{1}{12500}$ or 1-3571st of an inch.* Now as, with an objective of 1-12th inch focus, the value of the divisions of the eye-piece scale may be reduced to 1-25,000th of an inch, and as the eye can estimate a fourth part of one of the divisions with tolerable accuracy, it follows that a magnitude of as little as 1-100,000th of an inch can be measured with a near approach to exactness, and that this instrument cannot be fairly considered as ranking much below the cobweb-micrometer in minute accuracy. At any rate, it is sufficiently precise (when due care is employed) for all ordinary purposes; and it has the great advantage of cheapness and simplicity.—Whatever method be adopted, if the measurement be made in the Eye-piece, and not on the stage, it will be necessary to make allowance for the adjust-

* The calculation of the dimensions is most simplified by the adoption of a decimal scale; the value of each division being made, by the use of the draw-tube adjustment, to correspond to some aliquot part of a ten-thousandth or a hundred-thousandth of an inch, and the dimensions of the object being then found by simple multiplication:—Thus (to take the above example) the value of each division in the decimal scale is '00008, and the diameter of the object is '00028.

ment of the object-glass to the thickness of the glass that covers the object, since its magnifying power is considerably affected by the separation of the front pair of lenses from those behind it (§ 83). It will be found convenient to compensate for this alteration, by altering the draw-tube in such a manner as to neutralize the effect produced by the adjustment of the objective; thus giving one uniform value to the divisions of the eye-piece scale, whatever may be the thickness of the covering-glass: the amount of the alteration required for each degree must of course be determined by a series of measurements with the stage-micrometer, and should be recorded on the table of the micrometric values of the several objectives.

47. *Goniometer*.—When the Microscope is employed in researches on minute crystals, a means of measuring their angles is provided by the adaptation of a goniometer to the eye-piece. The simplest form (contrived by Schmidt and made by Ross) which answers sufficiently well for all ordinary purposes, essentially consists merely of a 'positive' eye-piece, with a single cobweb-thread stretched across it diametrically in a circular frame capable of rotation; the edges of this frame are graduated in degrees, and a vernier is also attached to the index, whereby fractional parts of degrees may be read-off. By rotating the frame carrying the thread, so that it shall lie successively in the directions of the two sides of the crystal, the angle which they form is at once measured by the difference of the degrees to which the index points on the two occasions. For the cobweb-thread, a glass plate, ruled with parallel lines at about the 1-50th of an inch asunder, may be advantageously substituted; since it is not then necessary to bring the crystal into such a position as to lie along the diametrical thread, but its angle may be measured by means of any one of the lines to which it happens to be nearest.—If a higher degree of precision be required than this instrument is fitted to afford, the *Double-refracting Goniometer*, invented by Dr. Leeson, may be substituted; for a description of which (too long to be introduced here) the reader is referred to Dr. L's account in the "Proceedings of the Chemical Society," Part xxxiii., and to Mr. Quekett's "Practical Treatise on the Microscope."

48. *Indicator*.—When the Microscope is used for the purpose of demonstrating to others such objects as may not be at once distinguished by the uninitiated eye, it is very useful to introduce into the eye-piece, just over the diaphragm, a small steel hand pointing to nearly the centre of the field;

to whose extremity the particular portion of the image which the observer is intended to look-at, is to be brought by moving the object. The hand may be so attached, as to be readily turned-back when not required; leaving the field of the eye-piece quite free. This little contrivance, which was devised by Mr. J. Quekett, is appropriately termed by him the *indicator*.

49. *Camera Lucida*.—Various contrivances may be adapted to the eye-piece, in order to enable the observer to see the image projected upon a surface whereon he may trace its outlines. The one most generally employed is the *Camera Lucida prism* contrived by Dr. Wollaston for the general purposes of delineation; this being fitted on the front of the eye-piece, in place of the 'cap' by which it is usually surmounted. The Microscope being placed in a horizontal position, as

FIG. 34

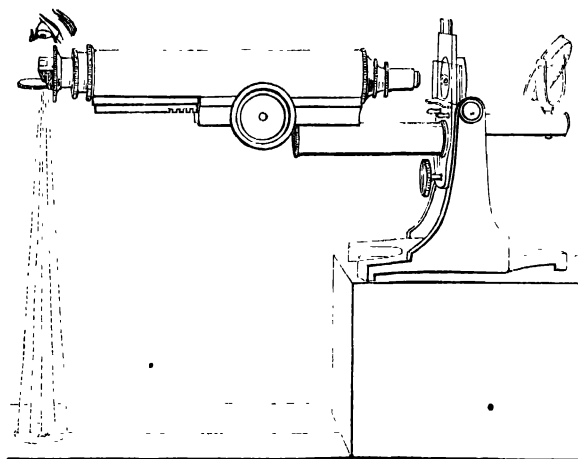

Microscopæ arranged with Camera Lucida for Drawing or Micrometry.

shown in Fig. 34, the rays which pass through the eye-piece into the prism, sustain such a total reflection from its oblique surface, that they come to its upper horizontal surface at right angles to their previous direction; and the eye being so placed over the edge of this surface, that it receives these rays from the prism through part of the pupil, whilst it looks

beyond the prism, down to a white-paper surface on the table, with the other half, it sees the image so strongly and clearly projected upon that surface, that the only difficulty in tracing it arises from a certain incapacity which seems to exist in some individuals, for seeing the image and the tracing-point at the same time. This difficulty (which is common to all instruments devised for this purpose) is lessened by the interposition of a slightly-convex lens in the position shown in the figure, between the eye and the paper, in order that the rays from the paper and tracing-point may diverge at the same angle as those which are received from the prism; and it may be generally got-over altogether, by experimentally modifying the relative degrees of light received from the object and from the paper. If the image be too bright, the paper, the tracing-point, and the outline it has made, are scarcely seen; and either less light may be allowed to come from the object, or more light (as by a taper held near) may be thrown on the paper and tracing-point. Sometimes, on the other hand, measures of the contrary kind must be taken.—Instead of the prism, some microscopists prefer a *speculum* of polished steel, of smaller size than the ordinary pupil of the eye, fixed at an angle of 45° in front of the eye-piece; and this answers exactly the same purpose as the preceding, since the rays from the eye-piece are reflected vertically upwards to the central part of the pupil placed above the mirror, whilst, as the eye also receives rays from the paper and tracer, in the same direction, through the peripheral portion of the pupil, the image formed by the microscope is visually projected downwards, as in the preceding case. This disk, the invention of the celebrated anatomist Soemmering, is preferred by some microscopic delineators to the camera lucida. The fact is, however (as the author can testify from his own experience), that there is a sort of 'knack' in the use of each instrument, which is commonly acquired by practice alone; and that a person habituated to the use of either of them, does not at first work well with another.—A different plan is preferred by some microscopists, which consists in the substitution of a *plate* of neutral-tint or darkened glass for the oblique mirror; the eye receiving at the same time the rays of the microscopic image, which are obliquely reflected to it from the surface of the glass, and those of the paper, tracing-point, &c. which come to it through the glass.—It is so extremely useful to the microscopist, to be able to take outlines with one or other of these instruments, that every one would do well to practise

the art. Although some persons at once acquire the power of seeing the image and the tracing-point with equal distinctness, the case is more frequently otherwise; and hence no one should allow himself to be baffled by the failure of his first attempt. It will sometimes happen, especially when the prism is employed, that the want of power to see the pencil is due to the faulty position of the eye, too large a part of it being over the prism itself. When once a good position has been obtained, the eye should be held there as steadily as possible, until the tracing shall have been completed. It is essential to keep in view, that the proportion between the size of the tracing and that of the object, is affected by the height of the eye above the paper; and hence that if the microscope be placed upon a support of different thickness, or the eye-piece be elevated or depressed by a slight inclination given to the body, the scale will be altered. This it is of course peculiarly important to bear in mind, when a series of tracings is being made of any set of objects which it is intended to delineate on a uniform scale; or when the camera lucida (or any similar arrangement) is employed for the purpose of *Micrometry*. All that is requisite to turn it to this account, is an accurately-divided stage-micrometer, which, being placed in the position of the object, enables the observer to see its lines projected upon the surface upon which he has drawn his outline; for if the divisions be marked upon the paper, the average of several be taken, and the paper be then divided by parallel lines at the distance thus ascertained (the spaces being subdivided by intermediate lines, if desirable), a very accurate scale is furnished, by which the dimensions of any objects drawn in outline under the same power may be minutely determined. Thus if the divisions of a stage-micrometer, the real value of each of which is 1-200th of an inch, should be projected with such a magnifying power, as to be at the distance of an inch from one another on the paper, it is obvious that an ordinary inch-scale applied to the measurement of an outline, would give its dimensions in two-hundredths of an inch, whilst each fifth of that scale would be the equivalent of a thousandth of an inch. When a sufficient magnifying power is used, and the scale thus made is minutely divided, great accuracy may be obtained. It has been by the use of this method, that Mr. Gulliver has made his admirable series of measurements of the diameters of the Blood-corpuscles of different animals.

50. *Object-Glass-Holder*.—In Microscopes of the old con-

struction, whose objectives were single lenses, these were not unfrequently mounted near the periphery of a circular disk pivotted to the lower end of the body, in such a manner that any desired power might at once be brought into use by merely rotating the disk. Since the introduction of achromatic object-glasses, this method has been until recently abandoned; every 'power' being separately connected with the extremity of the body, so as not to admit of any substitution, save by screwing-off one objective and screwing-on another. The old method, however, has been partially reverted to by Mr. C. Brooke; who has contrived a *holder* into which two objectives may be screwed, and which, being attached to the 'nose' of the body, enables either of them to be brought into position, by simply turning the arm on its pivot. This is an extremely convenient arrangement, and might easily be carried further if desired; since, by having a tri-radiate or quadri-radiate arm, three or four powers might be thus brought into use successively, with as much facility as two. The principal objection to the general use of such an appendage, lies in the nicety of workmanship that is required to obtain that exact 'centering,' which is needed to bring the axis of the objective into precise continuity with that of the body; and unless this be attained, the performance of the instrument is greatly impaired. In microscopes of the old construction, the *other* imperfections were so great, that none but an excessive deficiency in this respect would attract attention.—The convenience of such an instantaneous change in the power of the objective is very great; since it is continually desirable to obtain a general view of an object with a low power, and to examine the parts of it in detail under a higher amplification, with as little expenditure of time and trouble as possible.

51. *Object Marker*.—All Microscopists occasionally, and some continually, feel the need of a ready means of *finding*, upon a glass slide, the particular object or portion of an object, which they desire to bring into view; and various contrivances have been suggested for the purpose. Where different magnifying powers can be readily substituted one for another, as by the use of the Erector (§ 44) or of the Object-glass-holder (§ 50), no special means are required; since, when the object has been found by a low power, and brought into the centre of the field, it is rightly placed for examination by any other objective. Even this slight trouble, however, may be saved by the adoption of more special methods; among the

simplest of which is *marking* the position of the object on the surface of the thin glass which covers it. The readiest mode of doing this, when the object is large enough to be distinguished by the naked eye, is to make a small ring round it with a fine camel-hair pencil dipped in Indian-ink; but when the object is not thus visible, the slide must be laid in position on the stage, the object 'found' in the microscope, the condenser adjusted to give a bright and defined circle of light, and then, the microscope-body being withdrawn, the black ring is to be marked around the illuminated spot.—The same end, however, may be more precisely as well as more neatly accomplished, by attaching an *object-marker* to the objective itself. That of Mr. Tomes consists simply of an ivory cap, fitting over the 1/4th inch objective, having its extremity narrowed-down (like that of the objective itself) but perforated in the centre, so as to form a minute ring; the object having been 'found' and brought into the centre of the field, the cap is placed upon the objective, the ring is blackened with Indian-ink, and then, being carefully brought by the focal adjustment into contact with the surface of the glass, it stamps on this a minute circle enclosing the object.—A more elaborate contrivance of a similar kind, for marking a circle round the object by a diamond-point, attached to a cap fitting on the objective, has been recently described by Mr. Bridgman ("Quarterly Microscopical Journal," vol. iii., p. 237); this has the advantage of admitting a variation in the size of the circle, and also of substituting a delicate line for the broad ring which may partly obscure some neighbouring object; but, on the other hand, the very delicacy of the diamond-marks prevents them from being readily distinguished, and some kinds of glass are so apt to 'star' when marked with a diamond-point, that cracks or splinters may extend from the circle over the object it is intended to indicate.—The most unobjectionable and satisfactory mode of 'finding' an object, however, is, in the Author's opinion, that which is afforded by a graduation of the movable parts of the stage, in the manner to be presently described (§ 53).

52. *Lever Stage*.—The general arrangement of the Traversing Stage, now usually adapted to all high-class Microscopes, has been already explained (§§ 37—39); and though the details are differently constructed by the several makers, yet the general principle is, that a lateral or *horizontal* movement is given to the object-platform by one milled-head, and a front-to-back or *vertical* movement (the microscope being

supposed to be placed in an inclined position) by another. The stage may be so constructed, however, that motion shall be given to the object-platform by means of a *lever* acting upon it in any required direction; this being accomplished by making the object-platform slide laterally on an intermediate plate, and by making the latter slide vertically upon the fixed stage-plate which forms the basis of the whole; each pair of plates being connected by dovetailed slides and grooves. Thus the object-platform may be readily made to traverse, not merely horizontally or vertically, but, by the simultaneous sliding of both plates, in any intermediate direction. This is especially convenient in following the movements of Animalcules, &c., for which purpose this lever-stage is to be preferred to the ordinary form: its use being attended with this particular facility, that, as the motion of the hand is reversed by the lever, so that the object moves in the opposite direction, and as the motion of the object is again reversed to the eye by the microscope, the image moves in the same direction as the hand; and thus, with a little practice, even the most rapid swimmer may be kept within the field by the dexterous management of the lever. For general purposes, however, the ordinary traversing stage will be found most convenient.

53. *Object-Finder*.—Either kind of movable stage admits of a simple addition, which very much facilitates the 'finding' of minute objects mounted in slides, that are not distinguishable by the naked-eye; such, for example, as the particular forms that present themselves in Diatomaceous deposits. This 'finder' consists of two graduated scales, one of them *vertical*, attached to the fixed stage-plate, and the other *horizontal*, attached to an arm carried by the intermediate plate; the first of these scales enables the observer to 'set' the vertically-sliding plate to any determinate position in relation to the fixed plate, while the second gives him the like power of setting the horizontally-sliding plate by the intermediate. In order to make use of these scales, it is of course necessary that the sliding and rotating platform on which the object immediately rests, should be always brought into one constant position upon the traversing plates beneath; this is accomplished by means of a pair of *stops*, against which it should be brought to bear. So, again, this sliding-plate or object-platform should itself be furnished with a 'stop' for the glass slide to abut-against, so as to secure this being always laid in the same position. These stops may be made removable, so as not to interfere with the ordinary working of the stage.

Now supposing an observer to be examining a newly-mounted slide, containing any objects which he is likely to wish to find on some future occasion; he first lays the slide on the object-platform, with its lower edge resting on the ledge, and its end abutting against the lateral stop, and brings the object-platform itself into its fixed place against the stops; then if, on sweeping through the slide, he meet with any particular form worthy of note, he reads-off its position upon the two scales, and records it in any convenient mode. The scale may be divided to 50ths of an inch, and each of these spaces may be again halved by the eye; the record may perhaps be best made thus,—*Triceratium fuvus* $\frac{26}{18\frac{1}{2}}$;—the upper number always referring to the upper scale, which is the horizontal, and the lower to the vertical. Now whenever the Microscopist may wish again to bring this object under examination, he has merely to lay the slide in the same position on the platform, to bring the platform itself into its fixed place on the traversing-plate below, and then to adjust the traversing-plates themselves by their respective scales.—Even a non-movable stage may have a similar pair of scales adapted to it; the vertical scale being so placed, as to mark the position into which the object-platform is brought by sliding it up or down; and the horizontal scale being marked upon the object-platform itself, so as to allow the observer to note the precise position of the end of the glass slide. Thus let it be supposed that, by shifting the slide from side to side, and by moving the object-platform up or down, a certain object has been brought into the field; if the place of the object-platform and of the slide be then noted by the vertical and the horizontal scales, the object may be found at any future time without difficulty, by re-adjusting the slide and the object-platform to the same numbers.*—The numbers referring to each object may either

* The first of the above plans, to the utility and accuracy of which the Author can bear strong testimony, was suggested by Mr. Okeden in the "Quart. Microsc. Journal," vol. iii. p. 166. The second had been previously suggested by, Mr. E. G. Wright in the same Journal, vol. i. p. 302; the descriptions of both are made clear by figure. Other 'finders' are described and figured by Mr. J. Tyrrel, Mr. T. E. Amyot, and Mr. Bridgman, at pp. 234 and 302-304 of the last-named volume.—It appears to the Author that Mr. Okeden's plan might be adopted with very little trouble or expense in every Microscope possessed of a stage-movement, and Mr. Wright's in every Microscope with a fixed stage but movable object-carrier; and that it would be very desirable for every microscope that may be made hereafter, to be furnished with such scales. If the different makers could agree upon some common system of graduation, in the same way as Microscopists have adopted 3 inches by 1 as the standard dimension of object-slides, much trouble would

be marked upon the slides themselves, like the names of the objects, or may be recorded with these in a separate list, referring to the slides by figures alone. The general adoption of such a plan, though involving a little more labour at first, would prove in the end to be a great saving both of time and trouble.

54. *Magnetic Stage*.—If a stage be unprovided with a traversing-movement of any kind, there is no means of allowing the object to be moved in all directions with smoothness and facility, and yet of holding it in any position in which the Microscopist desires to retain it, more convenient and more ready of application, than is furnished by magnetic attraction. A magnetic stage was originally proposed by Mr. King of Bristol; but seems to have been first brought into efficient practical action by Mr. G. Busk. His plan consists in attaching two semicircular magnets to the under side of the stage, so as nearly to surround its aperture, and in inserting, for the conveyance of the magnetic force to the upper side, four soft iron pegs, which slightly project above its surface; over these an object-bearer of soft iron, with its under surface ground smooth and true, will slide so readily, as to admit of very easy and precise adjustment of the place of the object by a steady and practised hand.—Another arrangement, which has some advantages over the preceding, has been proposed by Mr. J. B. Spencer; this consists in surrounding the aperture of the stage by a ring of soft iron, the surface of which projects very slightly above the brass plate, the magnets (cut out of sheet-steel) being attached to the under side of the object-bearer. This method is perhaps more readily applicable than Mr. Busk's to the stage of *any* microscope, and will probably interfere less with its other fittings.*

55. *Diaphragm-Plate*.—No microscope-stage should ever be without a diaphragm-plate fitted to its under-surface, for the sake of restricting the amount of light reflected from the mirror, and of limiting the angle at which its rays impinge on the object (See Figs. 18 and 21). This plate should always be at least half an inch below the object, since it is otherwise comparatively inoperative; and thus, whilst it may be fixed

be saved to observers at a distance from one another, who might wish to examine each others' objects; for the numerical reference attached to each object would then enable it to be found by every observer, whose stage should be graduated upon the same method.

* For a more detailed description, with illustrative figures, of Mr. Busk's Magnetic Stage, see "Quart. Microsc. Journal." vol. ii. p. 280; and for Mr. Spencer's, vol. iii. p. 173.

immediately beneath a movable stage whose thickness serves to remove it sufficiently far, it should be fixed on the end of a short tube forming a sort of *well* on the under side of the stage, when this consists of but a single fixed plate. The diaphragm-plate should be perforated with holes of several different sizes, in the largest of which it is convenient to fit a ground-glass (this, by means of a screw-socket, may be made removable at pleasure), the use of which is to diffuse a soft and equable light over the field, when large transparent objects (such as sections of wood) are under examination; between the smallest and the largest aperture, there should be an unperforated space, to serve as a dark back-ground for opaque objects. The diaphragm-plate itself, the 'well' of the stage, in fact every part through which light passes to the object from beneath, should be blackened, in order to avoid the interference that would be occasioned by irregularly-reflected rays. The edge of the diaphragm-plate should be notched at certain intervals, and a spring-catch fitted so as to drop into the notches, in order that each aperture may be brought into its proper central position.—This simple arrangement, in combination with the mirror (which should be concave on one side and plane on the other) and side-condenser (§ 64), affords to the Microscopist all the means of illuminating his objects, whether transparent or opaque, which are ordinarily requisite: to bring out the highest powers of the instrument, however, more refined methods of illumination are required; and a far greater variety of treatment is needed in the case of many objects, the determination of whose true characters is a matter of difficulty, even under every advantage which can be derived from assistance of this kind.

56. *Achromatic Condenser*.—In almost every case in which an objective of 1-4th inch or any shorter focus is employed, its performance is greatly improved by the interposition of an achromatic combination between the mirror and the object, in such a manner that the rays reflected from the former shall be brought to a focus in the spot to which the objective is directed. This may be accomplished sufficiently well for ordinary purposes, by adapting a French triple combination of about 1-4th inch focus, to the end of a tube $1\frac{1}{2}$ inch long, which shall slide within another tube fitted to the opening in the stage, by the bayonet-catch or any similar connection that gives attachment to the diaphragm-plate. If this be correctly centred in the first instance, and the workmanship of the microscope be good, no more expensive arrangement will be

required, by such at least as may be satisfied with that degree of perfection, which suffices for the clear discernment of all but the most difficult objects. The sliding movement of the tube, especially if it be accomplished by a lever-action (as suggested by Mr. Quekett), is quite sufficient for the adjustment of the focus; and the removal of the outer lens adapts it for use with objectives below 1.4th inch, to whose performance it often affords important assistance.—In the most perfect arrangement of the Achromatic Condenser, however, such as is now adapted to all first-class instruments made in this country, the achromatic combination is one specially adapted to the purpose; and is so mounted as to ensure the greatest accuracy of its adjustments. By Mr. Ross it is supported by what he terms the 'secondary stage' (§ 37); and by Messrs. Smith and Beck it is carried upon the summit of the 'cylindrical fitting' which answers the same purpose (§ 39); whilst by Messrs. Powell and Lealand, it is attached by a bayonet-catch to the under side of the fixed stage-plate (§ 38). In either case it is provided with a pair of milled-headed screws (Fig. 36), which give it a slight degree of horizontal motion in transverse directions, for the purpose of procuring an accurate centering; and where, as in Messrs. Powell and Lealand's instrument, the focal adjustment is not given by the movement of the carriage which bears it, a rack-and-pinion is attached for this purpose to the tube of the condenser itself.—In order that the Achromatic Condenser should be made to afford the greatest possible variety of modifications of the illuminating pencil, it requires to be furnished with a diaphragm-plate (as first suggested by Mr. Gillett) immediately behind its lenses; and this should be pierced with holes of such a form and size, as to be adapted to cut-off in various degrees, not merely the peripheral, but also the central parts of the illuminating pencil. The former of these purposes is of course accomplished, by merely narrowing the aperture which limits the passage of the rays through the central part of the lens; the latter, on the other hand, requires an aperture as large as that of the lens, having its central part more or less completely occupied by a solid disk, which may so nearly fill the circle, as to leave but a mere ring through which the light may pass. Such apertures are shown in the diaphragm-plates in Figs. 35 and 36.—The Condenser thus completed is constructed on three different plans by the three principal makers, in accordance with the different arrangements of their respective stages. By Mr. Ross, who originally

carried Mr. Gillett's plans into operation, the diaphragm-plate has the shape of a short frustrum of a cone (Fig. 35), so attached to the condenser, that the portion of the plate which

FIG. 35.

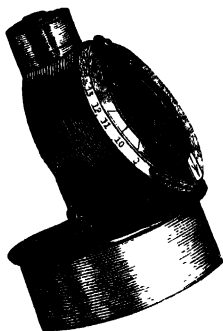

Ross's Achromatic Condenser

and Lealand, again,—their stage being too thick to allow of

FIG. 36.

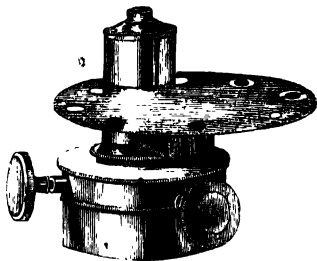

Smith and Beck's Achromatic Condenser.

passes through it shall cut it transversely; each aperture is indicated by a number on the dial; and a spring-catch is so arranged, as to mark when any one of the apertures is in its right place, and to show its number. The thinness of the stage in Messrs. Smith and Beck's microscope, allows the diaphragm-plate to be made upon the ordinary plan (Fig. 36), since it can be brought sufficiently near to the lenses of the condenser, without coming into too close contiguity with the stage; and this is obviously the simplest and most convenient arrangement. By Messrs. Powell

the diaphragm-plate being placed beneath it, without removing that plate from its proper position behind the lenses of the condenser,—the diaphragm-plate is made so small that it can be received into the interior of the stage (Fig. 37), but is rotated by a milled-head beneath; and the edge of this is marked by numbers, each signifying a particular aperture, and thus marking by its position *which* aperture

is in use. As, however, the smallness of the diaphragm-plate so limits the number of apertures, that the desirable variety could not be afforded by it alone, a second plate is made to rotate immediately beneath it upon the same axis (like the

hour and minute-hands of a watch), by means of a second milled-head, numbered at its edge like the first; and the apertures in the diaphragm-plate being simple circles, the

FIG. 37

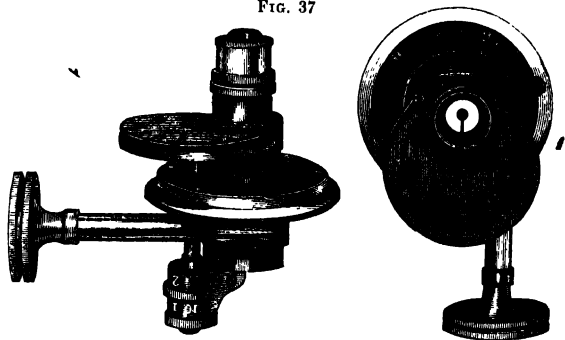

Powell and Lealand's Achromatic Condenser.

centres of these are covered by stops of different sizes, supplied by the second or 'stop'-plate; by which very ingenious arrangement, a great variety of combinations may be obtained, all of them indicated by the numbering on the two milled-heads.

57. *Reflecting Prisms*.—Every mirror composed of glass silvered at the back, gives, as is well known, a double reflection; namely, a principal image from the metallic surface, and a secondary image from the surface of the glass in front of it. This secondary image, it has been thought, interferes with the perfect performance of the achromatic condenser: and hence, for obtaining the most satisfactory definition, some Microscopists prefer to direct the axis of the microscope to the source of light (the mirror being turned aside); whilst others, feeling the inconvenience of the position thus required, have recourse to a *prism* which shall give the required reflection with only a single image. The prism usually employed (having been originally applied to this purpose by M. Dujardin) has plane surfaces, and acts, therefore, as the equivalent of a plane mirror. A reflecting prism has been devised, however, by Mr. Abraham (optician of Liverpool), which is intended by him to take the place both of mirror and achromatic condenser, though its action (as it seems to the Author) must rather be that of the ordinary concave mirror; this has one

of its surfaces hollowed-out to receive one side of a double-convex lens, the other side of which acts as the emergent surface of the prism, causing the rays as they pass through it to converge; and the prism itself being composed of flint-glass, whilst the lens is of crown, no chromatic dispersion of the rays is produced, though the spherical aberration is not corrected.

58. *White-Cloud Illuminators*.—It being universally admitted that the light of a bright white cloud is the best of all kinds of illumination for nearly every kind of Microscopic enquiry, various attempts have been made to obtain such light, from the direct rays either of the sun or of a lamp, by what may be called an artificial cloud. Some have replaced the plane mirror by a surface of pounded glass or of carbonate of soda, or (more commonly) by a disk of plaster of Paris, the latter being decidedly the preferable method; but a sufficiently bright light is not thus obtained, unless a condenser be employed to intensify the illumination of the mirror. Such a condenser may be most conveniently attached by a jointed arm to the frame which carries the disk, according to the method of Messrs. Powell and Lealand, shown in Fig. 38;

FIG. 38.

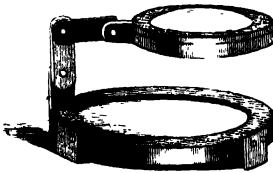

White-Cloud Illuminator.

the frame itself being made to fit upon the mirror, and to turn with it in every direction. — Another very simple, and for many purposes very efficient mode of obtaining a white-cloud illumination (invented by Mr. Handford) consists in coating the back of a concave plate of glass, like that employed in the ordinary con-

cave mirror, with white zinc paint, instead of silvering it; and then mounting this in a frame, which may be fitted (like the plaster-of-Paris disk just described) over the ordinary mirror. A concave surface of plaster-of-Paris, moreover, might easily be obtained, by casting it when fluid upon the convex surface of such a plate. When a concavity is thus given to the white surface, its performance with low powers is much improved; but with high powers, a special condensation of the light must be adopted, and the arrangement above described seems the simplest that could be devised. It is open, however, to certain objections, which

become apparent when very high powers are used and difficult objects are under examination; and to obtain the most perfect white-cloud illumination possible, is the object of the apparatus devised by Mr. Gillett. This consists of a small camphine lamp, placed nearly in the focus of a parabolic speculum, which reflects the rays either at once upon a disk of roughened enamel, or upon a second (hyperbolic) speculum which reflects them upon such a disk. A very pure and concentrated light is thus obtained; and as the forms of the incident pencils are broken-up by the roughened surface, that surface takes the place of the lamp, as the source from which the rays primarily issue. The advantage of this illumination is specially felt, in the examination of objects of the most difficult class under the highest powers.

59. *Oblique Illuminators*.—It is frequently desirable to obtain a means of illuminating transparent objects with rays of more obliquity than can be reflected to them from the mirror, even when this is thrown as much as its mounting will permit out of the axis of the Microscope (§ 39), or than can be transmitted by the ordinary achromatic condenser, even when all but its marginal aperture is stopped-out. Such oblique light may be used in two entirely different modes. The rays, although very far out of the axis of the microscope, may still not make too great an angle with it to fall beyond the aperture of the objective; and thus, entering its peripheral portion after their passage through the object, they will form the image in the ordinary way. The advantage of such oblique illumination, arises from its power of bringing-out markings which cannot be seen when only direct rays are employed; and when the rays come only from one side, so as to throw a strong shadow, and either the stage or the illuminator is made to rotate, so that the light shall fall upon the object *successively* in every azimuth, information may often be gained respecting the nature of these markings, which can be acquired in no other mode.—But the direction given to the rays may be so oblique, that they shall not enter the object-glass at all; in this case, they serve to illuminate the object itself, which shines by the light whose passage it has interrupted; and as the observer then receives no other light than that which radiates from *it*, the object (provided it be of a nature to stop enough light) is seen *bright* upon a *dark field*.—Each of these methods has its advantages for particular classes of objects; and it is advisable, in all doubtful cases, to have recourse to every variety of oblique illumination that

shall present the object under a different aspect. Almost every Microscopist who has especially devoted his attention to the more difficult *lined* or *dotted* objects, has devised his own particular arrangement for oblique illumination, and feels confident of its superiority to others. To give a full description of all, would be quite unsuitable to our present object; those, therefore, will be specially noticed, which have already acquired *general* approval; whilst such as have only been recommended by *individuals*, will be simply referred to. As they have little in common, save their purpose, it seems scarcely possible to classify them according to any other character, than that afforded by the *direction* which they give to the oblique rays; some of them bringing these to bear on the object from *one side* alone, and others from *all sides*.

60. One of the earliest methods devised for obtaining oblique light, was the *excentric prism* of M. Nacet; which, occupying the place of the achromatic condenser, and like it receiving its light from the mirror, has its surfaces so arranged, as to throw a converging pencil of rays on the under side of the object, whose axis is at an angle of about 40° with the axis of the microscope. One great convenience of this instrument lies in the power of giving revolution to the prism, by simply turning it in its socket, so as to direct the oblique rays upon the object from every side successively, without moving the stage. Its principal disadvantages consist in the limitation of its aperture (producing a deficiency of light), in the want of correction for its chromatic aberration, and in the absence of any power of varying the obliquity of the illuminating pencil*—All these disadvantages seem to be remedied by the plan of oblique illumination recently proposed by Mr. Sollitt of Hull, which consists in the employment of an Achromatic condenser of very long focus and large aperture, mounted in such a manner as to enable its axis to be inclined to that of the microscope through a wide angular range; a condenser of this description he states to be suitable also for all ordinary purposes. ("Quart. Microsc. Journ.," vol. iii p 87) Such an instrument, when its axis does not form a very large angle with that of the microscope, may receive its light from the plane mirror, especially if this be so mounted as to be capable of being turned considerably out of the visual axis; but when its position is too oblique for

* A full description of M. Nacet's prism, and a mathematical investigation of its properties, by Mr. G. Shadbolt, will be found in the "Transactions of the Microscopical Society" (1st Series), vol. iii. p 71, *et seq.*

the light to be thus supplied to it, recourse must be had to rays either proceeding direct from their source (such as a lamp or a bright cloud), or directed at the requisite angle by a reflector placed in a suitable position. For this latter purpose, a rectangular prism (§ 57), mounted on a separate stand, will be found very convenient.—By many observers, a combination of the *reflecting* and *refracting* powers of a prism is preferred, which causes the rays to be at once reflected by a plane surface, and concentrated by lenticular surfaces; so that the prism answers the purpose of mirror and condenser at the same time. Such a prism was first constructed by Amici; and it may be either mounted on a separate base, or attached to some part of the microscope-stand. The mounting adopted by Messrs Smith and Beck, and shown in Fig. 39, is a very simple and convenient one; this consists in attaching the frame of the prism to a sliding bar, which works in dovetail grooves on the top of a cap that may be set on the cylindrical fitting beneath the stage; the slide serves for the regulation of the distance of the prism from the axis of the microscope, and consequently of the obliquity of the illumination; whilst its distance beneath the stage is adjusted by the rack-movement of the cylindrical fitting. In this manner, an illuminating pencil of almost any degree of obliquity may be readily obtained; but there is no provision for the correction of its aberrations. Such a provision is afforded by the achromatic prism of Mr. Abraham (§ 57), which may be mounted in the manner just described. And the same object is attained by an arrangement devised by Mr. Grubb, a Dublin optician, of which Dr. Robinson of Armagh speaks very highly; the prism having its aberrations corrected for a lamp placed at a given distance in the plane of the stage; and being mounted in such a manner as to be capable of travelling (like Mr. Sollitt's condenser) through an angular range of as much as 120° (“Quart. Microsc. Journ.,” vol. iii. p. 166).—In all of these methods, the obliquity of the illumination is practically

FIG. 39.

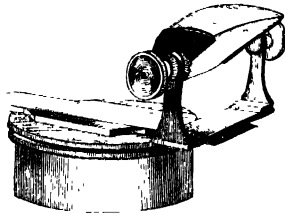

Amici's Prism for oblique illumination

practically

limited by the construction of the stage, and especially by the relation which its thickness bears to the diameter of its lower aperture. The thinner the stage, and the larger its lower aperture, the more oblique will be the rays which *may* be transmitted through it; and in admitting an extreme obliquity of illumination, the thin stage recently introduced into some of the best Microscopes (§§ 38, 39) possesses a great advantage over all whose thickness is greater. On the other hand, it is when the rays are most oblique, that the greatest advantage is gained by making them fall upon the object from every side in succession; and where this cannot be accomplished (as in the case of Næchet's prism) by the rotation of the illuminating apparatus, the rotatory movement must be given to the object. It is obvious that, for this purpose, a revolving stage which keeps the object constantly in the field (§ 37), is decidedly preferable to one which does not possess such a movement; but the means have not yet been found of obtaining this advantage without some sacrifice of the other.

61. Whenever the rays are directed with such obliquity, as not to be received into the object-glass at all, but are sufficiently retained by the object, to render it (so to speak) self-luminous, we have what is known as the *black-ground illumination*: to which the attention of Microscopists generally was first drawn by the Rev J. B. Reade, in the year 1838, although it had been practised some time before, not only by the Author but by several other observers. For low powers whose angular aperture is small, and for such objects as do not require any more special provision, a sufficiently good 'black-ground' illumination may be obtained by means of the concave mirror alone, especially when it is so mounted as to be capable of a more than ordinary degree of obliquity. In this manner it is often possible, not merely to bring into view features of structure that might not otherwise be distinguishable, but to see bodies of extreme transparency (such, for instance, as very minute Animalcules) that are not visible when the field is flooded (so to speak) by direct light, these presenting the beautiful spectacle of phosphorescent points rapidly sailing through a dark ocean. Where the mirror cannot be placed in a position oblique enough to give this effect, a black-ground illumination sufficiently good for many purposes may be obtained by Mr. Reade's original method; which consisted in dispensing with the mirror altogether, and in placing the lamp and ordinary condensing-lens (§ 61) in such a position beneath and to one

side of the stage, as to throw upon the under side of the object a pencil of rays too oblique to enter the object-glass after passing through it.—Another very simple mode, which answers sufficiently well for low powers and for the larger objects which these are fitted to view, consists in the substitution, for the achromatic condenser, of a plano convex lens of great convexity, forming a large segment of its sphere, with a central stop to cut off the direct rays; for the rays passing through the marginal portion of this *Spotted Lens*, being strongly refracted by its high curvature, are made to converge at an angle too wide for their entrance into an objective of moderate aperture, and thus the field is left dark; whilst all the light stopped by the object serves (as it were) to give it a luminosity of its own.—Neither of the foregoing plans, however, will answer well for objectives of high power, having such large angles of aperture that the light must fall *very* obliquely to pass beyond them altogether. Thus if the pencil formed by the ‘spotted lens’ have an angle of 60° , its rays will enter a 1.4th inch objective of 70° , and the field will not be darkened. For obtaining a greater degree of obliquity, Mr. Wenham has contrived a *Parabolic Speculum*,* having its apex cut off, so that the object might be placed in the focus, to which all rays parallel to its axis are reflected; and the direct rays being checked by a stop placed behind it, the object is illuminated only by those which are reflected to it from all sides of the interior of the parabola at a very oblique angle. As the thickness of the glass-slide on which the object is mounted, was found by Mr. W. to produce a very sensible aberration in the rays converging towards it, he interposed a meniscus lens, having such a curvature as to produce a counteracting aberration of an opposite kind. The circular opening at the bottom of the wide tube (Fig. 40) that carries the speculum, may be fitted with a diaphragm adapted to cover any portion of it that may be desired; and by giving rotation to this diaphragm, rays of great obliquity may be made to fall upon the object from every azimuth in succession (§ 60) —A like purpose was aimed-at in the *Annular Condenser* of Mr. Shadbolt,† which consists of a ring of glass whose surface was so shaped as to present a prismatic section; the inclination of the outer side being such as to produce a total reflection of the rays impinging on it, and to direct these through the inner side of the ring, so as to

* “Transactions of the Microscopical Society” (1st Series), vol. iii. p. 85.

† *Op. cit.*, p. 132.

fall at a very oblique angle upon the object, from every azimuth of the circle.—A combination of both methods is adopted in the *Parabolic Illuminator* (Fig. 40) now supplied by Messrs. Smith and Beck; for this consists of a paraboloid

Fig. 40.

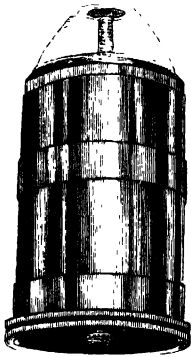

Parabolic Illuminator.

of glass, resembling a cast of the interior of Mr. Wenham's parabolic speculum, but reflecting the rays which fall upon the outer surface of the glass, like Mr. Shadbolt's annular prism. It has the advantage of being more easily constructed than the parabolic speculum, and is little if at all inferior to it in performance; but it requires that an appropriate 'stop' should be adapted to it, for each objective with which it is to be used: whilst in Mr. Wenham's speculum, the requisite adaptation for the angular aperture of the objective is made by altering the position of the stop by means of the central stem; the effect of which alteration is to cut-off a larger and larger proportion of the least-oblique rays, the more nearly the stop is approximated

to the object; and thus to illuminate it more and more exclusively by those which meet at the widest angle.—In using either of these illuminators, the rays which are made to fall upon them should be parallel, consequently the *plane* mirror should always be employed; and when, instead of the parallel rays of daylight, we are obliged to use the diverging rays of a lamp, these should be rendered as parallel as possible, previously to their reflection from the mirror, by the interposition of the 'bull's-eye' condenser (§ 64) so adjusted as to produce this effect.

62. For the exhibition of those classes of objects which are suitable for 'black-ground' illumination, and which are better seen by light sent into them from every azimuth, than they are by a pencil, however bright, incident in one direction only, no more simple, convenient, and efficient means could probably be found, than that which is afforded by the 'spotted lens' for low powers, and by the 'parabolic illuminator' for powers as high as 1-4th or 1-5th of an inch focus;—the use of the latter with the highest powers, being rendered

disadvantageous by the great reduction in the amount of light, occasioned by the necessity for cutting-off of all the rays reflected from the paraboloid, which fall upon the object within the limits of their angle of aperture.—One of the great advantages of this kind of illumination consists in this; that, as the light *radiates from* each part of the object as its proper source, instead of merely *passing through* it from a more remote source, its different parts are seen much more in their normal relations to one another, and it acquires far more of the aspect of solidity. The rationale of this is easily made apparent, by holding-up a glass vessel with a figured surface between one eye and a lamp or a window, so that it is seen by transmitted light alone; for the figures of its two surfaces are then so blended-together to the eye, that unless their form and distribution be previously known, it can scarcely be said with certainty which markings belong to either. If, on the other hand, an opaque body be so placed behind the vessel, that no rays are transmitted directly through it, whilst it receives adequate illumination from the circumambient light, its form is clearly discerned, and the two surfaces are differentiated without the least difficulty.

63. *Polarizing Apparatus.*—In order to examine transparent objects by polarized light, it is necessary to employ some means of *polarizing* the rays before they pass through the object, and to apply to them, in some part of their course between the object and the eye, an *analyzing* medium. These two requirements may be provided-for in different modes. The *polarizer* may be either a bundle of plates of thin glass, used in place of the mirror, and polarizing the rays by reflection; or it may be a ‘single-image’ or ‘Nicol’ prism of Iceland Spar, which is so constructed as to transmit only one of the two rays into which a beam of ordinary light is made to divaricate on passing through this substance; or it may be a plate of Tourmaline, or one of the artificial tourmalines composed of the disulphate of iodine and quinine, now known by the designation of ‘Herapathite’ after the name of their discoverer. Of these methods, the ‘Nicol’ prism is the one generally preferred; the objection to the reflecting polarizer being, that it cannot be made to rotate the tourmaline being undesirable, on account of the colour which it imparts when sufficiently thick to produce an effective polarization; and the crystals of Herapathite being seldom obtained perfect, of sufficient size to afford a good illumination. The polarizing prism is usually fitted into a

tube (Fig. 41, A, *a*) with a large milled-head (*c*) at the bottom, by which it is made to rotate in a collar (*b*) that is attached

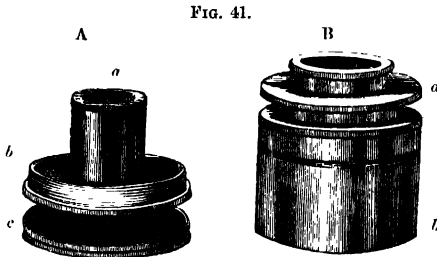

Fitting of Polarizing Prism in Smith and Beck's Microscope.

to the microscope; this collar may be fitted to the under side of the stage-plate, or, where a secondary stage is provided, it may be attached to this; in the microscope of Messrs. Smith and Beck, it screws into the lower part (*b*) of a tube (Fig. 41, B) that slides into the 'cylindrical fitting' beneath the stage (Fig. 29). The *analyzer*, which may be either a 'Nicol' prism, a Tourmaline, or a crystal of Herapathite, is usually placed either in the interior of the microscope, or between the eye-piece and the eye. If it be a prism, it is mounted in a tube, which may either be screwed into the lower end of the body in the situation of the erector (Fig. 32), or may be fitted over the eye-piece in place of its ordinary cap (Fig. 42); in the former situation it has the advantage of not

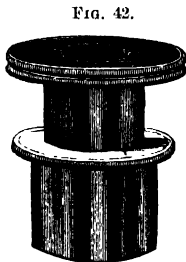

Fitting of Analyzing Prism
upon the Eye-piece

limiting the field, but it stops a considerable proportion of the light; in the latter, it detracts much less from the brightness of the image, but cuts off a good deal of the margin of the field. A plate of Tourmaline or Herapathite, if obtainable of sufficient size and freedom from colour, has a decided advantage above the Nicol prism, as an analyzer, in being free from both these inconveniences; and it may be set in a cap which fits over the ordinary cap of the eye-piece.—For bringing-out certain effects of colour

by the use of Polarized light (Chap. xx.), it is desirable to interpose a plate of Selenite beneath the polarizer and the object; and it is advantageous that this should be made to revolve. A very convenient mode of effecting this, is to mount the selenite plate in a revolving collar, which fits into the upper end (*a*) of the tube (Fig. 41, *b*) that receives the polarizing prism. In order to obtain the greatest variety of coloration with different objects, films of selenite of different thicknesses should be employed; and this may be accomplished by substituting one for another in the revolving collar. A still greater variety may be obtained by mounting three films, which separately give three different colours, in a frame resembling that in which hand-magnifiers are usually mounted, so that they may be used singly or in double or triple combinations; as many as thirteen different tints may thus be obtained; but the advantage of revolution is sacrificed—When the construction of the microscope does not readily admit of the connection of the selenite plate with the polarizing prism, it is convenient to make use of a plate of brass (Fig. 43) somewhat larger than

FIG. 43.

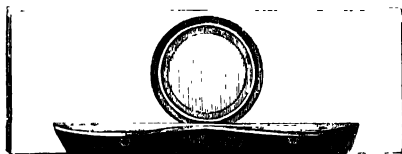

Selenite Object-carrier.

the glass slides in which objects are ordinarily mounted, with a ledge near one edge for the slide to rest-against, and a large circular aperture into which a glass is fitted, having a film of selenite cemented to it; this 'selenite stage' or object-carrier being laid upon the stage of the microscope, and the slide containing the object being placed upon it, the effect of the selenite is obtained, as in the previous arrangement; and by an ingenious modification contrived by Dr. Leeson, the ring into which the selenite plate is fitted being made movable, one plate may be substituted for another, whilst rotation may be given to the ring by means of a tangent-screw fitted into the brass-plate. Such a 'selenite stage' answers every pur-

pose that can be required; but as there is no provision for using two or three plates in combination, it is necessary to have a distinct selenite-plate for every modification of colours that may be desired.—A very beautiful effect may be obtained with certain kinds of semi-opaque objects, by illuminating them by means of a ‘spotted lens’ (§ 61), with a polarizer of Herapathite placed at such a distance above it as to receive the converging hollow pencil near its termination in the object, and an analyzer of the usual description,—a combination devised by Mr. Furze,* for the solidity which this mode of oblique illumination imparts to certain objects, is remarkably heightened by the play of colours afforded by the polarization of the light.—When the polarizing apparatus is being employed with any but the lowest powers, it is very advantageous to use the achromatic condenser in combination with it; this combination, which cannot be made in ordinary microscopes, is provided for in that of Messrs. Smith and Beck, by the ‘cylindrical fitting’ so often referred to, which can receive the polarizing prism at its lower end, and the achromatic condenser at its upper, whilst the selenite plate or plates may be interposed between them.†

61. *Illuminators for Opaque Objects.*—All objects through which sufficient light cannot be *transmitted* to enable them to be viewed in the modes already described, require to be illuminated by rays, which, being thrown *upon* the surface under examination, shall be *reflected* from it into the microscope; and this mode of viewing them may often be advantageously adopted in regard to semi-transparent or even transparent objects, for the sake of the diverse aspects it affords.—Among the various methods devised for this purpose, the one most generally adopted consists in the use of a *condensing lens*, either attached to the microscope, or mounted upon a separate stand, by which the rays proceeding from a lamp or from a bright sky are made to converge upon the object. For the efficient illumination of large opaque objects, such as injected preparations, it is desirable to employ a ‘bull’s-eye’ condenser (which is a plano-convex lens of short focus, two or three inches in diameter), mounted upon a separate stand, in such a manner as to allow of being placed in a great variety of

* ‘Transactions of the Microscopical Society’ (2nd Series), vol. iii. p. 63.

† For an account of the nature and properties of Polarized Light, which would be out of place in the present treatise, see the chapters on that subject in Dr. Golding Bird’s “Manual of Natural Philosophy,” Dr. Pereira’s “Lectures on Polarized Light,” New Ed., edited by Prof. Baden Powell, or any modern treatise on Optics.

positions. The mounting shown in Fig. 44 is perhaps one of the best that can be adopted: the frame which carries the lens is borne at the bottom upon a swivel-joint, which allows it to be turned in any azimuth; whilst it may be inclined at any angle to the horizon, by the revolution of the horizontal tube to which it is attached, around the other horizontal tube which projects from the stem; by the sliding of one of these tubes within the other, again, the horizontal arm may be lengthened or shortened, the lens may be secured in any position (as its weight is apt to drag it down when it is inclined, unless the tubes be made to work, the one into the other, more stiffly than is convenient) by means of a tightening collar milled at its edges; and finally the horizontal arm is attached to a spring socket, which slides up and down upon a vertical stem. The optical effect of such a lens differs according to the side of it turned towards the light, and the condition of the rays which fall upon it. The position of *least* spherical aberration, is when its *convex* side is turned towards *parallel* or towards the *least diverging* rays; consequently,

FIG. 44.

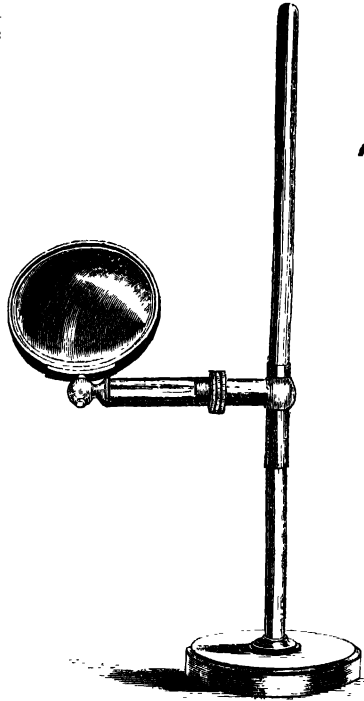

Bull's-Eye Condenser.

at its edges; and finally the horizontal arm is attached to a spring socket, which slides up and down upon a vertical stem. The optical effect of such a lens differs according to the side of it turned towards the light, and the condition of the rays which fall upon it. The position of *least* spherical aberration, is when its *convex* side is turned towards *parallel* or towards the *least diverging* rays; consequently,

when used by daylight, its *plane* side should be turned towards the *object*; and the same position should be given to it, when it is used for procuring converging rays from a lamp, the lamp being placed four or five times farther off on one side, than the object is on the other. But it may also be employed for the purpose of reducing the diverging rays of the lamp to parallelism, for use either with the parabolic illuminator (§ 61), or with the side-reflector to be presently described; and the *plane* side is then to be turned towards the lamp, which must be placed at such a distance from the condenser, that the rays which have passed through the latter shall form a luminous circle equal to it in size, at whatever distance from the lens the screen may be held.—Even where the large ‘bull’s-eye’ condenser is provided, it is well to have a smaller condensing lens in addition; and this, which is

FIG. 15.

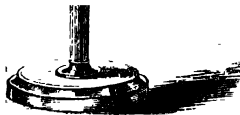
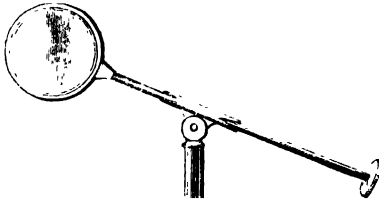

Ordinary Condensing Lens.

usually a double-convex lens, may either be mounted on a separate base (Fig. 15), or may be attached to some part of the microscope-stand. (In Messrs. Smith and Beck's large microscope, Fig. 29, two sockets with binding-screws, one for the condensing lens, the other for the side-reflector, are seen in the ‘lumb’). This condensing lens is sufficient by itself for most ordinary purposes; and it may also be used to obtain a greater concentration of the rays

already brought into convergence by the bull’s-eye (§ 93).
65. The illumination of opaque objects may be effected by *reflection*, as well as by *refraction*; and a very advantageous

means of using the light of a lamp for this purpose, is afforded by the *Side-Reflector* contrived by Mr. Ross. This is a highly-polished concave speculum (Fig. 46), which can be placed above and to one side of the object; and which is so mounted as to be capable of being placed in every kind of position, according to the place of the lamp, and the degree of obliquity of the illumination required. The squared stem, with which the speculum is connected by several intermediate joints, may be fitted to a socket, either in the stage or in some part of the microscope-stand, like that of the smaller condensing lens. The light reflected by the speculum upon the object, may be either that which falls on it direct from the lamp, or may come to it through the intervention of the bull's-eye, arranged so as to throw parallel rays upon the speculum (§ 64).—The prisms already described as in use for the illumination of transparent objects by the reflection of light from beneath, may also be employed, by an inversion of their position, for the illumination of opaque objects from above. In Continental Microscopes, the prism is frequently attached to the lower end of the body; but this is an undesirable mode of supporting it, since the illumination is disturbed by every alteration in the distance between the body and the object. This seems to be provided against by the mounting of the prism in Mr. Grubb's microscope (§ 60), which allows it to be used at any angle either above or below the stage.—A mode of illuminating opaque objects by a small concave speculum reflecting the

FIG. 46.

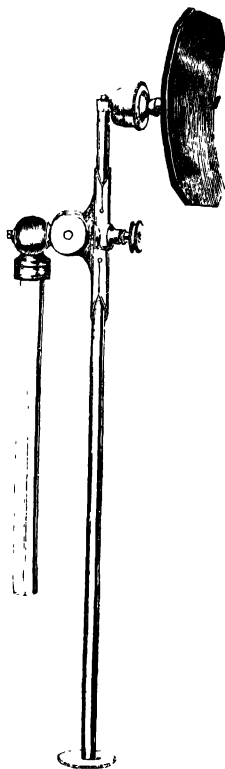

Side-Reflector.

light directly down upon it, was formerly much in use, but is now comparatively seldom employed. This concave speculum, termed a 'Lieberkuhn' from the celebrated Microscopist who invented it, is made to fit upon the end of the objective, having a perforation in the centre for the passage of the rays from the object to the lens; and it receives its light from the mirror beneath, the object being so mounted as only to stop out the central portion of the rays that are reflected upwards. The curvature of the speculum is so adapted to the focus of the object-glass, that, when the latter is duly adjusted, the rays reflected up to it from the mirror shall be made to converge strongly upon the part of the object that is in focus; consequently unless (as is sometimes done) the speculum should be mounted on a tube sliding over the 'nose' of the microscope, and capable of being adjusted to the different distances required by the several objectives, a separate speculum is required for every object-glass. The disadvantages of this mode of illumination are chiefly these;—first, that by sending the light down upon the object almost perpendicularly, there is scarcely any shadow, so that the inequalities of its surface, and any minute markings which it may present, are but faintly or not at all seen; second, that the size of the object must be so limited by that of the speculum, as to allow the rays to pass to its marginal portion; and third, that a special mode of mounting is required, to allow the light to be reflected from the mirror around the margin of the object. The first objection may be in some degree removed, by turning the mirror considerably out of the axis, so as to reflect its light obliquely upon the Lieberkuhn, which will then send it down obliquely upon the object; the illumination, however, will not even then be so good as that which is afforded by the side-reflector. The mounting of opaque objects in wooden slides (Chap. v.), which affords in many cases the most convenient means of preserving them, completely prevents the employment of the Lieberkuhn in the examination of them; and they must either be set, for this purpose, upon disks which afford them no protection, or in glass cells with a blackened back-ground. The cases wherein the Lieberkuhn is most useful, are those in which it is desired to examine small opaque objects, such as can be held in the stage-forceps (§ 66), or laid upon a slip of glass, with lenses of half-inch focus or less; since a stronger light can be thus concentrated upon them, than can be easily obtained by side-illumination. In every such case, a black back-ground must be provided, of

such a size as to fill the field, so that no light shall come to the eye direct from the mirror, and yet not large enough to create any unnecessary obstruction to the passage of the rays from the mirror to the speculum. With each Lieberkuhn is commonly provided a blackened stop of appropriate size, having a well-like cavity, and mounted upon a pin which fits into a support connected with the under side of the stage; but though the 'dark well' serves to throw-out a few objects with peculiar force, yet, for all ordinary purposes, a spot made with black paper or black sealing-wax-varnish upon a slip of glass will answer the required purpose very effectually, the slip being simply laid upon the stage beneath the object. •

Section 2. *Apparatus for the Presentation of Objects.*

66. *Stage-Forceps*.—Every Microscope should be furnished with a pair of Stage-forceps (Fig. 47) for holding minute

FIG. 47.

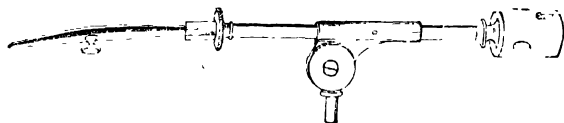

Stage-Forceps.

objects beneath the object-glass. They are mounted by means of a joint upon a pin, which fits into a hole either in the corner of the stage itself or in the object-platform; the object is inserted by pressing the pin that projects from one of the blades, whereby it is separated from the other; and the blades close again, so as to retain the object when the pressure is withdrawn. By sliding the wire-stem which bears the forceps through its socket, and by moving that socket vertically upon its joint, and the joint horizontally upon the pin, the object may be brought into the field precisely in the position required; and it may be turned round and round, so that all sides of it may be examined, by simply giving a twisting movement to the wire stem. The other extremity of the stem often bears a small brass box filled with cork, and perforated with holes in its side; this affords a secure hold to common pins, to which disks of card, &c., may be attached, whereon objects are mounted for being viewed with the Lieberkuhn. This method of mounting was formerly much in vogue, but has

been less employed of late, since the Lieberkuhn has fallen into comparative disuse

67. *Glass Stage-Plate*.—Every Microscope should be furnished with a piece of plate-glass, about 4 in by $1\frac{1}{2}$ in., to one margin of which a narrow strip of glass is cemented, so as to form a ledge. This is extremely useful, both for laying objects upon (the ledge preventing them from sliding-down when the microscope is inclined), and for preserving the stage from injury by the spilling of sea-water or other saline or corrosive liquids, when such are in use. Such a plate not only serves for the examination of transparent, but also of opaque objects; the dark back-ground being furnished by the diaphragm-plate (§ 55), and the condensing-lens being so placed as to throw a side-light upon them.—A small addition may be conveniently made to the glass stage-plate, which adapts it for use as a *Growing-Slide*. A circular aperture, of about the diameter of a test-tube, is made near one end of the plate (the length of which, for this purpose, had better be not less than 5 inches), and in this is to be fitted a little cup, formed of the end of a test-tube, about three quarters of an inch deep, in such a manner that its rim shall project a little above the surface of the plate. The cup may be closed by an ordinary cork, or (to avoid danger of splitting it) by a disk of glass cemented to a ring of cork which shall embrace the exterior of the tube; but a small aperture must be left, by grinding a notch in the rim of the cup, sufficient to admit the passage of two or three threads of lamp-cotton. The manner in which the ‘growing-slide’ is used, is this.—Supposing we wish to follow the changes undergone by some minute Alga or Infusorium, which we have just detected in a drop of liquid under examination upon an ordinary slip of glass (and covered with thin glass),—we transfer this slip to the ‘growing-slide,’ fill the cup with distilled water mixed with a small proportion of the water in which the organism was found, and then so arrange the threads (previously moistened with distilled water), that they shall pass from the cup to the edge of the liquid in which the object is contained. Thus, as the water evaporates from beneath the thin glass, the threads will afford a continuous supply, and the threads will not become dry, until the whole of the liquid has been absorbed by them and has been dissipated by evaporation. Fresh supplies may, of course, be introduced into the cup from time to time, as may be needed, so as to prevent any loss of liquid from beneath the thin glass; and in this manner, the most important requisite for

the continued growth of aquatic organisms,—a constant supply of liquid, without an exclusion of air,—may be secured.*

68. *Aquatic Box or Animalcule Cage.*—This, also, is an appendage with which every Microscope should be provided, so varied and so constant is its utility. It consists of a short piece of wide brass tube, fixed perpendicularly at one end into a flat plate of brass (Fig. 48) which is itself perforated by an aperture equal

in diameter to that of the tube, and having its opposite extremity closed by a disk of glass (B, *b*); over this fits a cover, formed of a piece of tube just large enough to slide rather stiffly upon that which forms the box, closed at the top by another disc of glass (B, *a*). The cover being taken-off, a drop of the liquid to be examined, or any thin object which can be most advantageously looked-at in

fluid, is placed upon the lower plate, the cover is then slipped over it, and is pressed-down until the drop of liquid be spread-out, or the object be flattened, to the degree most convenient for observation. If the glass disk which forms the lid be cemented or burnished into the brass ring which carries it, a small hole should be left for the escape of air or superfluous fluid; and this hole may be closed-up with a morsel of wax, if it be desired to prevent the included fluid from evaporating. But as it is desirable that this glass should be thin enough to allow a 1-11th inch objective to be employed for the examination of Animalcules, &c., and as such thin glass is extremely apt to be broken, it is a much better plan to furnish the brass cover with a screw-cap, which holds the glass disk with suffi-

FIG. 48.

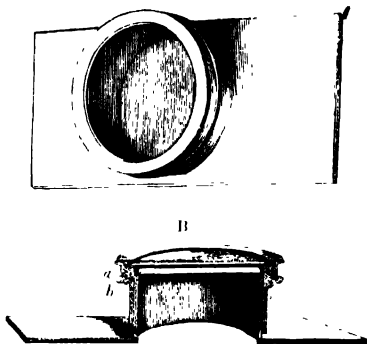

Aquatic Box or Animalcule-Cage, as seen in perspective at A, and in section at B.

* See the "Micrographic Dictionary," by Dr. Griffith and Mr. Henfrey Introduction, p. xx.

cient firmness, but permits it to be readily replaced when broken; and as the looseness of this fitting gives ample space for the escape of air or fluid around the margin of the disk, no special aperture is needed. It is always desirable, if possible, to prevent the liquid from spreading to the edge of the disk; since any objects it may contain are very apt, in such a case, to be lost under the opaque ring of the cover; this is to be avoided by limiting the quantity of liquid introduced, by laying it upon the centre of the lower plate, and by pressing-down the cover with great caution, so as to flatten the drop equally on all sides, stopping short when it is spreading too close to the margin. With a little practice, this object may in general be successfully attained; but if so much superfluous liquid should have been introduced, that it has flooded the circumference of the inclosed space, and exuded around the edge of the disk, it is better to wipe the whole perfectly dry, and then to introduce a fresh drop, taking more care to limit its quantity and to restrain it within convenient bounds. If the box be well-constructed, and the glass disks be flat, they will come into such close contact, that objects of extreme thinness may be compressed between them; hence not only may such small animals as Water-fleas (*Eutomostraca*) be restrained from the active movements which preclude any careful observation of their structure,—and this without any permanent injury being inflicted upon them,—but much smaller creatures, such as Wheel-Animalcules (*Rotifera*), or *Bryozoa*, may be flattened-out, so as to display their internal organization more clearly, and even the larger *Infusoria* may be treated in like manner. The working Microscopist will find it of great advantage to possess several of these aquatic boxes, of different sizes; and one or two of them may have the glass cover of stronger glass than the rest, and firmly fixed in its rim, so that, if the cover be made to slide equably on the box, the instrument (in hands accustomed to careful manipulation) may be made to answer the purpose of a *compressorium* (§ 70).

69. *Zoophyte-Trough*.—For the examination of living aquatic objects, too large to be conveniently received into the Aquatic Box, the *Zoophyte-trough* contrived by Mr Lister may be employed with great advantage. This consists of a trough of the shape represented in Fig. 48, formed of plates and slips of plate-glass cemented together by marine glue; of a loose vertical plate of glass, just so much smaller than the front or back of the inside of the trough, as to be

able to move freely between its sides; and of a horizontal slip of glass, whose length equals that of the inside-bottom of the trough, but whose breadth is inferior by the thickness of the plate just mentioned. The trough being filled with water (fresh or salt as the case may be), the horizontal slip is laid at the bottom, and the vertical plate is placed in contact with the front of the trough, its lower margin being received into the space left at the

FIG. 19.

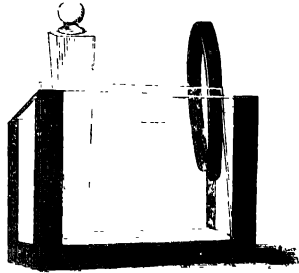

Zoophyte-Trough

front edge of the horizontal slip, which serves to hold it there, acting as a kind of hinge; a small ivory wedge is then inserted between the *front-glass* of the trough and the upper part of the vertical plate, which it serves to press backwards; but this pressure is kept in check by a little spring of bent whalebone, which is placed between the vertical plate and the *back-glass* of the trough. By moving the ivory wedge up or down, the amount of space left between the upper part of the vertical plate and the front-glass of the trough, can be precisely regulated; and as their lower margins are always in close apposition, it is evident that the one will incline to the other, with a constant diminution of the distance between them, from above downwards. Hence a Zoophyte, or any similar body, dropped into this space, will descend until it rests against the two surfaces of glass, and will remain there in a situation extremely convenient for observation; and the regulating-wedge, by increasing or diminishing the space, serves to determine the level to which the object shall fall — Of these troughs, again, it is convenient for the working Microscopist to be furnished with several, of different sizes; and in one of them *Chara* or *Nitella* may be kept growing, in a state very convenient for observation. A similar trough may be provided for this last purpose, however, by dispensing with the vertical plate and horizontal slip altogether, and approximating the front and back-plates so

that only a very narrow space is contained between them; in this case it is convenient to let the upper lip of the back-plate project considerably beyond that of the front plate, as objects may then be much more readily inserted between them; and the back plate may also be conveniently made to project beyond the sides of the trough, as would be useful, too, in the case of larger troughs. If it be wished to grow Chara, &c. in a thin trough of this kind, the trough, whenever it is not under observation, should be immersed in a tumbler or jar of water; since the plant will not flourish in a very limited supply.

70. *Compressorium*.—The purpose of this instrument is to apply a graduated pressure to objects, whose structure can only be made-out when they are thinned by extension. For such as will bear tolerably rough treatment, a well constructed Aquatic Box may be made to answer the purpose of a compressor; but there is a very large class, whose organization is so delicate as to be confused or altogether destroyed by the slightest excess of pressure; and for the examination of such, an instrument in which the degree of compression can be regulated with precision, is almost indispensable. Various plans of construction have been proposed; but none among them appears to the Author to present so many advantages as the one represented in Fig. 50, the general plan of which was originally devised by Schiek of Berlm, but the details of which have been modified by M. de Quatrefages, who has constantly employed this instrument in his elaborate and most successful researches on the organization of the Marine Worms. It consists of a plate of brass between 3

FIG. 50.

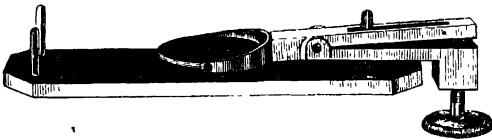

Compressorium

and 4 inches long, and from $1\frac{1}{4}$ to $1\frac{1}{2}$ inch broad, having a central aperture of from $\frac{1}{2}$ to $\frac{3}{4}$ of an inch. This central aperture is covered on its upper side by a disk of thin glass, which may be cemented to the brass plate by Canada balsam; and the under side of it is bevelled-away, so that the thickness

of the edge shall not interfere with the approach of the objective to its margin, when that side is made the uppermost — Near one extremity of the plate is a strong vertical pin, that gives support to a horizontal bar which turns on it as on a swivel; through the end of this bar that projects beyond the plate, there passes a screw with a milled-head; and at the other end is jointed a second bar, against one end of which the screw bears, whilst the other carries a frame holding a second disk of thin glass. This frame is a small circular plate of glass, having an aperture equal in size to that of the large plate; to its under side, which is flat, a disk of thin glass is cemented by Canada balsam, while its upper side is bevelled-off as it approaches the opening, for the purpose just now specified; and by being swung between pivots in a semicircle of brass, which is itself pivotted to the movable arm, it is made capable of a limited movement in any direction. The upper disk with the apparatus which supports it, having been completely turned aside round the swivel-joint, the object to be compressed is laid upon the lower disk; the upper disk is then turned back so as to lie precisely over it, and, by the action of the milled-head screw, is gradually approximated to the lower, to which the pivot-movements of its frame allow it to take-up a parallel position, whatever may be the inclination of the bar.—As it is frequently of great importance to be able to look at either side of the object under compression, the principal plate is provided with two pins at the extremity farthest from the milled-head, which, being exactly equal in length to the swivel-pin, afford, with it, a support to the instrument, when it is so turned that the side represented as undermost in the figure, shall be uppermost; and it is in order that high powers may be used in this case as in the other, that the disk which then covers the object is made of thin glass, instead of being (as in the original form of the instrument) a piece of thick glass plate. That a thin glass disk is more liable to fracture under pressure, than a thick one, is no serious objection to its use for this purpose; since the lower one is not more likely to break than the upper one; and either may be replaced with extreme facility, by simply warming the part of the instrument to which it is attached, so as to loosen the cement that holds it. And the advantage of being able to view an object under a high power, *from either side*, will be most fully appreciated by every one who has been much engaged in the class of observations, which this instrument is specially adapted to facilitate.—If this Compressorium be made of sufficient size

●

to admit an ordinary glass slide between the vertical pins, an object may be subjected to compression, and afterwards removed for examination out of the compressor, without transferring it from one glass to another, which is frequently an advantage. In this case, it will be convenient that the thin glass disk should be 'countersunk' into the upper surface of the principal plate, so as to form one level with it.

FIG. 51.

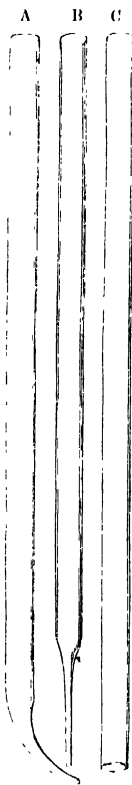

Fishing Tubes.

71. *Dipping Tubes.*—In every operation in which small quantities of liquid, or small objects contained in liquid, have to be dealt with by the Microscopist, he will find it a very great convenience to be provided with a set of tubes of the forms represented in Fig. 51, but of somewhat larger dimensions. These were formerly designated as 'fishing-tubes;' the purpose for which they were originally devised having been the fishing-out of Water-Fleas, aquatic Insect-Larvæ, the larger Animalcules, or other living objects distinguishable either by the unaided eye or by the assistance of a magnifying glass, from the vessels that may contain them. But they are equally applicable, of course, to the selection of minute Plants; and they may be turned to many other no less useful purposes, some of which will be specified hereafter. When it is desired to secure an object which can be seen either with the eye alone or with a magnifying-glass, one of these tubes is passed-down into the liquid, its upper orifice having been previously closed by the fore-finger, until its lower orifice is close above the object; the finger being then removed, the liquid suddenly rises into the tube, probably carrying the object up with it; and, if this is seen to be the case, by putting the finger again on the top of the tube, its contents remain in it when the tube is lifted-out, and may be deposited on a slip of glass or on the lower disk of the aquatic box, or, if too

copious for either receptacle, may be discharged into a watch-glass. In thus fishing for any but the minutest objects, it will be generally found convenient to employ the open-mouthed tube c; and when its contents have been discharged, if they include but a single object of the desiderated kind, this may be taken-up by one of the finer tubes, A, B, or, if more convenient, the whole superfluous fluid may be sucked-up by the mouth, and the object left with no more than is suitable; or, if there be many of the desired objects in the fluid first selected, these may be taken-up from it, one by one, by either of the finer tubes.

72. *Forceps*.—Another instrument so indispensable to the Microscopist as to be commonly considered an appendage to the Microscope, is the Forceps for taking-up minute objects; many forms of this have been devised, of which one of the most convenient is represented in Fig 52, of something

FIG. 52



Forceps.

less than the actual size. As the forceps, in marine researches, have continually to be plunged into sea-water, it is better that they should be made of brass or of German-silver, than of steel, since the latter rusts far more readily; and as they are not intended (like dissecting forceps) to take a firm grasp of the object, but merely to hold it, they may be made very light, and their spring-part slender. As it is essential, however, to their utility, that their points should meet accurately, it is well that one of the blades should be furnished with a guide-pin, passing through a hole in the other.

The foregoing constitute, it is believed, all the most important pieces of Apparatus, which can be considered in the light of Accessories to the Microscope. Those which have been contrived to afford facilities for the preparation and mounting of Objects, will be described in a future chapter (Chap. v.).—It may be thought that some notice ought to be taken of the *Frog Plate* and *Fish-Pan*, with the former of

which many Microscopes are supplied, whilst the latter has scarcely yet gone altogether out of use. But the Author having been accustomed to gain all the advantages of these, by methods far more simple, whilst at least equally efficacious, does not consider them as presenting any advantages which render it desirable to expend time or space in giving a detailed account of them ; and he will explain the methods alluded-to, under the appropriate head.

CHAPTER IV.

MANAGEMENT OF THE MICROSCOPE.

73. *Support.*—The Table on which the Microscope is placed, when in use, should be one whose size enables it also to receive the various appurtenances which the observer finds it convenient to have within his reach, and whose steadiness is such as to allow of his arms being rested upon it without any yielding; it should, moreover, be so framed, as to be as free as possible from any tendency to transmit the vibrations of the building or floor whereon it stands.* The manner in which the Microscope itself is constructed, however, will have a great influence on the effect of any such disturbing cause; since, if the whole instrument move together, scarcely any tremulousness will be produced in the image, by vibrations which cause it to ‘dance’ most unpleasantly, if the body and the stage of the Microscope oscillate independently of each other. Hence, in choosing a Microscope, it should always be subjected to this test, and should be unhesitatingly rejected if the result be unfavourable. It is of course to be borne in mind, that any vibration, either of the object or of the optical apparatus, in which the other does not partake, will be much more apparent when high magnifying powers are used, than when the object is amplified in a much less degree, the motion of the object being magnified in precisely the same ratio with the object itself; hence if, when the microscope is thus tested with high powers, it is found to be free from fault, its steadiness with low powers may be assumed; but, on the other hand, a Microscope which may give an image free from

* The working Microscopist will find it a matter of great convenience to have a Table specially set-apart for this purpose; furnished with drawers in which are contained the various accessories he may require for the preparation and mounting of objects. If the Microscope be one which is not very readily taken-out-from and put-back-into its case, it is very convenient to cover it with a large bell-glass; which may be so suspended from the ceiling, by a cord carrying a counterpoise at its other end, as to be raised or lowered with the least possible trouble, and to be entirely out of the way when the Microscope is in use. Similar but smaller bell-glasses are also useful for the protection of objects, which are in course of being examined or prepared, and which it is desirable to seclude from dust.

perceptible tremor when the lowest powers only are employed, may be quite unfit for use with the highest.

74. *Light*.—Whatever may be the purposes to which the Microscope is applied, it is a matter of the first importance to secure a pure and adequate illumination. There is scarcely any class of objects, for the examination of which *good daylight* is not to be preferred to any other kind of light; but *good lamp-light* is preferable to bad day-light.—When daylight is employed, the Microscope should be placed near a window, whose aspect should be (as nearly as may be convenient) *opposite* to the side on which the sun is shining; for the light of the sun reflected from a bright cloud, is that which the experienced Microscopist will almost always prefer, the rays proceeding from a cloudless blue sky being by no means so well fitted for his purpose, and the dull lurid reflection of a dark cloud being the worst of all. The *direct* rays of the sun are far too powerful to be used with advantage, unless its intensity be moderated, either by reflection from a plaster-of-paris or some other ‘white-cloud’ mirror (§ 58), or by passage through some imperfectly-transparent medium. The *moderator* contrived by Mr. Rainey for lamp or gas-light (§ 75), has been found to answer equally well for direct sun-light; the glare and heating power of which it so effectually subdues, as to destroy all tendency to injure the most delicate object, or to confuse the observer’s view of it; whilst an illumination is obtained by its means, whose intensity renders it superior for certain purposes to anything else.—The young Microscopist is earnestly recommended to make as much use of *daylight* as possible; not only because, in a large number of cases, the view of the object which it affords is more satisfactory than that which can be obtained by any kind of lamp-light, but also because it is much less ‘trying’ to the eyes. So great, indeed, is the difference between the two in this respect, that there are many who find themselves unable to carry-on their observations for any length of time by lamp-light, although they experience neither fatigue nor strain from many hours’ continuous work by daylight.

75. When recourse is had to Artificial light, it is of great importance, not only that it should be of good quality, but that the arrangement for furnishing it should be suitable to the special wants of the Microscopist. Thus, although a wax or composition-candle affords a very pure light, yet its use is attended with two inconveniences, which render its use very undesirable when any better light can be obtained;—namely,

the constant flickering of the flame, which is not sufficiently prevented by surrounding it with a chimney; and the continual alteration in its level, which is occasioned by the consumption of the candle. The most useful light for ordinary use, is that furnished by the steady and constant flame of a lamp, fed either with oil, camphine, or gas; the wick or burner should be cylindrical or 'argand;' it should be capable of adjustment to any height above the table; and a movable shade should be provided, by which the light may be prevented from coming direct to the observer's eyes, or from diffusing itself too widely through the room. These requisites are supplied by the lamp commonly known as the 'University' or 'reading' lamp, which has a circular foot with a vertical stem, on which the oil-reservoir (carrying with it the burner) and the shade, can be fixed at any convenient height. French and German lamps on the same general construction, but having the reservoir contrived on the 'bird-fountain' principle, are also to be obtained, being largely imported for the use of watchmakers; these have the advantage of burning-out all their oil, which is not the case with the ordinary 'reading'-lamp, as it does not burn well except when full or nearly so; but they are usually destitute of a shade, which, however, can be easily added. Lamps of either kind are sometimes constructed on the 'solar' principle, which increases the purity and intensity of the light, but at the same time not only diminishes the diameter of the flame, but also produces an inconvenient transverse 'break' near its lower part. The best kind of light which an oil-lamp can furnish, is that yielded by the 'Moderator' lamps which have of late come into such general use; but they have this important drawback, that they contain in themselves no adjustment for varying the elevation of the burner, and that their construction is such as to give no facilities for any arrangement of this kind.—The same objection applies to the Camphine-lamps in ordinary use; but a small camphine-lamp has been constructed for the special use of Microscopists, which is capable of being placed on an adjustable stand, so that its flame may be raised or lowered to any desired level. The light of this lamp is whiter and more intense than that of any other, and it may be used with advantage for certain very delicate observations (§ 58); but for the ordinary purposes of the Microscopist it is not so convenient, the surface of flame from which the light can be received by the mirror or condenser, being limited by the peculiar construction which the combustion of camphine requires.—To every one who has a supply of Gas at

command, the use of it for his microscope-lamp (by means of a flexible tube) strongly recommends itself, on account of its extreme convenience, and its freedom from any kind of trouble. The lamp should be constructed on the general plan already described, the burner being made to slide up and down on a stem rising perpendicularly from a foot, which also carries a shade; and the burner should be one which affords a bright and steady cylindrical flame, either 'Leslie's' or the 'cone' burner being probably the best. Even the best light supplied by a gas-lamp, however, is inferior in quality to that of a good oil-lamp; and is more injurious and unpleasant to the eye. Hence the interposition of some kind of artificial medium, adapted to keep-back the yellow rays, whose predominance in the lamp-flame is the chief source of its injurious action, is especially required when gas-light is used. This may be partly effected, by the simple expedient of using a chimney of bluish glass, known as 'Leblond's;' but, in addition, it is advantageous to cause the light to pass through a screen of bluish-black or neutral-tint glass; and it will then be nearly purified as to quality, though much reduced in intensity.* Mr. Rainey, who has paid great attention to the best means of obtaining a good illumination by artificial light, recommends, as the best *moderator*, one piece of dark blue glass, free from any tint of red, another of very pale blue with a slight shade of green, and two of thick white plate-glass, all cemented together with Canada balsam; this, as already stated, may be used with sun light, as well as with lamp-light. The Microscopist who wishes to render the artificial light which he may be in the habit of using, as pure as possible, will do well to compare it with daylight (as suggested by Dr. Griffith, who seems to have been the first to employ tinted glass with this object); furnishing himself with several pieces of glass of different shades, substituting one for another, and altering their distances from the lamp,† until he has succeeded in so tempering its rays, that the field of his Microscope, or the object under view, is not more coloured when illuminated by the artificial

* A gas-lamp provided with these and other appurtenances for regulating the illumination, and also with a water-bath and mounting-plate, is supplied by Mr. S. Highley, Fleet-street.

† The nearer the coloured glass is approximated to the flame, the less modification will it produce in its rays; since *their* intensity varies in different parts of their course, inversely with the square of their distance from the illuminating centre, whilst *its* influence is a constant quantity. Hence a pale-blue glass placed near the mirror, or between the mirror and the stage, has more effect than a chimney of much deeper blue immediately surrounding the flame.

light reflected from the mirror, than it is when the mirror is so turned as to reflect a good light from a white cloud.

76. *Position of the Light.*—When the Microscope is used by day-light, it will usually be found most convenient to place it in such a manner, that the light shall be at the left-hand of the observer. It is most important that no light should enter his eye, save that which comes to it through the Microscope; and the access of direct light can scarcely be avoided, when he sits with his face to the light. Of the two sides, it is more convenient to have the light on the *left*; first, because it is not interfered-with by the right hand, when this is employed in giving the requisite direction to the mirror, or in adjusting the illuminating apparatus; and secondly, because, as most persons employ the right eye rather than the left, the projection of the nose serves to cut-off those lateral rays, which, when the light comes from the right side, glance between the eye and the eye-piece. In order to prevent, still more completely, the access of false light, it is desirable, if it be otherwise convenient, that when daylight is employed, its source should be a little behind the observer; but as it will then, by falling upon the stage, interfere with the view of any object which is imperfectly-transparent (§ 87), it may be necessary to keep it from doing so, by the interposition of a screen.—When artificial light is employed, the same general precautions should be taken. The lamp should always be placed on the left side, unless the use of the mirror be dispensed-with, or some special reason exist for placing it otherwise. If the object under examination be transparent, the lamp should be placed at a distance from the eye about midway between that of the stage and that of the mirror; if on the other hand, the object be opaque, it should be at a distance about midway between the eye and the stage; so that its light may fall, in the one case upon the mirror, in the other case upon the stage, at an angle of about 15° with the axis of the microscope. The passage of direct rays from the flame to the eye, should be guarded-against by the interposition of the lamp-shade; and no more light should be diffused through the apartment, than is absolutely necessary for other purposes.—If observations of a very delicate nature are being made, it is desirable, alike by daylight and by lamp-light, to exclude all lateral rays from the eye, as completely as possible; and this may be readily accomplished, by means of a *shade* attached to the eye-piece of the microscope. Such a shade may be made most simply of an oblong piece of card-

board, having a circular hole cut in it, by which it may fit upon the eye-piece or the upper part of the body; its two ends should be turned-up, so as to cut-off all lateral light; its upper side should also be turned-up, so as to cut-off the light from the front; and a notch should be cut in its lower edge, in the proper position to receive the nose. It may be either painted black, or may be covered with black cloth or velvet.

77. *Care of the Eyes.*—Although most Microscopists acquire a habit of employing only *one* eye (generally the right), yet it will be decidedly advantageous to the beginner, that he should learn to use either eye indifferently; since by employing and resting each alternately, he may work much longer, without incurring unpleasant or injurious fatigue, than when he always employs the same.—Whether or not he do thus, he will find it of great importance to acquire the habit of *keeping open the unemployed eye*. This, to such as are unaccustomed to it, seems at first very embarrassing, on account of the interference with the microscopic image, which is occasioned by the picture of surrounding objects, formed upon the retina of the second eye; but the habit of restricting the attention to that impression only which is received through the microscopic eye, may generally be soon acquired; and when it has once been formed, all difficulty ceases. Those who find it unusually difficult to acquire this habit, may do well to learn it in the first instance with the assistance of the shade just described; the employment of which will permit the second eye to be kept open without any confusion. The advantage of the practice, in diminishing the fatigue of long-continued observation, is such, that no pains are ill bestowed by the Microscopist, which are devoted to early habituation to it.—There can be no doubt that the habitual use of the Microscope for many hours together, especially by lamp-light, and with high magnifying powers, has a great tendency to injure the sight. Every Microscopist who thus occupies himself, therefore, will do well, as he values his eyes, not merely to adopt the various precautionary measures already specified, but rigorously to observe the simple rule of *not continuing to observe, any longer than he can do so without fatigue*.

78. *Care of the Microscope.*—Before the Microscope is brought into use, the cleanliness and dryness of its glasses ought to be ascertained. If dust or moisture should have settled on the Mirror, this can be readily wiped-off. If any spots should show themselves on the field of view, when it is

illuminated by the mirror, these are probably due to particles adherent to one of the lenses of the Eye-piece; and this may be determined by turning the eye-piece round, which will cause the spots also to rotate, if their source lies in it. It may very probably be sufficient to wipe the upper surface of the eye-glass (by removing its cap), and the lower surface of the field-glass; but if, after this has been done, the spots should still present themselves, it will be necessary to unscrew the lenses from their sockets, and to wipe their inner surfaces; taking care to screw them firmly into their places again, and not to confuse the lenses of different eye-pieces. Sometimes the eye-glass is obscured by dust of extreme fineness, which may be carried-off by a smart puff of breath: the vapour which then remains upon the surface being readily dissipated, by rapidly moving the glass backwards and forwards a few times through the air. And it is always desirable to try this plan in the first instance; since, however soft the substance with which the glasses are wiped, their polish is impaired in the end by the too frequent performance of the process. The best material for wiping glass, is a piece of soft wash-leather, from which the dust it generally contains has been well beaten-out.—If the Object-glasses be carefully handled, and be kept in their boxes when not in use, they will not be likely to require cleansing. One of the chief dangers, however, to which they are liable in the hands of an inexperienced Microscopist, arises from the neglect of precaution in using them with fluids; which, when allowed to come in contact with the surface of the outer glass, should be wiped-off as soon as possible. In screwing and unscrewing them, great care should be taken to keep the glasses at a distance from the surface of the hands; since they are liable not only to be soiled by actual contact, but to be dimmed by the vaporous exhalation from skin which they do not touch. This dimness will be best dissipated, by moving the glass quickly through the air. It will sometimes be found, on holding an object-glass to the light, that particles either of ordinary dust, or more often of the black coating of the interior of the microscope, have settled upon the surface of its back-lens; these are best removed by a clean and dry camel-hair pencil. If any cloudiness or dust should still present itself in an object-glass, after its front and back surfaces have been carefully cleansed, it should be sent to the maker (if it be of English manufacture) to be taken to pieces, as the amateur will seldom succeed in doing this without injury to the work;

the foreign combinations, however, being usually put-together in a simpler manner, may be readily unscrewed, cleansed, and screwed-together again. Not unfrequently an objective is rendered dim by the cracking of the cement by which the lenses are united, or by the insinuation of moisture between them; this last defect occasionally arises from a fault in the quality of the glass, which is technically said to 'sweat.' In neither of these cases has the Microscopist any resource, save in an Optician experienced in this kind of work; since his own attempts to remedy the defect are pretty sure to be attended with more injury than benefit.

79. *General Arrangement of the Microscope for Use.*—The inclined position of the instrument, already so frequently referred-to, is that in which Observation by it can be so much more advantageously carried-on than it can be in any other, that this should always be had-recourse-to, unless particular circumstances render it unsuitable. The precise inclination that may prove to be most convenient, will depend upon the 'build' of the Microscope, upon the height of the observer's seat as compared with that of the table on which the instrument rests, and lastly, upon the tallness of the individual; and it must be determined in each case by his own experience of what suits him best,—that which he finds *most comfortable*, being that in which he will be able not only to work the longest, but to see most distinctly.—The selection of the object-glasses and eye-pieces to be employed, must be entirely determined by the character of the object. Large objects presenting no minute structural features, should always be examined in the first instance by the *lowest* powers, whereby a general view of their nature is obtained; and since, with lenses of comparatively long focus and small angle of aperture, the precision of the focal adjustment is not of so much consequence as it is with the higher powers, not only those parts can be seen which are exactly in focus, but those also can be tolerably well distinguished, which are not precisely in that plane, but are a little nearer or more remote. When the general aspect of an object has been sufficiently examined through low powers, its details may be scrutinized under a higher amplification; and this will be required in the first instance, if the object be so minute, that little or nothing can be made-out respecting it, save when a very enlarged image is formed. The power needed in each particular case, can only be learned by experience; that which is most suitable for the several classes of objects hereafter to be described, will be specified

under each head.—In the general examination of the larger class of objects, the range of power that is afforded by the ‘erector’ in combination with the ‘draw-tube’ (§ 14), will be found very useful; whilst for the ready exchange of a low power for a high one, great convenience is afforded by Mr. Brooke’s object-glass holder (§ 50).

80. When the Microscopist wishes to augment his magnifying power, he has a choice between the employment of an Objective of shorter focus, and the use of a deeper Eye-piece. If he possess a complete series of objectives, he will generally find it best to substitute one of these for another, without changing the eye-piece for a deeper one; but if his ‘powers’ be separated by wide intervals, he will be able to break the abruptness of the increase in amplification which they produce, by using each objective first with the shallower, and then with the deeper eye-piece. Thus if a Microscope be only provided with two objectives, of 1 inch and 1-4th inch focus respectively, and with two eye-pieces, one nearly double the power of the other (as will be the case with Messrs. Smith and Beck’s new Educational Microscope, p. 89 *note*), such a range as the following may be obtained,—55, 100, 200, 350 diameters; or, with two objectives of somewhat shorter focus, and with deeper eye-pieces (as is the case with an instrument in the Author’s possession, constructed by Kellner of Wetzlar, whose Microscopes have acquired for themselves a deservedly-high reputation),—88, 176, 350, 700 diameters. The use of the ‘draw-tube’ (§ 43) enables the Microscopist still further to vary the magnifying power of his instrument, and thus to obtain almost any exact number of diameters he may desire, within the limits to which he is restricted by the focal length of his objectives. The advantage to be derived, however, either from ‘deep eye-piecing,’ or from the use of the draw-tube, will mainly depend upon the quality of the object-glass. For if it be imperfectly corrected, its errors are so much exaggerated, that more is lost in definition than is gained in amplification; whilst, if its aperture be small, the loss of light is an equally serious drawback. On the other hand, a combination of perfect construction and wide angle of aperture, will sustain this treatment with so little impairment in the perfection of its image, that a magnifying power may be obtained by its use, such as, with an inferior instrument, can only be derived from an objective of much shorter focus combined with a shallow

eye-piece.* In making any such comparisons, it must be constantly borne in mind that the real question is, *what can be seen?* It is always desirable for the purposes of research, to employ the *lowest* power with which the details of structure can be clearly made-out; since, the lower the power, the less is the liability to error from false appearances, and the better can the mutual relations of the different parts of the object be appreciated. Hence in testing the optical quality of a Microscope, the question should always be,—not, what is its *greatest* magnifying power,—but, what is the *least* magnifying power under which it will show objects of a given degree of difficulty.

81. In making the Focal Adjustment, when low powers are used, it will scarcely be necessary to employ any but the *coarse movement*, provided that the rack be well cut, the pinion work in it smoothly and easily, without either ‘spring,’ ‘loss of time,’ or ‘twist,’ and the milled-head be large enough to give the requisite leverage. All these are requisites which should be found in every well-constructed instrument; and its possession of them should be tested, like its freedom from vibration, by the use of high powers, since a really-good coarse adjustment should enable the observer to ‘focus’ an objective of 1-8th inch with precision. What is meant by ‘spring’ is the alteration which may often be observed to take place on the withdrawal of the hand; the object which has been brought precisely into focus, and which so remains as long as the milled-head is between the fingers, becoming indistinct when the milled-head is let-go. The source of this fault may be either in the rack-movement itself, or in the general framing of the instrument, which is so weak as to allow of displacement by the mere weight or pressure of the hand; should the latter be the case, the ‘spring’ may be in great degree prevented, by carefully abstaining from *bearing-on* the milled-head, which should be simply *rotated* between the fingers. By ‘loss of time’ is meant the want of sufficient readiness in the action of the pinion upon the rack, so that the milled-head may be moved a little in either direction, without affecting the body; thus occasioning a great diminution in the sensitiveness of the adjustment. This fault may sometimes be detected in Microscopes of the best original construction,

* The 1-10ths object-glass of Messrs Smith and Beck was specially distinguished by the Jurors of the Great Exhibition, as affording, by the use of deep eye-pieces and the draw-tube, a power fully equivalent in the resolution of difficult tests, to that which a few years previously could only have been given by an objective of 1-8th inch.

which have gradually worked-loose, from the constancy with which they have been in employment; and it may often be corrected by tightening the screws that bring the pinion to bear against the rack. And by 'twist' it is intended to express that apparent movement of the object across the field, which results from a real displacement of the axis of the body to one side or the other, owing to a want of correct fitting in the working parts. As this last fault depends entirely on bad original workmanship, there is no remedy for it; but it is one which most seriously interferes with the convenient use of the instrument, however excellent may be its optical performance.—In the use of the coarse adjustment with an objective of short focus, extreme care is necessary to avoid bringing it down upon the object, to the injury of one or both; for although the spring with which the tube for the reception of the object-glass is furnished, whenever the fine adjustment is immediately applied to this (§ 31), takes-off the violence of the crushing action, yet such an action, even when thus moderated, can scarcely fail to damage or disturb the object, and *may* do great mischief to the lenses. Where no such spring-tube is furnished, the fine adjustment being otherwise provided-for, or being not supplied at all, still greater care is of course required. It is here, perhaps, well to notice, for the guidance of the young Microscopist, that the *actual* distance between the object-glass and the object, when a distinct image is formed, is always considerably less than the *nominal* focal length of the object-glass; thus, the distance of the 1 inch or 2-3 inch object-glass may be little more than half an inch; that of the 4-10 inch may be but little more than one-tenth of an inch; that of a 1-1 or a 1-5 inch may scarcely exceed one-twentieth; that of a 1-8 inch may not be one-fortieth; and that of a 1-12 or a 1-16 inch may be so close as not to admit the intervention of a piece of glass no more than one-hundredth of an inch in thickness. The reason of this is, that the focal length of an Achromatic objective is estimated by that of the Single lens with which it agrees in the size of the image it forms, and therefore in magnifying power (*e. g.*, it is said to be of 1 inch focus, when its power is equivalent to that of a single lens, which brings parallel rays to a point at an inch distance); whilst from its being composed of a combination of lenses, the point from which that focal *distance* has really to be measured, is not at the surface of its front lens, but at some distance behind it, in the interior of the combination.—One more precaution it

may be well to specify;—namely, that either in changing one object for another, or in substituting one objective for another, save when powers of such focal length are employed as to remove all likelihood of injury, the ‘body’ should be turned to one side, where the construction of the Microscope admits of this displacement, or (where it does not) should have its distance from the stage increased by the ‘coarse movement.’ This precaution is absolutely necessary, when objectives of short focus are in use, to avoid injury either to the lenses or to the object; and when it is habitually practised with regard to these, it becomes so much like an ‘acquired instinct,’ as to be almost invariably practised in other cases.

82. In obtaining an exact Focal Adjustment with object-glasses of less than half an inch focus, it will be generally found convenient to employ the *fine movement*; and as recourse will frequently be had to its assistance for other purposes also, it is very important that it should be well constructed and in good working order. The points to be particularly looked-to in testing it, are for the most part the same with those already noticed in relation to the coarse movement. It should work smoothly and equably, producing that *graduated* alteration of the distance of the object-glass from the object, which it is its special duty to effect, without any jerking or irregularity. It should be so sensitive, that any movement of the milled-head should at once make its action apparent, by an alteration in the distinctness of the image, when high powers are employed, without any ‘loss of time.’* And its action should not give rise to any twisting or displacing movement of the image, which ought not to be in the least degree disturbed by any number of rotations of the milled-head, still less, by a rotation through only a few degrees.—One great use of the ‘fine adjustment’ consists in bringing into view different *strata* of the object, and this in such a gradual manner that their connection with one another shall be made apparent. Whether an opaque or a transparent object be under examination, only that part can be perfectly discerned under any power, which is exactly in focus; and when high powers of large aperture are employed, this is the only part that can be seen at all. A minute alteration of the focus often

* It will sometimes happen that the ‘fine movement’ will seem not to act, merely because it has been so habitually worked in one direction rather than the other, that its screw has been turned too far. In that case, nothing more is required for its restoration to good working order, than turning the screw in the other direction, until it shall have reached about the middle of its range of action.

causes so entirely-different a set of appearances to be presented, that, if this alteration be made abruptly, their relation to the preceding can scarcely be even guessed-at; and the gradual transition from the one to the other, which the fine adjustment alone affords, is therefore necessary to the correct interpretation of either. To take a very simple case:—The transparent body of a certain animal being traversed by vessels lying in different planes, one set of these vessels is brought into view by one adjustment, another set by ‘focussing’ to a different plane; and the connection of the two sets of vessels, which may be the point of most importance in the whole anatomy of the animal, may be entirely overlooked, for want of a fine adjustment, the graduated action of which shall enable one to be traced continuously into the other. What is true even of low and medium powers, is of course true to a still greater degree of high powers; for although the ‘coarse movement’ *may* enable the observer to bring any stratum of the object into accurate focus, it is impossible for him by its means to secure that *transitional* ‘focussing,’ which is often so much more instructive than an exact adjustment at any one point. A clearer idea of the nature of a doubtful structure is, in fact, often derived from what is caught-sight-of *in the act* of changing the focus, than by the most attentive study and comparison of the different views obtained by any number of separate ‘focussings.’ The experienced Microscopist, therefore, when examining an object of almost any description, constantly keeps his finger upon the milled-head of the ‘fine movement,’ and watches the effect produced by its revolution upon every feature which he distinguishes; never leaving off, until he be satisfied that he has scrutinized not only the entire *surface*, but the entire *thickness* of the object. It will often happen, that, where different structural features present themselves on different planes, it will be difficult or even impossible to determine which of them is the nearer and which the more remote (it being the special result of the ordinary mode of viewing objects by transmitted light, that such differences are obliterated), unless, by the use of the ‘fine movement,’ it be ascertained, when they are successively brought into focus, whether the object-glass has been moved *towards* or *away-from* the object. Even this, however, will not always succeed in certain of the most difficult cases, in which the difference of level is so slight as to be almost inappreciable;—as, for instance, in the case of the markings on the siliceous *loricæ* of the Diatomaceæ (Fig. 80).

83. When Objectives of short focus and of wide angular aperture are being employed, something more is necessary than exact focal adjustment; this being the *Adjustment of the Object-glass* itself, which is required to neutralize the disturbing effect of the glass cover upon the course of the rays proceeding from the object (§ 15). For this adjustment, it will be recollected, a power of altering the distance between the front pair and the remainder of the combination is required; and this power is obtained in the following manner. The front pair of lenses is fixed into a tube (Fig. 53, A), which

FIG. 53.

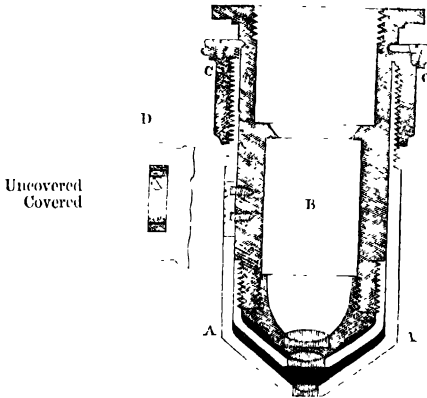

Section of an Adjusting Object-glass.

slides over an interior tube (B) by which the other two pairs are held; and it is drawn up or down by means of a collar (C), which works in a furrow cut in the inner tube, and upon a screw-thread cut in the outer, so that its revolution in the plane to which it is fixed by the one tube, gives a vertical movement to the other. In one part of the outer tube, an oblong slit is made, as seen at D, into which projects a small tongue, screwed on the inner tube; at the side of the former two horizontal lines are engraved, one pointing to the word 'uncovered,' the other to the word 'covered;' whilst the latter is crossed by a horizontal mark, which is brought to coincide with either of the two lines by the rotation of the screw-

collar, which moves the outer tube up or down. When the mark has been made to point to the line 'uncovered,' it indicates that the distance of the lenses of the object-glass is such, as to make it suitable for viewing an object without any interference from thin glass: when, on the other hand, the mark has been brought, by the revolution of the screw-collar, into coincidence with the line 'covered,' it indicates that the front lens has been brought into such proximity with the other two, as to produce a 'positive aberration' in the objective, fitted to neutralize the 'negative aberration' produced by the interposition of a glass cover of a certain thickness. It is evident, however, that unless the particular thickness of glass for which this degree of alteration is suited, be always employed for this purpose, the correction cannot be exact; and means must be taken for adapting it to every grade of thickness, which may be likely to present itself in the glass-covers. Unless this correction be made with the greatest precision, the enlargement of the angle of aperture, to which our Opticians have of late applied themselves with such remarkable success, becomes worse than useless; being a source of diminished instead of increased distinctness in the details of the object, which are far better seen with an objective of greatly inferior aperture, possessing no special adjustment for the thickness of the glass. The following general rule is given by Mr. Wenham, for securing the most efficient performance of an object-glass with any ordinary object.—“Select any dark speck or opaque portion of the object, and bring the outline into perfect focus; then lay the finger on the milled-head of the fine motion, and move it briskly backwards and forwards in both directions from the first position. Observe the expansion of the dark outline of the object, both when within, and when without, the focus. If the greater expansion, or coma, is when the object is *without* the focus, or furthest from the objective, the lenses must be placed further asunder, or towards the mark 'uncovered.' If the greater coma is when the object is *within* the focus, or nearest to the objective, the lenses must be brought closer together, or towards the mark 'covered.' When the object-glass is in proper adjustment, the expansion of the outline is exactly the same both within and without the focus.” A different indication, however, is afforded by such 'test-objects' as present (like the Podura-scale and the Diatomææ) a set of distinct dots or other markings. For “if the dots have a tendency to run into lines when the object is placed *without* the focus, the

glasses must be brought closer together; on the contrary, if the lines appear when the object is *within* the focal point, the object must be further separated* When the angle of aperture is very wide, the difference in the aspect of any severe test under different adjustments becomes at once evident; markings which are very distinct when the correction has been exactly made, disappearing almost instantaneously when the screw-collar is turned a little way round.†

84. Although the *most perfect* correction required for each particular object (which depends, not merely upon the thickness of its glass-cover, but upon that of the fluid or balsam in which it may be mounted) can only be found by experimental trial, yet for all ordinary purposes, the following simple method, first devised by Mr. Powell, will suffice. The object-glass, adjusted to 'uncovered,' is to be 'focussed' to the object; its screw-collar is next to be turned, until the surface of the glass-cover comes into focus, as may be perceived by the spots or striae by which it may be marked; the object is then to be again brought into focus by the 'fine movement.' The edge of the screw-collar being now usually graduated, the particular adjustment which any object may have been found to require, and of which a record has been kept, may be made again without any difficulty. By Messrs. Smith and Beck, however, who first introduced this graduation, a further use is made of it. By experiments such as those described in the last paragraph, the correct adjustment is first found for any particular object, and the number of divisions observed, through which the screw-collar must be moved in order to bring it back to 0°, the position suitable for an uncovered object. The thickness of the glass-cover must then be measured by means of the 'fine movement;' this is done by bringing into exact focus, first the object itself, and then the surface of the glass-cover, and by observing the number of divisions through which the milled-head (which is itself graduated) has passed in making this change. A definite

* See "Quart. Journ. of Microsc. Science," vol. ii p. 138.

† Mr. Wenham remarks (*loc. cit.*), not without justice, upon the difficulty of making this adjustment, even in the Objective of our best Opticians, and he states that he has himself succeeded much better, by making the outer tube the fixture, and by making the tube that carries the other parts slide within this, the motion being given by the action of an inclined slit in the revolving collar, upon a pin that passes through a longitudinal slit in the outer tube, to be attached to the inner. The whole range of adjustment is thus performed within a third part of a revolution, with scarcely any friction, and with such an immediate transition from good to bad definition, that the best point is made readily apparent.

ratio between that thickness of glass, and the correction required in that particular objective, is thus established; and this serves as the guide to the requisite correction for any other thickness, which has been determined in like manner by the 'fine-movement.' Thus, supposing a particular thickness of glass to be measured by 12 divisions of the milled-head of the fine movement, and the most perfect performance of the object-glass to be obtained by moving the screw-collar through 8 divisions, then a thickness of glass measured by 9 divisions of the milled-head, would require the screw-collar to be adjusted to 6 divisions in order to obtain the best effect. The ratio between the two sets of divisions is by no means the same for different combinations; and it ought to be determined for each objective by its maker, who will generally be the best judge of the best 'points' of his lenses; but when this ratio has been once ascertained, the adjustment for any thickness of glass with which the object may happen to be covered, is readily made by the Microscopist himself.—Although this method appears somewhat more complex than that of Mr. Powell, yet it is more perfect; and when the ratio between the two sets of divisions has been once determined, the adjustment does not really involve more trouble—Another use is made of this adjustment by Messrs. Smith and Beck; namely, to correct the performance of the objectives, which is disturbed by the increase of distance between the objective and the eye-piece, that is occasioned by the use of the draw-tube (§ 43). Accordingly, they mark a scale of inches on the draw-tube (which is useful for many other purposes), and direct that for every inch the body is lengthened, the screw-collar of the objective shall be moved through a certain number of divisions.

85. *Arrangement for Transparent Objects*—If the object be already 'mounted' in a slide, nothing more is necessary, in order to bring it into the right position for viewing it, than to lay the slide upon the object-platform of the stage, and to support it in such a position (by means of the sliding ledge or other contrivance) that the part to be viewed is, as nearly as can be guessed, in the centre of the aperture of the stage, and therefore in a line with the axis of the body. If the object be not 'mounted,' and be of such a kind that it is best seen dry, it may be simply laid upon the glass stage-plate (§ 67), the ledge of which will prevent it from slipping-off when the microscope is inclined, and a plate of thin glass may be laid over it for its protection, if its delicacy should seem to

render this desirable. If, again, it be disposed to curl-up, so that a slight pressure is needed to flatten or extend it, recourse may be had to the use of the aquatic box (§ 68) or of the compressorium (§ 70), no liquid, however, being introduced between the surfaces of glass. In a very large proportion of cases, however, either the objects to be examined are already floating in fluid, or it is preferable to examine them in fluid, on account of the greater distinctness with which they may be seen; if such objects be minute, and the quantity of liquid be small, the drop is simply to be laid on a slip of glass, and covered with a plate of thin glass; if the object or the quantity of liquid be larger, it will be better to place it in the aquatic box; whilst, if the object have dimensions which render even this inconvenient, the zoophyte-trough (§ 69) will afford the best medium for its examination. If it be wished to have recourse to *compression*, for the expansion or flattening of the object, this may be made upon the ordinary slide, by pressing-down the thin-glass cover with a pointed stick; and this method, which allows the pressure to be applied where it may chance to be most required, will generally be found preferable for delicate portions of tissue which are easily spread-out, and which, in fact, require little other compression than is afforded by the weight of the glass cover, and by the capillary attraction which draws it into proximity with the slide beneath. A firmer and more enduring pressure may be exerted by the dexterous management of a well-constructed aquatic box; and this method is peculiarly valuable for confining the movements of minute animals, so as to keep them at rest under the field of the microscope, without killing them. It is where a firm but graduated pressure is required, for the flattening-out of the bodies of thin semi-transparent animals, without the necessity of removing them from the field of the microscope, that the compressorium is most useful. Wherever the first and simplest of the above methods can be had-recourse-to, it is the preferable one; since the object, when on a glass slide, can be subjected to the Achromatic Condenser, Polariscopes, Oblique Illumination, &c., with far more convenience than when removed to a plane above the stage, as it must be when the aquatic box is used.—Whether the object be submitted to examination on a slip of glass, or in the aquatic box or compressorium, it must be first brought approximately into position, and supported there, just as if it were in a mounted slide. The precise mode of effecting this will differ, according to the particular

plan of the instrument employed; thus in some, it is only the ledge itself that slides along the stage; in others, it is a carriage of some kind, whereon the object-slide rests; in others, again, it is the entire platform itself that moves upon a fixed plate beneath.

86. Having guided his object, as nearly as he can do by the unassisted eye, into its proper place, the Microscopist then brings his light (whether natural or artificial) to bear upon it, by turning the mirror in such a direction as to reflect upon its under surface the rays which are received by itself from the sky or the lamp. The *concave* mirror is that which should always be first employed, the *plane* being reserved for special purposes; and it should bring the rays to convergence in or near the plane in which the object lies (Fig. 54). The

FIG. 54.

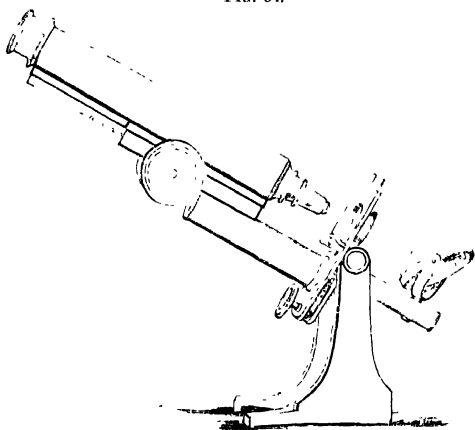

Arrangement of Microscope for Transparent Objects.

distance at which it should be ordinarily set beneath the stage, is that at which it brings parallel rays to a focus; but this distance should be capable of elongation, by the lengthening of the stem to which the mirror is attached; since the rays diverging from a lamp at a short distance, are not so soon brought to a focus. The correct focal adjustment of the mirror may be judged-of, by its formation of images of

window-bars, chimneys, &c., upon any semi-transparent medium placed in the plane of the object. It is only, however, when small objects are being viewed under high magnifying powers, that such a concentration of the light reflected by the mirror is either necessary or desirable; for, with large objects, seen under low powers, the field would not in this mode be equably illuminated. The diffusion of the light over a larger area may be secured, either by shifting the mirror so much above or so much below its previous position, that the pencil will fall upon the object whilst still converging or after it has met and diverged; or, on the other hand, by the interposition of a plate of ground-glass in the course of the converging pencil,—this last method, which is peculiarly appropriate to lamp-light, being very easily had-recourse-to, if the diaphragm-plate, as formerly recommended (§ 55), have had its largest aperture filled with such a diffusive medium.—The eye being now applied to the Eye-piece, and the body being ‘focussed,’ the object is to be brought into the exact position required, by the use of the traversing-movement, if the stage be provided with it; if not, by the use of the two hands, one moving the object-slide from side to side, the other pushing the ledge, fork, or holder that carries it, either forwards or backwards, as may be required. It is always to be remembered, in making such adjustments by the direct use of the hands, that, owing to the inverting action of the microscope, the motion to be given to the object, whether lateral or vertical, must be precisely opposed to that which its image *seems* to require, save when the Erector (§ 44) is employed. When the object has been thus brought fully into view, the Mirror may require a more accurate adjustment. What should be aimed-at, is the diffusion of a clear and equable light over the entire field; and the observer should not be satisfied, until he has attained this object. If the field should be darker on one side than on the other, the mirror should be slightly turned in such a direction as to throw more light upon that side; perhaps in so doing, the light may be withdrawn from some part previously illuminated; and it may thus be found that the pencil is not large enough to light-up the entire field. This may be owing to one of three causes: either the cone of rays may be received by the object too near to its focal apex, the remedy for which lies in an alteration in the distance of the mirror from the stage; or, from the very oblique position of the mirror, the cone is too much narrowed across one of its diameters, and the remedy must be sought in a change in

the position either of the microscope or of the lamp, so that the face of the mirror may not be turned so much away from the axis of vision; or, again, from the centre of the mirror being out of the optical axis of the instrument, the illuminating cone is projected obliquely, an error which can be rectified without the least difficulty. If the cone of rays should come to a focus in the object, the field is not unlikely to be crossed by the images of window-bars or chimneys, or the form of the lamp-flame may be distinguished upon it; the former must be got-rid-of by a slight change in the inclination of the mirror; and if the latter cannot be dissipated in the same way, the lamp should be brought a little nearer.

87. The equable illumination of the entire field having been thus obtained, the *quantity* of light to be admitted should be regulated by the Diaphragm-plate (§ 55). This must depend very much upon the nature of the object, and upon the intensity of the light. Generally speaking, the more transparent the object, the less light does it need for its most perfect display; and its most delicate markings are frequently only made visible, when the major part of the cone of rays has been cut-off. Thus the movement of the *cilia*,—those minute vibratile filaments, with which almost every Animal is provided in some part of its organism, and which many of the humbler Plants also possess,—can only be discerned in many instances, when the light is admitted through the smallest aperture. On the other hand, the less transparent objects usually require the stronger illumination which is afforded by a wider cone of rays; and there are some (such as semi-transparent sections of fossil teeth) which, even when viewed with low powers, are better seen with the intenser light afforded by the Achromatic Condenser.—In every case in which the object presents any considerable obstruction to the passage of the rays through it, great care should be taken to protect it entirely from *incident* light; since this extremely weakens the effect of that which is received into the microscope by transmission. It is by daylight that this interference is most likely to occur: since, if the precautions already given (§ 76) respecting the use of lamplight be observed, no great amount of light *can* fall upon the upper surface of the object. The observer will be warned that such an effect is being produced, by perceiving that there is a want, not only of brightness, but of clearness, in the image; the field being veiled, as it were, by a kind of thin vapour; and he may at once satisfy himself of the cause, by interposing his hand between the stage and the source of

light, when the immediate increase of brilliancy and of distinctness will reveal to him the occasion of the previous deficiency in both. Nothing more is necessary for its permanent avoidance, than the interposition of an opaque screen (blackened on the side towards the stage) between the window and the object; care being of course taken, that the screen does not interfere with the passage of light to the mirror. Such a screen may be easily shaped and adapted either to be carried by the stage itself, or by the stand for the condenser; but it is seldom employed by Microscopists, as it interferes with access to the left side of the stage, and the interposition of the hand, so often as it may be needed, is more frequently had-recourse-to in preference, as the more convenient expedient. The young Microscopist who may be examining transparent objects by daylight, is recommended never to omit ascertaining, whether the view which he may obtain of them, is in any degree thus marred by incident light.

88. Although the illumination afforded by the Mirror alone is quite adequate for a very large proportion of the purposes for which the Microscope may be profitably employed (nothing else having been used by many of those who have made most valuable contributions to Science by means of this instrument), yet, when high magnifying powers are employed, and sometimes even when but a very moderate amplification is needed, great advantage is gained from the use of the *Achromatic Condenser*. The various modes in which this may be constructed, and may be fitted to the Microscope, have been already described (§ 56); we have now to speak of the manner of using it. The lenses with which the Condenser is provided should be made to separate from each other, in such a manner that two or three distinct powers should be afforded; the complete combination should be used with objectives of 1.5th inch focus or less; the front lens should be removed with objectives of from half to a quarter of an inch focus; and the second lens may be removed, so that the back lens will be alone employed, when it is desired to use the condenser with objectives of less than half an inch focus. It is of the greatest importance that the Condenser should be accurately adjusted, both as to the coincidence of its optical axis with that of the Microscope itself, and as to its focal distance from the object. The *centering* may be most readily accomplished, by so adjusting the distance of the condenser from the stage (by the rack-and-pinion action, or the sliding movement, with which it

is always provided), that a sharp circle of light shall be thrown on any semi-transparent medium laid upon it; then, on this being viewed through the Microscope with an objective of sufficiently low power to take-in the whole of it, if this circle be not found to be concentric with the field of view, the axis of the condenser must be altered by means of the milled-head tangent-screws with which it is provided. The *focal adjustment*, on the other hand, must be made under the objective which is to be employed in the examination of the object, by turning the mirror in such a manner as to throw upon the visual image of the object (previously brought into the focus of the Microscope) an image of a chimney or window-bar, if daylight be employed, or of the top, bottom, or edge of the lamp-flame, if lamp-light be in use; such a vertical movement should be given to the condenser, as may render the view of this as distinct as possible; and the direction of the mirror should then be sufficiently changed to displace these images, and to substitute for them the clearest light that can be obtained. It will generally be found, however, that although such an exact focussing gives the most perfect results by daylight, yet that by lamp-light the best illumination is obtained, when the condenser is removed to a somewhat greater distance from the object, than that at which it gives a distinct image of the lamp. In every case, indeed, in which it is desired to ascertain the effect of *variety* in the method of illumination, the effects of alterations in the distance of the condenser from the object should be tried; as it will often happen that delicate markings become visible when the condenser is a little *out of* focus, which cannot be distinguished when it is precisely *in* focus.—The diaphragm-plate with which all the best forms of Achromatic Condenser are now furnished, enables the observer not only to vary the angle of his illuminating pencils through a range of from 20° to 80° , but also to stop-off the central portion of the pencil, so as to allow only its most oblique rays to pass, and the contrast presented by the aspect of many objects, according as the size and form of the aperture in the diaphragm plate limits the rays transmitted by the condenser to those of the central or those of the peripheral portion of the pencil, is often so marked, as to show beyond question the great importance of this mode of varying the illumination.—When the Condenser is employed, the *plane* Mirror may often be substituted with advantage for the concave; the chief effect of this exchange being to diminish the quantity of light, without altering the

angle of the illuminating pencil. It must be borne in mind, in making such an alteration, that the plane mirror reflects parallel or (if from a lamp) diverging rays, instead of the converging rays reflected by the concave mirror; so that the focus of the condenser is likely to require re-adjustment. For objects of great delicacy and transparency, the 'white-cloud' illumination (§ 58) may be had-recourse-to with advantage; or, if it be desired that the illuminating pencil should be free from the error imparted by the double reflection of the mirror, the mirror may be turned aside, and in its stead the lamp (if the observation be made by artificial light) may be placed in the axis of the microscope; or the mirror may be replaced by 'Dujardin's prism' (§ 57), which will be equally available either by daylight or by lamp-light.

89. Should it be desired, however, to try the effect of very oblique light upon an object, the Achromatic Condenser must be removed (unless, as in Mr. Sollitt's arrangement, § 130, it be so constructed as to be capable of inclination to the axis of the Microscope), and other means must be employed. The simplest method, where the mirror is mounted on an 'arm' (Fig. 29), is to turn it to one side, so as to reflect the rays at a considerable angle; and where this cannot be done, nearly the same effect is produced by placing the lamp in the direction from which it is desired that the oblique rays should proceed, and interposing an ordinary condensing lens between it and the object. Or, if the Microscopist be provided with the means of mounting a 'Dujardin's prism' on a separate stand, he may place it in such a position as to reflect light from any point required: and he may concentrate that light by an ordinary condenser. The possession of Amici's prism, however (which serves both as mirror and condenser, § 60), will save the necessity of any other provision of this kind.—It is when objects are thus illuminated by oblique light, and when their markings are of such a kind as to be *best* or to be *only* shown by light falling upon them in one particular direction, that we derive the greatest advantage from the power of giving a rotatory movement either to the object or to the illuminating apparatus. Thus suppose that an object be marked by longitudinal striae, too faint to be seen by ordinary direct light; the oblique light most fitted to bring them into view, will be that proceeding in either of the directions c or d; that which falls upon it in the directions A and B, tending to

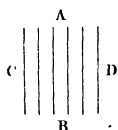

obscure the striae rather than to disclose them. But, moreover, if the striae should be due to furrows or prominences which have one side inclined and the other side abrupt, they will not be brought into view indifferently by light from *c* or from *d*, but will be shown best by that which makes the strongest shadow: hence if there be a projecting ridge, with an abrupt side looking towards *c*, it will be best seen by light from *d*; whilst if there be a furrow with a steep bank on the side of *c*, it will be by light from that side that it will be best displayed. But it is not at all unfrequent for the longitudinal striae to be crossed by others; and these transverse striae will usually be best seen by the light that is least favourable for the longitudinal; so that, in order to bring them into distinct view, either the illuminating pencil or the object must be moved a quarter round. The revolving action with which the stage of Mr. Ross's Microscope is provided (§ 37), enables this movement to be given to the object without any displacement of its image, which of course executes, to the eye of the observer, a rotation in the opposite direction. In other microscopes, however, it is difficult to give a rotation to the object, by causing the object-platform to turn upon its axis, without throwing the object out of the field (§ 38); though this may be accomplished, by such an adjustment of the traversing movement, as shall bring the centre of the tube on which that platform turns-round, into the visual axis of the microscope—or, if this adjustment cannot be conveniently made in the first instance, by keeping the right hand constantly in action upon the milled-heads of the stage-movement, whilst the left hand rotates the object-platform, so as, by means of the former, to correct the displacement of the object occasioned by the latter. It may be sufficient, however, to examine the object in several different positions, so that the appearances it presents in each may be compared, without thus watching the transition from one to the other.

90. There are many kinds of transparent objects, especially such as either consist of thin plates, disks, or spicules of siliceous or calcareous matter, or contain such bodies, which are peculiarly well seen under the *black-ground* illumination (§§ 61, 62); for not only does the brilliant luminosity which they then present, contrasting remarkably well with the dark ground behind them, show their forms to extraordinary advantage; but this mode of illumination imparts to them an appearance of solidity, which they do not exhibit by ordinary transmitted light (§ 62); and it also frequently brings-out

surface-markings, which are not otherwise distinguishable. Hence, when any object is under examination, that can be supposed to be a good subject for this method, the trial of it should never be omitted. For the low powers, the use of the 'spotted lens' will be found sufficiently satisfactory; for the higher, the paraboloid should be employed (§ 61).—Similar general remarks may be made, respecting the examination of objects by *polarized* light. Some of the most striking effects of this kind of illumination, are produced upon bodies whose particles have a crystalline aggregation; and hence it may often be employed with great advantage to bring such bodies into view, when they would not otherwise be distinguished; thus, for example, the *raphides* of Plants are much more clearly made-out by its means, in the midst of the vegetable tissues, than they can be by any other. But the peculiar effects of polarized light are also exerted upon a great number of other organized substances, both Animal and Vegetable; and it often reveals differences in the arrangement or in the relative density of their component particles, the existence of which would not otherwise have been suspected; hence, the Microscopist will do well to have recourse to it, whenever he may have the least suspicion that its use can give him an additional power of discrimination.

91. *Arrangement for Opaque Objects.*—Although a large proportion of the objects best suited for Microscopic examination are either in themselves sufficiently transparent to admit of being viewed by light *transmitted* through them, or may be made so by appropriate means, and although that method (where it *can* be adopted) is generally the one best fitted for the elucidation of the details of their structure, yet there are many objects of the most interesting character, the opacity of which entirely forbids the use of this method, and of which, therefore, the *surfaces* only can be viewed, by means of the *incident* rays which they *reflect*. These are, for the most part, objects of comparatively large dimensions, for which a low magnifying power suffices; and it is specially important, in the examination of such objects, not to use a lens of shorter focus than is absolutely necessary for discerning the details of the structure; since, the longer the focus of the objective employed, the less is the indistinctness produced by inequalities of the surface, and the larger, too, may be its aperture, so as to admit a greater quantity of light, to the great improvement of the brightness of the image. It is surprising how little attention has been given by Opticians to

the construction of objectives suitable for this purpose. In their zeal for the improvement of the higher powers of the Microscope, they have thought comparatively little of the lower; and in Continental Microscopes, it is rare to meet with an objective which will give even a tolerable view of a large opaque object. The Author, indeed, well remembers the time, when it was not thought worth-while, even by English Opticians, to construct Achromatic object-glasses of less than an inch focus; and the production of objectives of $1\frac{1}{2}$ in. and 2 in. focus has been chiefly called-for, in consequence of their value in displaying anatomical preparations in which the blood-vessels have been injected with colouring-matter. The view which is afforded of large opaque objects, however, by a Compound microscope, furnished with even an imperfectly-corrected Achromatic object-glass, giving a magnifying power of 20 or 25 diameters, is so greatly preferable to that which is given by any Simple microscope, that no instrument that is intended for general research should be unfurnished with such a power. It is especially required in Microscopes that are to be used for Educational purposes; since it is most important that the young should be trained in a knowledge of the wonders and beauties of the familiar objects around them; and an objective of low power and wide aperture, adapted to the examination of a large surface at once, affords a means of displaying these, such as can be afforded in no other way, save by the use of the Erector and draw-tube (§ 44). A microscope furnished with these appendages, need not be supplied with an objective of longer focus than 1 in. or 8-10ths in.; but the Author would strongly recommend to such as do not possess them, that they should give to a 'dividing' $1\frac{1}{2}$ in. or 2 in. (in which the front-lens is removable, and is replaced by a perforated cap that limits the aperture of the back-lens, which is then employed by itself, having a focus of about 3 in.) a preference over such as do not thus supply the extremely low power which he recommends*.

92. The mode of bringing opaque objects under view, will differ according to their 'mounting,' and to the manner in

* A single pair (flint and crown) of about 2 in. focus, was constructed at the Author's request, some years since, by Messrs. Smith and Beck, for the special purpose of exhibiting injected preparations, and other opaque objects, and its performance has been so satisfactory to him, that he was induced to urge upon the Microscopic Committee appointed by the Society of Arts, that the Educational Microscope for which they invited competition (§ 31), should be furnished with such a power. This recommendation having been adopted, the instrument selected has been specially fitted for the class of objects above alluded-to

which it is desired to illuminate them. If the object be mounted in a 'slide' of glass or wood, upon a large opaque surface, the slide must be laid on the stage in the usual manner, and the object brought as nearly as possible into position by the eye alone (§ 81). If it be not so mounted, it may be simply laid upon the glass stage-plate, resting against its ledge; and the diaphragm-plate must then be so turned, as to afford it a black back-ground. For all ordinary purposes, a plano- or double-convex lens, of about $1\frac{1}{2}$ inch diameter, and 2 inches focus, either mounted upon a separate stand (as in Fig. 45), or so attached by a jointed support to the Microscope itself as to admit of being placed in any required

FIG. 52.

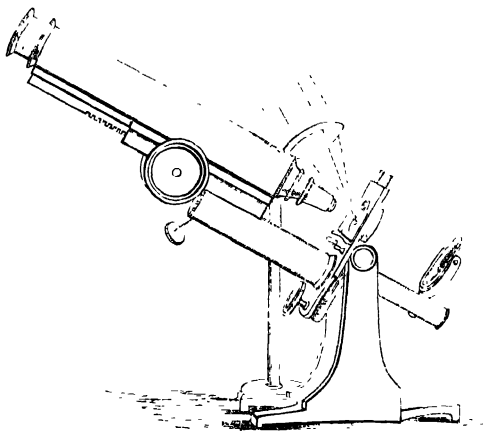

Arrangement of Microscope for Opaque Objects.

position, will answer extremely well as a Condenser.--If Day light be employed, the microscope should be so placed that the strongest light may fall obliquely upon the stage, and preferably from the left hand side; there will then be no difficulty in so disposing this condenser, as to afford an illumination sufficient for almost any kind of object, provided the quality of the light itself be good. Direct sunlight cannot be here employed, without the production of an injurious glare, and the risk of burning the object; but the sunlight reflected from a

bright cloud is the best light possible. The condenser should always be placed at right angles to the direction of the illuminating rays, and at a distance from the object which will be determined by the size of the surface to be illuminated and by the kind of light required. If the magnifying power employed be high, and the field of view be consequently limited, it will be desirable so to adjust the lens, as to bring the cone of rays to a point upon the part of the object under examination; and this adjustment can only be rightly made whilst the object is kept in view under the microscope, the condenser being moved in various modes, until that position has been found for it in which it gives the best light. If, on the other hand, the power be low, and it be desired to spread the light equably over a large field, the condenser should be placed either within or beyond its focal distance; and here, too, the best position will be ascertained by trial. It will often be desirable also, to vary both the obliquity of the light, and the direction in which it falls upon the object; the aspect of which is greatly affected by the manner in which the shadows are projected upon its surface, and in which the lights are reflected from the various points of it. There are many objects, indeed, distinguished by their striking appearance when the light falls upon them on one side, which are entirely destitute both of brilliancy of colour and of sharpness of outline, when illuminated from the opposite side. Hence it is always desirable to try the effect of changing the position of the object; which, if it be 'mounted,' may be first shifted by merely reversing the place of the two ends of the slide, and then, if this be not satisfactory, may be more completely as well as more gradually altered, by making the object-plate itself revolve, where the stage is fitted with such a movement. If, however, the object be not mounted, but be simply resting on the stage-plate, it may be readily shifted by hand. With regard to the obliquity of the illuminating rays, it is well to remark, that if the object be 'mounted' under a glass cover, and the incident rays fall at too great an angle with the perpendicular, a large proportion of them will be reflected, and the brilliancy of the object will be greatly impaired.

93. The same general arrangement must be made, when Artificial light is used for the illumination of opaque objects; the lamp being placed in such a position in regard to the stage, that its rays may fall in the direction indicated in Fig. 55; and these rays being collected and concentrated by the condenser, as already directed. As the rays proceeding from a lamp

within a short distance are already diverging, they will not be brought by the condenser to such speedy convergence, as are the parallel rays of daylight; and it must, therefore, be further removed from the object, to produce the same effect. By modifying the distance of the condenser from the lamp and from the object respectively, the cone of rays may be brought nearly to a focus, or it may be spread almost equably over a large surface, as may be desired. In the illumination of opaque objects, the inferiority of artificial to solar light is not so perceptible as in the case of transparent objects; and the former has the advantage of being more easily concentrated to the precise degree, and of being more readily made to fall in the precise direction, that may be found most advantageous. Moreover, the contrast of light and shadow will be more strongly marked, when no light falls upon the object except that proceeding from the lamp used for its illumination, than it can be when the shadows are partially lightened by the rays which fall upon the object from every quarter, as must be the case if it be viewed by daylight. If the ordinary condensing-lens do not afford a sufficient illumination, the large 'bull's-eye' condenser (§ 64) may be employed; its convex side being turned towards the lamp, when it is desired to bring its rays into the most complete convergence. And, if a still more concentrated light be required for the illumination of a small object under a high power, the small condenser may be so placed as to receive the cone where it is reduced to its own size; since, by its means, the rays may be brought to a more exact convergence than they can be by the bull's-eye alone. In this manner, very minute bodies may be viewed as opaque objects under a tolerably-high magnifying power; provided that the brasswork of the extremities of the objectives be so bevelled-off, as to allow the illuminating cone to have access to the object.*—No method of illuminating large opaque objects by lamp-light is more effective, than the reflection of light from a concave speculum placed near the side of the object (§ 65); this not only affords a brilliant light, which may be equably spread over as large a surface as may be required, but may, by the mode in which it is jointed to its supports, be

* Since the introduction of the Parabolic illuminator, the occasions on which advantageous recourse can be had to the examination of minute objects with high powers by incident light, have become much less numerous; since these objects are for the most part sufficiently transparent to admit of being illuminated by that instrument; and when they are so, the view of them which it affords is generally much superior to any that can be gained by the method of illumination described above

made to throw its rays upon the object at a great variety of angles, without the necessity of moving the lamp, whereby the direction in which the best illumination can be gained, is readily ascertained. If a more intense light and a greater concentration be required, than the speculum will afford by reflecting the diverging rays of the lamp, these may be rendered parallel or slightly convergent by the interposition of the bull's-eye condenser, which, for such a purpose, must have its *plane* side turned towards the lamp. This speculum cannot be so advantageously used by daylight, the ordinary condensing-lens being then decidedly preferable.

94. If the object which it is desired to examine be of small size, and of a shape and character that render it unsuitable to be laid upon the glass stage-plate, or to be turned over so as to bring each side in turn into the most advantageous position,—as is the case, for example, with the capsules of Mosses, the mouths of which cannot be conveniently brought into view in this mode,—it may be grasped in the stage-forceps (§ 66), which afford great facility for this kind of manipulation; or, if it be too minute or delicate to be thus held, it may be taken-up upon the head of a small pin, by moistening this with saliva or with a little thin gum-water; and the pin may then be either held in the stage-forceps, or may be run into the cork at its opposite extremity. By careful manipulation, every part of such an object may be brought under view successively, and may be exposed to every variety of illumination. It is in viewing objects supported in this mode, that the utility of the Lieberkuhn (§ 65) is chiefly felt; for, as the stage-forceps needs to be shifted into different positions, so that the object is sometimes raised above and sometimes depressed below the level of the stage, in order to present it under a different aspect, the side-illumination, whatever be its source, needs to be newly adjusted with each change in the position of the object; whilst the Lieberkuhn adjusts itself, so to speak, when the object is brought into focus. If the mirror be so mounted that it can be turned considerably out of the axis of the microscope, and the aperture of the stage be sufficiently large, a light of considerable obliquity may be reflected from the Lieberkuhn; thus enabling it to afford a kind of illumination, which, as already remarked, is usually much more valuable than that produced by the nearly perpendicular rays sent down by it on the object, when the mirror is placed in the axis. Whenever the Lieberkuhn is employed, care must be taken that the direct light from the

mirror be entirely stopped-out by the interposition of a 'dark well' or of a black disk, of such a size as to *fill* the field given by the particular objective employed, but not to pass much beyond it.—An ingenious combination of a *hemispherical* Lieberkuhn with the Paraboloid (§ 61) has been devised by Mr. Wenham, for the illumination of minute opaque objects by very oblique rays,* and Mr. C. Brooke has attached a small *plane* speculum to objectives of 1-8th and 1-12th inch focus (which cannot be otherwise advantageously employed with that illuminator), in such a manner that its surface is level with, or very little below, that of the outer lens, so as to reflect downwards upon the object those extreme pencils of rays which pass-by the aperture of the object-glass. In either case, an oblique illumination from one side only may be obtained, by shutting-off either half of the lower aperture of the paraboloid. These contrivances for the examination of minute objects with high powers by incident light, have scarcely yet received the attention they deserve.

95. *Errors of Interpretation.*—The correctness of the conclusions which the Microscopist will draw, regarding the nature of any object, from the visual appearances which it presents to him, when examined in the various modes now specified, will necessarily depend in great degree upon his previous experience in microscopic observation, and upon his knowledge of the class of bodies to which the particular specimen may belong. Not only are observations of *any* kind liable, as already remarked (Introduction, pp. 8-10), to certain fallacies arising out of the previous notions which the observer may entertain, in regard to the constitution of the objects or the nature of the actions to which his attention is directed; but even the most practised observer is apt to take no note of such phenomena as his mind is not prepared to appreciate. Thus, for example, it cannot be doubted that many Physiologists must have seen those appearances in thin slices of Cartilage, which are now interpreted as denoting its *cellular* organization, without in the least degree suspecting their real import, which Schwann was the first to deduce from the study of the development of that tissue; it was not known before his time, "what cells mean" in Animal organization; and the retinal pictures which now suggest the idea of them to the mind of even the tyro in the study of Histology (p 26), passed almost entirely unnoticed by keen-sighted and

* "Quart. Journ. of Microsc. Science," vol. ii. p. 155.

intelligent Microscopists previously to 1839. Errors and imperfections of this kind can only be corrected, it is obvious, by general advance in scientific knowledge; but the history of them affords a useful warning against hasty conclusions drawn from a too-cursory examination. If the history of almost *any* scientific investigation were fully made known, it would generally appear, that the stability and completeness of the conclusions finally arrived-at, had only been attained after many modifications, or even entire alterations, of doctrine. And it is, therefore, of such great importance to the correctness of our conclusions, as to be almost essential, that they should not be finally formed and announced, until they have been tested in every conceivable mode. It is due to Science, that it should be burdened with as few false facts and false doctrines as possible. It is due to other truth-seekers, that they should not be misled, to the great waste of *their* time and pains, by *our* errors. And it is due to ourselves, that we should not commit our reputation to the chance of impairment, by the premature formation and publication of conclusions, which may be at once reversed by other observers better informed than ourselves, or may be proved to be fallacious at some future time, perhaps even by our own more extended and careful researches. The *suspension of the judgment, whenever there seems room for doubt*, is a lesson inculcated by all those Philosophers who have gained the highest repute for practical wisdom; and it is one which the Microscopist cannot too soon learn, or too constantly practise.

96. Besides these general warnings, however, certain special cautions should be given to the young Microscopist, with regard to errors into which he is liable to be led, by the misinterpretation of appearances peculiar to objects thus viewed, even when the very best instruments are employed.— Thus the sharpness of the outline of any transparent object is impaired by a change in the course of the rays that merely *pass-by* it, which is termed *Inflection* or *Diffraction*. If any opaque object be held in the course of a cone of rays diverging from a focus, the shadow which it will form upon a screen held to receive it, will not possess a well-defined *edge*, but will have as its boundary a shaded *band*, gradually increasing in brightness from the part of the screen on which the shadow is most intense, to that on which the illumination is most complete. If the light be homogeneous in its quality, the shaded band will possess no colours of its own; but if the light be decomposable, like the ordinary solar beam, the band will

exhibit prismatic fringes.* It is obvious that such a diffraction must exist in the rays transmitted through the substance, as well as along the edges, of transparent objects; and that it must interfere with the perfect distinctness, not merely of their outlines, but of their images, the various markings of which are *shadows* of portions that afford obstacles, more or less complete, to the perfectly-free transmission of the rays. There are many objects of great delicacy, in which the 'diffraction-band' is liable to be mistaken for the indication of an actual substance; on the other hand, the presence of an actual substance of extreme transparency, may sometimes be doubted or denied, through its being erroneously attributed to the 'diffraction-band.† No rules can be given for the avoidance of such errors, since they can only be escaped by the discriminative power which education and habit confer. The practised Microscopist, indeed, almost instinctively makes the requisite allowance for diffraction; and seldom finds himself embarrassed by it, in the interpretation of the visual appearances which he obtains through a good instrument.—Besides this unavoidable result of the inflection of the rays of light, there is a peculiar phenomenon attendant upon oblique illumination at certain angles in one direction; which consists in the production of a double image, or a kind of overlying shadow, sometimes presenting markings equally distinct with those of the object itself. This image, which is not unlike the secondary spectrum formed by reflection from the outer surface of a silvered-glass mirror, has been called the 'diffracting spectrum;' but its origin does not really lie in the diffraction of the luminous rays, since on the one hand it cannot be explained according to the laws of diffraction, and on the other it may be traced to an entirely different cause. An object thus illuminated is seen by two different sets of rays; those, namely, of *transmitted* light, which pass through it obliquely from the source of the illumination to the opposite

* This phenomenon is explained on the Undulatory Theory of light, by the disturbance which takes place in the onward propagation of waves, when subsidiary centres of undulation are developed by the impact of the principal undulations on obstacles in their course; the chromatic dispersion being due to the inequality in the lengths of the undulations proper to the severally-coloured rays.

† Thus the account given by Prof. Sharpey and the Author, of the structure of Muscular Fibre (Chap. XVIII.), has been called in question by observers who had not seen their preparations, on the ground that the 'diffraction-band' had not been allowed-for. To whatever the appearance in question (Fig. 326) may be due, there cannot be the slightest question that it does *not* arise from diffraction.

side of the object-glass; and those of *radiated* light, which, being intercepted by the object, are given-off from it again in all directions. (The latter alone are the rays whereby the images are formed in any kind of 'black-ground' illumination, §§ 61, 62). Two different images will be formed, when the illuminating pencil is very oblique, and the angular aperture of the object-glass is wide; one of them by the light transmitted to one extreme of its aperture, the other by the light radiated to its general surface; and one or the other of these images may be stopped-out, by covering that portion of the lens which receives, or that which does not receive, the transmitted pencil. This 'diffracting spectrum' may be produced at pleasure, in an object illuminated by direct light and seen with a large aperture, by holding a needle or a horsehair before the front lens, so as to split the aperture into two parts.

97. Errors of interpretation arising from the imperfection of the Focal adjustment, are not at all uncommon amongst young Microscopists. With lenses of high power, and especially with those of large angular aperture, it very seldom happens that all the parts of an object, however small and flat it may be, can be in focus together; and hence the focal adjustment being exactly made for one part, everything that is not in exact focus is not only more or less indistinct, but is often wrongly represented. The indistinctness of outline will sometimes present the appearance of a pellucid border, which, like the diffraction-band, may be mistaken for actual substance. But the most common error is that which is produced by the reversal of the lights and shadows, resulting from the refractive powers of the object itself; thus, the bi-concavity of the blood-disks of Human (and other Mammalian) blood, occasions their centres to appear *dark*, when in the focus of the Microscope, through the dispersion of the light which it occasions; but when they are brought a little within the focus, by a slight approximation of the object-glass, the centres appear brighter than the peripheral parts of the disks (Fig. 315). The same reversal presents itself in the case of the markings of the Diatomacæ; for these, when the surface is exactly in focus, are seen as light hexagonal spaces, separated by dark partitions; and yet, when the surface is slightly beyond the focus, the hexagonal areas are dark, and the intervening partitions light (Fig. 80). The best means of avoiding errors of interpretation arising from this source, lies in the employment of the *lowest* powers with which the particular structures can be

distinguished; since, if the different parts of the surface and margin of the object can be simultaneously brought so nearly into focus, that a distinct view may be gained of all of them at once, no false appearances will be produced, and everything will be seen in its *real* aspect.

98. A very important and very frequent source of error, which sometimes operates even on experienced Microscopists, lies in the refractive influence exerted by certain peculiarities in the form or constitution of objects, upon the rays of light transmitted through them; this influence being of a nature to give rise to appearances in the image, which suggest to the observer an idea of their cause that may be altogether different from the reality. A very characteristic illustration of the fallacy resulting from external configuration, is furnished by the notion which long prevailed amongst Microscopic observers, and which still lingers in the public mind, of the *tubular* structure of the Human hair. This notion has no other foundation, than the existence of a bright band down the axis of the hair, which is due to the convergency of the rays of light occasioned by the *convexity* of its surface, and which is equally shown by any other transparent cylinder; and it is unmistakably disproved by the appearances presented by thin transverse sections of Hair, which show that it is not only filled up to its centre with a medullary substance, but that its centre is sometimes even darker than the surrounding part (Fig. 311). Of the fallacy which may arise from diversities in the refractive power of the internal parts of an object, we have an equally 'pregnant instance' in the misinterpretation of the nature of the *lacunæ* and *canaliculi* of Bone (Fig. 300), which were long supposed to be solid corpuscles with radiating filaments of peculiar opacity, instead of being, as is now universally admitted, minute chambers with diverging passages, excavated in the solid osseous substance. For just as the convexity of its surfaces will cause a transparent cylinder to show a bright axial band, so will the concavity of the internal surfaces of the cavities or tubes hollowed-out in the midst of highly-refracting substances, occasion a divergence of the rays passing through them, and consequently render them so dark that they are easily mistaken for opaque solids. That such is the case with the so-called 'bone-corpuscles,' is shown by the effects of the infiltration of Canada-balsam through the osseous substance; for when this fills-up the excavations,—being nearly of the same refractive power with the bone itself, and being also quite transparent, and (in thin laminae)

quite colourless,—it obliterates them altogether. So, again, if a person who is unaccustomed to the use of the microscope should chance to have his attention directed to a preparation mounted in liquid or in balsam, that might chance to contain *air-bubbles*, he will be almost certain to be so much more strongly impressed by the appearance of these, than by that of the object, that his first remark will be upon the number of strange-looking black rings which he sees, and his first inquiry will be in regard to their meaning.

99. No experienced Microscopist could now be led astray by such obvious fallacies as those alluded-to; but it is necessary to dwell upon them, as warnings to those who have still to go through the same education.—The best method of learning to appreciate the class of appearances in question, is the comparison of the aspect of globules of Oil in water, with that of globules of Water in oil, or of bubbles of Air in water or Canada-balsam. This comparison may be very readily made, by shaking-up some oil with water to which a little gum has been added, so as to form an emulsion; or by simply placing a drop of oil of turpentine and a drop of water together on a slip of glass, laying a thin-glass cover upon them, and then moving the cover several times backwards and forwards upon the slide.* Now when such a mixture is examined with a sufficiently-high magnifying power, all the globules present nearly the same appearance, namely, dark margins with bright centres: but when the test of alteration of the focus is applied to them, the difference is at once revealed; for whilst the globules of Oil surrounded by water become *darker* as the object-glass is *depressed*, and *lighter* as it is *raised*, those of Water surrounded by oil become *more luminous* as the object-glass is *depressed*, and *darker* as it is *raised*. The reason of this lies in the fact, that the high refracting power of the oil causes each of its globules to act like a double-convex lens of very short focus; and as this will bring the rays which pass through it into convergence *above* the globule (i. e., between the globule and the objective), its brightest image is given, when the object-glass is removed somewhat further from it than the exact focal distance of the object. On the other hand, the globule of water in oil, or the minute bubble of air in water or balsam, acts, in virtue of its inferior refractive

* If this latter mode be adopted, it is preferable, as suggested by the authors of the 'Micrographic Dictionary' (Introduction, p. xxxii.), to colour the oil of turpentine with alkanet, or some similar substance, for its more ready distinction.

power, like a double-concave lens; and as the rays of this diverge from a virtual focus *below* the globule (i. e., between the globule and the mirror), the spot of greatest luminosity will be found, by causing the object-glass to approach within the proper focus.—Now in the ‘protoplasm’ of the cells of the lower Plants, and in the ‘sarcode’ of the lower Animals, oil-particles and *vacuoles* (or void spaces) are often interspersed; and present, at first sight, so very striking a resemblance, that the inexperienced observer may well be pardoned for mistaking the ‘vacuoles’ for larger globules of a material more refractive than the gelatinous substance around them. But the difference in the effects of alterations of focus on the two sets of appearances, at once serves to make evident the difference of their causes; and this, moreover, is made obvious by the effect of oblique light, which will cause the strongest shadow to exhibit itself on opposite sides, in the two cases respectively — It will be obvious that minute elevations and depressions of the *surface* of the object will exert an influence upon the course of the rays which it transmits, very similar to that which proceeds from the presence of globular spaces, filled with transparent substances of greater or less refracting power, in its interior; and that the discrimination between the two may be made by the same means. For if the dots appear more luminous as the object-glass is raised, and darker as it is depressed, they may be interpreted as being due to *convexities* upon the surface; but if the contrary is the case, they may be referred to *concavities*.

100. Among the sources of fallacy by which the young Microscopist is liable to be misled, one of the most curious is the *Molecular Movement* which is exhibited by the particles of nearly all bodies that are sufficiently finely divided, when suspended in water or other fluids. This movement was first observed in the fine granular particles, which exist in great abundance in the contents of the pollen-grains of plants (sometimes termed the *fovilla*), and which are set-free by crushing these grains; and it was imagined that they indicated the possession of some special vital endowment by these particles, analogous to that of the spermatozoa of animals. In the year 1827, however, it was announced by Dr. Robert Brown, that numerous other substances, organic and inorganic, when reduced to a state of equally-minute division, exhibit a like movement, so that it cannot be regarded as indicative of any endowment peculiar to the fovilla-granules; and subsequent researches have shown, that there is no known exception to

the rule, that such motion takes place in the particles of *all* substances, though some require to be more finely divided than others, before they will exhibit it. Nothing is better adapted to show it, than a minute portion of gamboge, indigo, or carmine, rubbed-up with water; for the particles of these substances, which are not dissolved, but only suspended, are of sufficiently large size to be easily distinguished with a magnifying power of 250 diameters, and are seen to be in perpetual locomotion. Their movement is chiefly of an oscillatory kind; but they also rotate backwards and forwards upon their axes, and they gradually change their places in the field of view. It may be observed that the movement of the smallest particles is the most energetic, and that the largest are quite motionless, whilst those of intermediate size move, but with comparative inertness. The movement is not due (as some have imagined) to evaporation of the liquid; for it continues, without the least abatement of energy, in a drop of aqueous fluid that is completely surrounded by oil, and is therefore cut-off from all possibility of vaporization; and it has been known to continue for many years, in a small quantity of fluid enclosed between two glasses in an air-tight case. It is, however, greatly accelerated, and rendered more energetic, by Heat; and this seems to show that it is due, either directly to some caloric changes continually taking-place in the fluid, or to some obscure chemical action between the solid particles and the fluid, which is indirectly promoted by heat. It is curious that the closer the conformity between the specific gravity of the solid particles and that of the liquid, the less minute need be that reduction in their size which is a necessary condition of their movement; and it is from this that the substances just named are so favourable for the exhibition of it. On the other hand, the particles of metals, which are from seven to twelve times as heavy as water, require to be reduced to a minuteness many times greater than that of the particles of carmine or gamboge, before they become subject to this curious action.—In any case in which the motions of very minute particles, of whatever kind, are in question, it is necessary to make allowance for this ‘molecular movement;’ and the young Microscopist will therefore do well to familiarize himself with its ordinary characters, by the careful observation of it in such cases as those just named, and in any others in which he may meet with it.

101. *Comparative Values of Object-Glasses; Test Objects.*—
In estimating the comparative values of different object-

glasses, regard must always be had to the *purpose* for which each is designed; since it is impossible to construct a combination, which shall be equally serviceable for *every* requirement. It is commonly assumed, that an Objective which will show certain *test-objects*, must be very superior, for everything else, to a glass which will not show these; but this is known to every practical Microscopist to be a great mistake,—the very qualities which enable it to resolve the more difficult ‘tests’ being incompatible with those which make it most useful in all the ordinary purposes of scientific investigation. Four distinct attributes have to be specially considered, in judging of the character of an object-glass; viz. (1) its *defining power*, or power of giving a clear and distinct image of all well-marked features of an object, especially of its boundaries; (2) its *penetrating power*, or power of enabling the observer to *look into* the structure of objects;* (3) its *resolving power*, by which it enables closely-approximated markings to be distinguished; and (4) the *flatness of the field* which it gives.

1. The ‘Defining power’ of an objective mainly depends upon the *perfection of its corrections*, both for Spherical and for Chromatic aberration (§§ 9-15); and it is an attribute essential to the satisfactory performance of *any* objective, whatever be its other qualities. Good definition may be more easily obtained with lenses of *small* or *moderate*, than with lenses of *large* angular aperture; and in the aim to extend the aperture, the perfection of the definition is not unfrequently impaired. An experienced Microscopist will judge of the defining power of a lens by the quality of the image which it gives of almost any object with which he may be familiar; but there are certain ‘tests,’ to be presently described, which are particularly appropriate for the determination of it. Any imperfection in defining power is exaggerated, as already pointed-out (§§ 22, 80), by the use of ‘deep’ eyepieces; so that, in determining the value of an

* The Author is aware that he is here employing the term ‘Penetration’ in a sense very different from that which it was intended to convey by Dr Goring, who first applied it to designate a certain quality of Microscopic objectives. But he considers that what was termed ‘penetration’ by Dr Goring may be far more appropriately designated as *resolving power*; this term having been long in use to express the parallel attribute of Telescopes, as regards the separation of the diffused luminosity of Nebulae into distinct points of light. The term Penetration, having been thus set-aside, may well be applied (as above) in what seems its *natural* meaning, and the Author (who has long been in the habit of employing it in this sense) may refer to the Report of the Jury of the “Great Exhibition” of 1851, as giving an authoritative sanction to the above use of it.

objective, it is by no means sufficient to estimate its performance under a low eyepiece, an image which appears tolerably clear when moderately magnified, being often found exceedingly deficient in sharpness when more highly amplified. The use of the draw-tube (§ 43) affords an additional means of testing the defining power; but this cannot be fairly had recourse to, unless an alteration be made in the adjustment for the thickness of the glass that covers the object (§ 84), in proportion to the lengthening of the body, and the nearer approximation of the object to the objective which this involves.

II. The 'Penetrating power' of an object-glass (good definition being of course presupposed) mainly depends upon the degree of distinctness with which parts of the object that are *a little out of focus* can be discerned; and this will be found to vary greatly in different objectives, being, within certain limits, in an *inverse* proportion to the extent of the angle of aperture. This is very easily understood on optical principles. The *central* rays of any pencil undergo the *least* refraction or change in their course; the *peripheral* rays, the *most*. The greater the change, the greater is the difference between the amounts of refraction respectively undergone by rays coming-off from points at slightly-different distances; and the greater, when the focal adjustment is correct for *one* of these points, will be the indistinctness of the image of *the other*. Hence an objective of comparatively-limited aperture may enable the observer to gain a view of *the whole* of an object, the several parts of whose structure lie at different distances from it, sufficiently good to afford an adequate idea of the relation of those parts to each other; whilst if the same object be looked-at with an objective of very wide angle of aperture, which only enables what is *precisely* in focus to be seen at all, each part can only be *separately* discerned, and the mutual relations of the whole cannot be brought into view. The want of this 'penetrating power' is a serious drawback in the performance of many objectives, which are distinguished by the possession of other admirable qualities. The possession of a high measure of it is so essential, in the Author's opinion, to the satisfactory performance of those objectives which are to be employed for the *general purposes of scientific investigation*, that he cannot consider its deficiency to be compensated by the possession of any degree of the resolving power, whose use is comparatively limited.

III. The 'Resolving power,' by which very minute markings,

—whether lines, striae, or dots,—are discerned and clearly separated from each other, may be said to stand in direct relation (a perfect definition being pre-supposed) to the extent of its angle of aperture, and consequently to the obliquity of the rays which it can receive from the several points of the surface of the object. This is not so much the case, where the markings depend upon the interposition of opaque or semi-opaque particles in the midst of a transparent substance, so that the lights and shadows of the image represent the absolute degrees of greater or less transparency in its several parts; as it is where, the whole substance being equally transparent, the markings are due to the refracting influence which inequalities of the surface exert upon the course of the rays that pass through it. It may be readily perceived, on a little reflection, that the information given about such inequalities by rays of light transmitted axially through the object, must be very inferior to that which can be gained from rays of light transmitted obliquely; and thus it happens that, as already explained, many such markings are seen by oblique illumination (as, for instance, by the use of the central stop in the condenser, § 56), which could not be seen, under the same object-glass, by light transmitted more nearly in the axis of the microscope. When an object, however, is seen by *transmitted* light, no degree of obliquity in the illuminating rays can be useful, which exceeds that at which the object-glass can receive them: but the illumination of objects which are seen by *radiated* light (§ 62), depends upon these very rays; and thus it is that the ‘black-ground’ illumination by the paraboloid or by any other effective contrivance (§ 61), will often bring surface-markings into view, which cannot be seen by transmitted light. An object-glass of very wide aperture, however, will receive, even with ordinary illumination, so many rays of great obliquity, that the same kind of effect will be produced, as by oblique illumination with an objective of smaller aperture; but when, with such an objective, oblique illumination is used, a greater resolving power is obtained, than any combination of smaller angular aperture *can* possess.—In comparing the resolving power of different object-glasses, it is obviously essential to a correct judgment, that the illumination should be the same; for it will often happen that an observer who knows the ‘points’ of his own instrument, will ‘bring-out’ tests, which another, with object-glasses of much greater capability, does not resolve, simply for want of proper management. Moreover it must be borne in

mind that great resolving power may exist, even though the definition may be far from exact; since the former depends more upon angle of aperture, than upon the perfection of the corrections: and yet there cannot be the slightest question, that, of two objectives of the same focal length, one perfectly corrected up to a moderate angle of aperture, the other with a wider aperture but less perfectly corrected, the former will be the one most suitable to the *general* purposes of the Microscopist.

iv. The 'Flatness of the field' afforded by the object-glass, is a condition of great importance to the advantageous use of the Microscope; since the real extent of the field of view practically depends upon it. Many objectives are so constructed, that, even with a perfectly-flat object, the foci of the central and of the peripheral parts of the field are so different, that when the adjustment is made for one, the other is entirely indistinct. Hence, when the central portion is being looked-at, no more information is gained respecting the peripheral, than if it had been altogether 'stopped-out.' With a really-good object-glass, not only should the image be distinct even to the margin of the field, but the marginal portion should be as free from chromatic fringes or from indistinctness of outline, as the central portion. In many microscopes of inferior construction, the imperfection of the objectives in this respect, is masked by the contraction of the aperture of the diaphragm in the eyepiece (§ 21), which limits the dimensions of the field; and the performance of one objective within this limit may scarcely be distinguishable from that of another, although, if the two were compared under an eyepiece of larger aperture, their difference of excellence would be at once made apparent, by the perfect correctness of one to the margin of the field, and by the entire failure of the other in every part save its centre. In estimating the relative merits of two lenses, therefore, as regards this condition, the comparison should of course be made under the same Eyepiece.

v. It may be safely affirmed, that the *most perfect* Object-glass is that which combines all the preceding attributes, in the highest degree in which they are compatible one with another. But, as has just been shown, two of the most important,—namely, penetrating power and resolving power,—stand in such opposite relations to the angular aperture, that the highest degree of which each is in itself capable, can only be attained by some sacrifice of the other; and therefore of

two objectives which are respectively characterized by the predominance of these opposite qualities, one or the other will be preferred by the Microscopist, according to the particular class of researches which he may be carrying-on; just as a man who is about to purchase a horse, will be guided in his choice by the kind of work for which he destines the animal. Hence it shows, in the Author's estimation, just as limited an appreciation of the practical applications of the instrument, to estimate the merits of an object-glass by its capability of showing certain lined or dotted 'tests,' without any reference to its penetrating or defining power; as it would be if a man should estimate the merits of a horse *merely* by the number of seconds within which he could run a mile, or by the number of pounds he could draw; without any reference, in the first case, either to the weight he could carry, or to the length of time during which he could maintain his speed, and in the second case, either to the rate of his draught, or to his power of continuing the exertion. The greatest capacity for *speed* alone, the power of sustaining it not being required, and burthen being reduced almost to nothing, is that which is sought in the Racer; the greatest *power of steady draught*, the rate of movement being of comparatively little importance, is that which is most valued in the Cart-horse; but for the ordinary carriage-horse or roadster, the highest merit lies in such a *combination* of speed and power with endurance, as cannot co-exist with the greatest perfection of either of the two first.—The Author feels it the more important that he should express himself clearly and strongly on this subject, as there is a great tendency at present, both among amateur Microscopists and among Opticians, to look at the attainment of that 'resolving power' which is given by angular aperture, as the one thing needful; those other attributes which are of far more importance in almost every kind of scientific investigation, being comparatively little thought of; and he therefore ventures here to repeat the remarks, he made upon this subject, in his recent Presidential Address to the Microscopical Society, of the correctness of which he has been since assured, by the approval of many of those who have most successfully employed the Microscope in Physiological investigations.—“The superiority in resolving power possessed by object-glasses of large angular aperture, is obtained at the expense of other advantages. For even granting that there is no sacrifice of that most important element *defining* power (which can only be secured, with a

very wide angle, by the utmost perfection in all the corrections), yet the adequate performance of such a lens can only be secured by the greatest exactness in the adjustments. Only that portion of the object which is *precisely* in focus, can be seen with an approach to distinctness, everything that is in the least degree out of it being imbedded (so to speak) in a thick fog; it is requisite, too, that the adjustment for the thickness of the glass that covers the object, should exactly neutralize the effect of its refraction; and the arrangement of the mirror and condenser must be such as to give to the object the best possible illumination. If there be any failure in these conditions, the performance of a lens of very wide angular aperture is *very much inferior* to that of a lens of moderate aperture; and except in very experienced hands, this is likely to be generally the case. Now to the working Microscopist, unless he be studying the particular classes of objects which expressly require this condition, it is a source of great inconvenience and loss of time to be obliged to be continually making these adjustments; and a lens, which, when adjusted for a thickness of glass of 1-100", will perform without much sensible deterioration with a thickness either of 1-80" or of 1-120", is practically the best for all ordinary purposes. Moreover, a lens of moderate aperture has this very great advantage, that the parts of the object which are less perfectly in focus, can be much better seen; and therefore that the relation of that which is most distinctly discerned, to all the rest of the object, is rendered far more apparent. Let me remind you, further, that almost all the great achievements of Microscopic research have been made by the instrumentality of such objectives as I am recommending. There can be no question about the large proportion of the results which continental microscopists may claim, in nearly all departments of minute anatomical, physiological, botanical, or zoological investigation, since the introduction of this invaluable auxiliary; and it is well known that the great majority of their instruments are of extremely simple construction, and that their objectives are generally of very moderate angular aperture. Moreover, if we look at the date of some of the principal contributions which this country has furnished to the common stock, such as the "Odontography" of Professor Owen, the "Researches into the Structure of Shell" carried-out by Mr. Bowerbank and myself, the "Physiological Anatomy" of Messrs. Todd and Bowman, the first volume of the "Histological Catalogue," by Professor Quekett, and the

“British Desmidæ” of Mr. Ralfs, we find sure reason to conclude that these researches *must* have been made with the instrumentality of lenses, which would in the present day be regarded as of very limited capacity.—I hope that, in these remarks, I shall not be understood as in any way desirous to damp the zeal of those, who are applying themselves to the perfectionizing of achromatic objectives. I regard it as a fortunate thing for the progress of science, that there are individuals whose tastes lead them to the adoption of this pursuit; who stimulate our instrument-makers to go on from one range to another, until they have conquered the difficulties which previously baffled them; and then apply themselves to find out some new tests, which shall offer a fresh difficulty to be overcome. But it is not the *only*, nor can I regard it as the *chief* work of the Microscope, to resolve the markings upon the Diatomacæ, or tests of the like difficulty; and although I *should* consider this as the highest object of ambition to our makers, if the performances of such lenses with test-objects were any fair measure of their general utility, yet as I think that I have demonstrated that the very conditions of their construction render them inferior in this respect for the purposes of ordinary microscopic research, I would much rather hold-out the reward of high appreciation (*we* have no other to give) to him who should produce the *best working microscope*, adapted to all ordinary requirements, *at the lowest cost*. It does not seem to me an unapt simile, to compare the devotees of large angular apertures to the gentlemen of the ‘turf.’ It is, I believe, generally admitted, that the breeding a class of horses distinguished by speed and ‘blood,’ which is kept-up by the devotion of a certain class of our countrymen to the noble sport of racing, is an advantage to almost every breed of horses throughout the country; tending, as it does, to develop and maintain a high standard in these particulars. But no one would ever think of using a race-horse for a roadster or a carriage-horse; knowing well that the very qualities which most distinguish him as a racer, are incompatible with his suitability for ordinary work. And so I think that the ‘breeders’ of first-class Microscopes (if I may so designate them) are doing great service, by showing to what a pitch of perfection certain kinds of excellence may be carried, and by thus improving the standard of ordinary instruments; notwithstanding that, for nearly all working purposes, the latter may be practically superior.”

102. *Test Objects*.—It is usual to judge of the optical per-

fection of a Microscope, by its capacity for exhibiting certain objects, which are regarded as *tests* of the merits of its object-glasses; these tests being of various degrees of difficulty; and that being accounted the best instrument, which shows the most difficult of such tests. Now it must be borne in mind, that only *two* out of the four qualities which have been just enumerated,—namely, *defining* power, and *resolving* power,—can be estimated by any of these tests; and the greater number of them, being objects whose surface is marked by lines, striae, or dots, are tests of *resolving* power, and thus of angular aperture only. Hence, as already shown, an objective may show very difficult *test-objects*, and yet may be very unfit for ordinary use. Moreover, these test-objects are only suitable to object-glasses of very short focus and high magnifying power; whereas the greater part of the real *work* of the Microscope is done with objectives of comparatively low power; and the enlargement of the angular aperture, which enables even these to resolve (under deep eyepieces) many objects which were formerly considered adequate tests for higher powers, is by no means an unmixed good. In estimating the value of an object-glass, it should always be considered for what purpose it is intended; and its merits should be judged-of according to the degree in which it fulfils that purpose. We shall therefore consider, what are the attributes proper to the several ‘powers’ of object-glasses,—*low*, *medium*, and *high*;—and what are the objects by its mode of exhibiting which, it may be fairly judged.

1 By object-glasses of *low* power, we may understand any whose focal length is *greater than half-an-inch*. The ‘powers’ usually made in this country are of 2 in. or $1\frac{1}{2}$ in. focus (these being sometimes made to divide, so as to leave a power of about 3 in. focus), 1 in., and 8-10ths or 2-3rds in.; and they give a range of amplification of from 12 to 60 diameters with the shallower eye-piece, and of from 18 to 90 diameters with the deeper. These are the objectives which are most used in the examination of opaque objects, and of transparent objects of large size and of comparatively coarse texture; and the qualities most desirable in them, are a sufficiently-large aperture to give a *bright* image, combined with such accurate definition as to give a *clear* image, with penetrating power sufficient to prevent any moderate inequalities of surface from seriously interfering with the distinctness of the entire picture, and with perfect flatness of the image when the object itself is flat. For the 2 in. or $1\frac{1}{2}$ in. objective, no ground of judgment

is better, than the manner in which it shows such an 'injected' preparation as the interior of a Frog's lung (Fig. 331) or a portion of the villous coat of the Monkey's intestine (Fig. 328); for the aperture ought to be sufficient to give a bright image of such objects, by ordinary daylight, without the use of a condensing-lens; the border of every vessel should be clearly defined, without any thickness or blackness of edge; every part of such an object that comes within the field, should be capable of being made-out when the focal adjustment is adapted for any other part; whilst, by making that adjustment a medium one, the whole should be seen without any marked indistinctness. If the aperture be too small, the image will be dark; if it be too large, details are brought into view (such as the separateness of the particles of the vermilion-injection) which it is of no advantage to see, whilst, through the sacrifice of penetration, those parts of the object which are brought exactly into focus being seen with over-minuteness, the remainder are enveloped in a thick fog, through which even their general contour can scarcely be seen to loom; and if the corrections be imperfectly made, no line or edge will be seen with perfect sharpness. For *defining* power, the Author has found the pollen-grains of the Hollyhock, or any other flower of the *Malloir*-kind (Fig. 189), viewed as an opaque object, a very good test; the minute spines with which it is beset, being but dimly seen with any save a *good* object-glass of these long foci, and being really-well exhibited only by adding such power to the eyepiece, as will exaggerate any want of definition on the part of an inferior lens. For flatness of field, no test is better than a section of Wood (Fig. 165) or a large Echinus-spine (Fig. 237), under an eye-piece that will give a field of the diameter of from 9 to 12 inches. Such objects ought to be very well shown by the divided lens of 2 in. or 3 in. focus; but, as its corrections are rendered imperfect by the removal of the front pair, its defining power is necessarily impaired, and cannot be made even tolerable, save by such a curtailment of the aperture as detracts from the brightness of the image.—The general performance of object-glasses of 1 in. and 8-10ths in. focus, may be partly judged-of by the manner in which they show such injections as those of the Gill of the Eel (Fig. 330) or of the Bird's Lung (Fig. 332), which require a higher magnifying power for their resolution than those previously named; still better, perhaps, by the mode in which they exhibit a portion of the wing of some Lepidopterous insect, having well-marked

scales; the same qualities should here be looked-for, as in the case of the lowest powers; and a want of either of them is to be distinguished in a similar manner. The increase of angular aperture which these lenses may advantageously receive, should render them capable of resolving all the easier 'test' scales of Lepidoptera, such as those of the *Morpho menelaus* (Fig. 279), in which, with the deeper eyepiece, they should show the transverse as well as the longitudinal markings. The tongue of the common Fly (Fig. 287) is one of the best transparent objects for enabling a practised eye to estimate the general performance of object-glasses of these powers; since it is only under a really good lens, that all the details of its structure can be clearly made-out; and an objective which shows *this* well, may be trusted-to for any other object of its kind. For flatness of field, sections of small Echinus-spines are very good tests. The exactness of the corrections in lenses of these foci, may be judged-of by the examination of objects which are almost sure to exhibit colour, if the correction be otherwise than perfect; this is the case, for example, with the glandulæ of Coniferous wood (Fig. 161), the centres of which ought to be clearly defined under such objectives, and ought to be quite free from colour; and also with the tracheæ of Insects (Fig. 291), the spires of which ought to be distinctly separated from each other, without any appearance of intervening chromatic fringes.

11. We may consider as object-glasses of *medium* power, those which range from half to one-fifth of an inch focus; whose magnifying power is from about 100 to 250 diameters under the shallower eye-piece, and from about 150 to 375 diameters with the deeper. These cannot be advantageously employed in the examination of opaque objects, save of such as are of unusual minuteness; but their great value lies in the information they enable us to obtain, regarding the details of organized structures and of living actions, by the examination of properly-prepared *transparent* objects by transmitted light. It is to these lenses, that the remarks already made respecting angular aperture (§ 101) especially apply; since it is in them that the greatest difference exists, between the ordinary requirements of the scientific investigator, and the special needs of those who devote themselves to the particular classes of objects for which the greatest resolving power is required. A moderate amount of such power is essential to the value of every objective within the above-named range of foci; thus, even a good half-inch should enable the

markings of the larger scales of the *Polyommatus argus* (azure-blue butterfly) to be distinguished, these being of the same kind with those of the Menelaus, but more delicate, and should clearly separate the dots of the small or 'battledoor' scales (Fig. 280) of the same insect, which, if unresolved, are seen as coarse longitudinal lines; a good 4-10ths in. should resolve the larger scales of the *Podura* (Fig. 281) without difficulty; and a good 1-1th or 1-5th in. should bring-out the markings on the smaller scales of the *Podura*, and should resolve the markings on the *Pleurosigma hippocampus* into longitudinal and transverse lines. Even the 4-10ths (a power for which Messrs. Smith and Beck have attained a deserved celebrity) *may* be made with an angle of aperture sufficiently wide to resolve the objects named as fair tests for the powers above it; and so the 1-4th inch *may*, by the enlargement of its angular aperture to 120° (which has been accomplished by Mr. Ross) be made to exhibit the more difficult Diatomacæ. But it will be found that, in such object-glasses, the difficulty of making the most advantageous use of them, and the loss of penetrating power which necessarily attends the excessive extension of their angular aperture, are most serious drawbacks to their practical utility in the hands of the Anatomical or Physiological investigator; for whose purposes, such a resolving power as will show the easier tests first enumerated, combined with perfect definition, with a fair amount of penetrating power, and with flatness of field, constitute the best combination. For defining power, very good tests are found in the complex hairs of many animals, such as the Indian *Bat* (Fig. 310, c) and the *Dermestes* (Fig. 282, b). And for that combination of the several attributes which the Author thinks most important, he has found no test more valuable and positive, as regards objectives of from 4-10ths to 1-5th inch focus, than Mr. Lealand's preparations of Muscular fibre (Fig. 326). In every case, the objective should be tested with the deeper, as well as with the shallower eye-piece; and the effect of this will be a fair test of its merits. Where markings are indistinguishable under a certain objective, merely because of their minuteness or their too close approximation, they may be enlarged or separated by a deeper eye-piece, provided that the objective be well corrected. But if, in such a case, the image be darkened or blurred, so as to be rather deteriorated than improved, it may be concluded that the objective is of inferior quality, having either an insufficient angular aperture, or being imperfectly corrected, or both.

III. All object-glasses of less than 1-5th of an inch focus, may be classed as *high* powers; the focal lengths to which they are ordinarily constructed are 1-6th, 1-8th, 1-12th, and 1-16th of an inch respectively; and the magnifying powers they are fitted to afford, range from about 320 to 850 diameters with the shallower eyepiece, and from 480 to 1300 diameters with the deeper. By the use of still deeper eyepieces, a power of 2000 or more may be easily obtained; but nothing seems to be really gained by such high amplification. Moreover, as the 1-12th inch object-glass may have its angular aperture extended to the utmost limits compatible with the reception of rays from any object, it does not seem that anything can be gained by a reduction of the focal distance to the 1-16th inch; and the latter being a more difficult combination, as well to construct as to use, both Opticians and Microscopists have of late years found it advantageous to limit themselves to the 1-12th, which gives an amplification of about 650 diameters with the shallower eye-piece, and of about 1000 with the deeper.—The use of this class of objectives is much more restricted than that of the preceding. They are not employed for the ordinary purposes of scientific investigation; and their value chiefly lies in the power which they afford, of tracing-out certain points of minute structure, which the objectives of medium power may only doubtfully indicate, and of exhibiting certain classes of very difficult striated or dotted objects, which they cannot resolve. Hence it is obvious that, with regard to object-glasses of *this* class, ‘resolving power’ (coupled with ‘defining power’) is the highest requisite, ‘penetration’ and ‘flatness of field’ being of secondary account; and that the value of an objective may *here* be fairly estimated by its angular aperture, provided that its aberrations be exactly corrected. Of angular aperture and definition, very good tests are afforded by the lines artificially ruled by M. Nobert, and by the more ‘difficult’ species of Diatomaceæ. What is known as ‘Nobert’s Test’ is a plate of glass, on a small space of which, not exceeding a fiftieth of an inch in breadth, are ruled ten or more series of lines, forming as many separate bands of equal breadth; in each of these bands, the lines are ruled at a certain known distance; and the distances are so adjusted in the successive bands, as to form a regularly-diminishing series, and thus ‘to present a succession of tests of progressively-increasing difficulty. The distances of the lines differ on different plates; all the bands in some series

being resolvable under a good objective of 1-4th inch focus, whilst the closest bands in others defy the resolving power of a 1-12th inch objective of large aperture. Thus a 'test-plate' whose *widest* lines are at a distance from each other of 1-1000th of a Paris line, or of 1-11,200th of an English inch, and whose *closest* lines are at 1-5000th of a line, or 1-56,000th of an inch, from each other, will serve as a very fair test for the angular aperture and defining power of object-glasses below 1-4th in. focus; the superiority of each in these particulars, being judged-of by the number of bands which it will resolve into well-defined lines, and by the sharpness and clearness of these lines; while the performance of a 1-4th in. objective may be accounted very satisfactory, if it will enable them all to be clearly distinguished. But if the first of the bands should have an interval of only 1-4000th of a Paris line, or 1-45,000th of an English inch, between its lines, and the last should have its lines approximated to 1-10,000th of a Paris line, or 1-112,000th of an English inch, then only a few of the easier bands will be resolved by the 1-4th in., a few more by the 1-8th in., and even the 1-12th in. will probably not enable any band to be distinctly resolved, whose lines are closer than 1-7000th of a Paris line, or 1-79,000th of an English inch. At present, therefore, the existence of separate lines at a narrower interval than this, is a matter of *faith* rather than of *sight*; but there can be no reasonable doubt that the lines do exist; and the resolution of them would evince the extraordinary superiority of any objective, or of any system of illumination, which should enable them to be distinguished. The mathematical certainty with which the degree of approximation of these lines may be ascertained, and the gradation of the series which they present, gives to M. Nobert's test-plate a very high value for the determination of the relative merits of different objectives, of that class, at least, in which angular aperture and definition are of the first importance; whilst it also serves to test the degree in which these capabilities are possessed by object-glasses of medium power, in which other attributes also have to be considered.—

The value of the minuter *Diatomacea*, as furnishing, in their surface-markings, admirable test-objects for the highest powers of the Microscope, was first made-known by Messrs. Harrison and Sollitt of Hull in 1841; and it cannot be questioned that this discovery has largely contributed to the success of the endeavours which have since been so effectually made, to

perfect this class of objectives, and to find out new methods of using them to the best advantage. The nature of these markings will be described hereafter; and it will be sufficient in this place to give a table of the average distances of the lincation of different species,* which will serve to indicate their respective degrees of difficulty as 'tests.' The greater part of those which are now in use for this purpose, are comprehended in the genus *Pleurosigma* of Prof. W. Smith, which includes those *Navicula* whose 'frustules' are distinguished by their sigmoid (S-like) curvature (§ 184).

	<i>Lines in 1-1000th of an inch.</i>	<i>f</i>
1. <i>Pleurosigma littorale</i>	24	
2. <i>Pleurosigma Hippocampus</i>	30 long., 40 trans.	
3. <i>Pleurosigma strigale</i>	36	
4. <i>Pleurosigma strigosum</i>	44	
5. <i>Pleurosigma elongatum</i>	48	
6. <i>Pleurosigma angulatum</i>	52	
7. <i>Pleurosigma Spenceri</i>	55 long, 50 trans.	
8. <i>Pleurosigma facetola</i>	64	
9. <i>Pleurosigma obscurum</i>	75	
10. <i>Pleurosigma macrum</i>	85	
11. <i>Nitzschia sigmoidea</i>	85	
12. <i>Navicula rhomboides</i>	85	

The first seven of the foregoing may be resolved, with judicious management, by good 1-4th or 1-5th in objectives; the remainder require the 1-8th or 1-12th in., for the satisfactory exhibition of their markings—Several very difficult

* This table is taken from Prof W Smith's admirable Monograph on the Diatomaceæ; and it includes most of the species usually employed as tests. These should always be mounted between two pieces of thin glass, according to the method hereafter to be described (§ 122), in order to avoid, as much as possible, the production of aberrations in the illuminating pencil. The number of lincations must be considered as an average, the extremes sometimes varying to a considerable amount on either side:—A much higher estimate is given by Messrs. Harrison and Sollitt in the "Quart Journ of Microsc. Science," vol ii p 62, the *Pleurosigma facetola* being reckoned by them to contain 90 lines in 1-1000th of an inch, the *Nitzschia sigmoidea* 100 lines, and a species cited as *Navicula arena* (which can scarcely be the one so named by Ehrenberg, and termed by Prof W Smith *Eunotia arena*) no less than 130. The last they speak-of as "so extremely difficult, that, in order even to catch a glimpse of its delicate markings, the observer must be in possession of glasses of a very large angle of aperture and the finest definition, have the most careful management of oblique light, and in addition be possessed of a large share of patience"—The Author cannot but believe that there is some error in these measurements, since, as the well-defined lines upon Nobert's test-plate have not yet been resolved, when they have approximated more closely than the highest numbers mentioned in Prof. W. Smith's table, it can scarcely be imagined possible that the delicate markings of a *Navicula* should even be 'glimpsed,' if they be as much closer than those of the species previously accounted most difficult, as those of the latter are than those of the easiest.

tests of this description have been furnished by Prof. Bailey of West Point (U.S.), among them the very beautiful *Grammatophora subtilissima* and the *Hyaloliscus subtilis*; the latter, being of discoid form, and having markings which radiate in all directions, very much like those of an engine-turned watch, is a useful test for observers who have not facilities for obtaining oblique light in any direction; since, whatever may be azimuth from which the oblique pencil may proceed, some portion of the disk will always be in the best possible position in regard to the light, whereas, in the case of other finely-lined tests, it is only when the most favourable position has been attained, perhaps after tedious and troublesome trials, that the markings are displayed.*

103. *Determination of Magnifying Power.*—The last subject to be here adverted-to, is the mode of estimating the magnifying power of Microscopes, or, in other words, the number of times that any object is magnified. This will of course depend upon a comparison of the *real* size of the object, with the *apparent* size of the image; but our estimate of the latter will depend upon the distance at which we assume it to be seen, since, if it be projected at different distances from the eye, it will present very different dimensions. Opticians generally, however, have agreed to consider *ten inches* as the standard of comparison; and when, therefore, an object is said to be magnified 100 diameters, it is meant that its visual image, projected at 10 inches from the eye (as when thrown-down by the Camera Lucida, § 49) upon a surface at that distance beneath, has 100 times the actual dimensions of the object. The measurement of the magnifying power of Simple or Compound Microscopes by this standard is attended with no difficulty. All that is required is a stage-micrometer accurately divided to a small fraction of an inch (the 1-100th will answer very well for low powers, the 1-1000th for high), and a common foot-rule divided to tenths of an inch. The micrometer being adjusted to the focus of the objective, the rule is held parallel with it, at the distance of ten inches from the eye. If the second eye be then opened, whilst the other is looking at the object, the circle of light included within the field of view, and the object itself, will be seen faintly projected upon the rule: and it will be very easy to mark upon the latter the apparent distances of the divisions on the micrometer, and thence to

* See Prof. Bailey's interesting memoirs in vols. II and VII of the "Smithsonian Contributions to Knowledge."

ascertain the magnifying power. Thus, supposing each of the divisions of 1-100th of an inch to correspond with $1\frac{1}{2}$ inch upon the rule, the linear magnifying power is 150 diameters; if it correspond with half an inch, the magnifying power would be 50 diameters. If, again, each of the divisions of the 1-1000th inch micrometer correspond to 6-10ths of an inch upon the rule, the magnifying power is 600 diameters; and if it correspond to $1\frac{2}{10}$ inch, the magnifying power is 1200 diameters. In this mode of measurement, the estimate of *parts* of tenths on the rule can only be made by guess; but greater accuracy may be obtained by projecting the micrometer-scale with the Camera Lucida at the distance of ten inches from the eye, marking the intervals on paper, taking an average of these, and repeating this with the compasses ten times along the inch-scale. Thus, if the space given by one of the divisions of the 1-1000th-inch micrometer, repeated ten times along the rule, gave 6 inches and $2\frac{1}{2}$ tenths, the value of each division would be $\cdot 625$ of an inch, and the magnifying power 625.—The *superficial* magnifying power is of course estimated by *squaring* the linear; but this is a mode of statement never adopted by scientific observers, although often employed to excite popular admiration, or to attract customers, by those whose interest is concerned in doing so.*

* An ingenious method has been devised by Prof Harting, of Utrecht, for determining "the utmost limits of penetrating and separating power possessed by a Microscope," by using as test-objects the very reduced images of various bodies formed by air-bubbles in gum-mucilage. The mode of obtaining and employing these images for the above purpose, will be found in the "Quarterly Journal of Microscopical Science," vol. 1., p. 292.

CHAPTER V.

PREPARATION, MOUNTING, AND COLLECTION OF OBJECTS.

UNDER this head it is intended to give such *general* directions respecting the preparation, mounting, and collection of Objects, as will supersede the necessity of frequent repetition when each particular class is described; and also to enumerate the materials and appliances, which will be required or found advantageous.

Section 1.—*Preparation of Objects.*

104. *Microscopic Dissection.*—The separation of the different parts of an Animal or Vegetable structure by dissection, so as to prepare any portion for being minutely examined under the Microscope, should be accomplished, so far as may be found practicable, with the naked eye; but the best mode of doing this, will depend in great degree upon the size and character of the object. Generally speaking, it will be found advantageous to carry-on the dissection under water, with which alcohol should be mingled where the substance has been long immersed in spirit. The size and depth of the vessel should be proportioned to the dimensions of the object to be dissected; since, for the ready access of the hands and dissecting-instruments, it is convenient that the object should neither be far from its walls, nor lie under any great depth of water. Where there is no occasion that the bottom of the vessel should be transparent, no kind of dissecting-trough is more convenient, than that which every one may readily make for himself, of any dimensions he may desire, by taking a piece of sheet gutta percha of adequate size and stoutness, warming it sufficiently to render it flexible, and then turning-up its four sides, drawing-out each corner into a sort of spout, which serves to pour-away its contents when it needs emptying. The dark-colour of this substance enables it to furnish a back-ground, which assists the observer in distinguishing delicate membranes, fibres, &c., especially when magnifying lenses are employed; and it is hard enough, without being too hard, to allow of pins being fixed into it, both for securing the object, and for

keeping-apart such portions as it is useful to put on the stretch. When glass or earthenware troughs are employed, a piece of sheet-cork, loaded with lead, must be provided, to answer the same purposes. In carrying-on dissections in such a trough, it is frequently desirable to concentrate additional light upon the part which is being operated-on, by means of the smaller condensing lens (Fig. 45); and when magnifying power is wanted, it may be supplied either by a single lens, mounted after the manner of Ross's Simple Microscope (Fig. 11, B), or by a Compound body mounted as in one of Mr. Warington's arrangements (Fig. 24). Portions of the body under dissection, being floated-off when detached, may be conveniently taken-up from the trough by placing a slip of glass beneath them (which is often the only mode in which delicate membranes can be satisfactorily spread-out); and may be then placed under the microscope for minute examination, being first covered with thin glass, beneath the edges of which is to be introduced a little of the liquid wherein the dissection is being carried-on. Where the body under dissection is so transparent, that more advantage is gained by transmitting light through it, than by looking at it as an opaque object, the trough should have a glass bottom; and for this purpose, unless the body be of unusual size, some of the glass 'cells' to be hereafter described (§§ 136, 137) will usually answer very well. The finest dissections may often be best made upon ordinary slips of glass; care being taken to keep the object sufficiently surrounded by fluid. For work of this kind, no simple instrument is more generally serviceable than Mr. Quekett's Dissecting Microscope (Fig. 17); but if higher magnifying powers be needed than this will conveniently afford, recourse may be had to Smith and Beck's Dissecting Microscope (Fig. 29), which for this purpose should always be furnished with the Erector (Fig. 32).—A particular arrangement of the light, devised many years since by the Author, will enable an expert dissector to prosecute his work with the naked eye, to an extent for which a lens would otherwise be required. This consists in giving to the object the same kind of black-ground illumination, as is now in common use for a very different purpose; and nothing more is necessary to afford it, than to attach to the under side of the stage a sort of 'well,' composed of a tube blackened in its interior, about $1\frac{1}{2}$ inch long, of the same diameter as the opening of the stage-plate, into the lower extremity of which a diaphragm or a ground-glass may be fitted, for the purpose of diminishing

or of softening the light. The slide being laid upon the stage, and the mirror being so turned as to illuminate the object, the eye is to be so placed (the arm carrying the magnifiers being turned to one side) that the object is seen against the dark background afforded by the side of the well. In this manner, fibres of extreme minuteness, or other particles of extraordinary delicacy, can be clearly distinguished, such as could otherwise be scarcely discerned at all without the assistance of a magnifier. And the further the dissection can be carried in this mode, the less difficulty will be found in completing it, when the simple or compound Microscope is brought to bear upon it.—Whenever a dissection is being made upon the stage of a microscope, it is desirable that support should be provided for the hands on either side. This may be given by books or blocks of wood piled-up to the requisite height; but in place of *flat* ‘rests,’ it is much more convenient to provide a pair of *inclined planes*, sloping-away from the stage at an angle of about 30° below the horizon. These may be either solid blocks of wood, or (which is much less cumbrous) they may be made of two boards hinged-together, one giving the inclined plane, which rests at one end upon the table, while the other, standing vertically, affords the requisite elevation to the extremity which abuts against the stage.

105. The instruments used in Microscopic dissection, are for the most part of the same kind as those which are needed in ordinary minute Anatomical research, such as scalpels, scissors, forceps, &c.; the fine instruments used in operations upon the eye, however, will commonly be found most suitable. A pair of delicate scissors curved to one side, is extremely convenient for cutting open tubular parts; these should have their points blunted; but other scissors should have fine points. A pair of fine-pointed scissors (Fig 56), one leg of



Spring-Scissors.

which is fixed in a light handle, and the other kept-apart from it by a spring, so as to close by the pressure of the finger and to open of itself, will be found (if the blades be well sharpened

on a hone) much superior to any kind of knives, for cutting through delicate tissues with as little disturbance of them as possible: Swammerdam is said to have made great use of this instrument in his elaborate insect-dissections. Another cutting instrument much used by some dissectors, may be designated as a miniature of the shears used in shearing sheep, or as a cutting-forceps; the blades of such an instrument may be prevented from springing too far asunder, by means of a regulating-screw (as in the 'microtome' of M Strauss-Durckheim) or by some other kind of check; and the cutting action, being executed by the opposed pressure of the finger and thumb, may be performed with great precision. A pair of small straight forceps, with fine points, and another pair of curved forceps, will be found useful in addition to the ordinary dissecting-forceps.—Of all the instruments contrived for delicate dissections, however, none are more serviceable than those which the Microscopist may make for himself out of ordinary needles. These should be fixed in light wooden handles* (the cedar sticks used for camel-hair pencils, or the handles of steel-pen-holders, will answer extremely well), in such a manner that their points should not project far,† since they will otherwise have too much 'spring.' much may be done by their mere *tearing* action; but if it be desired to use them as *cutting* instruments, all that is necessary is to give them an edge upon a hone. It will sometimes be desirable to give a finer point to such needles, than they originally possess; this also may be done upon a hone. A needle with its point bent to a right angle, or nearly so, is often useful; and this may be shaped by simply heating the point in a lamp or candle, giving to it the required turn with a pair of pliers, and then hardening the point again by re-heating it and plunging it into cold water or fallow.

* Special *needle-holders* (like miniature port-crayons) have been made for this purpose, and although they afford the facility of lengthening or shortening the acting point of the needle at will, and also of carrying a reserve store of needles at the other end, yet the Author would decidedly recommend the use of the wooden handles, of which a large stock may be obtained for a trifle.

† The following is the mode in which the Author has found it convenient to mount his needles for this and other purposes—the needle being held firmly in a pair of pliers grasped by the right hand, its point may be forced into the end of a cedar or other stick held in the left, until it has entered to the depth of half an inch or more; the needle is then cut-off to the desired length (the eye-end being thus got-rid-of), and being then drawn-out, the truncated end is forced into the hole previously made by the point, until it cannot be made to penetrate further, when it will be found to be very securely fixed. The end of the handle which embraces it, may then be bevelled away round its point of insertion.

106. *Cutting Sections of Soft Substances.*—Most important information respecting the structure of many substances, both Animal and Vegetable, may be obtained by cutting sections of them, thin enough to be viewed as transparent objects. Where the substances are soft, no other instrument is necessary for this purpose, than a sharp knife, which may be best made with a thin two-edged blade like that of a lancet; considerable practice is needed, however, to make effectual use of it; and some individuals acquire a degree of dexterity, which others never succeed in attaining. In cutting sections of Animal tissues, which, owing to the quantity of water they contain, do not present a sufficiently firm resistance, it is often desirable to half-dry these, by exposing small pieces freely to the

FIG



Curved Scissors
for cutting Thin
Sections.

air, with the aid of a gentle warmth if required; when this desiccating process has been carried sufficiently far, thinner sections can be cut, than could possibly have been made in the original state of the tissue; and the texture, after a short maceration in water, almost entirely recovers its pristine characters. There are certain tissues, however, which will not bear to be thus treated, and of which it is sufficient to examine an extremely minute portion; and for making sections of these, such a pair of scissors as is represented in Fig. 57 will often be found very useful; since, owing to the curvature of the blades,* the two extremities of a section taken from a flat surface will generally be found to thin-away, although the middle of it may be too thick to exhibit any structure.—Where only a moderate degree of thinness is required, either in consequence of the transparency of the tissue, or because it is not desired to exhibit its minutest details, the two-bladed

* It is difficult to convey by a drawing the idea of the real curvature of this instrument, the blades of which, when it is held in front view, curve—not to either side—but towards the observer; these scissors being, as the French instrument-makers say, *courbés sur le plat*. As an example of the utility of such an instrument to the Microscopist, the Author may cite the curious demonstration given a few years since, by Dr. Aug. Waller, of the structure of the gustative papillæ, by snipping-off the papillæ from the living human tongue, which may be done with no more pain than the prick of a pin would occasion.

knife contrived by Prof. Valentin (Fig. 58) may be employed with advantage. The blades are attached to each other at

FIG. 58.



Valentin's Knife.

their lower end by a screw, in such a manner that their 'spring' tends to keep them apart; and their distance is regulated by pushing the little rivet backwards or forwards in the slit through which it works. The knife should be dipped in water before using, or, still better, the section should be made under water, as the instrument works much better when wet; after use, it should be carefully washed and dried, a piece of soft leather being passed between the blades. If any water have found its way into the part through which the rivet works, the moveable blade should be detached by taking out its screw, and each blade should be cleaned separately.*

107. *Cutting Sections of Harder Substances.*—There is a large class of substances, both Animal and Vegetable, which are too hard to admit of sections being made in the manner just described, but of which extremely thin slices can be made by a sharp cutting instrument, if only they be properly held and supported,—more especially when the thickness of the section can be regulated by a mechanical contrivance; such are, in particular, the Stems and Roots of Plants, and the Horns, Hoofs, Cartilages, and similarly-firm structures of Animals. Various costly machines have been devised for this purpose, some of them characterized by great ingenuity of contrivance and beauty of workmanship; but every purpose to which these are adapted, will be found to be answered by a very simple and unexpensive little instrument, which may either be held in the hand, or (which is preferable) may be firmly attached by means of a T-shaped piece of wood (as in Fig. 59), to the end of a table or work-bench. This instrument essentially consists of an upright hollow cylinder of brass, with a kind of piston which is pushed from below upwards by a fine-threaded screw,

* An improved form of this instrument is constructed by Mr. Matthews of Portugal-street, the blades being made with a convex instead of a straight edge, their distance from each other being regulated by a milled-head screw, and their separation for cleaning being more easily accomplished.

turned by a large milled-head; at the upper end, the cylinder terminates in a brass table, which is made to present a perfectly flat surface. At one side is seen a small milled-head, which acts upon a 'binding-screw,' whose extremity projects

FIG. 59.

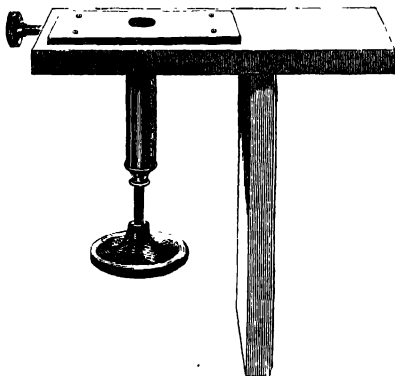

Section Instrument.

into the cavity of the cylinder, and serves to compress and steady anything that it holds. A cylindrical stem of wood, a piece of horn, whalebone, cartilage, &c., is to be fitted to the interior of the cylinder, so as to project a little above its top, and is to be steadied by the 'binding-screw;' it is then to be cut to a level by means of a sharp knife or razor, laid flat upon the table. The milled-head is next to be moved through such a portion of a turn, as may very slightly elevate the substance to be cut, so as to make it project in an almost insensible degree above the table; and this projecting part is to be sliced-off with a knife, previously dipped in water. The best knife for this purpose is a razor, ground flat (instead of concave) on one side, but having still a concave surface on the other; the flat side is to be laid downwards upon the table; and the motion given to the edge should be a combination of *drawing* and *pressing*. (It will be generally found that better sections are made, by working the knife *from* the

operator, than *towards* him.) When one slice has been thus taken-off, it should be removed from the blade by dipping it into water, or by the use of a camel-hair brush; the milled-head should be again advanced, and another section taken; and so on. Different substances will be found both to *bear* and to *require* different degrees of thickness; and the amount that suits each can only be found by trial. It is advantageous to have the large milled-head graduated, and furnished with a fixed index; so that this amount having been once determined, the screw shall be so turned as to always produce the exact elevation required.—Where the substance of which it is desired to obtain sections by this instrument, is of too small a size or of too soft a texture to be held firmly in the manner just described, it may be placed between the two vertical halves of a cork of suitable size to be pressed into the cylinder; and the cork, with the object it grasps, is then to be sliced in the manner already described, the small section of the latter being carefully taken-off the knife, or floated-away from it, on each occasion, to prevent it from being lost among the lamellæ of cork which are removed at the same time.—The special methods of preparation which are required in the case of the various substances, of which sections may be conveniently cut by this instrument, will be described under their several heads.

108. *Grinding and Polishing of Sections.*—Substances which are too hard to be sliced with a cutting instrument in the manner last described,—such as bones, teeth, shells, corals, fossils of all kinds, and even some recent vegetable tissues,—can only be reduced to the requisite thinness for Microscopical examination, by grinding-down thick sections, until they become so thin as to be transparent. The general method of making such preparations will be here described;* but those special details of management which particular substances may require, will be given when these substances are respectively described.—The first thing to be done, will usually be to procure a *section* of the substance, as thin as it can be safely cut. Most substances not siliceous may be divided by the fine saws used by artisans for cutting brass; but there are some bodies (such as the enamel of teeth, and porcellanous shells), which, though merely calcareous, have their mineral

* The following directions do not apply to *Siliceous* substances; as sections of these can only be prepared by those who possess a regular Lapidary's apparatus, and who have been specially instructed in the use of it.

particles arranged in such a peculiar state of aggregation, as to make it very difficult and tedious to divide them in this mode; and it is much the quicker operation to *slit* them with a disk of soft iron (resembling that used by the lapidary) charged at its edge with diamond-dust, which may be driven in an ordinary lathe. Where waste of material is of no account, a very expeditious method of obtaining pieces fit to grind-down, is to detach them from the mass with a strong pair of 'cutting-pincers,' or, if it be of small dimensions, with 'cutting-pliers;' and a flat surface must then be given to it, either by holding it to the side of an ordinary grindstone, or by rubbing it on a plate of lead (cast or planed to a perfect level) charged with emery, or by a strong-toothed file, the former being the most suitable for the *hardest* substances, the latter for the *toughest*. There are certain substances, especially calcareous fossils of wood, bone, and teeth, in which the greatest care is required in the performance of these preliminary operations, on account of their extreme friability; the vibration produced by the working of the saw or the file, or by grinding on a rough surface, being sufficient to disintegrate even a thick mass, so that it falls to pieces under the hand; such specimens, therefore, it is requisite to treat with great caution, dividing them by the smooth action of the wheel, and then rubbing them down upon nothing rougher than a very fine 'grit.' Where (as often happens) such specimens are sufficiently porous to admit of the penetration of Canada Balsam, it will be desirable, after soaking them in turpentine for a while, to lay some liquid balsam upon the parts through which the section is to pass, and then to place the specimen before the fire or in an oven for some little time, so as first to cause the balsam to run-in, and then to harden it; by this means the specimen will be rendered much more fit for the processes it has afterwards to undergo.—It not unfrequently happens, that the small size, awkward shape, or extreme hardness of the body, occasions a difficulty in holding it either for cutting or grinding; in such a case, it is much better to attach it to the glass in the first instance, by any side that happens to be flattest; and then to rub it down by means of the 'hold' of the glass upon it, until the projecting portion has been brought to a plane, and has been prepared for permanent attachment to the glass. This is the method which it is generally most convenient to pursue with regard to small bodies; and there are many which can scarcely

be treated in any other way, than by attaching a number of them to the glass at once, in such a manner as to make them mutually support one another.*

109. The mode in which the operation is then to be proceeded-with, depends upon whether the section is to be ultimately set-up in Canada balsam (§ 125), or is to be mounted dry (§ 122), or in fluid (§ 132). In the former case, the following is the plan to be pursued. The flattened surface is to be polished, by rubbing it with water on a 'Water-of-Ayr' stone, on a hone or 'Turkey'-stone, or on a new stone recently introduced under the name of the 'Arkansas'-stone; the first of the three is the best for all ordinary purposes; but the two latter, being much harder, may be employed for substances which resist it.† When this has been sufficiently accomplished, the section is to be attached with Canada balsam to a slip of thick well-annealed glass; and, as the success of the final result will often depend upon the completeness of its adhesion to this, the means of most effectually securing that adhesion will now be described in detail. Some Canada balsam, previously rendered somewhat stiff by the evaporation of part of its turpentine, is to be melted on the glass slip, so as to form a thick drop, covering a space somewhat larger than the area of the section; and it should then be set aside to cool, during which process, the bubbles that may have formed in it will usually burst. When cold, its hardness should be tested, which is best done by the edge of the thumbnail; for it should be with difficulty indented by its pressure, and yet should not be so resinous as to be brittle. If it be too soft, as indicated by its too-ready yielding to the thumbnail, it should be boiled a little more; if too hard, which will be shown by its chipping, it should be re-melted and diluted with more-fluid balsam, and then set aside to cool as before. When it is found to be of the right consistence, the section should be laid upon its surface, with the polished side down-

* Thus, in making horizontal and vertical sections of Foraminifera, as it would be impossible to cut them through, they must be laid close together in a bed of hardened Canada-balsam on a slip of glass, in such positions, that, when rubbed down, the plane of section shall traverse them in the desired directions; and one flat surface having been thus obtained for each, this must be turned downwards, and the other side ground away.

† As the *flatness* of the polished surface is a matter of the first importance, that of the stones themselves should be tested from time to time; and whenever they are found to have been rubbed-down on any one part more than on another, they should be flattened on a paving-stone with fine sand, or on the lead-plate with emery.

wards; the slip of glass is next to be gradually warmed until the balsam is softened, special care being taken to avoid the formation of bubbles; and the section is then to be gently pressed-down upon the liquefied balsam, the pressure being at first applied rather on one side than over its whole area, so as to drive the superfluous balsam in a sort of wave towards the other side, and an equable pressure being finally made over the whole. If this be carefully done, even a very large section may be attached to glass, without the intervention of any air-bubbles; if, however, they should present themselves, and they cannot be expelled by increasing the pressure over the part beneath which they are, or by slightly shifting the section from side to side, it is better to take the section entirely off, to melt a little fresh balsam upon the glass, and then to lay the section upon it as before.

110. When the section has been thus secured to the glass, and the attached part thoroughly saturated (if it be porous) with hard Canada-balsam, it may be readily reduced in thickness, either by grinding or filing as before, or, if the thickness be excessive, by taking-off the chief part of it at once by the slitting-wheel. So soon, however, as it approaches the thinness of a piece of ordinary card, it should be rubbed-down with water on one of the smooth stones previously named, the glass slip being held beneath the fingers with its face downwards, and the pressure being applied with such equality, that the thickness of the section shall be (as nearly as can be discerned) equal over its entire surface. As soon as it begins to be translucent, it should be placed under the Microscope (particular regard being had to the precaution specified in § 86), and note taken of any inequality; and then, when it is again laid upon the stone, such inequality may be brought-down, by making special pressure with the fore-finger upon the part of the slide above it. When the thinness of the section is such as to cause the water to spread around it between the glass and the stone, an excess of thickness: on either side may often be detected, by noticing the smaller distance to which the liquid extends. In proportion as the substance attached to the glass is ground-away, the superfluous balsam which may have exuded around it will be brought into contact with the stone; and this should be removed with a knife, care being taken, however, that a margin be still left round the edge of the section. As the section approaches the degree of thinness which is most suitable for the display of its organization, great care must be taken that the grinding process be

not carried too far; and frequent recourse should be had to the Microscope, which it is convenient to have always at hand, when work of this kind is being carried-on. There are many substances whose intimate structure can only be displayed in its highest perfection, when a very little more reduction would destroy the section altogether; and every Microscopist who has occupied himself in making such preparations, can tell of the number which he has sacrificed in order to attain this perfection. Hence if the amount of material be limited, it is a good rule to stop-short as soon as a *good* section has been made, and to lay it aside—"letting well alone"—whilst the attempt is being made to procure a *better* one; if this should fail, another attempt may be made, and so on, until either success has been attained, or the whole of the material has been consumed,—the *first* section, however, still remaining: whereas, if the first, like every successive section, be sacrificed in the attempt to obtain perfection, no trace will be left to "show what has been."—In judging of the appearance of sections in this stage under the Microscope, it is to be remembered that its transparency will subsequently be considerably increased by mounting in Canada balsam (§ 125): this is particularly the case with fossils, to which a deep hue has been given by the infiltration of some colouring matter; and with any substances whose particles have a molecular aggregation, that is rather amorphous than crystalline.—When a sufficient thinness has been attained, the section may generally be 'mounted' in Canada balsam; and the mode in which this must be managed, will be detailed hereafter (§ 129).

111. As there are certain substances, however, the view of whose structure is impaired by mounting in Canada balsam, and which should therefore be mounted either dry or in fluid, a different method of procedure must be adopted with them. If tolerably thin sections of them can be cut in the first instance, or if they are of a size and shape to be held in the hand whilst they are being roughly ground-down, there will be no occasion to attach them to glass at all; it is frequently convenient to do this at first, however, for the purpose of obtaining a 'hold' upon the specimen; but the surface which has been thus attached, must afterwards be completely rubbed-away, in order to bring into view a stratum which the Canada balsam shall not have penetrated. As none but substances possessing considerable toughness, such as bones and teeth, can be treated in this manner, and as these are the substances

which are most quickly reduced by a coarse file, and are least liable to be injured by its action, it will be generally found possible to bring the sections to a considerable thinness, by laying them upon a piece of cork or soft wood held in a vice, and operating upon them first with a coarser and then with a finer file. When this cannot safely be carried further, the section must be rubbed-down upon that one of the fine stones already mentioned (§ 109), which is found best to suit it; as long as the section is tolerably thick, the finger may be used to press and move it; but as soon as the finger itself begins to come into contact with the stone, it must be guarded by a flat slice of cork, or by a piece of gutta-percha, a little larger than the object. Under either of these, the section may be rubbed-down until it has been reduced to the requisite degree of tenuity; but even the most careful working, on the finest-grained stone, will leave its surface covered with scratches, which not only detract from its appearance, but prevent the details of its internal structure from being as readily made-out, as they can be in a polished section. This polish may be imparted, by rubbing the section with putty-powder (peroxide of tin) and water, upon a leather strap, made by covering the surface of a board with buff-leather, having three or four thicknesses of cloth, flannel, or soft-leather beneath it; this operation must be performed on both sides of the section, until all the marks of the scratches left by the stone shall have been rubbed-out; when the specimen will be fit for mounting, after having been carefully cleansed from any adhering particles of putty-powder.

112. *Chemical Actions*.—One important part of the preparation of Microscopic objects, is often effected by the use of Chemical Re-agents. These may be employed, either for the sake of *removing* substances of which it is desired to get-rid, in order to bring something else into view; or for the sake of *detecting* the presence of particular substances in the object under examination.—Thus, in order to obtain the animal basis of Shell, Bone, Tooth, &c., it is necessary to dissolve away the calcareous portion of these tissues by the use of acids; a mixture of nitric and muriatic acids is preferable; and this should be added, little by little, to a considerable bulk of water, until a disengagement of gas be perceived to commence from the surface of the specimen. Care should always be taken not to hurry the process by adding too much acid, since, when the animal membrane is of very delicate consistence, it is liable to be dissolved; and in some cases it is

better to allow the action to go on for many weeks, adding only a drop or two of acid at a time. When siliceous particles are to be removed (such as those which form the *loricæ* of the Diatomacæ), for the sake of leaving the organic membrane in a state adapted to separate examination, hydrofluoric acid must be employed as the menstruum. It is sometimes necessary, on the other hand, to get rid of the organic matter, for the sake of obtaining the mineral particles in a separate state, as in the case of the spicules of Sponges, Gorgonia, &c., this may be done either by incineration, or (which is generally preferable) by boiling or macerating for a long time in a solution of caustic potash. In separating from Guano, again, the siliceous skeletons of Diatomacæ, &c., which it may contain, muriatic and nitric acids are largely used, to dissolve-away every part of the mass on which they will act; the microscopic organisms for which search is made, being contained in the few grains of sediment which are left when a pound of pure guano is thus treated.

113. In applying Chemical Re-agents to Microscopic objects for the purpose of *testing*, it is necessary to use great care not to add too much at once; and it is better that the test-bottle itself should afford the means of regulating the quantity, than that an additional rod or tube should be required. Two modes have been devised for this purpose.—One consists in drawing the neck of the test-bottle to a capillary orifice, and covering it with a cap which fits around it; and the fluid is caused to flow from this, drop by drop, by the warmth of the hand applied to the bottle, which causes an expansion of the air it may contain.* When these bottles are emptied, they must be re-filled by expelling the air by heat, and placing the capillary orifice under the surface of the fluid to be introduced, which will then be forced-in as the bottle cools; this process may need to be repeated two or three times (care being taken that the heat applied be not so great as to crack the bottle); but it is better not to fill the bottle more than half-full, in order that air enough may be left for the warmth of the hand to act-upon.—The other arrangement for applying minute quantities of test-liquids, consists in the elongation of the stopper, which is drawn to a fusiform point, so as to serve as the test-rod for its own bottle.† This enables either a mere trace, or

* A set of 12 test-bottles on this plan, packed in a box, is supplied by Mr. Higley of Fleet-street.

† Bottles of this pattern, which was devised by Dr. Griffith, are sold by Mr. Ferguson of Giltspur-street.

several ordinary drops, of the re-agent to be applied at once; for the elongated stopper will take-up a considerable quantity, a larger or smaller proportion of which (as desired), may be left-behind, by bringing the lower part of the stopper into contact with the inside of the neck of the bottle, as it is being withdrawn.—Whichever plan is made use of, great care should be taken to avoid carrying-away from the slide to which the test-liquid is applied, any loose particles which may be upon it, and which may be thus transferred to some other object, to the great perplexity of the Microscopist. It is better, indeed, not to deposit the drop of test-liquid on the slide in immediate contact with the substance to which it is to be applied; but to bring the two into contact after the test-bottle has been withdrawn.

114. The following are the Test-Liquids most frequently needed.

1. Solution of *Iodine* in water (1 gr. of iodine, 3 grs. of iodide of potassium, 1 oz. of distilled water) turns starch blue, and cellulose brown; it also gives an intense brown to albuminous substances.

2. Dilute *Sulphuric Acid* (one of acid to two or three parts of water) gives to cellulose that has been previously dyed with iodine, a blue or purple hue; also, when mixed with a solution of sugar, it gives a rose-red hue, more or less deep, with nitrogenous substances and with bile (Pettenkofer's test).

3. Solution of chloride of zinc, iodine, and iodide of potassium, made in the following way.—Zinc is dissolved in hydrochloric acid, and the solution is permitted to evaporate, in contact with metallic zinc, until it attains the thickness of a syrup; this syrup is then saturated with iodide of potassium, and iodine is last added. This solution (which is known as Schultz's test) serves, like the preceding, to detect the presence of cellulose, and has the advantage over sulphuric acid of being less destructive to the tissues. Each will sometimes succeed where the other fails; consequently, in doubtful cases, both should be employed.

4. Concentrated *Nitric Acid* gives to albuminous substances an intense yellow; when diluted with about two or three parts of water, it is very useful in separating the elementary parts of many Animal and Vegetable tissues, when these are boiled in it.

5. *Acetic Acid* (diluted with from three to five parts of water) is a most useful test-liquid to the Animal Histologist, from its power of dissolving, or at least of reducing to a state

of such transparency that they can no longer be distinguished, certain membranes, fibres, &c.; whilst others are brought strougly into view.

6. *Acid Nitrate of Mercury* (Millon's test) colours albuminous substances red.

7. Solution of caustic *Potash* or *Soda* (the latter being generally preferable) has a remarkable solvent effect upon many organic substances, both Animal and Vegetable.

8. *Alcohol* dissolves resinous substances and many vegetable colouring-matters, and renders most vegetable preparations more transparent; on the other hand, by its coagulating action, it renders many animal tissues (as nerve-fibres) more opaque, and thus brings them into greater distinctness.

9. *Ether* dissolves not only resins, but oils and fats.

Section 2. *Mounting of Objects.*

115. The Microscopist not merely desires to prepare objects for examination, but, where possible, to preserve them in such a manner that they may be inspected at any future time. This may be so effectually accomplished in regard to many substances, that they undergo no kind of change, however long they may be retained; and even delicate structures whose composition renders them peculiarly liable to decay, may often be kept, by complete seclusion from the air, and by immersion in a preservative fluid, in a state so nearly resembling that in which they were at first prepared, that they will continue, during an indefinite length of time, to exhibit their original characters with scarcely any deterioration.—The method of 'mounting' objects to be thus preserved, will differ, of course, both according to their respective natures, and also according to the mode in which they are to be viewed, whether as *transparent* or as *opaque* objects. Thus they may be set-up dry, or in Canada balsam, or in some preservative liquid; they may need to be simply covered with thin glass, or they may require to be surrounded by a 'cell;' if they are to be viewed by transmitted light, they must always have glass below them; but if they are to be seen by the light reflected from their surfaces, they may often be preferably mounted on wood, card, or some other material which itself affords a black back-ground. In almost all cases in which transparent objects are to be mounted, use will have to be made of the slips of glass technically called *slides* or *sliders*, and of *covers* of thin glass, and it will therefore be desirable to treat of these in the first instance.

116. *Glass Slides*.—The kind of glass usually employed for mounting objects, is that which is known as ‘flatted crown;’ and it is now almost invariably cut, by the common consent of Microscopists in this country, into slips measuring 3 in. by 1 in.; for objects too large to be mounted on these, the size of 3 in. by 1½ in. may be adopted. Such slips may be purchased, accurately cut to size, and ground at the edges, for so little more than the cost of the glass, that few persons to whom time is an object would trouble themselves to prepare them; it being only when glass slides of some unusual dimensions are required, or when it is desired to construct ‘built-up cells’ (§§ 136, 137), that a facility of cutting glass with the glazier’s diamond becomes useful.—The glass slides prepared for use, should be free from veins, air-bubbles, or other flaws, at least in the central part on which the object is placed; and any whose defects render them unsuitable for ordinary purposes, should be selected and laid-aside for uses to which the working Microscopist will find no difficulty in putting them. As the slips vary considerably in thickness, it will be advantageous to separate the *thick* from the *thin*, and both from those of *medium* substance: the last may be employed for mounting ordinary objects; the second for mounting delicate objects to be viewed by the high powers, with which the achromatic condenser is to be used, so as to avoid any unnecessary refraction of the illuminating pencil by the thickness of the plate which it has to traverse beneath the object; whilst the first should be set-aside for the attachment of objects which are to be ground-down, and for which, therefore, a stronger mounting than usual is desirable. Where very hard substances have to be thus operated-on, it is advantageous to attach them in the first instance to pieces of very thick plate-glass; only transferring them to the ordinary slides, when they have been reduced to nearly the requisite thinness (§ 129).

117. *Thin-Glass*.—The older Microscopists were obliged to employ thin laminae of *talc*, for covering objects to be viewed with lenses of short foci; but this material, which was in many respects objectionable, is now entirely superseded by the thin-glass manufactured for this express purpose by Messrs. Chance of Birmingham, which may be obtained of various degrees of thickness, from 1-20th to 1-250th of an inch. This glass, being unannealed, is very hard and brittle; and much care and some dexterity are required in cutting it. This should be done with the *writing* diamond; and it is

advantageous to lay the thin-glass upon a piece of wetted plate-glass, as its tendency to crack and 'star' is thereby diminished. For cutting *square* or other *rectangular* covers, nothing but a flat rule is required. For cutting *rounds* or *ovals*, on the other hand, it is necessary to have 'guides' of some kind. The simplest, which are as effective as any, consist of pieces of flat brass-plate, perforated with holes of the various sizes desired; or curtain-rings, with a piece of wire soldered on either side: these being held firmly down on the thin-glass with two fingers of the left hand, the writing-diamond is carried round the inner margin of the aperture with the right; care being taken that, in so doing, the diamond be made to revolve on its own axis, which is needful both that it may mark the glass, and also that the beginning and the end of the cut may join.* Where a number of such 'rounds' are being cut at once, it saves much trouble, as well as risk of loss by breakage in separating them, to cut the glass first into strips, whose breadth shall equal the diameter of the rounds. But it is very convenient to use-up for this purpose any odd pieces of glass, whose shape may render them unsuitable for being cut into 'squares' without much waste.—The pieces of thin glass thus prepared for use, should be sorted, not only according to size and shape, but also according to thickness. The thinnest glass is of course most difficult to handle safely, and is most liable to fracture from accidents of various kinds; and hence it should only be employed for the purpose for which it is absolutely needed,—namely, the mounting of objects which are to be viewed by the highest powers. The thickest pieces, again, may be most advantageously employed as covers for large cells in which objects are mounted in fluid (§§ 136, 137), to be viewed by the low powers, whose performance is not sensibly affected by the aberration thus produced. And the pieces of medium thickness will be found those most serviceable for all ordinary

* A very elegant little instrument, for the purpose of cutting thin-glass-rounds, contrived by Mr. Shadbolt, and another, of a more substantial character, invented by Mr. Darker, will be found described in Mr. Quckett's "Practical Treatise." These instruments, however, are rather adapted for the use of those who have occasion to prepare such rounds in large quantities, than for the ordinary working Microscopist, who will find the method above described answer his requirements sufficiently well. Indeed it is in some respects superior; since a firm pressure made by the ring or plate on the glass around, tends to prevent the crack from spreading into it.—To every one to whom the saving of *time* is a greater object than the expenditure of a few shillings, it is strongly recommended that these 'rounds' should be purchased ready-cut; as they may be obtained of any required size and thickness, at a very moderate cost.

purposes; neither being, on the one hand, difficult to handle; nor, on the other, interfering with the clearness of the image formed by medium powers of moderate aperture, even when no special adjustment is made for the aberration they produce (§ 101).

118. The exact thickness of any piece of glass may be determined without difficulty, by placing it edgewise on the stage of the microscope (holding it in the stage-forceps), and measuring its edge by the eye-piece micrometer (§ 16). A much more ready means is afforded, however, by the *Lever of Contact* (Fig. 60)

FIG. 60.

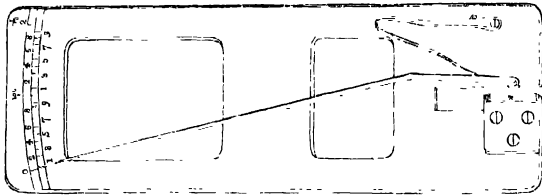

Lever of Contact.

devised by Mr. Ross for this express purpose. This instrument consists of a small horizontal table of brass, mounted upon a stand, and having at one end an arc graduated into 20 divisions, each of which represents 1-1000th of an inch, so that the entire arc measures 1-50th of an inch; at the other end is a pivot, on which moves a long and delicate lever of steel, whose extremity points to the graduated arc, whilst it has very near its pivot a sort of projecting tooth, which bears at * against a vertical plate of steel that is screwed to the horizontal table. The piece of thin glass to be measured, being inserted between the vertical plate and the projecting tooth of the lever, its thickness in thousandths of an inch is given by the number on the graduated arc, to which the extremity of the lever points. Thus, if the number be 8, the thickness of the glass is .008, or 1-125th, of an inch.—A very elegant little instrument, which is used by watchmakers for measuring the thickness of thin plates and wires, may be obtained at a much less cost from the dealers in Swiss tools; this answers the purpose equally well; but the 'value' of its scale must be determined by gauging the thickness of a piece of glass, or the diameter of a fine wire, and comparing the

number of divisions which it indicates, with the micrometrical measurement of the same body obtained by the microscope.—When the glass covers have been sorted according to their thickness, it will be found convenient to employ those of one particular thickness for each particular class of objects; since, when one object is being examined after another, no re-adjustment of the objective will then be required for each. This will be found a great saving of time and trouble, when high powers are in use.—It is undesirable to employ glass covers of greater thickness than 1-140th (007) of an inch, with any object-glass whose aperture exceeds 75° ; and for object-glasses of 120° and upwards, the glass cover should not exceed 1-250th (004) of an inch.

119. On account of the extreme brittleness of the thin glass, it is desirable to keep the pieces, when cut and sorted, in some fine and soft powder, such as starch. Before using it, however, the Microscopist should be careful to clean it thoroughly; not merely for the sake of removing foulnesses which would interfere with the view of the object, but also for the sake of getting rid of adherent starch-grains, the presence of which might lead to wrong conclusions, and also of freeing the surface from that slight greasiness, which, by preventing it from being readily wetted by water, frequently occasions great inconvenience in the mounting of objects in fluid. The thicker pieces may be washed and wiped without much danger of fracture, if due care be employed; but the thinner require much precaution; and in cleansing these, the simple method devised by Mr. Spencer will be found very useful. This consists in the use of a pair of round flat disks, about $1\frac{1}{2}$ inch in diameter, made of wood or metal covered with chamois leather, and furnished with handles; for when a piece even of the thinnest glass is laid upon one of these, it may be rubbed clean with the other, and any amount of pressure may be used, without the least risk of breaking it. Previously to doing this, however, it will be advantageous to soak the pieces for a time in strong sulphuric acid, and then to wash them in two or three waters; if greasiness, however, be their chief fault, they should be soaked in a strong infusion of nut-galls; with which it will be also advantageous to cleanse the surface of glass slides that are to be used for mounting objects in liquid.

120. *Varnishes and Cements.*—There are three very distinct purposes, for which cements that possess the power of holding firmly to glass, and of resisting, not merely water, but other preservative liquids, are required by the Microscopist; these

being (1) the attachment of the glass covers to the slides or cells containing the object, (2) the formation of thin cells of cement only, and (3) the attachment of the glass-plate or tube-cells to the slides. The two former of these purposes are answered by liquid cements or *varnishes*, which may be applied without heat; the last requires a *solid cement* of greater tenacity, which can only be used in the melted state.—The Varnishes used for mounting objects in liquid, should always be such as contain *no mixture of solid particles*. This is a principle on which the Author, from an experience of many years, is disposed to lay great stress; having often made trial, at the recommendation of friends, of varnishes which were said to have been greatly improved by thickening with • litharge or lamp-black; and having always found that, although they might stand well for a few weeks or months, they became porous after a greater lapse of time, allowing the evaporation of the liquid and the admission of air. He has himself found none more durable than that known as japper's *Gold-size*, which may be obtained at almost every colour-shop; for although this, when newly made, is apt to be somewhat too thin, so as to tend to *run-in* beneath the glass-cover, it may be easily thickened to any required degree, by keeping for some time in an open bottle. If it be allowed to become so thick, however, as not to be easily worked by the brush, it is quite unfit for use. There are few preservative liquids with which gold-size may not be employed; since it is not acted-on by any aqueous solution, and resists moderately-diluted spirit; oil of turpentine being its only true solvent.*—Many Microscopists prefer the solution of shell-lac in naphtha, which is sold under the name of *Liquid Glue*; this dries more quickly than gold-size, but is more brittle when completely hardened, and does not, in the Author's opinion, adhere so firmly and enduringly to glass; and it is, moreover, more easily acted-on by diluted alcohol than the preceding.—Of late, a solution of *Asphalte* in drying-oil or turpentine, sometimes known under the name of "*Brunswick-black*," has come much into use. It is extremely easy and pleasant to work-with, and dries quickly; but it is brittle when dry, and is disposed to crack, not merely when subject to any 'jar,' but also (after some time) spontaneously. This evil may be corrected, according to Mr. Brooke, by adding to it a little solution of Caoutchouc in

* The Author has preparations mounted with gold-size as much as twelve years ago, which have remained perfectly free from leakage; the precaution having been taken, to lay on a thin coat of varnish every two or three years.

mineral naphtha. Oil of turpentine is the solvent for this varnish, as for gold-size; and brushes which have been used with either, may be cleansed by that menstruum; those which have been used with liquid glue, may be cleansed with naphtha. —For mounting objects *dry* (§ 122), or for giving a finished appearance to mountings which have been made by one or other of the foregoing cements, varnishes may be used, which, from containing colouring particles, or from being acted-on by the preservative liquids employed, could not be safely laid-on in the first instance. Among the most convenient of this kind, are varnishes made by dissolving red or black or any other coloured *Sealing-wax* in strong alcohol; these are more to be recommended for their appearance, however, than for their tenacity, being very apt to lose their hold upon the glass after a time; and the Author, having suffered much injury to his preparations from trusting to them, would recommend that, even in mounting objects dry, some other cement should be first used, by which the glass cover should be attached to the slide, the sealing-wax varnish being only laid-on as a finish. If a black varnish be desired for such a purpose, it may be readily made by mixing gold-size with a small quantity of lamp-black; this dries quickly, and is free from brittleness; but, for the reason already mentioned, it should not be used in the first instance to mount objects in fluid, although it may be laid as a finish over gold-size or asphalt. —For making cement-cells (§ 134), either asphalt, gold-size, or liquid glue may be employed, the first being on the whole preferable; the varnish termed *Black Japan* also makes very good and durable cells, if the glasses to which it has been applied be exposed to the heat of an oven, not raised so high as to cause them to ‘blister.’

121. Although Canada balsam has been sometimes used as a cement, and has the advantage of being worked with extreme convenience, yet it is so apt to crack when hardened by time, that a slight ‘jar’ will cause the cell to spring-away from the glass to which it has been attached. Hence, if employed at all for affixing cells to glass-slides, its use should be limited to those plate-cells which afford a large surface of attachment (§ 136), or to those very thin tube-cells (§ 135), which cannot be so conveniently attached with marine glue, and of which the cover may be secured to the slide by spreading the ring of gold-size round the margin of the cell itself (§ 138). Care should be taken, in applying the Canada balsam, that it be sufficiently hardened by heat, but that it be not so heated as

to become brittle (§ 109): the general method of using it for this purpose, is the same as that which must be practised in the case of marine glue. The superfluous balsam left after pressing-down the cell, is to be removed, first by scraping with a heated knife, and then with a rag dipped in oil of turpentine, after which it is desirable to give the glass surface a final cleansing with alcohol.—For all kinds of cells (§§ 135 137) except those just mentioned, the proper cement is *Marine Glue*, which is a mixture of shell-lac, caoutchouc, and naphtha, now extensively employed; being distinguished by its extraordinary tenacity, and by its power of resisting solvents of almost every kind. Different qualities of this substance are made for the several purposes to which it is applied; that which is the most suitable to the wants of the Microscopist, is known in commerce as GK 4. As this cement can only be applied hot, and as it is a great saving of trouble to attach a considerable number of cells at the same time, a *Mounting-Plate* should be provided, which will furnish the requisite heat to several slides at once. Such a surface may be afforded by the top of a stove; but it is better to have one which can be used at all seasons, and the heat of which can be precisely regulated at pleasure. A very simple apparatus much used for this purpose, consists of a small table of brass- or iron-plate, about 6 inches long and 2 broad, with legs about 4 inches high, either screwed into its four corners, or so jointed to them as to fold-down; this is set over a small spirit-lamp, the flame of which is regulated to give the heat required. The Author has found it much preferable, however, to lay the plate on one of the rings of a small 'retort-stand' (used in Chemical operations), which admits of being shifted to any height that may be desired, so that the heat applied may be precisely graduated; or, if a gas-lamp be employed for the ordinary purposes of illumination, its stem may be fitted with a sliding-ring, which will carry either a hot plate or a water-bath.* It is more convenient, however, to have two such plates, laid on two rings; one being allowed to cool with the slides upon it, whilst the other is being heated.—The glass slides and cells which are to be attached to each other, must first be heated on the mounting-plate; and some small cuttings of marine-glue are then to be placed, either upon that surface of the cell which is to be attached, or upon that portion of the slide on which it is to lie, the former being perhaps preferable. When they

* Both these fittings are adapted to the Gas-lamp supplied for the use of Microscopists by Mr. S. Highley (§ 75).

begin to melt, they may be worked over the surface of attachment by means of a needle-point; and in this manner, the melted glue may be uniformly spread, care being taken to pick-out any of the small gritty particles which this cement sometimes contains. When the surface of attachment is thus completely covered with liquefied glue, the cell is to be taken-up with a pair of forceps, turned over and deposited in its proper place on the slide; and it is then to be firmly pressed-down with a stick (such as the handle of the needle) or with a piece of flat wood, so as to squeeze-out any superfluous glue from beneath. If any air-bubbles should be seen between the cell and the slide, these should if possible be got-rid-of by pressure, or by slightly moving the cell from side to side; but if their presence results, as is sometimes the case, from deficiency of cement at that point, the cell must be lifted-off again, and more glue applied at the required spot. Sometimes, in spite of care, the glue becomes hardened and blackened by overheating; and as, in this case, it will not stick well to the glass, it is preferable not to attempt to proceed, but to lift-off the cell from the slide, to let it cool, and then to repeat the process. When the cementing has been satisfactorily accomplished, the slides should be allowed to cool gradually, in order to secure the firm adhesion of the glue; and this is readily accomplished, in the first instance, by pushing each, as it is finished, towards one of the extremities of the plate, which is of course cooler than the centre. If two plates are in use, the heated plate may then be readily moved away upon the ring which supports it, the other being brought down in its place; and as the heated plate will be some little time in cooling, the firm attachment of the cells will be secured. If, on the other hand, there be only a single plate, and the operator desire to proceed at once in mounting more cells, the slides already completed should be carefully removed from it, and laid upon a *wooden* surface, the slow conduction of which will prevent them from cooling too fast. Before they are quite cold, the superfluous glue should be scraped from the glass with a small chisel or awl; and the surface should then be carefully cleansed with a solution of potash, which may be rubbed upon it with a piece of rag covering a stick shaped like a chisel. The cells should next be washed with a hard brush and soap-and-water, and may be finally cleansed by rubbing with a little weak spirit and a soft cloth. In cases in which *appearance* is not of much consequence, and especially in those in which the cell is to be used for mounting

large opaque objects, it is decidedly preferable not to scrape-off the glue too closely round the edges of attachment, as the 'hold' is much firmer, and the probability of the penetration of air or fluid much less, if the immediate margin of glue be left, both outside and inside the cell.

122. *Mounting Objects Dry.*—There are certain objects, which, even when they are to be viewed by *transmitted* light, are more advantageously seen when simply laid on glass, than when they are immersed either in fluid or in balsam. This is the case especially with sections of bones and teeth, much of whose internal structure is obliterated by the penetration of fluid; and also with the scales of Lepidopterous and other Insects, whose minute surface-markings are far more distinct when thus examined, than when treated in any other way.* For preserving such objects, it is of course desirable that they should be protected by a cover; and this must be so attached to the glass slide, as to keep the object in place, besides being itself secured. For this purpose, sealing-wax varnish is often used, but is unsuitable on account of its brittleness when dry; gold-size mixed with lamp-black is much to be preferred, and, if carefully laid-on, will not tend to run-in between the cover and the slide. If the object have any tendency to curl-up, or to keep-off the cover from the slide by its own 'spring,' it will be useful, while applying the varnish, to make use of pressure, such as that afforded by the little implement represented in Fig. 62. This pressure should not be remitted, until the varnish is dry enough to hold-down the cover by itself. For mounting delicate objects, the *thinner* slides should be selected (§ 116); and for very difficult test-objects, it is advantageous to employ thin-glass below as well as above the specimens, for the sake of diminishing the aberration which the illuminating pencil sustains in its passage to the object, and for allowing the achromatic condenser to approach the object as closely as possible. For this purpose, the simplest method is to take a slip of wood, of the ordinary

* It is affirmed by two high authorities on all that relates both to the theoretical and practical action of Object-glasses of large aperture (namely, Prof. Robinson and Mr. Wenham), that the effect of mounting delicate test-objects in Canada-balsam is practically to reduce the aperture, since no rays can diverge after passing through a stratum of this substance, at a greater angle than 86° or 90° . Hence they recommend that the 'difficult' *Diatomaceæ* should *not* be mounted in balsam, if they are to be viewed by objectives of 120° or 130° . Their position is disputed, however, by Prof. Bailey (U.S.), who affirms that balsam-mounted specimens are preferable as test-objects.—Those who are interested in this question, will do well to consult the papers of these gentlemen, in the 2nd and 3rd volumes of the "Quart. Journ. of Microsc. Science."

size of the glass slide (3 in. by 1 in.), with a central aperture of from 3 to 5-8ths of an inch; to cover this aperture with a 'square' or 'round' of thin glass of sufficient size to project considerably beyond it; to lay the object upon this glass, and to protect it with a cover of rather smaller size, which should be fastened-down all round by varnish, to prevent the entrance of moisture; and finally to secure both glasses to the wooden slide, by gumming-down over them a piece of paper, with a perforation of the same size as that of the slide itself.

123. For dry-mounting *opaque* objects, the method adopted must vary with the mode in which the object is to be illuminated; since, if a side-condenser or reflector is to be employed, the whole slide may be opaque; whereas if the Lieberkuhn is preferred, the object should be placed on a disk of appropriate size (§ 65), supported in such a mode as to admit the light all around it.—For the former purpose, the Author has devised the following simple method, which he has found to afford peculiar conveniences. Let there be provided a cedar-slide of the kind just described, a piece of card of the same dimensions, and a piece of *dead-black* paper, rather larger than the aperture of the slide, if a dark mounting be desired, which is preferable for most objects: this piece of paper is to be gummed to the middle of the card, and then, some stiff gum having been previously spread over one side of the slide (care being taken that there is no superfluity of it immediately around the aperture), this is to be laid-down upon the card, and subjected to pressure.* An extremely neat 'cell' will thus be formed for the reception of the object, the depth of which will be determined by the thickness of the slide, and the diameter by the size of the perforation; and it will be found convenient to use slides of various thicknesses and having apertures of different sizes. The cell should always be deep enough for its wall to rise above the object; but, on the other hand, if it be too deep, its wall will interfere with the oblique incidence of the light upon any object that may be near its periphery. The object, if flat or small, may be attached by ordinary gum-mucilage; if, however, it be large, and the part of it to be attached have an irregular surface, it is desirable to afford a 'bed' to this by gum thickened with starch. The complete protection thus given to the object, is the great recommendation of this method; since, when

* It will be found a very convenient plan, to prepare a large number of such slides at once and this may be done in a marvellously short time, if the slips of card have been previously cut to the exact size in a bookbinder's press.

objects are simply fastened on black paper gummed on a slip of glass, their projection from its surface renders them constantly liable to accidents; as many know, to their cost, who have used that mode of mounting. But this is by no means its only convenience. It is far cheaper than mounting objects in glass cells, which is the only other mode of affording them protection, save the use of pill-boxes in the manner to be presently described. It allows the slides, not only to range in the ordinary cabinets, but also to be laid one against another, and to be packed closely in cases or secured by elastic bands; and this last plan is extremely convenient, not merely for the saving of space, but also for preserving the objects from dust. Should any more special protection be required, a thin-glass cover may be laid over the top of the cell, and secured there by gummed paper; but this will, of course, occasion a slight projection, which will expose the glass cover to the risk of fracture when the slide is pressed against others; and the Author's experience leads him to conclude, that the mode of packing just described affords a security from dust, that is scarcely less effectual than a thin-glass cover. Further, the card on the under surface affords a great convenience for writing on the slide the name and other particulars of the object. If the object be so large as to project above the surface, even when the thickest slides are used which it is convenient to employ, an additional protection may be afforded, by gluing a couple of strips of wood of adequate thickness along the edges of the slide;* or by gumming a second slide to the face of the first, taking care that its aperture be large enough to prevent obstruction to oblique light.—Very delicate flat objects, on the other hand, even when to be viewed by incident light, should be mounted on glass and protected by a cover, in the same manner as transparent objects; a dark back-ground being furnished to them, either by the 'dark well' (§ 65) or by the closed diaphragm (§ 55).

12 $\frac{1}{2}$. Objects which are to be viewed by the Lieberkuhn,

* A very convenient kind of slide, for mounting large opaque objects, is made by Messrs Carpenter and Westley, 24, Regent-street, by ploughing-out a groove in a strip of wood, so that its section presents this form . The object may be mounted upon the bottom of the groove; or upon a disk of card fitted into an aperture in the slide, and so held there by a brass ring, that it may be taken-out and held between the stage-forceps, so as to be viewed with the Lieberkuhn. These slides are commonly made five inches long, and are fitted for the reception of four objects; for the sake of uniformity, however, as well as for preventing them from overbalancing on the stage, it might be convenient that they should be made three inches long, and that each should only receive one or (at most) two objects.

should be mounted either on flat disks of card or cork, or, if protection be desired, in cups of proper depth, resembling very shallow pill-boxes, which may be made, with or without covers,* of any size desired, and lined with black paper, by any pill-box maker. The disks or pill-box-cells may be attached to glass slides by gum, so as to range in an ordinary object-cabinet; and this mode will be generally adopted by such as lay stress upon uniformity, and prefer the easiest methods of exhibiting their objects. As there are many opaque objects, however, which can only be well judged-of when different sides are presented to the Microscope, there is a great advantage in mounting these in such a manner, as to admit of their being turned at various angles; and this may be done by attaching the disk with sealing-wax or some other cement, to a pin, which may be either held between the blades of the stage-forceps, or passed into the cork-box at its other extremity (§ 66). If the Microscopist should be pursuing the study of any class of objects which renders it desirable to mount a large number in this mode, the most convenient plan is to glue two pieces of cardboard to the two sides of a piece of rather thick chamois leather; one of the surfaces of this sandwich-like board should be covered with dead-black paper; and disks of any desired diameter may then be cut-out with a punch, and mounted upon a pin by simply passing it through the stratum of leather. The pill-box mounting will be less advantageous for this purpose, since, if the object be completely buried in the cell, there will be less power of seeing it on any but its upper surface; a pin may be secured to the bottom of such a box, however, by gumming over it a piece of stout paper. Disks may easily be punched, also, out of sheet-gutta-percha of any convenient thickness; or short cylinders may be made, by cutting-up the thick cords made for lathe-bands; these are all readily penetrated by a heated pin, and no further trouble is necessary to attach them to it. Protective wells may also be made by cutting-off short pieces from a gutta-percha tube, and attaching these to the disks by a gentle heat.—For the reception of boxes or disks

* Round boxes with glass covers are now coming into very extensive use for the preservation of Natural-History specimens of various kinds, in such a manner that the contents of each box whilst protected and kept-together, are at the same time presented to the eye. The Author has found the smallest and shallowest boxes of this kind that can be made, especially when lined with black paper, extremely useful for keeping Foraminifera and other Microscopic organisms in quantities, and also for mounting larger specimens for the Microscope as above described.

thus mounted on pins, a drawer should be provided with a thick cork bottom, into which the pin is to be inserted far enough to prevent risk of displacement.

125. *Mounting Objects in Canada Balsam.*—This method of mounting is suitable to a very large proportion of those objects, which are to be viewed by transmitted light, and whose texture is not affected by the loss of the aqueous fluid they may contain; and it has many advantages over the mounting of the like objects dry. For, in the first place, as it fills-up the little inequalities of their surface, even where it does not actually penetrate their substance, it increases their transparency by doing-away-with irregular refractions of the light in its way through them, and gives them the aspect of perfect smoothness; this is well seen in the case of sections of *Shell*, &c., which, when thus mounted, do not require a high polish (§ 110). But, secondly, where the structure, although itself hard, is penetrated by internal vacuities, the balsam, by filling these, prevents that obscuration resulting from the interposition of air-spaces, and from additional internal surfaces of reflection, by which the transmitted rays are distorted, and a large proportion of them lost: this is well seen in the case of the *Foraminifera*, and of sections of the ‘test’ and ‘spines’ of *Echinida*, whose intimate structure can be far better made-out, when they are thus mounted, than when mounted dry, although their substance is (for the most part at least) itself so dense, that the balsam cannot be imagined to penetrate it; and likewise with dry *Vegetable* preparations, which are perhaps also affected in the manner to be next described. Thirdly, there are very many structures of great interest to the Microscopist, whose appearance is extraordinarily improved by this method of mounting, in consequence of a specific effect which the balsam has in combining (so to speak) with their component elements, so as to render them far more transparent than before: this effect is seen in the case of all dry preparations of *Insect*-structure, especially of such as consist of their hard external tegument or of parts derived from this; also in the various *horny* tissues (hairs, hoof, horn, &c.) of the higher animals; and likewise in many organised substances, both recent and fossil, which are penetrated by calcareous matter in an *amorphous* condition.—Besides these advantages, the mounting of objects in Canada balsam affords one of the easiest methods of fixing and preserving them; and consequently, it is almost always had recourse-to, in the case of such transparent objects as do not need to be preserved in fluid; save where, in virtue

of the action just described, it impairs the distinctness of surface-markings, or obliterates internal cavities or canals, which constitute the most important features of the object.

126. Canada Balsam, being nothing else than a very pure *Turpentine*, is a natural combination of resin with the essential oil of turpentine. In its fresh state, it is a viscid liquid, easily poured-out, but capable of being drawn into fine threads; and this is the condition in which the Microscopist will find it most desirable to use it for the mounting of objects generally. The balsam may be conveniently kept in a glass bottle or jar with a wide mouth, being taken-up as required by a small glass rod drawn to a blunt point, such as is used by Chemists as a 'stirrer;' and if, instead of a cork or stopper, this bottle should be provided with a tall hollow 'cap,' the glass rod may always stand in the balsam, with its upper end projecting into the cap. In taking-out the balsam, care should be taken not to drop it prematurely from the rod; and not to let it come into contact with the interior of the neck or with the mouth of the jar. Both these mischances may be avoided, by not attempting to take-up on the rod more than it will properly carry; and by holding it in a horizontal position, after drawing it out from the bottle, until the slip on which it is to deposit the balsam, is just beneath its point. The Author has himself been in the habit of employing, instead of a hollow cap to his balsam-jar, a disk of light wood, simply lying on its mouth; the centre of this disk is perforated with a hole, just large enough to allow the glass rod to fit it rather stiffly; and the rod is to be passed into the jar, only so far as to dip by its point into the balsam, being pushed further down as the level of the balsam is lowered. In this manner, a small quantity of balsam may be taken-up with far less risk of *messing* it, than when the rod dips into it for two or three inches; if due care be taken not to allow the balsam to come into contact with the lip of the jar, the cover never sticks to it, but is readily lifted-off upon the rod; and although it might seem an incumbrance in the use of the rod, yet it is not practically found to be so.—If the balsam be kept too long, it becomes, through the loss of part of its volatile oil, too stiff for convenient use, and may be thinned by mixing it at a gentle heat with pure oil of turpentine; this mixture, however, does not produce that thorough incorporation of the constituents which exists in the fresh balsam; and it is consequently preferable to use in other ways the balsam which has become somewhat too stiff, and to have recourse to a fresh

supply of liquid balsam for mounting-purposes.—When Canada balsam is to be employed as a *cement*, as for attaching sections, &c., to glass-slides (§ 109), it should be in a much stiffer condition; since, if it be dropped on the slide in too liquid a state, it will probably spread much wider, and will lie in a thinner stratum, than is desirable. This hardening process may be carried to any extent that may be desired, by exposing the balsam in an uncorked jar (the mouth of which, however, should be covered with paper, for the sake of keeping-off dust) to a continual gentle heat, such as that of a water-bath.

127. In mounting objects in Canada balsam, it is convenient to be provided with certain simple instruments, the use of which will save much time and trouble.—For the heat required, a Spirit-lamp is by far the best source; both as admitting of easy regulation, and as being perfectly free from smoke.—Where a number of objects are being mounted on the same occasion, it will be found convenient to employ either a water-bath covered with a flat plate of metal, or a similar metal plate supported at such a distance above the lamp-flame (§ 121), as not to become more heated than it would be through a water-bath.—For holding the slide, either whilst it is being heated over the flame, or whilst it is being subsequently cooled, the Wooden Forceps (Fig. 61) contrived for

FIG. 61.



Slider-Forceps.

this purpose by Mr. Page, will be found extremely convenient; this, by its elasticity, affords a secure grasp to a slide of any ordinary thickness, the wooden blades being separated by pressure upon the brass studs; and the lower stud, with the bent piece of brass at the junction of the blades, affords a level support to the forceps, which thus, while resting upon the table, keeps the heated glass from contact with its surface.—Besides a pair of fine-pointed Metal-forceps for holding the object to be mounted, there should be another of a commoner kind for taking-up the glass cover, the former being liable to be soiled with balsam.—A pair of stout needles mounted in wooden handles (§ 105), will be found indispensable, both for

manipulating the object, and for breaking or removing air-bubbles; and if these handles be cut to a flat surface at the other extremity, they will serve also to press-down the glass covers, for which purpose, a pointed stick also is useful.—For holding-down these covers, whilst the balsam is cooling, if the elasticity of the objects should tend to make them spring-up, nothing is more simple or convenient than a compressor made by a slight alteration of the ‘American clothes-peg,’ which is now in general use in this country for a variety of purposes; all that is necessary being to rub-down the opposed surfaces of the ‘clip’ with a flat-file, so that they shall be parallel to each other when an ordinary slide with its cover is interposed between them (Fig. 62).—Great care should be taken to keep these implements free from soils of balsam; since the slides and glass-covers are certain to receive them. The readiest mode of cleansing the needles (their ‘temper’ being a matter of no consequence for these

FIG. 62.

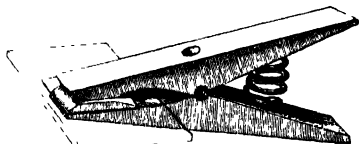

Spring-Press.

purposes) is to heat them red-hot in the lamp, so as to burn-off the balsam; and then carefully to wipe them. The forceps, both of wood and of metal, should be cleansed with oil of turpentine or with rectified spirit.

128. Much of the success of mounting objects in this mode will depend upon their previous preparation. They should have been previously well cleansed with water, from which they should be transferred into proof-spirit, as this will dry-out much more readily than water. If they have any greasiness of surface or of substance, this should be removed by maceration in ether or in oil of turpentine; and maceration in turpentine is also very useful in preparing the way for the penetration of the balsam into substances which are unusually opaque. A long-continued maceration in turpentine, moreover, assists in freeing the specimen from air-bubbles; as it gradually creeps into spaces which are otherwise unoccupied, and, when the object is transferred to the balsam, the free miscibility of the two substances causes its place to be partly taken by the latter.—In mounting an ordinary object, a sufficient quantity of liquid balsam should be laid in the

centre of the slide; this should be warmed, but not boiled; and any air-bubbles which may make their appearance, should either be caused to burst by touching them with the needle-point, or should be drawn to one side. The object, if it can be held in the fine-pointed forceps, should then be plunged into the drop of balsam; and, if it be not completely covered, a little more balsam should be applied over it, care being taken as before to prevent over-heating, and to get-rid of the bubbles as they rise. If, on the other hand, the object be in a finely-divided condition (such, for example, as a collection of fossil Infusoria, of Sponge-spicules, &c.), it is better to place it first in the position it is to occupy on the slide, then to place near it a drop of balsam, which is to be warmed and freed from bubbles as before; the slide is then to be so inclined, as to cause the balsam to run towards the object, through and over which it will probably diffuse itself without any air-bubbles; but if any should arise, they may be broken by a heated needle-point.—If the object contain numerous large air-spaces with free openings, and be one whose texture is not injured by heat, as is the case with Foraminifera, the air may often be got-rid-of by boiling it in the balsam; for the heat, causing the air to expand, drives-out a large proportion of it; this will be replaced, if it be allowed partly to cool, by the entrance of balsam; and then, by a second heating, the balsam being boiled within the cavities, its vapour expels the remaining air, and, on the condensation of the vapour, the liquid balsam runs-in and takes its place. For this method to succeed, however, it is essential that the balsam be prevented from becoming hard through boiling, by the addition of fresh liquid balsam from time to time; and it will often be found that, should vacuities remain which boiling does not remove, these contract or altogether disappear if the slide be kept for a few days at a gentle heat, the semi-fluid balsam being gradually forced into their place by the pressure of the surrounding air. There are many textures, however, which are extremely injured by a very slight excess of heat, having a tendency to curl-up and to become stiff and brittle; and objects containing these are at once spoiled by boiling them in balsam. In such cases, it is much better to have recourse to the assistance of the air-pump; for by placing the slide, with the object immersed in very liquid balsam, upon a tin or copper vessel filled with hot water, under the receiver, and then exhausting this, the air-bubbles will be drawn-forth, and, on the re-admission of the

air, the balsam is forced by its pressure into the place which they occupied. Some objects, however, retain the air with such tenacity, as to require the repetition of the exhausting process two or three times; and in this case it is preferable to use camphine or oil of turpentine instead of balsam, on account of its greater fluidity, and to warm even this to a temperature of about 100°.—There are certain cases, on the other hand, in which it is desirable to retain, instead of expelling, the air contained within the cavities of the object. Thus, if minute insects (such as Flies) be displayed as transparent objects to show the ramifications of the tracheæ, or if it be wished that a section of Tooth or Bone should be so mounted in balsam, as to exhibit its canaliculi, the previous maceration in oil of turpentine should be never employed, and the balsam employed should be some which has been previously hardened; this being melted without the use of more heat than is necessary, the object should be surrounded by it, and the cover put-on as quickly as possible; and the slide should then be laid upon a surface of stone or metal, the good conducting power of which causes the balsam to cool rapidly, and thus diminishes its tendency to penetrate into the substance of the object.

129. When the object is already attached to the glass slide, the mounting in Canada balsam is usually a matter of very little difficulty. If it be a soft tissue which has been spread-out and allowed to dry upon the glass for the purpose of securing it in its place, all that is necessary in the first instance is to dry it thoroughly, to shave or scrape it with a sharp knife if it should seem too thick, and to moisten its surface with oil of turpentine if it should not readily 'take' the balsam. The slide is then very gently warmed, a sufficient quantity of balsam is spread over the surface of the specimen, care being taken that it 'takes' it in every point, and the glass cover is put-on. If the preparation cover a large area, great care should be taken in letting-down the cover *gradually* from one side, so as to drive a wave of balsam before it which shall sweep-away air-bubbles; raising it a little, and introducing a small quantity of fresh balsam, if any vacuity present itself as it descends.—The preferable mode, however, of mounting thin sections of hard bodies, will depend in great degree upon the size of the section and the tenacity of its substance. Where its area is great and its texture brittle, its removal from the glass on which it has been ground-down, to another slip, cannot be accomplished, even

by the most dexterous management, without considerable risk of breaking it; and although, by the friction of the glass upon the stone, the edges of this will probably have been scratched or roughened, yet this is a dis-sight about which the scientific Microscopist will care but little, as it only affects the saleable value of such objects. Nothing more will in this case be necessary, than to lay some liquid Canada balsam on the surface of the section, to warm it gently, and then to place on it a thin-glass-cover of suitable dimensions, gently pressing this down wherever the balsam happens to be thickest, and endeavouring to drive all air-bubbles before a wave of liquid, until they are entirely expelled, or at any rate are driven beyond the margin of the section. If this operation be not at once successful,—either a few large air-bubbles, or a great number of smaller ones, which cannot be got-rid-of by gentle pressure, being visible between the surface of the section and the covering-glass,—it is better at once to remove the cover by gentle warmth, and to repeat the operation with an additional supply of balsam, rather than to attempt to drive-out the bubbles by any manipulation. Whatever treatment be adopted, special care should always be taken not to apply so much heat as to *melt* the hard balsam *beneath* the section,* or to *boil* the thin balsam *above*; in the former case, the loosening of the section from the glass is very apt to be followed by the detachment of some portions of it from the rest, whilst the glass cover is being pressed-down; and in the latter, the production of bubbles very seriously embarrasses the operation. If the heat should unfortunately be carried so far as to *boil* the cement *beneath* the section, there will be little chance, if its area be large, of getting-rid of the bubbles thus produced, without removing it altogether from the glass to which it was attached, or, at any rate, without pushing it along the glass, in such a way as to slide it away from the bubbles; in that case, the part towards which it is moved should always be well supplied with balsam, and the bubbles that remain should be drawn-away or broken with the needle-point; after which, the section being slid-back to its original position, it is probable that no bubbles may be found beneath it.—In cases, however, in which the *appearance* of the

* It will often be found convenient to turn the slide with the face downwards, and to apply a gentle heat directly to the thin-glass *cover*, and to the balsam *above* the object, instead of heating this through the glass *slide* and the balsam *beneath* it.

preparations is an object of much consideration, and in which the tenacity of the substance and the small size of the section prevent much risk of its breaking in the transfer, it may be loosened from the glass to which it was first attached, either by heat, or by soaking in ether. The former, being the simplest and readiest method, is the one most commonly practised; the only difficulty lies in lifting-off the specimen without breaking it; and this may best be done, by means of a camel-hair brush dipped in oil of turpentine. The glass to which the section is to be transferred, should have a large spot of liquid balsam laid in the proper place; the object is to be laid on this, and its upper surface covered with the like balsam; and then, the thin-glass-cover being placed upon it, this is to be gently pressed-down in the manner already described. If ether be had-recourse-to, the slide should be placed in a wide-mouthed bottle of that liquid, which should then be corked or stopped; and after a time, the section will be found to be lying detached in it, whence it may be taken-up either by the forceps or camel-hair brush.—Such a transfer will often be found advantageous, before the final completion of the reducing-process; for it will occasionally happen that we find something in the structure of the specimen, which will be best displayed by rubbing it down afresh on the side first attached to the glass; and, when a number of small sections are being made at once (which it is often very convenient to do, not only in the case already mentioned, § 108, but in many others), it not only saves time, but ensures the accurate flattening of the surface in grinding, to fix several upon the same slip, and to work them down together, until the requisite thinness has been nearly attained, when they must be transferred to separate slips, and finished one by one. In either case, the re-attachment must of course be made, like the original attachment, with balsam which has been first hardened (§ 109).

130. When the Balsam employed in mounting has remained in the liquid condition here recommended, the glass cover will not be secure from displacement until the balsam has become harder. This change it will require a long time to undergo, unless the aid of a gentle continuous warmth be afforded. Nothing is more suitable for this purpose, than the warmth of a chimney-piece immediately above the fire-place; as it is quite sufficient to produce the effect in the course of a few days, whilst there is no danger of its becoming excessive; but

in default of this convenience, an oven carefully regulated, or (still better) a water-bath, may be employed. Whether either of these means be adopted, or the slides be put aside for the balsam to be hardened by time, they should always be laid in the *horizontal* position, that their covers may not be caused by gravitation to slip-down from their places.—It may be better, before submitting the slides to this hardening process, to scrape from their surface any superfluous balsam that does not immediately surround the glass-cover; but the knife should never be carried so near to the edge of this, as to run any risk of displacing it; and it is much better to defer the final cleaning of the slide, until the attachment of the cover has become firm. The remaining balsam may then be scraped-away with a knife or small chisel, the implement being warmed if the balsam be very stiff; the slide should then be rubbed with a rag dipped in oil of turpentine, until every perceptible soil of balsam is removed, especial care being taken to cleanse the surface and edges of the glass-cover; and as this will itself leave a certain resinous film, it is better to give the slide a final cleansing with Alcohol. If its surface should have been considerably smeared with balsam, it is very convenient, after scraping away all that can be removed in that manner, to scrub it with a tooth-brush or nail-brush, first letting-fall on it a few drops of turpentine or spirit of wine; and there is less risk of displacing the glass cover in this mode, than in rubbing it in any other way.—The menstrua which serve thus to cleanse the slides, of course answer equally well for cleansing the hands. The most ready solvent for balsam is Ether; but the ordinary use of this being interdicted by its costliness, and by the quickness with which it is dissipated by evaporation, Alcohol or Oil of Turpentine may be used in its stead.

131. *Preservative Fluids*.—Objects which would lose their characters in drying, can of course only be preserved in anything like their original condition, by mounting in fluid; and the choice of the fluid to be employed in each case, will depend upon the character of the object, and the purpose aimed-at in its preservation. As specific directions will be given hereafter in regard to most of the principal classes of Microscopic preparations, little more will be required in this place, than an enumeration of the preservative fluids, with a notice of their respective qualities.—For very minute and delicate Vegetable objects, especially those belonging to the orders Desmidiaceæ

and Diatomaceæ, nothing seems to produce less alteration in the disposition of the endochrome, or serves better to preserve their colour, than *Distilled Water*; provided that, by the complete exclusion of air, the vital processes and decomposing changes can be alike suspended. This method of mounting, however, is liable to the objection that confervoid growths sometimes make their appearance in the preparation; and it is preferable to make some addition to the water, which shall be unfavourable to their development. Saturation with *camphor*, or shaking-up with a few drops of *creasote*, will sometimes answer; but if the preservation of colour be not an object, nothing is better than the addition of about a tenth part of *alcohol*; and where the loss of colour would be objectionable, the solution of a grain of bay-salt and a grain of alum in an ounce of water will give it the requisite qualities.—For larger preparations of *Algæ*, &c., what is called *Thwaites's Fluid* may be employed; this is prepared by adding to one part of rectified spirit as many drops of *creasote* as will saturate it, and then gradually mixing up with it in a pestle and mortar some prepared chalk with 16 parts of water; an equal quantity of water saturated with *camphor* is then to be added, and the mixture, after standing for a few days, is to be carefully filtered. A liquid of this kind also serves well for the preservation of many animal preparations; but it is said by Dr. Beale to become turbid when thus employed in large quantity; and he recommends the following modification. Mix 3 drachms of *creasote* with 6 ounces of wood naphtha, and add in a mortar as much prepared chalk as may be necessary to form a smooth thick paste; water must be gradually added to the extent of 64 ounces, a few lumps of *camphor* thrown-in, and the mixture allowed to stand for two or three weeks in a lightly-covered vessel, with occasional stirring; after which it should be filtered, and preserved in well-stopped bottles.—Of late years, *Glycerine* has been much employed as a preservative fluid; it allows the colours of vegetable substances to be retained, but, unless much diluted, it alters the disposition of the endochrome; and confervoid growths are apt to make their appearance in it. The best proportion seems to be one part of *glycerine* to two parts of *camphor-water*.—The preparation known as *Deane's Gelatine* is one of the most convenient media for preserving the larger forms of *Confervæ* and other *Microscopic Algæ*, as well as sections of such as are still more bulky. This is prepared by

soaking 1 oz. of gelatine in 4 oz. of water until the gelatine is quite soft, and then adding 5 oz. of honey previously raised to boiling heat in another vessel; the whole is then to be made boiling hot, and when it has somewhat cooled, but is still perfectly fluid, 6 drops of creasote and $\frac{1}{2}$ oz. of spirit of wine, previously mixed together, are to be added, and the whole is to be filtered through fine flannel. This composition, when cold, forms a very stiff jelly; but it becomes perfectly fluid on the application of a very slight warmth, and may then be used like any other preservative liquid, care being taken, however, that the slide and the glass-cover are themselves gently warmed before it comes into contact with them. A mixture of gelatine and glycerine has been employed for the same purpose.—Some Vegetable Anatomists make great use of a solution of *Chloride of Calcium* (muriate of lime) in three parts of water; its chief advantage being, that, owing to its deliquescent property, it does not dry-up, even when the cell is not perfectly closed-in. It has, however, the disadvantages of not preserving colours, and of altering the disposition of the cell-contents by its endosmotic power.—For the preservation of microscopic preparations of *Animal* tissues, a mixture of one part of Alcohol and five of water will generally answer very well, save in regard to the removal of their colours. Where the preservation of these is aimed-at, the best medium will usually be *Goadby's Solution*, which is made by dissolving 4 oz. of bay salt, 2 oz. of alum, and 4 grains of corrosive sublimate, in 4 pints of boiling water; this should be carefully filtered before it is used; and for all delicate preparations it may be diluted with an equal bulk, or even with twice its bulk, of water. This solution must not be used where any calcareous texture, such as shell or bone, forms part of the preparation; and one of Mr. Goadby's other solutions (8 oz. of bay salt and 2 grs. of corrosive sublimate, to a quart of water,—or, in cases where the coagulating action of corrosive sublimate on albuminous matters would be an objection, the substitution of 20 grains of arsenious acid,) may be used in its stead; or Thwaites's fluid, or Dr. Beale's modification of it, or Deane's Gelatine may be tried.—It is often quite impossible to predicate beforehand what preservative fluid will answer best for a particular kind of preparation; and it is consequently desirable, where there is no lack of material, always to mount the same object in two or three different ways, marking on each slide the method employed, and comparing the specimens from time to time, so as to judge how each is affected.

132. *Of Mounting Objects in Fluid.*—As a general rule, it is desirable that objects which are to be mounted in fluid, should be soaked in the particular fluid to be employed, for some little time before mounting; since, if this precaution be not taken, air-bubbles are very apt to present themselves. It is sometimes necessary, in order to secure the displacement of air contained in the specimen, to employ the air-pump in the mode already directed (§ 128); but it will sometimes be found sufficient to immerse the specimen for a few minutes in alcohol (provided that this does not do any detriment to its tissues), which will often penetrate where water will not make its way; and when the spirit has driven-out the air, the specimen may be removed-back to water, which will gradually displace the spirit. When Deane's gelatine is used, however, all that can be done, will be to drain the object of its superfluous water before applying the liquefied medium; but as air-bubbles are extremely apt to arise, they must be removed by means of the air-pump, the gelatine being kept in a liquid state by the use of a vessel of hot-water, as in the case of Canada balsam. In dealing with the small quantities of fluid required in mounting microscopic objects, it is essential for the operator to be provided with the means of transferring very small quantities from the vessel containing it, to the slide, as well as of taking-up from the slide what may be lying superfluous upon it. The straight and curved-pointed 'dipping-tubes' (Fig. 51, A, B) may be made to answer this purpose; but it is much better that tubes for this purpose be furnished with a bulb, like that of the Chemist's 'pipette,' and that their orifices be drawn to a fine point. The fluid is drawn into the tubes by suction, and expelled by the pressure of the breath; the curved-pointed tube will generally be the best for introducing fluid beneath the glass-cover, and the straight-pointed for simply filling cells or for taking-up superfluous fluid. The Author has of late found very great convenience in the use of a small glass syringe, the orifice of which is slightly curved and drawn to a fine capillary point; for as the syringe works independently of the mouth, its orifice may be applied in any way that may be found convenient; and when the mouth is freed from the efforts of suction and ejection, the eyes can be better employed in watching the operation.—Besides the pipettes and the syringe, some blotting-paper, of the most bibulous kind that can be procured, will be found very useful.

133. There are certain objects of extreme thinness, which

require no other provision for mounting them in fluid, than an ordinary glass slide, a thin-glass cover, and some gold-size or asphaltic (§ 120). The object having been laid in its place, and a drop of the fluid laid upon it (care being taken that no air-space remains beneath the under side of the object and the surface of the slide), the glass cover is then to be laid upon it, one side being first brought into contact with the slide, and the other being gradually lowered, in such a manner that the air shall be all displaced before the fluid. If any air-bubbles remain in the central part of the space between the cover and the slide, the former must be raised again, and more fluid should be introduced; but if the bubbles be near the edge, a slight pressure on that part of the cover will often suffice to expel them, or the cover may be a little shifted so as to bring them to its edge. There are some objects, however, whose parts are liable to be displaced by the slightest shifting of this kind; and it is more easy to avoid making air-bubbles, by watching the extension of the fluid as the cover is lowered, and by introducing an additional supply when and where it may be needed, than it is to get rid of them afterwards without injury to the object. When this end has been satisfactorily accomplished, all that is needed is, first to remove all superfluous fluid from the surface of the slide, and from *around* the edge of the cover, with a piece of blotting-paper, taking care not to draw-away any of the fluid from *beneath* the cover, or (if any have been removed accidentally) to replace what may be deficient; and then to make a circle of asphaltic or gold-size around the cover, taking care that it 'wets' its edges, and advances a little way upon its upper surface. When this first coat is dry, another should be applied, particular care being taken that the cement shall fill the angular furrow at the margin of the cover. In laying-on the second coat, it will be convenient, if the cover be round, to make use of the whirling-table (Fig. 63); and if the slide be so carefully laid upon it, that the glass-cover is exactly concentric with its axis, the whirling-table may be used even for the first application of the varnish; a slight error in this respect, however, may occasion the displacement of the cover.—By far the greater number of preparations which are to be preserved in liquid, however, should be mounted in a 'Cell' of some kind, which forms a *well* of suitable depth, wherein the preservative liquid may be retained. This is *absolutely necessary* in the case of all objects, whose thickness is such as to prevent the glass

cover from coming into close approximation with the slide; and it is *desirable*, wherever that approximation is not such as to cause the cover to be drawn to the glass slide by capillary attraction, or wherever the cover is *sensibly* kept apart from the slide by the thickness of any portion of the object. Hence it is only in the case of objects of the most extreme tenuity, that the 'cell' can be advantageously dispensed-with; —the danger of *not* employing it, in many cases in which there is no difficulty in mounting the object without it, being that after a time the cement is apt to run-in beneath the cover, which process is pretty sure to continue, when it may have once commenced.

134. *Cement-Cells*. — When the Cells are required for mounting very thin objects, they may be advantageously made of varnish only, by the use of the ingenious little instrument (Fig. 63) contrived by Mr. Shadbolt. This consists of a small

FIG. 63.



Shadbolt's Turn-table for making Cement-Cells.

slab of mahogany, into one end of which is fixed a pivot, whereon a circular turn-table of brass, about three inches in diameter, is made to rotate easily, a rapid motion being given to it by the application of the fore-finger to the milled-head seen beneath. The glass slide being laid upon the turn-table, in such a manner that its two edges shall be equidistant from the centre (a guide to which is afforded by a circle of an inch in diameter, traced upon the brass), and being held by the springs with which it is furnished, a camel-hair pencil dipped in the varnish to be used (Brunswick-black or Asphalte is the best) is held in the right hand, so that its point comes into contact with the glass, a little within the guiding circle just named. The turn-table being then put into rotation with the left hand, a ring of varnish of a suitable breadth is made upon the glass; and if the slide be set-aside in a horizontal position,

this ring will be found, when dry, to have lost the little inequalities it may have at first presented, and to present a very level surface. If a greater thickness be desired than a single application will conveniently make, a second layer may be laid-on after the first is dry. It is convenient to prepare a number of these cells at once, since, when 'the hand is in,' they will be made more dexterously than when the operation is performed only once; and it will be advantageous to subject them to the warmth of a slightly-heated oven, whereby the flattening of their surface will be more completely assured. The Microscopist will find it a matter of great convenience to have a stock of these cells always by him, ready prepared for use.

135. *Thin-Glass Cells*.—For the reception of objects too thick for varnish-cells, but not thicker than ordinary thin glass, it is advantageous to construct cells of glass; and these may be made in one of two ways, either by grinding-down the cross sections of glass-tubes (§ 137) until they have been reduced to the desired thinness, or by perforating a plate of thin glass with an aperture of the desired size; and then cementing the ring or the plate to the glass slide with marine glue. The former plan is liable to the objection, that in reducing the glass rings to the desired thinness, they are extremely liable to crack or break, and that their attainable forms are limited. The latter will generally answer very well, if care be taken in the selection of a *flat* piece of thin glass; and the perforation, if due precaution be employed, may be made of any size or form that may be desired. For making *round* cells, the perforated pieces that sometimes remain entire after the cutting of disks (§ 117) may be employed, the disks often falling-out of themselves when the glass is laid aside for a few days; and thus the same piece of thin glass may afford a plate, which, when cemented to a glass slide forms a cell, and a disk suitable as the cover to a cell of somewhat smaller size. There is great danger, however, of the cracking of the surrounding glass, especially when the disk is of large size; and it will generally be found a saving of trouble, to employ the method recommended by Dr. L. Beale. This consists in attaching a piece of thin glass to one of the glass rings of which the deeper cells are made (§ 137), of any form that may be desired, by means of marine-glue, first laid upon the latter, and melted upon the hot-plate; when the glue is quite cold, the point of a round or semicircular file is sharply

thrust through the centre of the thin glass, which is carefully filed to the size of the interior of the ring; and the ring being then heated a second time on the hot plate, the thin-glass-plate may be readily detached from it, and at once cemented upon the glass slide. The success of this simple process depends upon the very firm and intimate adhesion of the thin glass to the ring, which prevents any crack from running into the part of the thin-glass that is attached to it, however roughly the file may be used. By having many of the rings on the hot-plate at once, and operating with them in turn, a great number of cells can be made in a short time; and such large thin cells may be made in this mode, as could scarcely be fabricated (on account of the extreme brittleness of this glass) by any other. A *press*, consisting of two plates of brass screwed together, holding the thin glass between them, has been devised by Mr. C. Brooke for the same purpose; but the foregoing method has the advantage, not only of requiring no special apparatus, but also of enabling the form and size of the perforation to be readily varied.—After the thin-glass has been cemented to the slide, it is desirable to roughen its upper surface, by rubbing it upon a leaden or pewter plate (§ 108) with fine emery; since the gold-size or other varnish adheres much more firmly to a 'ground' than to a polished surface.—Although the thin-glass cell requires much more trouble in its preparation than the cement-cell, yet it is decidedly to be preferred for any very choice objects; since, if any air should find admission, it is more readily detected; and the remounting of the object may be accomplished in the same cell, with very little disturbance of its position.

136. *Plate-Glass and Shallow Cells*.—For mounting objects of somewhat greater thickness than can be included within thin-glass cells, *shallow* cells may be made by drilling apertures of the desired size in pieces of plate-glass of the requisite thickness, and by attaching these with marine glue to glass slides (Fig. 64). Such holes may be made not merely circular (A) but oval (C); and a very elongated perforation may be made, by drilling two holes at the required distance and then connecting them by cutting-out the intermediate space (B).—These operations, however, can scarcely be performed by any but regular glass-cutters, and, being troublesome, are expensive; hence the plate-glass cells have been generally superseded, either by *tube*-cells (§ 137) or by *built up* cells. Although the former may be reduced to any degree of shallowness that may be

desired, and are made of most of the sizes and forms that can be ordinarily needed, yet for extra-sizes or peculiar forms,

FIG. 64.

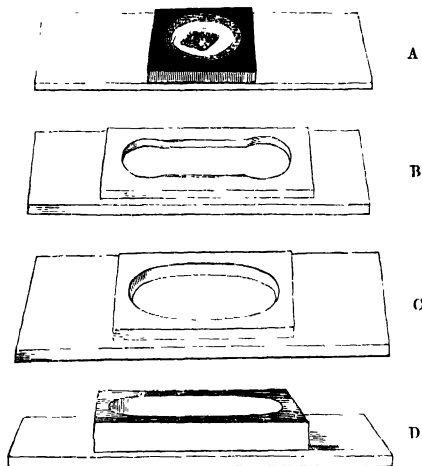

Plate-Glass Cells.

shallow cells may be easily built-up after the following very simple and effective method. A piece of plate-glass, of a thickness that shall give the desired depth to the cell, is to be cut to the dimensions of its outside wall; and a strip is then to be cut-off with the diamond from each of its edges, of such breadth as shall leave the interior piece equal in its dimensions to the cavity of the cell that is desired. This piece being rejected, the four strips are then to be cemented upon the glass slide in their original position, so that the diamond-cuts shall fit-together with the most exact precision; and the upper surface is then to be ground-flat with emery upon the pewter plate, and left rough as before. This plan answers admirably for constructing such large shallow cells as are required for the mounting of Zoophytes and similar objects.

137. *Deep and Built-up Cells.*—The *deep* cells which are required for mounting Injections and other microscopic pre-

parations of considerable size and thickness, *may* be made by drilling through a piece of thick plate-glass (Fig. 64, D); but for the reason already given, the drilled cells are now seldom used, their place having been taken, either by tube-cells, or by the deep built-up cells to be presently described.—The *tube-cells* are made by cutting transverse sections of thick-walled glass tubes of the required size, grinding the surfaces of these rings to the desired thinness, and then cementing them to the glass slides with marine glue. Not only may *round* cells (Fig. 65, A, B), of any diameter and any depth that the Microscopist can possibly require, be made by this simple

FIG. 65.

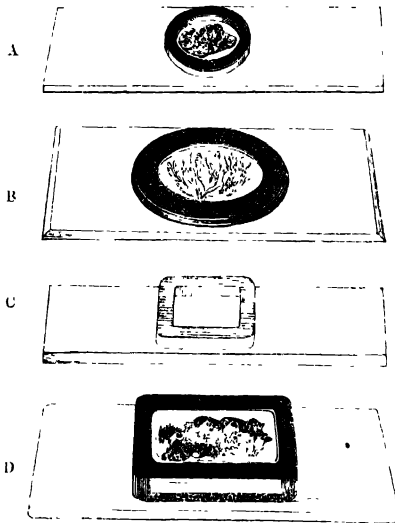

Tube-Cells, Round and Quadrangular.

method, but oval, square-shaped, or oblong cells (C, D) are now made, of the forms and sizes that he is most likely to want, by flattening the round glass-tube whilst hot, or by blowing it within a mould.—The facility with which such cells may be made, and the security they afford, have caused

the deep cells *built-up* of separate strips of glass (Fig. 66) to be comparatively little employed, except in cases where some

FIG. 66.

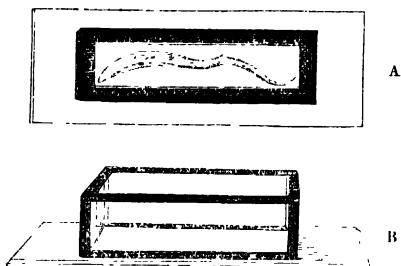

Built-up Cells.

very unusual size or shape (A) may be required, or where it is necessary that not merely the top and bottom, but also the sides of the object, should be clearly seen (B). The perfect construction of these requires a nicety of workmanship which few amateurs possess, and the expenditure of more time than Microscopists generally have to spare; and as it is consequently preferable to obtain them ready-made, directions for making them need not here be given. A new plan of making deep cells, however, has been lately introduced by Dr. L. Beale; which, though it does not give them side walls possessing the same flatness with those of the built-up cells, adapts them to serve most of the purposes for which these are required, and makes them more secure against leakage; whilst it has the advantage of being so easy and simple, that any one may put it into practice. A long strip of plate-glass is to be taken, whose breadth is equal to the desired depth of the cell, and whose length must be equal to the sum of that of all its sides. This strip is to be carefully bent to a right angle in the blow-pipe flame, at three points previously indicated by marks so placed as to show where the angles should fall; and the two ends, which will thus be brought into contact at right angles, are to be fused together. Thus a large square well, slightly rounded at the angles, will be formed; and this, being very brittle, should be allowed to cool very gradually, or, still better, should be annealed in an oven. It must then be

ground quite true on its upper and lower edges, either on the lead-plate with emery, or on a flat stone with fine sand; and it may then be cemented to a glass slide in the usual way.

138. *Mounting Objects in Cells.*—In mounting an object in a cell, the first attention will of course be given to the cleanness of the interior of the cell, and of the glass cover which is to be placed on it; this having been secured, the cell is to be filled with fluid by the pipette or syringe; and any minute air-bubbles which may be seen adhering to its bottom or sides, must be removed by the needle: the object, previously soaked in fluid resembling that with which the cell is filled, is then to be placed in the cell, and should be carefully examined for air-bubbles on all sides, and also by looking-up from below. When every precaution has been taken to free it from these troublesome intruders, the cover may be placed on the cell, one side being first brought-down upon its edge and then the other; and if the cell have been previously brimming-over with fluid (as it ought to be), it is not likely that any air-space will remain. If, however, any bubbles should present themselves beneath the cover, the slide should be inclined, so as to cause them to rise towards the highest part of its circumference, and the cover slipped-away from that part, so as to admit of the introduction of a little additional fluid by the pipette or syringe; and when this has taken the place of the air-bubbles, the cover may be slipped-back into its place.* All superfluous fluid is then to be taken-up with blotting-paper; and particular care should be taken thoroughly to dry the surface of the cell and the edge of the cover, since the varnish will not hold to them if they be in the least damp with water. Care must also be taken, however, that the fluid be not drawn-away from between the cover and the edge of the cell on which it rests; since any deficiency here is sure to be filled-up by varnish, the running-in of which is particularly objectionable. These minutiae having been attended-to, the closure of the cell may be at once effected, by carrying a thin layer of gold-size or asphalté around and upon the edge of the glass-

* Mr. Quekett and some other practised manipulators recommend that the edges of the cell and that of the disk of glass be smeared with the gold-size or other varnish employed, before the cell is filled with fluid; but the Author has found this practice objectionable, for two reasons,—first, because it prevents the cover from being slipped to one side (which is often desirable), without its being soiled by the varnish,—and second, because when the edge of the cell has been thus made to 'take' the varnish, that which is afterwards applied for the closure of the cell is more likely to run-in, than if the whole of the surface covered by the glass is moistened with water.

cover, taking care that it touches every point of it, and fills the angular channel which is left around its margin.—If the wall of the cell be very thin, it will be advantageous to include it in the ring of varnish; so that this shall hold-down the cover, not only on the cell, but on the slide beneath.—The Author has found it advantageous, however, to delay closing the cell for some little time after the superfluous fluid has been drawn-off; for as soon as evaporation beneath the edges of the cover begins to diminish the quantity of fluid in the cell, air-bubbles often begin to make their appearance, which were previously hidden in the recesses of the object; and in the course of half an hour, a considerable number are often collected. The cover should then be slipped-aside, fresh fluid be introduced, the air-bubbles removed, and the cover put-on again; and this operation should be repeated, until it fails to draw-forth any more air-bubbles. It will, of course, be observed, that, if the evaporation of fluid should proceed far, air-bubbles will *enter* beneath the cover; but these will show themselves on the *surface* of the fluid; whereas those which arise from the object itself, are found in the deeper parts of the cell. Much time may be saved, however, and the freedom of the preparation from air-bubbles may be most effectually secured, by placing the cell, after it has been filled in the first instance, in the vacuum of an air-pump; and if several objects are being mounted at once, they may all be subjected to the exhausting process at the same time.—The application of the varnish should be repeated after the lapse of a few hours, and may be again renewed with advantage several times in the course of a week or two; care being taken that each layer covers the edges, as well as the whole surface, of that which preceded it.

139. The presence of air-bubbles, in any preparation mounted in fluid, is to be particularly avoided, not merely on account of its interference with the view of the object, but also because, when air-spaces, however small, once exist, they are almost certain to increase, until at last they take the place of the entire fluid, and the object remains dry. Even with the most experienced manipulators, however, this misfortune not unfrequently occurs; being sometimes due to the obstinate entanglement of air-bubbles in the object, when it was originally mounted; and sometimes to the perviousness of some part of the cement, which has allowed a portion of the contained fluid to escape, and air to find admission. In either case, so soon as an air-bubble is seen in such a preparation,

the attempt should be made to prevent its increase, by laying-on an additional coat of varnish; but if this should not be successful, the cover should be taken-off, and the specimen remounted, so soon as the fluid has escaped to such a degree as to leave any considerable portion of it uncovered.

140. *Importance of Cleanliness.*—The success of the result of any of the foregoing operations is greatly detracted from, if, in consequence of the adhesion of foreign substances to the glasses whereon the objects are mounted, or to the implements used in the manipulations, any extraneous particles are brought into view with the object itself. Some such will occasionally present themselves, even under careful management; especially fibres of silk, wool, cotton, or linen, from the handkerchiefs, &c., with which the glass slides may have been wiped, and grains of starch, which often remain obstinately adherent to the thin-glass covers kept in it. But a careless and uncleanly manipulator will allow his objects to contract many other impurities than these; and especially to be contaminated by particles of dust floating through the air, the access of which may be readily prevented by proper precautions. It is desirable to have at hand a well-closed cupboard furnished with shelves, or a cabinet of well-fitted drawers, or a number of bell-glasses upon a flat table, for the purpose of securing our glasses, objects, &c., from this contamination, in the intervals of the work of preparation; and the more readily accessible these receptacles are, the more use will the Microscopist be likely to make of them. Great care ought, of course, to be taken, that the liquids employed for mounting should be freed, by effectual filtration, from all floating particles; and both these and the Canada balsam should be kept in well-closed bottles.

141. *Labelling and Preserving of Objects.*—Whenever the mounting of an object has been completed, its name ought to be at once marked on it, and the slide should be put-away in its appropriate place. Some inscribe the name on the glass itself, with a writing diamond; whilst others prefer to gum a label* on the slide; and others, again, cover one or both surfaces of the slide with coloured paper, and attach the label to it. In the case of objects mounted dry or in balsam, the latter method has the advantage of rendering the glass cover more secure from displacement by a slight blow or 'jar.'

* Very neat gummed labels, of various sizes and patterns suitable to the wants of the Microscopist, are sold by the 'Diapers' Stationers' in the City.

when the varnish or balsam may have become brittle by the lapse of years. Instead, however, of attaching the white label on which the name of the object is written, outside the coloured paper with which the slide is covered, it is better to attach the label to the glass, and to punch a hole out of the coloured paper, sufficiently large to show the name, in the part corresponding to it; in this manner the label is prevented from falling-off, which it frequently does when attached to the glass without protection, or to the outside of the paper-cover. When objects are mounted in fluid, either with or without cells, paper coverings to the slides had better be dispensed-with; and besides the name of the object, it is desirable to inscribe on the glass that of the fluid in which it is mounted. —For the preservation of objects, the pasteboard boxes now made at a very reasonable cost, with wooden racks, to contain 6, 12, or 24 slides, will be found extremely useful. In these, however, the slides must always stand upon their edges; a position which, besides interfering with that ready view of them which is required for the immediate selection of any particular specimen, is unfavourable to the continued soundness of preparations mounted in fluid. Although such boxes are most useful, indeed almost indispensable, to the Microscopist, for holding slides which he desires (for whatever purpose) to keep for a while constantly at hand, yet his regularly-classified series is much more conveniently stored in a Cabinet containing numerous very shallow drawers, in which they lie flat and exposed to view. Such cabinets are now prepared for sale under the direction of our principal Opticians, with all the improvements that experience has suggested. In order to prevent the warping of the thin wood of which the bottoms of the drawers are usually made, whereby their sliding action is obstructed, it has been found advantageous to substitute strained canvas or papier mâché. Again, in order to antagonize the disposition of the slides to slip one over another in the opening or shutting of the drawers, it has been found preferable to arrange them in such a manner, that they lie with their ends (instead of their long sides) towards the front of the drawer, and to interpose a cross-strip of wood, lying parallel to the front of the drawer, between each row. It is very convenient, moreover, for the front of the drawer to be furnished with a little tablet of porcelain, on which the name of the group of objects it may contain can be written in pencil, so as to be readily rubbed-out; or a small frame may

be attached to it, into which a slip of card may be inserted for the same purpose.

Section 3.—*Collection of Objects.*

142. A large proportion of the objects with which the Microscopist is concerned, are derived from the minute parts of those larger organisms, whether Vegetable or Animal, the collection of which does not require any other methods than those pursued by the ordinary Naturalist. With regard to such, therefore, no special directions are required. But there are several most interesting and important groups, both of Plants and Animals, which are themselves, on account of their minuteness, essentially microscopic; and the collection of these requires peculiar methods and implements, which are, however, very simple,—the chief element of success lying in the knowledge *where* to look, and *what* to look-for. In the present place, *general* directions only will be given; the particular details relating to the several groups, being reserved for the account to be hereafter given of each.

143. All the Microscopic organisms in question, being aquatic, must be sought-for in pools, ditches, streams, or other collections of water; through which some of them freely move, whilst others attach themselves to the stems and leaves of aquatic plants, or even to pieces of stick or decaying leaves, &c. that may be floating on the surface or submerged beneath it, while others, again, are to be sought-for in the muddy sediments at the bottom. Of those which have the power of free motion, some keep near the surface, whilst others swim in the deeper waters; but the situation of many depends entirely upon the light, since they rise to the surface in sunshine, and subside again afterwards. The Collector will therefore require a means of obtaining samples of water at different depths, and of drawing to himself portions of the larger bodies to which the microscopic organisms may be attached. For these purposes, nothing is so convenient as a rod about five feet long, which may be divided into two pieces jointed-together; and the farther extremity of this rod should be pierced with a hole, passing for some distance into its length.* Into this hole, as a socket, may be fitted either of the three

* Cheap fishing-rods are now sold at the toy-shops, which answer this purpose extremely well, the last or slenderest joint being laid on one side; its socket in the last joint but one, being well adapted to receive the fittings above described.

implements which the Collector may happen to require.—If he desires to take-up samples of the water, he will need a wide-mouthed bottle, containing about 2 oz. This may be attached to the extremity of the rod, by simply passing round its neck a strap of thin whalebone or sheet gutta-percha, the two ends of which are to be brought-together, and inserted into the socket, in which they may be secured by a plug of soft wood or cork. The bottle being held sideways with its mouth partly below the water, the surface may be skimmed; or, if it be desired to bring-up a sample of the liquid from below, or to draw into the bottle any bodies that may be loosely attached to the submerged plants, the bottle is to be plunged into the water with its mouth downwards, carried into the situation in which it is desired that it should be filled, and then suddenly turned with its mouth upwards.—If, again, the organisms which it may be desired to collect, are of sufficient size to be strained-out of the water by a piece of fine muslin, a ring-net should be fitted into the socket of the rod. This may be made by sewing the muslin bag to a ring of stout wire, furnished with a projecting stem which may be inserted by means of a cork into the socket of the rod. But it is more convenient that the muslin should be made removable; and this may be provided-for (as suggested in the “Micrographic Dictionary,” Introduction, p. xxiv.) by the substitution of a wooden-ring, grooved on its outside, for the wire-ring; the muslin being strained upon it by a ring of vulcanized India rubber, which lies in the groove, and which may be readily slipped off-and-on, so as to allow a fresh piece of muslin to be put in the place of that which has been last used.—For bringing-up portions of larger Plants, either for the sake of examining their own structure, or for obtaining the growths which may be parasitic upon them, a cutting-hook, shaped somewhat like a sickle, may be fitted into the socket of the rod.

144. The Collector should also be furnished with a number of bottles, into which he may transfer the samples thus obtained. These it will be convenient to have of two kinds; one set wide-mouthed, and capable of being closely corked, for minute Plants; the other set with narrower mouths, having short pieces of tube passed through the corks, for the purpose of containing Animalcules without depriving them of air. The former kind, however, may be safely employed for Animalcules, if they be not above two-thirds filled (so as to leave an adequate air-space), and be not kept long closed.

Such bottles should be fitted into cases, in which several may be carried at once without risk of breakage.*—Whilst engaged in the search for Microscopic objects, it is desirable for the collector to possess a means of at once recognizing the forms which he may gather, where this is possible, in order that he may decide whether the 'gathering' is, or is not, worth preserving; for this purpose either a powerful 'Coddington' or 'Stanhope' lens (§ 19), or a Gairdner's Simple Microscope (§ 28), will be found most useful, according to the class of objects of which the collector is in search. The first will answer very well for Zoophytes and the larger Diatomaceæ; but the second or third will be needed for Desmidiaceæ, the smaller Diatomaceæ, and Animalcules.

* The bottles in which smelling-salts are now commonly sold, having the corks fitted into disks of turned wood, are very convenient, both in size and shape, for the purposes of the Microscopist; cases containing 3, 4, 6, or 8 such bottles, are made by Mr. Ferguson of Giltspur-street. The wide-mouthed bottles with screw caps, made by the York Glass Company, are also extremely convenient.

CHAPTER VI.

MICROSCOPIC FORMS OF VEGETABLE LIFE.—PROTOPHYTES.

145. IN commencing our survey of these wonders and beauties of Life and Organization, which are revealed to us by the assistance of the Microscope, it seems on every account the most appropriate to turn our attention in the first instance to the Vegetable Kingdom; and to begin with those humblest members of that kingdom, whose form and structure, and whose very existence, in many cases, are only known to us through its use. For those who desire to make themselves familiar with microscopic appearances, and to acquire dexterity in microscopic manipulation, cannot do better than educate themselves by the study of those comparatively simple forms of organization, which the Vegetable fabric presents; since a facility in minute dissection and in microscopic analysis may be thus acquired, which will save much expenditure of time and labour, that might be unprofitably applied, without such apprenticeship, to the attempt to unravel the complexities of Animal organization. But further, the scientific Histologist (p. 20) looks to the careful study of the structure of the simplest forms of Vegetation, as furnishing the key (so to speak) that opens the right entrance to the study of the elementary Organization, not merely of the higher Plants, but of the highest Animals. And in like manner, the scientific Physiologist looks to the complete knowledge of their life-history, as furnishing the surest basis for those general notions of the nature of Vital Action, which the advance of science has shown to be really well-founded, only when they prove equally applicable to both kingdoms.—But further, a peculiar interest attaches itself at the present time, to everything which throws light upon the debated question of the boundary between the two kingdoms; a question which is not less keenly debated among Naturalists, than that of many a disputed frontier has been between adjacent Nations. For many parts of this border-country have been taken and retaken several times; their inhabitants (so to speak) having first been considered, on account of their general appearance, to belong to

the Vegetable Kingdom,—then, in consequence of some movements being observed in them, being claimed by the Zoologists,—then, on the ground of their evidently-plant-like mode of growth, being transferred-back to the Botanical side,—then, owing to the supposed detection of some new feature in their structure or physiology, being again claimed as members of the Animal Kingdom,—and lastly, on the discovery of a fallacy in these arguments, being once more laid-hold-of by the Botanist, with whom, for the most part, they now remain. For the attention which has been given of late years to the study of the humblest forms of Vegetation, has led to the knowledge of so many phenomena, among what must be *undoubtedly* regarded as Plants, which would formerly have been considered unquestionable marks of animality, that the discovery of the like phenomena among the doubtful beings in question, so far from being any evidence of *their* animality, really affords a probability of the opposite kind.

146. In the present state of Science, it would be very difficult, and is perhaps impossible, to lay down any definite line of demarcation between the two kingdoms; since there is no single character by which the Animal or Vegetable nature of any organism can be tested. Probably the one which is most generally applicable, among those lowest organisms which most closely approximate to one another, is—not, as formerly supposed, the presence or absence of spontaneous motion, but the dependence of the being for nutriment upon *organic compounds* already formed, which it takes (in some way or other) into the *interior* of its body, or its possession of the power of obtaining its own alimentary matter by absorption, from the *inorganic elements* on its *exterior*. The former is the characteristic of the *Animal Kingdom* as a whole; the latter is the attribute of the *Vegetable*; and although certain apparently-exceptional cases *may* exist, yet these do not seem to occur among the group in which such a means of distinction is most useful to us. For we shall find that those *Protozoa*, or simplest Animals, which seem to be composed of nothing else than a mass of living jelly (Chaps. ix., x.), are supported as exclusively, either upon other *Protozoa*, or upon *Protophyta* which are humble Plants of equal simplicity, as the highest Animals are upon the flesh of other Animals, or upon the products of the Vegetable Kingdom; whilst these *Protophytes*, in common with the highest Plants, draw *their* nourishment from water, carbonic acid, and ammonia, and are distinguished by their power of liberating oxygen, through the decomposi-

tion of carbonic acid, under the influence of sun-light. And we shall moreover find, that even such *Protozoa* as have neither stomach nor mouth, receive their alimentary matter direct into the very substance of their bodies, in which it undergoes a kind of digestion; whilst the *Protophyta* absorb through their external surface only, and take-in no solid particles of any description. With regard to motion, which was formerly considered the distinctive attribute of animality, we now know, not merely that many Protophytes (perhaps all, at some period or other of their lives) possess a power of spontaneous movement, but also that the instruments of motion, when these can be discovered, are of the very same character in the Plant as in the Animal; being little hair-like filaments termed *cilia* (from the Latin *cilium*, an eye-lash), by whose rhythmical vibration the body of which they form part is propelled in definite directions. The peculiar contractility of these cilia cannot be accounted-for in either case, any better than in the other; all we can say is, that it seems to depend upon the continued vital activity of the living substance of which these filaments are prolongations; and that this contractile substance has a composition essentially the same in the Plant as in the Animal.

117. The plan of organization throughout the Vegetable kingdom presents this remarkable feature of uniformity,—that the fabric of the highest and most complicated Plants, consists of nothing else than an aggregation of the bodies termed *cells*, every one of which, among the lowest and simplest forms of Vegetation, may maintain an independent existence, and may multiply itself almost indefinitely, so as to form vast assemblages of similar bodies. And the essential difference between the plans of structure in the two cases lies in this,—that the cells produced by the self-multiplication of the primordial cell of the Protophyte, are all mere repetitions of it and of one another, each living *by* and *for* itself,—whilst those produced by the like self-multiplication of the primordial cell in the Oak or Palm, not only remain in mutual connection, but undergo a progressive ‘differentiation,’ a fabric being thereby developed, which is composed of a number of distinct organs (stem, leaves, roots, flowers, &c.), each of them characterized by specialities not merely of external form but of intimate structure (the ordinary type of the cell undergoing various modifications, to be described in their proper place, Chap. viii.), and performing actions peculiar to itself, which contribute to the life of the Plant *as a whole*. Hence, as was

first definitely stated by Schleiden (see Introduction, p. 12), it is in the *life-history of the individual cell*, that we find the true basis of the study of Vegetable Life in general. And we shall now enquire, therefore, what information on this point we derive from Microscopic research.—In its most completely-developed form, the Vegetable Cell may be considered as a closed membranous bag or vesicle, containing a fluid cell-sap; and thus we have to consider separately the *cell-wall* and the *cell-contents*. The 'cell-wall' is composed of two layers, of very different composition and properties. The *inner* of these, which has received the name of *primordial utricle*, appears to be the one first formed, and most essential to the existence of the cell; it is extremely thin and delicate, so that it escapes attention so long as it remains in contact with the external layer; and it is only brought into view when separated from this, either by developmental changes (Fig. 107), or by the influence of re-agents which cause it to contract by drawing-forth part of its contents (Fig. 175). Its composition is indicated, by the effects of re-agents, to be *albuminous*; that is, it agrees with the formative substance of the Animal tissues, not only in the proportions of oxygen, hydrogen, carbon, and nitrogen which it contains, but also in the nature of the compound formed by the union of these elements. The external layer, on the other hand, though commonly regarded as the proper 'cell-wall,' is generated on the surface of the primordial utricle, after the latter has completely enclosed the cavity and its contents, so that it takes no essential part in the formation of the cell. It is usually thick and strong in comparison with the other, and may often be shown to consist of several layers. In its chemical nature it is altogether dissimilar to the primordial utricle; for it is essentially composed of *cellulose*, a substance containing no nitrogen, and nearly identical with starch. The relative offices of these two membranes are very different; for whilst there are many indications that the primordial utricle continues to participate actively in the vital operations of the cell, it seems certain that the cellulose-wall takes no concern in them, but is only their product; its function being simply protective.—The contents of the vegetable-cell, being usually more or less deeply coloured, have received the collective designation of *endochrome* (or internal colouring-substance); and they essentially consist of a layer of colourless 'protoplasm' (or organizable fluid, containing albuminous matter in combination with dextrine or starch-gum) in immediate contact with the primordial utricle,

within which is the more watery cell-sap, particles of chlorophyll or colouring-substance being diffused through both, or through the former only.

148. But although these component parts may be made-out without any difficulty in a large proportion of Vegetable cells, yet they cannot be distinguished in some of those humble organisms, which are nearest to the border-ground between the two kingdoms. For in them we find the 'cell-wall' very imperfectly differentiated from the 'cell-contents;' the former not having by any means the firmness of a perfect membrane, and the latter not possessing the liquidity which elsewhere characterizes them. And in some instances, the cell appears to be represented only by a mass of endochrome, so viscid as to retain its external form without any limitary membrane, though the superficial layer seems to have a firmer consistence than the interior substance; and this may or may not be surrounded by a gelatinous-looking envelope, which is equally far from possessing a membranous firmness, and yet is the only representative of the cellulose-wall. This viscid endochrome consists, as elsewhere, of a colourless protoplasm, through which colouring particles are diffused, sometimes uniformly, sometimes in local aggregations, leaving parts of the protoplasm uncoloured. The superficial layer, in particular, is frequently destitute of colour; and the 'primordial utricle' appears to be formed by its solidification. In the interior of the viscid mass, are commonly found *vacuoles*, which are distinguished from the surrounding substance by their difference in refracting power; these, however, are not usually void spaces, but are cavities in the protoplasm occupied by fluid of a more watery consistence; and this 'vacuolation' of the interior, which increases until the cell-contents have almost entirely lost their original viscosity and are of a more watery character, seems to take place *pari passu* with the consolidation of the exterior into distinct membranous walls; so that the development of a perfect cell out of a rudimentary mass of endochrome, may be stated to consist essentially in the *gradual differentiation* of its substance, which was at first a nearly homogeneous viscid mass, into the solid cell-wall and the liquid cell-contents.—It is interesting to observe, at the very outset of our enquiry into the nature of Organisation and Vital action, so characteristic an illustration of the great law of Von Bar already referred-to (pp. 23, 27).

149. Now among the *Protophytes* or simplest Plants, on the examination of which we are about to enter, there are many, of

which every single cell is not only capable of living in a state of isolation from the rest, but even normally does so; and thus, in the ordinary phraseology, every cell is to be accounted a 'distinct individual.' There are others, again, of which shapeless masses are made-up by the aggregation of contiguous cells, which, though quite capable of living independently, remain attached to each other by the mutual fusion (so to speak) of their gelatinous investments. And there are others, moreover, in which a definite adhesion exists between the cells, and in which regular plant-like structures are thus formed, notwithstanding that every cell is still but a repetition of every other, and is capable of living independently if detached, so as to answer to the designation of a 'unicellular' or single-celled plant. These different conditions we shall find to arise out of the mode in which each particular species multiplies by binary subdivision (§ 150): for where the pair of cells that is produced by the segmentation of the previous cell, undergo a *complete* separation from one another, they will henceforth live quite separately; but if, instead of undergoing this complete fusion, they should be held-together by the intervening gelatinous envelope, a shapeless mass results from repeated subdivisions not taking place on any determinate plan; and if, moreover, the binary subdivision should always take-place in a determinate direction, a long narrow filament (Fig. 10 t, d), or a broad flat leaf-like expansion (Fig. 10 t, c), may be generated. To such extended fabrics, the term 'unicellular plants' can scarcely be applied with propriety, since they may be built-up of many thousands or millions of distinct cells, which have no disposition to separate from each other spontaneously. Still they correspond with those which are strictly unicellular, in the absence of any differentiation, either in structure or in actions, between their component cells; each one of these being a repetition of the rest, and no relation of mutual dependence existing among them.—All such organisms may well be included under the general term of *Protophytes*, by which it is convenient to designate the primitive or elementary forms of Vegetation; and we shall now enter, in such detail as the nature of the present Treatise allows, into the history of those forms of the group, which present most of interest to the Microscopist, or which best serve to illustrate the general doctrines of Physiology.

150. The life-history of one of these Unicellular Plants, in its most simple form, can scarcely be better exemplified than in the *Palmoglea macrococca* (Kützing); one of those

humble kinds of vegetation which spreads itself as a green slime over damp stones, walls, &c. When this slime is examined with the microscope, it is found to consist of a multitude of green cells (Fig. 67, A), each surrounded by

FIG. 67.

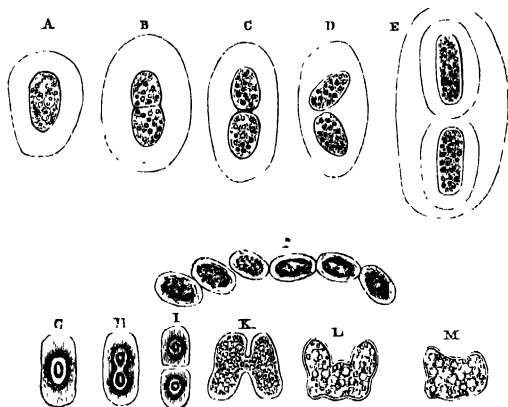

Various phases of development of *Palaeoglaea macrococca*; A, full-grown cell, B, C, D, E, successive stages of binary subdivision; F, row of cells, produced by succession of subdivisions, G, H, I, cells treated by iodine, K, L, M, cells in conjugation.

a gelatinous envelope; the cell, which does not seem to have any distinct membranous wall, is filled with granular particles of a green colour; and a 'nucleus' may sometimes be distinguished through the midst of these. When treated with tincture of iodine, however, the green contents of the cell are turned to a brownish hue, and a dark-brown nucleus is distinctly shown (G). Other cells are seen (H), which are considerably elongated, some of them beginning to present a sort of hour-glass contraction across the middle; in these is commencing that curious *multiplication by duplicative subdivision*, which is the mode in which increase nearly always takes-place throughout the Vegetable kingdom; and when cells in this condition are treated with tincture of iodine, the nucleus is seen to be undergoing the like elongation and constriction (H). A more advanced state of the process of subdivision is seen at C, in which the constriction has proceeded to the

extent of completely cutting-off the two halves of the cell, as well as of the nucleus (i), from each other, though they still remain in mutual contact; but in a yet later stage, they are found detached from each other (n), though still included within the same gelatinous envelope. Each new cell then begins to secrete its own gelatinous envelope; so that, by its intervention, the two are usually soon separated from one another (*). Sometimes, however, this is not the case; the process of subdivision being quickly repeated, before there is time for the production of the gelatinous envelope, so that a series of cells (f), hanging-on one to another, is produced. There appears to be no definite limit to this kind of multiplication; and extensive areas may be quickly covered, in circumstances favourable to the growth of the plant, by the products of the duplicative subdivision of one primordial cell. This, however, is simply an act of *Growth*, precisely analogous to that by which any one of the higher forms of Vegetation extends itself, and differing only in this, that the cells produced by each act of cell-subdivision in the present case exactly resemble that from which they sprang; whilst in the case of more highly organized Plants, they gradually become differentiated to a greater or less degree, so that special 'organs' are evolved, which take upon themselves dissimilar yet mutually-dependent parts, in the economy of the entire organism.

151. The process which represents the *Generation* of the higher Plants, is here performed in a manner so simple, that it would not be recognized as such, if we were not able to trace it up through a succession of modes of gradually-increasing complexity, until we arrive at the elaborate operations which are concerned in the production and fertilization of the seeds of Flowering Plants. For it consists in nothing else than the reunion or fusion together of any pair of cells (κ),—a process which is termed *Conjugation*; and it is characteristic of this humble plant, and shows how imperfect must be the consistence of its cell-membrane, that this seems to enter into the fusion, no less completely than the cell-contents. The communication is at first usually made by a narrow neck or bridge (κ); but before long it extends through a large part of the contiguous boundaries (l); and at last the two cells are seen to be completely fused into one mass (m); which is termed the *spore*. Each 'spore' thus formed is the 'primordial cell' of a *new generation*, into which it evolves itself by successive repetitions of the process of binary subdivision.—It is curious to observe, that during the conjugating

process, a production of oil-particles takes-place in the cells; these at first are small and distant, but gradually become larger and approximate more closely to each other, and at last coalesce so as to form oil-drops of various sizes, the green granular matter disappearing; and the colour of the conjugated body changes, with the advance of this process, from green to a light yellowish-brown. When the spore begins to vegetate, on the other hand, producing a pair of new cells by binary subdivision, a converse change takes-place; the oil-globules disappear, and green granular matter takes their place. Now this is precisely what occurs in the formation of seed among the higher Plants; for starchy substances are transformed into oil, which is stored-up in the seed for the nutrition of the embryo, and is applied, during germination, to the purposes which are at other times answered by starch or chlorophyll.—The *growth* of this little plant appears to be favoured by cold and damp; its *generation*, on the other hand, is promoted by heat and dryness; and it is obvious that the spore-cell must be endowed with a greater power of resisting this, than the vegetating plant has, since the species would otherwise be destroyed by every drought.

152. If the preceding sketch really comprehends the whole life-history of the humble plant to which it relates, this history is much more simple than that of other forms of vegetation, which, without appearing to possess an essentially-higher structure, present themselves under a much greater variety of forms and conditions. One of the most remarkable of these varieties is the *motile* condition, which seems to be common, in some stage or other of their existence, to a very large proportion of the lower forms of aquatic vegetation; and which usually depends upon the extension of the primordial utricle into one or two thread-like filaments (Fig. 68, II—I), endowed with the power of executing rhythmical contractions, whereby the cell is impelled through the water.—As an illustration of this peculiar mode of activity, which was formerly supposed to betoken Animal life, a sketch will be given of the history of a plant, the *Protococcus plurialis*, which is not uncommon in collections of rain-water,*

* The Author had under his own observation, about eight years ago, an extraordinary abundance of what he now feels satisfied must have been this plant, in a rain-water cistern, which had been newly cleaned-out. His notice was attracted to it, by seeing the surface of the water covered with a green froth, whenever the sun shone upon it. On examining a portion of this froth under the Microscope, he found that the water was crowded with green cells in active motion; and although the only bodies at all resembling them, of

and which, in its motile condition, has been very commonly regarded as an Animalcule, its different states having been described under several different names.

153. In the first place, the colour of these cells varies considerably; since, although they are usually green at the period of their most active life, they are sometimes red; and their red form has received the distinguishing appellation of *Hæmatococcus*. Very commonly the red colouring-matter forms only a central mass of greater or less size, having the appearance of a nucleus (as shown in Fig. 68, ϵ); and sometimes it is reduced to a single granular point, which has been erroneously represented by Prof. Ehrenberg as the eye of these so-called Animalcules. It is quite certain that the red colouring-substance is very nearly related in its chemical character to the green, and that the one may be converted into the other; though the conditions under which this conversion may take place are not precisely known. In the *still* form of the cell, with which we may commence the history of its life, we find a mass of endochrome, consisting of a colourless protoplasm, through which red or green-coloured granules are more or less uniformly diffused; on the surface of this endochrome, the colourless protoplasm is condensed

which he could find any description, were the so-called *Animalcules*, constituting the genus *Chlamydomonas* of Prof. Ehrenberg, and very little was known at that time of the 'motile' conditions of *Plants* of this description, yet of the vegetable nature of these bodies he could not entertain the smallest doubt. They appeared in freshly collected rain-water, and could not, therefore, be deriving their support from organic matter, under the influence of light, they were obviously decomposing carbonic acid and liberating oxygen, and this influence he found to be essential to the continuance of their growth and development, which took place entirely upon the Vegetative plan. Not many days after the Protophyte first appeared in the water, a few Wheel-Animalcules presented themselves, these fed greedily upon it, and increased so rapidly (the weather being very warm) that they soon became almost as crowded as the cells of the *Protococcus* had been; and it was probably due in part to their voracity, that the plant soon became less abundant, and before long disappeared altogether. Had the Author been then aware of its assumption of the 'still' condition, he might have found it at the bottom of the cistern, after it had ceased to present itself at the surface.—The account of this Plant given above, is derived from that of Dr. Cohn, in the "*Nova Acta Acad. Nat. Curios.*," (Bonn, 1850), tom. xxii.; of which an abstract by Mr. George Busk is contained in the "*Botanical and Physiological Memoirs*," published by the Ray Society for 1853. This excellent observer states that he kept his plants for observation in little glass vessels, having the form of a truncated cone, about two inches deep, and one inch and a quarter in diameter, with a flat bottom polished on both sides, and filled with water to the depth of from two to three lines. "It was only in vessels of this kind," he says, "that he was able to follow the development of a number of various cells throughout its whole course." Probably he would have found the glass-tube cells represented in Fig. 65, if he had been acquainted with them, to answer his purpose just as well as these specially constructed vessels.

into a more consistent layer, forming an imperfect 'primordial utricle;' and this is surrounded by a tolerably firm layer, which seems to consist of cellulose or of some modification of it. Outside this (as shown in Fig. 68, A), when the 'still'

FIG. 68.

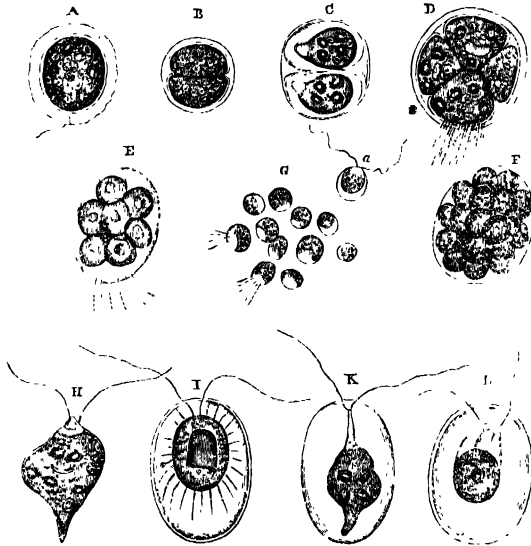

Various phases of development of *Protococcus pluvialis* - - A, an encysted cell, which has passed into the 'still' condition; B, division of a 'still' cell into two; C, another mode of division into two, each primordial vesicle having developed a cellulose envelope; and itself, whilst yet within the original cell; D, division of an encysted cell into four; E, division of an encysted cell into thirty-two segments; G, motile gonidia (zoospores) after their escape from the original cell; H, a primordial utricle, with cellulose envelope, furnished with a distinct utricle, with distinct cellulose envelope, and threads of protoplasm extending towards it; K, an encysted cell, with cellulose envelope, and furnished with two utricles, of which nearly half is composed of a colourless granular substance, enclosing a red body resembling a nucleus.

cell is formed by a change in the condition of a cell that has been previously 'motile,' we find another envelope, which seems

to be of the same nature, but which is separated by the interposition of aqueous fluid; this, however, may be altogether wanting. The multiplication of the 'still' cells by self-division, takes place as in the previous instance; the endochrome, enclosed in its primordial utricle, first undergoing separation into two halves (as seen at B), and each of these halves subsequently developing a cellulose envelope around itself, and undergoing the same division in its turn. Thus 2, 4, 8, 16 new cells are successively produced; and these are sometimes set-free by the complete dissolution of the envelope of the original cell; but they are more commonly held-together by its transformation into a gelatinous investment, in which they remain imbedded. Sometimes the contents of the primordial utricle subdivide at once into *four* segments (as at D), of which every one forthwith acquires the characters of an independent cell; but this, although an ordinary method of multiplication among the 'motile' cells, is comparatively rare in the 'still' condition. Sometimes, again, the cell-contents of the 'still' form subdivide at once into eight portions, which, being of small size, and endowed with motile power, may be considered as 'zoospores;' it is not quite clear what becomes of these; but there is reason to believe that some of them retain their motile powers, and, after increasing in size, develop an investing cyst, like the free primordial utricles to be presently described; that others produce a firm cellulose envelope, and become 'still' cells; and that others (perhaps the majority) perish without any further change.

154. When the ordinary self-division of the 'still' cells into two segments has been repeated four times, so as to produce 16 cells—and sometimes at an earlier period,—the new cells thus produced assume the 'motile' condition; being liberated before the development of the cellulose envelope, and becoming furnished with two long vibratile filaments, which appear to be extensions of the primordial utricle (H). In this condition, it seems obvious that the colourless protoplasm is more developed relatively to the colouring-matter, than it is in the 'still' cells; it generally accumulates in the part from which the vibratile filaments or cilia proceed, so as to form a sort of transparent beak (H, K, L); and it usually contains 'vacuoles,' occupied only by clear aqueous fluid, which are sometimes so numerous as to take-in a large part of the cavity of the cell, so that the coloured contents seem only like a deposit on its walls. Before long, this 'motile'

primordial utricle acquires a peculiar saccular investment, which seems to correspond with the cellulose envelope of the 'still' cells, but which is not so firm in its consistence (I, K, L). Thread-like extensions of the protoplasm, sometimes containing coloured globules, are not unfrequently seen to radiate from the primordial utricle towards the exterior of this enveloping bag (I); these are rendered more distinct by iodine, and can be made to retract by means of reagents; and their existence seems to show, on the one hand, that the transparent space through which they extend themselves is only occupied by a watery liquid, and on the other, that the layer of protoplasm which constitutes the primordial utricle, is far from possessing the tenacity of a completely-formed membrane.—The vibratile filaments pass through the cellulose envelope, which invests them with a sort of sheath; and in the portion that is within this sheath, no movement is seen. During the active life of the 'motile' cells, the vibration of these cilia is so rapid, that it can be recognised only by the currents it produces in the water, through which the cells are rapidly propelled; but when the motion becomes slacker, the filaments themselves are readily distinguishable; and they may be made more obvious by the addition of iodine.—The multiplication of these motile cells may take-place in various modes, giving rise to a great variety of appearances. Sometimes they undergo a regular binary subdivision, whereby a pair of motile cells is produced (C), each resembling its single predecessor in possessing the cellulose investment, the transparent beak, and the vibratile filaments, before the solution of the original investment. Sometimes, again, the contents of the primordial cell undergo a segmentation in the first instance into four divisions (D); which may either become isolated by the dissolution of their envelope, and may separate from each other in the condition of free primordial utricles (II), developing their cellulose investments at a future time; or may acquire their cellulose investments (as in the preceding case) before the solution of that of the original cell; and sometimes, even after the disappearance of this, and the formation of their own independent investments, they remain attached to each other at their beaked extremities, the primordial utricles being connected with each other by peduncular prolongations, and the whole compound body having the form of a cross +. This quaternary segmentation appears to be a more frequent mode of multiplication among the 'motile' cells, than the subdivision into two; although as we have seen, it is less common

in the 'still' condition. So, also, a primary segmentation of the entire endochrome of the 'motile' cells, into 8, 16, or even 32 parts, may take-place (E, F), thus giving-rise to as many minute primordial cells. These, when they are set-free, and possess active powers of movement, rank as 'zoospores' (G): which may either develop a loose cellulose investment or cyst, so as to attain the full dimensions of the ordinary motile cells (I, K), or may become clothed with a dense envelope, and lose their vibratile cilia, thus passing into the 'still' condition (A); and this last transformation may even take-place, before they are set-free from the envelope within which they were produced, so that they constitute a mulberry-like mass, which fills the whole cavity of the original cell, and is kept in motion by its cilia.

155. All these *varieties*, whose relation to each other has been clearly proved by watching the successional changes that make-up the history of this one Plant, have been regarded as constituting, not merely distinct *species*, but distinct *genera* of Animalcules; such as *Chlamydomonas*, *Euglena*, *Trachelomonas*, *Gyges*, *Gonium*, *Pandorina*, *Botryocystis*, *Urella*, *Syn-crypta*, *Monas*, *Astasia*, *Bodo*, and probably many others.* Certain forms, such as the 'motile' cells (I, K, L), appear in a given infusion, at first exclusively and then principally; they gradually diminish, become more and more rare, and finally disappear altogether, being replaced by the 'still' form. After some time, the number of the 'motile' cells again increases, and reaches, as before, an extraordinary amount; and this alternation may be repeated several times in the course of a few weeks. The process of segmentation is often accomplished with great rapidity. If a number of motile cells be

* In the above sketch, the Author has presented the facts described by Dr. Cohn, under the relation which they seemed to him naturally to bear; for the membrane which immediately surrounds the primordial utricle of the 'still' cells, appears to him to be essentially the same with the sacculated investment of the 'motile' form, since it differs only in its greater density, and in the absence of the interposed fluid. It is distinctly stated by Cohn, towards the conclusion of his Memoir, that the one like the other consists of cellulose, since both alike give the characteristic blue colour with a very dilute solution of iodine, and with moderately-diluted sulphuric acid; yet he speaks of what he terms the 'encysted zoospore' (I, K, L), as being formed by *one cell within another*, the outer cell having a true cell-membrane and aqueous contents, but being destitute of primordial utricle; whilst the inner cell has denser, coloured contents, but is without the true cell-membrane.—Having enjoyed, since the above was written, the opportunity of personally communicating with Dr. Cohn with regard to the question to which it refers, the Author is glad to be able to state, that Dr. Cohn's later observations have led him to adopt a view of the relationship of the 'still' and 'motile' forms, which is in essential accordance with his own.

transferred from a larger glass into a small capsule, it will be found, after the lapse of a few hours, that most of them have subsided to the bottom; in the course of the day, they will all be observed to be upon the point of subdivision; on the following morning, the divisional brood will have become quite free; and on the next, the bottom of the vessel will be found covered with a new brood of self-dividing cells, which again proceed to the formation of a new brood, and so on. The activity of motion and the activity of multiplication, seem to stand, in some degree, in a relation of reciprocity to each other; for the self-dividing process takes-place with greater rapidity in the 'still' cells, than in the 'motile.'

156. What are the precise conditions which determine the transition from one state to the other, cannot yet be precisely stated; but the influence of certain agencies can be predicted with tolerable certainty. Thus it is only necessary to pour the water containing these organisms, from a smaller and deeper into a larger and shallower vessel, at once to determine segmentation in numerous cells,—a phenomenon which is observable also in many other Protophytes. The 'motile' cells seem to be favourably affected by light, for they collect themselves at the surface of the water and at the edges of the vessel; but when they are about to undergo segmentation, or to pass into the 'still' condition, they sink to the bottom of the vessel, or retreat to that part of it in which they are least subjected to light. When kept in the dark, the 'motile' cells undergo a great diminution of their chlorophyll, which becomes very pale, and is diffused, instead of forming definite granules; they continue their movement, however, uninterruptedly, without either sinking to the bottom, or passing into the still form, or undergoing segmentation. A moderate warmth, particularly that of the vernal sun, is favourable to the development of the 'motile' cells; but a temperature of excessive elevation prevents it. Rapid evaporation of the water in which the 'motile' forms of *Protococcus* may be contained, kills them at once; but a more gradual loss, such as takes-place in deep glasses, causes them merely to pass into the 'still' form; and in this condition,—especially when they have assumed a red hue,—they may be completely dried-up, and may remain in a state of dormant vitality for many years. It is in this state that they are wafted-about in atmospheric currents, and that, being brought-down by the rain into pools, cisterns, &c., they may present themselves where none had been previously known to exist; and there, under favourable

circumstances, they may undergo a very rapid multiplication, and may maintain themselves until the water is dried-up, or some other change occurs which is incompatible with the continuance of their vital activity. They then very commonly become red throughout, the red colouring-substance extending itself from the centre towards the circumference, and assuming an appearance like that of oil-drops; and these red cells, acquiring thick cell-walls and a mucous envelope, float in flocculent aggregations on the surface of the water. This state seems to correspond with the 'winter spores' of other Protophytes; and it may continue until warmth, air, and moisture, cause the development of the red cells into the ordinary 'still' cells, green matter being gradually produced, until the red substance forms only the central part of the endochrome. After this occurs the cycle of changes which has been already described; and the Plant may pass through a long series of these, before it returns to the state of the red thick-walled cell, in which it may again remain dormant for an unlimited period.—Even this cycle, however, cannot be regarded as completing the history of the species before us; since it does not include the performance of any true Generative act. There can be little doubt that, in some stage of its existence, a 'conjugation' of two cells occurs, as in the preceding case; and the attention of observers should be directed to its discovery, as well as to the detection of other varieties in the condition of this interesting little Plant, which will be probably found to present themselves before and after the performance of that act.

157. From the composite motile forms of the preceding type, the transition is easy to the group of *Volvocineæ*,—an assemblage of minute Plants of the greatest interest to the Microscopist, on account both of the Animalcule-like activity of their movements, and of the great beauty and regularity of their forms. The most remarkable example of this group, is the well-known *Volvox globator* (Fig. 69), or 'globe-animalcule;' which is not uncommon in fresh-water pools, and which, attaining a diameter of 1-30th

FIG. 69.

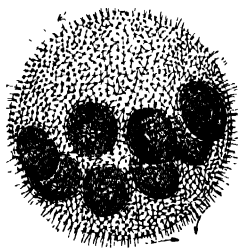
*Volvox Globator.*

of an inch, may be seen with the naked eye, when the drop containing it is held-up to the light, swimming through the water which it inhabits. Its onward motion is usually of a rolling kind; but it sometimes glides smoothly along, without turning on its axis; whilst sometimes, again, it rotates like a top, without changing its position. When examined with a sufficient magnifying power, the *Volvox* is seen to consist of a hollow sphere, composed of a very pellucid material, which is studded at regular intervals with minute green spots, and which is often (but not constantly) traversed by green threads connecting these spots together. From each of the spots proceed two long cilia; so that the entire surface is beset with these vibratile filaments, to whose combined action its movements are due. Within the external sphere, there may generally be seen from two to twenty other globes, of a darker colour, and of varying sizes; the smaller of these are attached to the inner surface of the investing sphere, and project into its cavity; but the larger lie freely within the cavity, and may often be observed, to revolve by the agency of their own ciliary filaments. After a time, the original sphere bursts, the contained sphericles swim-forth and speedily develop themselves into the likeness of that within which they have been evolved; their component particles, which are at first closely aggregated-together, being separated from each other by the interposition of the transparent pellicle.—It was long supposed that the *Volvox* was a *single* Animal; and it was first shown to be a *composite* fabric, made-up of a repetition of organisms in all respects similar to each other, by Prof. Ehrenberg; who, however, considered these organisms as *Monads*, and described them as each possessing a mouth, several stomachs, and an eye! Our present knowledge of their nature, however, leaves no doubt of their Vegetable character; and the peculiarity of their history renders it desirable to describe it in some detail.

158. Each of the so-called 'Monads' is in reality a somewhat flask-shaped mass of endochrome, about 1-3000th of an inch in diameter; consisting, as in the previous instances, of chlorophyll-granules, diffused through a colourless protoplasm (Fig. 70, I, L); and bounded by a layer of condensed protoplasm, which represents a primordial utricule, but is obviously far from having attained a membranous consistence. It is prolonged outwardly (or towards the circumference of the sphere) into a sort of colourless peak or proboscis, from which proceed two long vibratile cilia (L); and it is invested by a pellucid or 'hyaline' envelope (I, *d*) of considerable thickness,

the borders of which are flattened against those of other similar envelopes (E, *cc*), but which does not appear to have the tenacity of a true membrane. It is impossible not to recognize the precise similarity between the structure of this body, and that of the motile 'encysted' cell of *Protococcus pluvialis* (Fig. 68, κ); there is not, in fact, any perceptible difference between them, save that which arises from the regular aggregation, in *Volvox*, of the cells which normally detach themselves from one another in *Protococcus*. The presence of cellulose in the hyaline substance is not indicated, in the ordinary condition of *Volvox*, by the iodine and sulphuric acid test, though the use of 'Schulz's solution' gives to it a faint blue tinge; there can be no doubt of its existence, however, in the hyaline envelope of what has been termed *Volvox aureus*, which is in reality nothing but the 'winter spore' of *Volvox globator*. The cilia and endochrome, as in the motile forms of *Protococcus*, are tinged of a deep brown by iodine, with the exception of one or two particles in each cell, which, being turned blue, may be inferred to be starch; and when the contents of the cell are liberated, bluish flocculi, apparently indicative of the presence of cellulose, are brought into view by the action of sulphuric acid and iodine. All these re-actions are strictly *vegetable* in their nature.—When the cell is approaching maturity, its endochrome always exhibits one or more 'vacuoles' (Fig. 70, I, *a a*), of a spherical form, and usually about one-third of its own diameter; and these 'vacuoles' (which are the so-called 'stomachs' of Prof. Ehrenberg) have been observed by Mr. G. Busk to undergo a very curious rhythmical contraction and dilatation at intervals of about 40 seconds; the contraction (which seems to amount to complete obliteration of the cavity of the vacuole) taking-place rapidly or suddenly, whilst the dilatation is slow and gradual. This curious action ceases, however, as the cell arrives at its full maturity; a condition which seems to be marked by the greater consolidation of the primordial utricle, by the removal or transformation of some of the chlorophyll (the greater part of the colouring-matter contracting into a small irregular mass, which adheres to the bottom or side of the cell, leaving the rest of the cavity clear and transparent), and the formation of the red spot (*b*), which obviously consists, as in *Protococcus*, of a peculiar modification of chlorophyll.

159. Each mass of endochrome normally communicates with those in nearest proximity with it, by extensions of its own substance, which are sometimes single and sometimes

double (E, *b b*); and these connecting processes necessarily cross the lines of division between their respective hyaline investments. The thickness of these processes varies very considerably; for sometimes they are broad bands, and in other cases mere threads; whilst they are occasionally wanting altogether. This difference seems partly to depend upon the age of the specimen, and partly upon the abundance of nutriment which it obtains; for, as we shall presently see, the connection is most intimate at an early period, before the hyaline investments of the cells have increased so much as to separate the masses of endochrome to a distance from one another (B, C, D); whilst in a mature individual, in which this separation has taken place to its full extent, and the nutritive processes have become less active, the masses of endochrome very commonly assume an angular form, and the connecting processes are drawn-out into threads (as seen at E), or they retain their globular form, and the connecting processes altogether disappear. The influence of re-agents, or the infiltration of water into the interior of the hyaline investment, will sometimes cause the connecting processes (as in *Protococcus*, § 154), to be drawn-back into the central mass of endochrome; and they will also retreat on the mere rupture of the hyaline investment: from these circumstances it may be inferred, that they are not enclosed in any definite membrane. On the other hand, the connecting threads are sometimes seen as double lines, which seem like tubular prolongations of a consistent membrane, without any protoplasmic granules in their interior. It is obvious, then, that an examination of a considerable number of specimens, exhibiting various phases of conformation, is necessary to demonstrate the nature of these communications; but this may be best made-out by attending to the history of their development, which we shall now describe.

160. The spherical body of the young *Volvox* (Fig. 78, A) is composed of an aggregation of somewhat angular masses of endochrome (*b*), separated by the interposition of hyaline substance; and the whole seems to be enclosed in a distinctly membranous envelope, which is probably the distended hyaline investment of the primordial cell, within which, as will presently appear, the entire aggregation originated. In the midst of the polygonal masses of endochrome, one mass (*a*), rather larger than the rest, is seen to present a circular form; and this, as will presently appear, is the originating cell of what is hereafter to become a new sphere. The growing *Volvox* at first increases in size, not only by the interposition of new

FIG. 70.

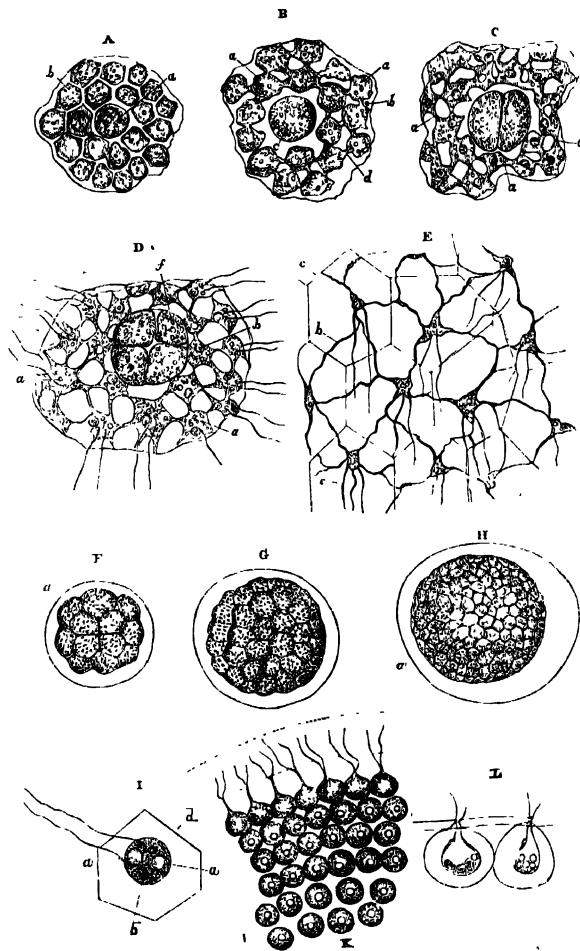

Various stages in the Development of *Volvox Globator*.

hyaline substance between its component masses of endochrome, but also by an increase in these masses themselves (*B, a*), which come into continuous connection with each other by the coalescence of processes (*b*) which they severally put forth; at the same time, an increase is observed in the size of the globular cell (*c*), which is preliminary to its binary subdivision. A more advanced stage of the same developmental process is seen at *c*; in which the connecting processes (*a a*) are so much increased in size, as to establish a most intimate union between the masses of endochrome, although the increase of the intervening hyaline substance carries these masses apart from one another; whilst the endochrome of the central globular cell has undergone segmentation into two halves. In the stage represented at *D*, the masses of endochrome have been still more widely separated by the interposition of hyaline substance; each has become furnished with its pair of ciliary filaments; and the globular cell has undergone a second segmentation. Finally at *E*, which represents a portion of the spherical wall of a mature Volvox, the endochrome-masses are observed to present a more scattered aspect, partly on account of their own reduction in size, and partly through the interposition of a greatly-increased amount of hyaline substance, which is secreted from the surface of each mass; and that portion which belongs to each cell, standing to the endochrome-mass in the relation of the cellulose coat of ordinary cells to their primordial utricle, is frequently seen to be marked-out from the rest by delicate lines of hexagonal areolation (*c, c*), which indicate the boundaries of each. Of these it is often difficult to obtain a sight, a nice management of the light being usually requisite with fresh specimens; but the prolonged action of water (especially when it contains a trace of iodine), or of glycerine, will often bring them into clear view. The prolonged action of glycerine, moreover, will often show that the boundary lines are double, being formed by the coalescence of two contiguous cell-walls; and they sometimes retreat from each other so far, that the hexagonal areolæ become rounded.

161. As the primary sphere approaches maturity, the secondary germ, whose origin has been traced from the beginning, also advances in development; its contents undergoing multiplication by successive segmentations, so that we find it to consist of 8, 16, 32, 64, and still more numerous divisions, as shown in Fig. 70, *F, G, H*. Up to this stage, at

which first the sphere appears to become hollow, it is retained within the hyaline envelope of the cell, within which it has been produced; a similar envelope can be easily distinguished, as shown at κ , just when the segmentation has been completed, and at that stage the cilia pass into it, but do not extend beyond it; and even in the mature *Volvox*, it continues to form an investment around the hyaline envelopes of the separate cells, as shown at L . It seems to be by the adhesion of the hyaline investment of the new sphere to that of the old, that the secondary sphere remains for a time attached to the interior wall of the primary; at what exact period, or in what precise manner, the separation between the two takes place, has not yet been determined. At the time of the separation, the developmental process has generally advanced as far as the stage represented at A ; the foundation of one or more tertiary spheres being usually distinguishable in the enlargement of certain of its cells.—And thus the cycle of development is completed, in so far as regards the increase of cells by subdivision. But, as already pointed out, the life-history of no organism can be considered as complete, unless it includes an act of ‘conjugation,’ or some other form of the true Generative process; and as none such has yet been observed in *Volvox*, there is strong ground to suspect that we are not acquainted with its whole life, but that conjugation may occur in some condition not yet known to us, which may only present itself after a long succession of repetitions of that process of gemination, by which the *Volvox*-spheres are multiplied and reproduced.

162. Certain curious varieties, however, occasionally present themselves in the preceding cycle. Thus, the young *Volvox*-globe which has attained the size and has undergone the degree of segmentation indicated at G or H , sometimes becomes at first deep-green and then yellow; its hyaline envelope acquires an unusual firmness, and a second coat is formed within the first, the coloured contents undergoing some retraction; and eventually a considerable space intervenes between the two coats, which is occupied by a clear fluid. The protoplasmic contents of the inner envelope consist chiefly of starch-grains, mixed with a bright-yellow and apparently-oily fluid. In this and other respects, the body in question corresponds so closely with the ‘still’ or ‘winter’ spore of other Protophytes, which is adapted to resist influences that are fatal to the more actively-vegetating forms

of these organisms, that it seems most probably (as was first suggested by Mr. G. Busk) to stand in this relation to *Volvox globator*, although the ultimate mode of its development is not known; and thus the *Volvox aureus*, as the kind that produces these golden-yellow spheres has been designated, is nothing else than an ordinary *Volvox* preparing its brood for the winter-state of inactivity. The *Volvox stellatus* of Ehrenberg, again, seems to be nothing more than a variety of the same specific type; its peculiarity consisting in the presence of numerous conical eminences, formed of the hyaline substance only, on the secondary globules, giving them a stellate aspect. The endochrome-segments resemble those of the globules of *Volvox aureus*, both in colour and composition; and these two forms of secondary globules, the stellate and the smooth, having been observed by Mr. Busk to coexist in the very same sphere, are certainly to be regarded as varieties of one and the same type.*—The same excellent observer has also pointed out the probability, that the body designated by Prof. Ehrenberg *Sphaerosira volvox*, is an ordinary *Volvox* in a different phase of development. For it does not present any marked feature of dissimilarity, except that a large proportion of the green cells, instead of being single (as in the ordinary form of *Volvox*) save where they are developing themselves into young spheres, are very commonly double, quadruple, or multiple; and the groups of ciliated cells thus produced, instead of constituting a hollow sphere, form by their aggregation discoid bodies, of which the separate fusiform cells are connected at one end, whilst at the other they are free, each being furnished with a single cilium. These clusters separate themselves from the primary sphere, and swim forth freely, under the forms which have been designated as *Uvella* and *Syncrypta* by Prof. Ehrenberg. The further history of these

* "In the month of August last," says Mr. Busk (Op. cit., p. 41), "when, in a certain pond on Blackheath, there was the most incredible abundance of *Volvox*, so great, in fact, as to render the water at the lee-side of the pond in certain spots of a deep green-colour, and to cause it to afford, when collected, a very strong herbaceous or confervoid smell, the majority of the plants exhibited the *stellate* form of spores, or rapidly acquired spores of that character, and very many were in, or soon assumed, the form of *V. aureus*. They seemed, in fact, to be entering on their hibernating state. Many among them, however, though all small and starved-looking, were of the common kind; in all these, Prof. Williamson's hexagonal areolation was very distinct. In the month of October, however, upon returning to the same pond, I was able to find very few *Volvoes* at all, and all of the usual kind; in none of these could I detect the least appearance of the same arrangement." Prof. Williamson has noticed analogous variations, in the specimens taken at different seasons from one locality (Op. cit., p. 56).

has not been traced; and it does not seem improbable that more than one intermediate stage may be passed through, before a return is made to the type of *Volvox globator*.*

163. *Desmidiaceæ*.—Among the simplest tribes of Proto-phytes, there are two which are of such peculiar interest to the Microscopist, as to need a special notice; these are the *Desmidiææ* (or more properly *Desmidiaceæ*), and the *Diatomaceæ*. Both of them have been ranked by Ehrenberg, and by many other Naturalists, as Animalcules; but the fuller knowledge of their life-history, and the more extended acquaintance with the parallel histories of other simple forms of Vegetation, which have been gained during the last ten years, can scarcely be considered by judges who are at once competent and unprejudiced, as otherwise than decisive in regard to their vegetable nature.—The *Desmidiaceæ* are minute plants of a green colour, growing in fresh water; generally speaking, the cells are independent of each other (Figs. 71, 75, 76); but sometimes those which have been formed by duplicative subdivision from a single primordial cell, remain adherent one to another in linear series, so as to form a filament (Fig. 77); whilst in other instances, they constitute beautiful star-like groups (Figs. 73, 74). This tribe is distinguished by two peculiar features; one of these being the semblance of a subdivision into two symmetrical halves, which is seen in the cells of most species, and which is sometimes so decided as to have led to the belief that the cell is really double (Fig. 75, A), though in other cases it is merely indicated by a slight notch on one side (as in the marginal cells of Fig. 73, A, E); whilst the other is the frequency of projections from their surface, which are sometimes short and inconspicuous (Fig. 75), but are often elongated into spines, presenting a very symmetrical

* The doctrine of the *vegetable* nature of the *Volvox*, which had been suggested by Siebold, Braum, and other German Naturalists, was first distinctly enunciated by Prof. Williamson, on the basis of the history of its development, in the "Transactions of the Philosophical Society of Manchester," vol. ix. Subsequently Mr. C. B. Clark, adding additional evidence of the *Vegetable*

"Further Elucidations" in the same Transactions.—The Author has endeavoured to state the *facts* in which both these excellent observers agree (and which he has himself had the opportunity of verifying), with the *interpretation* that seems to him most accordant with the phenomena presented by other Proto-phytes; and he believes that this interpretation harmonizes with what is most essential in the doctrines of both, their differences having been to a certain degree reconciled by their mutual admissions.

arrangement (Fig. 71). These projections are generally formed by the outer coat alone, which possesses an almost

FIG. 71.

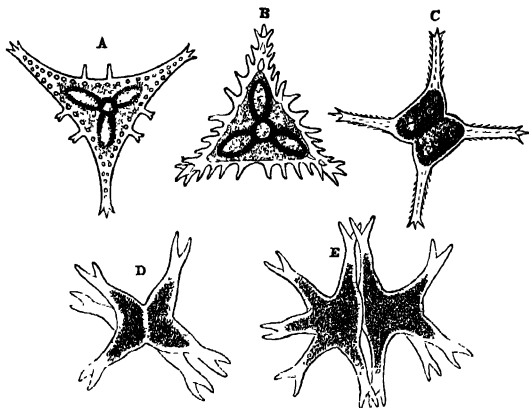

Various species of *Staurostrum* :—A, *S. vestitum* ; n, *S. aculeatum* ;
c, *S. paradoxum* ; D, E, *S. brachiatum*.

horny consistence, so as to retain its form after the discharge of its contents (Figs. 74,E, 75,B), but which does not include any mineral ingredient, either calcareous or siliceous, in its composition. This outer coat is surrounded by a very transparent sheath of gelatinous substance, which is sometimes very distinct (as shown in Fig. 77), whilst in other cases its existence is only indicated by its preventing the contact of the cells. The outer coat encloses an inner membrane, which is not always, however, closely adherent to it ; and this immediately surrounds the coloured substance which occupies the whole interior of the cell. It is quite certain that the Desmidiaceæ, like the Confervoid Plants in general, grow at the expense of the inorganic elements which surround them, instead of depending upon other living beings for their subsistence ; and that they decompose carbonic acid, and give-off oxygen, under the influence of sun-light. They have the power of generating from these materials the organic compounds which they require for their own development ; and these are such as are

formed by other undoubted Protophytes, as is proved by the application of the appropriate tests. Thus the outer coat is coloured blue by sulphuric acid and iodine, and is therefore composed of cellulose. The 'endochrome' derives its colour from the same green substance, 'chlorophyll,' as that which imparts it to Plants generally; and this is mingled with a protoplasmic fluid, in which 'vacuoles' are frequently to be seen. At certain stages in the growth of these plants, as in other Algæ, starch is produced; the presence of which is made obvious by the application of iodine. There is no one essential point, therefore, in which the *Desmidiaceæ* differ from other Protophytes, or really approach the Animal kingdom. Some of the arguments that have been advanced in support of their Animal affinities,—such as their multiplication by transverse subdivision, and their generation by a process of conjugation,—are really, now that the physiology of the unicellular plants is better understood, much more strongly indicative of their Vegetable alliances. The assertion of Prof. Ehrenberg, that *Closterium* possesses organs which it protrudes through apertures in its extremities, and keeps in continual motion, is (like too many of his statements) simply untrue. And although many of these plants have a power of slowly changing their place, so that they approach the light side of the vessel in which they are kept, and will even traverse the field of the microscope under the eye of the observer, yet this faculty is in no respect different from that which many undoubted Protophytes (such as *Oscillatoria*, § 196) possess.

164 A very peculiar feature which has recently attracted much attention, is the *circulation of fluid* which may be seen to take-place in the *Closterium*, both between its 'cellulose' coat and its 'primordial utricle,' and within the latter; and the *ciliary action* by which, according to the testimony of some good observers, this circulation is maintained. It is not difficult to distinguish this movement along the convex and concave edges of the cell of any vigorous specimen of *Closterium*, if it be examined under a magnifying power of 250 or 300 diameters; and a peculiar whirling movement may also be distinguished, in the large rounded space which is left at each end of the cell by the retreat of the endochrome from the primordial utricle (Fig. 72, A, B). According to Mr. S. G. Osborne, however, by using the 'Rainey moderator' (§ 74) with direct sun-light and an achromatic condenser, and by increasing the power to about

500 diameters (Mr. Ross's objective of 1-6th in., with a deep eye-piece, being the combination employed), a very distinct action of cilia may be discerned, both along the inner edge of

FIG. 72.

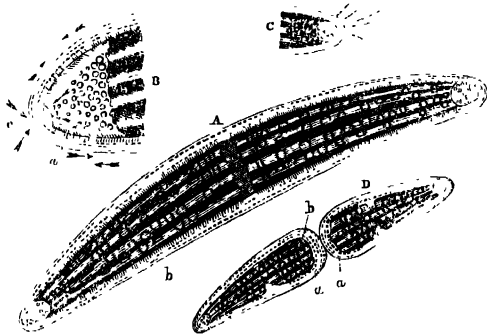

Economy of *Closterium lunula*:—A, frond showing central separation at *a*, in which large globules, *b*, are not seen;—B, one extremity enlarged, showing at *a* the double row of cilia, at *b* the internal current, and at *c* the external current;—c, external jet produced by pressure on the frond;—D, frond in a state of self-division.

the primordial utricle, between this membrane and the endochrome, and along its outer edge, beneath the cellulose coat; the action being in opposite directions in these two situations, and producing two opposite currents. By careful focussing, the circulation may be seen in broad streams over the whole surface of the endochrome; and these streams detach and carry with them, from time to time, little oval or globular bodies (A, *b*), which are put-forth from it, and which are carried by the course of the flow to the chambers at the extremities, where they join a crowd of similar bodies (B). In each of these chambers, a current may be seen from the somewhat abrupt termination of the endochrome, towards the obtuse end of the cell (as indicated by the interior arrows); and the globules it contains are kept in a sort of twisting movement by the action of the cilia on the *inner* side of the primordial utricle, which can here be distinctly seen as at *a*. Other currents are seen externally to it, which seem to be

kept-up by the *outer* set of cilia; these form three or four distinct courses of globules, passing towards and away-from *c* (as indicated by the outer arrows), where they seem to encounter a fluid jetted towards them through an aperture in the primordial utricle at the apex of the chamber; and here some communication between the inner and the outer currents takes-place. A corresponding aperture seems also to exist in the outer cellulose coat; for if the endochrome be forced by pressure into closer proximity than usual to the obtuse termination of the cell, the current from its extremity may be seen to spread into the surrounding fluid.—This circulation is by no means peculiar to *Closterium*; having been seen by Mr. Osborne in many other Desmidiaceæ, in several of which he has also detected what he believes to be ciliary action.*

165. When the single cell has come to its full maturity, it commonly multiplies itself by *duplicative subdivision*; but the plan on which this takes-place is often peculiarly modified, in order to maintain the symmetry characteristic of the tribe. In a cell of the simple cylindrical form of those of *Didymoprium* (Fig. 77), little more is necessary than the separation of the two halves, and the formation of a partition between them by the infolding of the primordial utricle, according to the plan already described (§ 150); and in this manner, out of the lowest cell of the filament *A*, a double cell *B* is produced. But it will be observed that each of the simple cells has a bifid wart-like projection of the cellulose coat on either side, and that the half of this projection, which has been appropriated by each of the two new cells, is itself becoming bifid, though not symmetrically; in process of time, however, the increased development of the sides of the cells which remain in contiguity with each other, brings-up the smaller projections to the dimensions of the larger, and the symmetry of the cell is restored.—In *Closterium* (Fig. 72, *v*), the two halves of the endochrome first retreat from one another at the middle line, and a constriction takes-place round the cellulose coat; this constriction deepens until it becomes an hour-glass contraction, which proceeds until the cellulose coat entirely

* See Mr. S. G. Osborne's communications to the "Quarterly Journal of Microscopical Science," vol. ii. p. 234, and vol. iii. p. 54.—Although the *Circulation* is an unquestionable fact, it may be doubted whether the appearance of *Ciliary action* is not an optical illusion, due to the play of the peculiar light employed, among the moving particles of the fluid. See Mr. Wenham's paper on the Circulation in the Leaf-Cells of *Anacharis*, in the same Journal, vol. iii. p. 278.

closes-round the primordial utricle of the two segments; in this state, one half commonly remains passive, whilst the other has a motion from side to side, which gradually becomes more active; and at last one segment quits the other with a sort of jerk. At this time, a constriction is seen across the middle of the primordial utricle of each segment; but there is still only a single chamber, which is that belonging to one of the extremities of the original entire frond. The globular circulation, for some hours previously to subdivision, and for a few hours afterwards, runs quite round the obtuse end *a* of the endochrome; but gradually a chamber is formed, like that at the opposite extremity, by a separation between the cellulose coat and the primordial utricle; whilst at the same time, the obtuse form becomes changed to a more elongated and contracted shape. Thus, in five or six hours after the separation, the aspect of each extremity becomes the same, and each half resembles the perfect frond in whose self-division it originated; and the globular circulation within the newly formed chamber comes into connection with the general circulation, some of the free particles which are moving over the surface of the primordial utricle, being drawn into its vortex and tossed-about in its eddies.—The process is seen to be performed after nearly the same method in *Staurastrum* (Fig. 71, D, E); the division taking-place across the central constriction, and each half gradually acquiring the symmetry of the original.—In such forms as *Cosmarium*, however, in which the cell consists of two lobes united together by a narrow isthmus (Fig. 75), the division takes-place after a different method; for the central region of the isthmus expands, and displays two globular enlargements, separated from each other and from the two halves of the original cell (which their interposition carries apart) by a narrow neck; and these enlargements increase, until they assume the appearance of the half-segments of the original cell. In this state, therefore, the plant consists of a row of four segments, lying end to end, the two old ones forming the extremes, and the two new ones (which do not usually acquire the full size or the characteristic markings of the original, before the division occurs) occupying the intermediate place. At last the central fusion becomes complete, and two bipartite fronds are formed, each having one old and one young segment; the young segment, however, soon acquires the full size and characteristic aspect of the old one; and the same process, the whole of which may take-place

within twenty-four hours,* is repeated ere long. In *Spherososma*, the cells thus produced remain connected in rows within a gelatinous sheath, like those of *Didymoprium* (Fig. 77); and different stages of the process may commonly be observed in the different parts of any one of the filaments thus formed. In any such filament, it is obvious that the two oldest segments are found at its opposite extremities, and that each subdivision of the intermediate cells must carry them further and further from each other. This is a very different mode of increase from that of the *Confervaceæ*, in which the terminal cell alone undergoes subdivision (§ 198), and is consequently the last-formed.

166. Many of the *Desmidiaceæ* multiply after another method; namely, by the subdivision of their endochrome into a multitude of granular particles, termed *gonidia*; which are set-free by the rupture of the cell-wall, and of which every one may develope itself into a new cell. These 'gonidia' may be endowed with cilia, and may possess an active power of locomotion, in which case they are known as 'zoospores;' or they may be destitute of any such power, and may become enclosed in a firm cyst or envelope that seems destined for their long-continued preservation, in which case they are designated as 'resting spores.'—The movement of the zoospores, first within the cavity of the cell that gives origin to them, and afterwards externally to it, has frequently been observed in the various species of *Cosmarium*; and has been described under the title of 'the swarming of the granules,' from the extraordinary resemblance which the mass of moving particles bears to a swarm of bees. The subsequent history of their development, however, has not been fully traced-out; and this is a point to which the attention of Microscopists should be specially directed.—In *Pediastrum*, a plant whose frond normally consists of a cluster of cells, the zoospores are not emitted separately, but those formed by the subdivision of the endochrome of one cell, which may be 4, 8, 16, 32, or 64 in number, escape from the parent-frond still enclosed in the inner tunic of the cell; and it is within this that they develope themselves into a cluster, resembling that in which they originated. This is well shown in the accompany-

* See the observations of Mrs. Herbert Thomas on *Cosmarium margaritifera*, in "Microscopical Transactions," Second Series, vol. iii. pp. 33-36. Several varieties in the mode of subdivision are described in this short record of long-continued observations, as of occasional occurrence.

ing series of illustrations of the developmental history of *Pediastrum granulatum* (Fig. 73, A-F), a species whose frond

FIG. 73.

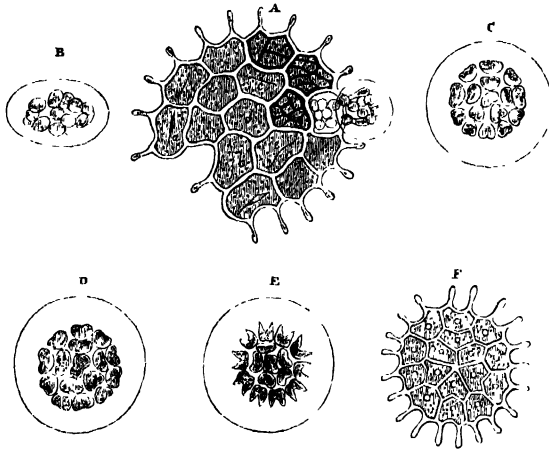

Various phases of development of *Pediastrum granulatum*.

normally consists of 16 cells, but may be composed of either of the just-mentioned multiples or sub-multiples of that number. At A is seen an old disk, of irregular shape, nearly emptied by the emission of its gonidia, which had been seen to take-place, within a few hours previously, from the cells *a, b, c, d, e*; most of the empty cells exhibit the cross slit through which their contents had been discharged; and where this does not present itself on the side next the observer, it occurs on the other. Three of the cells still possess their coloured contents, but in different conditions. One of them exhibits an early stage of the subdivision of the endochrome, namely into two halves, one of which already appears halved again. Two others are filled by sixteen very closely-crowded gonidia, only half of which are visible, as they form a double layer. Besides these, one cell is in the very act of discharging its gonidia; nine of which have passed-forth from its cavity, though still enveloped in a vesicle formed by the extension of

its innermost membrane; whilst seven yet remain in its interior. The new-born family, as it appears immediately on its complete emersion, is shown at B; the gonidia are actively moving within the vesicle; and they do not as yet show any indication either of symmetrical arrangement, or of the peculiar form which they are subsequently to assume. Within a quarter of an hour, however, the gonidia are observed to settle-down into one plane, and to assume some kind of regular arrangement, most commonly that seen at C, in which there is a single central body, surrounded by a circle of five, and this again by a circle of ten; they do not, however, as yet adhere firmly together. The gonidia now begin to develop themselves into new cells, increase in size, and come into closer approximation (D); and the edge of each, especially in the marginal row, presents a notch, which foreshadows the production of its characteristic 'horns.' Within about four or five hours after the escape of the gonidia, the cluster has come to assume much more of the distinctive aspect of the species, the marginal cells having grown-out into horns (E); still, however, they are not very closely connected with each other; and between the cells of the inner row, considerable spaces yet intervene. It is in the course of the second day, that the cells become closely applied to each other, and that the growth of the horns is completed, so as to constitute a perfect disk, like that seen at F, in which, however, the arrangement of the interior cells does not follow the typical plan.

167. The varieties which present themselves, indeed, both as to the number of cells in each cluster, and the plan on which they are disposed, are such as to baffle all attempts to base specific distinctions on such grounds; and the more attentively the life-history of any one of these plants is studied, the more evident does it appear that many reputed species have no real existence. Some of these, indeed, are nothing else than mere transitory forms; thus it can scarcely be doubted that the specimen represented in Fig. 74, D, under the name of *Pediastrum pertusum*, is in reality nothing else than a young frond of *P. granulatum*, in the stage represented in Fig. 73, E, but consisting of 32 cells. On the other hand, in Fig. 74, E, we see an emptied frond of *P. granulatum*, exhibiting the peculiar surface-marking from which the name of the species is derived, but composed of no more than 8 cells. And instances every now and then occur, in which the frond consists of only 4 cells, each of them presenting the two-

horned shape. So, again, in Fig. 74, B and C, are shown two varieties of *Pediastrum biradiatum*, whose frond is normally composed of sixteen cells; whilst at A is figured a form which

FIG. 74.

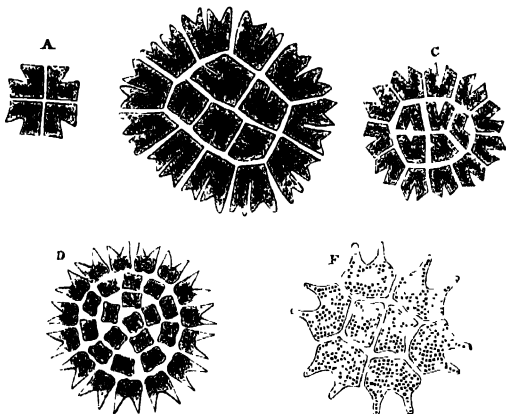

Various species (?) of *Pediastrum*:—A, *P. tetras*; B, C, *P. biradiatum*; D, *P. pertusum*; E, empty frond of *P. granulatum*.

is designated as *P. tetras*, but which may be strongly suspected to be merely a 4-celled variety of B and C.

168. Many similar cases might be cited; and the Author would strongly urge those Microscopists who have the requisite time and opportunities, to apply themselves to the determination of the *real species* of this group, by studying the entire life-history of whatever forms may happen to lie within their reach, noting all the varieties which present themselves among the offsets from any one stock. It must not be forgotten that this process of *multiplication* is analogous to the propagation of the higher Plants by budding, and to the subsequent separation of the buds, either spontaneously, or by the artificial operations of grafting, layering, &c.; and just as in all these cases, the particular *variety* is propagated, whilst only the characters of the *species* are transmitted by the true generative operation to the descendants raised from seed, so does it come

to pass that the characters of any particular variety which may arise among these unicellular Plants, are diffused by the process of duplicative subdivision, amongst vast multitudes of so-called individuals. Thus it happens that, as Mr. Ralfs has remarked, "one pool may abound with individuals of *Staurastrum dejectum* or *Arthrodesmus incus*, having the mucro curved outwards; in a neighbouring pool, every specimen may have it curved inwards; and in another, it may be straight. The cause of the similarity in each pool no doubt is, that all its plants are offsets from a few primary fronds." Hence the universality of any particular character, in all the plants of one gathering, is by no means sufficient to entitle these to take rank as a distinct species; since they are, properly speaking, but repetitions of the same form by a process of simple multiplication, really representing, in their entire aggregate, the one plant or tree that grows from a single seed.*

—In the genus *Celastrum*, the frond of which, like that of *Pediastrum*, is composed of clusters of cells, the endochrome subdivides into segments, as if for the formation of zoospores; but no motion takes place. These segments acquire cellulose coats, and arrange themselves within the parent-cells according to the typical pattern; and then the wall of the parent-cell splits and peels-off, leaving them as the foundation of a new cluster (Pringsheim).—A somewhat parallel phenomenon has been observed and figured in *Closterium* by Focke; the entire endochrome being retracted from the walls, and breaking-up into a number of globules, every one of which acquires a very firm envelope, resembling that of the 'resting-spores' or 'winter-spores' of many other Protophytes. Probably the following observation of Mr. Jenner's refers to a more limited production of these 'resting-spores':—"In all the Desmidiaceæ, but especially in *Closterium* and *Micrasterias*, small, compact, seed-like bodies of a blackish colour are at times to be met with. Their situation is uncertain, and their number varies from one to four. In their immediate neighbourhood the endochrome is wanting, as if it had been required to form them; but in the rest of the frond it retains its usual colour and appearance." It seems likely that, when thus enclosed in a firm cyst, the gonidia are more capable of preserving their vitality, than they are when destitute of such a protection;

* For a discussion of the question what really constitutes *individuality* in this and similar cases, see the Luthor's "Principles of Comparative Physiology," Chap. xi., Section 2

and that in this condition they may be taken-up and wafted through the air, so as to convey the species into new localities.

169. The proper Generative process in the *Desmidiaceæ* is always accomplished by the act of 'conjugation'; and this takes place after a manner very different from that which we have seen

FIG. 75.

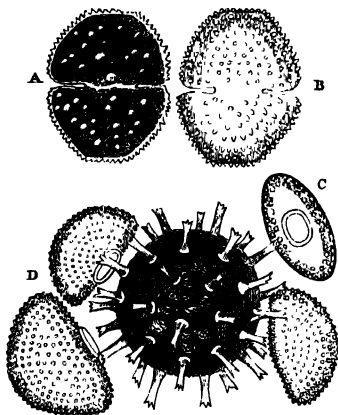

Cosmarium botrytis:—A, mature frond; B, empty frond; C, transverse view; D, sporangium with empty fronds.

to occur in *Palmoglaea*. For each cell here possesses, it will be recollected, a firm external envelope, which cannot enter into coalescence with that of any other; and this membrane dehisces more or less completely, so as to separate each of the conjugating cells into two valves (Fig. 75, C, D; Fig. 76, C). The contents of each cell, being thus set-free, without (as it appears) any distinct investment, blend with those of the other; and a mass is formed by their union, which soon acquires a truly membranous envelope.* This envelope is at first very delicate, and is filled with green and granular contents; by degrees the envelope acquires increased thickness, and the contents of the spore-cell become brown or red. The surface of the *sporangium*, as this body is now termed, is sometimes smooth, as in *Closterium* and its allies (Fig. 76), and in the *Desmidiææ* proper (Fig. 77); but in the *Cosmarieææ*, it acquires a granular, tuberculated, or even spinous surface (Fig. 75), the spines being sometimes simple and sometimes forked at their extremities.†

* In *Closterium lineatum*, as in many of the *Diatomaceæ* (§ 178), the act of conjugation gives origin to two sporangial cells.

† Bodies precisely resembling these, and almost certainly to be regarded as of this kind, are often found fossilized in flint, and have been described by Ehrenberg under the name of *Xanthidia*.

170. The mode in which conjugation takes place in the filamentous species constituting the *Desmidiæ* proper, is, how-

FIG. 76.

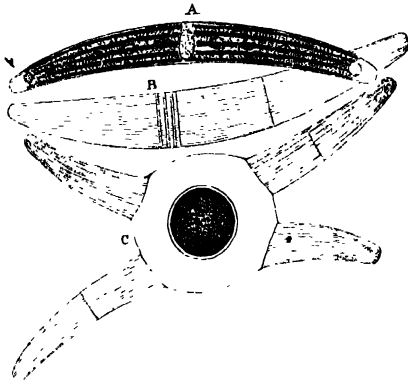

Closterium striatolum —A, ordinary frond; n, empty frond; c, two fronds in conjugation.

ever, in many respects different. The filaments first separate into their component joints; and when two cells approach in conjugation, the outer cell-wall of each splits or gapes at that part which adjoins the other cell, and a new growth takes place, which forms a sort of connecting tube, uniting the cavities of the two cells (Fig. 77, D, E). Through this tube the entire endochrome of one cell passes over into the cavity of the other (D), and the two are commingled so as to form a single mass (E), as is the case in many of the *Conjugatææ* (§ 199). The joint which contains the sporangium can scarcely be distinguished at first (after the separation of the empty cell), save by the greater density of its contents; but the proper coats of the sporangium gradually become more distinct, and the enveloping cell-wall disappears.—The subsequent history of the sporangia is still obscure; since, although it cannot be doubted that they give origin to new plants resembling those by whose conjugation they are formed, it is not known whether each sporangium in the first instance develops a single cell, or a brood of cells. The latter seems, from the

observations of Jenner and Focke, to be the case with *Closterium*; whilst those of Mrs. H. Thomas (loc. cit.) indicate

FIG. 77.

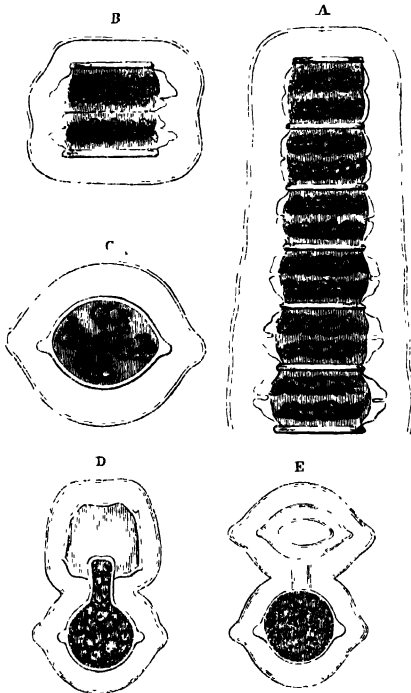

Didymoprium Grevillii—A, portion of filament, surrounded by gelatinous envelope, n, dividing joint; c, single joint viewed transversely; d, two cells in conjugation; e, formation of sporangium.

that it is likewise in *Cosmarium*, whose sporangium has been seen by her to emit large numbers of bodies resembling zoospores. This part of the history of the group is yet involved in much mystery; more especially since, according to the observations of Mr. Ralfs, there are several *Desmidiaceæ* which never make their appearance in the same pools for two

years successively, although their sporangia are abundantly produced,—a circumstance which would seem to indicate that their sporangia give origin to some different forms. It is a subject, therefore, to which the attention of Microscopists cannot be too sedulously directed.

171. The Desmidiaceæ are not found in running streams, unless the motion of the water be very slow; but are to be looked-for in standing, but not stagnant waters. Small shallow pools that do not dry up in summer, especially in open exposed situations, such as boggy moors, are most productive. The larger and heavier species commonly lie at the bottom of the pools, either spread-out as a thin gelatinous stratum, or collected into finger-like tufts. By gently passing the fingers beneath these, they may be caused to rise towards the surface of the water, and may then be lifted-out by a tin box or scoop. Other species form a greenish or dirty cloud upon the stems and leaves of other aquatic plants; and these also are best detached by passing the hand beneath them, and 'stripping' the plant between the fingers, so as to carry-off upon them what adhered to it. If, on the other hand, the bodies of which we are in search should be much diffused through the water, there is no other course than to take it up in large quantities by the box or scoop, and to separate them by straining through a piece of linen. At first nothing appears on the linen but a mere stain or a little dirt; but by the straining of repeated quantities, a considerable accumulation may be gradually made. This should be then scraped-off with a knife, and transferred into bottles with fresh water. If what has been brought up by hand be richly charged with these forms, it should be at once deposited in a bottle; this at first seems only to contain foul water; but by allowing it to remain undisturbed for a little time, the Desmidiaceæ will sink to the bottom, and most of the water may then be poured-off, to be replaced by a fresh supply. If the bottles be freely exposed to solar light, these little plants will flourish, apparently as well as in their native pools; and their various phases of multiplication and reproduction may be observed during successive months or even years.—If the pools be too deep for the use of the hand and the scoop, a collecting-bottle attached to a stick (§ 143) may be employed in its stead. The 'ring-net' may also be advantageously employed, especially if it be so constructed as to allow of the ready substitution of one piece of muslin for another (§ 143). For by using several pieces of previously-wetted muslin in succession, a

large number of these minute organisms may be separated from the water; the pieces of muslin may be brought home, folded-up in wide-mouthed bottles, separately, or several in one, according as the organisms are obtained from one or from several waters; and they are then to be opened-out in jars of filtered river-water, and exposed to the light, when the Desmidiaceæ will detach themselves from it.

172. *Diatomaceæ*.—Notwithstanding the very close affinity, which, as will be presently shown, exists between this group and the preceding, many Naturalists who do not hesitate in regarding the Desmidiaceæ as Plants, persist in referring the Diatomaceæ to the Animal kingdom. For this separation, no valid reason can be assigned; the curious movements which the Diatomaceæ exhibit, being certainly not of a nature to indicate the possession of any truly-animal endowment; and all their other characters being unmistakably vegetable. Like the Desmidiaceæ, they are *simple cells*, having a firm external coating, within which is included a mass of endochrome whose superficial layer seems to be consolidated into a sort of primordial utricle. The external coat, however, though it seems to have a basis of organic membrane,* is consolidated by *silex*: the presence of which in this situation is one of the most distinctive characters of the group. The endochrome, instead of being bright-green, is of a yellowish-brown; and its peculiar colour seems to be in some degree dependent upon the presence of *iron*, which is assimilated by the plants of this group, and which may be detected even in their colourless silicified envelopes. The colouring substance appears to be a modification of ordinary chlorophyll; it takes a green or greenish-blue tint with sulphuric acid; and often assumes this hue in drying. The endochrome consists, as in other Plants, of a viscid protoplasm, in which float the granules of colouring matter. In the ordinary condition of the cell, these granules are diffused through it with tolerable uniformity, except in the central spot which is occupied by a *nucleus*; round this nucleus they commonly form a ring, from which radiating

* A membrane bearing all the markings of the siliceous envelope has been found by Prof. Bailey to remain, after the removal of the silex by hydrofluoric acid; and this membrane seems to have been presumed by him, as also by Prof. W. Smith, to lie beneath the siliceous envelope, and to *secrete* this on its surface as a sort of epidermis. The Author agrees, however, with the authors of the "Micrographic Dictionary" (p. 200), in considering it much more likely that this membrane is the proper 'cellulose coat' *interpenetrated* by silex; especially since it has been found by Schmidt, that after removing the protoplasm of *Frustula salina* by potash, and the oil by ether, a substance remained identical in composition with the cellulose of Lichens.

lines of granules may be seen to diverge into the cell-cavity. At certain times, oil-globules are observable in the protoplasm; these seem to represent the starch-granules of the Desmidiaceæ (§ 163) and the oil-globules of other Protophytes (§ 151). A distinct movement of the granular particles of the endochrome, closely resembling the circulation of the cell-contents of the Desmidiaceæ (§ 164), has been noticed by Prof. W. Smith in some of the larger species of Diatomaceæ, such as *Surirella biseriata*, *Nitzschia scalaris*, and *Campylodiscus spiralis*; and although this movement has not the regularity so remarkable in the preceding group, yet its existence is important, as confirming the conclusion that each Diatom is a single cell (the endochrome moving freely from one part of its interior to another), and that it does not contain in its interior the aggregation of separate organs which have been imagined to exist in it.

173. The Diatomaceæ seem to have received their name from the readiness with which those forms that grow in coherent masses (which were those with which Naturalists first became acquainted) may be cut or broken-through; hence they have been also designated by the vernacular term 'brittle-worts.' Of this we have an example in the common *Diatoma* (Fig. 94), whose component cells (which in this tribe are usually designated as *frustules*) are sometimes found adherent side by side (as at *b*) so as to form filaments, but are more commonly met-with in a state of partial separation, remaining connected at their angles only (usually the *alternate* angles of the contiguous frustules) so as to form a zig-zag chain. A similar cohesion at the angles is seen in the allied genus *Grammatophora* (Fig. 95), in *Isthmia* (Fig. 96), and in many other Diatoms; in *Biddulphia* (Fig. 81), there even seems to be a special organ of attachment at these points. In some Diatoms, however, the cells produced by successive acts of binary subdivision, habitually remain adherent one to another; and thus are produced filaments or clusters of various shapes. Thus it is obvious that, when each cell is a short cylinder, an aggregation of such cylinders, end to end, must form a rounded filament, as in *Meloseira* (Figs. 97, 98); and whatever may be the form of the sides of the cells, if they be parallel one to the other, a *straight* filament will still be produced, as in *Achnanthes* (Fig. 93). But if, instead of being parallel, the sides be somewhat inclined towards each other, a *curved* band will be the result; this may not continue entire, but may so divide itself as to form fan-shaped expansions,

as those of *Lichmophora flabellata* (Fig. 91); or the cohesion may be sufficient to occasion the band to wind itself (as it were) round a central axis, and thus, not merely to form a complete circle, but a spiral of several turns, as in *Meridion circulare* (Fig. 92, B). Many Diatoms, again, possess a *stipes* or stalk-like appendage, by which they are attached to other plants or to stones, pieces of wood, &c., and this may be a simple foot-like appendage, as in *Achnanthes longipes* (Fig. 93), or it may be a composite plant-like structure, as in *Lichmophora* (Fig. 91), *Gomphonema* (Fig. 89), and *Mastogloia* (Fig. 99). Little is known respecting the nature of this *stipes*; it is, however, quite flexible; and may be conceived to be an extension of the cellulose coat unconsolidated by silicium, analogous to the prolongations which have been seen in the *Desmidiaceæ* (§ 163), and to the filaments which sometimes connect the cells of the *Palmellaceæ* (§ 194). Some Diatoms, again, have a mucous or gelatinous investment, which may even be so substantial that they lie as it were in a bed of it, as in *Mastogloia* (Figs. 99, 100), or which may form a sort of tubular sheath, as in *Schizonema*. In a large proportion of the group, however, the frustules are always met with entirely free; neither remaining in the least degree coherent one to another, after the process of duplicative subdivision has once been completed; nor being in any way connected, either by a *stipes*, or by a gelatinous investment. This is the case, for example, with *Triceratium* (Fig. 79), *Pleurosigma* (Fig. 80), *Actinocyclus* (Figs. 84, 101, *bb*), *Heliopecta* (Fig. 85), *Arachnoidiscus* (Fig. 86), *Campylodiscus* (Fig. 87), *Suriella* (Fig. 88), *Coscinodiscus* (Fig. 101, *a, a, a*), and many others. The discoid forms, however, when obtained in their living state, are commonly found cohering to the surface of seaweeds.

174. We have now to examine more minutely into the curious structure of the siliceous envelope, which constitutes the characteristic feature of the Diatomaceæ, and the presence of which imparts a peculiar interest to the group, not merely on account of the elaborately-marked pattern which it often exhibits, but also through the perpetuation of the minutest details of that pattern, in the specimens obtained from fossilized deposits (Figs. 101, 102). The siliceous envelope of every Diatomaceous 'frustule' or cell, consists of two *valves* or plates, usually of the most perfect symmetry, closely applied to each other, like the two valves of a Mussel or other bivalve shell, along a line of junction or *suture*; and each valve being more or less concavo-convex, a cavity is left

between the two, which is occupied by the cell-contents. The form of this cavity, however, differs very greatly; for sometimes each valve is hemispherical, so that the cavity is globular; sometimes it is a smaller segment of a sphere, resembling a watch-glass, so that the cavity is lenticular; sometimes the central portion is completely flattened, and the sides abruptly turned-up, so that the valve resembles the cover of a pill-box, in which case the cavity will be cylindrical; and these and other varieties may coexist with any modifications of the contour of the valves, which may be square, triangular (Fig. 79), heart-shaped (Fig. 87), boat-shaped (Fig. 88, A), or very much elongated (Fig. 80, A), and may be furnished (though this is rare among the Diatomaceæ) with projecting out-growths (Fig. 81). In all instances, the frustule is considered to present its 'front' view, when its suture is turned towards the eye, as in Fig. 88, B, C; whilst its 'side' view is seen, when the centre of either valve is directly beneath the eye (A). Although the two valves meet along the suture, in those newly-formed frustules which have been just produced by binary subdivision (as shown in Fig. 81, A, e), yet as soon as they begin to undergo any increase, the valves separate from one another, and the cell-membrane which is thus left exposed, immediately becomes consolidated by siliceous matter, and thus forms a sort of *hoop* that intervenes between the valves (as seen at B); this hoop becomes broader and broader with the increase of the cell in length; and it sometimes attains a very considerable width (Fig. 81, A, b). As growth and self-division are continually going-on when the frustules are in a healthy vigorous condition, it is rare to find a specimen in which the valves are not in some degree separated by the interposition of the 'hoop.'—The impermeability of the siliceous envelope renders necessary some special aperture, through which the surrounding water may communicate with the contents of the cell. Such apertures are found along the whole line of suture in disk-like frustules; but when the Diatom is of an elongated form, they are found at the extremities of the frustules only. They do not appear to be absolute perforations in the envelope, but are merely points at which its siliceous impregnation is wanting; and these are usually indicated by slight depressions of its surface. In some Diatoms, as *Surirella* (Fig. 88) and *Campylodiscus* (Fig. 87), these interruptions are connected with what seem to be minute canals hollowed-out between the siliceous envelope and the membrane investing the endochrome. In

many genera, the surface of each valve is distinguished by the presence of a longitudinal band, on which the usual markings are deficient; and this is widened into small expansions at the extremities, and sometimes at the centre also, as we see in *Pleurosigma* (Fig. 80) and *Gomphonema* (Fig. 89). This band seems to be merely a portion in which the siliceous envelope is thicker than it is elsewhere, forming a sort of rib that seems designed to give firmness to the valve; and its expansions are solid nodules of the same substance.*

175. The nature of the delicate and regular markings, with which probably every Diatomaceous valve is beset, has been of late years a subject of much discussion among Microscopists, and cannot be said to be even yet settled, although (in the Author's opinion) the weight of evidence now decidedly preponderates on one side. In the first place it may be

FIG. 73.

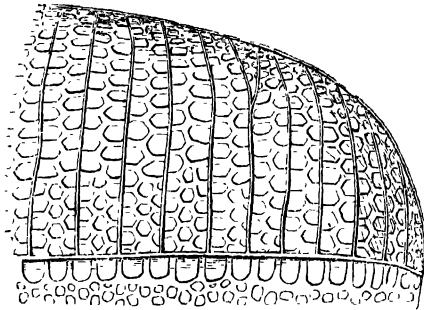
Portion of Cell of *Isthmia nervosa*, highly magnified.

remarked, that there is a much greater uniformity in the general character of these markings, than was supposed when attention was first directed to them; for what were at first supposed to be *lines*, are now resolved by objectives of large

* These *nodules* were mistaken by Prof. Ehrenberg for *apertures*; and in this error he has been followed by Kutzing. There cannot any longer, however, be a doubt as to their real nature. As Prof. W. Smith has justly remarked:—"The internal contents of the frustule never escape at these points when the frustule is subjected to pressure, but invariably at the suture or at the extremities, where the foramina already described exist. Nor does the valve, when fractured, show any disposition to break at the expansions of the central line, as would necessarily be the case were such points perforations and not nodules."

angular aperture into *rows of dots*; and these dots, when sufficiently magnified, are found to bear a close resemblance to the coarser markings on the larger species. It is to the latter, therefore, that we should have recourse for the determination of the nature of these markings; and we cannot resort to better illustrations, than those which are afforded by *Isthmia* (Fig. 78), *Triceratium* (Fig. 79), and *Biddulphia* (Fig. 81), in all of which the structure of the valve can be distinctly seen under a low magnifying power and with ordinary light. In each of these instances, we

see a number of *areolæ*, rounded, oval, or hexagonal, with intervening spaces, symmetrically disposed; and the idea at once suggests itself, that these areolæ are portions of the surface either *elevated-above* or *depressed-below* the rest. That the latter is their true condition, is suggested by the appearances they present when the light is obliquely directed; and it may also be inferred from the aspect presented by these objects when viewed by the black-ground illumination (§ 61), since the areolæ are then less bright than the intervening spaces, less light being stopped by their thinner substance. Moreover, when a valve is broken, the line of fracture corresponds to

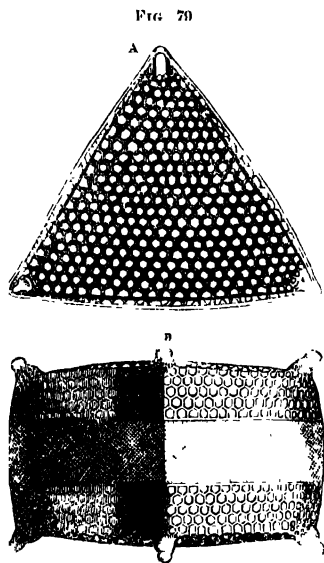

Triceratium fava:—A, side view; n, front view.

what, on this supposition, is its weakest portion; since it passes through the areolæ, instead of through the intervening spaces, which last would be the weaker portions if the areolæ were prominences. But the most satisfactory proof, that the areolæ are depressions, is perhaps that which is afforded by a

side-view of them, such as may be obtained by examining the curved edges of the valves in *Isthmia*; this, it may be safely affirmed, can leave no doubt in the mind of any competent and unprejudiced observer, as to the nature of the markings in *that* genus; and analogy would seem to justify the extension of the same view to the other cases in which the microscopic appearances correspond.* Now it would not be difficult to bring-together a connected series of Diatomaceæ, in which the markings, still exhibiting the same general aspect, become more and more minute, requiring for their resolution the use of oblique light or of stops with a central diaphragm, and of objectives of larger and larger angular aperture; until we come to those species which present the greatest difficulty, and the nature of whose markings seems most obscure. The more perfectly these markings can be defined, however, in any case, the more decidedly are they found to correspond with what has been already seen. Thus, if we examine *Pleurosigma angulatum*, one of the easier tests (§ 102), with an objective of 1-4th inch focus and 75° aperture, we shall see very much what is represented in Fig. 80, A; namely, a double series of somewhat interrupted lines, crossing each other at an angle of 60 degrees, so as to have between them imperfectly-defined lozenge-shaped spaces.† When, however, the valve is examined with an objective of 1-12th inch focus, having an angular aperture of 130°, and is illuminated by oblique rays, its hexagonal areolation becomes very distinct, as shown at B. And if a photographic representation obtained by such a power be itself enlarged by photography, as has been accomplished by Mr. Wenham, the appearance represented at C is obtained; which is in all respects comparable with that presented under a low power by the valve of *Triceratium* or *Isthmia*. At the upper part of this figure, which represents a portion of the object that was accurately in focus,

* It is considered by Prof. W. Smith, that this areolation is indicative of a *cellular* structure in the siliceous envelope. But when it is borne in mind that the entire frustule constitutes a single cell, such a hypothesis seems altogether inadmissible. The Author would rather consider the markings in question as analogous to those which are presented by the surface of many pollen-grains (Fig. 189), of whose single-celled nature no doubt can exist; and in his researches on the Foraminifera, he has met with several instances, in which the calcareous investments of those segments of sarcodæ which must be considered as the representatives of single cells, are marked with a like areolation, the areolæ being here unquestionably depressions, formed by the thinning-away of the envelope at those parts.

† This representation is taken from a Photograph by Mr. Delves, which is imitated as closely as Wood-engraving can imitate on a scale of such minuteness, but with a reversal of the lights and shades.

the hexagonal areae are seen to be light, and the intervening spaces dark; the reverse is the case with the lower portion, which was out of focus; and a curious transition from one condition to the other is seen in the intermediate part.*

FIG. 80.

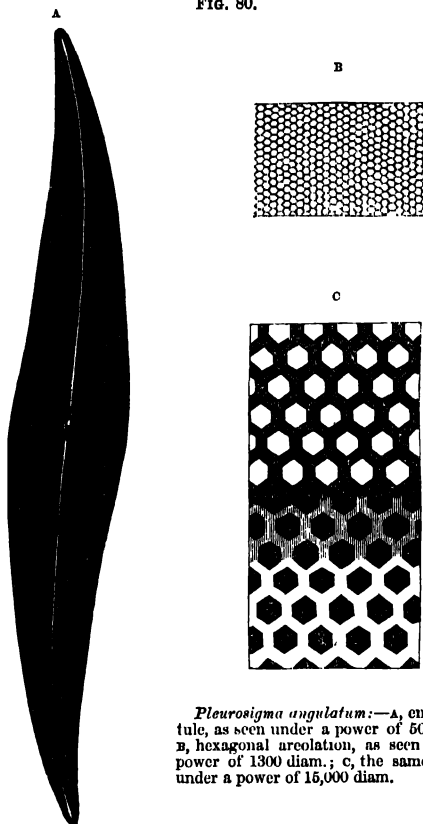

Pleurosigma angulatum:—A, entire frustule, as seen under a power of 500 diam.; B, hexagonal areolation, as seen under a power of 1300 diam.; c, the same, as seen under a power of 15,000 diam.

* The Author does not think it necessary to go more in full into the discussion of the nature of these markings, which some have represented to be due to hemispherical elevations on the valves; as he thinks that no argument

176. The process of multiplication by self-division takes place among the Diatomaceæ on the same general plan as in the Desmidiaceæ, but with some modifications incident to the peculiarities of the structure of the former group.—The first stage consists in the elongation of the cell, and the increase in the breadth of the ‘hoop,’ which is well seen in Fig. 81; for

FIG. 81.

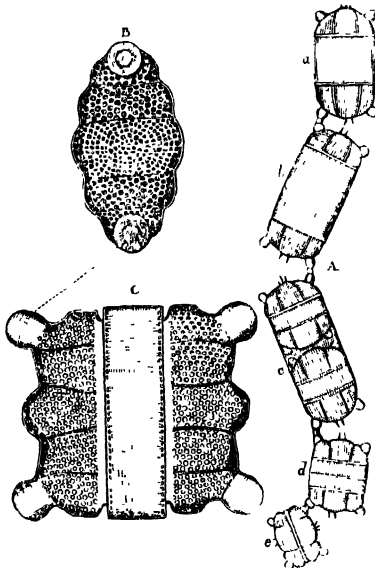

Biddulphia pulchella:—A, chain of cells in different states; a, full size; b, elongating preparatory to subdivision; c, formation of two new cells; d, e, young cells;—B, end-view;—C, side-view of a cell more highly magnified.

in the newly-formed cell *e*, the two valves are in immediate apposition, in *d* a hoop intervenes, in *a* this hoop has become

is likely to convince those, whose minds are prepossessed with a conception which influences their interpretation of what they see. To those who come fresh to the question, he would strongly recommend the *education of their judgment* upon the larger and more coarsely-marked Diatoms, as above described, before they commit themselves to an opinion on either side.—A fuller statement of the question will be found in the “Micrographic Dictionary,” ‘Introduction,’ p. xxxiii., and *Arts.* ‘Angular Aperture’ and ‘Diatomaceæ.’

much wider, and in *b* the increase has gone on until the original form of the cell is completely changed. At the same time, the endochrome separates into two halves, so that its granules form two layers, applied to the opposite sides of the frustule; the nucleus also subdivides, in the manner formerly shown (Fig. 67, G, H, I); and (although the process has not been clearly made-out in this group) it may be pretty certainly concluded that the primordial utricle folds-in, first forming a mere constriction, then an hour-glass contraction, and finally a complete double partition, as in other instances (§ 165). From each of these two surfaces a new siliceous valve is formed, as shown at Fig. 81, A, C, just as a new cellulose-wall is generated in the subdivision of other cells; and this valve is usually the exact counterpart of the one to which it is opposed, and forms with it a complete cell, so that the original frustule is replaced by two frustules. Sometimes, however, the new valves seem to be a little larger than their predecessors; so that, in the filamentous species, there may be an increase sufficient to occasion a gradual widening of the filament, although not perceptible when two contiguous frustules are compared; whilst, in the free forms, frustules of different sizes may be met-with, of which the larger are more numerous than the smaller, the increase in number having taken-place in geometrical progression, whilst that of size was uniform. It is not always clear what becomes of the 'hoop.' In *Biddulphia* and *Isthmia* (Fig. 96) the two young cells slip out of it, and the hoop at last becomes completely detached; and the same thing happens with many other Diatoms; so that the 'hoops' are to be found in large numbers, in the settlements of water in which they have been growing for some time. In *Meloseira* (Figs. 97, 98), and perhaps in the filamentous species generally, on the other hand, the 'hoops' appear to keep the new frustules united together for some time. But in some other cases, all trace of it is lost; and it may be questioned whether it has ever been properly silicified, and whether it does not become fused (as it were) into the gelatinous envelope.—During the healthy life of the Diatom, the process of self-division is continually being repeated; and a very rapid multiplication of frustules thus takes place, all of which (as in the cases already cited, §§ 150, 165) must be considered to be repetitions of one and the same individual. Hence it may happen (as among the Desmidiaceæ, § 168) that myriads of frustules may be found in one locality, uniformly distinguished by some peculiarity of form, size, or marking; which may yet have

had the same remote origin as another collection of frustules, found in some different locality, and alike distinguished by some peculiarity of its own. For there is strong reason to believe, that such differences spring-up among the progeny of any true *generative* act (§ 178); and, when that progeny is dispersed by currents into different localities, each will continue to multiply its own special type, so long as the process of self-division goes on.

177. It is uncertain whether the Diatomaceæ also multiply by the breaking-up of their endochrome into 'gonidia,' and by the liberation of these, either in the *active* condition of 'zoospores,' or in the state of 'still' or 'resting' spores. Certain recent observations by Focke,* however, taken in connection with the analogy of other Protophytes, and with the fact that the sporangial frustules undoubtedly thus multiply by gonidia (§ 178), seem to justify the conclusion that such a method of multiplication does obtain in this group. And it is not at all improbable, that very considerable differences in the size, form, and markings of the frustules, such as many consider sufficient to establish a diversity of species, have their origin in this mode of propagation. It is probable that, so long as the vegetating processes are in full activity, multiplication takes-place in preference by self-division; and that it is when deficiency of warmth, of moisture, or of some other condition, gives a check to these, that the formation of encysted gonidia, having a greater power of resisting unfavourable influences, will take-place; whereby the species is maintained in a dormant state, until the external conditions are favourable to a renewal of active vegetation (§ 156).

178. The process of 'conjugation,' or true Generation, has been observed to take-place among the ordinary Diatomaceæ, almost exactly as among the Desmidiaceæ. Thus in *Surirella* (Fig. 88), the valves of two free and adjacent frustules separate from each other at the sutures, and the two endochromes (probably included in their primordial utricle) are discharged; these coalesce, and form a single sporangial mass, which becomes inclosed in a gelatinous envelope; and in due time this mass shapes itself into a frustule resembling that of its parent, but of larger size. In *Epithemia* (Fig. 82, A, B), however,—the first Diatom in which the conjugating process was observed, by Mr. Thwaites,—the endochrome of each of the conjugating frustules (C, D) appears to divide at the time of its discharge,

* "Physiologisch. Studien," Heft ii. 1863; quoted in "Micrographical Dictionary," p. 201.

into two halves; each half coalesces with half of the other endochrome; and thus two sporangial frustules (E, F) are

FIG. 82.

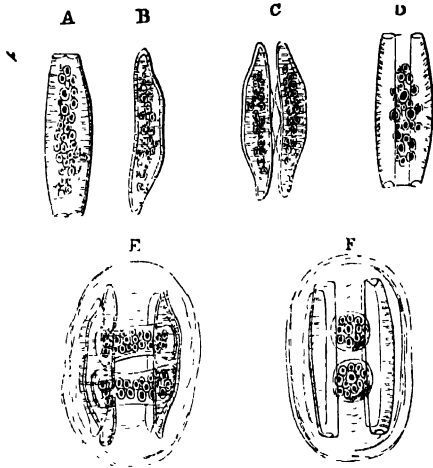

Conjugation of *Epithemia turgida*:—A, front view of single frustule; B, side view of the same; C, two frustules with their concave surfaces in close apposition; D, front view of one of the frustules, showing the separation of its valves along the suture; E, F, side and front views after the formation of the sporangia.

formed (as in *Closterium lineatum*, § 169, note), which, as in the preceding case, become invested with a gelatinous envelope, and gradually assume the form and markings of the parent-frustules, but grow to a very much larger size, the sporangial masses having obviously a power of self-increase up to the time when their envelopes are consolidated. This *double* conjugation seems to be the ordinary type of the process among the Diatoms. A curious departure from the usual plan is observed in some of the filamentous species; for their component cells, instead of conjugating with those of another filament (as is the case with the filamentous *Desmidiaceæ*, § 170, and usually but not invariably with the *Zygnemaceæ*, § 199), conjugate with each other; and this may take

place even before they have been completely separated by self-division. Thus in *Meloseira* (§ 188) and its allies, the endochrome of particular frustules, after separating as if for the formation of a pair of new cells, moves-back from the extremities towards the centre, rapidly increasing in quantity and aggregating into a sporangial mass (Fig. 83, 2, *a, b, c*), and

FIG. 83.

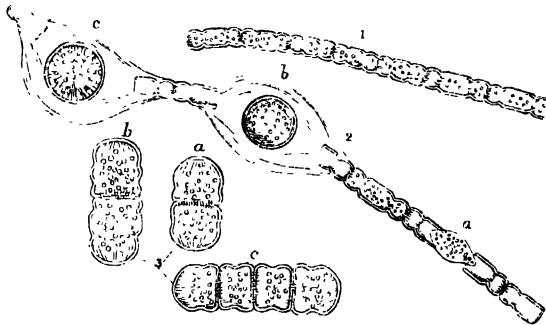

Self-Conjugation of *Aulacoseira crenulata*.—1, simple filament; 2, filament developing sporangia; *a, b, c*, successive stages in the formation of sporangia; 3, embryonic frustules, in successive stages, *a, b, c*, of multiplication.

around this a new envelope is developed, which may or may not resemble that of the ordinary frustules, but which remains in continuity with them, giving rise to a strange inequality in the size of the different parts of the filaments (Figs. 97, 98).—Of the subsequent history of the sporangial frustule, much remains to be learned; and it is probably not the same in all cases. It has been already shown that the sporangial frustule, even where it precisely resembles its parent in form and marking, greatly exceeds it in size; and this excess seems to render it improbable that it should reproduce the race by ordinary self-division. Appearances have been seen, which make it probable that the contents of each sporangial frustule break-up into 'gonidia;' and that it is from these that the new generation originates. These gonidia, if each be surrounded (as in many other cases) by a distinct cyst, may remain undeveloped for a considerable period; and they must augment considerably in size, before they attain the dimensions of the parent frustule.

It is in this stage of the process, that the modifying influence of external agencies is most likely to exert its effects; and it may be easily conceived that (as in higher Plants and Animals) this influence may give rise to various diversities among the respective individuals of the same brood; which diversities (as we have seen) are transmitted to all the repetitions of each, that are produced by the self-dividing process. Hence a very considerable latitude is to be allowed to the limits of species, when the different forms of Diatomaceæ are compared; and here, as in many other cases, a most important question arises as to what *are* those limits,—a question which can only be answered by such a careful study of the entire life-history of every single type, as may advantageously occupy the attention of many a Microscopist, who is at present devoting himself to the mere detection of differences, and to the multiplication of reputed species.*

179. Most of the Diatoms which are not fixed by a stipes, possess some power of spontaneous movement; and this is especially seen in those, whose frustules are of a long narrow form, such as that of the *Navicula* generally. The motion is of a peculiar kind, being usually a series of jerks, which carry forward the frustule in the direction of its length, and then carry it back through nearly the same path. Sometimes, however, the motion is smooth and equable; and this is especially the case with the curious *Bacillaria paradoxa* (Fig. 92, B), whose frustules slide over each other in one direction, until they are all-but detached, and then slide as far in the opposite direction, repeating this alternate movement at very regular intervals.† In either case, the motion is obviously quite of a different nature from that of beings possessed of a power of self-direction. "An obstacle in the path," says Prof. W. Smith, "is not avoided, but pushed-aside; or, if it be sufficient to avert the onward course of the frustule, the latter is detained for a time equal to that which it would have occupied in its forward progression, and then retires from the impediment as if it had accomplished its full course." The character of the movement is obviously similar to that of those motile forms of Protophyta which have been

* See on this subject a valuable Paper by Prof. W. Smith 'On the Determination of Species in the *Diatomaceæ*,' in the "Quart. Journ. of Microsc. Science," vol. iii. p. 130: a Memoir by Prof. W. Gregory 'On shape of Outline as a specific character of *Diatomaceæ*,' in "Trans. of Microsc. Soc.," 2nd Series, vol. iii.; and the Author's Presidential Address in the same volume, pp. 44-60.

† This curious phenomenon, the Author has himself more than once had the opportunity of witnessing.

already described ; but it has not yet been definitely traced to any organ of impulsion ; and the cause of it is still obscure.* By Prof. W. Smith it is referred to forces operating within the frustule, and originating in the vital operations of growth, &c., which may cause the surrounding fluid to be drawn-in through one set of apertures, and expelled through the other.† “If,” as he remarks, “the motion be produced by the exosmose taking-place alternately at one and the other extremity, while endosmose is proceeding at the other, an alternating movement would be the result in frustules of a linear form ; whilst in others of an elliptical or orbicular outline, in which foramina exist along the entire line of suture, the movements, if any, must be irregular or slowly lateral. Such is precisely the case. The backward and forward movements of the *Naviculæ* have been already described ; in *Surirella* (Fig. 88) and *Campylodiscus* (Fig. 87), the motion never proceeds further than a languid roll from one side to the other ; and in *Gomphonema* (Fig. 89), in which a foramen, fulfilling the nutritive office, is found at the larger extremity only, the movement (which is only seen when the frustule is separated from its stipes) is a hardly perceptible advance in intermitted jerks in the direction of the narrow end.”

180. The principles upon which this interesting group should be classified, cannot be properly determined, until the history of the Generative process,—of which nothing whatever is yet known in a large proportion of Diatoms, and very little

* Prof. Smith says:—“Among the hundreds of species which I have examined in every stage of growth and phase of movement, aided by glasses which have never been surpassed for clearness and definition, I have never been able to detect any semblance of a motile organ; nor have I, by colouring the fluid with carmine or indigo, been able to detect in the coloured particles surrounding the Diatom, those rotatory movements, which indicate, in the various species of true Infusorial animalcules, the presence of cilia.” (Synopsis of British Diatomaceæ, Introduction, p. xxiv.)—Mr. Jabez Hogg, however, has recently stated (“Quart. Journ. of Microsc. Science,” vol. iii. p. 235) that, by the employment of the same mode of illumination as that by which the ciliary action may be discerned in *Closterium*, &c. (§ 164), a ciliary movement may be detected at the orifices which have already been described as existing in the siliceous envelope of the Diatomaceous frustule (§ 174). It may be questioned, however, whether this be anything else than an optical illusion, arising from the existence of *currents* at these orifices, produced by the vital actions going-on within the cell, as noticed above.

† It has been objected to this view, by the authors of the “Micrographic Dictionary,” that, if such were the case, the like movements would be frequently met-with in other minute unicellular organisms. They seem to have forgotten, however, that there are no other such organisms, in which the cell is almost entirely enclosed in an impermeable envelope, which limits the imbibition and expulsion of fluid to a small number of definite points, instead of allowing it to take place equally (as in other unicellular organisms) over the entire surface.

in any of them,—shall have been thoroughly followed-out. As already stated, there is a strong probability that many of the forms which are at present considered as distinct from each other, would prove to be but different states of the same, if their *whole* history were ascertained. On the other hand, it is by no means impossible that some which appear to be nearly related in the structure of their frustules and in their mode of growth, may prove to have quite different modes of reproduction. At present, therefore, *any* classification must be merely provisional; and in the notice now to be taken of some of the most interesting forms of the *Diatomaceæ*, the method of Prof. W. Smith, which is based upon the degree of connection that remains between the several frustules after self-division, will be adopted, since it possesses the advantage of being in accordance with the general ‘physiognomics’ of these organisms, as it brings-together those forms which correspond most closely in plan of growth; but it cannot be regarded as a truly natural classification, since it often separates genera which are closely allied in the structure of the individual frustules, as, for example, *Coscinodiscus* and *Meloseira*.—The whole Order is thus grouped, in the first instance, under two Tribes; the *first* including those which have the frustules naked, that is, neither imbedded in gelatine, nor enclosed in a membranaceous tube; whilst the *second* is composed of those forms, whose frustules have a gelatinous or membranaceous envelope. The frustules of the Diatoms belonging to the first tribe, however, may have various degrees of connection; for whilst, in some, (*a*) the union is dissolved almost immediately upon the completion of self-division, there are others (*b*) in which a gelatinous cushion or a stipes, to which the frustules are attached by a small portion of their surface, maintains a partial connection between the divided frustules, and others (*c*), again, in which the frustules remain in more or less complete cohesion, and form filaments, which, if the cohesion be limited to the angles of the frustules, are mere zig-zag chains, but, if the cohesion extend to the entire surfaces of their sides, are continuous filaments, either flattened or cylindrical.

181. That section of the first tribe, in which the frustules are entirely disconnected from each other after the completion of their self-division, includes a number of beautiful discoidal forms, which seem to constitute a natural group, and may therefore be appropriately noticed in connection with each other. The genus *Coscinodiscus* is one of great interest, from the vast abundance of its valves in certain fossil deposits

(Fig. 101, *aaa*), especially the Infusorial earth of Richmond in Virginia, of Bermuda, and of Oran, as also in Guano. Each frustule is of discoidal shape, being composed of two nearly flattened valves, united by a hoop; so that, if the frustules remained in adhesion, they would form a filament resembling that of *Melosira* (Fig. 97). The regularity of the hexagonal divisions on the valves, renders them beautiful microscopic objects; in some species, the areolæ are smallest near the centre, and gradually increase in size towards the margin; in others, a few of the central areolæ are the largest, and the rest are of nearly uniform size. Most of the species are either marine, or are inhabitants of brackish water; when living, they are most commonly found adherent to sea-weeds or zoophytes; but when dead, the valves fall as a sediment to the bottom of the water. In both these conditions, they were found by Prof. J. Quekett in connection with Zoophytes which had been brought home from Melville island by Sir E. Parry; and the species seemed to be identical with those of the Richmond earth.—Nearly allied to the preceding is the beautiful genus *Actinocyclus* (Fig. 84), of which also the frustules are discoidal in form, but of which each valve, instead of being flat, has an undulating surface, as is seen in front view (B); giving to the side view (A) the appearance of being marked by radiating bands. Owing to this peculiarity of shape, the whole surface cannot be brought into focus at once, except with a low power; and the difference of aspect which the different radial divisions present in Fig. 84, is simply due to the fact, that one set is out of focus, whilst the other is in it, since the appearances are reversed by merely altering the focal adjustment. The number of radial divisions has been considered a character of sufficient importance to serve for the distinction of species; but this is probably subject to variation; since we not unfrequently meet with disks, of which one has (say) 8 and another 10 such divisions,

FIG. 84.

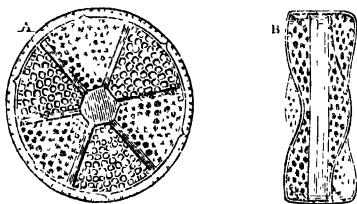

Actinocyclus undulatus:—A, side view;
B, front view.

not be brought into focus at once, except with a low power; and the difference of aspect which the different radial divisions present in Fig. 84, is simply due to the fact, that one set is out of focus, whilst the other is in it, since the appearances are reversed by merely altering the focal adjustment. The number of radial divisions has been considered a character of sufficient importance to serve for the distinction of species; but this is probably subject to variation; since we not unfrequently meet with disks, of which one has (say) 8 and another 10 such divisions,

but which are so precisely alike in every other particular, that they can scarcely be accounted as specifically different. The valves of this genus are very abundant in the infusorial earths of Richmond, Bermuda, and Oran (Fig. 101, *b, b, b*); and many of the same species have been found recent in guano, and in the seas of various parts of the world. The frustules in their living state appear to be generally attached to seaweeds or zoophytes.

182. The Bermuda earth also contains the very beautiful form (Fig. 85), which, though scarcely separable from

FIG. 85.

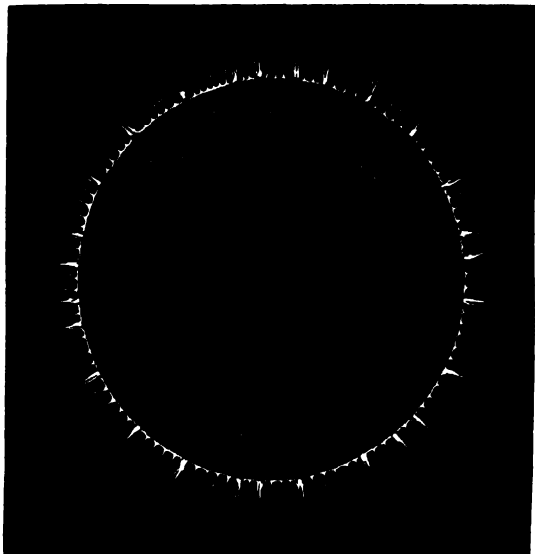
*Heliopecta.*

Actinocyclus except by its marginal spines, has received from Prof. Ehrenberg the distinctive appellation of *Heliopecta* (sun-shield). In the representation here given, the object is delineated as seen by the parabolic illuminator (§ 61), which brings into view certain features that can scarcely be seen by

ordinary transmitted light. Four of the radial divisions are seen to be marked-out into circular areolæ; but in the four which alternate with them, a minute granular structure is observable. This may be shown by careful adjustment of the focus, to exist over the whole of the valve, even on the divisions in which the circular areolation is here displayed; and it hence appears that this marking is *superficial*, and that the circular areolation exists in a deeper layer of the siliceous lorica. In the alternating divisions whose surface is here displayed, the subjacent areolation, when brought into view by focussing down to it, is seen to be formed of equilateral triangles; it is not, however, nearly so well marked as the circular areolation of the first-mentioned divisions. The dark spots seen at the ends of the rays, like the dark centre, appear to be solid tubercles of siliceous matter, not traversed by markings, as in many other Diatoms; most assuredly they are *not* orifices, as supposed by Prof. Ehrenberg. Of this type, again, specimens are found presenting 6, 8, or 10 radial divisions, but in other respects exactly similar; on the other hand, two specimens agreeing in their number of divisions, may exhibit minute differences of other kinds; in fact, it is rare to find two that are *precisely* alike. It seems probable, then, that we must allow a considerable latitude of variation in these forms, before attempting to separate any of them as distinct species.—Another very beautiful discoidal Diatom, which occurs in guano, and is also found attached to sea-weeds from different parts of the world (especially to a species employed by the Japanese in making soup), is the *Arachnoidiscus* (Fig 86), so named from the resemblance which the beautiful markings on its disk cause it to bear to a spider's web. According to Mr. Shadbolt,* who has carefully examined its structure, each valve consists of two layers; the outer one, a thin flexible horny membrane, indestructible by boiling nitric acid; the inner one, siliceous. It is the former which has upon it the peculiar spider's-web-like markings; whilst it is the latter that forms the supporting framework, which bears a very strong resemblance to that of a circular Gothic window. The two can occasionally be separated entire, by first boiling the disks for a considerable time in nitric acid, and then carefully washing them in distilled water. Even without such separation, however, the distinctness of the two layers can be made-out by focussing for each separately under a 1-4th or 1-5th in. objec-

* "Transactions of Microscopical Society," 1st Series, vol. iii, p. 49.

tive; or by looking at a valve as an opaque object (either by the Parabolic illuminator, or by the Lieberkühn, or by a side

Fig. 6

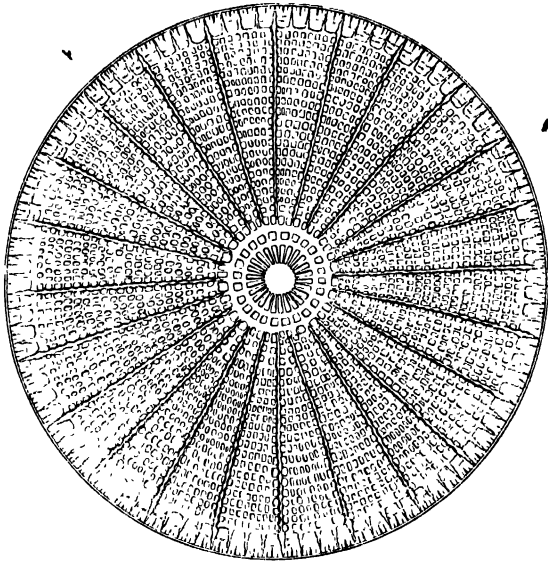

Arachnoidiscus Ehrenbergii.

light) with a 4-10ths in. objective, first from one side, and then from the other.

183. Nearly allied to the preceding in general characters, but differing in the triangular shape of its valves, is the *Triceratium*; of which striking form a considerable number of species are met-with in the Bermuda and other Infusorial carths, while others are inhabitants of the existing ocean and of tidal rivers. The *T. favus* (Fig. 79), which is one of the largest and most regularly-marked of any of these, occurs in the mud of the Thames and in various other estuaries on our own coast; it has been found, also, on the surface of large sea-shells from various parts of the world, such as those

of *Hippopus* and *Haliotis*, before they have been cleaned; and it presents itself likewise in the infusorial earth of Petersburg (U.S.). Although the *triangular* form, when the frustule is looked-at sideways, is that which is characteristic of the genus, yet in some of the species there seems a tendency to produce *quadrangular* and even *pentagonal* forms; these being marked as *varieties*, by their exact correspondence in sculpture, colour, &c., with the normal triangular forms.* This departure is extremely remarkable, since it breaks-down what seems at first to be the most distinctive character of the genus; and its occurrence is an indication of the degree of latitude which we ought to allow in other cases.—The genus *Campylodiscus* (Fig. 87) is distinguished by its saddle-shaped curvature, and

FIG. 87.

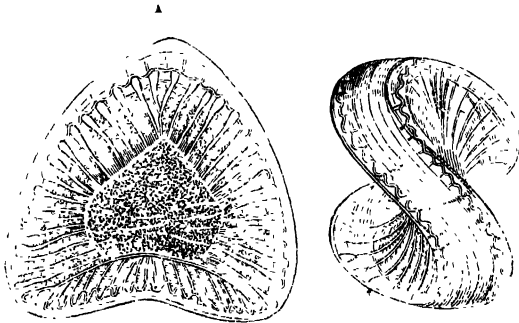

Campylodiscus costatus:—A, front view; B, side view.

by its ribbed markings, which seem to indicate the presence of canals excavated in or beneath the valves, for the passage of fluid between the orifices in the siliceous envelope and the soft cell-membrane beneath. The form of the valves, in most of the species, is circular, or nearly so; some are nearly flat, whilst in others the twist is greater than in the species here represented. Some of the species are marine, whilst others occur in fresh water; a very beautiful form, the *C. clypeus*, exists in such abundance in the Infusorial stratum discovered by Prof. Ehrenberg at Soos near Ezer in Bohemia, that the earth seems

* See Mr Brightwell's excellent memoir 'On the genus *Triceratium*,' in "Quart. Microsc. Journ.," vol. i. p. 245. ●

almost entirely composed of it.—Some of the forms of the last genus lead towards *Surirella* (Fig. 88), which, like it, presents

FIG. 88.

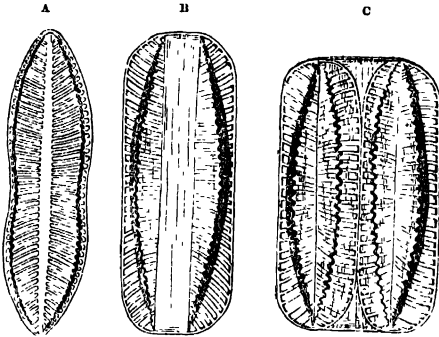

Surirella constricta;—A, side view; B, front view, C, binary subdivision.

the appearance of possessing a canalicular system, though this is by no means equally conspicuous in all the species. The distinctive character of the genus, in addition to the presence of the canaliculi, is derived from the longitudinal line down the centre of each valve (A), and the prolongation of the margins into 'alæ.' Numerous species are known, which are mostly of a somewhat ovate form, some being broader and others narrower than *S. constricta*; the greater part of them are inhabitants of fresh or brackish water, though some few are marine; and several occur in those infusorial earths, which seem to have been deposited at the bottoms of lakes, such as that of the Mourne mountains in Ireland (Fig. 102, b, c, k).

184. We now come to that interesting series of forms, which has been ranked under the genus *Navicula*, until its recent subdivision by Prof. W. Smith into the three genera *Navicula*, *Pinnularia*, and *Pleurosigma*, each of which still comprehends a very large number of species. They are all distinguished by the oblong or lanceolate form of their valves, by the convexity of their surfaces, by the presence of a longitudinal line along the middle line of each valve, dilating into nodules at the centre and extremities, and by the more or less conspicuous marking of the valves with transverse or oblique striæ, which, under a sufficient magnifying power, are resolvable

into a regular areolation, resembling, though on a very minute scale, that of the more coarsely-marked Diatoms (§ 175). The genus *Navicula*, as now constituted, is distinguished by these striæ, and by the appearance of rows of circular dots which they present, when sufficiently magnified. In *Pinnularia* (Fig. 102, *h*), the striæ are not resolvable into dots, and are so strongly marked as almost to resemble the 'ribs' of *Surirella*. The genus *Pleurosigma* is at once distinguished by the peculiar curvature of its valves (Fig. 80); and it is further remarkable for the extreme closeness of their striation, and for the consequent 'difficulty' which attends its resolution into a regular areolation.—The species of the first two of these genera are for the most part inhabitants of fresh water; and they constitute a large part of most of the Infusorial Earths which were deposited at the bottoms of lakes. Among the most remarkable of such deposits, are the substances largely used in the arts for the polishing of metals, under the names of Tripoli and rotten-stone; these consist in great part of the frustules of *Naviculæ* and *Pinnulariæ*. The Polierschiefer or polishing-slate of Bilin in Bohemia, the powder of which is largely used in Germany for the same purpose, and which also furnishes the fine sand used for the most delicate castings in iron, occurs in a series of beds averaging fourteen feet in thickness; and these present appearances which indicate that they have been at some time exposed to a high temperature. The well-known Turkey-stone, so generally employed for the sharpening of edge-tools, seems to be essentially composed of a similar aggregation of frustules of *Navicula*, &c., which has been consolidated by heat. The species of *Pleurosigma*, on the other hand, are for the most part either marine, or are inhabitants of brackish water; and they comparatively seldom present themselves in a fossilized state.—The genus *Stauroneis*, which belongs to the same group, differs from all the preceding forms, in having the central nodule of each valve dilated laterally into a band free from striæ, which forms a cross with the longitudinal band; of this very beautiful form, some species are fresh-water; others marine; and the former present themselves frequently in certain infusorial earths.*

185. The group we have next to notice, consists of those genera which have the frustules, after self-division, attached by a gelatinous cushion, or by a dichotomous stipes, (Fig. 89).

* For some very curious examples of the extent to which variation in form, size, and distance of striæ, may take-place in this group, among individuals which must be accounted as of the same species, see the memoirs of Profrs. W. Smith and W. Gregory already referred-to (p. 313, note).

Many of these present a strong resemblance to some of the preceding, so far as the structure of their frustules is itself

FIG. 89.

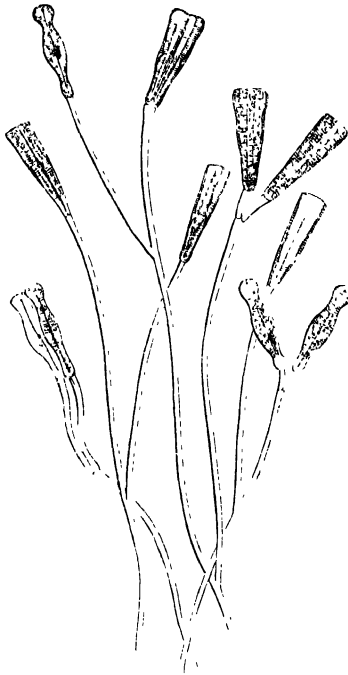

Gomphonema gemmatum: its frustules connected by stipes

concerned; so that when, as frequently happens, they are found unattached, the difference is not apparent. In *Synedra* (Fig. 102, *l*), which is not unlike a long narrow *Navicula* (an imperfect longitudinal line, with central and terminal dilations, being often, but not always, apparent), the frustules are at first invariably attached to larger *Algæ*, or other aquatic plants, by a cushion-like gelatinous basis; and when they remain adherent to this after repeated subdivision, they sometimes form a fan-like band of frustules, not unlike that of

Lichmophora (Fig. 91), or even a stellate cluster, the appearance of which is extremely characteristic. So again, the frustules of *Gomphonema* (Fig. 90) in a side view, are not

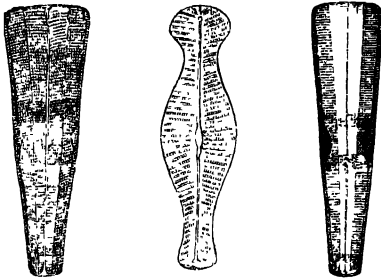

Gomphonema geniculatum.—A, side view of frustule more highly magnified; B, front view; C, frustule in the act of self-division.

unlike those of *Navicula*; but they are distinguished in front view by their cuncate (wedge-like) form, which arises chiefly from the unequal development of the membrane connecting the valves, at the upper and lower ends. The stipes seems to be formed by an exudation from the frustule, which is secreted only during the process of self-division; hence when this process has been completed, the extension of the single filament below the frustule ceases; but when it recommences, a sort of joint or articulation is formed, from which a new filament begins to sprout for each of the half-frustules; and when these separate, they carry-apart the peduncles which support them, as far as their divergence can take place; and it is in this manner that the dichotomous character is given to the entire stipes (Fig. 89). The species of *Gomphonema* are, with scarcely an exception, inhabitants of fresh-water; and are among the commonest forms of *Diatomaceæ*.—In *Lichmophora* (Fig. 91) we meet with a different mode of growth; for the newly-formed part of the stipes, instead of itself becoming double with each act of self-division of the frustule, increases in breadth, while the frustules themselves remain coherent; so that a beautiful fan-like arrangement is produced. A splitting-away of a few frustules seems occasionally to take-place, from one side or the other, before the elongation of the stipes; so that the entire plant presents us with a more or less complete *flabella* or fan upon the summit of the branches, with

imperfect flabellæ or single frustules irregularly scattered throughout the entire length of the footstalk. This beautiful plant is marine, and is parasitic upon sea-weeds and zoophytes.

186. In the group at which we now arrive, there is more or less of permanent connection between the frustules themselves; and this may depend merely upon the cohesion of

FIG. 91.

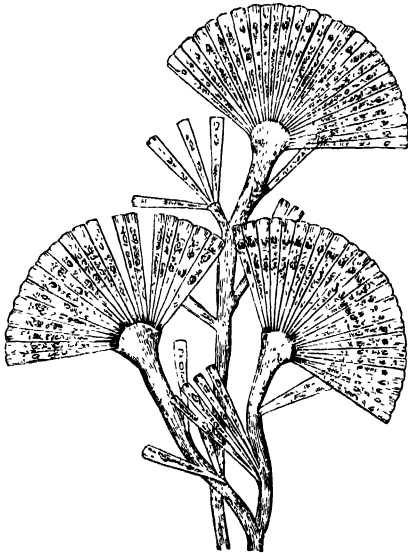
*Licmophora flabellata.*

their surfaces, or may be occasioned by the persistence of the connecting membrane of the valves, after the completion of the self-division of the frustules. To the former division belong several genera, the form of whose frustules is more or less elongated, so that the filament formed by their cohesion is a flattened band. If the two extremities of the frustule be of equal breadth, as in *Bacillaria*, the band will be straight; but if one be broader than the other, so that the frustule in front view has a cuneate or wedge-like form, the filament will be curved, as in the beautiful *Meridion circulare* (Fig. 92, A).

Although these, when gathered and placed under the microscope, present the appearance of circles overlying one another, they really grow in a helical (screw-like) form, making several continuous turns. This Diatom abounds in many localities in this country; but there is none in which it presents itself in

FIG. 92.

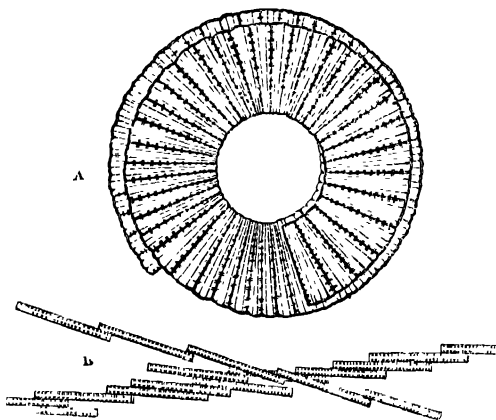
A, *Meridion circulare* — B, *Bacillaria paradoxa*.

such rich luxuriance, as in the mountain-brooks about West Point in the United States, the bottoms of which, according to Prof. Bailey, "are literally covered in the first warm days of spring with a ferruginous-coloured mucous matter, about a quarter of an inch thick, which, on examination by the microscope, proves to be filled with millions and millions of these exquisitely-beautiful siliceous bodies. Every submerged stone, twig, and spear of grass is enveloped by them; and the waving plume-like appearance of a filamentous body covered in this way is often very elegant."—The genus *Bacillaria*, so named from the staff-like form of its frustules, is now limited to the species *B. paradoxa* (Fig. 92, B), whose remarkable movements have been already described (§ 179). Owing to this displacement of the frustules, its filaments seldom present themselves with straight parallel sides, but nearly always in forms more or less oblique, such as those represented above. This curious object is an inhabitant of salt or of brackish water. Many

of the species formerly ranked under this genus are now referred to the genus *Diatoma* (§ 187); to which also the genus *Fragillaria* is nearly allied, the difference between them lying chiefly in the mode of adhesion of the frustules. These, in *Fragillaria* form long straight filaments with parallel sides; the filaments, however, as the name of the genus implies, very readily break-up into their component frustules, often separating at the slightest touch. Its various species are very common in pools and ditches.— Among the numerous genera belonging to this group, we may stop to notice *Achnanthes*; some of the species of which, particularly *A. longipes* (Fig. 93), are furnished with a single nearly-straight stipes, attached to one end of the lower margin of the first frustule of the filament. There is a curious difference in the markings of the valves of the upper and lower frustules; for while both are traversed by striae, which are resolvable under a sufficient power into rows of dots, as well as by a longitudinal line, which sometimes has a nodule at each end (as in *Navicula*), the lower valve (*a*) has also a transverse line, forming a *stauros* or cross, which is wanting in the upper valve (*c*). A persistence of the connecting membrane may sometimes be observed in this genus, so as to form an additional connection between the cells; thus, in Fig 93, it not only holds-together the two new frustules resulting from the subdivision of the lowest cell, *a*, which are not yet completely separated the one from the other, but it may be observed to invest the two frustules *b* and *c*, which have not merely separated, but are themselves beginning to undergo binary subdivi-

FIG. 93.



Achnanthes longipes:—*a*, *b*, *c*, *d*, *e*, successive frustules in different stages of self-division.

vision; and it may also be observed to invest the frustule *d*, from which the frustule *e*, being the terminal one, has more completely freed itself.

187. It is by the persistence of the connecting membrane, notwithstanding the dissolution of the adhesion between the surfaces of the valves, that the frustules are so held-together after self-division as to form zig-zag chains, in the next group; of which the genus *Diatoma* (Fig. 94), that gives the name ('cutting-through') to the whole order, is a typical example.

FIG. 94.

FIG. 95.

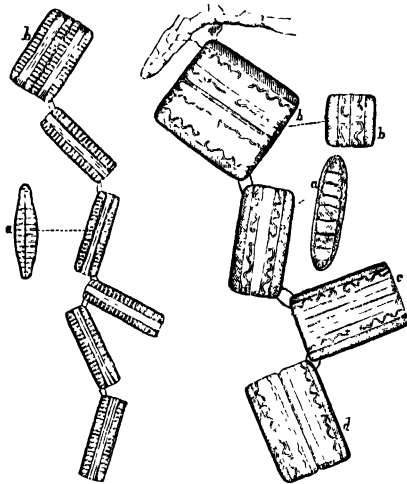

Fig. 94. *Diatoma vulgare*: side view of frustule; *b*, frustule undergoing self-division

Fig. 95.—*Grammatophora serpentina*:—*a*, front and side views of single frustule; *b, b*, front and end views of divided frustule; *c*, a frustule about to undergo self-division; *d*, a frustule completely divided.

Its valves, when turned side-ways, are seen to be strongly marked by transverse striæ, which extend into the front view. The proportion between the length and the breadth of each

valve is found to vary so considerably, that, if the extreme forms only were compared, there would seem adequate ground for regarding them as belonging to different species. This genus inhabits fresh water, preferring gently-running streams, in which it is sometimes very abundant. The genus *Grammatophora* (Fig. 95) is nearly allied to the preceding; but its transverse striæ are extremely faint and difficult of detection, so that its valves serve as 'test-objects' (§ 102, III); and the frustules, when seen in front view, are marked by peculiar bands, usually sinuous, which are termed *vittæ*. The curious *Biddulphia*, whose self-division has already been described (§ 176), belongs to this group; its frustules have a very peculiar external form (Fig. 81), and they are believed to be divided internally by partitions which correspond to the external ribbings. So far as is yet known, it is exclusively marine. Nearly allied to it, is the beautiful genus *Isthmia* (Fig. 96), which is also marine, and which grows attached to larger seaweeds, the basal frustule being very commonly attached by a stipes. In this, as in the preceding genus, the areolated structure of the surface is very conspicuous (Fig. 78), both in the valves and in the connecting 'hoop;' and this hoop, being silicified, not only connects the two new frustules (as at *b*), until they have separated from each other, but, after such separation, remains for a time round one of the frustules, so as to give it a truncated appearance (*a*, *c*).

188. It is by the complete persistence of the siliceous hoop, that the frustules are held-together in that curious group of Diatomaceæ, which consists of a few genera whose cylindrical filaments bear a close external resemblance to those of *Confervaceæ*. The most important of these is *Melo-*

FIG. 96.

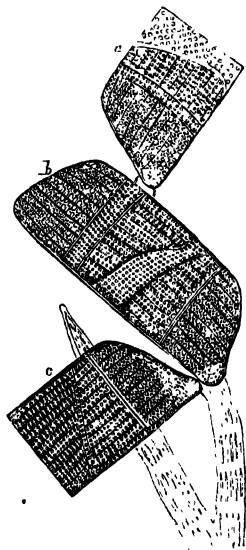
*Isthmia nervosa*.

seira (Figs. 97, 98), long since characterized as a plant by the Swedish algologist Agardh, but taken from the Vegetable

FIG. 97.

*Meloseira subflexilis.*

FIG. 98.

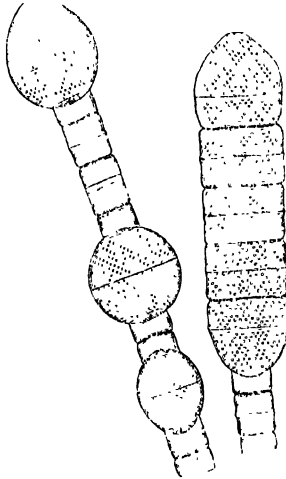
*Meloseira va*

kingdom with other Diatoms by Prof. Ehrenberg, who included its species in his genus *Gallionella*. Some of its species are marine, others fresh-water; one of the latter, the *M. ochracea*, seems to grow best in boggy pools containing a ferruginous impregnation; and it is stated by Prof. Ehrenberg to take-up from the water, and to incorporate with its own substance, a considerable quantity of iron. The filaments of *Meloseira* very commonly fall-apart at the slightest touch; and in the infusorial earths, in which some species abound, the frustules are always found detached (Fig. 102, *aa, dd*). The meaning of the remarkable difference in the sizes and forms of the frustules of the same filaments (Fig. 97, 98) has not yet been fully ascertained; but it seems to be related to the curious process of self-conjugation already described (§ 178). The sides of the valves are often marked with radiating striæ (Fig. 102, *dd*); and in some species they

have toothed or serrated margins, by which the frustules lock-together.

189. The Second tribe of Diatomaceæ, in which the frustules are completely enveloped by a gelatinous or membranaceous envelope, does not contain many forms so interesting as those which have been already described; and it will not be requisite to dwell long upon it. This envelope forms a *frond*, that holds-together all the frustules which have originated in the self-division of one individual; and it may either consist of an indefinite gelatinous mass, or rather aggregation of masses, in which the frustules are imbedded (Fig. 100), or of an indefinite

FIG. 99.

FIG. 100.

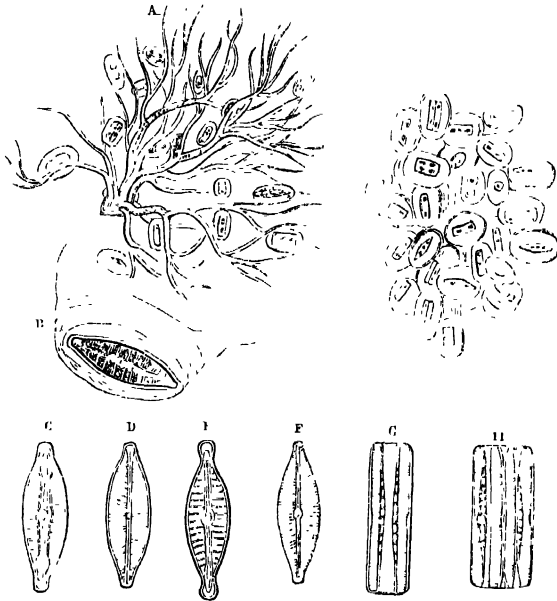

Fig. 99. *Mastogloia Smithi*;—A, entire stipes; B, frustule in its gelatinous envelope; C—F, different forms of frustule as seen in front view, G, side view, H, frustule undergoing subdivision.

Fig. 100. *Mastogloia lanceolata*.

cluster of such masses, supported by a stipes (Fig. 99), as in the genus *Mastogloia*; or it may have a definite shape, either globular, compressed, or filamentous, within which the frustules either lie scattered, as in *Dickieia* and *Berkeleyia*, or in rows, as in *Schizonema*, or in bundles, as in *Homocladia*. These are all, or nearly all, marine forms; and many of them present so strong a resemblance to the smaller filamentous Algæ, that they might easily be mistaken for such. Their frustules, however, when taken out of their containing tubes, frequently present so near an approximation, both in structure and markings, to members of the preceding groups of Diatomaceæ, that their close relationship to them cannot be questioned. Very strongly-marked varieties sometimes present themselves within the limits of a single species; thus the valves c, d, e, f (Fig. 99), would scarcely have been supposed to belong to the same specific type, were they not found upon the same stipes.—The careful study of these varieties, in every instance in which any disposition to variation shows itself, so as to *reduce* the enormous number of species with which our systematic treatises are loaded, is a pursuit of far greater real value, than the *multiplication* of species by the detection of such minute differences as may be presented by forms discovered in newly-explored localities; such differences, as already pointed-out, being probably, in a large proportion of cases, the result of the multiplication of some one form, which, under modifying influences that we do not yet understand, has departed from the ordinary type. The more faithfully and comprehensively this study is carried-out, in *any* department of Natural History, the more does it prove that the range of variation is far more extensive than had been previously imagined; and this is especially-likely to be the case with such humble organisms as those we have been considering; since they are obviously more influenced than are those of higher types, by the conditions under which they are developed; whilst, from the very wide geographical range through which the same forms are diffused, they are subject to very great diversities of such conditions.

190. The general habits of this most interesting group cannot be better stated than in the words of Prof. W. Smith, from whose admirable Monograph the Author has drawn the greater part of his materials for the foregoing account of it.*

* The Author has great pleasure in here acknowledging the liberality of Messrs. Smith and Beck, who have allowed him, not only to make free use of this volume, but also to copy as many as he desired of the admirable series

“The Diatomaceæ inhabit the sea, or fresh water; but the species peculiar to the one, are never found in a living state in any other locality; though there are some which prefer a medium of a mixed nature, and are only to be met-with in water more or less brackish. The latter are often found in great abundance and variety in districts occasionally subject to marine influences, such as marshes in the neighbourhood of the sea, or the deltas of rivers, where, on the occurrence of high tides, the freshness of the water is affected by percolation from the adjoining stream, or more directly by the occasional overflow of its banks. Other favourite habitats of the Diatomaceæ are stones of mountain streams or water-falls, and the shallow pools left by the retiring tide at the mouths of our larger rivers. They are not, however, confined to the localities I have mentioned,—they are, in fact, most ubiquitous, and there is hardly a roadside ditch, water-trough, or cistern, which will not reward a search, and furnish specimens of the tribe.” Such is their abundance in some rivers and estuaries, that their multiplication is affirmed by Prof. Ehrenberg to have exercised an important influence in blocking-up harbours and diminishing the depth of channels!—Of their extraordinary abundance in certain parts of the ocean, the best evidence is afforded by the observations of Dr. W. J. Hooker upon the Diatomaceæ of the southern seas; for within the Antarctic Circle, they are rendered peculiarly conspicuous by becoming enclosed in the newly-formed ice, and by being washed-up in myriads by the sea on to the ‘pack’ and ‘bergs,’ everywhere staining the white ice and snow of a pale ochreous brown. A deposit of mud, chiefly consisting of the siliceous loriceæ of Diatomaceæ, not less than 400 miles long and 120 miles broad, was found at a depth of between 200 and 400 feet, on the flanks of Victoria Land in 78° South latitude; of the thickness of this deposit no conjecture could be formed; but that it must be continually increasing is evident, the silex of which it is in a great measure composed being indestructible. A fact of peculiar interest in connection with this deposit, is its extension over the submarine flanks of Mount Erebus, an active volcano of 12,400 feet elevation; since a communication between the ocean-waters and the bowels of a volcano, such as there are other reasons for believing to be

of illustrations which have been executed for it by Mr. Tuffen West, many of them still unpublished. All the figures of Diatomaceæ, given in this Manual, except Figs. 80 and 85, which are drawn from nature, and Figs. 101, 102, which are copied from Prof. Ehrenberg, are as exact copies of Mr. West's lithographs as the best Wood-engraving can produce.

occasionally formed, would account for the presence of Diatomaceæ in volcanic ashes and pumice, which was discovered by Prof. Ehrenberg. It is remarked by Dr. Hooker, that the universal presence of this invisible vegetation throughout the South Polar Ocean, is a most important feature; since there is a marked deficiency, in this region, of higher forms of

FIG. 101.



Fossil Diatomaceæ, &c. from Oran:—a, a, a, Coscinodiscus; b, b, b, Actinocyclus; c, Dictyochya fibula; d, Lithasteriseus radiatus; e, Spongolithis acicularis; f, f, Grammatophora parallela (side view); g, g, Grammatophora angulosa (front view)

vegetation; and were it not for them, there would neither be food for aquatic animals, nor (if it were possible for these to maintain themselves by preying on one another) could the ocean-waters be purified of the carbonic acid which animal respiration and decomposition would be continually imparting to it.—It is interesting to observe, that some species of

marine Diatomaceæ are found through every degree of latitude between Spitzbergen and Victoria Land; whilst others seem limited to particular regions.—One of the most singular instances of the preservation of Diatomaceous forms, is their existence in Guano; into which they must have passed from the intestinal canals of the birds of whose accumulated excrement that substance is composed, those birds having received them, it is probable, from shell-fish, to which these minute organisms serve as ordinary food (§ 192).

191. The indestructible nature of the epiderms of *Diatomaceæ* has also served to perpetuate their presence in numerous localities, from which their living forms have long since disappeared; for the accumulation of sediment formed by their successive production and death, either on the bed of the ocean, or on the bottoms of fresh-water lakes, gives-rise to deposits which may attain considerable thickness, and which, by subsequent changes of level, may come to form part of the dry land. Thus very extensive siliceous strata, consisting almost entirely of marine *Diatomaceæ*, are found to alternate, in the neighbourhood of the Mediterranean, with calcareous strata, chiefly formed of *Foraminifera* (Chap. x.); the whole series being the representative of the Chalk formation of Northern Europe, in which the siliceous that was probably deposited at first in this form, has undergone conversion into *flint*, by agencies hereafter to be considered (Chaps. x., xix.). Of the Diatomaceous composition of these strata, we have a characteristic example in Fig. 101, which represents the fossil Diatomaceæ of Oran in Algeria. The so-called 'infusorial earth' of Richmond in Virginia, and that of Bermuda, also marine deposits, are very celebrated among Microscopists for the number and beauty of the forms they have yielded; the former constitutes a stratum of 18 feet in thickness, underlying the whole city, and extending over an area whose limits are not known. Several deposits of more limited extent, and apparently of fresh-water origin, have been found in our own islands; as for instance at Dolgelly in North Wales, at Lough Mourne in Ireland (Fig. 102), and in the island of Mull in Scotland. Similar deposits in Sweden and Norway are known under the name of *berg-mehl* or mountain-flour; and in times of scarcity, the inhabitants of those countries are accustomed to mix these substances with their dough in making bread. This has been supposed merely to have the effect of giving increased bulk to their loaves, so as to render the really-nutritive portion more satisfying.

But as the berg-mehl has been found to lose from a quarter to a third of its weight by exposure to a red-heat, there seems a

FIG. 102.

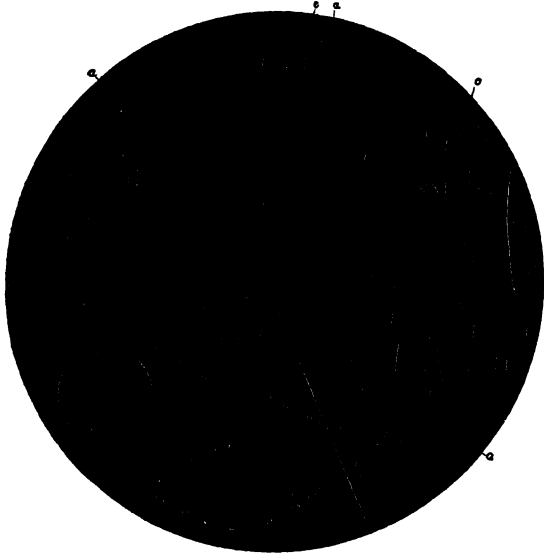

Fossil Diatomaceæ, &c. from Mourne mountain, Ireland:—*a, a, a*, Gaillonella (Meloseira) procera, and *G. granulata*; *d, d, d*, *G. biseriata* (side view); *b, b*, *Surirella plicata*; *c*, *S. craticula*; *k*, *S. caldonica*; *e*, *Gomphonema gracile*; *f*, *Cocconema fusidium*; *g*, *Tabellularia vulgaris*; *h*, *Pinnularia daetylus*; *i*, *P. nobilis*; *l*, *Synedra ulna*.

strong probability that it contains organic matter, which renders it nutritious in itself.—When thus occurring in strata of a fossil or sub-fossil character, the Diatomaceous deposits are generally distinguishable as white or cream-coloured powders of extreme fineness.

192. For collecting fresh *Diatomaceæ*, three general methods are to be had—recourse to, which have been already described (§§ 143, 171). “Their living masses,” says Prof. W. Smith, “present themselves as coloured fringes attached to larger plants, or forming a covering to stones or rocks in cushion-

like tufts—or spread over their surface as delicate velvet—or depositing themselves as a filmy stratum on the mud, or intermixed with the scum of living or decayed vegetation floating on the surface of the water. Their colour is usually a yellowish-brown of a greater or less intensity, varying from a light chesnut, in individual specimens, to a shade almost approaching black in the aggregated masses. Their presence may often be detected without the aid of a microscope, by the absence, in many species, of the fibrous tenacity which distinguishes other plants; when removed from their natural position, they become distributed through the water, and are held in suspension by it, only subsiding after some little time has elapsed.” Notwithstanding every care, the collected specimens are liable to be mixed with much foreign matter, this may be partly got-rid-of by repeated washings in pure water, and, by taking advantage, at the same time, of the different specific gravities of the Diatoms and of the intermixed substances, to secure their separation. Sand, being the heaviest, will subside first; fine particles of mud, on the other hand, will float after the Diatoms have subsided. The tendency which the Diatomaceæ have, to make their way towards the light, will afford much assistance in procuring the free forms in a tolerably clean state; for if the gathering which contains them be left undisturbed for a sufficient length of time, in a shallow vessel exposed to the sunlight, they may be skimmed from the surface. The marine forms must be looked for upon sea-weeds, and in the fine mud or sand of soundings or dredgings; they are frequently found also, in considerable numbers, in the stomachs of the oyster, scallop, whelk, and other Mollusks, especially the ‘bivalves,’ in those of the crab and lobster, and even in those of the sole, turbot, and other ‘flat-fish.’ “Several species,” says Prof. W. Smith, “rarely or never occurring in my usual haunts, have been supplied in abundance by the careful dissection of the above microphagists.” The separation of the Diatoms from the other contents of these stomachs, must be accomplished by the same process as that by which they are obtained from Guano or the calcareous Infusorial Earths; of this, the following are the most essential particulars. The guano or earth is first to be washed several times in pure water, which should be well stirred, and the sediment then allowed to subside for some hours before the water is poured-off, since, if it be decanted too soon, it may carry the lighter forms away with it. Some kinds of earth have so little impurity, that one washing suffices; but in any case it

is to be continued so long as the water remains coloured. The deposit is then to be treated, in a flask or test tube, with hydrochloric (muriatic) acid; and after the first effervescence is over, a gentle heat may be applied. As soon as the action has ceased, and time has been given for the sediment to subside, the acid should be poured-off, and another portion added; and this should be repeated as often as any effect is produced. When hydrochloric acid ceases to act, strong nitric acid should be substituted; and after the first effervescence is over, a continued heat of about 200° should be applied for some hours. When sufficient time has been given for subsidence, the acid may be poured-off, and the sediment treated with another portion; and this is to be repeated, until no further action takes place. The sediment is then to be washed, until all trace of the acid is removed; and if there have been no admixture of siliceous sand in the earth or guano, this sediment will consist almost entirely of Diatomacæ, with the addition, perhaps, of Sponge-spicules. The separation of siliceous sand, and the subdivision of the entire aggregate of Diatoms into the larger and the finer kinds, may be accomplished by stirring the sediment in a tall jar of water, and then, while it is still in motion, pouring-off the supernatant fluid as soon as the coarser particles have subsided; this fluid should be set aside, and, as soon as a finer sediment has subsided, it should again be poured-off; and this process may be repeated three or four times at increasing intervals, until no further sediment subsides after the lapse of half an hour. The first sediment will probably contain all the sandy particles, with, perhaps, some of the largest Diatoms, which may be picked-out from among them; and the subsequent sediments will consist almost exclusively of Diatoms, the sizes of which will be so graduated, that the earliest sediments may be examined with the lower powers, the next with the medium powers, while the latest will require the higher powers,—a separation which is attended with great convenience.*

193. The mode of mounting specimens of Diatomacæ, will depend upon the purpose which they are intended to serve. If they can be obtained quite fresh, and it be desired that they should exhibit, as closely as possible, the appearance

* A somewhat more complicated method of applying the same principle, is described by Mr. Okeden in the "Quart. Journ. of Microsc. Science," vol. iii. p. 168.—The Author believes, however, that the method above described will answer every purpose.

presented by the living plants, they should be put-up in distilled water within cement-cells (§ 134); but if they are not thus mounted within a short time after they have been gathered, about a sixth part of alcohol should be added to the water. If it be desired to exhibit the stipitate forms in their natural parasitism upon other aquatic plants, the entire mass may be mounted in Deane's gelatine (§ 131), in a deeper cell; and such a preparation is a very beautiful object for the black-ground illumination. If, on the other hand, the minute structure of the siliceous envelopes is the feature to be brought into view, the fresh Diatoms must be boiled in nitric or hydrochloric acid, which must then be poured-off (sufficient time being allowed for the deposit of the residue), and the sediment, after repeated washings, is to be either mounted in balsam in the ordinary manner (§ 128), or, if the species have markings that are peculiarly difficult of resolution, is to be set-up dry between two pieces of thin-glass (§ 122). In order to obtain a satisfactory view of these markings, object-glasses of very wide angle of aperture are required, and all the refinements which have recently been introduced into the methods of Illumination, need to be put in practice. (Chaps. III., IV.)—It will often be convenient to mount certain particular forms of Diatomaceæ separately from the general aggregate; but, on account of their minuteness, they cannot be selected and removed by the usual means. The larger forms, which may be readily distinguished under a simple microscope, may be taken-up by a camel-hair pencil, which has been so trimmed as to leave two or three hairs projecting beyond the rest. But the smaller can only be dealt-with by a single fine bristle or stout sable-hair, which may be inserted into the cleft-end of a slender wooden handle; and if the bristle or hair should be split at its extremity in a brush-like manner, it will be particularly useful. Such split hairs (as Dr. Redfern first noticed) may always be found in a shaving-brush which has been for some time in use. Those should be selected, which have thin split portions so closely in contact, that they appear single until touched at their ends. When the split extremity of such a hair touches the glass slide, its parts separate from each other to an amount proportionate to the pressure; and, on being brought-up to the object, first pushed to the edge of the fluid on the slide, may generally be made to seize it. Supposing that we wish to select certain particular forms, from a Diatomaceous sediment which has been obtained by the preceding processes;—

either of the two following modes may be put in practice. A small portion of the sediment being taken-up in the dipping-tube, and allowed to escape upon the slide, so as to form a long narrow line upon it, this is to be examined with the lowest power with which the object we are in-search-of can be distinguished (the erector and draw-tube, §§ 43, 44, will here be very useful); and when one of the specimens has been found, it may be taken-up, if possible, on the point of the hair, and transferred to a new slide, to which it may be made to adhere by first breathing on its surface. But if it be found impracticable thus to remove the specimens, on account of their minuteness, they may be pushed to one side of the slide on which they are lying; all the remainder of the sediment which it is not desired to preserve, may be washed-off; and the objects may then be pushed-back into the middle of the slide, and mounted in any way that may be desired.

194. *Palmellaceæ*.—To the little group of Plants which is ranked under this designation, those two genera belong, which have been already cited as illustrations of the humblest types of vegetation (§§ 150, 152); and the other forms which are associated with these, are scarcely less simple in their essential characters, though sometimes attaining considerable dimensions. They all grow either on damp surfaces, or in fresh or salt water; and they may either form (1) a mere powdery layer, of which the component particles have little or no adhesion to each other, or they may present themselves (2) in the condition of an indefinite slimy film, or (3) in that of a tolerably firm and definitely-bounded membranous 'froud.'—The *first* of these states we have seen to be characteristic of *Palmogleæ* and *Protococcus*: the new cells which are originated by the process of duplicative subdivision, usually separating from each other after a short time; and even where they remain in cohesion, nothing like a froud or membranous expansion being formed. The 'red snow,' which sometimes colours extensive tracts in Arctic or Alpine regions, penetrating even to the depth of several feet, and vegetating actively at a temperature which reduces most plants to a state of torpor, is generally considered to be a species of *Protococcus*, but as its cells are connected by a tolerably-firm gelatinous investment, it would rather seem to be a *Palmella*.—The *second* is the condition of the genus *Palmella*; of which one species, the *P. cruenta*, usually known under the name of 'gory dew,' is common on damp walls and shady places, sometimes extending itself over a considerable area as a tough gelatinous mass, of the

colour and general appearance of coagulated blood. A characteristic illustration of it is also afforded by the *Hæmatococcus sanguineus* (Fig. 103), which chiefly differs from Pal-

FIG. 103.

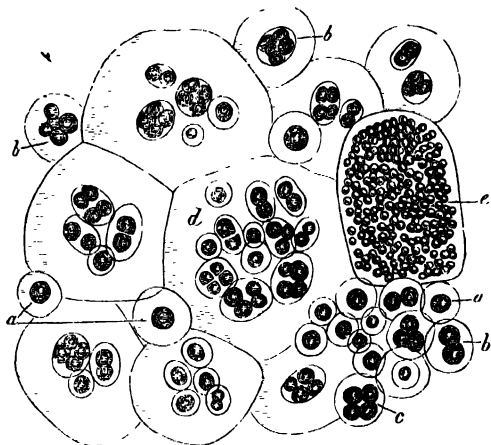

Hæmatococcus sanguineus, in various stages of development.—*a*, single cells, enclosed in their mucous envelope; *b*, *c*, clusters formed by subdivision of parent-cell; *d*, more numerous cluster, its component cells in various stages of division; *e*, large mass of young cells, formed by the continuance of the same process, and enclosed within a common mucous envelope.

mella in the partial persistence of the walls of the parent-cells, so that the whole mass is subdivided by partitions, which inclose a larger or smaller number of cells originating in the subdivision of their contents. Besides increasing in the ordinary mode of binary multiplication, the Palmella-cells seem occasionally to rupture and diffuse their granular contents through the gelatinous stratum, and thus to give origin to a whole cluster at once, as seen at *e*; after the manner of other simple Plants to be presently described (§ 195), save that these minute segments of the endochrome, having no power of spontaneous motion, cannot be ranked as Zoospores. The gelatinous masses of the Palmellæ are frequently found to contain parasitic growths, formed by the extension of other plants through their substance; but numerous branched fila-

ments sometimes present themselves, which, being traceable into absolute continuity with the cells, must be considered as properly appertaining to them. Sometimes these filaments radiate in various directions from a single central cell, and must at first be considered as mere extensions of this; their extremities dilate, however, into new cells; and, when these are fully formed, the tubular connections close-up, and the cells become detached from each other.* This is obviously an additional mode of increase by *gemmation*; analogous to that which we shall meet with among the *Confervaceæ* (§ 198).—Of the *third* condition, we have an example in the curious *Palmodictyon* described by Kutzing; the frond of which appears to the naked eye like a delicate network consisting of anastomosing branches, each composed of a single or double row of large vesicles, within every one of which is produced a pair of elliptical cellulæ that ultimately escape as ‘zoospores.’—The alternation between the ‘motile’ form and the ‘still’ or resting form, which has been described as occurring in *Protococcus* (§§ 153—155), has been observed in several other forms of this group; and it seems obviously intended, like the production of ‘zoospores,’ to secure the dispersion of the plant, and to prevent it from choking itself by overgrowth in any one locality.—No other form of the true Generative process, than the ‘conjugation’ of two cells, and the formation of a spore by the reunion of their contents, has yet been observed among the members of this family; and as this has only been witnessed in a few of them, it is probable that we do not yet know by any means the whole of their life-history. And from the close resemblance which many reputed *Palmellaceæ* bear to the early stages of higher Plants (Fig. 10 t, A, B, C), there is considerable doubt whether they ought to be regarded in the light of distinct and complete organisms, or whether they are anything else than embryonic forms of more elevated types. Here again, therefore, there is an ample field for investigation to the Microscopist who desires to employ himself in extending the boundaries of Science, and in perfecting our very imperfect acquaintance with these humble but most interesting and instructive types of Vegetation.

195. Notwithstanding the very definite form and large size

* Although the Authors of the “Micrographic Dictionary” throw doubt upon this fact (p. 487), yet the writer, having had the opportunity of verifying the observations of that most accurate Algologist, Mr. Thwaites, can entertain no doubt of their correctness. (See “Ann. of Nat. Hist.” N. S., vol. ii., p. 313.)

attained by the fronds or leafy expansions of the *Ulvaceæ*, to which group belong the grass-green sea-weeds (or 'lavers') found on every coast, yet their essential structure differs but very little from that of the preceding group; and the principal advance is shown in this, that the cells, when multiplied by binary subdivision, not only remain in firm connection with each other, but possess a very regular arrangement (in virtue of the determinate plan on which the subdivision takes-place), and form a regular membranous stratum. The mode in which this frond is produced, is best understood by studying the history of its development, some of the principal phases of which are seen in Fig. 104; for the isolated cells (A), in which it originates, resembling in all points those of a *Proto-coccus*, give rise, by their successive subdivisions in determinate directions, to such regular clusters as those seen at B and C, or to such confervoid filaments as that shown at D. A continuation of the same regular mode of subdivision, taking-place alternately in two directions, may at once extend the clusters B and C into leaf-like expansions; or, if the filamentous stage be passed-through (different

FIG. 104.

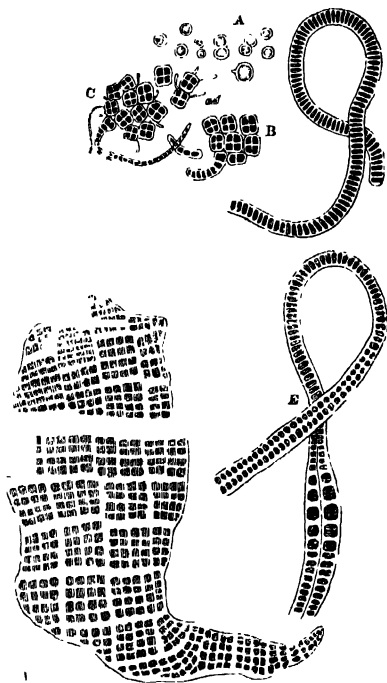

Successive stages of development of *Ulva*.

species presenting variations in the history of their development), the filament increases in breadth as well as in length (as seen at *E*), and finally becomes such a frond as is shown at *F*, *G*. In the simple membranous expansions thus formed, there is no approach to a 'differentiation' of parts, by even the semblance of a formation of root, stem, and leaf, such as the higher Algæ present; every portion is the exact counterpart of every other; and every portion seems to take an equal share in the operations of growth and reproduction. Each cell is very commonly found to exhibit an imperfect partitioning into four parts, preparatory to multiplication by double subdivision; and the entire frond usually shows the groups of cells arranged in clusters containing some multiple of four.—Besides this continuous increase of the individual frond, however, we find in most species of *Ulva* a provision for extending the plant by the dispersion of 'zoospores;' for the endochrome (Fig. 105, *a*)

FIG. 105.

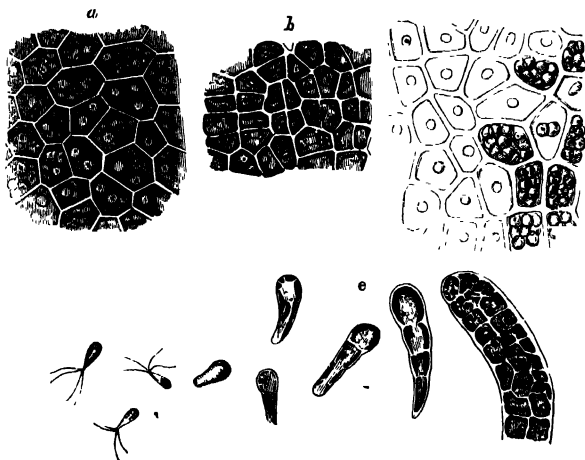

Formation of Zoospores in *Phycoseris gigantea* (*Ulva latissima*);—*a*, portion of the ordinary frond; *b*, cells in which the endochrome is beginning to break-up into segments; *c*, cells from the boundary between the coloured and colourless portion, some of them containing zoospores, others being empty; *d*, ciliated zoospores, as in active motion; *e*, subsequent development of the zoospores.

subdivides into numerous segments (as at *b* and *c*), which at first are seen to lie in close contact within the cell that contains them, then begin to exhibit a kind of restless motion, and at last pass forth through an aperture in the cell-wall, acquire four or more cilia (*d*), and swim freely through the water for some time. At last, however, they come to rest, attach themselves to some fixed point, and begin to grow into clusters or filaments (*e*), in the manner already described. The walls of the cells which have thus discharged their endochrome, remain as colourless spots on the frond; sometimes these are intermingled with the portions still vegetating in the usual mode; but sometimes the whole endochrome of one portion of the frond may thus escape in the form of zoospores, thus leaving behind it nothing but a white flaccid membrane. If the Microscopist who meets with a frond of an *Ulva* in this condition, should examine the line of separation between its green and its coloured portion, he may not improbably meet with cells in the very act of discharging their zoospores, which 'swarm' around their points of exit, very much in the manner that Animalcules are often seen to do around particular spots of the field of view, and which might easily be taken for true Infusoria; but on carrying his observations further, he would see that similar bodies are moving *within* cells a little more remote from the dividing line, and that, a little further still, they are obviously but masses of endochrome in the act of subdivision.* —Of the true Generative process in the *Ulvaceæ*, nothing whatever is known; and it is consequently altogether uncertain whether it takes place by simple conjugation, or according to that more truly sexual method which will be presently described. Here, again, therefore, is an unsolved problem of the greatest physiological interest, which probably requires nothing more for its solution, than patient and discriminating study. And the Author would point out, that it is by no means unlikely that the generative process may not be performed in the complete plant, but, as in the *Ferus*, (§ 219) in the early product of the development of the zoospore.—Although the typical *Ulvaceæ* are marine, yet there are several fresh-water species; and there are some which can even vegetate on damp surfaces, such as those of rocks or garden-walks kept moist by the percolation of water.

* Such an observation the Author had the good fortune to make in the year 1842, when the emission of zoospores from the *Ulvaceæ*, although it had been described by the Swedish algologist Agardh, had not been seen (he believes) by any British naturalist.

196. The *Oscillatoriaceæ* constitute another tribe of simple Plants, of great interest to the Microscopist, on account both of the extreme simplicity of their structure, and of the peculiar animal-like movements which they exhibit. They are continuous tubular filaments, formed by the elongation of their primordial cells, usually lying together in bundles or in strata, sometimes quite free, and sometimes invested by a gelatinous matrix. The endochrome which they contain usually exhibits some degree of transverse striation, as if breaking-up into short segments by the division of the tube into cells; but this division is never perfected by the formation of complete partitions; and the filaments ultimately break-up into distinct joints, the fragments of endochrome, which are to be regarded as *gonidia*, usually escaping from their sheaths, and giving origin to new filaments. These plants are commonly of some shade of green, often mingled, however, with blue; but not unfrequently they are of a purplish hue, and are sometimes so dark, as, when in mass, to seem nearly black. They occur not only in fresh, stagnant, brackish, and salt waters (certain species being peculiar to each), but also in mud, on wet stones, or on damp ground. Their very curious movements constitute the most remarkable feature in their history. These are described by Dr. Harvey* as of three kinds; first, a pendulum-like movement from side to side, performed by one end, whilst the other remains fixed so as to form a sort of pivot; second, a movement of flexure of the filament itself, the oscillating extremity bending-over first to one side and then to the other, like the head of a worm or caterpillar seeking something on its line of march; and third, a simple onward movement of progression. "The whole phenomenon," continues Dr. H., "may perhaps be resolved into a spiral onward movement of the filament. If a piece of the stratum of an *Oscillatoria* be placed in a vessel of water, and allowed to remain there for some hours, its edge will first become fringed with filaments, radiating as from a central point, with their tips outwards. These filaments, by their constant oscillatory movements, are continually loosened from their hold on the stratum, cast into the water, and at the same time propelled forward; and as the oscillation continues after the filament has left its nest, the little swimmer gradually moves along, till it not only reaches the edge of the vessel, but often, as if in the attempt to escape confinement—continues its voyage up the sides, till it is stopped by dryness. Thus in a very short

* "Manual of British Marine Algae," p. 220.

time, a small piece of *Oscillatoria* will spread itself over a large vessel of water." This rhythmical movement, impelling the filaments in an undeviating onward course, is evidently of a nature altogether different from the truly spontaneous motions of Animals; and must be considered simply as the expression of certain vital changes taking-place in the interior of the cells. It is greatly influenced by temperature and light, being much more active in warmth and sunshine than in cold and shade; and it is checked by any strong chemical agents. The true Generation of *Oscillatoriaceæ* is as yet completely unknown; and it does not seem at all unlikely that these plants may be the 'motile' forms of some others, which, in their 'still' condition, present an aspect altogether different.—Nearly allied to the preceding, is the little tribe of *Nostochaceæ*; which consists of distinctly-beaded filaments, lying in firmly-gelatinous fronds of definite outline. The filaments are usually simple, though sometimes branched; and are almost always curved or twisted, often taking a spiral direction. The masses of jelly in which they are imbedded are sometimes globular or nearly so, and sometimes extend in more or less regular branches; they frequently attain a very considerable size; and as they occasionally present themselves quite suddenly (especially in the later part of the autumn, on damp garden-walks), they have received the name of 'fallen stars.' They are not always so suddenly produced, however, as they appear to be; for they shrink-up into mere films in dry weather, and expand again with the first shower. These plants multiply themselves, like the *Oscillatoria*, by the subdivision of their filaments, the portions of which escape from the gelatinous mass wherein they were imbedded, and move slowly through the water in the direction of their length; after a time they cease to move, and a new gelatinous envelope is formed around each piece, which then begins not only to increase in length by the transverse subdivision of its segments, but also to double itself by longitudinal fission, so that each filament splits lengthways (as it were) into two new ones. By the repetition of this process, a mass of new filaments is produced, the parts of which are at first confused, but afterwards become more distinctly separated by the interposition of the gelatinous substance developed between them. Besides the ordinary cells of the beaded filaments, two other kinds are occasionally observable; namely 'vesicular cells' of larger size than the rest (sometimes occurring at one end of the filaments, sometimes in their centre, and sometimes at

intervals along their whole length), which are destitute of endochrome, and are sometimes furnished with cilia; and 'sporangial cells,' which seem like enlarged forms of the ordinary cells, and which are usually found in the neighbourhood of the preceding. There is very strong evidence from analogy, that the 'vesicular cells' are 'antheridia' or sperm-cells, and that the 'sporangial cells' contain germs, which when fertilized by the antherozoids, and set free, become 'resting-spores,' as in certain members of the family to be next noticed.

197. Although many of the plants belonging to the family *Siphonaceæ* attain a considerable size, and resemble the higher Sea-weeds in their general mode of growth, yet they retain a simplicity of structure so extreme, that it apparently requires them to be ranked among the Protophytes. They are inhabitants both of fresh-water and of the sea, and consist of very large tubular cells, which commonly extend themselves into branches, so as to form an arborescent frond. These branches, however, are seldom separated from the stem by any intervening partition; but the whole frond is composed of a simple continuous tube, the entire contents of which may be readily pressed-out through an orifice made by wounding any part of the wall. The *Vaucheria*, named after the Genevese botanist whose admirable researches on the fresh-water Confervæ have been already referred-to (p. 7), may be selected as a particularly-good illustration of this family; its history having been pretty-completely made out. Most of its species are inhabitants of fresh-water; but some are marine; and they commonly present themselves in the form of cushion-like masses, composed of irregularly branching filaments, which, although they remain distinct, are densely tufted together, and variously interwoven. The formation of moving gonidia or 'zoospores' may be readily observed in these plants, the whole process usually occupying but a very short time. The extremity of one of the filaments usually swells-up in the form of a club, and the endochrome accumulates in it, so as to give it a darker hue than the rest: a separation of this part from the remainder of the filament, by the interposition of a transparent space, is next seen; a new envelope is then formed around the mass thus cut-off; and at last the membranous wall of the investing tube gives-way, and the 'zoospore' escapes, not, however, until it has undergone marked changes of form, and exhibited curious movements. Its motions continue for some time after its escape, and are then plainly

seen to be due to the action of the cilia with which its whole surface is clothed. If it be placed in water in which some carmine or indigo has been rubbed, the coloured granules are seen to be driven in such a manner as to show that a powerful current is produced by their propulsive action, and a long track is left behind it. When it meets with an obstacle, the ciliary action not being arrested, the zoospore is flattened against the object; and it may thus be compressed, even to the extent of causing its endochrome to be discharged. The cilia are best seen, when their movements have been retarded or entirely arrested by means of opium, iodine, or other chemical reagents. The motion of the spore continues for about two hours; but after the lapse of that time it soon comes to an end, and the spore begins to develop itself into a new plant. It has been observed by Unger, that the escape of the zoospores generally takes place towards 8 A.M.; to watch this phenomenon, therefore, the plant should be gathered the day before, and its tufts examined early in the morning. It is stated by Dr. Hassall, that he has seen the same filament give-off two or three zoospores successively. Their emission is obviously to be regarded as a method of increase by gemination, rather than as a generative act; and recent discoveries have shown that there exists in this humble plant a true process of Sexual Generation, as was, indeed, long ago suspected by Vaucher, though upon no sufficient grounds. The branching filaments are often seen to bear at their sides peculiar globular or oval capsular protuberances, sometimes separated by the interposition of a stalk, which are filled with dark endochrome; and these have been observed to give exit to large bodies covered with a firm envelope, from which, after a time, new plants arise. In the immediate neighbourhood of these 'capsules' are always found certain other projections, which, from being usually pointed and somewhat curved, have been named 'horns'; and these were supposed by Vaucher to fulfil the function of the anthers of flowering-plants. The recent observations of Pringsheim have shown that such is really the case; for the 'horns' are 'antheridia,' which, like those of the *Characeæ* (§ 202), produce antherozoids in their interior; whilst the capsules are 'germ-cells,' whose aggregate mass of endochrome is destined to become, when fertilized, the primordial cell of a new generation. The antherozoids, when set free from the antheridium, swarm over the exterior of the capsule, and have actually been seen to penetrate its cavity, through an aperture which oppor-

tunely forms in its wall, and to come into contact with the surface of its endochrome-mass, over which they diffuse themselves; there they seem to undergo dissolution, their contents mingling themselves with those of the germ-cell; and the endochrome-mass, which had previously no proper investment of its own, soon begins to form an envelope, which increases in thickness and strength, until it has acquired such a density as enables it to afford a firm protection to its contents. This body, possessing no power of spontaneous movement, is known as a 'resting-spore,' in contradistinction to the 'zoospores' already described; and it answers the purpose of a seed, in laying the foundation for a new generation, whilst the 'zoospores' merely multiply the individual by a process analogous to budding.—The Microscopist who wishes to study the development of zoospores, as well as several other phenomena of this low type of vegetation, may advantageously have recourse to the little plant termed *Achlya prolifera*, which grows parasitically upon the bodies of dead flies lying in the water, but also not unfrequently attaches itself to the gills of fish, and is occasionally found on the bodies of frogs. Its tufts are distinguishable by the naked eye, as clusters of minute colourless filaments; and these are found, when examined by the microscope, to be long tubes devoid of all partitions, extending themselves in various directions. The tubes contain a colourless slightly-granular protoplasm, the particles of which are seen to move slowly in streams along the walls, as in *Chara*, the currents occasionally anastomosing with each other (Fig. 106, c). Within about thirty-six hours after the first appearance of the parasite on any body, the protoplasm begins to accumulate in the dilated ends of the filaments, each of which is cut-off from the remainder by the formation of a partition; and within this dilated cell, the movement of the protoplasm continues for a time to be distinguishable. Very speedily, however, its endochrome shows the appearance of being broken-up into a large number of distinct masses, which are at first in close contact with each other and with the walls of the cell (Fig. 106, A), but which gradually become more isolated, each seeming to acquire a proper cell-wall; they then begin to move-about within the parent-cell; and, when quite mature, they are set-free by the rupture of its wall (B), to go-forth and form new attachments, and to develop themselves into tubiform cells resembling those from which they sprang. Each of these 'motile gonidia' is possessed of only two cilia; their movements are

not so powerful as those of the zoospores of *Vaucheria*; and they come to an end sooner. This plant forms 'resting

FIG. 106.

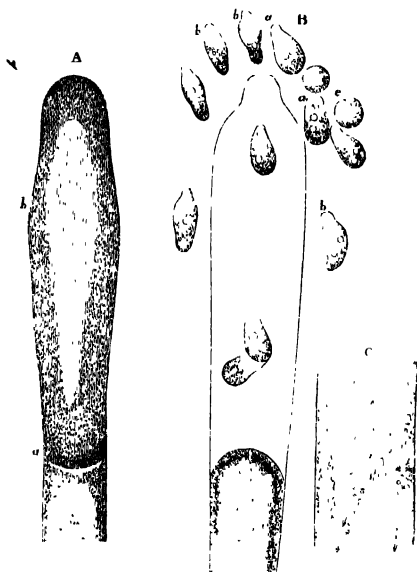

Development of *Achlya prolifera* —A, dilated extremity of a filament *b*, separated from the rest by a partition *a*, and containing young cells in progress of formation;—*b*, conceptacle discharging itself, and setting-free young cells, *a b c*.—*c*, portion of filament, showing the course of the circulation of granular protoplasm.

spores' also, like those of *Vaucheria*; and there is every probability that they are generated by a like sexual process. They may remain unchanged for a long time in water, when no suitable *nidus* exists for them; but will quickly germinate, if a dead insect or other suitable object be thrown-in. —One of the most curious forms of this group, is the *Hydrodictyon utriculatum*, which is found in fresh-water pools in the midland and southern counties of England. Its frond consists of a green open network of filaments, acquiring, when full-

grown, a length of from four to six inches, and composed of a vast number of cylindrical tubular cells, which attain the length of four lines or more, and adhere to each other by their rounded extremities, the points of junction corresponding to the knots or intersections of the network. Each of these cells may form within itself an enormous multitude (from 7000 to 20,000) of 'gonidia'; which, at a certain stage of their development, are observed in active motion in its interior; but of which groups are afterwards formed by their mutual adhesion, that are set free by the dissolution of their envelopes, each group giving origin to a new plant-net. Besides these bodies, however, certain cells produce from 30,000 to 100,000 more minute bodies of longer shape, each furnished with four long cilia and a red spot, which are termed by Braun 'microgonidia': these escape from the cell in a swarm, move freely in the water for some time, and then come to rest and sink to the bottom, where they remain heaped in green masses. What is their future history, has not yet been ascertained; but there is evidence from analogy that they are 'antheridial' cells, which have for their office to fecundate the true germ-cells by contained antherozoids. No development of 'resting spores', however, has yet been observed. The rapidity of the growth of this curious plant, is not one of the least remarkable parts of its history. The individual cells of which the net is composed, at the time of their emersion as gonidia, measure no more than 1-2500th of an inch in length; but in the course of a few weeks, they grow to a length of from 1-12th to 1-3rd of an inch.

198. Almost every pond and ditch contains some members of the family *Confervaceæ*; but they are especially abundant in moving water; and they constitute the greater part of those green threads, which are to be seen attached to stones, with their free ends floating in the direction of the current, in every running stream, and upon almost every part of the seashore, and which are commonly known under the name of 'silk-weeds' or 'crow-silk.' Their form is usually very regular; for each thread is a long cylinder, made-up by the union of a single file of short cylindrical cells united to each other by their flattened extremities; sometimes these threads give-off lateral branches, which have the same structure. The endochrome, though usually green, is occasionally of a brown or purple hue; it is sometimes distributed uniformly throughout the cell (as in Fig. 107), whilst in other instances it is arranged in a pattern of some kind, as a network or a spiral; but this

may be only a transitional stage in its development. The plants of this order are extremely favourable subjects for the study of the method of cell-multiplication by binary subdivision. This process usually takes place only in the *terminal* cell; and it may be almost always observed there, in some one of its stages. The first step is seen to be the subdivision of the endochrome, and the inflexion of the primordial utricle around it (Fig. 107 A, *a*); and thus there is gradually formed a sort of hour-glass contraction across the cavity of the parent-cell, by which it is divided into two equal halves (B). The two surfaces of the infolded utricle produce a double layer of cellulose-membrane between them; this is not confined, however, to the contiguous surfaces of the young cell, but takes place over the whole exterior of the primordial utricle, so that the new septum is continuous with new layers that are formed throughout the interior of the cellulose wall of the original cell (c).—Sometimes, however, as in *Conferva glomerata* (a common species), new cells may originate as branches from any part of the surface, by a process of budding; which, notwithstanding its difference of mode, agrees with that just described in its essential character, being the result of the subdivision

of the original cell. A certain portion of the primordial utricle seems to undergo increased nutrition, for it is seen to project, carrying the cellulose-envelope before it, so as to form a little protuberance; and this sometimes attains a considerable length, before any separation of its cavity

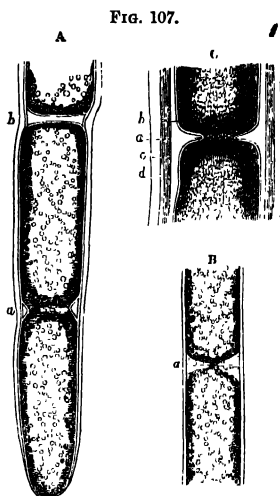

FIG. 107.
Process of cell-multiplication in *Conferva glomerata*.—A, portion of filament with incomplete separation at *a*, and complete partition at *b*; B, the separation completed, and new cellulose partition being formed at *a*; C, formation of additional layers of cellulose wall *c*, beneath the mucous investment *d*, and around the primordial utricle *a*, which encloses the endochrome *b*.

of the original cell. A certain portion of the primordial utricle seems to undergo increased nutrition, for it is seen to project, carrying the cellulose-envelope before it, so as to form a little protuberance; and this sometimes attains a considerable length, before any separation of its cavity

from that of the cell which gave origin to it, begins to take place. This separation is gradually effected, however, by the infolding of the primordial utricle, just as in the preceding case; and thus the endochrome of the branch-cell is completely severed from that of the stock. The branch then begins to elongate itself by the subdivision of its first-formed cell; and this process may be repeated for a time in all the cells of the filament, though it usually comes to be restricted at last to the terminal cell.—The *Confervaceæ* multiply themselves by 'zoospores,' which are produced within their cells, and are then set-free, just as in the *Ulvaceæ* (§ 195); in most of the genera, the endochrome of each cell divides into numerous zoospores, which are of course very minute; but in *Edogonium*,—a freshwater genus distinguished by the circular markings which form rings round the extremities of many of the cells, and by many interesting peculiarities of growth and reproduction,*—only a single large zoospore is set-free from each cell; and its liberation is accomplished by the almost complete fission of the wall of the cell through one of these rings, a small part only remaining unleft, which serves as a kind of hinge, whereby the two parts of the filament are prevented from being altogether separated. Sometimes the zoospore does not completely extricate itself from the parent-cell; and it may begin to grow in this situation, the root-like processes which it puts-forth, being extended into the cavity.—A true sexual generation has been observed in several *Confervaceæ*; and is probably universal throughout the group. Thus in *Sphaeroplea annulina*, according to the recent observations of Dr. Cohn,† the ring-like masses of endochrome, of which several are found in each cell, resolve themselves in certain of the cells into minute bodies resembling the antherozoids of *Chara* (Fig. 112, II), which, after moving freely within these cells, escape through apertures in their walls, and then penetrate apertures in the walls of certain other cells, within each of which the endochrome has coalesced into a globular mass; over this mass the antherozoids spread themselves, and seem to dissolve-away upon its surface; and after this process has taken-place, the mass of endochrome acquires a firm envelope, and becomes a 'resting spore,' which, when set-free by the rupture of the parent-cell-wall, germinates into a new plant.—A curious variation of this

* See the account of these processes in the "Micrographic Dictionary," p. 468.

† Monatsberichte der Königl. Akad. der Wissenschaften," Mai, 1855.

process is seen in *Edogonium*; for instead of the antherozoids escaping freely from the 'sperm-cells' which produced them, they are discharged *en masse*, included within a capsule which is furnished with cilia, and which so resembles a 'zoospore' as to be easily mistaken for it; and it is only when this has attached itself, and has set-free its contents by the falling-off of a sort of lid, that the antherozoids are enabled to perform their fertilizing office.—The same thing happens in some other Confervaceæ; in which, however, the antheridial capsules, being smaller than the zoospores, are distinguished as *microgonidia*, whilst the latter are known as *macrogonidia*. The offices of these different classes of reproductive bodies are only now beginning to be understood; and the enquiry is one so fraught with Physiological interest, and, from the facility of growing these plants in artificial Aquaria, may be so easily pursued, that it may be hoped that Microscopists will apply themselves to it so zealously, as not long to leave any part of it in obscurity.

199. The family *Conjugateæ* agrees with that of *Confervaceæ* in its mode of growth, but differs from it in the plan in which its generative process is performed; this being accomplished by an act of 'conjugation,' resembling that which has been described in the simplest Protophytes. These plants are not found so much in running streams, as in waters that are perfectly still, such as those of ponds, reservoirs, ditches, or marshy grounds; and they are for the most part unattached, floating freely at or near the surface, especially when buoyed-up by the bubbles of gas which are liberated from the midst of them under the influence of solar light and heat. In an early stage of their growth, whilst as yet the cells are undergoing multiplication by subdivision, the endochrome is commonly diffused pretty uniformly through their cavities (Fig. 109, A); but as they advance towards the stage of conjugation, the endochrome ordinarily arranges itself in regular spirals (B), but occasionally in some other forms. The act of 'conjugation' usually occurs between the cells of two distinct filaments, that happen to lie in proximity to each other; and all the cells of each filament generally take-part in it at once. The adjacent cells put-forth little protuberances, which come into contact with each other, and then coalesce by the breaking-down of the intervening partitions, so as to establish a free passage between the cavities of the conjugating cells. In some genera of this family (such as *Mesocarpus*), the conjugating cells pour their endochromes into a dilatation of the

passage that has been established between them; and it is there that they commingle, so as to form the spore or embryocell. But in the *Zygnema* (Fig. 108), which is among the commonest and best-known forms of Conjugatææ, the endochrome of one cell passes-over entirely into the cavity of the other; and it is within the latter that the spore is formed (c), the two endochromes coalescing into a single

FIG. 108.

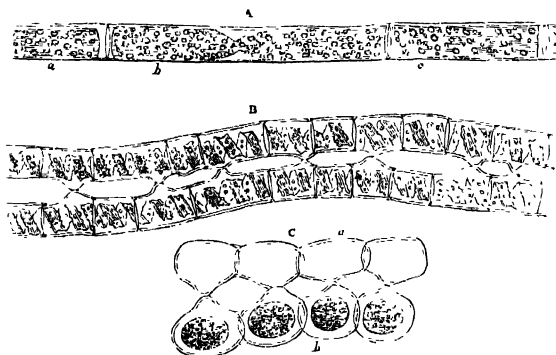

Various stages of the history of *Zygnema quininum*:—A, three cells, *a*, *b*, *c*, of a young filament, of which *b* is undergoing subdivision; B, two filaments in the first stage of conjugation, showing the spiral disposition of their endochromes, and the protuberances from the conjugating cells; C, completion of the act of conjugation, the endochromes of the cells of the filament *a* having entirely passed-over to those of filament *b*, in which the sporangia are formed.

mass, around which a firm envelope gradually makes its appearance. Further, it may be generally observed, that *all* the cells of one filament thus empty themselves, whilst *all* the cells of the other filaments become the recipients; here, therefore, we seem to have a foreshadowing of the sexual distinction of the generative cells into 'sperm-cells' and 'germ-cells,' which we have just seen to exist in the Convolvaceæ (§ 198). And this transition will be still more complete, if (as Itzigsohn has affirmed) the endochrome of certain filaments of *Spirogyra* breaks-up before conjugation into little spherical aggregations, which are gradually converted into nearly-colourless spiral filaments, having an active spontaneous motion, and

therefore corresponding precisely to the antherozoids of the truly sexual Protophytes.*

200. The *Chatophoraceæ* constitute another beautiful and interesting little group of Confervoid plants, of which some species inhabit the sea, whilst others are found in fresh and pure water, rather in that of gently-moving streams, however, than in strongly-flowing currents. Generally speaking, their

filaments put-forth lateral branches, and extend themselves into arborescent fronds; and one of the distinctive characters of the group is afforded by the fact, that the extremities of these branches are usually prolonged into bristle-shaped processes (Fig. 109). As in many preceding cases, these plants multiply themselves by the conversion of certain of their cells into 'zoospores'; and these, when set-free, are seen to be furnished with four large cilia. 'Resting-spores' have also been seen in many species;

FIG. 109.



Branches of *Chatophora elegans*, in the act of discharging ciliated zoospores, which are seen, as in motion, on the right.

* This group of plants seems to serve as the connecting link between those simple Protophytes in which the sexes are not yet differentiated, and those higher forms in which the distinction between the 'sperm-cells' and 'germ-cells' is very apparent. For let it be supposed that in *Sphaeroplea* (§ 198) a conjugation of two adjacent cells were to take place, at that stage in their development in which the endochrome is uniformly arranged in rings, no differentiation of sexes yet showing itself,—the process would in all respects correspond with that of the ordinary Conjugatæ. Again, whilst in *Mesocarpus*, the

and it is probable that these, as in *Confervaceæ*, are true generative products of the fertilization of the contents of 'germ-cells' by 'antherozoids' developed within 'sperm-cells' (§ 198).—Nearly allied to the preceding are the *Batrachospermeæ*, whose name is indicative of the strong resemblance which their beaded filaments bear to frog-spawn; these exhibit a somewhat greater complexity of structure, and afford objects of extreme beauty to the Microscopist. The plants of this family are all inhabitants of fresh water, and they are chiefly found in that which is pure and gently-flowing. "They are so extremely flexible," says Dr. Hassall, "that they obey the slightest motion of the fluid which surrounds them; and nothing can surpass the ease and grace of their movements. When removed from the water, they lose all form, and appear like pieces of jelly, without trace of organization; on immersion, however, the branches quickly resume their former disposition." Their colour is for the most part of a brownish-green; but sometimes they are of a reddish or bluish purple. The central axis of each plant is originally composed of a single file of large cylindrical cells laid end-to-end; but this is subsequently invested by other cells, in the manner to be presently described. It bears, at pretty regular intervals, whorls of short radiating branches, each of them composed of rounded cells arranged in a bead-like row (Fig. 110), and sometimes subdividing again into two, or themselves giving-off lateral branches. Each of the primary branches originates in a little protuberance from the primitive cell of the central axis, precisely after the manner of the lateral cells of *Conferva glomerata* (§ 198); as this protuberance increases in size, its cavity is cut-off by a septum, so as to render it an independent cell; and by the continual repetition of the process of dupli-

two conjugating cells appear to take (as in the *Desmidiæ*, § 169) a precisely similar share in the formation of their product, the first stage of differentiation into sperm-cells and germ-cells is manifested in *Zygnema*, by the passage of the whole endochrome of those of one filament into the cavities of the other, and by the formation of the spores within the latter. In *Spirogyra*, moreover, the endochrome of one set of cells becomes converted into antherozoids before conjugation, whilst that of the other aggregates into a sporangial mass; thus exhibiting the second stage of differentiation. Further, there are certain species which agree with the ordinary *Conjugatæ* in their general habit, and which form 'resting-spores' like theirs, but in which no conjugation has been observed; and it seems not improbable that in these, as in *Spheroplea*, the antherozoids make their way out of the sperm-cell by minute apertures in its wall, and swim freely about before finding their way into the germ-cell through the apertures in *its* wall;—still, however, performing by this means the very same act, as that which is accomplished by the more direct process of conjugation,—viz., the introduction of the contents of the sperm-cell into the interior of the germ-cell.

cative subdivision, this single cell becomes converted into a beaded filament. Certain of these branches, however, instead of radiating from the main axis, grow downwards upon it, so as to form a closely-fitting, investment, that seems properly to belong to it. Some of the radiating branches grow-out into long transparent points, like those of *Chaetophoraceæ*; and it does not seem by any means improbable, that these, like the 'horns' of *Vaucheria* (§ 197), are really antheridia. For within certain cells of other branches, 'resting-spores' are formed; by the agglomeration of which are produced the large dark bodies, that are seen in the midst of the whorls of branches (Fig. 110).

FIG. 110.

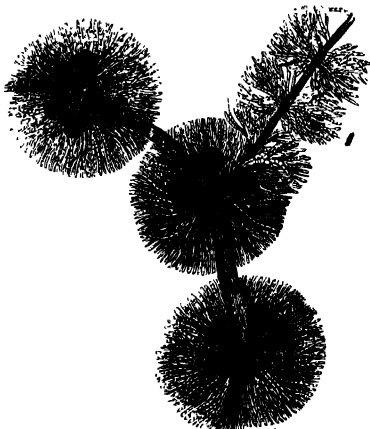
*Batrachospermum moniliforme.*

201. This seems the most appropriate place to consider a group of humble plants, having a peculiar interest for Microscopists,—that, namely, of *Characeæ*; in which we have a vegetative apparatus as simple as that of the Protophytes already described, whilst their reproductive apparatus is even more highly developed than that of the proper Algæ. They are for the most part inhabitants of fresh waters, and are found rather in such as are still, than in those which are in motion; one species, however, may be met-with in ditches whose waters are rendered salt by communication with the sea. They may be easily grown for the purposes of observation, in large glass jars exposed to the light; all that is necessary being to pour-off the water occasionally from the upper part of the vessel (thus carrying away a film that is apt to form on its surface), and to replace this by fresh water. Each plant is composed of an assemblage of long tubiform cells, placed end to end; with a distinct central axis, around which the

branches are disposed at intervals with great (Fig. 111, A). In one of the genera, *Nitella*, the stem and

FIG. 111.

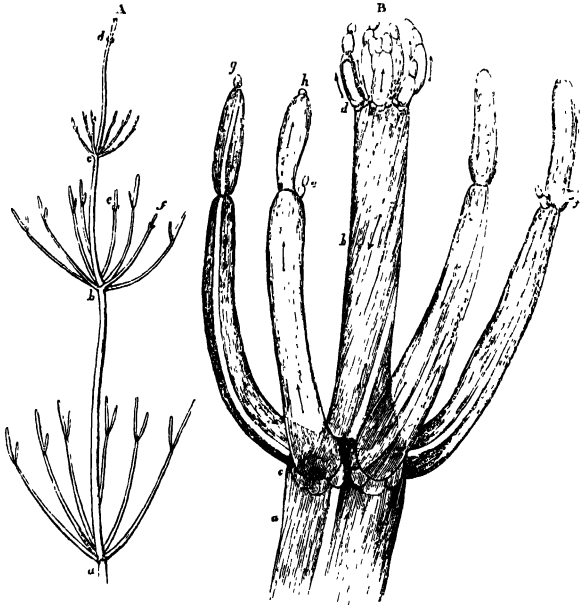

Nitella flexilis.—A, stem and branches of the natural size; *a, b, c, d*, four verticils of branches issuing from the stem; *e, f*, subdivision of the branches;—B, portion of the stem and branches enlarged; *a, b*, joints of stem; *c, d*, verticils; *e, f*, new cells sprouting from the sides of the branches; *g, h*, new cells sprouting at the extremities of the branches.

branches are simple cells, which sometimes attain the length of several inches; whilst in the true *Chara*, each central tube is surrounded by an envelope of smaller ones, which is formed as in *Batrachospermeæ*, save that the investing cells grow upwards as well as downwards from each joint, and meet each other on the stem half-way between the joints. Some species have the power of secreting carbonate of lime from

the water in which they grow, if this be at all impregnated with calcareous matter; and by the deposition of it beneath their teguments, they have gained their popular name of 'stone-worts.'—These humble plants have attracted much attention, in consequence of the facility with which the 'rotation,' or movement of fluid in the interior of the individual cells, may be seen in them. Each cell, in the healthy state, is lined by a layer of green oval granules, which cover every part, except two longitudinal lines that remain nearly colourless (Fig. 111, B); and a constant stream of semi-fluid matter, containing numerous jelly-like globules, is seen to flow over this green layer, the current passing up one side, changing its direction at the extremity, and flowing down the other side, the ascending and descending spaces being bounded by the transparent lines just mentioned. That the currents are in some way directed by the layer of granules, appears from the fact noticed by Mr. Varley,* that if accident damages or removes them near the boundary between the ascending and descending currents, a portion of the fluid of the two currents will intermingle by passing the boundary; whilst, if the injury be repaired by the development of new granules on the part from which they had been detached, the circulation resumes its regularity, no part of either current passing the boundary. In the young cells, however, the rotation may be seen, before their granular lining is formed. The rate of the movement is affected by anything which influences the vital activity of the plant; thus, it is accelerated by moderate warmth, whilst it is retarded by cold; and it may be at once checked by a slight electric discharge through the plant. The moving globules, which consist of starchy matter, are of various sizes; being sometimes very small, and of definite figure, whilst in other instances they are seen as large irregular masses, which appear to be formed by the aggregation of the smaller particles.† The

* "Transactions of the Microscopical Society" (First Series), vol. ii. p. 89.

† This interesting phenomenon may be readily observed, by taking a small portion of the plant out of the water in which it is growing, and either placing it in a large aquatic box (§ 68) or in the zoophyte-trough (§ 69), or laying it on the glass stage-plate (§ 67) and covering it with thin glass. The modification of the stage-plate which is termed the 'growing slide,' will enable the Microscopist to keep a portion of Chara under observation for many days together; and this is a much simpler and more convenient arrangement than the method devised by Mr. Varley for growing Chara in bottles; since the bottle requires a special 'phial-holder' for fixing it on the Microscope-stage, and the convexity of its surface produces some distortion of the image. The latter method, however, has its advantages for those who wish to make a special study or a frequent exhibition of the phenomenon in question;

production of new cells, for the extension of the stem or branches, or the origination of new whorls, is not here accomplished by the subdivision of the parent-cell, but takes place by the method of out-growth (Fig. 111, *b, e, f, g, h*), which, as already shown (§ 198), is nothing but a modification of the usual process of cell-multiplication; in this manner, the extension of the individual plant is effected with considerable rapidity. When these plants are well supplied with nutriment, and are actively vegetating under the influence of light, warmth, &c., they not unfrequently develop 'bulbels,' or gonidia of a peculiar kind, which serve the same purpose in multiplying the individual, as is answered by the zoospores of the simpler Protophytes: these are little clusters of cells, filled with starch, which sprout from the sides of the central axis, and then, falling off, evolve the long tubiform cells characteristic of the plant from which they were produced.*—The *Characeæ* may also be multiplied by artificial subdivision; the separated parts continuing to grow, under favourable circumstances, and developing themselves into the typical form.

202. The generative apparatus of *Characeæ* consists of two sets of bodies, both of which grow at the bases of the branches (Fig. 112, *A, B*); one set is known by the designation of 'globules,' the other by that of 'nucules.' The globules are really antheridia; whilst the nucules contain the germ-cells.—The 'globules,' which are nearly spherical, have an envelope made-up of eight triangular valves (*B, C*), often curiously marked, which enclose a nucleus of a light reddish colour; this nucleus is principally composed of a mass of filaments rolled-up compactly together; and each of these filaments (*C*) consists, like a *Conferva*, of a linear succession of cells. In every one of these cells there is formed, by a gradual change in its contents (the successive stages of which are seen at *D, E, F*), a spiral thread of two or three coils, which, at first motionless, after a time begins to move and revolve within the cell; and at last the cell-wall gives way, and the spiral thread makes its way out (*G*), partially straightens itself, and moves actively through the water for some time (*H*), in a tolerably determinate direction, by the lashing action of two

and such should consult Mr. Varley's memoirs in the "Transactions of the Society of Arts," vols. *xlvi.*, *xlix.*, *l.*; some parts of which are cited by Mr. Quekett in his "Practical Treatise on the Microscope," Third Ed., pp. 166, 397, *et seq.*

* This multiplication by bulbels was described by Amici in 1827; but his observations seem to have been forgotten by Botanists, until the rediscovery of the fact by M. Montagne.

long and very delicate filaments with which they are furnished.—The exterior of the 'nucule' (A, B) is formed by five spirally-twisted tubes, that give it a very peculiar aspect ;

FIG. 112.

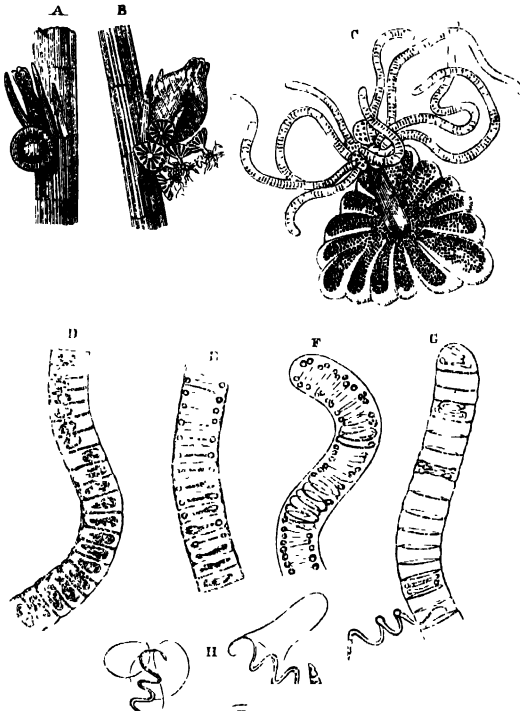

Antheridia of *Chara fragilis*:—A, antheridium or 'globule' developed at the base of pistillidium or 'nucule';—B, nucule enlarged, globule laid-open by the separation of its valves;—C, one of the groups of antheridial filaments, each composed of a linear series of cells, within every one of which an antherozoid is formed;—in D, E, and F, the successive stages of this formation are seen;—and at G is shown the escape of the mature antherozoids, H.

and these enclose a central sac containing protoplasm, oil, and starch-globules. At a certain period, the spirally-twisted tubes, which form a kind of crown around the summit, separate from each other, leaving a canal that leads-down to the central cell; and it is probable that through this canal the antherozoids make their way down, to perform the act of fertilization. Ultimately the nucule falls-off like a seed, and gives origin to a single new plant by a kind of germination.— The complete *specialization* of the Generative apparatus which we here observe (the organs of which it is composed being distinctly separated from the ordinary vegetating structure of the plant), as well as the complex structure of the organs themselves, mark-out this group, in spite of the simplicity of the rest of its structure, as belonging to a grade very much above that of the other families that have been treated-of in this chapter; but as scarcely any two Botanists agree upon the exact place which ought to be assigned to it, the convenience of associating it with other forms of vegetation of which the Microscopist especially takes cognizance, is a sufficient reason for so arranging it in a work like the present.

CHAPTER VII.

MICROSCOPIC STRUCTURE OF HIGHER CRYPTOGAMIA.

203. FROM those simple Protophytes, whose minuteness causes their entire fabrics to be fitting objects for Microscopic examination, we pass to those higher forms of Vegetable life, whose larger dimensions require that they should be analyzed (so to speak) by the examination of their separate parts. And in the present chapter, we shall bring under notice some of the principal points of interest to the Microscopist, which are presented by the *Cryptogamic* series; commencing with those simpler Algæ, which scarcely rank higher than some of the Protophytes already described; and ending with the Ferns and their allies, which closely abut upon the *Phanerogamia* or Flowering Plants. In ascending this series, we shall have to notice a *gradual differentiation* of organs; those set apart for Reproduction being in the first place separated from those appropriated to Nutrition (as we have already seen them to be in the Characæ); and the principal parts of the Nutritive apparatus, which are at first so blended together that no real distinction exists between root, stem, and leaf, being progressively evolved on types more and more peculiar to each respectively, and having their functions more and more limited to themselves alone. Hence we find a differentiation, not merely in the external form, but also in the intimate structure of organs; its degree bearing a close correspondence to the degree in which their functions are respectively *specialized* or limited to particular actions. Thus in the simple *Ulva* (Fig. 104), whatever may be the extent of the frond, every part has exactly the same structure, and performs the same actions, as every other part; living *for* and *by* itself alone. In *Batrachospermum* (Fig. 110), we have seen a definite arrangement of branches upon an axis of growth; and while the branches are formed of simple necklace-like rows of rounded cells, the cells of the stem are elongated and adhere to one another by flattened ends. This kind of differentiation is seen to be carried

to a still greater extent in *Mesogloia* (Fig. 113); a plant which may be considered as one of the connecting links between such Protophytes as *Batrachospermeæ*—which it resembles in general plan of structure,—and the Fucoid Algæ, which it resembles in fructification.

FIG 113.

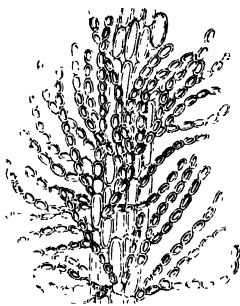
*Mesogloia vermicular*

204. When we pass to the higher Sea-weeds, such as the common *Fucus* and *Laminaria*, we observe a certain foreshadowing of the distinction between root, stem, and leaf; but this distinction is but very imperfectly carried-out, the root-like and stem-like portions serving for little else than the mechanical attachment of the leaf-like part of the plant, and each still absorbing and assimilating its own nutriment, so that no transmission of fluid takes-place from one portion of the fabric to another. Hence we find that there is not yet any departure from the simple *cellular* type of structure; the only modification being, that the several layers of cells, where many exist, are of different sizes and shapes, the texture being usually closer on the exterior and looser within; and that the texture of the stem and roots is denser than that of the expanded fronds. This simple cellular type of structure is maintained through all but the highest Cryptogamia; for it is not until we come to the Mosses, that the differentiation of stem, root, and leaf is established; and even in these it is not so fully carried-out, as to require a provision for the free transmission of fluid from one part to another; whilst the scale of their fabrics is not such as to render it necessary that their softer parts should be supported by a tissue of peculiar density. But in the group of Ferns, which, notwithstanding their complete adhesion to the Cryptogamic type of Reproduction, have the general form of the higher plants, and even attain the size and bearing of trees, we find the leaves separated from the roots by the intervention of a stem; and in this stem, as also in the leaf-stalks prolonged from it, we find, interposed in the midst of the cellular tissue which forms their principal substance, two new forms of structure,—namely, *woody fibre* which serves to give strength and support to the stem and

to the organs it bears, and *ducts* through which the liquid absorbed by the roots may be readily conveyed to the leaves.

205. The group of *Melanospermous* or olive-green Sea-weeds, which, in the family *Fucaceæ*, exhibits the highest type of Algal structure, presents us with the lowest in the family *Ectocarpaceæ*; which, notwithstanding, contains some of the most elegant and delicate structures that are anywhere to be found in the group, the full beauty of which can only be discerned by the microscope. Such is the case, for example,

with the *Sphaecelaria*, a small and delicate sea-weed, which is very commonly found parasitic upon larger Algæ, either near low-water-mark, or altogether submerged; its general form being remarkably characterized by a symmetry that extends also to the individual branches (Fig. 114), the ends of which, however, have a decayed look, that seems to have suggested the name of the genus (from the Greek *σφακελος*, gangrene).—The study of the higher and larger members of this group, has recently come to present a new and very attractive source of interest to the Microscopist, in consequence of the discovery of the truly-sexual nature of their fructification; and we shall take that of a common species of *Fucus* as the type of that of the order generally. The 'receptacles' which are borne at the extremities of the fronds, here contain both 'sperm-cells' and 'germ-cells'; in some other species, however, they are disposed in different receptacles on the same plant; whilst in the commonest of all, *F. vesiculosus* (bladder-wrack), they are limited to different individuals.* When a section is

FIG. 114.



Terminal portion of branch of
Sphaecelaria cirrhosa.

* It was at first stated by MM. Thuret and Decaisne, that this species was sometimes dioecious, sometimes hermaphrodite; but they now consider the hermaphrodite form to be a distinct species, the *F. platycarpus* described above.

made through one of the flattened receptacles of *F. platycarpus*, its interior is seen to be a nearly globular cavity (Fig. 115),

FIG. 115.

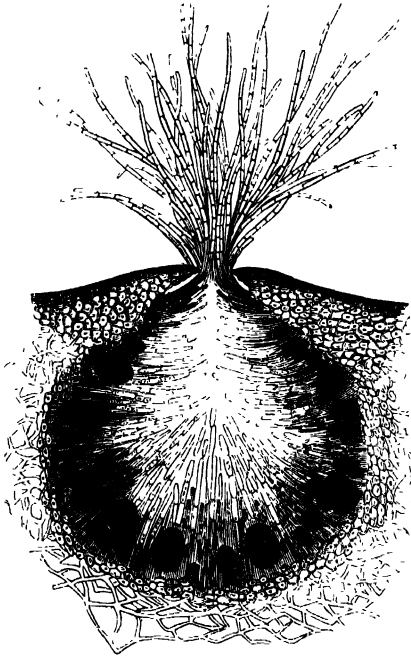

Vertical section of receptacle of *Fucus platycarpus*, lined with filaments, among which lie the antheridial cells, and the sporangia containing octospores.

lined with filamentous cells, some of which are greatly elongated, so as to project through the pore by which the cavity opens on the surface. Among these are to be distinguished, towards the period of their maturity, certain

filaments (Fig. 116, A) whose granular contents acquire an orange hue, and gradually shape themselves into oval bodies

FIG. 116.



Antheridia and antherozoids of *Fucus platycarpus*:—A, branching articulated hairs, detached from the walls of the receptacle, bearing antheridia in different stages of development; B, antherozoids, some of them free, others still included in their antheridial cells.

(B), each with an orange-coloured spot, and two long thread-like appendages, which, when discharged by the rupture of the containing cell, have for a time a rapid undulatory motion, whereby these antherozoids are diffused through the surrounding liquid. Lying amidst the filamentous mass, near the walls of the cavity, are seen (Fig. 115) numerous dark pear-shaped bodies, which are the *sporangia*, or parent-cells of the 'germ-cells.' Each of these sporangia gives origin, by duplicative subdivision, to a cluster of eight cells, which is thence known as an 'octospore;' and these are liberated from their envelopes, before the act of fertilization takes-place. This act consists in the swarming of the antherozoids over the surface of the germ-cells, to which they communicate a rotatory motion by the vibration of their own filaments; it takes-place within the receptacles in the hermaphrodite Fuci, so that the spores do not make their exit from the cavity until after they have been fecundated; but in the monœcious and diœcious species, each

kind of receptacle separately discharges its contents, which come into mutual contact on their exterior. The antheridial cells are usually ejected entire, but soon rupture, so as to give exit to their filaments; the sporangia of the female receptacles discharge their globular octospores within the receptacle; and these, soon after passing-forth, liberate their separate spores, which speedily meet with antherozoids and are fecundated by them. The spores, when fertilized, soon acquire a new and firmer envelope; and under favourable circumstances they speedily begin to develop themselves into new plants. The first change that is seen in them, is the projection and narrowing of one end into a kind of footstalk, by which the spore attaches itself, its form passing from the globular to the pear-shaped; a partition is speedily observable in its interior, its single cell being subdivided into two; and by a continuation of a like process of duplication, first a filament, and then a frondose expansion, is produced, which gradually evolves itself into the likeness of the parent-plant.—The whole of this process may be watched without difficulty, by obtaining specimens of *F. vesiculosus* at the period at which the fructification is shown to be mature, by the recent discharge of the contents of the receptacles in little gelatinous masses on their orifices; for if some of the spores, which have been set-free from the olive-green (female) receptacles, be placed in a drop of sea-water in a very shallow cell, and a small quantity of the mass of antherozoids set-free from the orange-yellow (male) receptacles, be mingled with the fluid, they will speedily be observed, with the aid of a magnifying power of 200 or 250 diameters, to go through the actions just described; and the subsequent processes of germination may be watched by means of the ‘growing-slide.’* The winter months, from December to March, are the most favourable for the observation of these phenomena; but where the Fuci abound, some individuals will usually be found in fructification at almost any period of the year.—Even in the *Fucacæ*, according to recent observations, a multiplication by zoospores, like that of the *Ulvacæ* (§ 195), still takes-place; these bodies being produced within certain of the cells that form the superficial layer of the frond, and swimming-about freely for a time after their emission, until they fix themselves and begin to grow. That they are to be considered *gemmæ*,

* If a cell be not employed, the drop should not be covered, unless some precaution be taken to keep the pressure of the thin-glass from the minute bodies beneath, whose movements it will otherwise unpece.

and not as generative products, appears certain from the fact that they will vegetate without the assistance of any other bodies; whereas the antherozoids of themselves never come to anything, and the octospores undergo no further changes, but decay away (as M. Thuret has experimentally ascertained), if not fecundated by the antherozoids.

206. Among the *Rhodosperræ*, or red Sea-weeds, also, we find various simple but most beautiful forms, which connect this group with the more elevated Protophytes, especially with the family *Chatophoracæ*; such delicate feathery or leaf-like fronds belong, for the most part to the family *Ceramiacæ*, some members of which are found upon every part of our coasts, attached either to rocks or stones, or to larger Algæ, and often themselves affording an attachment to Zoophytes and Bryozoa. They chiefly live in deeper water than the other sea-weeds; and their richest tints are only exhibited, when they grow under the shade of projecting rocks or of larger dark-coloured Algæ. Hence in growing them artificially in Aquaria, it is requisite to protect them from an excess of light; since otherwise they become unhealthy.—The nature of the fructification of the *Rhodosperræ* (or *Florideæ*) is less perfectly understood than that of the Fucoid Algæ. It is certain, however, that antheridia exist among them; these being developed in individuals that do not produce spores, and in pretty much the same situations. The products of these antheridia, however, do not exhibit the spontaneous motion of ordinary antherozoids. Of the spores there are two kinds, of which one set are probably 'gemmæ,' whilst the other are 'germ-cells;' but it is not yet determined to which of the two these characters respectively belong. The 'tetraspores,'—which are peculiarly characteristic of the group, being found in every one of its subdivisions,—are usually imbedded in the general substance of the frond, though they sometimes congregate in particular parts, or are restricted to a special branch. Each group (Fig. 117, B) seems to be evolved within one of the ordinary cells of the frond, which undergoes a duplicative subdivision; the four secondary cells, however, remain enclosed within their primary cell until the period of maturity, a new envelope, the 'perispore,' being formed around them. In the *Corallines*, which are sea-weeds whose tissue is consolidated by calcareous deposit, the tetraspores are included within hollow conceptacles; but generally speaking, it is the simple spores only which are thus specially protected. These are never scattered through the frond, like the tetraspores; and are commonly

developed within a *ceramidium*, which is an urn-shaped case, furnished with a pore at its summit, and containing a tuft of

FIG. 117.

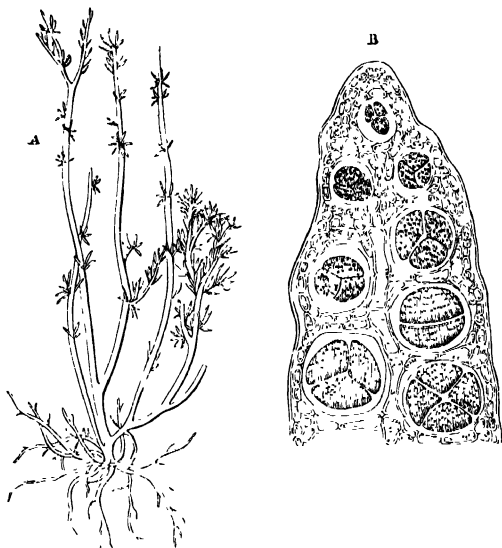

Arrangement of tetraspores in *Carpodaulon mediterraneum* —A, entire plant; n, longitudinal section of branch —(N.B. Where only three tetraspores are seen, it is merely because the fourth did not happen to be so placed as to be seen at the same view.)

pear-shaped spores arising from the base of its cavity. The resemblance of these bodies in position to the 'octospores' of Fuci, would seem to justify the conclusion that *they* are the true generative spores, whilst the tetraspores are gemmæ, as Harvey and Thwaites consider them; but a different view is taken by Decaisne, Agardh, and other eminent Algologists, who regard the tetraspores as the true generative spores, and consider the simple spores to be gemmæ. It is, therefore, a point of much interest to determine by careful observation and experiment which is the right view; and Microscopists

who have the opportunity of studying these plants, either in their native haunts, or in artificial Aquaria, can scarcely apply themselves to a better subject of investigation.

207. The class of *Lichens*, which consists of plants that closely correspond with *Algæ* in simplicity of organisation, but differ from them widely in habit, does not present so many objects of attractive interest to the Microscopist; and the peculiar density which usually characterizes their structure, renders a minute examination of it more than ordinarily difficult. Lichens are commonly found growing upon the trunks or branches of trees, upon rocks or stones, upon hard earth, or in other situations in which they are sparingly supplied with moisture, but are freely exposed to light and air. In the simpler forms of this group, the primordial cell gives origin, by the ordinary process of subdivision, to a single layer of cells, which may spread itself over the surface to which it is attached, in a more or less circular form; and one or more additional layers being afterwards developed upon its free surface, a *thallus* is formed, which has no very defined limit, and which, in consequence of the very slight adhesion of its component cells, is said to be 'pulverulent.' Sometimes, however, the cells of the thallus are rather arranged in the form of filaments, which penetrate the superficial layers of the bark whereon such Lichens grow, and which are sometimes also so interwoven at the outer surface, as to form a sort of cuticle. Interposed among the ordinary cells of the thallus, we very commonly find certain green globular cells, arranged in single bead-like filaments; these, which are termed *gonidia*, being found to be capable of reproducing the plant when detached, must be considered as *gemmæ*. In the higher tribes of Lichens, we find the interlacing filaments forming a tough cortical envelope to both surfaces; whilst in the interior of the firm 'crustaceous' thallus, the gonidial cells are found in regular layers. Sometimes these increase in particular spots, and make their way through the upper cortical layer, so as to appear on the surface as little masses of dust, which are called *soredia*.— Besides these, Lichens contain proper Generative organs, by which a true sexual reproduction seems to be effected. In addition to the 'fructification' which is commonly recognized by its projection from the surface of the thallus, the researches of M. Tulasne have detected a set of peculiar organs of much smaller size, not unlike the male receptacles of *Fuci* (§ 205), to which he has given the appellation of *spermogonia*. From the

exterior of the cellular filaments which line these cavities, a vast number of minute oval bodies termed *spermatia* are budded-off, which, when mature, escape in great numbers from the orifices of the spermogonia. They differ from ordinary antherozoids in being destitute of any power of spontaneous movement; but in this respect they are paralleled by the spermatoid bodies of the *Florideæ* (§ 206). As their participation in the production of fertile spores has not yet been demonstrated, we cannot yet indubitably assign to them the character of 'sperm-cells;' although various considerations concur to render their possession of this attribute highly probable. The female portion of the generative apparatus, though sometimes dispersed through the thallus, is usually collected into special aggregations, which form projections of various shapes; these, although they have received a variety of designations according to their particular conformation, may all be included under the general term *apothecia*. When divided by a vertical section, these bodies at their maturity are found to contain a number of *asci* or spore-cases, arranged vertically in the midst of straight elongated cells or filaments, which are termed *paraphyses*. Each of the *asci* contains a definite number of spores (usually eight, but always a multiple of two), which are projected from the apothecia with some force, the emission being kept-up continuously for some time; this discharge seems to be due to the different effect of moisture upon the different layers of the apothecium. When and how the act of fecundation is accomplished, is a matter still hidden in obscurity; and the problem is one which, owing to the difficulties arising out of the dense structure of the organs, will only be resolved by a combination of sagacity, manipulative skill, and perseverance, on the part of Microscopic observers who may devote themselves to the study.

208. In the simplest forms of *Fungi*, we again return to the lowest type of Vegetable existence, namely, the single cell; and such, if perfect plants, would properly take rank among the lowest Protophytes. But there is good reason for regarding many—perhaps all—of those which *seem* most simple, as the imperfectly-developed states of other Plants, which, if they attained their full evolution, would present a much more complex structure. This is the case, for example, with the *Torula cerevisiæ* or Yeast-plant, which so abounds in Yeast, that this substance may be said to be almost entirely made-up of it. When a small quantity of yeast is placed under the Microscope, and is magnified 300 or 400 diameters,

it is found to be full of globules, which are clearly cells; and these cells vegetate, when placed in a fermentible fluid containing some form of albuminous matter in addition to sugar, in the manner represented in Fig. 118. Each cell puts-

FIG. 118.

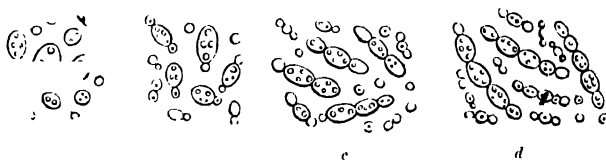

Torula Cerevisia, or Yeast-Plant, as developed during the process of fermentation.—*a, b, c, d*, successive stages of Cell-multiplication.

forth one or two projections, which seem to be young cells developed as buds or offsets from their predecessors; these, in the course of a short time, become complete cells, and again perform the same process; and in this manner the single cells of yeast develop themselves, in the course of a few hours, into rows of four, five, or six, which remain in continuity with each other whilst the plant is still growing, but which separate if the fermenting process be checked, and return to the isolated condition of those which originally constituted the yeast. Thus it is, that the quantity of yeast first introduced into the fermentible fluid, is multiplied six times or more, during the changes in which it takes part. The full development of the Plant, however, and the evolution of its apparatus of fructification, only occur, when the fermenting process is allowed to go on without check; and it seems capable of producing a considerable variety of forms, whose precise relationship to each other has not yet been made clear. In fact with regard to the Fungi generally, it has been made apparent by recent observations, that different individuals of the very same species may not only develop themselves according to a great number of very dissimilar modes of growth, but that they may even bear very dissimilar types of fructification; and further, that even the same individual may put forth, at different periods of its life, those two kinds of fructification,—the *basidio-sporous*, in which the spores are developed by out-growth from free points (*basidia*), and the *theca-sporous*, in which they are developed in the interior of

cases (*thecæ* or *asci*, Fig. 125),—which had been previously considered as separately characterizing the two principal groups, into which the class is primarily divided.

209. Many of the simpler forms of Fungi are inhabitants of the interior of the bodies of other animals, and are only known as living in these situations. Among these may first be mentioned the *Sarcina ventriculi* (Fig. 119), which is most frequently found in the matters vomited by persons suffering under disorder of the stomach, but has also been met with

Fig. 119.

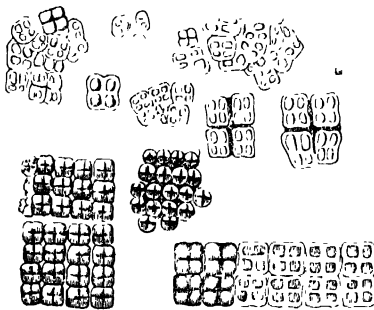

Sarcina ventriculi.

in other diseased parts of the body. The plant has been detected in the contents of the stomach, however, under circumstances which seem to indicate that it is not an uncommon tenant of that organ even in health, and that it may accumulate there to a considerable amount without producing any inconvenience; it seems probable, therefore, that its presence in disease is rather to be considered as favoured by the changed state of the fluids which the disease induces (either an acid or a fermentible state of the contents of the stomach having been generally found to exist in the cases in which the plant has been most abundant), than to be itself the occasion of the disease, as some have supposed. The *Sarcina* presents itself in the form of clusters of adherent cells arranged in squares, each square containing from 4 to 64, and the number of cells being obviously multiplied by duplicative subdivision in directions transverse to each other. In fact, its general mode of growth would indicate a near relationship to *Gonium*, one of the Volvocinæ, which presents itself in similar quadripartite aggregations; and many Botanists, looking to this circumstance, and to the residence of the plant in liquid, regard it as belonging to the group of Algæ. It agrees with the Fungi, however, in not living elsewhere than in liquids

containing organic matter; and there can be little doubt that, as no fructification has yet been seen in it, only its earlier and simpler condition is yet known to us. Its true place cannot be determined, until its whole life history shall have been followed-out.—There is a form of Fungous vegetation that is prone to develop itself within the living body, which is of great economic importance, as well as of scientific interest; this is the *Botrytis bassiana* (Fig. 120), a kind of 'mould,' the growth of which is the real source of a disease termed *Muscardine*, that sometimes carries-off Silk-worms in large numbers, just when they are about to enter the chrysalis state, to the great injury of their breeders. The sporules of this fungus, floating in the air, enter the breathing-pores which open into the tracheal system of the silk-worm (Chap. XVII.); they first develop themselves within the air-tubes, which are soon blocked-up by their growth; and they then extend themselves through the fatty mass beneath the skin, occasioning the destruction of this tissue, which is very important as a reservoir of nutriment to the animal, when it is about to pass into a state of complete inactivity. The disease invariably occasions the death of the silk-worm which it attacks; but it seldom shows itself externally until afterwards, when it rapidly shoots-forth from beneath the skin, especially at the junction of the rings of the body. Although it spontaneously attacks only the larva, yet it may be communicated by inoculation to the Chrysalis and the Moth, as well as to the worm; and it has been also observed to attack other Lepidopterous Insects. A careful investigation of the circumstances which favour the development of this disease, was made by Audouin, who first discovered its real nature; and he showed that its spread is favoured by the overcrowding of the worms in the breeding establishments, and particularly by the practice of throwing the bodies of such as die, into a heap in the immediate neighbourhood of the living worms; this heap speedily becomes covered with this kind of 'mould,' which finds upon it a most congenial soil; and it keeps-up a continual supply of sporules, which, being diffused through the atmosphere of the neighbourhood, are drawn into the breathing pores of individuals previously healthy. Wherever the precautions obviously suggested by the knowledge of the nature of the disease thus afforded by the Microscope, have been duly put in force, its extension has been kept within comparatively limited bounds. The plant presents itself (Fig. 120) under a considerable variety of forms; all of which, however, are of extremely

simple structure, consisting of elongated or rounded cells, connected in necklace-like filaments, very nearly as in the ordinary 'head moulds.'

FIG. 120.

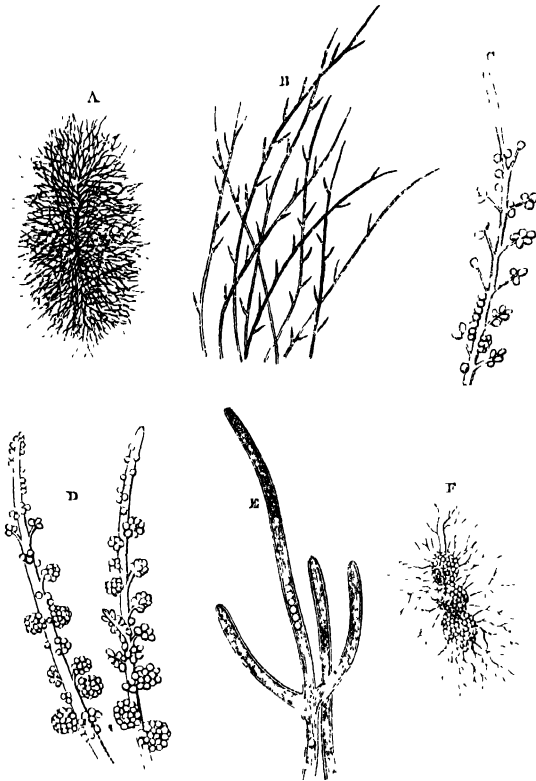

Botrytis bassiana —A, the fungus as it first appears at the orifices of the stigmata ; B, tubular filaments bearing short branches, as seen two days afterwards ; E, magnified view of the same ; C, D, appearance of filaments on the fourth and sixth days ; F, masses of mature spores falling off the branches, with filaments proceeding from them.

210. Again, it is not at all uncommon in the West Indies to see individuals of a species of *Polistes* (the representative of the Wasp of our own country) flying-about with plants of their own length projecting from some part of their surface, the germs of which have been probably introduced (as in the preceding case) through the breathing-pores at their sides, and have taken root in their substance, so as to produce a luxuriant vegetation. In time, however, this fungous growth spreads through the body, and destroys the life of the insect; it then seems to grow more rapidly, the decomposing tissue of the dead body being still more adapted than the living structure to afford it nutriment.—A similar growth of different species of the genus *Sphaeria* takes-place in the bodies of certain caterpillars in New Zealand, Australia, and China; and being thus completely pervaded by a dense substance, which, when dried, has almost the solidity of wood, these Caterpillars come to present the appearance of twigs, with long slender stalks that are formed by the projection of the fungus itself. The Chinese species is valued as a medicinal drug.—

121

The stomachs and intestines of many Worms and Insects are infested with Entophytic Fungi, which grow there with great luxuriance. In the accompanying illustrations (Figs. 121, 122) are shown some of the forms of the *Enterobryus*,* which has been found by Dr. Leidy to be so constantly present in the stomach of certain species of *Iulus* (gully-worm), that it is extremely rare to meet with individuals whose stomachs do *not* contain it. The *Enterobryus* originally

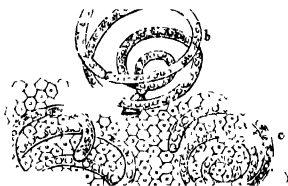

Growth of *Enterobryus spiralis* from mucous membrane of stomach of *Iulus* — *a*, epithelial-cells of mucous membrane; *b*, spiral thallus of *Enterobryus*; *c*, primary cells, *d*, secondary cell.

* This plant, also, has much affinity to Algae in its general type of structure, and is referred to that group by many Botanists, but the conditions of its growth, as in the case of *Sarcina*, seem rather to indicate its affinity to the Fungi; and until its proper fructification shall have been made-out, its true place in the scale must be considered as undetermined.

consists of a single long tubular cell, which sometimes grows in a spiral mode (Fig. 121), sometimes straight and tapering (Fig. 122, A); in its young state, the cell contains a transparent protoplasm, with granules and globules of various sizes; but in its more advanced condition, the tube of the filament is occupied by cells in various stages of development; these distend the terminal part of the cell (Fig. 122, B), and press

FIG. 122.

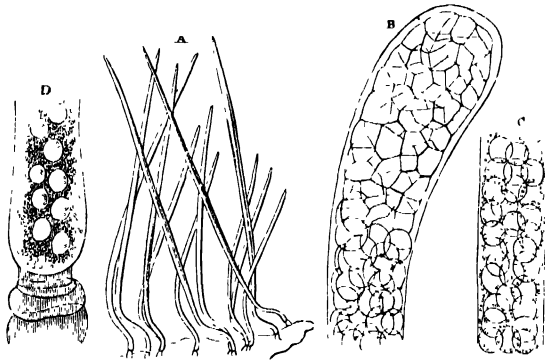

Structure of *Enterobryus*:—A, growth of *E. attenuatus*, from mucous membrane of stomach of *Passalus*; B, dilated extremity of primary cell of *E. elegans*, filled with secondary cells, which, near its termination, become mutually flattened by pressure, C, lower portion of the same filament, containing cells mingled with granules; D, base of the same filament, containing globules interspersed among granules.

so much against each other that their walls become flattened; whilst nearer the middle of the same filament (C), we find them retaining their rounded form, and merely lying in contact with each other; and at the base (D), they lie detached in the midst of the granular protoplasm. In *E. spiralis*, the primary cells (Fig. 121, b, c) very commonly have secondary and even ternary cells (d) developed at their extremities; but this is rarely seen in *E. attenuatus* (Fig. 122). It may be considered as next to certain that the tubular filaments rupture, when the contained cells have arrived at maturity, and give them exit; and that these cells are developed, under favourable circumstances, into tubular filaments like those from

which they sprang; but the process has not yet been thoroughly made-out. This is obviously not the true Generation of the plant, but is analogous to the development of zoospores in *Achlya* (§ 197). It is not a little curious, moreover, that the Entozoa or parasitic worms infesting the alimentary canal of these animals, should be frequently clothed *externally* with an abundant growth of such plants; in one instance Dr. Leidy found an *Ascaris* bearing twenty-three filaments of *Enterobryus* "which appeared to cause no inconvenience to the animal, as it moved and wriggled-about with all the ordinary activity of the species." The presence of this kind of vegetation seems to be related to the peculiar food of the animals in whose stomachs it is found; for Dr. Leidy could not discover a trace of these or of any other parasitic plants in the alimentary canal of the *carnivorous* Myriapods which he examined; whilst he met with a constant and most extraordinary profusion of vegetation (Fig. 123) in the stomach

FIG. 123.

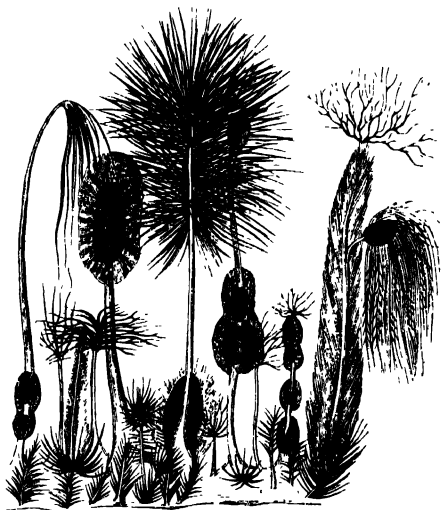

Fungoid Vegetation, clothing membrane of stomach of *Passulus*,
intermingled with brush-like hairs.

of a herbivorous beetle, the *Passalus corantus*, which lives, like the Luli, in stumps of old trees, and feeds as they do on decaying wood. Of this vegetation, some parts present themselves in tolerably definite forms, which have been described under various names; whilst other portions have the indefiniteness of imperfectly-developed organisms, and can scarcely be characterized in the present state of our knowledge of them. With regard to several forms, indeed, Dr. Leidy expresses a doubt whether they are parasitic plants, or whether they are outgrowths of the membrane itself.—There are various diseased conditions of the Human skin and mucous membranes, in which there is a combination of fungoid vegetation and morbid growth of the animal tissues; this is the case, for example, with the *Tinea farosa*, a disease of the scalp, in which yellow crusts are formed, that consist almost entirely of the mycelium, receptacles, and sporules of a fungus; and the like is true also of those white patches (*Aphthæ*) on the lining membrane of the mouth of children, which are known as *Thrush*. In these and similar cases, two opinions are entertained as to the relation of the fungi to the diseases in which they present themselves; some maintaining that their presence is the essential condition of these diseases, which originate in the introduction of the vegetable germs; and others considering their presence to be secondary to some morbid alteration of the parts wherein the fungi appear, which alteration favours their development. The first of these doctrines derives a strong support from the fact, that the diseases in question may be communicated to healthy individuals, through the introduction of the germs of the fungi by inoculation; whilst the second is rather consistent with general analogy, and especially with what is known of the conditions under which the various kinds of fungoid ‘blights’ develop themselves in or upon growing Plants (§ 212.)

211. There are scarcely any Microscopic objects more beautiful, than some of those forms of ‘mould’ or ‘mildew,’ which are so commonly found growing upon the surface of jams and other preserves; especially when they are viewed with a low magnifying power, by reflected light. For they present themselves as a forest of stems and branches, of extremely varied and elegant forms (Fig. 124), loaded with fruit of singular delicacy of conformation, all glistening brightly on a dark ground. In removing a portion of the ‘mould’ from the surface whereon it grows, for the purpose of microscopic examination, it is desirable to disturb it no more than can be

helped, in order that it may be seen as nearly as possible in its natural condition; and it is therefore preferable to take-up a portion of the membrane-like substance whereon it usually rests, which is, in fact, a *mycelium* composed of interlacing filaments of the *vegetative* part of the plant, the stems and branches being its *reproductive* portion (§ 213). The universality of the appearance of these simple forms of Fungi upon all spots favourable to their development, has given rise to the belief that they are spontaneously produced by decaying substances; but there is no occasion for this mode of accounting for it; since the extraordinary means adopted by Nature for the production and diffusion of the germs of these plants, adequately suffices to explain the facts of the case.

The number of sporules which any one Fungus may develop, is almost incalculable; a single individual of the puff-ball tribe has been computed to send forth no fewer than ten millions. And their minuteness is such, that they are scattered through the air in the condition of the finest possible dust; so that it is difficult to conceive of a place from which they should be excluded. This mode of explanation has received further confirmation from the facts recently ascertained, in regard to the great number of forms under which a single germ may develop itself; the particular form being determined, it seems likely, by the soil whereon each germ happens to grow. Hence we are not obliged to suppose that distinct germs are floating-about in the atmosphere, for all the forms of fungous vegetation which appear to be of different species, and which are only found in particular situations,—the *Puccinia roseæ*, for example, only upon rose-bushes, *Isaria felina* only upon the dung of cats deposited in humid and obscure situations, and *Onygena erigua* upon the hoofs of dead horses;—but are warranted in believing that the real variety of germs is comparatively small, and that the facts just stated,

FIG. 124.

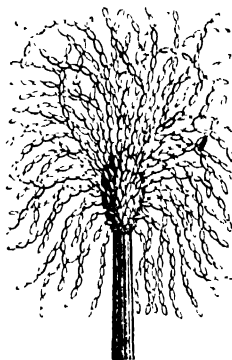
*Stygnus caput-medusæ.*

with others of the same order, only indicate the modifying influence of the circumstances under which they are developed.

212. The parasitic Fungi which infest some of the Vegetables most important to Man, as furnishing his staple articles of food, constitute a group of special interest to the Microscopist; of which a few of the chief examples may here be noticed. The *mildew*, which is often found attacking the straw of Wheat, shows itself externally in the form of circular clusters of pear-shaped spore-cases (Fig. 125), each containing

FIG. 125.

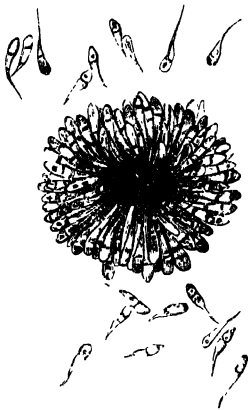

Puccinia graminis.

two compartments filled with sporules; these (constituting the *Puccinia graminis*) arise from a filamentous tissue constituting the *mycelium*, the threads of which interweave themselves with the tissue of the straw; and they generally make their way to the surface through the 'stomata' or breathing-pores of its epidermis. The *rust*, which makes its appearance on the leaves and chaff-scales of Wheat, has a fructification that seems essentially distinct from that just described, consisting of oval spore-cases, that grow without any regularity of arrangement from the threads of the *mycelium*; and hence it has been considered to

belong to a different genus and species, *Uredo rubigo*. But from the observations of Prof. Heuslow, it seems certain that the 'rust' is only an earlier form of the 'mildew,' the one form being capable of development into the other, and the fructification characteristic of the two supposed genera having been evolved on one and the same individual. Another reputed species of *Uredo* (the *U. segetum*) it is, which, when it attacks the flower of the wheat, reducing the ears to black masses of sooty powder, is known as 'smut' or 'dust-brand.' The corn-grains are entirely replaced by aggregations of spores; and these being of ex-

treme minuteness, they are very easily and very extensively diffused. The 'bunt' or 'stinking rust' is another species of *Uredo* (the *U. foetida*), which is chiefly distinguished by its disgusting odour.—The prevalence of these 'blights' to any considerable extent, seems generally traceable to some seasonal influences unfavourable to the healthy development of the wheat-plant; but they often make their appearance in particular localities, through careless cultivation, or want of due precaution in the selection of seed. It may be considered as certain that an admixture of the spores of any of these fungi with the grains, will endanger the plants raised from them; but it is equally certain that the fungi have little tendency to develop themselves in plants that are vegetating with perfect healthfulness. The wide prevalence of such blights in bad seasons is not difficult to account-for, if it be true (as the observations of Mr. John Marshall, a few years since, rendered probable) that there are really *very few* wheat-grains, near the points of which one or two sporules of Fungi may not be found, entangled among their minute hairs; and it may be fairly surmised that these sporules remain dormant, unless an unfavourable season should favour their development, by inducing an unhealthy condition of the wheat-plant.—The same general doctrine probably applies to the *Botrytis*, which, from 1847 to the present time, has had a large share in the production of the 'Potatoc-disease;' and to the *Oidium*, which has a like relation to the 'Vine-disease' that has been extending itself for some years past through the south of Europe. There seems no doubt that, in the fully-developed disease, the Fungus is always present; and that its growth and multiplication have a large share in the increase and extension of the disorder, just as the growth of the Yeast-plant excites and accelerates fermentation, and its reproduction enables this action to be indefinitely extended through its instrumentality. But just as the Yeast-plant will not vegetate save in a fermentable fluid,—that is, in a solution which, in addition to sugar, contains some decomposable albuminous matter,—so does it seem probable, on a consideration of all the phenomena of the Potatoc- and Vine-diseases, that neither the *Botrytis* of the one, nor the *Oidium* of the other will vegetate in perfectly healthy plants; but that a disordered condition, induced either by forcing and therefore unnatural systems of cultivation, or by unfavourable seasons, or by a combination of both, is necessary as a 'predisposing' condition.

213. In those lower forms of this class to which our notice of it has hitherto been chiefly restricted, there is not any very complete separation between its Nutritive or vegetative, and its Reproductive portions; every cell, as in the simplest Protophytes, being equally concerned in both. But such a separation makes itself apparent in the higher; and this in a very curious mode. For the ostensible Fungi of almost every description (Fig. 126) consist, in fact, of nothing else than

FIG. 126.

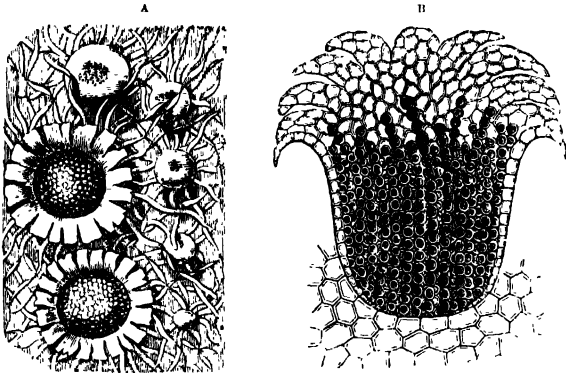

Aecidium tussilaginis:—A, portion of the plant magnified, B, section of one of the conceptacles with its spores.

the organs of *fructification*; the nutritive apparatus of these plants being composed of an indefinite *mycelium*, which is a filamentous expansion (Fig. 127), composed of elongated

FIG. 127.



Clavaria crispula:—a, portion of the mycelium magnified.

branching cells (*a*), interlacing amongst each other, but having no intimate connection; and this 'mycelium' has such an indefiniteness of form, and varies so little in the different tribes of Fungi, that no determination of species, genus, or even family, could be certainly made from it alone.—The recent observations of Tulasne render it probable that a true sexual generation exists among the Fungi; since he has ascertained that the presence of bodies resembling the *spermatia* of Lichens (§ 207) may be regarded as universal in the organs of fructification, at an early period of their development. These are budded-off (so to speak) from ramifying filaments, which are sometimes developed in the midst of those that bear the spores, and are sometimes found on other parts of the plant, being occasionally included in distinct conceptacles or *spermogonia*, as in Lichens. The whole history of the development of the Fungi, and the question of the relationship of its different forms to each other, is one that most urgently calls for re-examination at the present time, under the guidance of our recently-acquired knowledge, and with the assistance of improved instruments of Microscopic investigation; and whilst there is a wide field for the labours of those who possess only instruments of very moderate capacity, there are several questions which can only be worked-out by means of the highest powers and the most careful appliances which the practised Microscopist can bring to bear upon them.

214. The little group of *Hepaticæ* or 'Liverworts,' which is intermediate between Lichens and Mosses,—rather agreeing with the former in its general mode of growth, whilst approaching the latter in its fructification,—presents numerous objects of great interest to the Microscopist; and no species is richer in these, than the very common *Marchantia polymorpha*, which may often be found growing between the paving-stones of damp court-yards, but which particularly luxuriates in the neighbourhood of springs or waterfalls, where its lobed fronds are found covering extensive surfaces of moist rock or soil, adhering by the radical (root) filaments which arise from their lower surface. At the period of fructification, these fronds send-up stalks, which carry at their summits either round shield-like disks, or radiating bodies that bear some resemblance to a wheel without its tire (Fig. 128); the former carry the male organs or antheridia, and the latter, at an early period, the female organs or archegonia, which

afterwards give place to the *sporangia* or spore-cases.* But besides these, the frond usually bears upon its surface (as

FIG. 128.



Frond of *Marchantia polymorpha*, with gemmiparous conceptacles, and lobed receptacles bearing pistillidia.

shown in Fig. 129) a number of little open basket-shaped 'conceptacles,' whose nature and purpose will be presently explained.—The green surface of the frond of this Liverwort is seen under a low magnifying power to be divided into minute diamond-shaped spaces (Fig. 129, A, *a, a*) bounded by raised bands (*c, c*); every one of these spaces

has in its centre a curious brownish-coloured body (*b, b*), with an opening in its middle, which allows a few small green cells to be seen through it. When a thin vertical section is made of the frond (B), it is seen that each of the lozenge-shaped divisions of its surface corresponds with an air-chamber in its interior; which is bounded below by a floor (*a, a*) of closely-set cells (from whose under surface the radical filaments arise), at the sides by walls (*c, c*) of similar solid parenchyma, the projection of whose summits forms the raised bands on the surface, and above by a cuticle (*b, b*) formed of a single layer of cells; whilst its interior is occupied by a very loosely-arranged parenchyma, composed of branching rows of cells (*f, f'*) that seem to spring from the floor,—these cells being what are seen from above, when the observer looks-down through the central aperture just mentioned. If the vertical section should happen to traverse one of the peculiar bodies which occupies the centres of the divisions, it will bring into view a structure of remarkable complexity. Each of these *stomata* (as they are termed, from the Greek *στομα*, mouth) forms a sort of shaft (*g*), composed of four or five rings (like the 'courses' of

* In some species, the same shields bear both sets of organs; and in *Marchantia androgyna*, we find the upper surface of one half of the pelta developing antheridia, whilst the under surface of the under half bears archegonia.

bricks in a chimney) placed one upon the other (*h*), every ring being made-up of four or five cells; and the lowest of these rings (*i*) ap-

pears to regulate the aperture, by the contraction or expansion of the cells which compose it, and it is hence termed the 'obturator-ring.' In this manner, each of the air-chambers of the frond is brought into communication with the external atmosphere; the degree of that communication being regulated by the limitation of the aperture. We shall hereafter find (§ 245) that the leaves of the higher Plants contain intercellular spaces, which also communicate with the exterior by 'stomata;' but that the structure of these organs is far less complex in them, than it is in this humble Liverwort.

215. The basket-shaped 'conceptacles' which are borne upon the surface of the frond (Fig. 130, A), and which may often be found in all stages of development, are structures of singular beauty. They contain, when mature, a number of little green round or oblong disks, each composed of two or more layers of cells; and their wall is surmounted by a glistening fringe of 'teeth,' whose edges are themselves regularly fringed with minute outgrowths. This fringe is at first formed by the splitting-up of the epidermis,

FIG. 129.

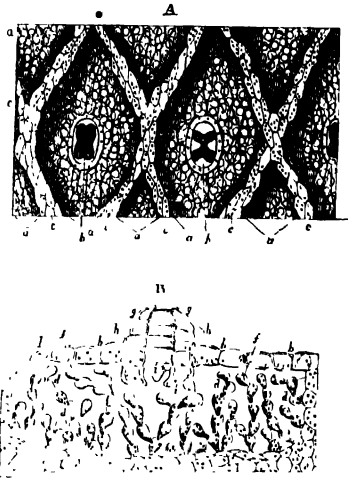

A, Portion of frond of *Marchantia polymorpha* seen from above; *a, a*, lozenge-shaped divisions; *b, b*, stomata seen in the centre of the lozenges; *c, c*, greenish bands separating the lozenges:—B, vertical section of the frond, showing *a, a* the dense layer of cellular tissue forming the floor of the cavity *d, d*; *b, b*, cuticular layer, forming its roof; *c, c*, its walls; *f, f*, loose cells in its interior; *g, g*, stoma divided perpendicularly; *h, h*, rings of cells forming its wall; *i, i*, cells forming the obturator-ring.

as seen at B, at the time when the conceptacle and its contents are first making their way above the surface. The little disks (sometimes termed 'bulbels,' from their analogy to the bulbels

FIG. 130.

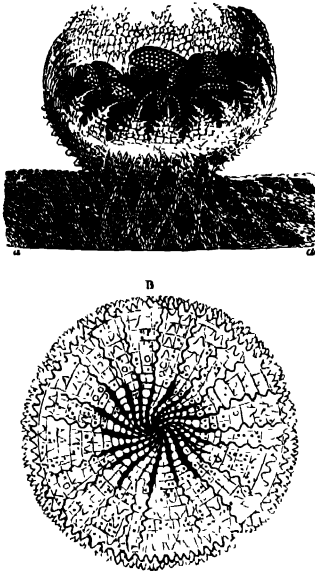

Gemmiparous conceptacles of *Marchantia polymorpha*.—A, conceptacle fully expanded, rising from the surface of the frond *a a*, and containing disks already detached;—B, first appearance of conceptacle on the surface of the frond, showing the formation of its fringe by the splitting of the cuticle.

or detached buds of Flowering Plants) are at first evolved as single globular cells, supported upon other cells which form their footstalks; these single cells gradually undergo multiplication by duplicative subdivision, until they evolve themselves into the disks; and these disks, when mature, spontaneously detach themselves from their footstalks, and lie free within the cavity of the conceptacle. Most commonly they are at last washed-out by rain, and are thus carried to different parts of the neighbouring soil, on which they grow very rapidly when well supplied with moisture; sometimes, however, they may be found growing whilst still contained within the conceptacles, forming natural grafts (so to speak) upon the stock from which they have been developed and detached; and many of

the irregular lobes which the frond of the *Marchantia* puts forth, seem to have this origin.—When this plant vegetates in damp shady situations, which are favourable to the nutritive processes, it does not readily produce the true fructification, which is to be looked-for rather in plants growing in

more exposed places. Each of the stalked peltate (shield-like) disks contains a number of flask-shaped cavities opening upon its upper surface, which are brought into view by a vertical section; and in each of these cavities is lodged an 'antheridium,' composed of a mass of 'sperm-cells,' within which are developed 'antherozoids' like those of *Chara* (§ 202), surmounted by a long neck that projects through the mouth of the flask-shaped cavity. The wheel-like receptacles (Fig. 128) on the other hand, bear on their under surface, at an early stage, concealed between membranes that connect the origins of the lobes with one another, a set of 'archegonia,' shaped like flasks with elongated necks (Fig. 131); each of these has in its interior

a 'germ-cell,' to which a canal leads-down from the extremity of the neck; and there is every reason to believe that, as in Ferns, the germ-cell is fertilized by the penetration of the antheridia through this canal, until they reach it. Instead, however, of at once evolving itself into a new plant resembling its parent, the fertilized germ-cell, or embryo-cell, develops itself into a mass of cells inclosed

within a capsule, which is termed a 'sporangium;' and thus the mature receptacle, in place of archegonia, bears capsules or sporangia, which finally burst-open, and discharge their contents. These contents consist of 'spores,' which are isolated cells, enclosed in firm yellow envelopes; and of 'elaters,' which are ovoidal cells, each containing a double spiral fibre coiled-up in its interior. This fibre is so elastic, that, when the surrounding pressure is withdrawn by the bursting of the sporangium, the spires extend themselves (Fig. 132), tearing-apart the cell-membrane; and they do this suddenly, so as to jerk-forth the spores which may be adherent to their coils, and thus to assist in their dispersion. The spores, when subjected to moisture, with a moderate amount of light and warmth, develop themselves into little collections of cells,

Fig. 131.

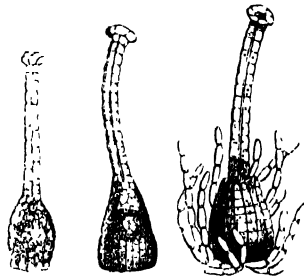

Archegonia of *Marchantia polynorpha*, in successive stages of development.

which gradually assume the form of a flattened frond; and thus the species is very extensively multiplied, every one of the mass of spores, which is the product of a single germ-cell, being capable of giving origin to an independent individual.

FIG. 132.



Elater and Spores
of *Marchantia*.

for instead of being small and polygonal, they are large and elongated (Fig. 133); they contain spiral fibres loosely coiled in their interior; and their membranous walls have large rounded apertures, by which their cavities freely communicate with one another, as is sometimes curiously

216. The tribe of *Mosses* is as remarkable from the delicacy and minuteness of all the plants composing it, as other orders of the Vegetable Kingdom are for the majesty of their forms, the richness of their foliage, or the splendour of their blossoms. There is not one of this little tribe, whose external organs do not serve as beautiful objects, when viewed with low powers of the Microscope; while their more concealed wonders are admirably fitted for the detailed scrutiny of the practised observer—The Mosses always possess a distinct axis of growth, commonly more or less erect, on which the minute and delicately-formed leaves are arranged with great regularity. The stem shows some indication of the separation of a *cortical* or bark-like portion, from the *medullary* or pith-like, by the intervention of a circle of bundles of elongated cells, which seem to prefigure the woody portion of the stem of higher plants, and from which prolongations pass into the leaves, so as to afford them a sort of midrib. The leaf usually consists of either a single or a double layer of cells, having flattened sides by which they adhere one to another; they rarely present any distinct epidermic layer; but such a layer, perforated by stomata of simple structure, is commonly found on the *setæ* or bristle-like footstalks bearing the fructification, and sometimes on the midribs of the leaves. The leaf-cells of the *Sphagnum* (bog-moss) exhibit a very curious departure from the ordinary type;

evidenced by the passage of Wheel-Animalcules, that make their habitation in these chambers. Between these coarsely spiral cells, are some thick-walled narrow elongated cells, which give to the leaf its firmness; these, in the very young leaf (as Mr. Huxley has pointed-out) do not differ much in appearance from the others; the peculiarities of both being evolved by a gradual process of 'differentiation.'—The chief interest of the Mosses, however, to the Microscopist, lies in their fructification; which recent discoveries have invested with a new character. What has been commonly regarded in that light, namely, the 'capsule' or 'urn,' borne at the top of a long footstalk, which springs from the centre of a cluster of leaves (Fig. 134, A), is not the real fructification, but its product; for Mosses, like Liverworts, possess both antheridia and pistillidia, although these are by no means conspicuous. These organs are sometimes found in the same envelope (or perigone), sometimes on different parts of the same plant, sometimes only on different individuals; but in either case, they are usually situated close to the axis, among the bases of the leaves. The antheridia are globular, oval, or elongated bodies (Fig. 135, A) composed of aggregations of cells, of which the exterior form a sort of capsule, whilst the interior are 'sperm-cells,' each of which, as it comes to maturity, develops within itself an 'antherozoid' (B, C, D); and the antherozoids, set free by the rupture of the cells within which they are formed, make their escape by a passage that opens for them at the summit of the antheridium. The antheridia are generally surrounded by a cluster of hair-like filaments, composed of cells joined together (Fig. 134, A), and called

FIG. 133.

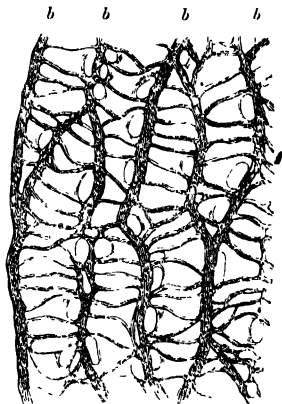

Portion of the leaf of *Sphagnum*; showing the large cells, *a, a, a*, with spiral fibres and communicating apertures, and the intervening bands, *b, b, b*, composed of small elongated cells.

'paraphyses.' The archegonia bear a general resemblance to those of *Marchantia* (Fig. 131); and there is every reason to

FIG. 134.

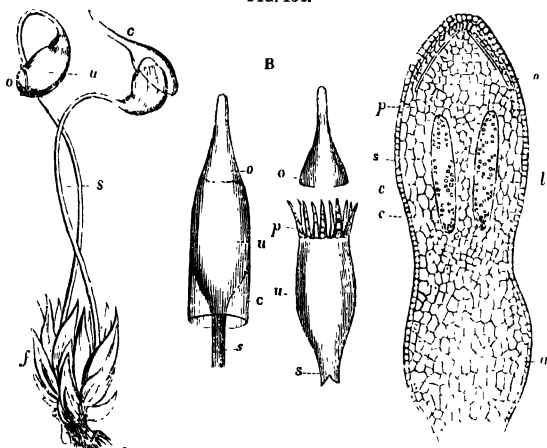

Structure of Mosses:—A, Plant of *Funaria hygrometrica*, showing *f* the leaves, *u* the urns supported upon the setae or footstalks *s*, closed by the operculum *o*, and covered by the calyptra *c*—B, urns of *Encalypta vulgaris*, one of them closed and covered with the calyptra, the other open; *u, u*, the urns; *o, o*, the opercula; *c*, calyptra; *p*, peristome; *s, s*, setae:—C, longitudinal section of very young urn of *Splachnum*; *a*, solid tissue forming the lower part of the capsule; *c*, columella; *l*, loculus or space around it for the development of the spores; *e*, epidermic layer of cells, thickened at the top to form the operculum *o*; *p*, two intermediate layers, from which the peristome will be formed; *s*, inner layer of cells forming the wall of the loculus.

believe that the fertilization of their contained germ-cells is accomplished in the manner already described; for antherozoids have been observed swimming about around the archegonia within their involucre,* and the evolution of capsules from archegonia has been ascertained not to take-place in those Mosses which bear the two sets of organs on separate

* The detection of the antherozoids *within* the canal of the archegonium, and upon the surface of the germ-cell, is a point well worthy of Microscopic research.

FIG. 135.

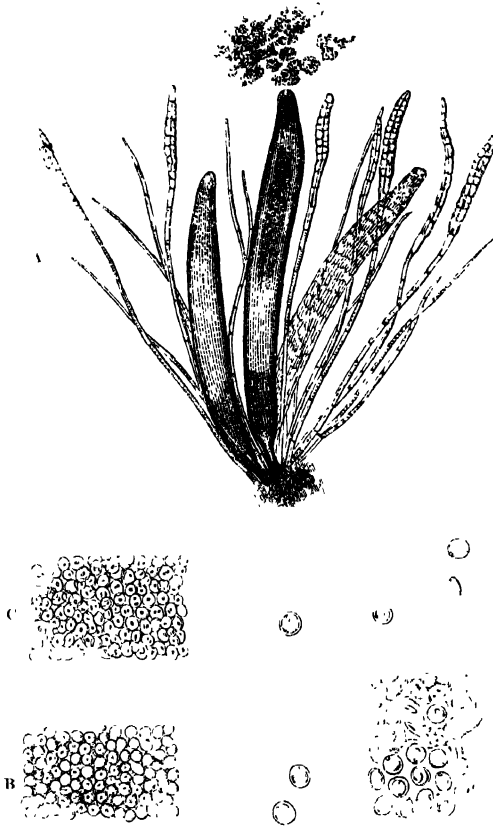

Antheridia and Antherozoids of *Polytrichum commune*:—A, group of antheridia, mingled with hairs and sterile filaments (paraphyses); of the three antheridia, the central one is in the act of discharging its contents; that on the left is not yet mature, while that on the right has already emptied itself, so that the cellular structure of its walls becomes apparent;—B, cellular contents of an antheridium, previously to the development of the antherozoids;—C, the same, showing the first appearance of the antherozoids;—D, the same, mature and discharging the antherozoids.

individuals, unless an antheridial plant be in the neighbourhood. The fertilized embryonal cell becomes gradually developed by cell-division into a conical body elevated upon a stalk; and this at length tears-across the walls of the flask-shaped archegonium by a circular fissure, carrying the higher part upwards as a *calyptra* or hood (Fig. 135, B, c) upon its summit, while the lower part remains to form a kind of collar round the base of the stalk.

217. The 'urns' or spore-capsules of Mosses, which are thus the immediate product of the Generative act, and which must really be considered as the offspring of the plants that bear them (although grafted-on to these, and drawing their nourishment from them), are closed at their summit by *opercula* or lids (Fig. 135, B, o, o), which fall-off when the

FIG. 136.

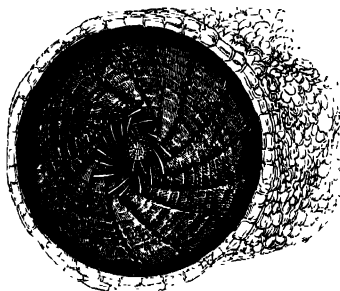

Mouth of capsule of *Funaria*, showing the Peristome *in situ*.

contents of the capsules are mature, so as to give them free exit; and the mouth thus laid-open is surrounded by a beautiful-toothed fringe, which is termed the *peristome*. This fringe, as seen in its original undisturbed position, is shown in Fig. 136; whilst in Figs. 137-139 are shown three different forms of it, spread-out

and detached, illustrating the varieties which it exhibits in different genera of Mosses,—varieties whose existence and readiness of recognition render them characters of extreme value to the systematic Botanist, whilst they furnish objects of great interest and beauty for the Microscopist. The peristome seems always to be originally double, one layer springing from the outer, and the other from the inner, of two layers of cells which may be distinguished in the immature capsule (Fig. 135, c, p); but frequently, at the time of maturity, one or other of these is wanting, and sometimes both are oblite-

rated, so that there is no peristome at all. The number of the 'teeth' is always a multiple of 4, varying from 4 to 64; sometimes they are prolonged into straight or twisted hairs. The spores are contained in the upper part of the capsule, where they are clustered round a central pillar, which is termed the *columella*. In the young capsule, the whole mass is nearly solid (Fig. 135, c), the space (*l*) in which the spores are developed being very small; but this gradually augments, the walls becoming more condensed; and at the time of maturity, the interior of the capsule is almost entirely occupied by the spores, in the dispersion of which the peristome seems in some degree to answer the same purpose as the claters of *Hepaticæ*.

FIG. 137.

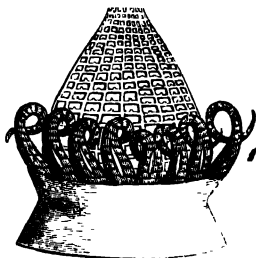

Double Peristome of *Fontinalis antipyretica*.

FIG. 138.

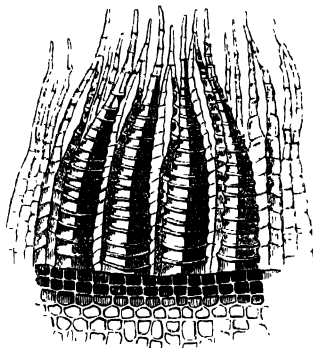

Double Peristome of *Bryum intermedium*.

FIG. 139.

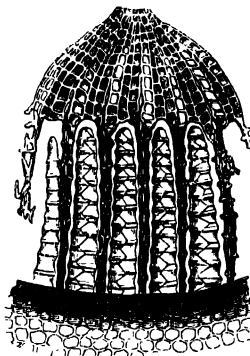

Double Peristome of *Cnecidium arcticum*.

The development of the spores into new plants, commences with the rupture of their outer walls, and a protru-

sion of their inner coats ; and from the projecting extremity new cells are put-forth by a process of outgrowth, which form a sort of confervoid filament (as in Fig. 145, c). At certain points of this filament, its component cells multiply by subdivision, so as to form rounded clusters, from every one of which an independent plant may arise ; so that several individuals may be evolved from a single spore. A numerous aggregation of spores may be developed, as we have seen, from a single germ-cell ; so that the immediate product of each act of fertilization does not consist (as in the higher Plants) of a single seed, that afterwards develops itself into a composite fabric, whence are put-forth a multitude of leaf-buds, every one of which is capable (under favourable circumstances) of evolving itself into a complete Plant ; but divides itself at once into a mass of isolated cells (spores), of which every one may be considered in the light of a bud or *gemma* of the simplest possible kind, and one of the first acts of which is to put-forth other buds, whereby the rapid extension of these plants is secured, although no separate individual ever attains more than a very limited size.

218. In the *Ferns* we have in many respects a near approximation to Flowering-plants ; but this approximation does not extend to their Reproductive apparatus, which is formed upon a type essentially the same as that of Mosses, but is evolved

at a very different period of life. As the component tissues of which their fabrics are composed, are essentially the same as those which will be described in the next chapter, it will not be requisite here to dwell upon them. The stem (where it exists) is for the most part made-up of cellular parenchyma, which is separated into a cortical and a medullary portion, by the interposition of a circular series of fibro-vascular bundles containing true woody tissue and ducts. These bundles form a kind of irregular net-

FIG. 140.

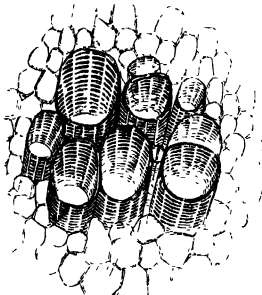

Oblique section of footstalk of *Fern-leaf*, showing bundle of scalariform ducts.

work, from which prolongations are given-off that pass into the leaf-stalks, and thence into the mid-rib and its lateral branches; and it is their peculiar arrangement in the leaf-stalks, which gives to the transverse section of these the figured marking commonly known as 'King Charles in the oak.' A thin section, especially if somewhat oblique (Fig. 140), displays extremely well the peculiar character of the ducts of the Fern; which are termed 'scalariform,' from the resemblance of the regular markings on their walls to the rungs of a ladder.—What is usually considered the 'fructification' of the Ferns, affords a most beautiful and readily-prepared class of opaque objects for the lowest powers of the Microscope; nothing more being necessary, than to lay a fragment of the frond that bears it on its under surface, upon the glass stage-plate, or to hold it in the stage-forceps, and to throw an adequate light upon it by the side-condenser. It usually presents itself in the form of isolated spots, termed *sori*, as in the common *Polypodium* (Fig. 141) and in the *Aspidium* (Fig. 143); but sometimes these 'sori' are elongated into bands, as



Leaflet of *Polypodium*,
with sori.

in the common *Scolopendrum* (Harts-tongue): and these bands may coalesce with each other, so as almost to cover the surface of the frond with a network, as in *Hæmionites* (Fig. 142); or they may form merely a single band along its borders, as in the common *Pteris* (brake-fern). The sori are sometimes naked on the under surface of the fronds; but they are frequently covered with a delicate membrane, termed the *indusium*, which may either form a sort of cap upon the summit of each sorus, as in *Aspidium* (Fig. 143), or a long fold, as in *Scolopendrum* and *Pteris*, or a sort of cup, as in *Deparia* (Fig. 144). Each of these sori, when sufficiently magnified, is found to be made-up of a multitude of capsules or *thecæ* (Figs. 143, 144), which are sometimes closely attached to the surface of the leaf, but

more commonly spring from it by a pedicel or foot-stalk. The wall of the capsule is composed of flattened cells, applied to each other by their edges; but there is generally one row of these, thicker and larger than the rest, which springs from the pedicel, and is continued over the summit of the capsule, so as to form a projecting ring, which is known as the *annulus*.

FIG. 142.

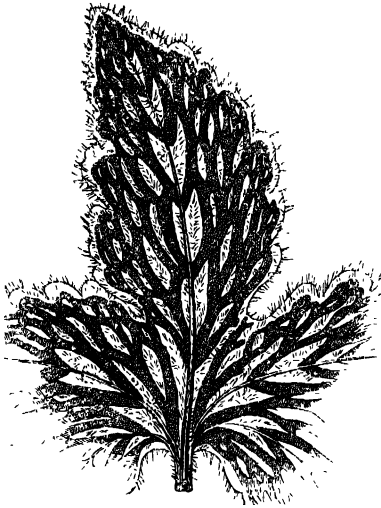

Portion of Frond of *Hæmonitis*, with sori.

This ring has an elasticity superior to that of all the rest of the capsular wall, causing it to split across, when mature, so that the contained spores may escape; and in many instances

carrying the two halves of the capsule widely apart from each other (Fig. 141), the fissure extending to such a depth as to separate them completely.—It will frequently happen, that specimens of Fern-fructification gathered for the Microscope, will be found to have all the capsules burst and the spores dispersed, whilst in others, less advanced, the capsules may all be closed: others, however, may often be met-with, in which some of the capsules are closed and others are open; and if these be watched with sufficient attention, the rupture of some of the thecæ and the dispersion of the spores may be observed to take-place, whilst the specimen is under observation in the field of the microscope. In sori whose capsules have all burst, the annuli connecting their two halves are the most conspicuous objects, looking, when a strong light is thrown upon them, like strongly-banded worms of a bright brown hue.

This is particularly the case in *Scolopendrum*, whose elongated sori are remarkably beautiful objects for the microscope in all

FIG. 143.

Sorus and indusium of *Aspidium*.

FIG. 144.

Sorus and cup-shaped indusium of
Deparia prolifera.

their stages; until quite mature, however, they need to be brought into view by turning-back the two indusial folds that cover them. The commonest Ferns, indeed, which are found in almost every hedge, furnish objects of no less beauty than those yielded by the rarest exotics; and it is in every respect a most valuable training to the young, to teach them how much there may be found to interest, when looked-for with intelligent eyes, even in the most familiar and therefore disregarded specimens of Nature's handiwork.

219. The spores (Fig. 145, A) set-free by the bursting of the thecae, usually have a somewhat angular form, and are invested by a yellowish or brownish outer coat, which is marked, very much in the manner of pollen-grains (Fig. 187), with points, streaks, ridges, or reticulations. When placed upon a damp surface, and exposed to a sufficiency of light and warmth, the spore begins to 'germinate,' the first indication of its vegetative activity being a slight enlargement, which is manifested in the rounding-off of its angles; this is followed by the putting-forth of a tubular prolongation (B, a) of the internal cell-wall, through an aperture in the outer spore-coat; and, by the absorption of moisture through this root-fibre, the inner cell is so distended, that it bursts the external unyielding integument, and soon begins to elongate itself in a direction opposite to that of the root-fibre. A production of new cells by subdivision then takes-place from its growing

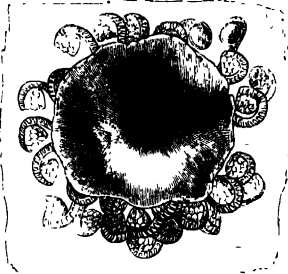
extremity; this at first proceeds in a single series, so as to form a kind of confervoid filament (c); but the multiplication of cells

FIG. 145.

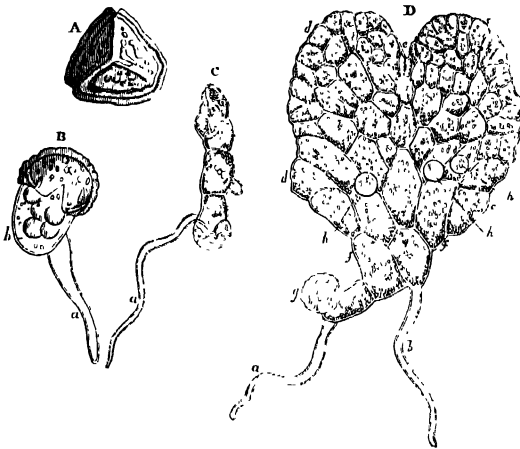

Development of Prothallium of *Pteris serrulata* —A, spore set free from the theca, —B, spore beginning to germinate, putting forth the tubular prolongation *a* from the principal cell *b*, *c*, first-formed linear series of cells, —D, prothallium taking the form of a leaf-like expansion; *a* first, and *b* second radical fibre, *c, d*, the two lobes, and *e* the indentation between them, *f, f*, first-formed part of the prothallium, *g*, external coat of the original spore; *h, h*, antheridia

by subdivision soon takes place transversely as well as longitudinally, so that a flattened leaf-like expansion (D) is produced, so closely resembling that of a young *Marchantia* as to be readily mistaken for it. This expansion, which is termed the *prothallium*, varies in its configuration in different species; but its essential structure always remains the same. From its under surface are developed, not merely the root-fibres (*a, b*) which serve to fix it in the soil, and at the same time to supply it with moisture, but also the antheridia and archegonia, which constitute the true representatives of the essential parts of the flower of higher Plants.—Some of the *antheridia* may be distinguished at an early period of the development of the prothallium (*h, h*); and at the time of its complete evolution these bodies are seen in considerable numbers, especially about

the origins of the root-fibres. Each has its origin in a peculiar protrusion that takes-place from one of the cells of the pro-

FIG. 146.

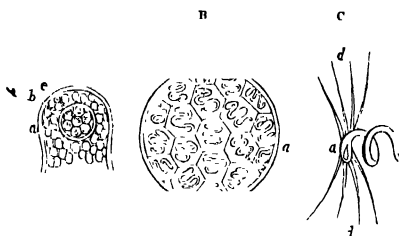

Development of the Antheridia and Antherozoids of *Pteris serrulata* - A, projection of one of the cells of the prothallium, showing the anthridial cell, *b*, with its sperm-cells, *c*, within the cavity of the original cell, *a*, - B, antheridium completely developed; *a*, wall of anthridial cell, *c*, sperm-cells, each enclosing an antherozoid, - C, one of the antherozoids more highly magnified, showing *a*, its large extremity, *b*, its small extremity, *d, d*, its cilia.

thallium (Fig. 146, A, *a*), this is at first entirely filled with chlorophyll-granules; but soon a peculiar free cell (*b*) is seen in its interior, filled with mucilage and colourless granules. This cell gradually becomes filled with another brood of young cells (*c*), and increases considerably in its dimensions, so as to fill the projection which incloses it; this part of the original cavity is now cut-off from that of the cell of which it was an offshoot, and the antheridium henceforth ranks as a distinct and independent organ. Each of the secondary cells (*b*) contained within its primary cell, is seen, as it approaches maturity, to contain a spirally-coiled filament; and when they have been set-free by the bursting of the antheridium, they themselves burst and give exit to their 'antherozoids' (*c*), which execute rapid movements of rotation on their axes, partly dependent on the six long cilia with which they are furnished.—The *archegonia* are fewer in number, and are found upon a different part of the prothallium. Each of them at its origin presents itself only as a slight elevation of the cellular layer of the prothallium, within which is a large intercellular space containing a peculiar cell (the 'germ-cell'), and opening externally by an orifice at the summit of the projection; but when fully developed (Fig. 147), it is composed of from ten to twelve cells built-up in layers of four cells each, one upon

another, so as to form a kind of chimney or shaft, having a central passage that leads-down to the cavity at its base, wherein the germ-cell is contained. Into this cavity the

FIG. 147.

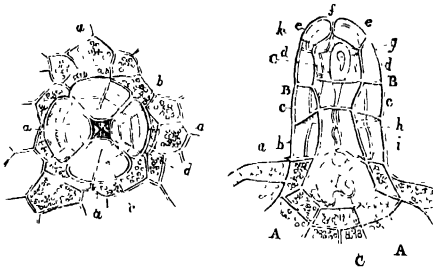

Archegonium of *Pteris serrulata* —A, as seen from above; a, a, a, cells surrounding the base of the cavity, o, c, d, successive layers of cells, the highest enclosing a quadrangular orifice —n, side-view, showing A, A, cavity containing the germ-cell; n, n, walls of the archegonium, made-up of the four layers of cells, b, c, d, e, and having an opening on the summit; c, c, antherozoids within the cavity; g, large extremity, h, thread-like portion; i, small extremity in contact with the germ-cell, and dilated.

antherozoids penetrate, so as to come into contact with the 'germ-cell;' and, by the softening of the membrane at its apex, they are even enabled to enter its cavity, within which a minute 'embryonic vesicle' was previously distinguishable. This embryonic vesicle, when fertilized by the antherozoids which move actively round it, becomes the primordial cell of a new plant, the development of which speedily commences.* By the usual process of duplicative subdivision

* See Hofmeister, in "Ann. of Nat. Hist.," 2nd Ser. Vol. xiv. p. 272 —The study of the development of the spores of Ferns, and of the act of fertilization and of its products, may be conveniently prosecuted as follows — Let a frond of a Fern, whose fructification is mature, be laid upon a piece of fine paper, with its spore-bearing surface downwards, in the course of a day or two, this paper will be found to be covered with a very fine brownish dust, which consists of the discharged spores. This must be carefully collected, and should be spread upon the surface of a smoothed fragment of porous sandstone; the stone being placed in a saucer, the bottom of which is covered with water, and a glass tumbler being inverted over it, the requisite supply of moisture is ensured, and the spores will germinate luxuriantly. Some of the prothallia soon advance beyond the rest; and at the time when the advanced ones have long ceased to produce antheridia, and bear abundance of archegonia, those which have remained behind in their growth are beginning to be covered with antheridia. If the crop be now kept with little moisture for

a globular homogeneous mass of cells is at first formed; but rudiments of special organs soon begin to make their appearance; the germ grows at the expense of the nutriment prepared for it by the prothallium; and it soon bursts-forth from the cavity of the archegonium, which organ in the meantime is becoming atrophied. In the very beginning of its development, the tendency is seen in the cells of one extremity to grow upwards, so as to evolve the stem and leaves, and in those of the other extremity to grow downwards, to form the root; and when these organs have been sufficiently developed to absorb and prepare the nutriment which the young plant requires, the prothallium, whose function as a 'nurse' is now discharged, decays away.

220. The little group of *Equisetaceæ* (Horsetails), which seem nearly allied to the Ferns in the type of their generative apparatus, though that of their vegetative portion is very different, affords certain objects of considerable interest to the Microscopist. The whole of their structure is penetrated to so extraordinary a degree by *silex*, that, even when the organic portion has been destroyed by prolonged maceration in dilute nitric acid, a consistent skeleton still remains. This mineral, in fact, constitutes in some species not less than 13 per cent. of the whole solid matter, and 50 per cent. of their inorganic ash. The cuticle, which is used by cabinet-makers for smoothing the surface of wood, becomes, through the peculiar arrangement of its siliceous particles, an extremely beautiful object under polarized light. Of these particles (each of which has a regular axis of double refraction), some are distributed in two lines, parallel to the axis; others, however, are grouped into oval forms, connected with each other, like the jewels of a necklace, by a chain of particles forming a sort of curvilinear quadrangle; and these (which are, in fact, the particles occupying the cells of the stomata) are arranged in pairs.—What is usually designated as the fructification of the

several weeks, and then suddenly watered, a large number of antheridia and archegonia simultaneously open, and in a few hours afterwards, the surface of the larger prothallia will be found almost covered with moving antherozoids. Such prothallia as exhibit freshly-opened archegonia, are now to be held by one lobe between the fore-finger and thumb of the left-hand, so that the upper surface of the prothallium lies upon the thumb; and the thinnest possible sections are then to be made, with a thin narrow-bladed knife, perpendicularly to the surface of the prothallium. Of these sections, which, after much practice, may be made no more than 1-15th of a line in thickness, some will probably lay open the canals of the archegonia: and within these, when examined with a power of 200 or 300 diameters, antherozoids may be occasionally distinguished.

Equisetaceæ, forms a cone or spike at the extremity of certain of the stem-like branches (the real stem being a hori-

FIG. 148.

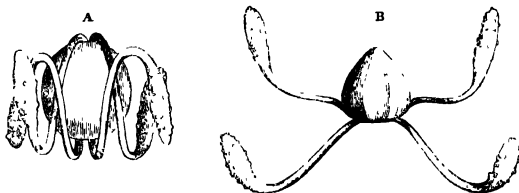
Spores of *Equisetum*.

zontal rhizoma); and consists of a cluster of shield-like disks, each of which carries a circle of *theceæ* or spore-cases, that open by longitudinal slits to set-free the spores. Each of these bodies has, attached to it, a pair of elastic filaments (Fig. 148), that are originally formed as spiral fibres on the interior of the wall of the primary cell within which the spore is generated, and are set-free by its rupture; these are at first coiled-up closely around the spore, in the manner represented at A, though more closely applied to the surface; but, on the slightest application of moisture, they suddenly extend themselves in the manner shown at B; and this motion, like the extension of the spiral elaters of *Marchantia*, probably serves to assist in the dispersion of the spores. If a number of the spores be spread-out on a slip of glass under the field of view, and, whilst the observer watches them, a bystander breathe gently upon the glass, all the filaments will be instantaneously put in motion,—thus presenting an extremely curious spectacle,—and will almost as suddenly return to their previous condition, when the effect of the moisture has passed-off. These spores are to be regarded in the same light as those of Ferns; namely, as *gemmæ* or rudimentary buds, not as seeds. They evolve themselves after the like method into a prothallium; and this develops antheridia and archegonia, by the conjoint action of which an embryo is produced.

221. In ascending, as we have now done, from the lower to the higher Cryptogamia, we have seen a gradual change in the general plan of structure, so that the superior forms present a close approximation to the Flowering Plant, which is undoubtedly the highest type of Vegetation. But we have

everywhere encountered a mode of Generation, which, whilst essentially the same throughout the series, is essentially distinct from that of the Phanerogamia; the fertilizing material of the 'sperm-cell' being embodied, as it were, in self-moving filaments, which find their way to the germ-cells by their own independent movements; and the 'embryo-cell' being destitute of that store of prepared nutriment, which surrounds it in the true seed, and serves as the pabulum for its early development. In the lower Cryptogamia, we have seen that the embryo-cell, after fertilization, is thrown at once upon the world (so to speak) to get its own living; but in the Liverworts, Mosses, and Ferns, the embryo-cell is nurtured by the parent-plant, for a period that varies in each case according to the nature of the fabric into which it evolves itself. While the true reproduction of the species is effected by the proper Generative act, the multiplication of the individual is accomplished by the production and dispersion of spores; and this production, as we have seen, takes place at very different periods of existence in the several groups, dividing the life of each into two separate epochs, in which it presents itself under two very distinct phases that contrast remarkably with each other. Thus, the frond of the *Marchantia*, bearing its antheridia and archegonia, is that which seems naturally to constitute *the* plant; but that which represents it in the Ferns, is the minute *Marchantia*-like prothallium. On the other hand, the product into which the fertilized embryo-cell evolves itself in the Ferns, is that which is commonly regarded as *the* plant; and this is represented in the Liverworts and Mosses by the spore-capsules alone.—We shall notice, in the next Chapter (§ 256), the representation of these two phases in the life of the Flowering Plant, which is traceable by means of the study of the *Lycopodiaceæ* and *Coniferae*; two groups that form the link of transition between these two great divisions of the Vegetable kingdom, the former being probably to be regarded as the highest of the Cryptogamia, and the latter as the lowest of the Phanerogamia.*

* See the Author's "Principles of Comparative Physiology," 4th Edit. §§ 499-505.

CHAPTER VIII.

OF THE MICROSCOPIC STRUCTURE OF PHANEROGAMIC PLANTS.

222. *Elementary Tissues.*—In passing from the Cryptogamic division of the Vegetable Kingdom, to that larger and more ostensibly-important province which includes the Flowering-Plants, we do not meet with so wide a departure from those simple types of structure we have already considered, as the great differences in general aspect and external conformation might naturally lead us to expect. For a very large proportion of the fabric of even the most elaborately-formed Tree, is made up of components of the very same kind with those which constitute the entire organisms of the simplest Cryptogamia; and that proportion always includes the parts most actively concerned in the performance of the vegetative functions. For although the stems, branches, and roots, of trees and shrubs, are principally composed of *woody* tissue, such as we do not meet-with in any but the highest Cryptogamia, yet the special office of this is to afford mechanical support; when it is once formed, it takes no further share in the vital economy, than to serve for the conveyance of fluid from the roots, upwards through the stem and branches, to the leaves; and even in these organs, not only the pith and the bark, with the ‘medullary rays’ which serve to connect them, but that ‘cambium-layer’ intervening between the bark and the wood (§ 240), in which the periodical formation of the new layers both of bark and wood takes place, are composed of *cellular* substance. This tissue is found, in fact, wherever *growth* is taking-place; as, for example, in the spongioles or growing-points of the root-fibres, in the leaf-buds and leaves, and in the flower-buds and sexual parts of the flower: it is only when these organs attain an advanced stage of development, that woody structure is found in them,—its purpose (as in the stem) being merely to give support to their softer textures; and the small proportion of their substance which it forms, being at once seen in those beautiful skeletons, which, by a little skill and perseverance, may be made of leaves, flowers, and certain fruits. All the softer and more pulpy tissue of

these organs is composed of *cells*, more or less compactly aggregated together, and having forms which approximate more or less closely to the globular or ovoidal, which may be considered as their original type.

223. As a general rule, the rounded shape is preserved only when the cells are but loosely aggregated, as in the parenchymatous (or fleshy) substance of leaves (Fig. 149); and it is then only, that the distinctness of the walls becomes evident. When the tissue becomes more solid, the sides of the vesicles

FIG. 149.

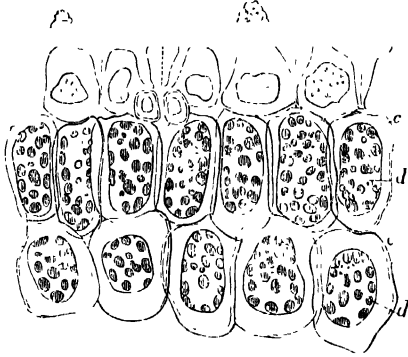

Section of leaf of *Agave*, treated with dilute nitric acid, showing the primordial utricles contracted in the interior of the cells — *a*, epidermic cells, *b*, boundary-cells of the stoma; *c*, cells of parenchyma; *d*, their primordial utricles.

are pressed against each other, so as to flatten them and to bring them into close apposition; and they then adhere to one another in such a manner, that the partitions appear, except when carefully examined, to be single, instead of being (as they really are) double. Frequently it happens that the pressure is exerted more in one direction than in another, so that the form presented by the outline of the cell varies according to the direction in which the section is made. This is well shown in the pith of the young shoots of Elder, Lilac, or other rapidly-growing trees; the cells of which, when cut transversely, generally exhibit circular outlines, whilst, when the section is made vertically, their borders are straight, so as to make them appear like cubes or elongated prisms, as in Fig. 152.

A very good example of such a cellular parenchyma is to be found in the substance known as 'Rice-paper;' which is made by cutting the herbaceous stem of a Chinese plant termed *Aralia papyrifera*,* vertically round and round, with a long sharp knife, so that its tissue may be (as it were) unrolled in a sheet. The shape of the cells, as seen in the rice-paper thus prepared, is irregularly prismatical, as shown in Fig. 150, B; but if the stem be cut transversely, their outlines are seen to

Fig. 150.

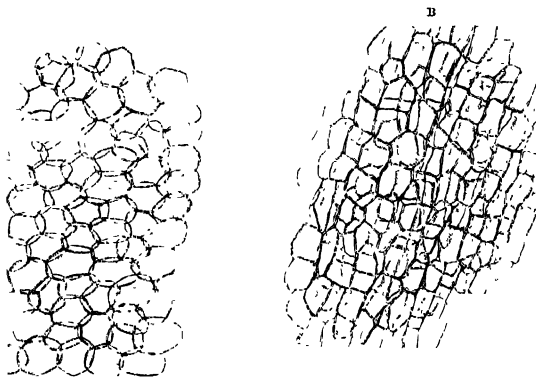

Sections of Cellular Parenchyma of *Aralia*, or Rice-paper plant;—
A, transversely to the axis of the stem; B, in the direction of the axis.

be circular or nearly so (A). When, as often happens, the cells have a very elongated form, this elongation is in the direction of their growth, which is that, of course, wherein there is least resistance. Hence their greatest length is nearly always in the direction of the axis; but there is one remarkable exception,—that, namely, which is afforded by the 'medullary rays' of Exogenous stems (§ 239), whose cells are greatly elongated in the horizontal direction (Fig. 161, a), their growth being from the centre of the stem towards its circumference. It is obvious that fluids will be more readily transmitted in the direction of greatest elongation, being that in which they will have to pass through

* The *Æschynomene*, which is sometimes named as the source of this article, is an Indian plant, employed for a similar purpose.

the least number of partitions; and whilst their ordinary course is in the direction of the length of the roots, stem, or branches, they will be enabled, by means of the medullary rays, to find their way in the transverse direction.—One of the most curious varieties of form which Vegetable cells present, is that represented in Fig. 151,

which constitutes the *stellate* cell. This modification, to which we have already seen an approximation in the *Volvox* (§ 159), is found in the spongy parenchymatous substance where lightness is an object; as in the stems of many aquatic plants, such as the *Rush*, which need to be furnished with air-spaces. In other instances, these air-spaces are large cavities, which are altogether left void of tissue; such is the case in the *Nuphar lutea* (Yellow water-lily), the footstalks of whose leaves contain large air-chambers, the walls of which are built-up of very regular cubical cells, whilst some curiously-formed large stellate-cells project into the cavity which they bound (Fig. 152).

—The dimensions of the component vesicles of Cellular tissue are extremely variable; for although their diameter is very commonly between 1-300th and 1-500th of an inch, they occa-

FIG. 151.

Section of Cellular parenchyma of *Rush*.

FIG.

Cubical parenchyma, with stellate cells from petiole of *Nuphar lutea*.

sionally measure as much as 1-30th of an inch across, whilst in other instances they are not more than 1-3000th.

224. The component cells of Cellular tissue are usually held together by an intercellular substance, which may be considered analogous to the 'gelatinous' layer that intervenes between the cells of the Algæ. There are many cellular substances, however, in which, in consequence of the loose aggregation of their component cells, these may be readily isolated, so as to be prepared for separate examination without the use of reagents which alter their condition; this is the case with the pulp of ripe fruits, such as the Strawberry or Currant (the Snowberry is a particularly favourable subject for this kind of examination), and with the parenchyma of many fleshy leaves, such as those of the Carnation (*Dianthus caryophyllus*) or the London-pride (*Saxifraga crassifolia*). Such cells usually contain evident *nuclei*, which are turned brownish-yellow by iodine, whilst their membrane is only turned pale-yellow; and in this way the nucleus may be brought into view, when, as often happens, it is not previously distinguishable. If a drop of the iodized solution of chloride of zinc be subsequently added, the cell-membrane becomes of a beautiful blue colour, whilst the nucleus and the granular protoplasm that surrounds it, retain their brownish-yellow tint. The use of dilute nitric or sulphuric acid, of alcohol, of syrup, or of several other reagents, serves to bring into view the 'primordial utricle' of Mohl; its contents being made to coagulate and shrink, so that it detaches itself from the cellulose-wall with which it is ordinarily in contact, and shrivels-up within its cavity, as shown in Fig. 149.

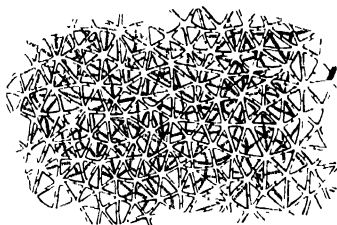
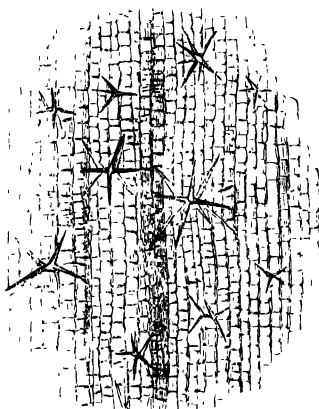
225. It is probable that all cells, at some stage or other of their growth, exhibit, in a greater or less degree of intensity, that curious movement of 'rotation,' which has been already described as occurring in the *Characeæ* (§ 201), and which consists in the steady flow of one or of several currents of protoplasm over the inner wall of the cell; this being rendered apparent by the movement of the particles which the current carries along with it. The best examples of it are found among submerged plants, in the cells of which it continues for a much longer period than it usually does elsewhere; and among these there are two, the *Vallisneria spiralis* and the *Anacharis alsinastrum*, which are peculiarly fitted for the exhibition of this interesting phenomenon. The former is an aquatic plant that grows abundantly in the rivers of the south of Europe, but is not a native of this country; it may, however, be readily grown in a tall glass jar having at the bottom

a couple of inches of mould, which, after the roots have been inserted into it, should be closely pressed-down, the jar being then filled with water, of which a portion should be occasionally changed.* The jar should be freely exposed to light, and should be kept in as warm but equal a temperature as possible. The long grass-like leaves of this plant are too thick to allow the transmission of sufficient light through them for the purpose of this observation; and it is requisite to make a thin slice or shaving with a sharp knife. If this be taken from the surface, so that the section chiefly consists of the superficial layer of cells, these will be found to be small, and the particles of chlorophyll, though in great abundance, will rarely be seen in motion. But if, after the removal of this layer, a deeper stratum be sliced-off, this will be found to consist of larger cells, some of them greatly elongated, with particles of chlorophyll in smaller number, but carried along in active rotation by the current of protoplasm; and it will often be noticed, that the rotation takes place in contiguous cells in opposite directions. If the movement (as is generally the case) be checked by the shock of the operation, it will be revived again by a gentle warmth; and it may continue under favourable circumstances, in the separated fragment, for a period of weeks or even of months. Hence when it is desired to exhibit the phenomenon, the preferable method is to make the sections a little time before they are likely to be wanted, and to carry them in a small vial of water in the waistcoat pocket, so that they may receive the gentle and continuous warmth of the body. In summer, when the plant is in its most vigorous state of growth, the section may be taken from any one of the leaves; but in winter, it is preferable to select those which are a little yellow.†—The *Anacharis almanstrum* is a water-weed, which, having been accidentally introduced into this country about twelve years ago, has since spread itself with such rapidity through our canals and rivers, as, in many instances, seriously to impede the navigation. It does not require to root itself in the bottom, but floats in any part of the water it inhabits; and it is so tenacious of life, that even small fragments are sufficient for the origination of new plants.

* Mr. Quekett has found it the most convenient method of changing the water in the jars in which *Chara*, *Vallisneria*, &c., are growing, to place them occasionally under a water-tap, and allow a very gentle stream to fall into them for some hours, for by the prolonged overflow thus occasioned, all the impure water, with the conferva that is apt to grow on the sides of the vessel, may be readily got rid-of.

† An object-glass of 1-4th inch focus affords the best power for the observation of this interesting phenomenon.

The leaves have no distinct cuticle, but are for the most part composed of two layers of cells, and these are elongated and colourless in the centre, forming a kind of midrib; towards the margins of the leaves, however, there is but a single layer. Hence no preparation whatever is required for the exhibition of this interesting phenomenon; all that is necessary being to take a leaf from the stem (one of the older yellowish leaves being preferable), and to place it with a drop of water either in the aquatic box, or on a slip of glass beneath a thin-glass cover. A higher magnifying power is required, however, than that which suffices for the examination of the rotation in *Chara* or *Vallisneria*; the 1-8th inch object-glass being here preferable to the 1-4th, and the assistance of the Achromatic condenser being desirable. With this amplification, the phenomenon may be best studied in the single layer of marginal cells; although, when a lower power is used, it is most evident in the elongated cells forming the central portion of the leaf. The number of chlorophyll-granules in each cell varies from three or four to upwards of fifty; they are somewhat irregular in shape, some being nearly circular flattened disks, whilst others are oval; and they are usually from 1-3000th to 1-5000th of an inch in diameter. When the rotation is active, the greater number of these granules travel round the margin of the cells, a few, however, remaining fixed in the centre; their rate of movement, though only 1-10th of an inch per minute, being sufficient to carry them several times round the cell within that period. As in the case of the *Vallisneria*, the motion may frequently be observed to take place in opposite directions in contiguous cells. The thickness of the layer of protoplasm in which the granules are carried round, is estimated by Mr. Wenham at no more than 1-20,000th of an inch. A peculiar undulating appearance is seen in this, under certain modes of illumination, which suggests the idea of ciliary action; but this appearance is decidedly affirmed by Mr. Wenham to be an optical illusion. It is a curious circumstance, first remarked by Dr. Branson, that the elongated cells along the margin of the leaf and forming the midrib, contain a large quantity of siliceous matter; as may be readily seen by polarized light, especially after the leaf has been boiled for a few minutes in equal parts of nitric acid and water, which removes part of the vegetable substance, and thus renders the siliceous portion more distinct, without destroying the form of the leaf.*

* See Dr. Branson in "Quart. Journ. of Microsc. Science," vol. ii. p. 131, and vol. iii, p. 371, and Mr. Wenham, *Op. cit.*, vol. iii, p. 277.

226. The phenomenon of 'rotation,' however, is by no means restricted to submerged Plants; for it has been witnessed by numerous observers in so great a variety of other species, that it may fairly be presumed to be universal. It is especially observable in the *hairs* of the epidermic surface; and according to Mr. Wenham, who has recently given much attention to this subject, "the difficulty is to find the exceptions, for hairs taken alike from the loftiest Elm of the forest, to the humblest weed that we trample beneath our feet, plainly exhibit this circulation." Such hairs are furnished by various parts of plants; and what is chiefly necessary is, that the part from which the hair is gathered should be in a state of vigorous growth. The hairs should be detached by tearing off, with a pair of fine-pointed forceps, the portion of the cuticle from which they spring; care being taken not to grasp the hair itself, whereby such an injury would be done to it, as to check its circulation. The hair should then be placed with a drop of water under thin glass; and it will generally be found advantageous to use a 1-8th in. objective, with an achromatic condenser having a series of diaphragms—The nature of the movement in the hairs of different species of plants is far from being uniform. In some instances, the currents pass in single lines along the entire length of the cells, as in the hairs from the filaments of the *Tradescantia virginica* or Virginian spider-wort, (Fig. 153, A); in others, there are several such currents which retain their distinctness, as in the jointed hairs of the calyx of the same plant (B); in others, again, the streams coalesce into a network, the reticulations of which change their position at short intervals, as in the hairs of *Glaucium luteum*; whilst, lastly, the current may flow in a sluggish uniformly-moving sheet or layer. Where several distinct currents exist in one cell, they are all found to have one common point of departure and return, namely the 'nucleus' (B, a); from which it seems fairly to be inferred, that this body is the centre of the vital activity of the cell.* Mr. Wenham states that in all cases in which the sap-motion is seen in the hairs of a plant, the cells of the cuticle also display it, provided that their walls are not so opaque or

* The above statement is called in question by Mr. Wenham, who affirms that "whenever he has observed such a 'nucleus,' it has either been formed by an accidental conglomeration of some of the cell-contents, or by morbid conditions"—The Author is satisfied, however, from the constancy with which the 'nucleus' is the centre of the diverging lines of protoplasm, in those cells which have several streams radiating from one point, that it can neither be an accidental nor a morbid conglomeration.

so strongly marked, as to prevent the rotation from being distinguished.* The cuticle may be most readily torn-off from the stalk or the midrib of the leaf; and must then be examined as speedily as possible, since it loses its vitality, when thus detached, much sooner than do the hairs. Even where no obvious movement of particles is to be seen, the existence of a rotation may be concluded from the peculiar arrangement of the molecules of the protoplasm, which are remarkable for their high refractive power, and which, when arranged in a 'moving train,' appears as bright lines across the cell; and these lines, on being carefully watched, are seen to alter their relative positions. The leaf of the common *Plantago* (plantain or dock) furnishes an excellent example of 'rotation'; the movement being distinguishable at the same time, both in the cells and in the hairs of the cuticle torn from its stalk or midrib.—

FIG. 153.

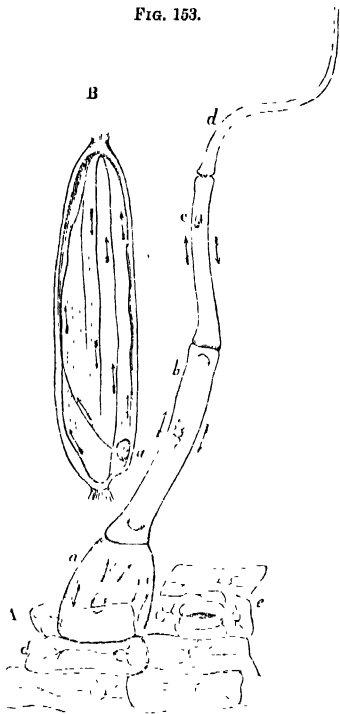

Circulation of fluid in hairs of *Tradescantia Virginica*.—A, portion of cuticle with hair attached; a, b, c, successive cells of the hair d, cells of the cuticle; e, stoma; f, joint of a beaded hair, showing several currents, a, nucleus.

It is a curious circumstance, that when a plant (such as the

* Op. cit., vol. iv. p. 44.

Anacharis) which exhibits the 'rotation,' is kept in a cold dark place for one or two days, not only is the movement suspended, but the moving particles collect-together in little heaps; these being again broken-up by the separate motion of their particles, when the stimulus of light and warmth occasions a renewal of the circulatory action. It is well to collect the specimens about mid-day, that being the time when the rotation is most active; and the movement is usually quickened by artificial warmth, which, indeed, is a necessary condition in some instances to its being seen at all. The most convenient method of applying this warmth, while the object is on the stage of the microscope, is to blow a stream of air upon the thin-glass cover, through a glass or metal tube previously heated in a spirit lamp.

227. The walls of the cells of Plants are frequently thickened by internal deposits, which may present very different appearances according to the manner in which they are arranged. In its simplest condition, such a deposit forms a thin uniform layer over the whole internal surface of the cellulose-wall (probably on the outside of the primordial utricle), scarcely detracting at all from its transparency, and chiefly distinguishable by the 'dotted' appearance which the membrane then presents (Fig. 150, A). These dots, however, are not pores, as their aspect might naturally suggest; but are merely points at which the deposit is wanting, so that the original cell-wall there remains unthickened. When the cellular tissue is required to possess unusual firmness, a deposit of *sclerogen* (a substance which, when separated from the resinous and other matters that are commonly associated with it, is found to be allied in chemical composition to cellulose) is formed in successive layers, one within another (Fig. 154, A), which present themselves

FIG. 154.

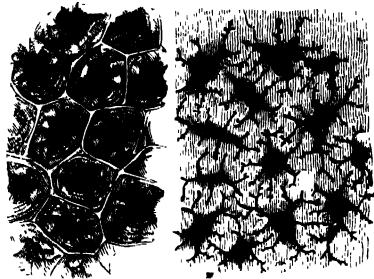

† Tissue of the Testa of the seed-coat of *Star-Anise*.—A, as seen in section; B, as seen on the surface.

as concentric rings when the cells containing them are cut through; and these layers are sometimes so thick and numerous, as almost to obliterate the original cavity of the cell. By a continuance of the same arrangement as that which shows itself in the single layer of the dotted cell,—each deposit being deficient at certain points, and these points corresponding with each other in the successive layers,—a series of passages is left, by which the cavity of the cell is extended at some points to its membranous wall; and it commonly happens that the points at which the deposit is wanting on the walls of two contiguous cells, are coincident, so that the membranous partition is the only obstacle to the communication between their cavities (Figs. 154–156). It is of such tissue that the ‘stones’ of fruit, the gritty substance

FIG. 155.

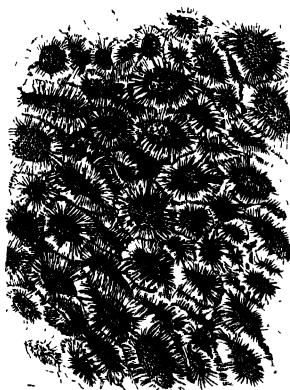

Section of *Cherry Stone*, cutting the cells transversely.

FIG. 156.



Section of *Coquilla Nut*, in the direction of the long diameters of the cells.

which surrounds the seeds and forms little hard points in the fleshy substance of the pear, the shell of the cocoa-nut, and the albumen of the seed of *Phytelphas* (known as ‘vegetable ivory’), are made-up; and we see the use of this very curious arrangement, in permitting the cells, even after they have attained a considerable degree of consolidation, still to remain

permeable to the fluid required for the nutrition of the parts which such tissue encloses and protects.

228. The deposit sometimes assumes, however, the form of definite *fibres*, which lie coiled-up in the interior of cells, so as to form a single, a double, or even a triple or quadruple spire (Fig. 157). Such 'spiral cells' are found most abundantly in the leaves of certain Orchideous plants, immediately beneath the cuticle, where they are brought into view by vertical sections; and they may be obtained in an isolated state, by macerating the leaf and peeling-off the cuticle, so as to expose the layer beneath, which is then easily separated into its components. In an Orchideous plant named, *Sac-*

FIG. 157.

Spiral cells of leaf of *Oncidium*.

colobium guttatum, the spiral cells are unusually long, and have spires winding in opposite directions; so that, by their mutual

intersection, a series of diamond-shaped markings is produced. Spiral cells are often found upon the surface of the *testa* or outer coat of seeds; and in the *Collomia grandiflora*, the *Salvia verbenaca* (wild clary), and some other plants, the membrane of these cells is so weak, and the elasticity of their fibres so great, that when the membrane is softened by the action of water, the fibres suddenly uncoil and elongate themselves (Fig. 158), springing-out, as it were, from the surface of the seed, to which they give

FIG. 158.

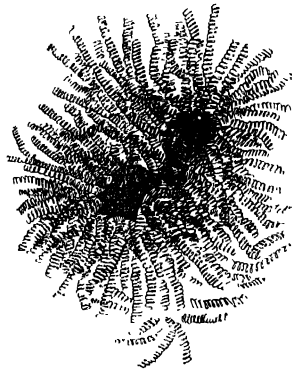
Spiral fibres of Seed-coat of *Collomia*.

a peculiar flocculent appearance. This very curious pheno-

menon, which greatly perplexes those who are ignorant of its real nature, may be best observed in the following manner:—A very thin transverse slice of the seed should first be cut, and laid upon the lower glass of the aquatic-box; the cover should then be pressed-down, and the box placed upon the stage, so that the body of the microscope may be exactly ‘focussed’ to the object, the power employed being the 1 inch, 2-3rds inch, or the $\frac{1}{2}$ inch objective. The cover of the aquatic box being then removed, a small drop of water should be placed on that part of its internal surface, with which the slice of the seed had been in contact; and the cover being replaced, the object should be immediately looked-at. It is important that the slice of the seed should be very thin, for two reasons; first, that the view of the spires may not be confused by their aggregation in too-great numbers; and second, that the drop of water should be held in its place by capillary attraction, instead of running-down and leaving the object, as it will do if the glasses be too widely separated.

229. In some part or other of most Plants, we meet with cells containing granules of *Starch*. These granules are sometimes minute and very numerous, and are so closely packed together as to fill the cavity (Fig. 159); in other instances

FIG. 159.

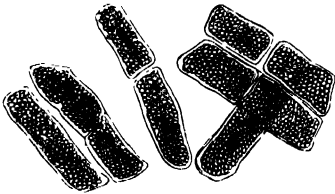
Cells of *Pæony*, filled with Starch.

they are of much larger dimensions, so that only a small number of them can be included in any one cell; while in other cases, again, they are both few and minute, so that they form but a small proportion of the cell-contents. Their nature is at once detected by the addition of a solution of iodine, which gives them a beautiful blue colour. Each granule exhibits a peculiar spot termed the *hilum*, which marks the point at which, in its early state, it is attached to the cell-wall; and it also presents, when highly magnified, a set of circular lines, which are for the most part concentric (or nearly so) with the hilum. When viewed by polarized light (§ 63), each grain exhibits a beautiful dark cross, the point of intersection being at the hilum (Fig. 160).—Regarding the internal

structure of the starch-grain, opinions are very much divided; for whilst some affirm the concentric lines to indicate the existence of a number of concentric lamellæ, one enclosing another, others consider that they are due to the peculiar plaiting or involution of a single vesicular wall;* and among those who consider it to be concentrically lamellated, some hold that each lamella is formed *outside* or *upon* that which preceded it, while others consider that each is formed *inside* or *within* its predecessor.

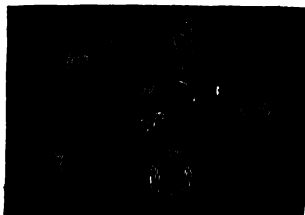

Granules of *Starch*, as seen under polarized light.

The centre of the granule is often occupied by starchy matter in an unconsolidated state; and it is the appearance arising from its different refractive power, that has caused some observers to describe the starch-grain as possessing a nucleus.—Although the dimensions of the starch-grains produced by any one species of Plant are by no means constant, yet there is a certain average for each, from which none of them depart very widely; and by reference to this average, the starch-grains of different plants that yield this product in abundance, may be microscopically distinguished from one another,—a circumstance of considerable importance in commerce. The largest starch-grains in common use are those of the plant (a species of *Canna*) known as *Tous les mois*; the average diameter of those of the *Potato* is about the same as the diameter of the smallest of the 'tous les mois;' and the size of the ordinary starch grains of *Wheat* and of *Sago* is about the same as that of the smallest grains of potato-starch; whilst the granules of *Rice*-starch are so very minute, as to be at once distinguished from any of the preceding.

230. Deposits of mineral matter in a crystalline condition,

* The first of these opinions is the one which had been generally received until recently, when Mr. G. Busk supported the latter by new observations made upon the unfolding of the starch-granule by dilute sulphuric acid; since when, Prof. Allman, after repeating Mr. Busk's observations, has been led to affirm them to be fallacious, and to revert to the first of the above-mentioned doctrines.—See Mr. Busk's memoir in "Trans. of Microsc. Soc." ser. 2, vol. i. p. 58, and that of Prof. Allman in "Quart. Journ. of Microsc. Sci." vol. ii. p. 163.

known as *Raphides*, are not unfrequently found in the cells of Plants; where they are at once brought into view by the use of polarized light. Their designation (derived from $\rho\alpha\phi\iota\varsigma$, a needle) is very appropriate to one of the most common states in which these bodies present themselves, that, namely, of bundles of needle-like crystals, lying side-by-side in the cavity of the cell; such bundles are well seen in the cells lying immediately beneath the cuticle of the bulb of the medicinal Squill. It does not apply, however, to other forms which are scarcely less abundant; thus, instead of bundles of minute needles, single large crystals, octohedral or prismatic, are frequently met-with; and the prismatic crystals are often aggregated in beautiful stellate groups. One of the most common materials of raphides, is oxalate of lime, which is generally found in the stellate form; and no plant yields these stellate raphides so abundantly as the common *Rhubarb*, the best specimens of the dry medicinal root containing as much as 35 per cent. of them. In the cuticle of the bulb of the *Onion*, the same material occurs under the octohedral or the prismatic form. In other instances, the calcareous base is combined with tartaric, citric, or malic acid; and the acicular raphides are said to consist usually of phosphate of lime. Some raphides are as long as 1-40th of an inch, while others measure no more than 1-1000th. They occur in all parts of plants,—the wood, pith, bark, root, leaves, stipules, sepals, petals, fruit, and even in the pollen. They are always situated in cells, and not, as some have stated, in the intercellular passages; the cell-membrane, however, is often so much thinned-away, as to be scarcely distinguishable.—Certain plants of the *Cactus* tribe, when aged, have their tissues so loaded with raphides as to become quite brittle; so that when some large specimens of *C. senilis*, said to be a thousand years old, were sent to Kew Gardens from South America, some years since, it was found necessary for their preservation during transport, to pack them in cotton, like jewellery.—It is not yet known what office the raphides fulfil in the economy of the Plant; or whether they are to be considered in any other light, than as non-essential results of the vegetative processes. For as all these processes require the introduction of mineral bases from the soil, and themselves produce organic acids in the substance of the plant, it may be surmised that the accidental union of the components will occasion the formation of raphides wherever such union may occur; and this view is supported by the fact, that the late Mr. E. Quckett succeeded

in artificially producing raphides within the cells of 'rice paper' (§ 223), by first filling these with lime water by means of the air-pump, and then placing the paper in weak solutions of phosphoric and oxalic acids. The artificial raphides of phosphate of lime were rhombohedral; while those of oxalate of lime were stellate, exactly resembling the natural raphides of the Rhubarb.*

231. A large proportion of the denser parts of the fabric of the higher Plants, is made-up of the substance which is known as *Ligneous Tissue*, or *Woody Fibre*. This, however, can only be regarded as a very simple variety of the 'cellular;' for it is composed of peculiarly-elongated cells (Fig. 171, *a a*), usually pointed at their two extremities so as to become spindle-shaped, whose walls have a special tendency to undergo consolidation by the internal deposit of sclerogen. It is obvious that a tissue consisting of elongated cells, adherent together by their entire length, and strengthened by internal deposit, must possess much greater tenacity than any tissue in which the cells depart but little from the primitive spherical form; and we accordingly find Woody Fibre introduced, wherever it is requisite that the fabric should possess not merely density, but the power of resistance to tension. In the higher classes of the Vegetable kingdom, it constitutes the chief part of the stem and branches, where these have a firm and durable character; and even in more temporary structures, such as the herbaceous stems of annual plants, and the leaves and flowers of almost every tribe, this tissue forms a more or less important constituent, being especially found in the neighbourhood of the spiral vessels and ducts, to which it affords protection and support. Hence the bundles or fasciculi composed of these elements, which form the skeletons of leaves, and which give 'stringiness' to various esculent vegetable substances, are commonly known under the name of *fibro-vascular tissue*. In their young and unconsolidated state, the ligneous cells seem to conduct fluids with great facility in the direction of their length; and in the *Coniferous* tribe whose stems and branches are destitute of vessels, they afford

* The materials of the above paragraph are derived from the excellent section on this subject in Prof. Quekett's "Lectures on Histology."—Besides the vegetables therein named as affording good illustrations of different kinds of Raphides, may be mentioned, the parenchyma of the leaf of *Agave*, *Aloe*, *Cycas*, *Eucephalartos*, &c., the cuticle of the bulb of the *Hyacinth*, *Tulip*, and *Garlic* (and probably of other bulbs), the bark of the *Apple*, *Cascarilla*, *Conchou*, *Lime*, *Locust*, and many other trees, the pith of *Eleagnus*, and the testa of the seeds of *Anagallis* and the *Elm*.

the sole channel for the ascent of the sap. But after their walls have become thickened by internal deposit, they are no longer subservient to this function; nor, indeed, do they then appear to fulfil any other purpose in the Vegetable economy, than that of affording mechanical support. It is this which constitutes the difference between the *alburnum* or 'sap-wood,' and the *duramen* or 'heart-wood,' of Exogenous stems (§ 238).—A peculiar set of markings, seen on the woody fibres of the *Coniferae*, and of some other tribes, is represented in Fig. 161; in each of these spots, the inner

FIG. 161.

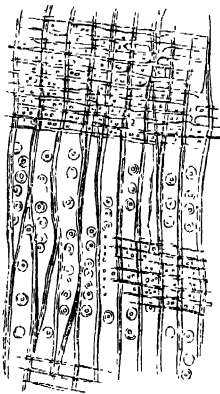

Section of *Coniferous Wood* in the direction of the fibres, showing their 'glandular' dots; *a a a*, medullary rays crossing the fibres.

a minute fragment, even of a fossil wood, the tribe to which it belonged. The woody fibre thus marked, is often designated as 'glandular.'

232. All the more perfect forms of Phanerogamia contain, in some part of their fabric, the peculiar structures which are known as *Spiral Vessels*.* These have the elongated shape of

* So long, however, as they retain their original cellular character, and do not coalesce with each other, these fusiform spiral cells cannot be regarded as having any more claim to the designation of *vessels*, than have the elongated cells of the ligneous tissue.

circle appears to mark a deficiency of the lining deposit, as in the porous cells of other plants; whilst the *outer* circle indicates the boundary of a lenticular cavity, which intervenes between the adjacent cells at this point, and which contains a small globular body that may be sometimes detached. Of the purpose of these minute bodies interposed between the wood-cells, nothing is known; there can be no doubt, however, from the definiteness and constancy of their arrangement, that they fulfil some important object in the economy of the plants in which they occur; and there are varieties in this arrangement so characteristic of different tribes, that it is sometimes possible to determine, by the microscopic inspection of

woody fibres; but the internal deposit, as in the 'spiral cells' (§ 228), takes the form of a spiral fibre winding from end to end, remaining distinct from the cell-wall, and retaining its elasticity; this fibre may be single, double, or even quadruple,—this last character presenting itself in the very large elongated fibre-cells of the *Nepenthes* (Chinese pitcher-plant). These cells are especially found in the delicate membrane ('medullary sheath') surrounding the pith of Exogens, and in the midst of the woody bundles occurring in the stem of Endogens; thence they proceed in each case to the leaf-stalks, through which they are distributed to the leaves. By careful dissection under the microscope, they may be separated entire; but their structure may be more easily displayed, by cutting *round*, but not *through*, the leaf-stalk of the Strawberry, Geranium, &c., and then drawing the parts asunder. The membrane composing the tubes of the vessels will thus be broken-across; but the fibres within, being elastic, will be drawn-out and unrolled. Spiral vessels are sometimes found to convey liquid, whilst in other cases they contain air only; the conditions of this difference are not yet certainly known.

233. Although fluid generally finds its way with tolerable facility through the various forms of Cellular tissue, especially in the direction of the greatest length of its cells, a more direct means of connection between distant parts is required for an active circulation. This is afforded by what has been termed *Vasiform tissue*, which consists merely of cells laid end-to-end, the partitions between them being more or less obliterated, so that a continuous *Duct* is formed. The origin of these ducts in cells is occasionally very evident, both in the contraction of their calibre at regular intervals, and in the persistence of the remains of their partitions (Fig. 175, *bb*); but in most cases it can only be ascertained by studying the history of their development, neither of these indications being traceable. The component cells appear to have been sometimes simply membranous, but more commonly to have possessed the fibrous type (§ 228). Some of the ducts formed from the latter (Fig. 162, 2) are so like continuous spiral vessels, as to be scarcely distinguishable from them, save in the want of elasticity in the spiral fibre, which causes it to break when the attempt is made to draw it out. This would seem to have taken place, in some instances, from the natural elongation of the cells by growth; the fibre being broken-up into rings, which sometimes lie close together, but more commonly at considerable intervals; such a duct is said to be *annular*

(Fig. 162, 1). Intermediate forms between the spiral and annular ducts, which show the derivation of the latter from

FIG. 162.

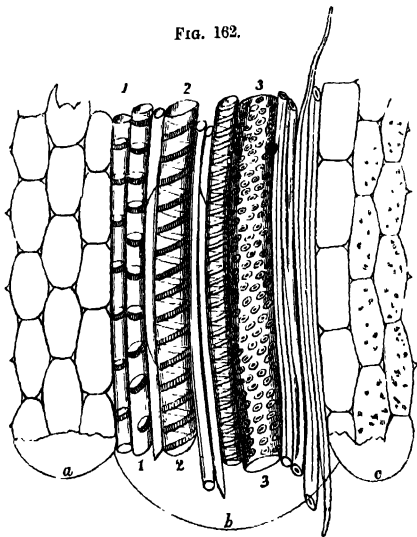

Longitudinal section of stem of *Italian Reed*:—a, cells of the pith, b, fibro-vascular bundle, containing, 1. annular duct; 2. spiral duct; 3. dotted duct, with woody fibre; c, cells of the integument.

the former, are very frequently to be met-with. The spirals are sometimes broken-up still more completely, and the fragments of the fibre extend in various directions, so as to meet and form an irregular network lining the duct, which is then said to be *reticulated*. The continuation of the deposit, however, gradually contracts the meshes, and leaves the walls of the duct marked only by pores like those of porous cells (§ 227); and canals upon this plan, commonly designated as *dotted ducts*, are among the most common forms of vasiform tissue, especially in parts of most solid structure and least rapid growth (Fig. 162, 3). The 'scalariform' ducts of Ferns (§ 218) are for the most part of the spiral type; but spiral ducts are frequently to be met-with also in the rapidly-growing leaf-

stalks of Flowering-plants, such as the Rhubarb. Not unfrequently, however, we find all forms of ducts in the same bundle, as seen in Fig. 162. The size of these ducts is occasionally so great, as to enable their openings to be distinguished by the unaided eye. They are usually largest in stems, whose size is small in proportion to the surface of leaves which they support, such as the common Cane, or the Vine; and generally speaking they are larger in woods of dense texture, such as Oak or Mahogany, than in those of which the fibres, being softer, can themselves be subservient to the conveyance of fluid. They are entirely absent in the Coniferae.

231. The Vegetable Tissues, whose principal forms have been now described, but among which an immense variety of detail is found, may be either studied as they present themselves in thin *sections* of the various parts of the plant under examination, or in the isolated condition in which they are obtained by *dissection*.—The former process is the most easy, and yields a large amount of information: but still it cannot be considered that the characters of any tissue have been properly determined, until it has been dissected-out. Sections of some of the hardest vegetable substances, such as ‘vegetable-ivory,’ the ‘stones’ of fruit, the ‘shell’ of the cocoa-nut, &c. (§ 227), can scarcely be obtained except by slicing and grinding (§ 108); and these may be mounted either in Canada balsam or in weak spirit. In cases, however, in which the tissues are of only moderate firmness, the section may be readily and most effectually made with the ‘Section-Instrument’ (§ 107); and there are few parts of the Vegetable fabric which may not be advantageously examined by this means, any very soft or thin portions being placed in it between two pieces of cork. In certain cases, however, in which even this compression would be injurious, the sections must be made with a sharp knife, the substance being laid upon a slip of glass.—In dissecting the Vegetable tissues, scarcely any other instrument will be found really necessary, than a pair of needles (in handles), one of them ground to a cutting edge. The adhesion between the component cells, fibres, &c., is often sufficiently weakened by a few hours’ maceration, to allow of their readily coming-apart, when they are torn-asunder by the needle-points beneath the simple lens of a dissecting-microscope. But if this should not prove to be the case, it is desirable to employ some other method, for the sake of facilitating their isolation. None is so effectual

as the boiling of a thin slice of the substance under examination, either in dilute nitric acid, or in a mixture of nitric acid and chlorate of potass. This last method (which was devised by Schultz) is the most rapid and effectual, requiring only a few minutes for its performance; but as oxygen is liberated with such freedom as to give an almost explosive character to the mixture, it should be put in practice with extreme caution. After being thus treated, the tissue should be boiled in alcohol, and then in water; and it will then be found very easy to tear-apart the individual cells, ducts, &c., of which it may be composed. These may be preserved by mounting in weak spirit.

235. *Structure of the Stem and Root.*—It is in the stems and roots of Plants, that we find the greatest variety of tissues in combination, and the most regular plans of structure; and sections of these, viewed under a low magnifying power, are objects of peculiar beauty, independently of the scientific information which they afford. The Axis (under which term is included the Stem with its branches, and the Root with its ramifications) always has for the basis of its structure a dense cellular parenchyma; though this, in the advanced stage of development, may constitute but a small proportion of it. In the midst of this parenchyma we generally find fibro-vascular bundles; that is, fasciculi of woody-fibre, with ducts of various kinds, and (very commonly) spiral vessels. It is in the mode of arrangement of these bundles, that the fundamental difference exists between the stems that are commonly designated as *Endogenous*, and those which are (more appropriately) termed *Exogenous*; for in the former, the bundles are dispersed throughout the whole diameter of the axis, without any peculiar plan, the intervals between them being filled-up by cellular parenchyma; whilst in the latter they are arranged side by side, in such a manner as to form a hollow cylinder of *wood*, which includes within it that portion of the cellular substance which is known as *pith*, whilst it is itself enclosed in an envelope of the same substance, that forms the *bark*. These two plans of axis-formation,—respectively characteristic of those two great groups into which the Phanerogamia are subdivided, namely the *Monocotyledonous*, and the *Dicotyledonous*,—will now be more particularly described.

236. When a transverse section (Fig. 163) of a *Monocotyledonous* stem is examined microscopically, it is found to exhibit a number of fibro-vascular bundles, disposed without any regularity in the midst of the mass of cellular tissue,

which forms (as it were) the matrix or basis of the fabric. Each bundle contains two, three, or more large ducts, which

FIG. 163.

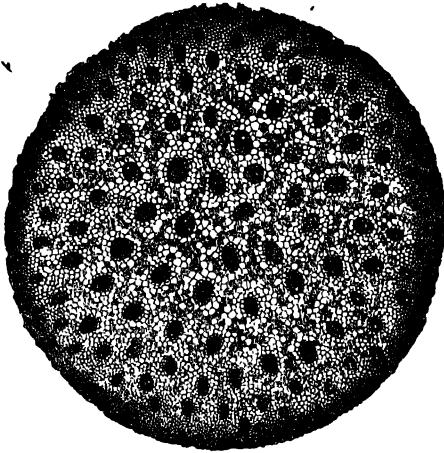
Section of Stem of young *Palm*.

are at once distinguished by the size of their openings; and these are surrounded by woody fibre and spiral vessels, the transverse diameter of which is so extremely small, that the portion of the bundles which *they* form is at once distinguished in transverse section, by the *closeness* of its texture (Fig. 164). The bundles are least numerous in the centre of the stem, and become gradually more approximated towards the circumference: but it frequently happens that the portion of the area in which they are most compactly arranged, is not absolutely at its exterior, this portion being itself surrounded by an investment composed of cellular tissue only; and sometimes we find the central portion, also, completely destitute of fibro-vascular bundles; so that a sort of indication of the distinction between pith, wood, and bark is here presented. This distinction, however, is very imperfect; for we do not find either the central or the peripheral portions ever separable, like pith and bark, from the intermediate woody

layer. In its young state, the centre of the stem is always filled-up with cells; but these not unfrequently disappear after

FIG. 164.

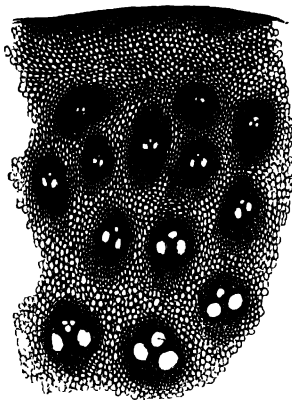

Portion of transverse section of stem
of *Wanghce Cane*.

a time, except at the nodes, leaving the stem hollow, as we see in the whole tribe of Grasses. When a vertical section is made of a woody stem (as that of a Palm) of sufficient length to trace the whole extent of the fibro-vascular bundles, it is found that whilst they pass at their upper extremity into the leaves, they pass at the lower end, also, towards the surface of the stem, and assist, by their interlacement with the outer bundles, in forming that extremely tough investment, which the lower ends of these stems present. The fibro-vascular bundles once formed, receive no further additions; and the augmen-

tation of the stem in diameter depends upon the development of new woody bundles, in continuity with the leaves which are successively evolved at its summit. It was formerly supposed that these successively-formed bundles descend in the interior of the stem through its entire length, until they reach the roots; and as the successive development of leaves involves a successive development of new bundles, the stem was imagined to be continually receiving additions to its interior, whence the term *Endogenous* was given to this type of stem-structure. From the fact just stated, however, regarding the course of the fibro-vascular bundles, it is obvious that such a doctrine cannot be any longer admitted; for those which are most recently formed only pass into the centre of the stem during the higher part of their course, and usually make their way again to its exterior at no great distance below; and thus the lower and older portions of a Palm-stem really do receive very little augmentation in diameter, while a rapid elongation is taking place at its summit. In fact, the dense unyielding nature of the fabric, which is formed by the interlacement of the fibro-vascular bundles at or near the

surface of the trunk, would prevent any such augmentation by expanding pressure from within.

237. In the stems of *Dicotyledonous* Phanerogamia, we find a method of arrangement of the several parts, which must be regarded as the highest form of the development of the axis, being that in which the greatest *differentiation* exists. A distinct division is always seen in a transverse section, between the three concentric areas of the *pith*, the *wood*, and the *bark*; the first (*a*) being central and the last (*b*) peripheral, and these having the wood interposed between them, its circle being made-up of wedge-shaped bundles (*d, d*), kept-apart by the bands (*c, c*) that pass between the pith and the bark.

—The *Pith* (Fig. 165, *a*) is almost invariably composed of cellular tissue only, which usually presents (in transverse section) a hexagonal arcolation. When newly formed, it has a greenish hue, and its cells

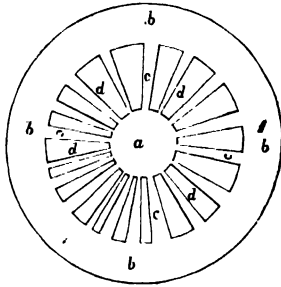
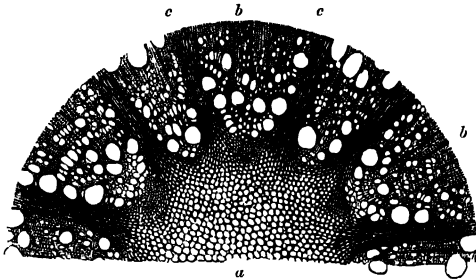

Diagram of the first formation of an Exogenous stem; *a*, pith; *b, b*, bark; *c, c*, plates of cellular tissue (medullary rays) left between the woody bundles *d, d*.

FIG. 165.



Transverse section of young stem of *Clematis*:—*a*, pith; *b, b, b*, woody bundles; *c, c, c*, medullary rays.

are filled with fluid; but it gradually dries-up and loses its colour; and not unfrequently its component cells are torn-apart by the rapid growth of their envelope, so that irregular cavities

are found in it; or, if the stem should increase with extreme rapidity, it becomes hollow, the pith being reduced to fragments which are found adhering to its interior wall. The pith is immediately surrounded by a delicate membrane, consisting almost entirely of spiral vessels, and termed the 'medullary sheath.'

238. The *Woody* portion of the stem (Fig. 165, *b, b*) is made up of woody fibres, usually with the addition of ducts of various kinds; these, however, are absent in one large group, the *Coniferae* or Fir tribe with its allies (Figs. 166, 170-172), in

FIG. 166.

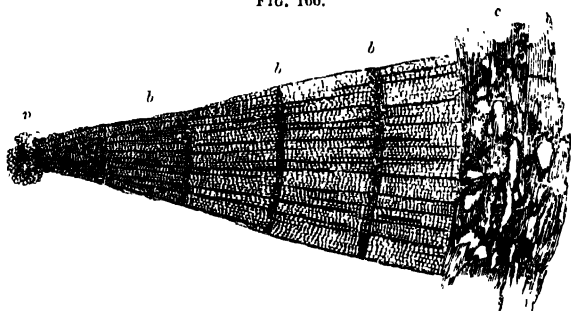

Portion of transverse section of stem of Cedar.—*a*, pith, *b, b*, wood; *c*, bark.

which the woody fibres are of unusually large diameter, and have the peculiar 'glandular' markings already described (§ 231). In any stem or branch of more than one year's growth, the woody structure presents a more or less distinct appearance of division into concentric rings, the number of which varies with the age of the tree (Fig. 167). The composition of the several rings, which are the sections of so many cylindrical layers, is uniformly the same, however different their thickness; the arrangement of the two principal elements, however,—namely the woody fibre and the ducts,—varies in different species; the ducts being sometimes almost uniformly diffused through the whole layer, but in other instances being confined to its inner part; while in other cases, again, they are dispersed with a certain regular irregularity (if such an expression may be allowed), so as to give a curiously-figured appearance to the transverse section

(Figs. 167, 168). The general fact, however, is, that the ducts predominate towards the inner side of the ring (which is the part of it first formed), and that the outer portion of each layer is almost exclusively composed of woody tissue; such an arrangement is seen in Fig. 165. This alternation of ducts and woody fibre frequently serves to mark the succession of layers, when, as is not uncommon, there is no very distinct line of separation between them. The number of layers is usually considered to correspond with that of the years during which the stem or branch has

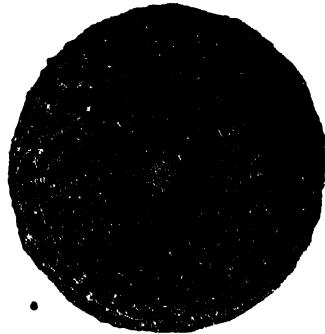

Transverse section of stem of *Buckthorn* (*Rhamnus*).

been growing; and this is, no doubt, generally true in regard to the trees of temperate climates. There appears strong reason to believe, however, that such is not the universal rule; and that we should be more correct in stating that each layer indicates an 'epoch of vegetation;' which, in temperate climates, is usually (but not invariably) a year, but which is commonly much less in the case of trees flourishing in tropical regions. For example, we not unfrequently meet with stems, in which the place of a layer of the ordinary breadth is occupied by two narrow layers; the line of demarcation between them having apparently been formed by a temporary interruption to

FIG. 168.

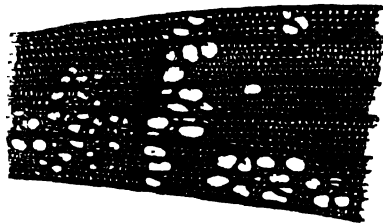

Portion of the preceding figure, more highly magnified.

For example, we not unfrequently meet with stems, in which the place of a layer of the ordinary breadth is occupied by two narrow layers; the line of demarcation between them having apparently been formed by a temporary interruption to

the process of growth, in the middle of the period through which the formation of wood extends. Such an interruption might occur from heat and drought, in a tree that flourishes best in a cold damp atmosphere, or from a fall of temperature in a tree that requires heat; and in a variable season, it might recur several times. Something of this kind would appear to have been the cause of the peculiar appearance presented by a section of Hazel-stem (in the Author's possession), of which a portion is represented in Fig. 169; for between two layers of

FIG. 169.



Portion of transverse section of stem of *Hazel*, showing, in the portion *a, b, c*, six narrow layers of wood.

the ordinary thickness, there intervenes a band whose breadth is altogether less than that of either of them, and which is yet composed of no fewer than six layers, four of them (*c*) being very narrow, and each of the other two being about as wide as these four together.—The inner layers of wood are the oldest, and the most solidified by matters deposited within their component cells and vessels; hence they are spoken of collectively under the designation *duramen* or 'heart-wood.' On the other hand, it is through the cells and ducts of the outer and newer layers, that the sap rises from the roots towards the leaves; and these are consequently designated as *alburnum* or 'sap-wood.' The line of demarcation between the two is sometimes very distinct, as in *Lignum-vitæ* and *Cocos* wood; and as a new layer is added every year to the exterior of the alburnum, an additional layer of the innermost part of the alburnum is every year consolidated by internal deposit, and is thus added to the exterior of the duramen. More generally, however, this consolidation is gradually effected, and the alburnum and duramen are not separated by any abrupt line of division.

239. The *Medullary Rays* which cross the successive rings of wood connecting the cellular substance of the pith with that

of the bark, and dividing each ring of wood into wedge-shaped segments, are thin plates of cellular tissue (Fig. 165, *c, c*), not usually extending to any great depth in the vertical direction. It is not often, however, that their character can be so clearly seen in a transverse section, as it is in that just referred-to; for they are usually compressed so closely, as to appear darker than the wedges of woody tissue between which they

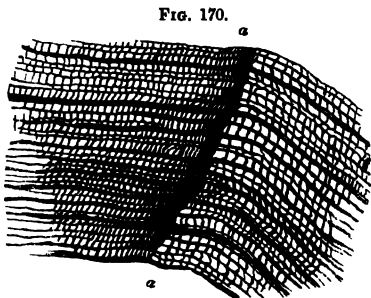
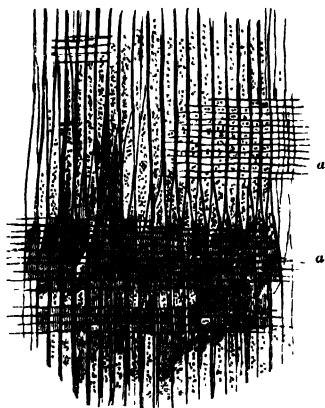

FIG. 170.

Portion of transverse section of large stem of *Coniferous Wood* (fossil), showing part of two annual layers, divided at *a, a*, and traversed by very thin but numerous Medullary Rays.

FIG. 171.



Portion of vertical section of the same wood, taken in a radial direction, showing the glandular woody fibres, without ducts, crossed by the Medullary Rays, *a, a*.

FIG. 172.

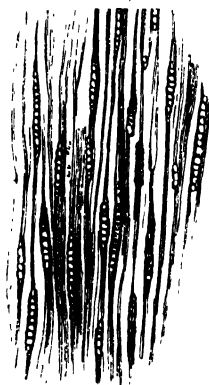

Portion of vertical section of the same wood, taken in a tangential direction, so as to cut across the Medullary Rays.

intervenc (Figs. 166-169); and their real nature is best understood by a comparison of *longitudinal* sections made in two different directions,—namely, *radial* and *tangential*,—with the transverse. Three such sections of a fossil Coniferous wood in the Author's possession are shown in Figs. 170-172. The stem was of such large size, that, in so small a part of the area of its transverse section as is represented in Fig. 170, the medullary rays seem to run parallel to each other, instead of radiating from a common centre. They are very narrow; but are so closely set-together, that only two or three rows of woody fibres (no ducts being here present) intervene between any pair of them. In the longitudinal section taken in a radial direction (Fig. 171), and consequently passing in the same course with the medullary rays, these are seen as thin plates (*a, a, a*) made-up of superposed cells very much elongated, and crossing, in a horizontal direction, the glandular woody fibres which lie parallel to one another vertically. And in the tangential section (Fig. 172), which passes in a direction at right angles to that of the medullary rays, and

Fig. 173.

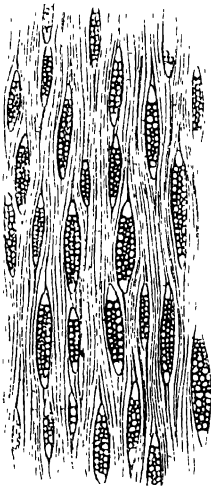
Vertical section of *Mahogany*.

therefore cuts them across, we see that each of the plates thus formed has a very limited depth from above downwards, and is composed of no more than one thickness of horizontal cells.—A section of the stem of *Mahogany*, taken in the same direction as the last (Fig. 173), gives a very good view of the cut ends of the medullary rays, as they pass between the woody fibres; and they are seen to be here of somewhat greater thickness, being composed of two or three rows of cells, arranged side by side.—In another fossil wood, whose transverse section is shown in Fig. 174, and its tangential section in Fig. 175, the medullary rays are seen to occupy a much larger part of the substance of the stem; being seen in the transverse section as broad bands (*aa, aa*), intervening between the closely-set

woody fibres, among which some large ducts are scattered; whilst in the tangential, they are observed to be not only deeper

FIG. 174.

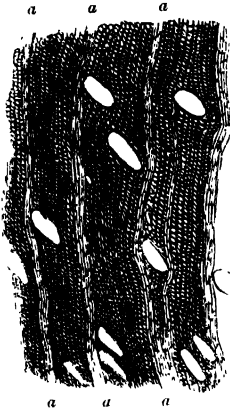

Portion of transverse section of Fossil Wood, showing the Medullary Rays, *a a, a a, a a*, running nearly parallel to each other, and the openings of the large Ducts in the midst of the woody fibres.

FIG. 175.



Portion of vertical (tangential) section of the same Wood, showing the woody fibres separated by the Medullary Rays, and by the large Ducts, *b b, b b*.

than the preceding from above downwards, but also to have a much greater thickness. This section also gives an excellent view of the ducts *b b, b b*, which are here plainly seen to be formed by the coalescence of large cylindrical cells, lying end-to-end — In another fossil wood in the Author's possession, the medullary rays constitute a still larger proportion of the stem; for in the transverse section (Fig. 176), they are seen as very broad bands (*b, b*), alternating with plates of woody structure (*a, a*), whose thickness is often less than their own; whilst in the tangential section (Fig. 177), the cut extremities of the medullary rays occupy a very large part of the area, having apparently determined the sinuous course of the woody fibres; instead of looking, as in Fig. 172, as if they had forced their way between the woody fibres, which there hold a nearly straight and parallel course on either side of them.

240. The *Bark* may be usually found to consist of three principal layers: the external, or *epiphlæum*, also termed the

FIG. 176.



Portion of transverse section of a Fossil Wood, remarkable for the very large size of the Medullary Rays, *b, b*, which separate the woody plates, *a, a*.

FIG. 177.

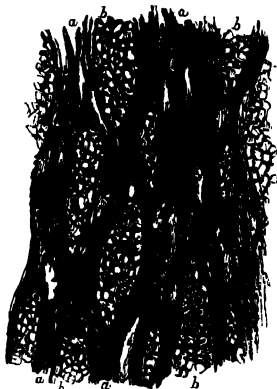

Vertical (tangential) section of the same wood, showing, *a, a*, the woody bundles, and *b, b*, the Medullary Rays.

suberosus (or corky) layer; the middle, or *mesophlæum*, also termed the 'cellular envelope;' and the internal, or *endophlæum*, which is more commonly known as the *liber*. The two outer layers are entirely cellular; and are chiefly distinguished by the form, size, and direction of their cells. The *epiphlæum* is generally composed of one or more layers of colourless or brownish cells, which usually present a cubical or tabular form, and are arranged with their long diameters in the horizontal direction: it is this which, when developed to an unusual thickness, forms *Cork*, a substance which is by no means the product of one kind of tree exclusively, but which exists in greater or less abundance in the bark of every exogenous stem. The *mesophlæum* consists of cells, usually of green colour, prismatic in their form, and disposed with their long diameters parallel to the axis; it is more loosely arranged than the preceding, and contains 'intercellular passages,' which often form a network of canals that have been termed 'laticiferous vessels;' and although usually less developed than the suberosus layer, it sometimes constitutes

the chief thickness of the bark. The *liber* or inner bark, on the other hand, usually contains woody fibre in addition to the cellular tissue and laticiferous vessels of the preceding; and thus approaches more nearly in its character to the woody layers, with which it is in close proximity on its inner surface. The liber may generally be found to be made-up of a succession of thin layers, equalling in number those of the wood, the innermost being the last formed; but no such succession can be distinctly traced in the cellular envelope, or in the suberous layer; although it is certain that they too augment in thickness by additions to their interior, whilst their external portions are frequently thrown-off in the form of thickish plates, or detach themselves in smaller and thinner flakes.—The bark is always separated from the wood by the *cambium-layer*, which is the part wherein all new growth takes place: this seems to consist of mucilaginous semifluid matter; but it is really made-up of cells of a very delicate texture, which gradually undergo transformations, whereby they are for the most part converted into woody tissue, ducts, spiral vessels, &c. These materials are so arranged, as to augment the fibro-vascular bundles of the wood on their external surface; thus forming a new layer of alburnum, which *encloses* all those that preceded it; whilst they also form a new layer of liber, on the *interior* of all those which preceded it: they also extend the medullary rays, which still maintain a continuous connection between the pith and the bark; and a portion remains unconverted, so as always to keep-apart the liber and alburnum.—This type of stem-structure is termed *Exogenous*; a designation which applies very correctly to the mode of increase of the woody layers, although (as we have just seen) the liber is formed upon a truly endogenous plan.

241. Numerous departures from the normal type are found in particular tribes of Exogens. Thus in some, the wood is not marked by concentric circles, their growth not being interrupted by any seasonal change. In other cases, again, each woody zone is separated from the next, by the interposition of a thick layer of cellular substance. Sometimes wood is formed in the bark (as in *Calycanthus*), so that several woody columns are produced, which are quite independent of the principal woody axis, but cluster around it. Occasionally the woody stem is divided into distinct segments, by the peculiar thickness of certain of the medullary rays; and in the stem of which Fig. 178 represents a transverse section, these cellular plates form four large segments, disposed in the

manner of a Maltese cross, and alternating with the four woody segments, which they equal in size.

FIG. 178.

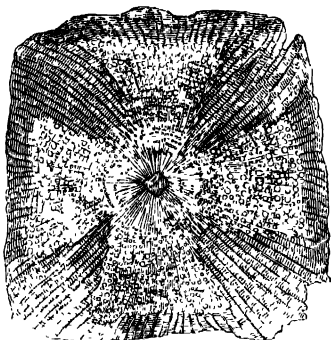

Transverse section of the stem of a Climbing-plant (*Aristolochia*?) from New Zealand.

FIG. 179.

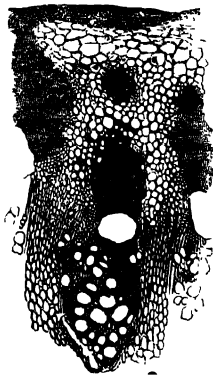

Portion of transverse section of *Burdock* (*Arietium*), showing one of the fibro-vascular bundles, that lies beneath the cellular integument.

242. In its first-developed state, the Exogenous stem consists, like the so-called endogenous, of cellular tissue only; but after the leaves have been actively performing their functions for a short time, we find a circle of fibro-vascular bundles, as represented in the diagram, p. 431, interposed between the central (or medullary) and the peripheral (or cortical) portions of the cellular matrix; these fibro-vascular bundles being themselves separated from

each other by plates of cellular tissue, which still remain to connect the central and the peripheral portions of the matrix. This first stage in the formation of the Exogenous axis, in which its principal parts—the pith, wood, bark, and medullary rays—are marked-out, is seen even in the stems of herbaceous plants, which are destined to die down at the end of the season (Fig. 179); and sections of these, which are very easily prepared, are most interesting Microscopic objects. In such stems, the difference between the 'Endogenous' and the 'Exogenous' types is manifested in little else than the disposition of the fibro-vascular layers; which are scattered through nearly the whole of the cellular matrix (although most abundant towards its exte-

rior), in the former case; but are limited to a circle within the peripheral portion of the cellular tissue, in the latter. It is in the further development which takes place during succeeding years in the woody stems of perennial Exogens, that those characters are displayed, which separate them most completely from the Ferns and their allies, whose stems contain a cylindrical layer of fibro-vascular bundles, as well as from (so called) Endogens. For whilst the fibro-vascular layers of the latter, when once formed, undergo no further increase, those of Exogenous stems are progressively augmented by the metamorphosis of the cambium-layer; so that each of the bundles which once lay as a mere series of parallel cords beneath the cellular investment of a first year's stem, may become in time the small end of a wedge-shaped mass of wood, extending continuously from the centre to the exterior of a trunk of several feet in diameter, and becoming progressively thicker as it passes outwards. The fibro-vascular bundles of Exogens are therefore spoken of as 'indefinite;' whilst those of Exogens and Acrogens (Ferns, &c.) are said to be 'definite' or 'closed.'

213. The structure of the *Roots* of Endogens and Exogens is essentially the same in plan with that of their respective stems. Generally speaking, however, the roots of Exogens have no pith, although they have medullary rays; and the succession of distinct rings is less apparent in them, than it is in the stems from which they diverge. In the delicate radical filaments which proceed from the larger root-fibres, a central bundle of vessels will be seen, enveloped in a sheath of cellular substance; and this investment also covers in the end of the fibril, which is usually somewhat dilated, and composed of peculiarly succulent tissue, forming what is termed the *spongiole*. The structure of the radical filaments may be well studied in the common *Duckweed*, every floating leaf of which has a single fibril hanging down from its lower surface.

214. The structure of Stems and Roots cannot be thoroughly examined in any other way than by making sections in different directions with the Section-instrument. The general directions already given (§ 107) leave little to be added respecting this special class of objects; the chief points to be attended to being the preparation the stems, &c., for slicing, the sharpness of the knife and the dexterity with which it is handled, and the method of mounting the sections when made. The wood, if green, should first be soaked in strong

alcohol for a few days, to get-rid of the resinous matter ; and it should then be macerated in water for some days longer, for the removal of its gum, before being submitted to the cutting-process. If the wood be dry, it should first be softened by soaking for a sufficient length of time in water, and then treated with spirit and afterwards with water, like green wood. Some woods are so little affected even by prolonged maceration, that boiling in water is necessary, to bring them to the degree of softness requisite for making sections. No wood that has once been dry, however, yields such good sections, as that which is cut fresh. When a piece, of the appropriate length, has been placed in the grasp of the Section-instrument (wedges of deal or other soft wood being forced-in with it, if necessary for its firm fixation), a few thick slices should first be taken, to reduce its surface to an exact level ; the surface should then be wetted with spirit, the micrometer-screw moved through a small part of a revolution, and the slice taken-off with the razor, the motion given to which should partake both of *drawing* and *pushing*. A little practice will soon enable the operator to discover, in each case, *how thin* he may venture to cut his sections, without a breach of continuity ; and the micrometer-screw should be turned so as to give the required elevation. If the surface of the wood has been sufficiently wetted, the section will not curl-up in cutting, but will adhere to the surface of the razor, from which it is best detached by dipping the razor in water, so as to float-away the slice of wood, a camel-hair pencil being used to push it off, if necessary. All the sections that may be found sufficiently thin and perfect, should be put-aside in a bottle of weak spirit, until they be mounted. For the minute examination of their structure, it is generally much better to preserve them in fluid, than to mount them either dry or in Canada balsam ; and no fluid answers better than weak spirit. Where a mere general view only is needed, the dry mounting answers the purpose sufficiently well. It is only in the case of the section being unusually opaque, that mounting it in Canada balsam can be of any service whatever ; and in general it is rather injurious than useful, making the section so transparent that its features can scarcely be discerned. Transverse sections, however, when charred by heating between two plates of glass until they turn brown, may be mounted with advantage in Canada balsam, and are then very showy specimens for the solar- or gas-microscope.—The number of beautiful and

interesting objects which may be thus obtained, at the cost of a very small amount of trouble, can scarcely be conceived save by those who have made a special study of these wonderful structures. Even the commonest trees, shrubs, and herbaceous plants, yield specimens that exhibit a varied elaboration of design, which cannot but strike with astonishment even the most cursory observer; and there is none in which a careful study of sections, made in different parts of the stem, and especially in the neighbourhood of the 'growing point,' will not reveal to the eye of the scientific Physiologist, some of the most important phenomena of Vegetation.—*Fossil Woods*, when well preserved, are almost invariably *silicified*, and require, therefore, to be cut and polished by a Lapidary. Should the Microscopist be fortunate enough to meet with a portion of a *calcified* stem, in which the organic structure is preserved, he should proceed with it after the manner of other hard substances which need to be reduced by grinding (§§ 108-110).

245. *Structure of the Cuticle and Leaves*.—On all the softer parts of the higher Plants, save such as grow under water, we find a superficial layer, different in its texture from the parenchyma beneath, and constituting a distinct membrane,

FIG. 180.

Cuticle of Leaf of *Yucca*.

FIG. 181.

Cuticle of Leaf of *Indian Corn*
(*Zea Mais*).

known as the *Cuticle*.* This membrane is composed of cells, the walls of which are flattened above and below, whilst they adhere closely to each other laterally, so as to form a continuous stratum (Fig. 184, *a, a*). Their shape is different in almost every tribe of Plants; thus in the cuticle of the *Yucca* (Fig. 180), *Indian Corn* (Fig. 181), *Iris* (Fig. 183), and most other Monocotyledons, the cells are elongated, and present an approach to a rectangular contour; their margins being straight in the *Yucca* and *Iris*, but minutely-sinuuous or crenated in the *Indian Corn*. In most Dicotyledons, on the

FIG. 182.

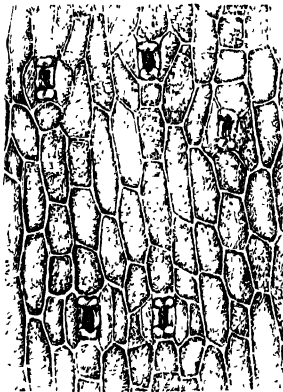
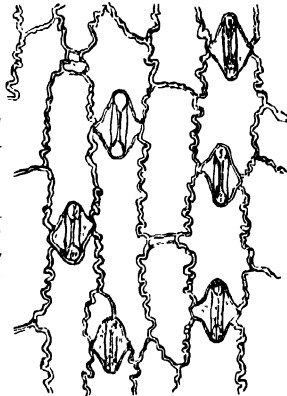

Portion of the Cuticle of the inferior surface of the Leaf of the *Apple*, with the layer of parenchyma in immediate contact with it — *a, a*, elongated cells of the cuticle overlying the veins or nerves of the leaf; *b, b*, ordinary cuticle-cells overlying the parenchyma; *c, c*, stomata; *d, d*, green cells of the parenchyma, forming a very open network near the lower surface of the leaf.

other hand, the cells of the cuticle depart less from the form of circular disks; but their margins usually exhibit large irregular sinuosities, so that they seem to fit-together like the pieces of a dissected map, as is seen in the cuticle of the *Apple* (Fig. 182, *b, b*). Even here, however, the cells of the

* The term *epidermis* is applied to this membrane by many Vegetable Physiologists, on account of the analogy it seems to present to the epidermis of Animals; but as epidermis means a membrane that lies upon the *derm* or 'true skin,' and as no such subjacent layer exists in the Plant, the transference of the designation is altogether inappropriate. It would be much more correct to designate by the name *cutis* or *derm* what is ordinarily denominated the Cuticle; and to reserve the term *epidermis* for the thin pellicle which may be sometimes detached from it (§ 247).

portion of the cuticle (*a, a*) that overlies the veins of the leaf, have an elongated form, approaching that of the wood-cells of which these veins are chiefly composed; and it seems likely, therefore, that the elongation of the ordinary cuticle-cells of Monocotyledons has reference to that parallel arrangement of the veins, which their leaves almost constantly exhibit.—The cells of the cuticle are colourless, or nearly so, no chlorophyll being formed in their interior; and their walls are generally thickened by secondary deposit, especially on the side nearest the atmosphere. This deposit is of a waxy nature, and consequently renders the membrane very impermeable to fluids; the retention of which within the soft tissue of the leaf is obviously the purpose to be answered by the peculiar organisation of the cuticle. In most European Plants, the cuticle contains but a single row of cells, which are usually, moreover, thin-sided; whilst in the generality of tropical species, there exist two, three, or even four layers of thick-sided cells; this last number being seen in the *Oleander*, the cuticle of which, when separated, has an almost leathery firmness. This difference in conformation is obviously adapted to the conditions of growth under which these plants respectively exist; since the cuticle of a plant indigenous to temperate climates, would not afford a sufficient protection to the interior structure against the rays of a tropical sun; whilst the diminished heat of this country would scarcely overcome the resistance presented by the dense and non-conducting tegument of a species formed to

FIG. 183.

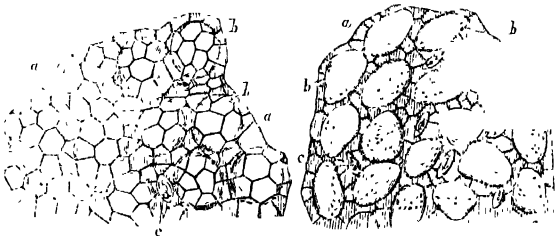

Portion of the Cuticle of the upper surface of the leaf of *Rochetia fulcata*, as seen at *A* from its inner side, and at *B* from its outer side: — *a, a*, small cells forming the inner layer of the cuticle, *b, b*, large prominent cells of the outer layer; *c, c*, stomata disposed between the latter

exist in tropical climates.—A very curious modification of the cuticle is presented by the *Rocoea falcata*, commonly known as the ‘ice-plant;’ a designation it owes to the peculiar appearance of its surface, which looks as if it were covered with frozen dewdrops. This appearance is occasioned by the presence of a layer of very large oval cells (Figs. 183, 184, *b, b*),

FIG. 184.

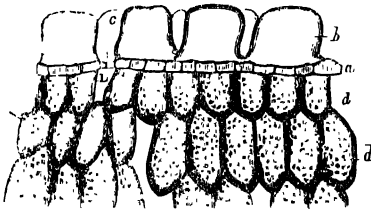

Portion of a vertical section of the same Leaf, showing the small cells, *a, a*, of the inner layer of cuticle; the large cells, *b, b*, of the outer layer; *c*, one of the stomata; *d, d*, cells of the parenchyma; *l*, lacuna between the parenchymatous cells, into which the stoma opens.

cells, but are more commonly made-up of a linear series, attached end-to-end, as in Fig. 153. Sometimes these hairs bear little glandular bodies at their extremities, by the secretion of which a peculiar viscidty is given to the surface of the leaf, as in the Sundew (*Drosera*); in other instances, the hair has a glandular body at its base, with whose secretion it is moistened; so that when this secretion is of an irritating quality, as in the *Nettle*, it constitutes a ‘sting.’ A great variety of such organs may be found, by a microscopic examination of the surface of the leaves of Plants having any kind of superficial investment to the cuticle. Many connecting links are found between hairs and scales, such as the ‘stellate hairs’ of the *Deutzia scabra*, which a good deal resemble those within the air-chambers of the Yellow Water-lily (Fig. 152).

246. The Cuticle in many Plants, especially those belonging to the *Grass* tribe, has its cell-walls impregnated with silex, like that of the *Equisetum* (§ 220); so that, when all the organic matter has been got-rid-of by heat or by acids, the forms of the cuticle-cells, hairs, stomata, &c., are still marked-out in silex, and are most beautifully displayed by Polarized

which lie detached one from another upon the surface of the ordinary cuticle, *a a*.—In other instances, the cuticle is partially invested by a layer of *scales*, which are nothing else than flattened cells, often having a very peculiar form; whilst in numerous cases, again, we find the surface beset with *hairs*, which occasionally consist of single elongated

light. Such silicified cuticles are found on the husks of the 'grains' yielded by these plants: and there is none in which a larger proportion of mineral matter exists, than that of *Rice*, which contains some curious elongated cells with toothed margins. The hairs with which the *paleæ* (chaff-scales) of most Grasses are furnished, are strengthened by the like siliceous deposit; and in the *Festuca pratensis*, one of the common meadow-grasses, the paleæ are also beset with longitudinal rows of little cup-like bodies formed of silica. The cuticle and scaly hairs of *Deutzia* also contain a large quantity of silex; and are remarkably-beautiful objects for the Polariscopes.

247. Externally to the cuticle, there usually exists a very delicate transparent pellicle, without any decided traces of organisation, though occasionally somewhat granular in appearance, and marked by lines that seem to be impressions of the junctions of the cells with which it was in contact. When detached by maceration, it not only comes-off from the surface of the cuticle, but also from that of the hairs, &c., which this may bear. This membrane, the proper *Epidermis* (p. 444, note), is obviously formed by the agency of the cells of the cuticle; and it seems to consist of the external layers of their thickened cellulose walls, which have coalesced with each other, and have separated themselves from the subjacent layers, by a change somewhat analogous to that which occurs in the *Palmellæ* (§ 194), the outer walls of whose original cells seem to melt-away into the gelatinous investment, that surrounds the 'broods' which have originated in their subdivision.

248. In nearly all Plants which possess a distinct Cuticle, this is perforated by the minute openings termed *Stomata* (Figs. 182, 183, *c, c*); which are bordered by cells of a peculiar form, distinct from those of the cuticle, and more resembling in character those of the tissue beneath. These boundary-cells are usually somewhat kidney-shaped, and lie in pairs (Fig. 185, *b, b*), with an oval opening between them; but by an alteration in their form, the opening may be contracted or nearly closed. In the cuticle of *Yucca*, however, the opening is bounded by two pairs of cells, and is somewhat quadrangular (Fig. 180); and a like doubling of the boundary-cells, with a narrower slit between them, is seen in the cuticle of the *Indian Corn* (Fig. 181). In the stomata of no Phanerogamic Plant, however, do we meet with any conformation at all to be compared in complexity with that which has been

described as existing in the humble *Marchantia* (214).—Stomata are usually found most abundantly (and sometimes exclu-

FIG. 185.

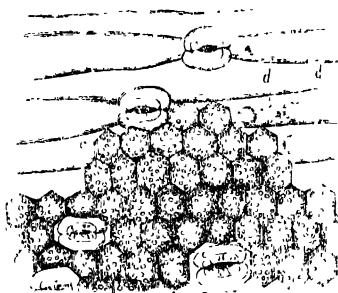

Portion of the Cuticle of the leaf of the *Iris germanica*, torn from its surface, and carrying away with it a portion of the parenchymatous layer in immediate contact with it --a, a, elongated cells of the cuticle, b, b, cells of the stomata; c, c, cells of the parenchyma, d, d, impressions formed by their contact, on the epidermic cells; e, e, lacunae in the parenchyma, corresponding to the stomata.

equally (or nearly so) on both surfaces. As a general fact, they are least numerous in succulent Plants, whose moisture, obtained in a scanty supply, is destined to be retained in the system; whilst they abound most in those which exhale fluid most readily, and therefore absorb it most quickly. It has been estimated that no fewer than 160,000 are contained in every square inch of the under surface of the leaves of *Hydrangea* and of several other plants; the greatest number seeming always to present itself in species, the upper surface of whose leaves is entirely destitute of these organs. In *Iris germanica*, each surface has nearly 12,000 stomata in every square inch; and in *Yucca*, each surface has 10,000.—In *Oleander*, *Banksia*, and some other plants, the stomata do not open directly upon the lower surface of the cuticle, but lie in the deepest part of little pits or depressions which are excavated in it, and which are lined with hairs; the mouths of these pits, with the hairs that line them, are well brought into view by taking a thin slice from the surface of

of the lower surfaces of leaves, where they open into the air-chambers that are left in the parenchyma which lies next the inferior cuticle; in leaves which float on the surface of water, however, they are found in the cuticle of the upper surface only; whilst, in leaves that habitually live entirely submerged, as there is no distinct cuticle, so there are no stomata. In the erect leaves of Grasses, the *Iris* tribe, &c., they are found

the cuticle with a sharp knife; but the form of the cavities, and the position of the stomata, can only be well made-out in vertical sections of the leaves.

249. The internal structure of *Leaves* is best brought into view by making vertical sections, that shall traverse the two layers of cuticle and the intermediate cellular parenchyma; portions of such sections are shown in Figs. 184, 186, and 187. In close apposition with the cells of the upper cuticle (Fig. 186, *a, a*), which may or may not be perforated with stomata (*c, c, d, d*), we find a layer of soft thin-walled cells, containing

a large quantity of chlorophyll; these cells usually press so closely against one another, that their sides become mutually flattened, and no spaces are left, save where there is a definite air-chamber into which the stoma opens (Fig. 184, *l*); and the compactness of this superficial layer is well

seen, when, as often happens, it adheres so closely to the cuticle, as to be carried-away with this when it is torn-away (Fig. 185, *c, c*). Beneath this first layer of leaf-cells, there are usually several others, rather less compactly arranged; and the tissue gradually becomes more and more lax, its cells not being in close apposition, and large intercellular passages being left amongst them, until we reach the lower cuticle, which the parenchyma only touches at certain points, its lowest layer forming a sort of network (Fig. 182, *d, d*), with large interspaces, into which the stomata open. It is to this arrangement that the darker shade of green almost invariably presented by the superior surfaces of leaves, is principally due; the colour of the component cells of the parenchyma not being deeper in one part of the leaf than in another.—In those

FIG. 186.

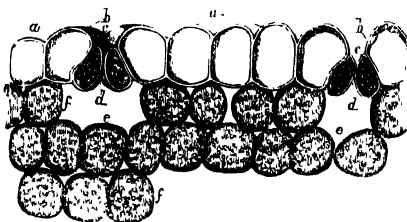

Vertical section of the Cuticle, and of a portion of the subjacent parenchyma, of a Leaf of *Iris germanica*, taken in a transverse direction:—*a, a*, cells of the cuticle; *b, b*, cells at the sides of the stomata; *c, c*, small green cells placed within these; *d, d*, openings of the stomata; *e, e*, lacunae of the parenchyma, corresponding to the stomata; *f, f*, cells of the parenchyma.

plants, however, whose leaves are erect instead of being horizontal, so that their two surfaces are equally exposed to light, the parenchyma is arranged on both sides in the same manner, and their cuticles are furnished with an equal number of stomata. This is the case, for example, with the leaves of the common Garden *Iris* (Fig. 187); of which, moreover, we find a central portion (*d, d*) formed by thick-walled colourless

FIG. 187.

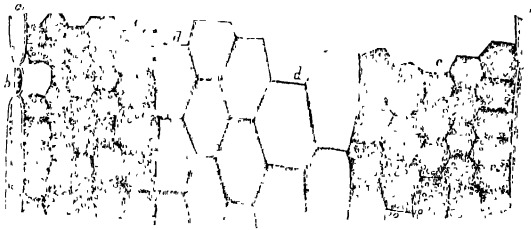

Portion of a vertical longitudinal section of the leaf of *Iris*, extending from one of its flattened sides to the other — *a, a*, elongated cells of the epiderms; *b, b*, stomata cut through longitudinally; *c, c*, green cells of the parenchyma, *d, d*, colourless tissue, occupying the interior of the leaf.

tissue, very different either from ordinary leaf-cells or from woody fibre. The explanation of its presence is probably to be found in the peculiar conformation of the leaves; for if we pull one of them from its origin, we shall find that what appears to be the flat expanded blade really exposes but half its surface; the blade being doubled-together longitudinally, so that what may be considered its under surface is entirely concealed. The two halves are adherent together at their upper part; but at their lower they are commonly separated by a new leaf, which comes-up between them; and it is from this arrangement, which resembles the position of the legs of a man on horseback, that the leaves of the *Iris* tribe are said to be *equitant*. Now by tracing the middle layer of colourless cells, *d, d*, down to that lower portion of the leaf, where its two halves diverge from one another, we find that it there becomes continuous with the cuticle, to the cells of which (Fig. 185, *a*) these bear a strong resemblance, in every respect save the greater proportion of their breadth to their length.—Another interesting variety in leaf-structure is presented by

the Water-Lily, and other plants whose leaves float on the surface; for here the usual arrangement is entirely reversed, the closely-set layers of green leaf-cells being found in contact with the lower surface, whilst all the upper part of the leaf is occupied by a loose spongy parenchyma, containing a very large number of air-spaces that give buoyancy to the leaf; and these spaces communicate with the external air through the numerous stomata, which, contrary to the general rule (§ 218), are here found in the upper cuticle alone.

250. The examination of the foregoing structures is attended with very little difficulty. Many cuticles may be torn-off, by the exercise of a little dexterity, from the surfaces of the leaves they invest, without any preparation; this is especially the case with Monocotyledonous plants, the 'veins' of whose leaves run parallel, and with such Dicotyledons as have very little woody structure in their leaves; in those, on the other hand, whose leaves are furnished with reticulated veins, to which the cuticle adheres (as is the case in by far the larger proportion), this can only be detached by first macerating the leaf for a few days in water; and if the texture of the cuticle should be particularly firm, the addition of a few drops of nitric acid to the water will render them more easily separable. If it be desired to preserve them, they may be advantageously mounted in weak spirit—Very good sections of most leaves may be made by a sharp knife, handled by a careful manipulator, but it is generally preferable to use Valentin's knife (§ 106) or the section-instrument (§ 107); taking care in the former case to cut-down upon a piece of fine cork; and in the latter not to crush the leaf between the two pieces of cork that hold it, and to use very soft cork whenever the delicacy of the leaf renders this desirable. In order to study the structure of leaves with the fulness that is needed for scientific research, numerous sections should be made in different directions; and slices taken parallel to the surfaces, at different distances from them, should also be examined. There is no known liquid, in which such sections can be preserved altogether without change; but water with a small dash of spirit, seems to answer best, provided the cell be air-tight, and the specimen fresh.

251. *Structure of Flowers.*—Many of the smaller Flowers are, when looked-at entire, with a low magnifying power, very striking Microscopic objects; and the interest of the young in such observations can scarcely be better excited, than by directing their attention to the new view they thus acquire of

the 'composite' nature of the humble down-trodden *Daisy*, or to the beauty of the minute blossoms of many of those *Umbelliferous* plants, which are commonly regarded only as rank weeds. The scientific Microscopist, however, looks more to the organization of the separate parts of the flower; and among these he finds abundant sources of gratification, not merely to his love of knowledge, but also to his taste for the beautiful. The general structure of the *Sepals* and *Petals*, which constitute the 'perianth' or 'floral envelopes,' closely corresponds with that of leaves; the chief difference lying in the peculiar change of hue which the chlorophyll almost invariably undergoes in the latter class of organs, and very frequently in the former also. There are some petals, however, whose cells exhibit very interesting peculiarities, either of form or marking, in addition to their distinctive coloration; such are those of the *Geranium* (*Pelargonium*), of which a small portion is represented in Fig. 188.

FIG. 188.

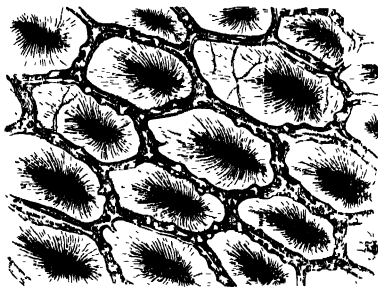

Cells from the Petal of the *Geranium*
(*Pelargonium*).

opaque spot with numerous diverging prolongations, which looks as if formed by a deposit of sclerogen upon its interior. This method of preparation, however, does not give a true idea of the structure of the cells; for each of them has a peculiar mammillary protuberance, the base of which is surrounded by hairs; and this it is which gives the velvety appearance to the surface of the petal, and which, when altered by drying and compression, occasions the peculiar spots represented in Fig. 188. The real cha-

—when it has been dried after stripping it of its cuticle, immersed for an hour or two in oil of turpentine, and then mounted in Canada balsam,—exhibit a most beautiful variety of vivid coloration, which is seen to exist chiefly in the thickened partitions of the cells; whilst the surface of each cell presents a very curious

acter may be brought into view by Dr. Inman's method; which consists in drying the petal (when stripped of its cuticle) on a slip of glass, to which it adheres, and then placing on it a little Canada balsam diluted with turpentine, which is to be boiled for an instant over the spirit-lamp, after which it is to be covered with a thin-glass. The boiling 'blisters' it, but does not remove the colour; and on examination, many of the cells will be found showing the mammilla very distinctly, with a score of hairs surrounding its base, each of these slightly curved, and pointing towards the apex of the mammilla. The petal of the common Scarlet Pimpernel (*Anagallis arvensis*), that of the common Chickweed (*Stellaria media*), together with many others of a small and delicate character, are also very beautiful microscopic objects; and the two just named are peculiarly favourable subjects for the examination of the spiral vessels in their natural position. For the 'veins' which traverse these petals are entirely made up of spiral vessels, none of which individually attain any great length; but one follows or takes the place of another, the conical commencement of each somewhat overlapping the like termination of its predecessor; and where the veins seem to branch, this does not happen by the bifurcation of a spiral vessel, but by the 'splicing-on' (so to speak) of one to the side of another, or by the 'splicing-on' of two new vessels diverging from one another, to the end of that which formed the principal vein.*

252. The *Anthers* and *Pollen-grains*, also, present numerous objects of great interest, both to the scientific Botanist and to the amateur Microscopist. In the first place, they afford a good opportunity of studying that 'free' cell-development, which seems peculiar to the parts concerned in the Reproductive process, and which consists in the development of a new cell-wall round an isolated mass of protoplasm forming part of the contents of a 'parent-cell;' so that the new cell lies free within its cavity, instead of being developed in continuity with it, as in the ordinary methods of multiplication (§§ 150, 198). If the Anther be examined, by thin sections, at an early stage of its development within the young flower-bud, it will be found to be made-up of ordinary cellular parenchyma, in which no peculiarity anywhere shows itself; but a gradual 'differentiation' speedily takes-place, consisting in the development of a set of very large cells in two vertical rows, which occupy the

* See Mr. R. H. Solly's description and figure of the petal of the *Anagallis*, in "Trans. of Soc. of Arts," vol. xlviii.

place of the *loculi* or pollen-chambers that afterwards present themselves; and these cells give origin to the pollen grains, whilst the ordinary parenchyma remains to form the walls of the pollen-chambers. The first change consists in the multiplication of the cells of the primary row, by cell-division, in correspondence with the general increase in the size of the anther; until at length they form masses of considerable size, composed of large squarish cells, filled with granular contents, well-defined as constituting a distinct tissue from the walls of the pollen-chambers. The history of the development of the pollen-grains in their interior is thus described by Mr. Henfrey, who has made a special study of it—“The contents of each of these cells secrete a layer of cellulose, which does not adhere to the wall of the parent-cell to form a layer of secondary deposit, but lies free against it, so that a new free cell is formed within each old one, nearly filling it. The walls of the old cells then dissolve, so that the free cells become free, no longer in their parent-cells, but in a cavity which is to constitute the pollen-chamber or loculus of the anther. These free cells are the ‘parent-cells of the pollen’ of authors. A new phenomenon soon occurs in these. These parent-cells divide into four by ordinary cell-division; either by one or two successive partings, by septa at right angles to each other, but both perpendicular to an imaginary axis (as when an orange is quartered); or by simultaneously-formed septa, which cut-off portions in such a manner, that the new cells stand in the position of cannon balls piled into a pyramid (tetrahedrally). These new cells are the ‘special parent-cells of the pollen;’ and in each of these the entire protoplasmic contents secrete a series of layers, which, in the ordinary course, by the solution of the primary walls of the special parent-cells upon which they were applied, become the walls of free-cells, which constitute the simple ordinary pollen-cells. These subsequently increase in size, and their outer coat assumes its characteristic form and appearance, while free in the chamber of the anther.”*

This history bears a very close parallel with that of the development of the spores within the ‘theca’ of the Mosses (§ 217); and it is not a little curious that the layer of cells which lines the pollen-chambers, should exhibit, in a considerable proportion of plants, a strong resemblance in structure, though not in form, to the elaters of the *Marchantia* (Fig. 132). For they have in their interior a fibrous deposit; which sometimes forms a continuous spiral (like that in Fig. 157), as in *Narcissus*

* “Micrographic Dictionary,” p. 516

and *Hyosciamus*; but is often broken-up, as it were, into rings, as in the *Iris* and *Hyacinth*; in many instances, forms an irregular net-work, as in the *Violet* and *Saxifrage*; in other cases, again, forms a set of interrupted arches, the fibres being deficient on one side, as in the yellow *Water-lily*, *Bryony*, *Primrose*, &c.; whilst a very peculiar stellate aspect is often given to these cells, by the convergence of the interrupted fibres towards one point of the cell-wall, as in the *Cactus*, *Geranium*, *Madder*, and many other well-known plants. Various intermediate modifications exist; and the particular form presented, often varies in different parts of the wall of one and the same anther. It seems probable that, as in *Hepaticæ*, the elasticity of these spiral cells may have some share in the opening of the pollen-chambers and the dispersion of the pollen-grains.

253. The form of the Pollen-grains seems to depend in part upon the mode of division of the cavity of the parent-cell into quarters; generally speaking it approaches the spheroidal, but it is sometimes elliptical, and sometimes tetrahedral. It varies more, however, when the pollen is dry, than when it is moist; for the effect of the imbibition of fluid, which usually takes-place when the pollen is placed in contact with it, is to soften-down angularities, and to bring the cell nearer to the typical sphere. The pollen-cell (save in a few submerged plants) has a thick outer coat, surrounding a thin interior wall, and this often exhibits very curious markings, which seem due to an increased thickening at some points, and a thinning-away at others. Sometimes these markings give to the surface-layer so close a resemblance to a stratum of cells, (Fig. 189, B, C, D), that only a very careful examination can detect the difference. The roughening of the surface by spines or knobby protuberances, as shown at A, is a very common feature; and this seems to answer the purpose of enabling the pollen-grains more readily to hold to the surface whereon they may be cast. Besides these and other inequalities of the surface, most pollen-grains have what appear to be pores or slits in the outer coat, varying in number in different species, through which the inner coat protrudes itself, when the bulk of its contents has been increased by imbibition; it seems probable, however, that the outer coat is not absolutely deficient at these points, but is only thinned away. Sometimes the pores are covered by little disk-like pieces, or lids, which fall-off when the pollen-tube is protruded. This action takes-place naturally, when the pollen-grains fall upon the

surface of the 'stigma,' which is moistened with a viscid secretion; and the pollen-tubes, at first mere protrusions of the

FIG. 189.

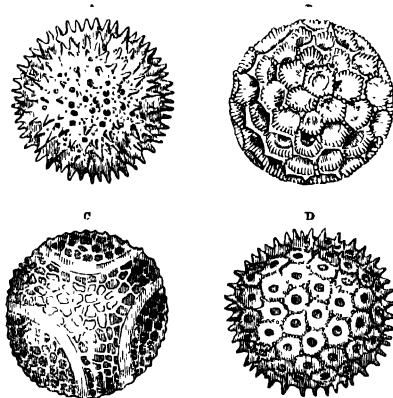

Pollen grains of,—A, *Althæa rosea*; B, *Cobæa scandens*; C, *Passiflora cærulea*; D, *Ipomæa purpurea*.

inner coat of their cell, insinuating themselves between the loosely-packed cells of the stigma, grow downwards through the 'style,' sometimes even to the length of several inches, until they reach the ovarium. The first change—namely, the protrusion of the inner membrane through the pores of the exterior—may be made to take-place artificially, by moistening the pollen with water, tin

syrup, or dilute acids (different kinds of pollen-grains requiring a different mode of treatment); but the subsequent extension by growth will only take-place under the natural conditions.

25 f. The darker kinds of pollen may be best mounted for the Microscope in Canada balsam; but this renders the more transparent kinds too faintly distinguishable; and it is better to mount them either dry, or (if they will bear it without rupturing) in fluid. The most delicate and interesting forms are found, for the most part, in plants of the Natural families *Amarantaceæ*, *Cichoraceæ*, *Cucurbitaceæ*, *Malvaceæ*, and *Passifloræ*; others are furnished also by *Convolvulus*, *Campanula*, *Ænothea*, *Pelargonium* (Geranium), *Polygonum*, *Sedum*, and many other plants. It is frequently preferable to lay-down the entire anther with its adherent pollen-grains (where these are of a kind that hold to it), as an opaque object; this may be done with great advantage in the case of the common Mallow (*Malva sylvestris*) or of the Hollyhock (*Althæa rosea*); the anthers being picked soon after they have opened, whilst a large proportion of the

pollen is yet undischarged, and before they have begun to wither, being laid down as flat as possible between two pieces of smooth blotting-paper, then subjected to moderate pressure, and finally mounted upon a black surface. They are then, when properly illuminated, most beautiful objects for the 2 in. objective.

255. The structure and development of the *Ovules* that are produced within the ovarium at the base of the pistil, and the operation in which their fertilization essentially consists, are subjects of investigation which have a peculiar interest for scientific Botanists, but which, in consequence of the special difficulties that attend the enquiry, are not commonly regarded as within the province of amateur Microscopists.—The ovule, in its earliest condition, is, like the anther, a mass of cells, in which no part is differentiated from the rest; gradually, this body, which is termed the *nucleus*, is found to be enveloped in one, two, or three coats, which are formed by the multiplication of cells that at first constitute merely an annular enlargement at its base; these coats, however, do not entirely close-in around the nucleus, at the point of which a small aperture always remains, that is called the *micropyle*. In the interior of the nucleus a large cavity is formed, apparently by the enlargement of one of its cells at the expense of those which surround it; and this cavity, which is called the *embryo-sac*, is at first filled only with a liquid protoplasm. Some little time before fecundation, however, there are seen in it a certain number of free cell-nuclei, rarely fewer than three, and frequently more; around these, free cells of a spheroidal form are developed, which are 'germ-cells,' of which one only, the *embryonal vesicle*, is ordinarily destined to be fertilized. This act is accomplished by the penetration of the pollen-tube, which, when it has made its way down to the ovarium, enters the 'micropyle' of the ovule, and impinges upon the apex of the 'embryo-sac,' which it sometimes pushes before it, in such a manner as to have given origin to the idea that the tube enters its cavity: no such penetration, however, really exists. By Prof. Schleiden, and his disciple Schacht, it is affirmed that the embryo makes its first appearance within the dilated extremity of the pollen-tube, which speedily becomes filled with a mass of cells; but nearly all other Vegetable Physiologists who have examined the question with sufficient care, have come to a different conclusion,—namely, that the embryo is the product of a cell-multiplication within the 'embryonal vesicle,' which seems to be fertilized by the transudation of the contents of

the pollen-tube, just as the embryonal vesicle within the archegonium of the Ferns is fertilized by the contact of the antherozoids (§ 219).

256. The early processes of development, too, correspond closely with those which have been described as taking place through the whole of the inferior tribes; for the primordial cell that is formed within the embryonal vesicle as the result of its fecundation, gives origin by transverse fission to a pair; this again, to four; and so on, it being usually in the terminal cell of the filament so generated, that the process of multiplication chiefly takes place, as in the *Confervæ* (§ 198). The filament then begins to enlarge at its lower extremity, where its cells are often multiplied into a somewhat globular mass; of this mass, by far the larger proportion is destined to be evolved into the 'cotyledons,' or seed-leaves, whose function is limited to the earliest part of the life of the young plant; the small remainder is the rudiment of the 'plumula,' which is to be developed within the stem and leaves; while the prolonged extremity of the embryonic filament, which is directed towards the micropyle, is the original of the 'radicle' or embryonic root — The mucilaginous protoplasm filling the 'embryo-sac,' in which the 'embryonal vesicle' was imbedded, becomes converted, by the formation of free cells, soon after fecundation, into a loose cellular tissue, which constitutes what is known as the 'endosperm;' this, however, usually deliquesces again, as the embryonic mass increases in bulk and presses upon it; and its development is of interest, chiefly because it may be shown, by the curious intermediate phase presented by the *Lycopodiaceæ* and *Conifereæ* (§ 221), that this endosperm is the equivalent of the 'prothallium' of the higher Cryptogamia *

257. In tracing the origin and early history of the Ovule, very thin sections should be made through the flower-bud, both vertically and transversely; but when the ovule is large and distinct enough to be separately examined, it should be placed on the thumb-nail of the left hand, and very thin sections made with a sharp razor; the ovule should not be allowed to dry-up, and the sections should be removed from the blade of

* For a more detailed account of the Generative process in ordinary Phanerogamia and in *Conifereæ*, as well as for references to the principal original sources of information on this controverted question, the Author may be permitted to refer to his "Principles of Comparative Physiology," 1th Ed., §§ 501-505. Some recent discussion on the same subject will be found in the "Ann. des Sci. Nat.," 4ième Sér., tom. III. pp. 188 et seq.

the razor by a wetted camel-hair pencil. The tracing-downwards the pollen-tubes through the tissue of the style, may be accomplished by sections (which, however, will seldom follow one tube continuously for any great part of its length), or, in some instances, by careful dissection with needles. Plants of the *Orchis* tribe are the most favourable subjects for this kind of investigation, which is best carried-on by artificially applying the pollen to the stigma of several flowers, and then examining one or more of the styles daily. "If the style of the flower of an *Epipactis* (says Schacht), to which the pollen has been applied about eight days previously, be examined in the manner above mentioned, the observer will be surprised at the extraordinary number of pollen tubes, and he will easily be able to trace them in large strings, even as far as the ovules. *Viola tricolor* (heartsease) and *Ribes nigrum* and *rubrum* (black and red currant) are also good plants for the purpose, in the case of the former plant, withered flowers may be taken, and branched pollen-tubes will not unfrequently be met-with." The entrance of the pollen-tube into the micropyle may be most easily observed in *Orchideous* plants and in *Euphrasia*, it being only necessary to tear-open with a needle the ovary of a flower which is just withering, and to detach from the placenta the ovules, almost every one of which will be found to have a pollen-tube sticking in its micropyle. These ovules, however, are too small to allow of sections being made, whereby the origin of the embryo may be discerned; and for this purpose, *Enothera* (evening-primrose) has been had-recourse-to by Hoffmeister, whilst Schacht recommends *Lathraea squamaria*, *Pedicularis palustris*, and particularly *Pedicularis sylvatica*—There is no kind of investigation that requires nicer management, and none which is just now of greater interest to Botanists. Such Microscopists, therefore, as have qualified themselves for the enquiry, by their acquirement of the knowledge which is requisite to guide their dissections, and of the manipulative skill by which alone these dissections can be successfully made, cannot do a greater service to science, than by applying themselves perseveringly to it. The use of high magnifying powers is not at all needed. Much may be done, in the preparation of the objects, under the Simple microscope; and for the examination of the preparations, a power of 200 diameters with a shallow eyepiece is generally sufficient. The assistance of the Binocular Microscope would probably be found peculiarly valuable in

this enquiry ; since the right *interpretation* of the appearances presented, mainly depends upon a precise knowledge of the exact relative position of the pollen-tube, embryo-sac, &c., such as this instrument is peculiarly fitted to convey.

258. We have now, in the last place, to notice the chief points of interest to the Microscopist, which are furnished by mature *Seeds*. Many of the smaller kinds of these bodies are very curious, and some are very beautiful, objects, when looked-at in their natural state, under a low magnifying power. Thus the seed of the *Poppy* (Fig. 190, A) presents a regular

FIG. 190.

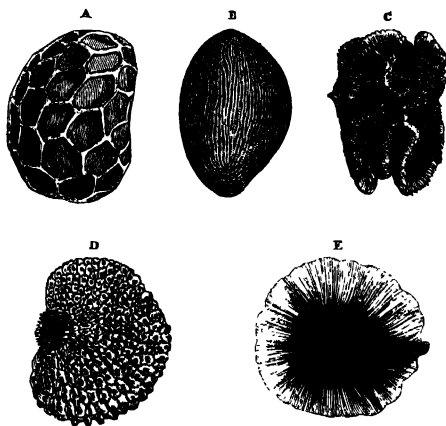

Seeds, as seen under a low magnifying power :—A, *Poppy*; B, *Amaranthus* (Prince's feather); C, *Antirrhinum majus*? (Snapdragon); D, *Caryophyllum* (Clove-pink); E, *Bignonia*.

reticulation upon its surface, pits, for the most part hexagonal, being left between projecting walls, that of *Caryophyllum* (D) is regularly covered with curiously-jagged divisions, every one of which has a small bright black hemispherical knob in its middle; that of *Amaranthus hypochondriacus* has its surface traced with extremely delicate markings (B); that of *Antirrhinum* (?) is strangely-irregular in shape (C), and looks almost like a piece of furnace-slag ; and that of *Bignonia*

(E) is remarkable for the beautiful structure of the translucent membrane which surrounds it, the radiating lines shown in the figure being found under a higher magnifying power to consist of rows of elongated spiral cells. Such are seen, too, in the like delicate membrane that surrounds several other seeds, as those of *Sphenogyne speciosa* and *Lophospermum erubescens*, which, from possessing this appendage, are spoken of as 'winged.' The most remarkable development of this structure is said by Mr. Quekett to exist in a seed of *Calos-anthes Indica*, an East Indian plant, in which the wing extends more than an inch on either side of the seed. Some seeds are distinguished by a peculiarity of form, which, although readily discernible by the naked eye, becomes much more striking when they are viewed under a very low magnifying power; this is the case, for example, with the seeds of the *Carrot*, whose long radiating processes make it bear, under the Microscope, no trifling resemblance to some kinds of star-fish; and with those of *Cyanthus minor*, which bear about the same degree of resemblance to shaving-brushes. In addition to the preceding, the following may be mentioned as seeds easily to be obtained, and as worth mounting for opaque objects:—*Anagallis*, *Anethum graveolens*, *Antirrhinum*, *Begonia*, *Carum carvi*, *Coriopsis tinctoria*, *Datura*, *Delphinium*, *Digitalis*, *Elatine*, *Erica*, *Gentiana*, *Gesneria*, *Hyoscyamus*, *Hypericum*, *Lepidium*, *Limnorcharis*, *Linaria*, *Lycchnis*, *Mesembryanthemum*, *Nicotiana*, *Orobanche*, *Petunia*, *Reseda*, *Saxifraga*, *Scrophularia*, *Sedum*, *Sempervivum*, *Silene*, *Stellaria*, and *Verbena*. The following may be mounted as transparent objects in Canada balsam:—*Drosera*, *Hydrangea*, *Monotropus*, *Orchis*, *Parnassia*, *Pyrola*, *Saxifraga*.* The seeds of Umbelliferous plants generally are remarkable for the peculiar *vitta*, or receptacles for essential oil, which are found in their coats. Various points of interest respecting the structure of the *testæ* or envelopes of seeds,—such as the fibre-cells of *Cobaea* and *Collomia*, the stellate cells of the *Star-Anise*, and the densely-consolidated tissue of the 'shells' of the *Coquilla-nut*, *Cocoa-nut*, &c.,—having been already noticed, we cannot here stop to do more than advert to the peculiarity of the constitution of the 'husk' of the *Corn-grains*. In these, as in other Grasses, the ovary itself continues to envelope the seed, forming a covering to it, that surrounds its own testa; this

* These lists have been chiefly derived from the "Micrographic Dictionary," p. 572.

covering (which forms the 'bran' that is detached in grinding) is composed of hexagonal cells of remarkable regularity and density; and these are so little altered by a high temperature, as still to be readily distinguishable when the grain has been ground after roasting,—thus enabling the Microscopist to detect even a very small admixture of roasted Corn with Coffee or Chicory, without the least difficulty.*

* In a case in which the Author was called-upon to make such an investigation, he found as many as *thirty* distinctly-recognizable fragments of this cellular envelope, in a *single grain* of a mixture consisting of Chicory with only 5 per cent. of roasted Corn.

CHAPTER IX.

MICROSCOPIC FORMS OF ANIMAL LIFE:—PROTOZOA;
ANIMALCULES.

259. *Protozoa*—Passing-on, now, to the Animal Kingdom, we begin by directing our attention to those minute and simple forms, which correspond, in the Animal series, with the Protophyta in the Vegetable (Chap VI); and this is the more desirable, since the formation of a distinct group, to which the name of *Protozoa* (first proposed by Siebold) may be appropriately given, is not merely one of the most interesting results of recent Microscopic enquiry, but is a subject on which it is particularly important that the Microscopic observer should know what the Physiologist believes himself to have ascertained. This group, which must be placed at the very base of the animal scale, beneath the great sub-kingdoms marked-out by Cuvier, is characterized by the extreme simplicity that prevails in the structure of the beings composing it; these being either *isolated cells*, or *aggregations of cells* wherein no such differentiation of parts exhibits itself, as constitutes the 'organs' of even the simplest Zoophyte or Worm—We have in the first place to consider, therefore, what are the essential characters of the Animal cell; and what are the precise relations of the Protozoa to the Protophyta, to which they seem to bear so close an affinity.

260. The Animal Cell, in its most complete form, is comparable in most parts of its structure to that of the Plant; but differs from it in the entire absence of the 'cellulose-wall,' or of anything that represents it, the cell-contents being enclosed in only a single unitary membrane, the chemical composition of which (being albuminous) indicates its correspondence with the primordial utricle (§ 117). In its young state, it seems always to contain a semi-fluid *plasma*, which is essentially the same as the 'protoplasm' of the Plant, save that it does not include chlorophyll-granules; and this may either continue to occupy its cavity (which is the case in cells whose entire energy is directed to growth and multiplication), or

may give place, either wholly or in part, to the special product which it may be the function of the cell to prepare. Like the Vegetable cell, that of Animals very commonly multiplies by duplicative subdivision; and it also (especially among Protozoa) may give origin to new cells, by the breaking-up of its contents into several particles; but new cells are not unfrequently to be met-with, especially in the nutritive fluids of such Animals as possess a distinct circulation, which have not directly originated in either of these modes from a previously existing cell, but which have been developed by a process of *free* cell-formation, namely, by the aggregation of organic molecules, floating in these fluids, into little masses, of which the external particles coalesce into a membranous cell-wall, whilst the interior liquefy into cell-contents. This can only take-place, however, in a liquid which has undergone elaboration in the interior of a highly-organized living body; and we find no traces of such free cell-formation among the members of the group we are first to investigate.

261. As we have seen (§ 150) that, among the lowest Protophytes, the general attributes of a cell may exist in a minute mass of protoplasm which is not bounded by a limitary membrane,—the differentiation between cell-wall and cell-contents not having yet manifested itself,—so, among the lowest *Protozoa*, we find the power of maintaining an independent existence to be possessed by similar particles of that peculiar *blastema*, or formative substance, to which the name of *sarcodé* has been given by Dujardin (who first drew attention to its extraordinary endowments), and which may be considered as the basis, not merely of the entire organisms of Protozoa, but of a large part of that of higher animals. The properties of this may be most fully understood by the careful study of a creature, which is by no means unfrequently to be met-with in fresh and stagnant waters, vegetable infusions, &c.; and which, from the great variety of forms it assumes, has received the designation of *Protéus*. This name, however, having been assigned to an animal of far higher organization, that with which we are now concerned is properly known as the *Amœba* (Fig. 191). It may be described as a minute mass of 'sarcodé,' presenting scarcely any evidence of distinct organization, even of the simplest kind; for, as in the lowest forms of Vegetable cell (§ 148), there is not even a complete differentiation between the cell-wall and the cell-contents; the former not being composed of a distinct membrane, though obviously possessing more consistence than the latter, which

are semi-fluid. A contractile vesicle (or rather, perhaps, a 'vacuole') may be observed in some part of the body, which pulsates at tolerably-regular intervals; and 'vacuoles' or clear spaces are seen, surrounding the alimentary particles which have been received into the midst of the jelly-like substance. However inert and shapeless this minute body may be when first noticed, its possession of vital activity is soon made apparent by the movements which it executes, and by

FIG. 191.

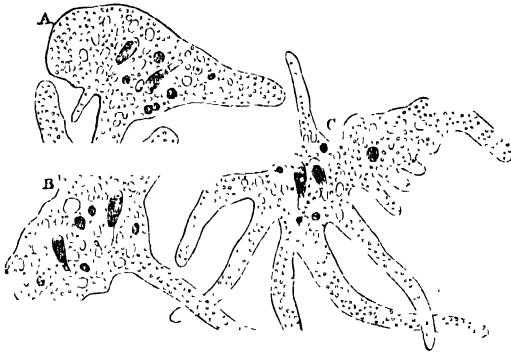

Amœba princeps, in different forms, A, B, C.

the changes of form which it undergoes; these being, in fact, part of one and the same set of actions. For the shapeless mass puts-forth one or more finger-like prolongations, which are simply extensions of its gelatinous substance in those particular directions; and a continuation of the same action, first distending the prolongation, and then (as it were) carrying the whole body into it, causes the entire mass to change its place. After a short time another prolongation is put forth, either in the same or in some different direction; and the body is again absorbed into it. These changes seem to be connected with a movement of the semi-fluid particles in the interior of the mass, of which a current may be observed to 'set' in the direction wherein the protrusion is about to take place, *before* the surface shows any projection.—When the

creature, in the course of its progress, meets with a particle capable of affording it nutriment, its gelatinous body spreads itself over or around this, so as to envelope it completely; and the substance (sometimes animal, sometimes vegetable) thus taken into this extemporized stomach, undergoes a sort of digestion there, the nutrient material being extracted, and any indigestible part making its way to the surface and finally being (as it were) squeezed-out.—Of the mode of reproduction of *Amœba*, nothing is yet known, save that it undergoes multiplication by self-division, very much in the manner of the Protophytes, and that portions separated from the jelly-like mass, either by cutting or tearing, can develop themselves into independent beings. Consequently, as we are quite in the dark respecting the sexual operation, which (as all analogy would lead us to believe) must take-place at some period of its life, it cannot be said that we are acquainted with more than one phase of its existence; and it is quite possible that, after many repetitions of the process of multiplication by self-division, some entirely-new form may present itself, of which the *Amœba* is (as it were) the larva. The completion of the life-history of this curious creature, therefore, is a most worthy object of Microscopic enquiry; and its abundance in many situations should prevent this from being a matter of any great difficulty to an observer, who can devote sufficient attention to the study.*

262. Nearly allied to the preceding, is another curious organism, on which the attention of many eminent Microscopists has been recently fixed. This creature, the *Actinophrys* (Fig. 192), consists like the preceding of a homogeneous, jelly-like, contractile substance, or *sarcode*, not enclosed in any distinct envelope, though the outer portion seems to be of firmer consistence than the inner. Throughout the body, which is usually nearly spherical in form, but more particularly near its surface, there are observed vacuoles occupied by fluid; these

* It has been recently affirmed by Dr Hartig, that *Amœbæ* may be produced by the transformation of the 'antherozoids' of Chara (§ 202), Marchantia, or Mosses, and that, in their turn, they become metamorphosed, first into Protozoeci or other unicellular Alga, and then into Articulated Alga. But even if jelly-like bodies resembling *Amœbæ* in general appearance and in spontaneous change of form, should be thus produced, they cannot be said to be true *Amœbæ*, unless they should feed in the manner described above,—which Dr. Hartig does not appear to have witnessed. (See "Quart. Journ. of Microsc. Science," vol. iii. p. 51.)—However strange Dr Hartig's statements may be, they are not more strange than many assertions of the same class first appeared, which are now admitted as unquestionable truths, and they ought not to be set aside without disproof, any more than they should be received without further confirmation.

have no definite boundaries, and may be easily made artificially either to coalesce into larger ones, or to subdivide into smaller. A 'contractile vesicle' (*o*), pulsating rhythmically with great regularity, is always to be distinguished either in the midst of the jelly-like substance, or (more commonly) near its surface; and the appearance which it presents in this latter position, seems to leave no doubt of its being included within a distinct though very thin membrane. The 'sarcode' extends itself into contractile tentacular filaments, which are called *pseudopodia*; and these, in the *Actinophrys sol*, are commonly seen to radiate from the centre, in such a manner as to have suggested the designation of the species. Their degree of extension, how-

FIG. 102.

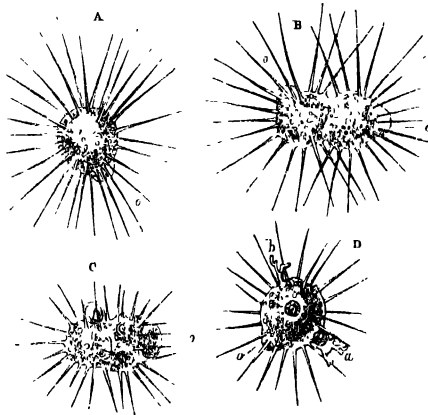

Actinophrys sol in different states —A, in its ordinary sun-like form, with a prominent contractile vesicle, *o*; B, in the act of division or of conjugation, with two contractile vesicles, *o, o*; C, in the act of feeding, D, in the act of discharging faecal (?) matters, *a* and *b*.

ever, is extremely variable, and sometimes they entirely disappear: the creature cannot then be distinguished with certainty from an Amœba. For although the form of the latter is generally flattened, yet it sometimes becomes nearly spherical; so that neither type can be recognized, until the jelly-like spherule flattens itself out as an Amœba, or puts forth radiating 'pseudopodia' as an Actinophrys.—Far less

activity is exhibited by *Actinophrys*, than by *Amœba*; and the slight change of place which it undergoes from time to time, does not seem attributable either to any change of form of the body, or to any bending of the tentacles. It is by the agency of these, however, that its nourishment is obtained; and this is derived not merely from vegetable particles, but from various small animals, some of them (as the young of Crustaceans) possessing great activity, as well as a comparatively high organization. When any of these happens to come into contact with one of the tentacular filaments, this usually retains it by adhesion, and forthwith begins to retract itself; as it shortens, the surrounding filaments also apply themselves to the captive particle, bending their points together so as gradually to enclose it, and themselves retracting, until the prey is brought close to the surface of the body. The threads of 'sarcodæ' of which the 'pseudopodia' are composed, not being invested (any more than the sarcodæ of the body) by any limiting membrane, coalesce with each other and with it; and thus the particle which has been entrapped by them becomes actually embedded in the gelatinous mass, and gradually passes from the peripheral towards the central part of it, where its digestible portion undergoes solution, the superficial part of the body, with its pseudopodial prolongations, in the mean time recovering their previous condition. Any indigestible portion, as the shell of a Crustacean, or the hard case of a Rotifer, finds its way to the surface of the body; and is extruded from it by a process exactly the converse of that by which it is drawn-in (Fig. 192, *d*). The number as well as the size of the particles included by the *Actinophrys* at any one time is very various; frequently they are more than ten or twelve. They are not usually embraced closely by the sarcodæ, but are surrounded by fluid in 'vacuoles' in its substance; and it was this appearance which led Prof. Ehrenberg to describe the animalcule as possessing numerous stomachs.—The *Actinophrys*, like the *Amœba*, multiplies itself by self-division; but a process which seems to resemble the 'conjugation' of Protophytes (§ 151), has also been witnessed in it by Prof. Kolliker and Dr. Cohn. Two individuals approximate and coalesce, so as to form what appears to be a single body; but a 'nucleus' then makes its appearance, which gradually develops itself into a mass having the characters of its parent; and the young *Actinophrys* thus generated probably escapes before long from the body within which it originated. As the condition of an *Actinophrys* undergoing

self-division is to all appearance the same as that of two individuals in incipient conjugation (Fig. 192, B), it cannot be determined in any particular case which operation is in progress, until the creature has been watched sufficiently long for the *tendency* of its changes to become apparent.

263. If, now, we compare the foregoing history with that of *Palmoglaea* or any other simple Protophyte, we shall see that whilst there is a strong analogy between the two sets of phenomena, there are at the same time certain most important differences. One of the most obvious of these differences, lies in the *movements* exhibited by the *Amoeba* and *Actinophrys*; for although these are by no means sufficient in themselves (as was once supposed) to establish the distinction between the Animal and Vegetable kingdoms, yet, when they do not consist in the mere vibrations of cilia, such as are executed by zoospores, antherozoids, &c., among Plants, but depend upon alterations in a contractile substance forming the entire body, they bear a much closer resemblance to the actions of higher Animals; and we may trace in fact, in the ascending Animal scale, a progressive specialization or setting-apart of certain portions of the contractile substance more peculiarly endowed with this property, until they take the form of distinct muscular bands.—A more positive and easily-defined distinction lies in the *nature of the aliment* of the Protophyta and Protozoa respectively, and in the *method of its introduction*. For whilst the Protophyte obtains the materials of its nutrition from the air and moisture that surround it, and possesses the power of detaching oxygen, hydrogen, carbon, and nitrogen from their previous binary combinations, and of uniting them into ternary, and quaternary organic compounds (chlorophyll, starch, albumen, &c.), the simplest Protozoon, in common with the highest members of the Animal kingdom, seems utterly destitute of any such power, and is dependent for its support upon organic substances previously elaborated by other beings. But further, the Protophyte obtains its nutriment by mere absorption of liquid and gaseous molecules, which penetrate by simple imbibition; whilst the Protozoon, though destitute of any proper stomach, makes (so to speak) a stomach for itself in the substance of its body, into which it ingests the solid particles that constitute its food, and within which it subjects them to a regular process of digestion.—Hence these simplest members of the two kingdoms, which can scarcely be distinguished from each other by any *structural* characters, seem to be *physiologically* separable by the mode in which

they perform those actions wherein their life most essentially consists; for the *Protococcus*-cell decomposes carbonic acid under the influence of light, and generates chlorophyll and proteine-compounds, in a manner in all respects comparable to that in which the same operation is performed by the leaf-cells of the most perfect Plant; whilst the *Amœba* ingests and digests both Vegetable and Animal food, and applies it to the nutrition of its body, no less effectively than an Animal possessing the most complex digestive and circulating apparatus. And in the present state of our knowledge, we seem justified in laying it down as the most ready and certain differential character we are acquainted-with, between the most closely-related *Protophyta* and *Protozoa*, that the former (with the exception of the *Fungi*) decompose carbonic acid under the influence of light, and acquire a red or green colour from the new compounds which they form in their interior; whilst the latter, having no such power,* receive animal and vegetable organisms, or particles of such, into the interior of their bodies, where they extract from them the ready-prepared nutriment they are fitted to yield.

264. *Rhizopoda*.—The two creatures above described as the types of the simplest form of Protozoic life, are not now regarded as Infusory Animalcules, among which they were ranked by Prof. Ehrenberg; but are considered as the types of a distinct subdivision, to which the name of *Rhizopoda* has been assigned by M. Dujardin; this name very appropriately representing the leading feature in their organization, which consists in the extension of their sarcode-body into long root-like processes, whereby their aliment is drawn into its substance. In by far the larger proportion of the animals included in this group, a *carapace* or shell is formed, either by the consolidation of the superficial layer of the sarcode-body through impregnation of its substance with mineral matter, or (as appears to be the case in some instances) by the agglutination of particles of sand, &c., with a viscid secretion exuded from its surface. This 'carapace,' in *Arcella* (Fig. 193, c, d), has for its basis a layer of dense membrane, which seems analogous to the firm envelope of the *Desmidiaceæ* (§ 164), and to that which constitutes the basis of the 'lorica' of *Diatomaceæ* (§ 172); and in some species it sends-out

* Many instances have been cited, of *Animalcules* acquiring a green colour by the decomposition of carbonic acid under the influence of light; but there can be no doubt in the mind of any one who is familiar with the results of recent microscopic research, that in all these cases, the supposed *Animalcules* were really *Protophytes*.

spinous prolongations like those of the former; whilst in others its surface exhibits symmetrical markings that resemble those of the latter. Its material differs, however, from that of the cellulose wall of Vegetable cells, as may be shown by the effects of reagents; and seems to be rather a modification of horny matter, probably resembling the *chitine* which gives solidity to the integuments of Insects. Not unfrequently it contains particles of sand, minute Diatoms, &c., imbedded in its substance. The *Diffugia* (Fig. 193, A, B) differs in no

FIG. 193.

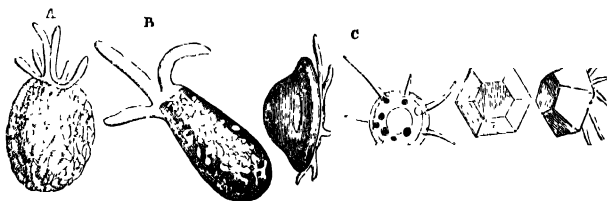

Various forms of Simple Rhizopods —A, *Diffugia proteiformis*;
B, *Diffugia oblonga*. C, *Arcella acuminata*. D, *Arcella dentata*.

essential particular from *Arcella*, save in the form of its carapace, which is pitcher-shaped, instead of being shield-like or dish-shaped. In the one case, as in the other, the carapace has but a narrow opening, through which alone can the 'pseudopodia' be projected. The general nature of these animals seems to be exactly the same as that of *Amœba* and *Actinophrys*; and their mode of nutrition differs only in this, that their food can only be drawn into that part of the body which is unprotected by the carapace. Nothing positive is yet known as to their Reproduction. Two individuals may not unfrequently be seen with the apertures of their shells in contact with each other, the pseudopodial prolongations being apparently common to both; but whether these are in the act of conjugation, or whether (as the younger aspect of one of the shells sometimes indicates) the union results from the production of a bud not yet separated, cannot yet be certainly affirmed.—The most remarkable development of this type of organization presents itself among the marine *Foraminifera* and *Sponges*; in which composite structures, often of very large size, are developed by continuous gemmation, and a

complex skeleton is produced. These, not being in themselves (for the most part at least) *microscopic* organisms, will be more fitly considered under a separate head (Chap. x.).

265. *Animalcules*.—Dismissing the Rhizopods for the present, we have now to apply ourselves to the special subject of this chapter; namely, the assemblage of minute forms of Animal life, which are commonly known under the designation of Animalcules. Nothing can be more vague or inappropriate than this title, since it only expresses the small dimensions of the beings to which it is applied, and does not indicate any of their characteristic peculiarities. In the infancy of Microscopic knowledge, it was natural to associate-together all those creatures which could only be discerned at all under a high magnifying power, and whose internal structure could not be clearly made-out with the instruments then in use; and thus the most heterogeneous assemblage of Plants, Zoophytes, minute Crustaceans (water-fleas, &c.), larvæ of Worms and Mollusks, &c., came to be aggregated with the true Animalcules under this head. The class was being gradually limited by the removal of all such forms as could be referred to others; but still very little was known of the real nature of those that remained in it, until the study was taken-up by Prof Ehrenberg, with the advantage of instruments which had derived new and vastly-improved capabilities from the application of the principle of Achromatism (p. 18). One of the first and most important results of his study, and that which has most firmly maintained its ground notwithstanding the weakening of Prof. Ehrenberg's authority in other respects, was the separation of the entire assemblage into two distinct groups, having scarcely any feature in common excepting their minute size, one being of very *low*, and the other of comparatively *high* organization. On the lower group he conferred the designation of *Polygastrica* (many-stomached), in consequence of having been led to form an idea of their organization, which the united voice of the most trustworthy observers now pronounces to be erroneous; and he not only assigned to them a complex digestive apparatus, but considered them to be endowed with genital organs, nervous ganglia, and organs of special sense, for none of which can any adequate basis be found in the appearances that the Microscope brings into view within their bodies. Hence it seems desirable to abandon the term '*Polygastrica*,' as conveying an erroneous idea of the structure of these beings; and we may appropriately fall-back on the name *Infusoria*, or Infusory Animalcules,

which simply expresses their almost universal prevalence in infusions of organic matter. For although this was applied by the older writers to the higher group as well as to the lower, yet as these are now distinguished by an appropriate appellation of their own, and are, moreover, *not* found in infusions when in that state of rapid decomposition which is most favourable to the presence of the inferior kind of Animalcules, it may very well be withdrawn from them, and be restricted to the Polygastrica of Ehrenberg, which is the sense wherein it has been used by many recent writers.—To the higher group, Prof. Ehrenberg's name *Rotifera* or *Rotatoria* is on the whole very appropriate, as significant of that peculiar arrangement of their cilia upon the anterior parts of their bodies, which, in some of their most common forms, gives the appearance (when the cilia are in action) of wheels in revolution; the group, however, includes many members, in which the ciliated lobes are so formed as not to bear the least resemblance to wheels. In their general organization, these 'Wheel-animalcules' must certainly be considered as members of the *Articulated* division of the Animal Kingdom; and they seem to constitute a class in that lower portion of it, to which the designation *Worms* is now commonly given.—Notwithstanding this wide zoological separation between the two kinds of Animalcules, it seems most suitable to the plan of the present work, to treat of them in connection with one another; since the Microscopist continually finds them associated together, and almost necessarily ranges them in his own mind under one and the same category.

266. *Infusoria*.—This term, as now limited by the separation of the *Rotifera*, is applied to a far smaller range of forms than that which was included by Prof. Ehrenberg under the name of 'polygastric' animalcules. For a large section of these, including the *Desmidiaceæ*, *Diatomaceæ*, *Volvocineæ*, and many other Protophytes, have been transferred by the almost concurrent voice of those Naturalists whose judgment is most to be relied-on, to the Vegetable Kingdom. The *Rhizopod* group, again, must be excluded, as being very distinct in its plan of organization from the true *Infusoria*. And, lastly, it is not improbable that many of the reputed *Infusoria* may be but larval forms of some higher organisms, instead of being themselves complete animals.* Still an extensive group

* Professor Agassiz, indeed, goes so far as to assert ("Ann. of Nat. Hist.," vol. II., 1850, p. 157) that, as he has satisfied himself by direct observation, *Bursaria*, *Paramicum*, and other Animalcules which are commonly ac-

remains, of which no other account can at present be given, than that the beings of which it is composed go through the whole of their lives, so far as we are acquainted with them, in the condition of isolated cells; differing from Vegetable cells on the one hand, and from Rhizopods on the other, in this remarkable particular,—that the alimentary particles by which they are nourished are taken into their cavity through a distinct oral aperture, some of them also having an anal orifice for the ejection of indigestible matters. It has been imagined by Prof. Ehrenberg, that a distinct alimentary canal exists; sometimes returning upon itself (as in *Vorticella*), sometimes proceeding straight from one extremity of the body to the other (as in *Enchelis*), and sometimes passing round and round in a spiral (as in *Leucophrys*), having a number of flask-shaped stomachs connected with it, into which the alimentary particles find their way, and in which they undergo digestion. But as he made the like assertions with regard to beings that have been since undoubtedly proved to belong to the Vegetable Kingdom, their authority must be explicitly denied; and all the best observers of the present time would agree (the Author believes) in the following general account of the organization of Infusoria.

267. Their bodies consist of 'sarcode,' of which the outer layer possesses considerably more consistence than the internal portion; the process of differentiation having here advanced sufficiently far to establish a clear distinction between the *wall* and its *contents*. Sometimes, as in *Paramecium*, a distinct pellicle may be recognized on the surface of the proper coat of the body; and this, which is studded with regularly-arranged markings like those of Diatomaceæ, seems to be the representative of the carapace of *Arcella*, &c. (§ 264), as of the cellulose coat of Protophytes. The form of the body is usually much more definite than that of *Amœba* or *Actinophrys*; each species having its characteristic shape, which is only departed from, for the most part, when the animalcule is subjected to pressure from without, or when its cavity has been distended by the ingestion of any substance above the ordinary size. The body does not seem to possess much contractile power in its own substance, its

counted as types of this group, are germs of fresh-water worms, some of which he has seen hatched from eggs of *Planaria*.—No confirmation has yet been given to this statement by other observers; and until details of these observations shall have been published, it cannot be expected that Zoologists should acquiesce in the entire demolition of this class, which Prof. Agassiz thinks himself warranted by them in proposing.

movements being principally executed by the instrumentality of locomotive appendages; one remarkable instance of contractility, however, is presented by the stalk of *Vorticella* (§ 268). The locomotive appendages, which may all be considered as prolongations of the tegumentary layer, are destitute of any more minute organization, being, in fact, of the nature of *cilia*, though sometimes of much larger dimensions, and employed in a different manner. The vibration of ciliary filaments, which are either disposed along the entire margin of the body, as well as around the oral aperture (Figs. 194, 195), or are limited to some one part of it, this being always in the

FIG. 194.

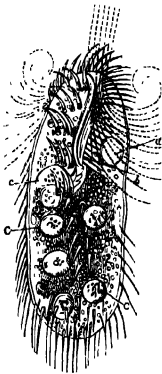

FIG. 195.

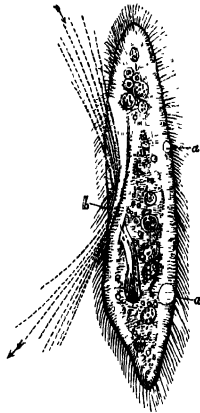

FIG. 194. *Kerona silurus* —*a*, contractile cavity; *b*, mouth; *c, c*, animalcules swallowed by the *Kerona*, after having themselves ingested particles of indigo.

FIG. 195. *Paramecium caudatum*:—*a a*, contractile cavities; *b*, mouth.

immediate vicinity of the mouth (Fig. 196), is the means by far the most frequently employed by the beings of this class, both for progression through the water, and for drawing alimentary particles into the interior of their bodies. In some their vibration is constant, whilst in others it is only occasional, thus conveying the impression that the Animalcule has a voluntary control over them; but there is strong reason for questioning the existence of any such self-directing power.

These cilia, like those of the zoospores of Protophytes, can usually be distinctly seen only when their movement is very much slackened in its rate, or when it has entirely ceased. Sometimes, however, instead of a multitude of short cilia, we find a small number of long slender filaments, usually proceeding from the anterior part of the body (that nearest the mouth), and strongly resembling the elongated cilia of Proto-coccus (Fig. 68, H) or of Volvox (Fig. 70, I, K, L). But in other cases, the filaments are comparatively short, and have a bristle-like firmness; and instead of being kept in vibration, they are moved (like the spines of Echini) by the contraction of the substance to which their bases are attached, in such a manner that the animalcule crawls by their means over a solid surface, as we see especially in *Trichoda lynceus* (Fig. 199, P, Q). In *Chilodon* and *Nassula*, the mouth is provided with a circle of these bristles, which have received the designation of 'teeth;' their function, however, is rather that of laying-hold of alimentary particles by their expansion and subsequent drawing-together (somewhat after the fashion of the tentacula of Zoophytes), than of reducing them by any kind of masticatory process.

268. The modes of movement which Infusory Animalcules execute by means of these instruments, are extremely varied and remarkable. Some propel themselves directly forwards, with a velocity which appears, when thus highly magnified, like that of an arrow, so that the eye can scarcely follow them, whilst others drag their bodies slowly along like a leech. Some attach themselves by one of their long filaments to a fixed point, and revolve around it with great rapidity, whilst others move by undulations, leaps, or successive gyrations; in short, there is scarcely any kind of animal movement which they do not exhibit. There is no sufficient reason, however, to regard such actions as indicative of consciousness; indeed, the very fact that they are performed by the instrumentality of *cilia* seems to imply the contrary; since we know that ciliary action takes place to a large extent in our own bodies, without the least dependence upon our consciousness, and that it is also used as a means of dispersion among the zoospores of the lowest Plants, which cannot for a moment be supposed to be endowed with this attribute. We can only regard it, therefore, as indicative of a wonderful adaptation, on the part of these simple ciliated cells, to a kind of life which enables them to go in quest of their own nutriment, and to introduce it when obtained into the interior of their bodies.

—The curious contraction of the footstalk of the *Vorticella*, however, is a movement of a very different nature, and is due to the contractility of the tissue that occupies the interior of the tubular pedicle. This stalk serves to attach the bell-shaped body of the Animalcule to some fixed object, such as the leaf or stem of duck-weed; and when the animal is in search of food, with its cilia in active vibration, the stalk is fully extended.

If, however, the Animalcule should have drawn to its mouth any particles too large to be received within it, or should be touched by any other that happens to be swimming near it, or should be 'jarred' by a smart tap on the stage of the microscope, the stalk suddenly contracts into a spiral, from which it shortly afterwards extends itself again into its previous condition. The central cord to whose contractility this action is due, has been

described as muscular; but it does not possess the characteristic structure of either kind of muscular fibre, and is probably nothing else than a portion of sarcode specially endowed with this property. Nothing but the rapidity of its contraction and relaxation differentiates it from the pseudopodia of the Rhizopods.—There is no reason whatever to believe that these Animalcules possess any organs of special sense. The red spots which may be seen in many of them, and which have been designated as eyes by Prof. Ehrenberg, from their supposed cor-

FIG. 196.

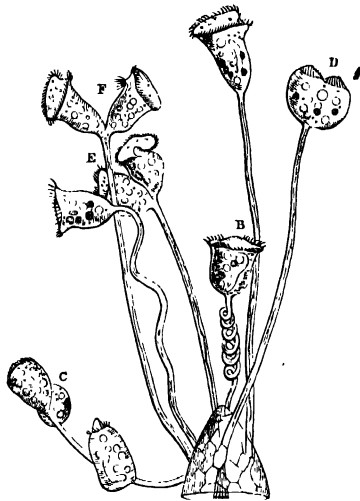

Group of *Vorticella nebulifera*, showing A the ordinary form, B the same with the stalk contracted; C the same with the bell closed; D, E, F, successive stages of fissiparous multiplication.

respondence with the eye-spots of *Rotifera* (§ 278), really bear a much greater resemblance to the red spots which are so frequently seen among Protophytes (§ 153). If they are really endowed with consciousness, as their movements *seem* to indicate, though other considerations render it very doubtful, they must derive their perceptions of external things from the impressions made upon their general surface, but more particularly upon their filamentous appendages.

269. The interior of the body does not always seem to consist of a simple undivided cavity, occupied by soft 'sarcodæ;' for the tegumentary layer appears in many instances to send prolongations across it in different directions, so as to divide it into chambers of irregular shape, freely communicating with each other, which may be occupied either by sarcodæ, or by particles introduced from without. The alimentary particles which can be distinguished in the interior of the transparent bodies of Infusoria, are usually Protophytes of various kinds, either entire or in a fragmentary state. The Diatomacæ seem to be the ordinary food of many; and the insolubility of their *loricæ* enables the observer to recognize them unmistakably. Sometimes entire Infusoria are observed within the bodies of others not much exceeding them in size (Fig. 199, B); but this is only when they have been recently swallowed, since the prey speedily undergoes digestion. It would seem as if these creatures do not feed by any means indiscriminately; since particular kinds of them are attracted by particular kinds of aliment; the crushed bodies and eggs of Entomostracea, for example, are so voraciously consumed by the *Coleps*, that its body is sometimes quite altered in shape by the distension. This circumstance, however, by no means proves, as some have considered it to do, that such creatures possess a sense of taste and a power of determinate selection; for many instances might be cited, in which actions of the like apparently-conscious nature are performed without any such guidance.—The ordinary process of feeding, as well as the nature and direction of the ciliary currents, may be best studied by diffusing through the water containing the Animalcules, a few particles of indigo or carmine. These may be seen to be carried by the ciliary vortex into the mouth, and their passage may be traced for a little distance down a short (usually ciliated) œsophagus. There they commonly become aggregated together, so as to form a little pellet of nearly globular form; and this, when it has attained the size of the hollow within which it is moulded, is projected into the

'general cavity of the body,' where it lies in a vacuole of the sarcode, its place in the œsophagus being occupied by other particles subsequently ingested. This 'moulding,' however, is by no means universal; the aggregations of coloured particles in the bodies of these animals being often destitute of any regularity of form. One after another of such particles being thus introduced into the interior of the body, each aggregation seems to push-on its predecessors; and a kind of circulation is thus occasioned in the contents of the cavity. The pellets that first entered make their way out after a time (after yielding up their nutritive materials), generally by a distinct anal orifice, sometimes, however, by any part of the surface indifferently, and sometimes by the mouth. A circumstance which seems clearly to indicate that they cannot be enclosed (as Prof. Ehrenberg maintains) in distinct stomachal cavities, is that, when the pellets are thus moving round the body of the Animalcule, two of them sometimes appear to become fused together, so that they obviously cannot have been separated by any membranous investment. When the Animalcule has not taken food for some time, 'vacuoles' or clear spaces, extremely variable both in size and number, filled only with a very transparent fluid, are often seen in its sarcode; their fluid sometimes shows a tinge of colour, and this seems to be due to the solution of some of the vegetable chlorophyll upon which they may have fed last.

270. Contractile vesicles (Figs. 194, 195, *a, a*), usually about the size of the 'vacuoles,' are found, either singly or to the number of from two to sixteen, in the bodies of most Animalcules; and may be seen to execute rhythmical movements of contraction and dilatation at tolerably-regular intervals, being so completely obliterated when emptied of their contents, as to be quite indistinguishable, and coming into view again as they are refilled. These vesicles do not change their position in the individual, and they are pretty constant, both as to size and place, in different individuals of the same species; hence they are obviously quite different in character from the 'vacuoles.' What is their purpose in the economy of these creatures can be only vaguely guessed-at; it may be surmised to be the diffusion through the body of the liquid product of the digestive operation,—a surmise which seems in some degree justified by their unusual complexity in *Paramecium*. For each of its two globular vesicles (Fig. 195, *a, a*) is surrounded by several elongated cavities, arranged in a radiating manner, so as to give to the whole somewhat of a star-like

aspect; and the liquid contents are seen to be propelled from the former into the latter, and *vice versâ*.

271. Of the Reproduction of the Infusoria, our knowledge is at present very limited; the attention of observers having, until a comparatively recent period, been fixed almost exclusively upon the act of duplicative subdivision, which, though by far the most frequent method of propagation, is not a true generative operation. It is effected in the same general mode as the subdivision of Protophyta; and has been observed in many instances to commence in the 'nucleus,' which may usually be distinguished in the cell-bodies of the Infusoria. The division takes place in some species longitudinally, that is, in the direction of the greatest length of the body (Fig. 196, D, E, F), in other species, transversely (Fig. 199, A, D), whilst in some, as in *Chilodon cucullulus* (Fig. 197), it seems to occur in either

FIG. 197.

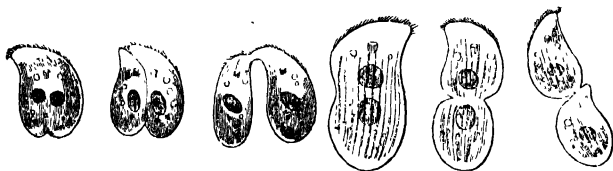

Fissiparous multiplication of *Chilodon cucullulus* — A, B, C, successive stages of longitudinal fission; D, E, F, successive stages of transverse fission.

direction indifferently, though there may not improbably be an alternation, as there usually is in the direction of the subdivision of the component cells of masses that are increasing both in length and in breadth (§ 195). This operation is performed with such rapidity, under favourable circumstances, that, according to the calculation of Prof. Ehrenberg, no fewer than 268 millions might be produced in a month by the repeated subdivisions of a single *Paramecium*. When this fission occurs in *Vorticella* (Fig. 196), one of the divisions is usually smaller than the other, sometimes so much so as to look like a bud; and this usually detaches itself when mature from the main body, and swims freely about until it develops a new footstalk for itself. But sometimes the two parts are

equal in size, and the fission extends down the stalk, which thus becomes double for a greater or less part of its length; and thus a whole bunch of *Vorticellæ* may spring (by a repetition of the same process) from one base. In some members of the same family, indeed, an arborescent structure is produced by the like processes of division and gemmation.

272. The recent observations of Stein and other Microscopists have drawn attention to another very curious mode of propagation, the phenomena of which were completely misapprehended by Prof. Ehrenberg. Many Infusoria at certain times undergo an *encysting* process; that is, their body secretes from its surface a sort of gelatinous case, which hardens so as completely to enclose it, the Animalcule, however, still remaining free in the interior of its coffin-like investment. Previously to the formation of this cyst, the Animalcule loses its activity, its form becomes more rounded, and its cilia or other filamentous prolongations are lost or retracted, as is well seen in *Vorticella* (Fig. 198, A); and it was not, perhaps, very unnatural, that the encysting process should have been considered by Prof. Ehrenberg as the expiring effort of life. If the cysts and their contents, however, be attentively watched, it will be seen that the process is preliminary to a production of new individuals; and this may take-place in different modes. For sometimes the substance of the body appears to break-up (c, d) into numerous 'gemmules,' which are analogous to the 'zoospores' of Protophytes, and which, like them, are set-free by the bursting of the parent-cell (E), swimming forth to develop themselves into new individuals of the same kind, though at first perhaps bearing no resemblance to the type of their predecessor. In other instances, however, only a single offspring is developed from the 'nucleus' of the original cell-body, which offspring may have an entirely dissimilar form; and this latter change occurs in *Vorticella*, in conjunction with other peculiarities of a very remarkable kind. For the encysted *Vorticella* becomes changed into the form of an *Acinetu* (closely resembling that of *Actinophrys*), as shown in Fig. 198, F; and this may acquire a new stalk, so as to correspond with a *Podophrya* (G). At the same time, its band-like nucleus becomes entirely metamorphosed into a free body of ovate form, which carries at its narrower end a circle of long vibrating cilia, while its more obtuse end is perforated by a mouth which communicates with a distinct oral cavity. In the interior of this offspring (H), we already observe a long oval nucleus (b) and a round

contractile vesicle (*c*), and its whole aspect is that of a young Vorticella-bud just ready to quit its stock. This body escapes

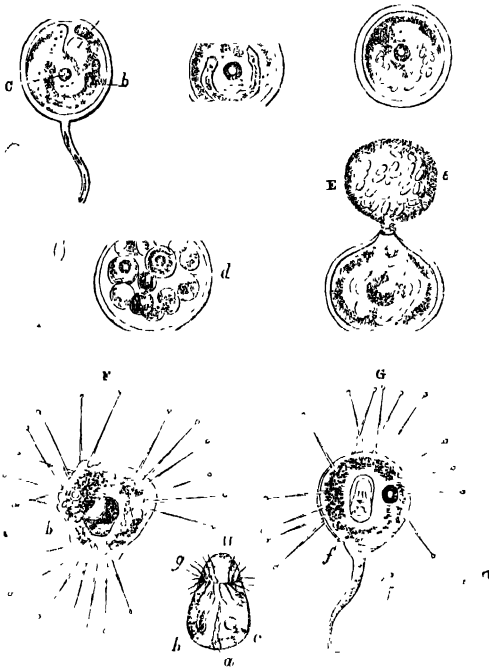

Development and Metamorphoses of *Vorticella microstoma* — *a*, full-grown individual in its encysted state, *a*, retracted oval circlet of cilia; *b*, nucleus; *c*, contractile vesicle; *n*, a cyst separated from its stalk; —*c*, the same more advanced, the nucleus broken-up into spore-like globules; —*d*, the same more developed, the original body of the Vorticella, *d*, having become sacculated, and containing many clear spaces; —*e*, one of the sacculations having burst through the enveloping cyst, a gelatinous mass, *e*, containing the spores, is discharged; —*f*, transformation of encysted Vorticella (*n*) into form of *Acineta*; *b*, nucleus; —*g*, stalked *Acineta*-form of Vorticella, enclosing a young one, the result of the transformation of the nucleus, —*h*, young free Vorticella; *a*, *b*, *c*, as in Fig. 1; *g*, posterior circlet of cilia.

from the interior of the Acineta by a gap formed in some part of its wall, which, however, soon closes again, and the Acineta goes on stretching-out and retracting its radiating filaments, and after a time produces in its interior a new nucleus for a second Vorticella-bud.*

273. Another interesting series of phenomena, of the same order, is presented in the development of the Animalcule

FIG. 199.

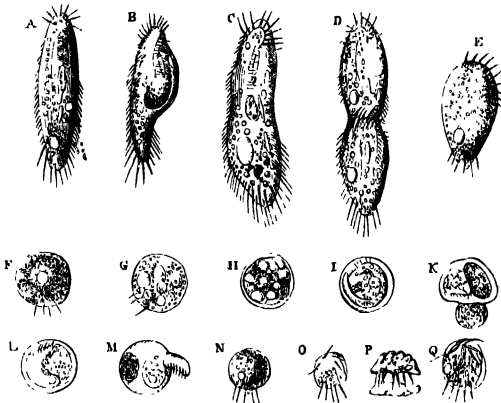

Metamorphoses of *Trichoda lynceus*:—A, larva (*Oxytricha*); B, a similar larva, after swallowing the animalcule represented at M; C, a very large individual on the point of undergoing fission, D, another in which the process has advanced further; E, one of the products of such fission; F, the same body become spherical and motionless; G, aspect of this sphere fifteen days afterwards; H, later condition of the same, showing the formation of the cyst; I, incipient separation between living substance and exuvial matter; K, partial discharge of the latter, with flattening of the sphere; L, more distinct formation of the confined animal, M, its escape from the cyst; N, its appearance some days afterwards; O, more advanced stage of the same; P, Q, perfect individuals, one as seen sideways, moving on its bristles, the other as seen from below; these are magnified twice as much as the preceding figures.

designated by Muller as *Trichoda lynceus*, which has been carefully studied by M. Jules Haime.† The form which

* See Prof. Stein's Memoir in "Siebold and Kolliker's Zeitschrift," Bd. iii., and the translation of it in "Ann. of Nat. Hist.," 2nd Ser., vol. ix., p. 471.

† "Annales des Sci. Nat.," Sér. 3, tom. xix., p. 109.

seems most properly to be considered as the larval one, is that shown in Fig. 199, A-E, which has been described by Prof. Ehrenberg under the name of *Oxytricha*. This possesses a long, narrow, flattened body, furnished with cilia along the greater part of both margins, and having also at its two extremities a set of larger and stronger hair-like filaments; and its mouth, which is an oblique slit on the right-hand side of its fore-part, has a fringe of minute cilia on each lip. Through this mouth, large particles are not unfrequently swallowed, which are seen lying in the midst of the gelatinous contents of the general cavity of the body, without any surrounding 'vacuole;' and sometimes even an animalcule of the same species, but in a different stage of its life, is seen in the interior of one of these voracious little devourers (B). In this phase of its existence, the *Trichoda* undergoes multiplication by transverse fission, after the ordinary mode (C, D); and it is usually one of the short-bodied 'doubles' thus produced (E), that passes into the next phase. This consists in the assumption of the globular form, and the almost entire loss of the locomotive appendages (F); in the escape of successive portions of the granular sarcode, so that 'vacuoles' make their appearance (G); and in the formation of a gelatinous envelope or cyst, which, at first soft, afterwards acquires increased firmness (H). After remaining for some time in this condition, the contents of the cyst become clearly separated from their envelope; and a space appears on one side, in which ciliary movement can be distinguished (I). This space gradually extends all round, and a further discharge of granular matter takes place from the cyst, by which its form becomes altered (K); and the distinction between the newly-formed body to which the cilia belong, and the effete residue of the old, becomes more and more apparent (L). The former increases in size, whilst the latter diminishes; and at last the former makes its escape through an aperture in the wall of the cyst, a part of the latter still remaining within its cavity (M). The body thus discharged (N) does not differ much in appearance from that of the *Oxytricha* before its encystment (F), though only of about two-thirds its diameter; but it soon develops itself (O, P, Q) into an Animalcule very different from that in which it originated. First it becomes still smaller, by the discharge of a portion of its substance; numerous very stiff bristle-like organs are developed, on which the animalcule creeps, as by legs, over solid surfaces; the external integument becomes more consolidated on its upper surface, so as

to become a kind of carapace; and a mouth is formed by the opening of a slit on one side, in front of which is a single hair-like filament, which is made to turn round and round with great rapidity, so as to describe a sort of inverted cone, whereby a current is brought towards the mouth. This latter form has been described by Prof. Ehrenberg under the name of *Aspidisca*. It is very much smaller than the larva; the difference being, in fact, twice as great as that which exists between Δ and p, q (Fig. 199), since the two last figures are drawn under a magnifying power twice as great as that employed for the preceding. How the *Aspidisca*-form in its turn gives origin to the *Oxytricha*-form, has not yet been made-out. A sexual process, it may be almost certainly concluded, intervenes somewhere; but other transformations may not improbably take-place, before the latter of these types is reproduced.

274. A like succession of phenomena has been observed among several other forms of Infusoria; so that, considering the strong general resemblance in kind and degree of organization which prevails throughout the group, it does not seem unlikely that the 'encysting process' occurs at some stage of the life of nearly all these Animalcules, just as the 'still' condition alternates with the 'motile' in the most active Proto-phytes (§§ 152-6). And it is not improbably in the 'encysted' condition that their dispersion takes place; since they have been found to endure desiccation in this state, although, in their ordinary condition of activity, they cannot be dried-up without loss of life. When this circumstance is taken into account, in conjunction with the extraordinary rapidity of multiplication of these Animalcules, and with the fact that a succession of different forms may be presented by one and the same being, the difficulty of accounting for the universality of their diffusion, which has led some Naturalists to believe in their 'spontaneous generation,' and others to regard them as isolated particles of higher organisms set-free in their decomposition so as to constitute an 'equivocal generation,' is as readily got-over as we have seen it to be in the case of the Fungi (§ 211). Although it may be stated as a general fact, that wherever decaying organic matter exists in a liquid state, and is exposed to air and warmth, it speedily becomes peopled with these minute inhabitants, yet it has been experimentally proved by Prof. Schultz, that perfectly *free* access of air to such infusions, is essential to the appearance of Animalcules in them. For having kept infusions of decaying animal and

vegetable matter, in air which had been filtered (so to speak) of any floating germs it might contain, by passing through either a red-hot tube or strong sulphuric acid, he found that no Animalcules made their appearance under these circumstances, even after the lapse of several weeks; although they were seen in abundance after the free exposure of the same infusions to the atmosphere for a few hours only. Hence it may be fairly inferred, that, as seems to be the case with the Fungi, the dried cysts or the germs of Infusoria are everywhere floating about in the air, ready to develop themselves wherever the appropriate conditions are presented; and all our knowledge of their history, as well as the strong analogy of the Fungi, seems further to justify the belief, that the same germs may develop themselves into several different forms, according to the nature of the liquid in which they chance to be deposited. — This is a subject peculiarly worthy of the attention of Microscopic observers; who can scarcely be better employed than in tracing-out the succession of phases which any particular type may present, and thus in making a most important extension of our knowledge of its life-history, whilst at the same time effecting a most desirable reduction in the number of reputed species. Such a study, if perseveringly as well as carefully pursued, would be almost certain to lead to the discovery of the true generative process in these creatures, of which we cannot at present be said to know anything with certainty. For although an apparent ‘conjugation’ has been observed between the bodies of distinct individuals, both in the ordinary active states of Infusoria, and in their *Acineta*-condition, yet this does not seem truly to represent the sexual union of higher animals; for the blending of the two individuals is not so complete as to amount to the ‘fusion’ we have seen to occur in previous instances, the boundaries of each remaining distinctly traceable; and not only two, but three, four, or even more, have been found in continuous union.

275. It is obvious that no Classification of Infusoria can be of any permanent value, until it shall have been ascertained, by the study of their entire life-history, what are to be accounted really distinct forms; and the differences between them, consisting chiefly in the shape of their bodies, the disposition of their cilia, the possession of other locomotive appendages, the position of the mouth, the presence of a distinct anal orifice, and the like, are matters of such trivial importance as compared with those leading features of their structure and physiology on which we have been dwelling,

that it does not seem desirable to attempt in this place to give any account of them. The most remarkable departure from the ordinary type is presented by the *Vorticellinæ*, the habit of which is to attach themselves to the stems of aquatic plants or some other supports, either by the apex of their own conical body,—as is the case with *Stentor*, one of the largest of all Infusoria (being visible to the naked eye), which is very common in ponds and ditches, attaching itself to duck-weed, decaying reeds, or other floating bodies, round which it forms a sort of slimy fringe, but which is often found swimming freely, its trumpet-shaped body drawn together into the form of an egg,—or by a footstalk several times its own length, as is the case with *Vorticella* (Fig. 196), which also occasionally quits its attachment (the stalk apparently dying and being thrown-off), and swims rapidly through the water, being propelled by the fringe of cilia, which, when the body was fixed by its stalk, served to produce a vortex in the surrounding fluid, that brought it both food and air.—Another curious departure from the ordinary type is presented by the family *Ophrydinæ*; the animalcules of which, closely resembling some *Vorticellinæ* in their individual structure, are usually found imbedded in a gelatinous mass, of a greenish colour, which is sometimes adherent, sometimes free, and may attain the diameter of four or five inches, presenting such a strong general resemblance to a mass of *Nostoc* (§ 196) or even of Frogs' spawn, as to have been mistaken for such. The mode in which these masses are produced closely resembles that in which the masses of *Mastogloia* (§ 189) or of *Palmella* (§ 194) are formed; since they simply result from the fact, that the multitude of individuals produced by a repetition of the process of self-division, remain connected with each other for a time by a gelatinous exudation from the surface of their cell-bodies, instead of at once becoming completely isolated. From a comparison of the dimensions of the individual *Ophrydia*, each of which is about 1-120th of an inch in length, with those of the composite masses, some estimate may be formed of the number included in the latter; for a cubic inch would contain nearly *eight millions* of them, if they were closely packed; and many times that number must exist in the larger masses, even making allowance for the fact that the bodies of the animalcules are separated from each other by their gelatinous cushion, and that the masses have their central portions occupied only by water. Hence we have, in such clusters, a distinct proof of the extraordinary extent to which

multiplication by duplicative subdivision may proceed, without the interposition of any other operation. These animalcules, however, free themselves at times from their gelatinous bed; and have been observed to undergo an 'encysting-process,' corresponding with that of the *Vorticellinæ* (§ 272).—It is much to be desired that Microscopic observers should devote themselves systematically to the continuous study of even the commonest and best-known forms of these Animalcules; since there is *not a single one*, whose entire life-history, from one Generative act to another, is known to us. And since it cannot be even guessed-at, without such knowledge, what, among the many dissimilar forms that have been described by Prof. Ehrenberg and others, are to be accounted as truly-distinct species, and what are mere phases in the existence of others that are perhaps very dissimilar to them in aspect, it is obvious that no credit is really to be gained by the discovery of any number of apparently-new species, which shall be at all comparable with that to be acquired by the complete and satisfactory elucidation of the life-history of any one.*

276. As it is among Animalcules that the action of the organs termed *cilia* has the most important connection with the vital functions, it seems desirable to introduce here a more particular notice of them. They are always found in connection with *cells*, of whose substance, as we have seen among the *Protophyta* (§§ 154, 158), they may be considered as extensions. The form of the filaments is usually a little flattened, and tapering gradually from the base to the point. Their size is extremely variable; the largest that have been observed being about 1-500th of an inch in length, and the smallest about 1-13,000th. When in motion, each filament appears to bend from its root to its point, returning again to its original

* The recent memoirs of Prof. Stein in "Wiegmann's Archiv," and in "Siebold and Kolliker's Zeitschrift," which have been separately published in a collective form, "Die Infusionsthierchen," Leipsic, 1851, contain most valuable contributions to the desolated knowledge, as do also the memoirs of Dr. Cohn in "Siebold and Kolliker's Zeitschrift." The great work of Prof. Ehrenberg, "Die Infusionsthierchen," will always remain a standard of reference, as the basis of all our higher knowledge of these organisms; but its authority has been completely destroyed by the proof which has been gradually accumulating, of the erroneous conceptions on which he based his descriptions; *first*, as to what *are* Infusory Animalcules, a very large proportion of those considered by him as such being undoubtedly Plants;—*second*, as to the organization of the true Infusoria, the complex digestive apparatus, genital organs, nervous system, and organs of sense, which he believed that he had discovered in them, having no existence but in his imagination;—and, *third*, as to the relations of his supposed species one to another, many of these being only different states of the same.

state, like the stalks of corn when depressed by the wind; and when a number are affected in succession with this motion, the appearance of progressive waves following one another is produced, as when a corn-field is agitated by successive gusts. When the ciliary action is in full activity, however, little can be distinguished save the whirl of particles in the surrounding fluid; but the *back-stroke* may often be perceived, when the *forward-stroke* is made too quickly to be seen; and the real direction of the movement is then opposite to the apparent. In this back-stroke, when made slowly enough, a sort of 'feathering' action may be observed; the thin edge being made to cleave the liquid, which has been struck by the broad surface in the opposite direction. It is only when the rate of movement has considerably slackened, that the shape and size of the cilia, and the manner in which their stroke is made, can be clearly seen. It has been maintained by some, that the action of the cilia is muscular; but they are often too small to contain even the minutest fibrillæ of true muscular tissue, and no such elements can be discerned around their base; their presence in Plants, moreover, seems distinctly to negative such an idea. Hence we must consider them as organs *sui generis*, wherein the contractility of the cell to which they belong, is (as it were) concentrated. We have seen that in the *Rhizopods*, the entire mass of whose sarcode is highly contractile, no cilia are present; whilst in the Infusoria, whose bodies have comparatively little contractility, the movements are delegated to the cilia.—Cilia are not confined, however, to Animalcules and Zoophytes, but exist on some of the free internal surfaces, especially the walls of the respiratory passages, of all the higher animals, not excepting Man himself. Our own experience assures us that their action takes place, not only without any exercise of will on our own parts, but even without affecting our *consciousness*; and it has been found to continue for many hours, or even days, after the death of the body at large. How far it is subject to any conscious control on the part of these Animalcules, in which the cilia serve as instruments for locomotion as well as for bringing to them food or oxygen, it is impossible for any one to say with confidence. In this important respect, however, the ciliary movement of Animalcules differs from that which is observable in the higher Animals,—that whilst in the latter it is *constant*, giving the idea of purely mechanical agency, in the latter it is so interrupted and renewed, as almost necessarily to suggest to the observer the notion of choice and direction.

277. *Rotifera, or Wheel Animalcules.*—We now come to that higher group of Animalcules, which, in point of complexity of organization, is as far removed from the preceding, as Mosses are from the simplest Protophytes; the only point of real resemblance between the two groups, in fact, being the minuteness of size which is common to both, and which was long the obstacle to the recognition of the comparatively-elevated character of the Rotifera, as it still is to the precise determination of certain points of their structure. Some of the Wheel-Animalcules are inhabitants of salt-water only, but by far the larger proportion are found in collections of fresh-water, and rather in such as are free from actively-decomposing matter, than in those which contain organic substances in a putrescent state. Hence when they present themselves in vegetable infusions, it is usually after that offensive condition, which is favourable to the development of many of the Infusoria, has passed-away; and they are consequently to be looked-for, after the disappearance of many successions (it may be) of Animalcules of inferior organization. Rotifera are more abundantly developed in liquids which have been long and freely exposed to the open air, than in such as have been kept under shelter; certain kinds, for example, are to be met-with in the little pools left after rain in the hollows of the lead with which the tops of houses are partly covered; and they are occasionally found in enormous numbers in cisterns which are not beneath roofs or otherwise covered-over.* They are not, however, absolutely confined to collections of liquid; for there are a few species which can maintain their existence in damp earth; and the common *Rotifer* is occasionally found in the interior of the leaf-cells of *Sphagnum* (§ 216).—The wheel-like organs from which the class derives its designation, are most characteristically seen in the common form just mentioned (Fig. 201), where they consist of two disk-like lobes or projections of the body, whose margins are fringed with long cilia; and it is the uninterrupted succession of strokes given by these cilia, each row of which nearly returns (as it were) into itself, that gives-rise by an optical illusion to the notion of ‘wheels.’ This arrangement, however, is by no means universal; in fact, it obtains in only a small proportion of the group; and by far the more general plan is that seen in Fig. 200, in which the cilia form one continuous line across the body, being disposed upon the

* See a remarkable instance of this in p. 270, *note*.

sinuous edges of certain lobes or projections which are borne upon its anterior portion. Some of the chief departures

from this plan will be noticed hereafter (§ 281).—

The great transparency of the Rotifera permits their general structure to be easily recognized. They have usually an elongated form, similar on the two sides; but this rarely exhibits any traces of segmental division. The body is covered with a double envelope; both layers of which are extremely thin and flexible in some species; whilst in others, the outer one seems to possess a horny consistence. In the former case, the whole integument is drawn-together in a wrinkled manner when the body is shortened; in some of the latter the sheath has the form of a polype-cell, and the body lies loosely in it, the inner layer of the integument being separated from the outer by a considerable space (Fig. 202); whilst in others, the envelope or *lorica* is tightly fitted to the body,

and strongly resembles the horny casing of an insect or the shell of a crab, except that it is not jointed, and does not extend over the head and tail, which can be projected from the openings at its extremities, or completely drawn within it for protection (Fig. 203). In those Rotifera in which the flexibility of the body is not interfered-with by the consolidation of the external integument, we usually find it capable of great variation in shape, the elongated form being occasionally exchanged for an almost globular one, as is seen especially when the animals are suffering from deficiency of water; whilst by alternative movements of contraction and extension, they can make their way over solid surfaces, after the manner of a worm or a leech, with

FIG. 200.

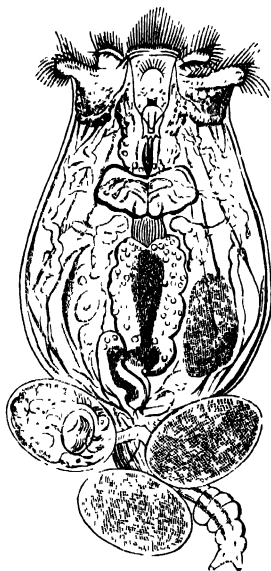
*Brachionus pala.*

considerable activity,—some even of the loricated species being rendered capable of this kind of progression, by the contractility of the head and tail. All these, too, can swim readily through the water, by the action of their cilia; and there are some species which are limited to the latter mode of progression. The greater number have an organ of attachment at the posterior extremity of the body, which is usually prolonged into a tail, by which they can affix themselves to any solid object; and this is their ordinary position, when keeping their wheels in action for a supply of food or of water. They have no difficulty, however, in letting-go their hold and moving through the water in search of a new attachment, and may therefore be considered as perfectly free; the polypoid species, however, remain attached by the posterior extremity to the spot on which they have at first fixed themselves, and their cilia are consequently employed for no other purpose than that of creating currents in the surrounding water.

278. In considering the internal structure of Rotifera, we shall take as its type the arrangement which it presents in the *Rotifer vulgaris* (Fig. 101); and specify the principal variations exhibited by others. The body of this animal, when fully extended, possesses greater length in proportion to its diameter than that of most others of the class; and the tail is composed of three joints or segments, which are capable of being drawn-up, one within another, like the sliding-tubes of the telescope, each having a pair of prongs or points at its extremity. Within the external integument of the body, are seen a set of longitudinal muscular bands (*b*), which serve to draw the two extremities towards each other; and these are crossed by a set of transverse annular bands, which also are probably muscular, and serve to diminish the diameter of the body, and thus to increase its length. Between the wheels is a prominence, bearing two red spots (*b*), supposed to be rudimentary eyes, and having the mouth (*a*) at its extremity; this prominence may be considered, therefore, as a true head, notwithstanding that it is not clearly distinguishable from the body. This head also bears upon its under surface a projecting tubular organ (*d*), which was thought by Professor Ehrenberg to be a siphon for the admission of water to the cavity of the body for the purpose of respiration; this, however, is certainly not the case, the tube being imperforate at its extremity; and there seems much more probability in the idea of Dujardin, that it represents the *antennæ* or *palpi* of higher Articulata, the single organ being replaced in many

Rotifera by a pair, of which each is furnished at its extremity with a brush-like tuft of hairs that can be retracted into the tube. The œsophagus, which is narrow in the *Rotifer*, but which is dilated into a crop in *Stephanoceros* (Fig. 202) and in some other genera, leads to the masticating apparatus, which in these animals is placed far behind the mouth, and in close proximity to the stomach. It consists of a pair of stirrup-shaped jaws (Fig. 201, *e*),

each having from one to five teeth (in *Rotifer*, two), which appear to contain mineral matter and to be of harder texture than the rest of the fabric; these jaws are put in action by powerful muscles, and are so moved that all the food which passes into the stomach is subject to be divided and torn by their teeth. In many Rotifera, the conformation of this masticating apparatus is extremely complicated. The form of the alimentary canal varies; this being sometimes a simple tube, passing without enlargement or constriction from the masticating apparatus to the anal orifice at the posterior part of the body; whilst in other instances there is a marked distinction between the stomach and intestinal tube, the former being a large globular dilatation immediately below the jaws, whilst the latter is cylindrical and comparatively small. The alimentary canal of *Rotifer* most resembles the first

FIG. 201.

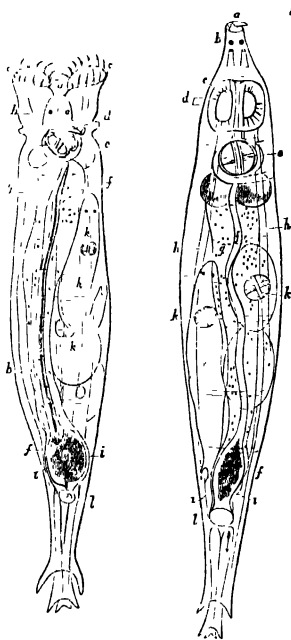

Rotifer vulgare, as seen at *a*, with the wheels drawn-in and at *b* with the wheels expanded—*a*, mouth; *b*, eye-spots; *c*, wheels; *d*, calcifer (antenna?); *e*, jaws and teeth; *f*, alimentary canal; *g*, glandular (?) mass inclosing *b*; longitudinal muscles; *h*, *i*, tubes of water-vascular system; *j*, young animal; *l*, cloaca.

of these types, but presents a dilatation (*l*) close to the anal orifice, which may be considered as a cloaca; that of *Brachionus* (Fig. 200) is rather formed upon the second. Connected with the alimentary canal are various glandular appendages, more or less developed; sometimes clustering round its walls as a mass of separate follicles, which seems to be the condition of the glandular investment (*g*) of the alimentary canal in *Rotifer*; in other cases having the form of cœcal tubuli. Some of these open into the stomach close to the termination of the œsophagus, and have been supposed to be salivary or pancreatic in their character; whilst others, which discharge their secretion into the intestinal tube, have been regarded, and probably with correctness, as the rudiment of a liver. In a curious animalcule of this class, minutely described by Mr. Dalrymple,* although the mouth, masticating apparatus, and stomach are constructed upon the regular type of the genus *Notommata*, to which it seems nearly allied, yet there is neither intestine nor anal orifice, and the indigestible matters are rejected through the mouth. This, so far as is yet known, is a solitary example of the existence of this character of degradation in the class Rotifera. There does not appear to be any special circulating apparatus in these animals; but the fluid which is contained in the general cavity of the body, between the exterior of the alimentary canal and the inner tegumentary membrane, is probably to be regarded as nutritive in its character; and its aeration is provided-for by a peculiar apparatus, which seems to be a rudimentary form of the 'water-vascular system,' that attains a high development in the class of Worms. On either side of the body there is usually to be observed a long flexuous tube (Fig. 200), which extends from a contractile vesicle common to both and opening into the cloaca (Fig. 201, *i, i*), towards the anterior region of the body, where it frequently subdivides into branches, one of which may arch-over towards its opposite side, and inosculate with a corresponding branch from its tube. Attached to each of these tubes are a number of peculiar organs (usually from two to eight on each side), in which a trembling movement is seen, very like that of a flickering flame; these appear to be pear-shaped sacs, attached by hollow stalks to the main tube, having a long cilium in the interior of each, that is attached by one extremity to the interior of the sac, and vibrates with a quick undulatory

* "Philos. Transact.," 1849, p. 339.

motion in its cavity; and there can be little doubt that their purpose is to keep-up a constant movement in the contents of the aquiferous tubes, whereby fresh water may be continually introduced from without, for the aeration of the fluids of the body.*—There is much uncertainty with regard to the structures which Prof. Ehrenberg has described as ganglia and nerves; and it seems doubtful if there is more than a single nervous centre in the neighbourhood of the single, double, or multiple red spots, which are seen upon the head of the Rotifera, and which, corresponding precisely in situation with those that in the higher Articulata are unquestionably eyes, are probably to be regarded as rudiments of visual organs.

279. The Reproduction of the Rotifera has not yet been completely elucidated. There is no instance, in this group, in which multiplication by gemmation or spontaneous fission is certainly known to take place; but the occurrence of clusters formed by the aggregation of a number of individuals of *Conochilus*, adherent by their tails, and enclosed within a common *lorica*, would seem to indicate that these clusters, like the aggregations of *Polygastrica*, *Bryozoa*, and *Tunicata*, must have been formed by continuous growth from a single individual. The ordinary method of multiplication, however, is commonly supposed to be by a proper generative act; as distinct sexes have been discovered in several individuals, and the act of sexual union has been witnessed. The condition of the male of the remarkable genus described by Mr. Dalrymple (loc. cit.) is a most extraordinary one; for it possesses no mandibles, pharynx, œsophagus, stomach, nor hepatic glands; having, in fact, no other organs fully developed, than those of generation. It would appear, therefore, quite unfit to obtain aliment for itself; and its existence is probably a very brief one, being continued only so long as the store of nutriment supplied by the egg remains unexhausted. In *Rotifer*, however, as in by far the larger proportion of the class, no males have been discovered; and it remains doubtful whether the two sexes are united in the same individual, or whether the males are produced only at certain times. The female organ consists but of a single ovarian sac, which fre-

* See Mr. Huxley's account of these organs, in his description of *Lucinularia socialis*, "Transact. of Microsc. Soc.," Ser. 2, vol. 1.—Other observers have supposed that the pyriform sacs communicate with the general cavity of the body; but the Author has much confidence in the correctness of Mr. Huxley's statements on this point.

quently occupies a large part of the cavity of the body, and which opens at its lower end by a narrow orifice into the cloaca. Although the number of eggs in these animals is so small, yet the rapidity with which the whole process of their development and maturation is accomplished, renders the multiplication of the race very rapid. The egg of the *Hydatina* is extruded from the cloaca within a few hours after the first rudiment of it is visible; and within twelve hours more the shell bursts, and the young animal comes forth. In the *Rotifer* and several other genera, the development of the embryo takes place whilst the egg is yet retained within the body of the parent (Fig. 201, *k*), and the young are extruded alive; whilst in some other instances, the eggs, after their extrusion, remain attached to the posterior extremity of the body (Fig. 200), until the young are set-free. In general it would seem that, whether the rupture of the egg-membrane takes place before or after the egg has left the body, the germinal mass within it is developed at once into the form of the young animal, which resembles that of its parent; no preliminary metamorphosis being gone through, nor any parts developed which are not to be permanent. The transparency of the egg-membrane, and also of the tissues, of the parent Rotifer, allows the process of development to be watched, even when the egg is retained within the body; and it is curious to observe, at a very early period, not merely the red eye-spot of the embryo, but also a distinct ciliary movement. The multiplication of *Hydatina* (in which genus three or four eggs are deposited at once, and their development completed out of the body) takes place so rapidly, that, according to the estimate of Prof. Ehrenberg, nearly *seventeen millions* may be produced within twenty-four days from a single individual. Even in those species which usually hatch their eggs within their bodies, a different set of ova is occasionally developed, which are furnished with a thick glutinous investment: these, which are extruded entire, and are laid one upon another, so as at last to form masses of considerable size in proportion to the bulk of the animals, seem not to be destined to come so early to maturity, but very probably remain dormant during the whole winter season, so as to produce a new brood in the spring. These 'winter-eggs' are inferred by Mr. Huxley, from the history of their development, to be really *gemmae* produced by a non-sexual operation; while the bodies commonly called ova, he considers to be true generative products. Dr. Cohn has recently informed the Author, however, that he has ascer-

tained by direct experiment upon those species in which the sexes are distinct, that the bodies commonly termed ova (Figs. 200, 201), are really *internal gemmæ*, since they are reproduced, through many successions, without any sexual process, just like the external gemmæ of *Hydra* (§ 301), or the internal gemmæ of *Entomostraca* and *Aphides* (Chap. XVI). And this view appears to himself to be more accordant with general physiological analogy, than that of Mr. Huxley; since, in the other instances referred-to, as in the Rotifera, the multiplication by gemmation goes on rapidly whilst food and warmth are abundantly supplied; but gives place to the true generative process, when the nutritive activity is lowered by their withdrawal.

280. Certain Rotifera, among them the common Wheel-Animalcule, are remarkable for their tenacity of life, even when reduced to the state of most complete dryness; for they can be kept in this condition for any length of time, and will yet revive very speedily upon being moistened. Experiments have been carried still farther with the allied tribe of *Turridigrades*; individuals of which have been kept in a vacuum for thirty days, with sulphuric acid and chloride of calcium (thus suffering the most complete desiccation that the Chemist can effect), and yet have not lost their capability of revivification. This fact, taken in connexion with the extraordinary rate of increase mentioned in the preceding paragraph, removes all difficulty in accounting for the extent of the diffusion of these animals, and for their occurrence in incalculable numbers in situations where, a few days previously, none were known to exist. For their entire bodies may be wafted in a dry state by the atmosphere, from place to place; and their return to a state of active life, after a desiccation of unlimited duration, may take place whenever they meet with the requisite conditions,—moisture, warmth, and food. It is probable that the ova are capable of sustaining treatment even more severe than the fully-developed animals can bear; and that the race is frequently continued by them, when the latter have perished.

281. The principles on which the various forms that belong to this class should be systematically arranged, have not yet been satisfactorily determined. By Prof. Ehrenberg, the disposition of the ciliated lobes or wheel-organs, and the enclosure or non-enclosure of the body in a *lorica* or case, were taken as the basis of his classification; but as his ideas on both these points are inconsistent with the actual facts of organisation, the arrangement founded upon them cannot be

received. Another division of the class has been propounded by M. Dujardin, which is based on the several modes of life of the most characteristic forms. And in a third, more recently put-forth by Prof. Leydig, the general configuration of the body, with the presence, absence, and conformation of the foot (or tail), are made to furnish the characters of the subordinate groups. Either of the two latter is certainly more

FIG. 202.

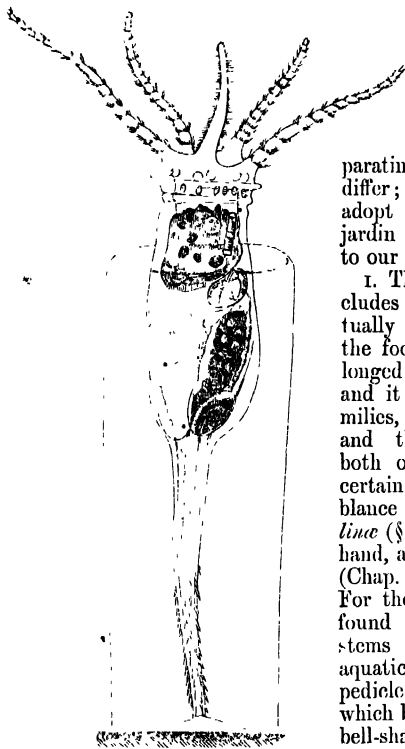
*Stephanoceros Eichornii.*

natural than the first, as bringing-together for the most part the forms which most agree in general organization, and separating

those which differ; and we shall adopt that of M. Dujardin as most suitable to our present purpose.

1. The first group includes those that habitually live attached by the foot, which is prolonged into a pedicle; and it includes two families, the *Floscularians* and the *Melicerians*, both of which bear a certain general resemblance to the *Vorticelline* (§ 268) on the one hand, and to *Zoophytes* (Chap. xi.) on the other. For they are commonly found attached to the stems and leaves of aquatic plants, by a long pedicle or foot-stalk, which bears a somewhat bell-shaped body; and in one of the most beautiful species, the *Stephano-*

ceros Eichornii (Fig. 202), this body has five long tentacles, beset with tufts of short bristly cilia, reminding us of the ciliated tentacles of the Bryozoa (Chap. XIII.), whilst the body seems to be enclosed in a cylindrical cell, resembling that of Hydrozoa and Bryozoa. A comparison of this with other forms, however, shows that these tentacles are only extensions of the ciliated lobes which are common to all the members of these families; and the so-called 'cell' is not formed by a thickening and separation of the outer tegument, but by a gelatinous secretion from it; so that, as the rest of the organisation is essentially conformable to the Rotiferous type, no such passage is really established by this animal towards other groups, as it is commonly supposed to form. In one respect, *Floscularia* is still more aberrant; for the long bristly filaments with which its lobes are beset, are not capable of rhythmical vibration, and cannot, therefore, be properly termed 'cilia.' The body of *Melicerta* is protected by a most curious cylindrical tube, composed of little rounded pellets agglutinated together; this is obviously an artificial construction; and Mr. Gosse has been fortunate enough to have an opportunity of watching the animal whilst engaged in building it up. Beneath a projection on its head which he terms the chin, there is observed a small disk-like organ, in which, when the wheels are at work, a movement is seen very much resembling that of a revolving ventilator. Towards this disk, the greater proportion of the solid particles that may be drawn from the surrounding liquid into the vortex of the wheel-organs, are driven by their ciliary movement, a small part only being taken into the alimentary canal; and there they accumulate, until the aggregation (probably cemented by a glutinous secretion furnished by the organ itself) acquires the size and form of one of the globular pellets of the case; the time ordinarily required being about three minutes. The head of the animal then bends itself down, the pellet-disk is applied to the edge of the tube, the newly-formed pellet is left attached there, and, the head being lifted into its former position, the formation of a new pellet at once commences.

II. The next of M. Dujardin's primary groups (ranged by him, however, as the third), consists of the ordinary *Rotifer* and its allies, which pass their lives in a state of alternation between the conditions of those attached by a pedicle, of those which habitually swim freely through the water, and of those which creep or crawl over hard surfaces. As these

have already been fully described, it is not requisite to dwell longer upon them.

III. The next group consists of those Rotifers which seldom or never attach themselves by the foot, but habitually swim freely through the water; and putting aside the peculiar aberrant form *Albertia*, which has only been found as a parasite in the intestines of worms, it may be divided into two families, the *Brachionians* and the *Furcularians*. The former are for the most part distinguished by the short, broad, and flattened form of the body (Figs. 200, 203); which is, more-

FIG. 203.

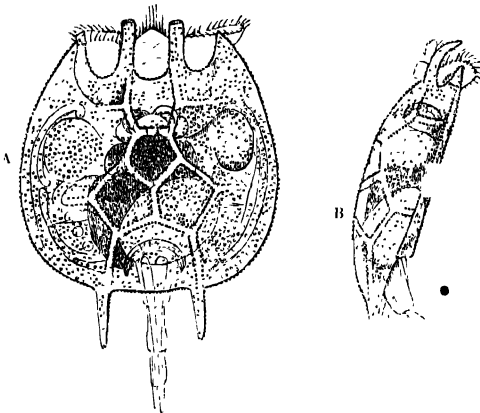

Noteus quadricornis; A, dorsal view, B, side view.

over, enclosed in a sort of cuirass, formed by the consolidation of the external integument. This cuirass is often very beautifully marked on its surface, and may be prolonged into extensions of various forms, which are sometimes of very considerable length. The latter (corresponding almost exactly with the *Hydatineæ* of Prof. Ehrenberg) derive their name from the bifurcation of the foot into a sort of two-bladed forceps; their bodies are ovoidal or cylindrical, and are enclosed in a flexible integument, which is often seen to wrinkle itself into longitudinal and transverse folds, at equidistant lines. To this family belongs the *Hydatina senta*, which is one of the largest of the Rotifera, and which was

employed by Prof. Ehrenberg as the chief subject of his examination of the internal structure of this group; as does also the *Notommata*, the curious condition of whose male has been already referred-to (§ 279).

iv. The fourth of M. Dujardin's primary orders consists of the very curious tribe, first carefully investigated by M. Doyère, to which the name of *Tardigrada* has been given, on account of the slowness of their creeping movement. Their relation to the true Rotifera, however, is not at all clear; and many naturalists regard them as altogether distinct. They are found in the same localities with the Rotifers, and, like them, can be revived after desiccation (§ 280); but they have a vermiform body, divided transversely into five segments, of which one constitutes the head, whilst each of the others bears a pair of little fleshy protuberances, furnished with four curved hooks, and much resembling the pro-legs of a caterpillar. The head is entirely unpossessed of ciliated lobes; and it is only in the presence of a pair of jaws somewhat resembling those of Rotifera, and in the correspondence of their general grade of organisation, that they bear any structural relation to the class we have now been considering. They may be pretty certainly regarded as a connecting link between the Rotifera and the Worms; but they should probably be ranked on the worm-side of the boundary.

282. Notwithstanding that all the best-informed Zoologists are now agreed in ranking the class of Rotifera in the Articulated series, yet there is still a considerable discordance of opinion as to the precise part of that series in which they should stand. For whilst Prof. Leydig, who has recently devoted much attention to the study of the class, regards them as most allied to the *Crustacea*, and terms them 'Ciliocrustaceans,' Mr. Huxley, with (as it seems to the Author) a clearer insight into their real nature, has argued that they are more connected with the *Annelida*, through the resemblance which they bear to the early larval forms of that class (Fig. 274). Considered in this light, the *Tardigrada* might seem to represent a more advanced phase of the same developmental history.*

* In addition to the classical works of Ehrenberg and Dujardin, the following Memoirs should be consulted (besides those already referred-to) by such as wish to acquaint themselves with the best researches upon the Rotifera:—Leydig in "Siebold and Kolliker's Zeitschrift," Band vi., heft 1; Gosse on *Melucerta ringens*, in "Transact. of Microsc. Soc.," Ser. I., vol. iii., p. 58; and "Quart. Journ. of Microsc. Sci.," vol. i., p. 71; Williamson on *Melucerta ringens*, Op. cit., p. 1; and Huxley on *Lacinularia socialis*, in "Transact. of Microsc. Soc.," Ser. II., vol. i., p. 1.

CHAPTER X.

FORAMINIFERA, POLYCYSTINA, AND SPONGES

283. RETURNING now to the lowest or *Rhizopod* type of Animal life (§ 264), we have to direct our attention to three very remarkable series of forms, almost exclusively marine, under which that type manifests itself; all of them being distinguished by a *skeleton* of greater or less density; and this skeleton being generally so consolidated by mineral deposit, as to retain its form and intimate structure, long after the animal to which it belonged has ceased to live, even for those undefined periods in which they have been imbedded as fossils in strata of various geological ages. In the first of these groups, the *Foraminifera*, this skeleton consists of a *calcareous* shell (save in a few exceptional cases, in which the *lorica* remains flexible), that invests the *sarcode-body*, but is usually perforated with numerous minute apertures. In the second group, also, the *Polycystina*, there is an investing shell, perforated with numerous apertures; but this shell is *siliceous*, instead of *calcareous*. In the third group, on the other hand,—that of *Porifera*, or *Sponges*,—the skeleton is usually composed of a network of horny fibres, strengthened either by *calcareous* or *siliceous* spicules, and having the soft animal body, which is composed of an aggregate of *Amœba-like* cells, in its interstices: in this group, moreover, we have a departure from the *Rhizopod* type, in the fact that certain parts of the free surfaces are furnished with *cilia*, whereby currents of water are sustained, that serve both for nutrition and for respiration.

284. *Foraminifera*.—The beings now known under this designation, possess, for the most part, *polythalamous* or ‘many-chambered’ shells (Fig. 336), so strongly resembling those of *Nautilus*, *Spirula*, and other Cephalopod Mollusks, that it is not surprising that the older Naturalists, to whom the structure of these animals was entirely unknown, ranked them under that class. As such they were described by M. D’Orbigny (to whom we owe much of our knowledge of this group),

in all his earlier publications; and they were distinguished from the ordinary Cephalopods that possess a single siphon passing from chamber to chamber, by the designation *Foraminifera*, which originally imported that the communications *between the chambers* are commonly made by several such apertures, though it is now more commonly understood as applying to the sieve-like structure often presented by the external shell.—It was by M. Dujardin, in 1835, that the structure of these animals was first shown to be conformable to the Rhizopod type; and notwithstanding the opposition to his views which has been set-up by Prof. Ehrenberg (who, with inexplicable pertinacity, has continued to rank them among his *Bryozoa*, Chap. XIII.), they have been confirmed by all subsequent observers, and more especially by the recent researches of Prof. Schulze,* who has given admirable descriptions of the animals of several different kinds of Foraminifera, derived from observation of them during their living state.—The conformity of the Foraminifera to the ordinary Rhizopod type, is best seen in those forms, such as *Gromia* (Fig. 204), in which there is no multiplication of chambers; and it is made obvious by an examination of the accompanying figure, that there is no other essential difference between *Gromia* and *Arcella* or *Diffugia* (Fig. 193), than that which lies in the greater length and slenderness of the pseudopodial prolongations of the sarcode-body in the former, as compared with those of the latter. The food is obtained by the extension of these pseudopodia in various directions from the mouth of the shell; and the absence of any membrane investing them is clearly indicated by their fusion or coalescence when two or more happen to come into contact, as well as by the vagueness of the expansions into which they are occasionally seen to spread-out. These instruments entangle and lay-hold-of the minute bodies which serve as food to the animals, consisting of Diatomacæ, Desmidiæ, the smaller forms of Convolvæ, &c.; and they draw these, by their contraction, into the substance of the body, within which they may be seen through the transparent shell. It is not by any means constantly, that their indigestible *residua* are cast forth again, as we have seen them to be from the surface of the body of the Actinophrys (§ 262); for they sometimes accumulate in considerable numbers, so as even to choke-up a large part of the cavity. The sarcode-body is occasionally seen to extend

* "Über den Organismus der Polythalamien (Foraminiferen)." Leipzig, 1854.

itself, as shown in Fig. 204, around the exterior of the shell; and pseudopodia are put-forth from this extension, as well

FIG. 204.

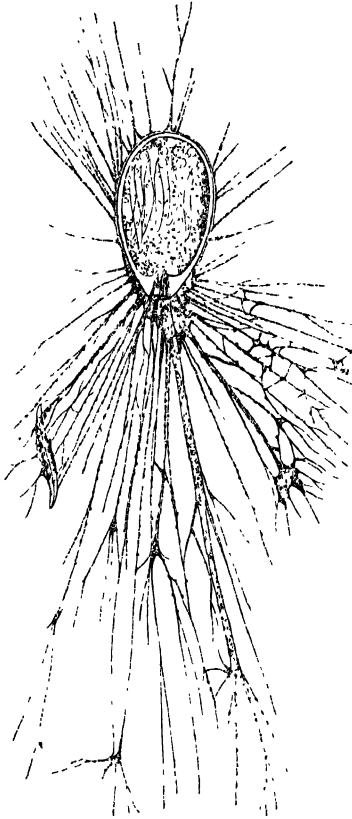

Gromia aciformis, with its pseudopodia extended.

as from the ordinary outlet. Although nothing is certainly known of the mode of propagation of these animals, yet it

is probable, from the analogy of the composite forms, that they multiply themselves by the detachment of gemmæ, composed of portions of sarcode, which in time form an envelope or shell. Nothing has been yet seen, that in the least corresponds to a true Generative process.

285. By far the greater number of Foraminifera are *composite* fabrics, evolved by a process of continuous gemmation, each gemma remaining in connection with the body by which it was put-forth; and according to the plan on which this gemmation takes-place, will be the configuration of the composite body thereby produced. Thus if the bud should be put-forth from the aperture of *Gromia*, in the direction of the axis of its body, and a second shell should be formed around this bud, in continuity with the first, and this process should be successively repeated, a straight rod-like shell will be produced, having many chambers communicating with each other by the openings that originally constituted their mouths, the mouth of the last formed chamber being the only aperture through which the sarcode body, thus composed of a number of segments connected by a peduncle or 'stolon' of the same material, can now project itself or draw-in its food. The successive segments may be all of the same size, or nearly so, in which case the entire rod will approach the cylindrical form, or will resemble a line of beads; but it often happens that each segment is somewhat larger than the preceding, so that the composite shell has a conical form, the apex of the cone being the original segment, and its base the one last formed. The method of growth now described, is common to a large number of Foraminifera, chiefly belonging to the genera *Nodosaria*, *Dentalina*, and *Marginulina*, which M. D'Orbigny has ranked-together in an order, under the designation of *Stichostegues*; it is, however, frequently seen also in the advanced stages of growth of such as usually begin upon the spiral plan; and there are various considerations (into which this is not the place to enter) which satisfy the Author, that the mere *direction* of increase is a character of very subordinate importance in the group, instead of being one of such fundamental value as to serve for the basis of classification.

286. If each of the successively-formed segments, instead of being developed exactly in the axis of its predecessor, should be directed a little to one side, it is obvious that a curved instead of a straight rod will be produced; and this curvature may increase, until it becomes a spiral (Fig. 205). The character of this spiral will depend in great degree upon

the enlargement or non-enlargement of the successively-formed chambers; for sometimes it opens-out very rapidly, every whorl being considerably broader than that which it surrounds, in consequence of the great excess of the size of each segment over that of its predecessor, as is generally the case in *Cristellaria*; whilst in other instances there is so little difference between the successive segments, after the spiral has made two or three turns, that the breadth of each whorl scarcely exceeds that of its predecessor, as is well seen in *Faujasina* (Fig. 209), as also in *Nummulite* (Chap. XIX.). An intermediate condition is presented by *Rosalina* (Fig. 205), which

FIG. 205.

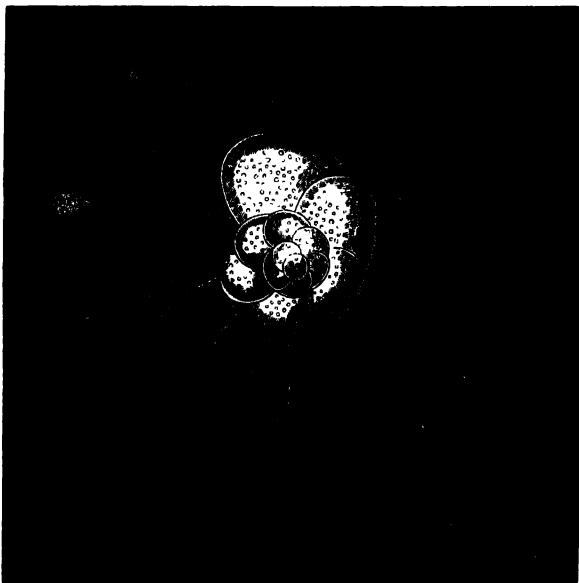
*Rosalina ornata*, with its pseudopodia extended.

may be taken as an example of a very large group of Foraminifera, composed of those whose plan of growth is *helical* or *spiral*, and ranged by M. D'Orbigny under the designation

Helicostègues. In this genus, as in a large proportion of its congeners, we find the shell perforated with numerous apertures, through which pseudopodia can be extended from any of the segments that are not enclosed by others, as well as from the mouth or aperture of the outer segment; and when this is the case, it does not appear that the sarcode-body is so often extended over the exterior of the shell, as it is when the shell has no perforations for the putting-forth of these extensions. There are generally indications, however, in the structure of the shell itself,—new layers being often formed over the innermost whorls of the spiral, or partial deposits being added, sometimes in the shape of bosses, spines, or other outgrowths,—that a soft substance, capable of originating such new formation, must occasionally spread itself over the whole external surface of the previous segments. And it is not difficult to understand how this may come to pass, when it is borne in mind that the gelatinous sarcode, however fine may be the threads into which it divides itself, may readily form a continuous layer by the coalescence of those threads.—The group of *Helicostègues* is subdivided by M. D'Orbigny into two families, the *Nautiloidæ*, and the *Turbinoidæ*; the first and most important consisting of those in which the successive whorls all lie in the same plane, so that the shell is 'equilateral' (like that of a *Nautilus*), as is the case with *Nummulites* and their allies (such as *Nonionina*, *Assilina*, *Operculina*, &c, between which and *Nummulites* the differences are but very slight); whilst the second contains those in which the spiral passes obliquely round an axis, so that the shell becomes 'inequilateral' (like that of a snail or periwinkle), as is the case with *Rotula* (Fig. 335), *Faujasina* (Fig. 209), and *Rosalina* (Fig. 205).

287. Putting aside less important variations in the plan of gemmation, we have now to notice one that seems essentially distinct from the preceding; that, namely, in which the new segments are added in concentric rings, each surrounding its predecessors, so as to form flattened disks. As an example of this curious type of Foraminiferous structure, the *Orbitolite* may be cited; which, long known as a very abundant fossil in the early tertiaries of the Paris basin, has lately proved to be scarcely less abundant in certain parts of the existing ocean. The largest specimens of it, sometimes attaining the size of a sixpence, have hitherto been obtained only from the coast of New Holland and various parts of the Polynesian Archipelago; but disks of comparatively minute size (from the

diameter of an ordinary pin's head, to that of a small pea) and of simpler organisation, are to be found in almost all Foraminiferous sands and dredgings from the shores of the warmer regions of the globe, being especially abundant in those of some of the Philippine Islands, of the Red Sea, of the Mediterranean, and especially of the *Ægean*. When such disks are subjected to Microscopic examination, they are found (if uninjured by abrasion) to present the structure represented in Fig. 206; where we see on the surface (by incident light) a number of rounded elevations, arranged in concentric

FIG. 206.

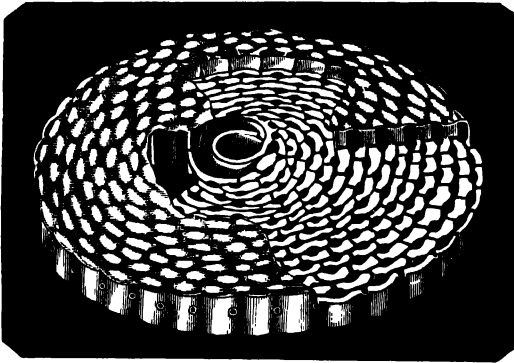

Simple disk of *Orbitolites complanatus*, laid open to show its interior structure:—*a*, central cell; *b*, circumambient cell, surrounded by concentric zones of cells, connected with each other by annular and radiating passages.

circles around a sort of nucleus (which has been laid-open in the figure to show its internal structure); whilst at the margin we observe a row of rounded projections, with a single aperture or pore in each of the intervening depressions. In very thin disks, the structure is often brought into view, by mounting them in Canada balsam, and transmitting light through them, sufficiently well to render any other mode of preparation unnecessary; but in those which are too opaque to be thus seen-through, it is sufficient to rub-down one of the surfaces upon a stone, and then to mount the specimen in balsam. Each of the superficial elevations will then be found

to be the roof or cover of an ovate cavity or cell, which communicates by means of a lateral passage with the cavity on either side of it in the same ring; so that each circular zone of cells might be described as a continuous annular passage, dilated into cavities at intervals. On the other hand, each zone communicates with the zones that are internal and external to it, by means of passages in a radiating direction; and it is curious that these passages run, not from the cells of the inner zone to those of the outer; but from the connecting passages of the former to the cells of the latter, so that the cells of each zone *alternate* in position with those of the zones that are internal and external to it. The radial passages from the outermost annulus make their way at once to the margin, where they terminate, forming the 'pores' which (as already mentioned) are to be seen on its exterior. The central nucleus, when rendered sufficiently transparent by the means just adverted-to, is found to consist of a central cell (*a*), usually somewhat pear-shaped, that communicates by a narrow passage with a much larger circumambient cell (*b*), which nearly surrounds it, and which sends-off a variable number of radiating passages towards the cells of the first zone, which forms a complete ring around the nucleus.*.

288. The idea of the nature of the living occupant of these cavities, which might be suggested by the foregoing account of their arrangement, is fully borne-out by the results of the examination of the sarcode-body, that may be obtained by the maceration in dilute acid (so as to remove the shelly investment) of specimens of *Orbitolite*, that have been gathered fresh from the sea-weeds to which in the living state they are found adherent, and have been kept in spirit. For this body is found to be composed (Fig. 207) of a multitude of segments of 'sarcode,' presenting not the least trace of higher organisation in any part, and connected together by 'stolons' of the like substance. The 'central' pear-shaped segment, *a*, is seen to have budded-off its 'circumambient' segment *b* by a narrow footstalk or stolon; and this circumambient segment, after passing almost entirely round the central one, has budded-off three stolons, which swell into new segments from which the first annulus is formed. Scarcely are any two

* Although the above may be considered the *typical* form of the Orbitolite, yet, in a very large proportion of specimens, the first few zones are not complete circles, the early growth having taken-place rather in a *spiral* than in a *radial* direction; between these two plans, there is every variety of gradation; and even where the spiral is most distinctly marked in the first instance, the additions soon come to be made in concentric zones.

specimens precisely alike, as to the mode in which the first annulus originates from the 'circumambient' segment; for

FIG. 207.

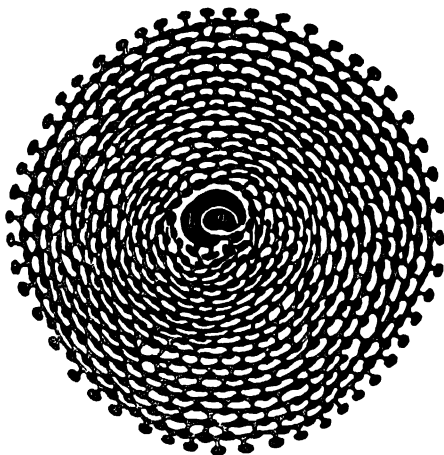

Composite Animal of simple type of *Orbitolites complanatus* :—*a*, central mass of sarcode; *b*, circumambient mass, giving off peduncles, in which originate the concentric zones of segments connected by annular bands.

sometimes a score or more of radial passages extend themselves from every part of the margin of the latter (and this, as corresponding with the plan of growth afterwards followed, is probably the *typical* arrangement), whilst in other cases (as in the example before us) the number of these primary offsets is extremely small. Each zone is seen to consist of an assemblage of ovate segments, whose height (which could not be shown in the figure) corresponds with the thickness of the disk; these segments, which are all exactly similar and equal to one another, are connected by annular 'stolons;' and each zone is connected with that on its exterior, by radial extensions of those stolons, passing-off between the segments.—Although no opportunity has yet been obtained, for a microscopic examination of these animals in their living state, yet there can be no reasonable doubt that the radial extensions of

the outermost zone issue-forth as pseudopodia from the marginal pores; and that they search-for and draw-in alimentary materials, in the same manner as do those of other Foraminifera; the whole of the soft body, which has no communication whatever with the exterior, save through these marginal pores, being nourished by the transmission of the products of digestion from segment to segment and from zone to zone, through similar bands of gelatinous substance. In all cases in which the growth of the disk takes-place with normal regularity, it is probable that a complete circular zone is added at once. When the sarcode-body has increased beyond the capacity of its enveloping disk, it may be presumed that its pseudopodial extensions, proceeding from the marginal pores, coalesce, so as to form a complete annulus of sarcode round the margin of the outermost zone; and it is probable that it is by a deposit of calcareous matter in the surface-portion of this annulus, that the new zone of shelly substance is formed, which constitutes the walls of the cells and passages occupied by the soft sarcode-body.—Thus we find this simple type of organisation giving origin to fabrics of by no means microscopic dimensions, in which, however, there is no other differentiation of parts than that concerned in the formation of the shell; every segment and every stolon (with the exception of the two forming the 'nucleus') being, so far as can be ascertained, a precise repetition of every other, and the segments of the nucleus differing from the rest in nothing else than their form. The equality of the endowments of the segments is shown by the fact, of which accident has repeatedly furnished proof,—that a small portion of a disk, entirely separated from the remainder, will not only continue to live, but will so increase as to form a new disk; the loss of the nucleus not appearing to be of the slightest consequence, from the time that active life is established in the outer zones. In what manner the multiplication and reproduction of the species are accomplished, we can as yet do little more than guess; but from appearances sometimes presented by the sarcode-body, it seems reasonable to infer that 'gemmules,' corresponding with the 'zoospores' of Protophytes (§ 197), are occasionally formed by the breaking-up of the sarcode into globular masses; and that these, escaping through the marginal pores, are sent forth to develop themselves into new fabrics. Of the mode wherein that sexual operation is performed, however, in which alone true Generation consists, nothing whatever is known.

289. One of the most curious features in the history of this

animal, is its capacity for developing itself into a form, which, whilst fundamentally the same as that previously described, is very much more complex. In all the larger specimens of Orbitolite, we observe that the marginal pores, instead of constituting but a single row, form many rows, one above another; and besides this, the cells of the two surfaces, instead of being rounded or ovate in form, are usually oblong and straight-sided, their long diameters lying in a radial direction. When a vertical section is made of such a disk, it is found that these oblong chambers constitute two superficial layers, between which are interposed columnar chambers of a rounded form; and these last are connected together by a complex series of passages, the arrangement of which will be best understood from the examination of a part of the sarcode-

FIG. 208.

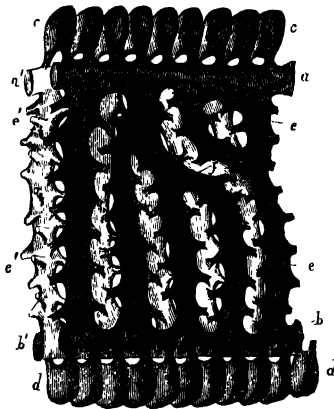

Portion of Composite Animal of complex type of *Orbitolites complanatus* — $a a'$, $b b'$, the upper and lower annular bands of two concentric zones, $c c'$, the upper layer of superficial segments, and $d d'$ the lower layer, connected with the annular bands of both zones; $e e'$ and $e' e'$, vertical segments of the two zones.

($e e'$, $e' e'$) terminate above and below in the annular stolons, sometimes passing directly from one to the other, but sometimes going out of the direct course to coalesce with

body that occupies them (Fig. 208). For the oblong superficial chambers are occupied by segments of sarcode, $c c'$, $d d'$, lying side by side so as to form part of an annulus, but each of them being disconnected from its neighbours, and communicating only by a double footstalk with the two circular stolons $a a'$, $b b'$, which obviously correspond with the single stolon of the simple type (Fig. 207). These indirectly connect together, not merely all the superficial cells of each zone, but also the columnar segments of the intermediate layer; for these columnus

another column. The columns of the successive zones (two sets of which are shown in the figure) communicate with each other by threads of sarcode, in such a manner, that (as in the simple type) each column is thus brought into connection with two columns of the zone next interior, to which it alternates in position. Similar threads, passing-off from the outermost zone, through the multiple ranges of marginal pores, would doubtless act as pseudopodia.—Now this plan of growth is so different from that previously described, that there would at first seem ample ground for distinguishing the *simple* and the *complex* types as two species. But the test furnished by the examination of *a large number of specimens*, which ought never to be passed-by when it can possibly be appealed-to, furnishes these very singular results ;—1st, That the two forms must be considered as specifically identical ; since there is not only a gradational passage from one to the other, but they are often combined in the same individual, the inner and first-formed portion of a large disk frequently presenting the simple type, whilst the outer and later-formed part has developed itself upon the complex.—2nd, That although the last-mentioned circumstance would naturally suggest that the change from the one plan to another may be simply a feature of advancing age, yet this cannot be the case ; since the complex plan sometimes evolves itself even from the very first (the nucleus, though resembling that of the simple form, sending out two or more tiers of radiating threads), whilst, more frequently, the simple prevails for an indefinite number of zones, and then changes itself in the course of a few zones into the complex. The mode in which this change occurs is not a little curious. In the first place, the short segments, threaded (so to speak) upon their annular stolon, undergo elongation, and the annular stolon itself becomes double, being first, as it were, split in two, and its upper and lower halves being separated by the interpolation of a lengthening piece to each columnar segment. These additional pieces are at first very short ; but with the growth of every new zone, they commonly increase in length ; and this interpolated portion comes to constitute the principal part of the thickness of the disk. While this change is going-on, another is taking-place in the position of the superficial portions of the segments which are above and below the annular stolons ; for these, whilst at first seeming to be mere continuations of the columns beneath, and being connected (like them) with the stolons of their own zones alone, are so dis-

placed, in the course of two or three zones, as to arch over the space between the zones (as shown in Fig. 208), and to connect themselves with the stolon, not only of their own zone, but of the next.—It has been thought desirable to enter into the foregoing detail, since a more striking instance could scarcely be drawn from any department of Natural History, of the wide range of variation that may occur within the limits of one and the same species; and the Microscopist needs to be specially put on his guard as to this point in respect to the lower types of Animal, as to those of Vegetable life, since the determination of form seems to be far less precise among such, than it is in the higher types.*

290. The type of Foraminiferous structure which has been just described, is in many respects peculiar, and may be considered as verging towards the Sponges. It is obvious, from what has been said of the extreme freedom with which the several segments of the sarcode-body communicate with each other, that they form *one whole*, in a far greater degree than they do in the ordinary composite Foraminifera, whose segments are more completely separated, and are very commonly connected only by a few very slender threads of sarcode. Indeed if we were to imagine a discoidal mass of sarcode to be traversed by a reticulated calcareous skeleton, somewhat resembling that open arcular texture which forms the *shell* of the *Echinida* (§ 312), and this network were to possess somewhat of that regularity in the disposition of its successively-formed parts, which is presented to us in the *spines* of that group (Fig. 237), we should have no unapt representation of the calcareous skeleton of the Orbitolite, and of its relation to the animal which it envelopes and protects. Now there are certain *Sponges* which have a reticular skeleton composed of mineral matter (§ 296), differing from that of Orbitolite in little else than the want of the zonular arrangement which marks successive epochs of growth; and we shall see that the constitution of the soft body is essentially the same in one case as in the other. A remarkable connecting link between the Orbitolite and certain Sponges, seems, in fact, to be presented to us in the curious *Thalassicolla*,† discovered by Mr. Huxley, and since observed by Prof. Muller, which seems also to have relations to the *Polycystina* (§ 292).

* For a full account of the Organization of the *Orbitolite*, and of the various conditions under which it presents itself, see the Author's memoir upon that genus in "Philos. Transact.," 1856.

† See "Annals of Natural History," 2nd Ser., vol. viii. p. 433; and "Quart. Journ. of Microsc. Science," vol. iv. p. 72.

291. The essential simplicity of the animal, and the absence of anything like structure in the shell, of the Orbitolite, obviously place it much lower in the scale than those Foraminifera, which have the segments not only more completely divided, but enclosed in a shell which is itself distinctly organized. Such is the case with *Nummulites* and their nearest allies among the recent forms. For in these, as will be more fully shown hereafter (Chap. XIX), each segment has its own separate envelope of shell, so that the partition between any two adjacent chambers is double; the chambers are so far cut-off from one another, as to communicate only by very narrow passages; but means are afforded, by which even the innermost chambers are brought into tolerably-direct relation with the exterior. For in this type of structure, we observe that those parts of their walls which look towards the outer surfaces, are perforated with immense numbers of pores resembling those of Fig. 205, but more numerous, minute, and closely-set; and where the walls are thick, these pores are continued as tubes through their entire substance (Figs. 209, 338). However fine they may be, the extraordinary tenuity of the threads into which the sarcode is occasionally seen to divide itself (Fig. 204), shows that this need not be an obstacle to the passage of pseudopodial prolongations through them. But further, in the spaces between the walls of contiguous chambers, we find a system of large tubes, which make their way directly from the central to the peripheral portion of the disk, and which, communicating on the one hand with the innermost chambers, and on the other with the margin (being extended and carried-on to it whenever the previous edge is covered by a new growth), serve to bring the former into very direct relation with the external sources of supply of nutriment and oxygen. A strikingly-developed example of this system of 'interseptal' canals is presented in the genus *Favosina* (Fig. 209);* where the large size of the

* See Prof. Williamson's Memoir on the *Favosina*, in the "Transact. of Microsc. Soc.," 2nd Ser., vol. 1.—As the correctness of the account of the interseptal system of canals, which has been given by the Author (in his Memoir on Nummulite, &c., in "Quart. Geol. Journ.," Feb., 1850), and confirmed by the researches of Prof. W. and himself upon numerous recent types, has been called in question by no less an authority than Prof. Schulze, who has, in consequence, altogether ignored this important character in his classification, the Author thinks it right to state, that although the above figure is copied from one of those which illustrate Prof. Williamson's Memoir, yet it is the almost precise counterpart of a section of the same species prepared by himself. The incredulity of Prof. Schulze and others, upon this point, simply depends upon their want of aptitude in the preparation of sufficiently-thin sections.

canals, and the extreme simplicity of their arrangement, enable them to be very readily traced-out. In some instances the arrangement becomes extremely complex: this is especially the case, where, as frequently happens, there is an interstitial calcareous skeleton to be nourished (often

FIG. 209.

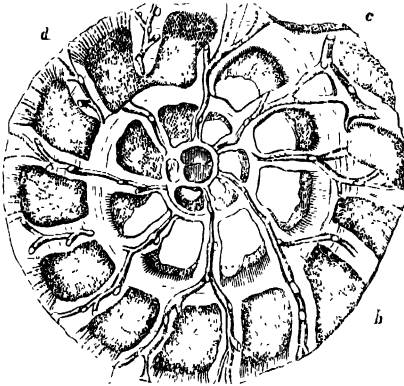

Section of *Fujasina* near its base and parallel to it—showing, *a a*, the radiating interseptal canals; *b*, their internal bifurcations; *c*, a transverse branch; *d*, tubular wall of the chambers.

extending itself into outgrowths of various forms and sizes), in addition to the immediate investments of the segments; and it becomes obvious from the far greater development of this canal system wherever such is the case, that this interstitial skeleton is chiefly if not entirely maintained through the instrumentality of the 'stolons' of sarcodæ which occupy these canals, and whose remains

may often be distinctly traced in the dried shell.* Now this, the *highest* type of Foraminiferous structure, is not only presented by such spiral forms as Nummulite, but is found also in a genus that is conformable, in its concentric plan of growth, to Orbitolite. Hence it is obvious that no arrangement founded, as is that of M. D'Orbigny, upon a character of such secondary importance as the direction of gemination, is likely to be in accordance with physiological features which a perfect knowledge of the animal might be

* The Author has been enabled to make-out this curious point completely, in the *Calcarina*, a little body resembling a spur-rowel. For he has obtained ample evidence that the *spire* with its regularly-added segments, and the *interstitial skeleton* extending itself into radiating spines, may grow quite independently of one another. The proof will be submitted in future Memoirs to the Royal Society.

expected to afford; and as these can be partly judged-of from the structure of the shell, it seems obvious that this ought to be made the first consideration. To carry-out a classification on such a basis, however, will involve a large amount of patient investigation.*

292. Many of the Foraminifera attach themselves in the living state to Sea-weeds, Zoophytes, &c.; and they should, therefore, be carefully looked-for on such bodies, especially when it is desired to observe their internal organisation and their habits of life. They are often to be collected in much larger numbers, however, from the sand or mud dredged-up from the sea-bottom, or even from that taken from between the tide-marks. In a paper containing some valuable hints on this subject,† Mr. Legg mentions that, in walking over the Small Mouth Sand, which is situated on the north side of Portland Bay, he observed the sand to be distinctly marked with white ridges, many yards in length, running parallel with the edge of the water; and upon examining portions of these, he found Foraminifera in considerable abundance. One of the most fertile sources of supply that our own coasts afford, is the 'ouze' of the Oyster-beds, in which large numbers of living specimens will be found; the variety of specific forms, however, is usually not very great. In separating these bodies from the particles of sand, mud, &c., with which they are mixed, various methods may be adopted, in order to shorten the tedious labour of picking them out, one by one, under the Simple Microscope; and the choice to be made among these will mainly depend upon the condition of the Foraminifera, the importance (or otherwise) of obtaining them alive, and the nature of the substances with which they are mingled.— Thus, if it be desired to obtain living specimens from the oyster-ouze, for the examination of their soft parts, or for preservation in a vivarium, much time will be saved by stirring the mud (which should be taken from the surface only of the deposit) in a jar with water, and then allowing it to stand for a few moments; the finer particles will remain diffused through the liquid, while the heavier will subside; and as the Foraminifera (in the present case) belong to the latter category, they will be found almost entirely free from extraneous matter, at the bottom of the vessel, after the operation has been repeated

* To this labour, the Author has been for some years devoting a portion of his very limited leisure, in conjunction with his friend Prof. Williamson of Manchester; and the results of their united labours will appear at the earliest practicable period, in the Ray Society's publications.

† "Transactions of the Microscopical Society," 2nd Series, vol. ii. p. 19.

two or three times. It would always be well to examine the first deposit let-fall by the water that has been poured-away; as this may contain the smaller and lighter forms of Foraminifera.—But supposing that it be only desired to obtain the dead shells from a mass of sand brought-up by the dredge, a very different method should be adopted. The whole mass should be exposed for some hours to the heat of an oven, and be turned-over several times, until it is found to have been thoroughly dried throughout; and then, after being allowed to cool, it should be stirred in a large vessel of water. The chambers of their shells being now occupied by air alone (for the bodies of such as were alive will have shrunk-up almost to nothing), the Foraminifera will be the lightest portion of the mass; and they will be found floating on the water, while the particles of sand, &c., subside.—Another method, devised by Mr. Legg, consists in taking advantage of the relative sizes of different kinds of Foraminifera and of the substances that accompany them. This, which is especially applicable to the sand and rubbish obtainable from sponges (which may be got in large quantity from the sponge-merchants), consists in sifting the whole aggregate through successive sieves of wire-gauze, commencing with one of 10 wires to the inch, which will separate large extraneous particles, and proceeding to those of 20, 40, 70, and 100 wires to the inch, each (especially that of 70) retaining a much larger proportion of Foraminiferous shells than of the accompanying particles; so that, a large portion of the extraneous matters being thus got-rid-of, the final selection becomes comparatively easy.—Certain forms of Foraminifera are found attached to shells, especially bivalves (such as the *Chamaceæ*), with foliated surfaces; and an extensive examination of those of the Indian Seas, when brought home ‘in the rough,’ has yielded to Mr. W. K. Parker some most valuable and novel results, which will be made public in due time.

293. The final selection of specimens for mounting, should always be made under some appropriate form of Single Microscope (§§ 27—30); a fine camel-hair pencil, with the point wetted between the lips, being the instrument which may be most conveniently and safely employed, even for the most delicate specimens. In mounting Foraminifera as microscopic objects, the method to be adopted must entirely depend upon whether they are to be viewed by transmitted or by reflected light. In the former case, they should be mounted in Canada-balsam; the various precautions to prevent the retention of

air-bubbles, which have been already described (§ 128), being carefully observed. In the latter, no plan is so simple, easy, and effectual, as the attaching them with a little gum to a blackened disk of card, and guarding them by a perforated wooden slide (§ 123). They should be fixed in various positions, so as to present all the different aspects of the shell, particular care being taken that its mouth is clearly displayed; and where, as will often happen, the several individuals differ considerably from one another, special care should be taken to form *series* illustrative of their range of variation, and of the mutual connections of even the most diverse forms.—For the display of the internal structure of Foraminifera, it will often be necessary to make extremely thin sections, in the manner already described (§§ 108—110); and much time will be saved, by attaching a number of specimens to the glass at once, and by grinding them down together. For the preparation of sections, however, of the extreme thinness that is often required, those which have been thus reduced should be transferred to separate glasses, and finished-off each one by itself.

294. *Polycystina*.—It is probable that we are to refer to the same general type, an extensive group of very interesting microscopic bodies, possessing great beauty and variety of form and structure (Figs. 210—216), of whose essential character extremely little is known. These are minute siliceous shells, which appear, from the recent observations of Prof. Muller, to contain in the living state an olive-brown 'sarcodé,' extending itself into pseudopodial prolongations (resembling those of Actinophrys, § 262), that pass through the large apertures by which the shells are perforated. The sarcodé-body does not seem always to fill the shell; being stated by Prof. Muller to occupy, in the *Eucyrtidium* of Messina, only the upper part or vault of the shell, and to be very regularly divided into four lobes. It is a peculiar feature in these *Polycystina*, that their shells are often prolonged into spines or other projections, which are sometimes arranged in such a manner as to give them a very singular aspect (Figs. 210, 211). It seems probable that these creatures are almost as widely diffused at the present time, as are the Foraminifera; although, from their greater minuteness, they have not been so often recognized. For having been first discovered by Prof. Ehrenberg at Cuxhaven on the North Sea, they were afterwards found by him in collections made in the Antarctic Seas, and have been recently described by Prof.

Bailey as presenting themselves (with Foraminifera and Diatomaceæ) in the deposits brought-up by the sounding-lead

FIG. 210.

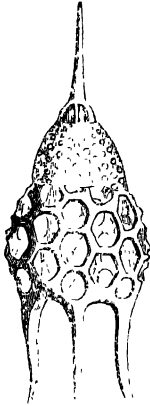

FIG. 211.

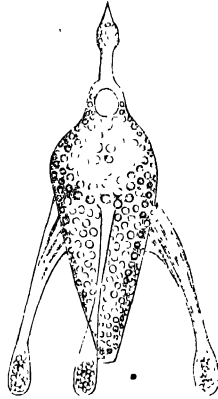

FIG. 210. *Podocyrta Schomburgku*.
FIG. 211. *Rhopalocanium ornatum*.

from the bottom of the Atlantic Ocean, at depths of from 1000 to 2000 fathoms. They appear to have been much more abundant, however, during the later geological periods; for not only have certain forms (among them *Haliomma*, Fig. 212)

FIG. 212.

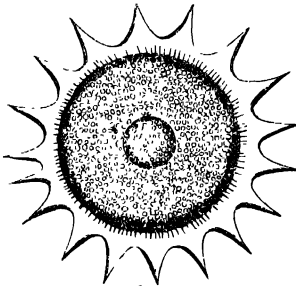

FIG. 213.

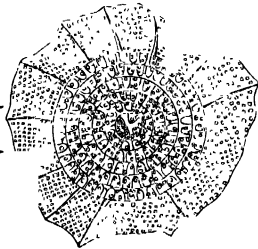
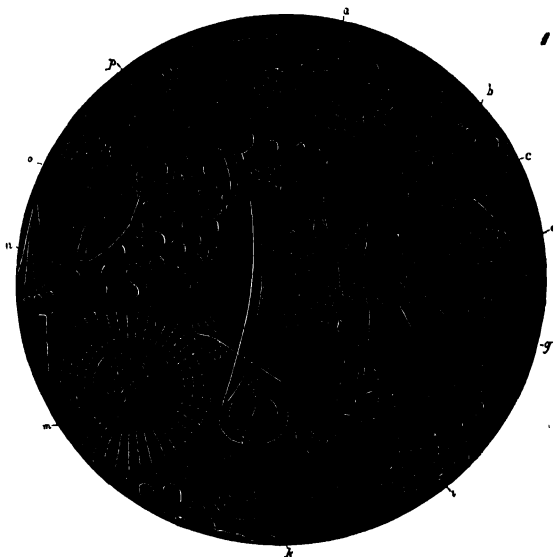

FIG. 212. *Haliomma Humboldtii*.
FIG. 213. *Perichlamydidium prætextum*.

been detected by Prof. Ehrenberg in the chalks and marls of Sicily and Greece, and of Oran in Africa, and also in the diatomaceous deposits of Bermuda and Richmond (Virginia); but a large proportion of the rock that prevails through an extensive district in the island of Barbadoes, has been found by him to be composed of Polycystina, mingled with Diatomaceæ,

FIG. 214.



Fossil *Polycystina*, &c., from Barbadoes—*a*, *Podocyrus mitra*; *b*, *Rhabdolithes sceptrum*; *c*, *Lychnocanium faleiferum*; *d*, *Encyrtidium tubulus*; *e*, *Flustrella concentrica*, *f*, *Lychnocanium lucerna*; *g*, *Encyrtidium elegans*; *h*, *Dietyospyris clathrus*, *i*, *Encyrtidium mongolieri*; *k*, *Stephanolithes spinescens*; *l*, *S. nodosa*; *m*, *Lithocyclia ocellus*; *n*, *Cephalolithes sylvina*; *o*, *Podocyrus cothurnata*; *p*, *Rhabdolithes pipa*.

with a few calcareous Foraminifera, and with calcareous earth which was probably derived from the decomposition of corals, &c., so as to form, according to the relative proportions of these constituents (which differed in different parts of the deposit), a tripoli-like sandstone, whitish and very friable, a compact calcareous sandstone, and strata of a marly cha-

racter sometimes containing semi-opal. Previously to this last discovery, which was made in the year 1846 (the materials having been furnished by the geological researches of Sir R. H. Schomburgk), 39 species of Polycystina had been established by Prof. E.; but in the Barbadoes deposit, he has detected no fewer than 282 forms which he considers to be specifically distinct, besides 25 species of Diatomaceæ and Foraminifera, and 54 forms which he cannot distinctly determine, but which he classes under the provisional designations of *Geolitharia* and *Phytolitharia*, making 361 in all, of which

FIG. 215.

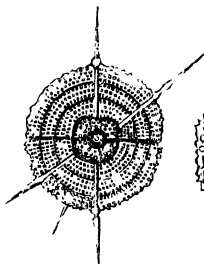

FIG. 216.

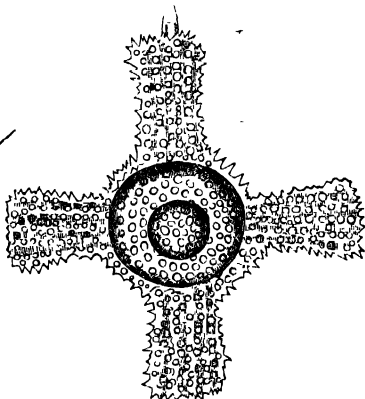

FIG. 215. *Stylodictya gracilis*.
 FIG. 216. *Astromma Aristotelis*.

more than 300 were previously unknown. The 282 species of Polycystina are arranged by Prof. E. in seven families, which include forty-four genera; but it is obvious that in our present state of almost entire ignorance of the structure and physiology of the animals to which these shells belong, no classification can be otherwise than provisional.—Few Microscopic objects are more beautiful than an assemblage of the most remarkable forms of the Barbadian *Polycystina*, especially when seen brightly illuminated upon a black ground; since (for the reason formerly explained, § 62) their ‘solid forms’ become much more apparent than they are when these objects are examined by light transmitted through them. And the

'black-ground illumination,' either by the 'spotted lens' or by the 'paraboloid' (§ 61), is much to be preferred for this purpose, to the ordinary mode of illuminating opaque objects by incident light from a condenser, although this may be advantageously had-recourse-to, by the Microscopist who is unprovided with these appurtenances. No class of objects is more suitable than these to the 'Binocular Microscope' (§ 40); the stereoscopic projection of which causes them to be presented to the mind's eye in complete relief, so as to bring-out with the most marvellous and beautiful effect, all their delicate sculpture, reminding the observer (to compare small things with great) of the finest specimens of the hollow ivory balls carved by the Chinese *

295. *Sponges*.—Although this tribe has been bandied from the Animal to the Vegetable kingdom, and back again, several times in succession, yet its claim to a place among the Protozoa may now be considered as pretty certainly determined, by the information derived from Microscopic examina-

FIG. 217.

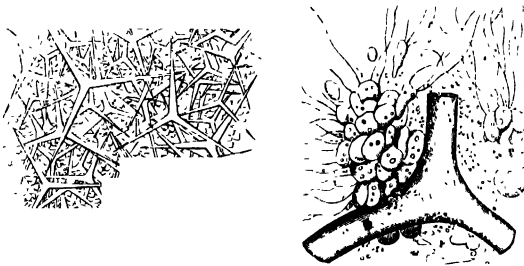

Structure of *Grantia compressa*:—A, portion moderately magnified, showing general arrangement of triradiate spicules and intervening tissue;—B, small portion highly magnified, showing ciliated cells.

tion of its minute structure. For in the living Sponge, the skeleton, usually composed of a fibrous network strengthened by spicules of mineral matter, is clothed with a soft flesh;

* For a fuller description of this group, see Prof. Ehrenberg's Memoirs in the "Transactions of the Berlin Academy" for 1846, 1847, and his recently-published "Microgeologie;" also "Ann. of Nat. Hist.," 1847.

and this flesh has been found by Dujardin and all subsequent observers to consist of an aggregation of *Amœba*-like bodies (Fig. 217, B), some of which (as Mr. Dobie has shown*) are furnished with one or more long cilia, closely resembling those of *Volvox* (Fig. 70, 1), by the agency of which, a current of water is kept-up through the passages and canals excavated in the substance of the mass. And from the observations of Mr. Carter† upon the early development of Sponges, it appears that they begin life as solitary *Amœbæ*, and that it is only in the midst of aggregations formed by the multiplication of these, that the characteristic *Sponge*-structure makes its appearance, the formation of spicules being the first indication of such organisation. The ciliated cells seem to form the walls of the canals by which the whole fabric of the Sponge is traversed; these canals, which are very irregular in their distribution, may be said to commence in the small pores of the surface, and to terminate in the large vents; and a current is continually entering at the former, and passing-forth from the latter, during the whole life of the Sponge, bringing-in alimentary particles and oxygen, and carrying out excrementitious matter.

296. The skeleton which gives shape and substance to the mass of sarcode-particles that constitutes the living animal, is composed, in the Sponges with which we are most familiar, of an irregular reticulation of fibres. The arrangement of these may be best made-out, by cutting thin slices of a piece of Sponge submitted to firm compression, and viewing these slices, mounted upon a dark ground, with a low magnifying power, under incident light. Such sections, thus illuminated, are not merely striking objects, but serve to show, very characteristically, the general disposition of the larger canals and of the smaller arcolæ with which they communicate. In the ordinary Sponge, the fibrous skeleton is almost entirely destitute of spicules, the absence of which, in fact, is one important condition of that flexibility and compressibility on which its uses depend. When spicules exist in connection with such a skeleton, they are either altogether imbedded in the fibres, or they are implanted into them at their bases, as shown in Fig. 218. In the curious and beautiful *Dictyochalina plumiceus* of Barbadoes, however, the entire network of fibres is composed of siliceous matter, and is so transparent that it looks as if composed of spun glass. There are many Sponges in which no fibrous network can be discerned, the spicules lying im-

* "Goodsir's Annals of Anatomy and Physiology," No. 2, May, 1852.

† "Annals of Natural History," Ser. 2, vol. iv.

bedded in the midst of the sarcode-mass; such is the case in *Grantia* (Fig. 217, A), whose triradiate spicules are composed of carbonate of lime. Sponge-spicules are much more frequently siliceous than calcareous; and the variety of forms presented by the siliceous spicules is much greater than that which we find in the comparatively small number of species in which they are composed of carbonate of lime. The long needle-like spicules (Fig. 219) which are extremely abundant in several Sponges, lying close together in bundles, are sometimes straight, sometimes slightly curved; they are sometimes pointed at both ends, sometimes at one only; one or both ends may be furnished with a head like that of a pin, or may carry three or more diverging points which sometimes curve-back so as to form hooks (Fig. 334, u). When the spicules project from the horny framework, they are usually somewhat conical in form, and their surface is often beset with little spines, arranged at regular intervals, giving them a jointed appearance (Fig. 218). Sponge-spicules frequently occur, however, under forms very different from the preceding; some being short and many-branched, and the branches being themselves very commonly stunted into mere tubercles (some examples of which type are presented in Fig. 334, A, c); whilst others are stellate, having a central body with conical spines projecting from it in all directions (as at d of the same figure). Great varieties present themselves in the stellate form, according to the relative predominance of the body and of the rays; in those represented in Fig. 219, the rays, though very numerous, are extremely short; in other instances the

FIG. 218.



Portion of *Halichondria* (?) from Madagascar, with spicules projecting from the fibrous network.

rays are much longer, and scarcely any central nucleus can be said to exist. The varieties in the form of Sponge-spicules are, in fact, almost endless; and a single sponge often presents two or more (as shown in Fig. 219), the *stellate* spicules

FIG. 219.

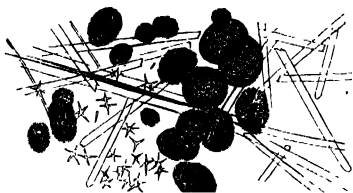
Siliceous Spicules of *Pachymatisma*.

usually occurring either in the interspaces between the elongated kinds, or in the external crust. In one curious Sponge described by Mr. Bowerbank (the *Dusideia fragilis*), the spicules are for the most part replaced by particles of sand, of very uniform size, which are found imbedded in the horny fibre. —The spicules of Sponges cannot be considered, like the ‘raphides’ of Plants (§ 230), simply as deposits of mineral matter in a crystalline state. For the forms of many of them are such as no mere crystallization can produce; many of them possess internal cavities, which contain organic matter; and the calcareous spicules, whose mineral matter can be readily dissolved-away by an acid, are found to have a distinct animal basis. Hence it seems probable, that each spicule was originally a cell or segment of sarcode, which has undergone calcification, and by the self-shaping power of which, the form of the spicule is mainly determined.

297. Of the Reproductive process in Sponges, much has yet to be learned:—the following is perhaps the most probable account of it. Multiplication by gemination is effected by the detachment of minute globular particles of sarcode from the interior of the canals, where they sprout-forth as little protuberances, whose footstalks gradually become narrower and narrower until they give way altogether; these *gemmules*, like the zoospores of Algae, possess cilia, and issuing forth from the vents, transport themselves to distant localities, where they may lay the foundation of new fabrics. But according to the recent observations of Mr. Huxley,* a true sexual generation also takes-place, as might be anticipated; both ova and sperm-cells being found imbedded in the substance of the Sponge. The bodies distinguished as *capsules*,

* “Ann. of Nat. Hist.,” Ser. 2, vol. vii.

which are larger than the gemmules, and which usually have their investment strengthened with siliceous spicules very regularly disposed, are probably the products of this operation. They contain numerous globular particles of sarcode, every one of which, when set-free by the rupture of its envelope, becomes an independent Amœba-like body, and may develope itself into a complete Sponge.

298. With the exception of those that belong to the genus *Spongilla*, all known Sponges are marine; but they differ very much in habit of growth. For whilst some can only be obtained by dredging at considerable depths, others live near the surface, whilst others attach themselves to the surfaces of rocks, shells, &c. between the tide-marks. The various species of *Grantia*, in which alone of all the marine Sponges has ciliary movement yet been seen, belong to this last category. They have a peculiarly simple structure, each being a sort of bag whose wall is so thin that no system of canals is required, the water absorbed by the outer surface passing directly towards the inner, and being expelled by the mouth of the bag. The cilia may be plainly distinguished with a 1-8th in. objective, on some of the cells of the gelatinous substance scraped from the interior of the bag; or they may be seen *in situ*, by making very thin transverse sections of the substance of the Sponge.* It is by such sections alone, that the internal structure of Sponges, and the relation of their spicular and horny skeletons to their fleshy substance, can be demonstrated. In order to obtain the spicules in an isolated condition, however, the animal matter must be got-rid-of, either by incineration, or by chemical reagents. The latter method is preferable, as it is difficult to free the mineral residue from carbonaceous particles by heat alone. If (as is commonly the case) the spicules are siliceous, the Sponge may be treated with strong nitric or nitro-muriatic acid, until its animal substance is dissolved-away; if, on the other hand, they be calcareous, a strong solution of potass must be employed instead of the acid. The operation is more rapidly accomplished by the aid of heat; but if the saving of time be not of importance, it is preferable on several accounts to dispense with it. The spicules, when obtained in a separate state, should be mounted in Canada balsam.—Sponge-tissue may often be distinctly recognized in sections of agate, chalcedony, and other siliceous accretions, as will hereafter be stated in more detail (Chap. XIX.).

* See Dobe, loc. cit.; and Bowerbank in "Trans. of Microsc. Soc." 1st Ser. vol. iii. p. 137.

CHAPTER XI.

ZOOPHYTES.

299. THE term Zoophyte, although sometimes used in a wider signification, is properly restricted to the class of *Polypifera*, or polype-bearing animals, whose composite skeletons or 'polyparies' have more or less of a plant-like form; even the *Polyzoa* (or Bryozoa) being now excluded, on account of their truly Molluscan structure (Chap. XIII.), notwithstanding the zoophytic character of their forms and of their habits of life.—The true Zoophytes may be divided into two primary groups, the *Hydrozoa* and the *Anthozoa*; the *Hydra* (or fresh-water polype) standing as the type of the one, and the *Sea-Anemone* as the representative of the other. As the Hydrozoa are essentially microscopic animals, they need to be described with some minuteness; whilst in regard to the Anthozoa, only those points can be dwelt-on, which are of special interest to the Microscopist.

300. The *Hydra* is to be searched-for in pools and ditches, where it is most commonly to be found attached to the leaves or stems of aquatic plants, floating pieces of stick, &c. Two species are common in this country, the *H. viridis* or green polype, and the *H. vulgaris*, which is usually orange-brown, but sometimes yellowish or red (its colour being liable to some variation according to the nature of the food on which it has been subsisting); a third less common species, the *H. fusca*, is distinguished from both the preceding by the length of its tentacula, which in the former are scarcely as long as the body, whilst in the latter they are, when fully extended, many times longer (Fig. 220). The body of the Hydra consists of a simple bag or sac, which may be regarded as a stomach, and which is capable of varying its shape and dimensions in a very remarkable degree; sometimes extending itself in a straight line, so as to form a long narrow cylinder, at other times being seen (when empty) as a minute contracted globe, whilst, if distended with food, it may present the form of an inverted flask or bottle, or even of a button.

At the upper end of this sac is a central opening, the 'mouth,' and this is surrounded by a circle of tentacula or 'arms,' usually from six to ten in number, which are arranged with great regularity around the orifice. The body is prolonged at its lower end into a narrow base, which is furnished with a suctional disk; and the Hydra usually attaches itself by this, whilst it allows its tendril-like tentacula to float freely in the water, like so many fishing-lines. The wall of the body is composed of cells, imbedded in a kind of sarcode; and it consists of two principal layers, an outer and more compact, of which the cells form a tolerably-even surface, and an inner that lines the stomach, into the cavity of which some of the cells project. Between these layers, there is a space chiefly occupied by 'sarcode,' having many vacuoles or lacunæ (which

often seem to communicate with one another) excavated in its substance. The arms are made-up of the same materials as the body; but their surface is beset with little wart-like prominences, which, when carefully examined, are found to be composed of clusters of small 'thread-cells,' having a single

FIG. 220.



Hydra fusca, with a young bud at *b*, and a more advanced bud at *c*.

large cell with a long spiculum in the centre of each. The structure of these thread-cells or 'urticating organs' will be described hereafter (§ 310); at present it will be enough to point-out, that this apparatus, repeated many times on each tentacle, is doubtless intended to give to the organ a great prehensile power; the minute filaments forming a rough surface, adapted to prevent the object from readily slipping out of the grasp of the arm, whilst the central spiculum is projected into its substance, and probably conveys into it a poisonous fluid secreted by a vesicle at the base of the dart. The latter inference is founded upon the oft-repeated observation, that if the living prey seized by the tentacles have a body destitute of hard integument, as is the case with the minute aquatic Worms which constitute a large part of its aliment, this speedily dies, even if, instead of being swallowed, it escapes from their grasp; on the other hand, minute Entomostracous Crustacea, Insects, and other animals with hard envelopes, may escape without injury, even after having been detained for some time in the polype's embrace. The contractility of the tentacula (the interior of which is traversed by a canal which communicates with the cavity of the stomach) is very remarkable, especially in the *Hydra fusca*; whose arms, when extended in search of prey, are not less than seven or eight inches in length; whilst they are sometimes so contracted, when the stomach is filled with food, as to appear only like little tubercles around its entrance. By means of these instruments, the Hydra is enabled to derive its subsistence from animals, whose activity, as compared with its own slight powers of locomotion, might have been supposed to remove them altogether from its reach; for when, in its movements through the water, a minute worm or a water-flea happens to touch one of the tentacula of the polype, spread-out as these are in readiness for prey, it is immediately seized by this, other arms are soon coiled around it, and the unfortunate victim is speedily conveyed to the stomach, within which it may frequently be seen to continue moving for some little time. Soon, however, its struggles cease, and its outline is obscured by a turbid film, which gradually thickens, so that at last its form is wholly lost. The soft parts are soon completely dissolved, and the harder indigestible portions are rejected through the mouth. A second orifice has been observed at the lower extremity of the stomach; but this would not seem to be properly regarded as anal, since it is not used for the discharge of such exuvie; it is probably

rather to be considered as representing, in the Hydra, the entrance to that ramifying cavity, which, in the compound Hydroïda, brings into connection the lower extremities of the stomachs of all the individual polypes (Fig. 223).—A striking proof of the simplicity of the structure of the Hydra, is the fact that it may be turned inside-out like a glove; that which was before its external tegument becoming the lining of its stomach, and *vice versâ*.

301. The ordinary mode of multiplication in this animal, is by a gemmation resembling that of Plants. Little bud-like processes (Fig. 220, *b*, *c*) are developed from its external surface, which are soon observed to resemble the parent in character, possessing a digestive sac, mouth, and tentacula; for a long time, however, their cavity is connected with that of the parent, but at last the communication is cut-off by the closure of the canal of the foot-stalk, and the young Polype quits its attachment and goes in quest of its own maintenance. A second generation of buds is sometimes observed on the young Polype, before quitting its parent; and as many as nineteen young Hydræ, in different stages of development, have been seen thus connected with one original stock (Fig. 221). Another very curious endowment seems to depend on the same condition,—the extraordinary power

FIG. 221.

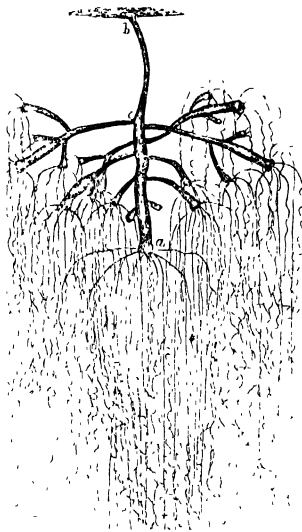

Hydra fuscæ in gemmation; *a*, mouth; *b*, base; *c*, origin of one of the buds.

which one portion possesses of reproducing the rest. Into whatever number of parts a *Hydra* may be divided, each may retain its vitality, and give origin to a new and entire fabric; so that thirty or forty individuals may be formed by the section of one.—The *Hydra* also propagates itself, however, by a truly Sexual process; the fecundating apparatus, or vesicle producing ‘sperm-cells,’ and the ovum (containing the ‘germ-cell,’ imbedded in a store of nutriment adapted for its early development), being evolved in the substance of the walls of the stomach, the former just beneath the arms, the latter nearer to the lower end of the body. It would appear that sometimes one individual *Hydra* develops only the male cysts or sperm-cells, while another develops only the female cysts or ovisacs; but the general rule seems to be, that the same individual forms both organs. The fertilisation of the ova, however, cannot take-place until after the rupture of the spermatie cyst and that of the ovisac also; so that the parent has no further participation in it, than has the *Fucus* in the analogous fertilisation of its germ-cells after their discharge (§ 205). Although the production, from such an egg, of a new *Hydra*, similar in all respects to its parent, has not yet been witnessed, there seems no reason to doubt the fact. It would seem that this alternation in the method of reproduction, between the gemmiparous and the sexual, is greatly influenced by external temperature; the eggs being produced at the approach of winter, and serving to regenerate the species in the spring, the parents not being able to survive the cold season; whilst the budding-process naturally takes place only during the warmer part of the year, but may be made to continue through the whole winter, by keeping the water inhabited by the polypes at a sufficiently high temperature.—The *Hydra* possesses the power of free locomotion, being able to remove from the spot to which it has attached itself, to any other that may be more suitable to its wants; its changes of place, however, seem rather to be performed under the influence of *light*, towards which the *Hydra* seeks to move itself, than with reference to the search after food.

302. Some of the simpler forms of the composite *Hydrozoa* may be likened to a *Hydra*, whose gemmæ, instead of becoming detached, remain permanently connected with the parent; and as these in their turn may develop gemmæ from their own bodies, a structure of more or less arborescent character may be produced. The form which this will present, and the relation of the component polypes to each other, will depend

upon the mode in which the gemmation takes-place; in all instances, however, the entire cluster is produced by continuous growth from a single individual; and the stomachs of the several polypes are united by tubes, which proceed from the base of each, along the stalk and branches, to communicate with the cavity of the central stem.—This is the case with the family *Corynidae*, which are composite fabrics, sometimes quite arborescent in form, but unpossessed of any firm investment, the external wall being only strengthened by a thin horny cuticle. A very beautiful marine species of this family, (the *Coryne pusilla*), is common on sea-weeds and stones between tide-marks; sometimes clustering parasitically round the stalks of *Tubularia* so as to form a thick beard-like mossiness; each aggregate structure, however, not being more than an inch in length. The tentacula (as in Fig. 222, A) are short, and arise from the whole surface of the body of the polype, instead of from the margin of the mouth alone; and at first it seems difficult to understand how they can be of service in bringing food to the mouth, which is situated at the very extremity of the branch. Observation of the living animal, however, soon removes this difficulty; for the head is so very flexible, that the mouth can bend itself down towards any of the tentacula which may have entrapped prey; all its movements are performed, however, in a very leisurely manner. The fresh-water genus *Cordylophora* has yet been only found in a few localities; and the chief interest attaching to it is derived from the fact of its having been made the subject of an admirable Memoir by Prof. Allman,* to which every one should refer, who desires to acquaint himself with the minute organization of this group of Zoophytes.—The phenomena of the Reproductive process exhibited by these Hydrozoa, are extremely curious. In *Coryne* and its allies, besides the ordinary gemmation which extends the original fabric, certain gemmæ are developed, which gradually come to present an organization altogether comparable to that of the simpler *Medusæ* (Fig. 222, B), and which, when detached, swim freely away. These, there is good reason to believe, stand in the same relation to the ordinary polype-buds, as the flower-buds of a plant do to its leaf-buds; each medusa-bud containing either male or female sexual organs, and performing its part in the sexual act, after it has been set-free from the polype-structure that bore it, just as the male (or stamiferous) flower of the *Vallisneria spiralis* discharges its pollen upon the

* "Philos. Transact.," 1853.

female (or pistilline) flower, whilst floating on the surface of the water, after it has broken itself off from the stem. The ova thus fertilized, being deposited by the free-swimming Medusa-buds, evolve themselves (it is probable) into single

FIG. 222.



Development of Medusa-buds in *Syncoryna Sarsii*.—A, an ordinary polype, with its club-shaped body covered with tentacula—B, a polype putting-forth medusan gemma; a, a very young bud; b, a bud more advanced, the quadrangular form of which, with the four nuclei whence the cirrhi afterwards spring, is shown at d; c, a bud still more advanced.

polypes, from every one of which there is gradually produced by continuous gemmation a composite fabric, that in its turn develops Medusa-buds, whose offspring resume the polype-form. In *Cordylophora*, instead of detached Medusa-buds, peculiar capsules sprout-forth from the stem, some of which contain sperm-cells, and others ova; and the spermatozoa set-free from the former enter the ovigerous capsules and fertilize their ova, after the fashion of *Faucheria* (§ 197). The fertilized ova undergo 'segmentation' according to the ordinary type, the whole yolk-mass subdividing successively into 2, 4, 8, 16, 32 or more parts, until a 'mulberry mass' is formed; this then begins to elongate itself, the surface becoming smooth, and showing a transparent margin; and this surface becomes covered with cilia, by whose agency these little bodies, now called 'gemmules,' first move-about within the capsule, and then swim-forth

polypes, from every one of which there is gradually produced by continuous gemmation a composite fabric, that in its turn develops Medusa-buds, whose offspring resume the polype-form. In *Cordylophora*, instead of detached Medusa-buds, peculiar capsules sprout-forth from the stem, some of which contain sperm-cells, and others ova; and the spermatozoa set-free from the former enter the ovigerous capsules and fertilize their ova, after the fashion of *Faucheria* (§ 197). The fertilized ova undergo 'segmentation' according to the ordinary type, the whole yolk-mass subdividing successively into 2, 4, 8, 16, 32 or more parts, until a 'mulberry mass' is formed; this then begins to elongate itself, the surface becoming smooth, and showing a transparent margin; and this surface becomes covered with

freely when liberated by the opening of its mouth. At this period, the embryo can be made-out to consist of an outer and an inner layer of cells, with a hollow interior; after some little time, the cilia disappear, one extremity becomes expanded into a kind of disk by which it attaches itself to some fixed object; a mouth is formed, and tentacula sprout-forth around it; and the body increases in length and thickness, so as gradually to acquire the likeness of one of the parent polypes, after which the plant-like structure characteristic of the genus is gradually evolved, by the successive development of polype-buds from the first-formed polype and its subsequent offsets.*

303. In the family *Tubulariæ*, the long polype-stems are invested by tubular horny sheaths; but these stop-short below the polype-heads, which are consequently unprotected; and the reproductive gemmæ bud-forth, as in the preceding case, from the base of the tentacula. The most common form of this family is the *Tubularia indivisa*, which receives its specific name from the infrequency with which branches are given-off from the stems, these for the most part standing erect and parallel, like the stalks of corn, upon the base to which they are attached. This beautiful zoophyte, which sometimes grows between the tide-marks, but is more abundantly obtained by dredging in deep water, often attains a size which renders it scarcely a microscopic object; its stems being sometimes no less than a foot in height, and a line in diameter. Several curious phenomena, however, are brought into view by microscopic examination. The polype-stomach is connected with the cavity of the stem by a circular opening, which is surrounded by a sphincter; and an alternate movement of dilatation and contraction takes-place in it, fluid being apparently forced-up from below, and then expelled again, after which the sphincter closes, in preparation for a recurrence of the operation; this, as observed by Mr. Lister, being repeated at intervals of eighty seconds. Besides the foregoing movement, a regular flow of fluid, carrying with it solid particles of various sizes, may be observed along the whole length of the stem, passing in a somewhat spiral direction, and a good deal resembling the rotation in *Chara* (§ 201).—The Reproductive process in this family seems to be effected in various modes; and the true relation between them has not yet been clearly made-out. The polype-stem sometimes puts-forth branches, at the termination of which new polypes ultimately

* Allman (loc. cit.).

make their appearance, as in other composite Hydrozoa; and in the genus *Eudendrium*, which is found on many parts of our coasts, attached to old shells or stones dredged-up from deep water, a beautiful tree-like structure, from three to six inches high, is thus formed.—But around the polype-heads are evolved gemmæ of a different kind, as in *Coryne*; these being capsules, within which are formed either one or several ovoid bodies, that begin to develop themselves into the polype-form even before their escape from their containing cases, and soon fix themselves after their emersion, shooting-up into stems like those of the parent. Whether this is a method of producing free gemmæ, or whether it is a process of sexual generation, is not yet certainly known; no spermatozoa have been observed in any of these capsules; and if none should be detected by careful search, the polypes thus evolved may be presumed to be buds. In several Tubulariæ, the evolution of free Medusa-like buds, resembling those of *Syncoryne* (Fig. 222), has been observed; and all analogy would indicate that they act as the sexual organs, the development of spermatozoa in some, and of ova in others, probably not taking-place until after they have led an independent life for some time. It is worthy of mention here, that when a Tubularia is kept in confinement, the polype-heads almost always drop-off after a few days, but are soon renewed again by a new growth from the stem beneath; and this exuviation and regeneration may take place many times in the same individual.

30†. It is in the families *Campanulariæ* and *Sertulariæ*, that the horny polypary attains its completest development; since it not only affords an investment to the stem, but forms cups or cells for the protection of the polypes, as well as capsules for that of the reproductive bodies. In the *Campanulariæ*, the polype-cells are campanulate or bell-shaped, and are borne at the extremities of ringed stalks (Fig. 223, *c*); in the *Sertulariæ*, on the other hand, the polype-cells lie along the stem and branches, attached either to one side only, or to both sides (Fig. 22†). In both, the general structure of the individual polypes (Fig. 223, *d*) closely corresponds with that of the Hydra; and the mode in which they obtain their food is essentially the same. Of the products of digestion, however, a portion finds its way down into the tubular stem, for the nourishment of the general fabric; and very much the same kind of circulatory movement can be seen in *Campanularia*, as in *Tubularia*, the circulation being most vigorous in the neighbourhood of growing parts. It is from the soft flesh (*f*)

FIG. 223.

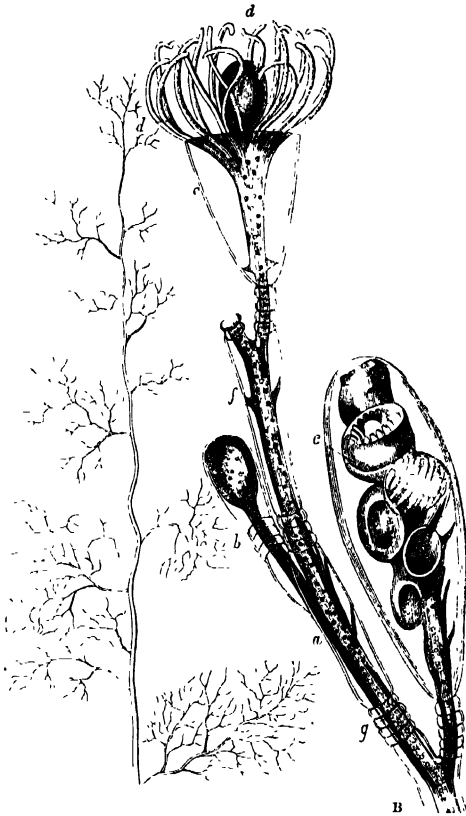

Campanularia gelatinosa.—A, upper part of the stem and branches, of the natural size; B, a small portion enlarged, showing the structure of the animal; *a*, terminal branch bearing polypes; *b*, polype-bud partially developed; *c*, horny cell containing the expanded polype *d*; *e*, ovarian capsule, containing medusiform gemmæ in various stages of development, *f*, fleshy substance extending through the stem and branches, and connecting the different polype-cells and ovarian capsules; *g*, annular constrictions at the base of the branches.

contained in the stem and branches, that new polype-buds (*b*) are evolved; these carry before them (so to speak) a portion of the horny integument, which at first completely invests the bud; but as the latter acquires the organisation of a polype, the case thins-away at its most prominent part, and an opening is formed, through which the young polype protrudes itself. The origin of the bodies commonly but erroneously designated 'ovarian capsules' (*c*), is exactly similar; but their destination is very different. Within them are evolved, by a budding-process, the generative organs of the Zoophyte; and these sometimes develop themselves into the form of independent Medusæ, which completely detach themselves from the stock that bore them, make their way out of the capsule, and swim-forth freely, to mature their sexual products (some developing spermatozoa, and others ova) and give-origin to a new generation of polypes; whilst in other cases, these flower-buds, whose Medusan structure is less distinctly pronounced, do not completely detach themselves, but expand one after another at the mouth of the capsule, withering and dropping-off after they have matured their generative products; and in other cases, again, the Medusan conformation is altogether obscured by want of development, the sexual act being performed by these bodies whilst they are still enclosed within their capsules. There is reason to believe that the male and female Medusoids are always developed within separate capsules, possibly on distinct polypidoms; the males give-forth spermatozoa; whilst the females prepare ova, which, when fertilized by the entrance of spermatozoa, develop themselves into ciliated 'gemmules,' and these, escaping from the capsules, soon evolve themselves into true polypes. This last is the only mode of generation that has been yet witnessed among the *Tubulariæ*; for no free Medusoids have been observed to make their way out of the capsules of any members of this family (Fig. 221), within which may be seen several bodies that are commonly reputed to be eggs, but are really imperfectly-developed gemmæ of the Medusan type. It is worthy of notice, that the horny capsule has been shown by Prof. E. Forbes, to be essentially a metamorphosed branch, whose numerous small cells have coalesced (as it were) into a single large one; this is made obvious by a careful comparison of the forms under which it presents itself, in different members of these two families.

305. There are few parts of our coasts, which will not supply some or other of the beautiful and interesting forms of Zoophytic life which have been thus briefly noticed, without

any more trouble in searching for them, than that of examining the surfaces of rocks, stoucs, sea-weeds, and dead shells between the tide-marks. Many of them habitually live in that situation; and others are frequently cast-up by the waves from the deeper waters, especially after a storm. Many kinds, however, can only be obtained by means of the dredge. For observing them during their living state, no means is so convenient as the zoophyte-trough (§ 69), invented for that express purpose by Mr. Lister, to whom we owe not only many improvements in the Microscope and its appurtenances, but also some of the earliest and best observations upon this class of Zoophytes which the application of the Achromatic principle permitted. Before mounting them for preservation as microscopic objects, the Author has found it best to keep them for some time in strong spirit; after a prolonged maceration in which, they may be mounted in spirit sufficiently dilute to be destitute of any injurious action on the cement. Goadby's fluid also may be used; but the preservation of the soft parts is not quite so complete with it as with spirit. The size of the cell must of course be proportioned to that of the object; and if it be desired to mount such a specimen as may

FIG. 224.

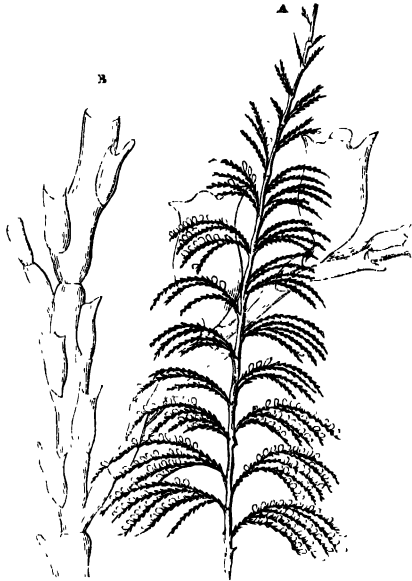

Sertularia cupressina :—A, natural size; B, portion magnified.

serve for a characteristic illustration of the mode of growth of the species it represents, the large shallow cells, whose walls are made by cementing four strips of glass to the plate that forms the bottom (§ 136), will generally be found preferable. The horny polyparies of the Sertulariæ, when mounted in Canada balsam, are beautiful objects for the Polariscopes; but in order to prepare them successfully, some nicety of management is required. The following are the outlines of the method recommended by Dr. Golding Bird, who very successfully practised it. The specimens selected, which should not exceed two inches in length, are first to be submitted, while immersed in water of 120°, to the vacuum of an air-pump. The ebullition which will take place within the cavities, will have the effect of freeing the polyparies from dead polypes and other animal matter; and this cleansing process should be repeated several times. The specimens are then to be dried, by first draining them for a few seconds on bibulous paper, and then by submitting them to the vacuum of an air-pump, within a thick earthenware ointment-pot fitted with a cover, which has been previously heated to about 200°; by this means, the specimens are very quickly and completely dried, the water being evaporated so quickly that the cells and tubes hardly collapse or wrinkle. The specimens are then to be placed in camphine, and again subjected to the exhausting process, for the displacement of the air by that liquid; and when they have been thoroughly saturated, they should be mounted in Canada balsam in the usual mode. When thus prepared, they become very beautiful transparent objects for low magnifying powers; and they present a gorgeous display of colours when examined by polarized light, with the interposition of a plate of selenite. These objects are peculiarly fitted for Mr. Furze's combination of the polarizing plate with the spotted lens (§ 63); as they then exhibit all the richness of coloration which the former develops, with the peculiar solidity or appearance of projection which they derive from the use of the latter.

306. No result of Microscopic research has been more unexpected, than the discovery of the close relationship subsisting between the Hydroid Zoophytes and the Medusoid Acalephæ (or jelly-fish). We have seen that many of the small free-swimming Medusans, belonging to that simple tribe of which *Thaumantias* (Fig. 225) may be taken as a representative, are really to be considered as the detached sexual apparatus of the Zoophytes from which they have been budded-off, endowed

with independent organs of nutrition and locomotion, whereby they become capable of maintaining their own existence and of developing their generative products. The general conformation of these organs will be understood from the accompanying figure. Many of this group are very beautiful objects for Microscopic examination, being small enough to be viewed entire in the zoophyte-trough. There are few parts of the coast on which they may not be found, especially on a calm warm day, by skimming the surface of the sea with a fine muslin net

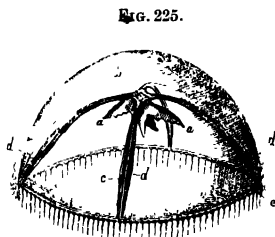

Thamnantius pilosella, one of the 'naked-eyed' Medusæ — *a a*, oral tentacula; *b*, stomach, *c*, gastro-vascular canals, having the ovaries, *d d*, on either side, and terminating in the marginal canal *e e*.

attached to a ring, which may either be fixed to the end of a stick held in the hand, or may be fastened by a string to the stern of the boat as a tow-net. In either case, the net should be taken-up from time to time, held so as to allow the water it contains to drain through it, and then turned inside-out (so that what was previously its internal surface shall now be the external), and moved-about in a bucket of water, so that any minute animals adhering to it may be washed-off.— When we turn from these small and simple forms, to the large and highly-developed Medusans which are commonly known as 'jelly-fish,' we find that their history is essentially similar; for their progeny have been ascertained to develop themselves in the first instance under the polype-form, and to lead a life which in all essential respects is zoophytic; their development into Medusæ taking-place only in the closing phase of their existence, and then rather by gemmation from the original polype, than by a metamorphosis of its own fabric. The embryo emerges from the cavity of its parent, within which the first stages of its development have taken place, in the condition of a ciliated gemmule, of rather oblong form, very closely resembling an Infusory animalcule, but destitute of a mouth. One end soon contracts and attaches itself, however, so as to form a foot; the other enlarges and opens to form a mouth, four tubercles sprouting around it, which grow

into tentacula; whilst the central cells melt-down to form the cavity of the stomach. Thus a Hydra-like polype is formed, which soon acquires many additional tentacula; and this, according to the observations of Sir J. G. Dalyell, leads in every important particular the life of a Hydra, propagates like it by repeated gemmation, so that whole colonies are formed as offsets from a single stock, and can be multiplied like it by artificial division, each segment developing itself into a perfect Hydra. There

FIG. 226.

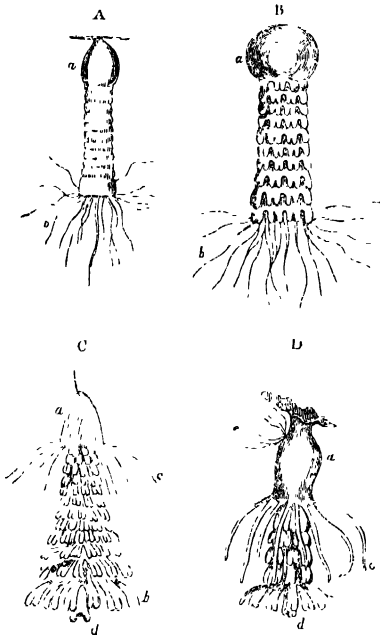

Successive Stages of Development of *Medusa-buds* from *Strobila-tarva*.—*a*, polype-body, *b*, its original circle of tentacula; *c*, its secondary circle of tentacula, *d*, proboscis of most advanced *Medusa-disk*; *e*, polype-bud from side of polype body.

seems to be no definite limit to its continuance in this state, or to its power of giving origin to new polype-buds; but under conditions not yet ascertained, the *Strobila* (as it is termed), ceases to propagate by ordinary gemmation, and enters upon an entirely new series of changes. In the first place, the body becomes more cylindrical in form than it previously was; then a constriction or indentation is seen around it, just below the ring which encircles the mouth and gives origin to the tentacula; and similar constrictions are soon repeated around the lower parts of the cylinder, so as to give

to the whole body somewhat the appearance of a rouleau of coins; a sort of fleshy bulb, somewhat of the form of the original polype, being still left at the attached extremity (Fig. 226, A). The number of circles is indefinite, and all are not formed at once, new constrictions appearing below, after the upper portions have been detached; as many as 30 or even 40 have thus been produced in one specimen. The constrictions then gradually deepen, so as to divide the cylinder into a pile of saucer-like bodies; the division being most complete above, and the upper disks usually presenting some increase in their diameter: and whilst this is taking-place, the edges of the disks become divided into lobes (B), each lobe soon presenting the cleft with the supposed rudimentary eye (more probably an auditory organ) at the bottom of it, which is to be plainly seen in the detached Medusæ (Fig. 227, c). Up to this period, the tentacula of the original polype surmount the highest of the disks; but before the detachment of the topmost disk, this circle disappears, and a new one is developed at the summit of the bulb which remains at the base of the pile (c, c). At last, the topmost and largest disk begins to exhibit a sort of convulsive struggle; it becomes detached and swims freely away; and the same series of changes takes place from above downwards, until the whole pile of disks is detached and converted into free-swimming Medusæ. But the original polyloid body still remains; and may return to its polype-like and original mode of gemmation (D, c), becoming the progenitor of a new colony of Strobilæ, every one of which may in its turn bud-off a pile of Medusa-disks.

307. The bodies thus detached have all the essential characters of the adult *Medusæ*. Each consists of an umbrella-like disk, divided at its edge into a variable number of lobes, usually eight; and of a stomach, which occupies a considerable proportion of the disk, and projects downwards in the form of a proboscis, in the centre of which is the quadrangular mouth (Fig. 227, A, B). As the animal advances towards maturity, the intervals between the segments of the border of the disk gradually fill-up, so that the divisions are obliterated; tubular prolongations of the stomach extend themselves over the disk; and from its borders there sprout-forth tendril-like filaments, which hang-down like a fringe around its margin. From the four angles of the mouth, which, even in the youngest detached animal, admits of being greatly extended and protruded, prolongations are put-forth, which form the four

large tentacula of the adult. And finally the generative organs make their appearance in four chambers disposed

FIG. 227.

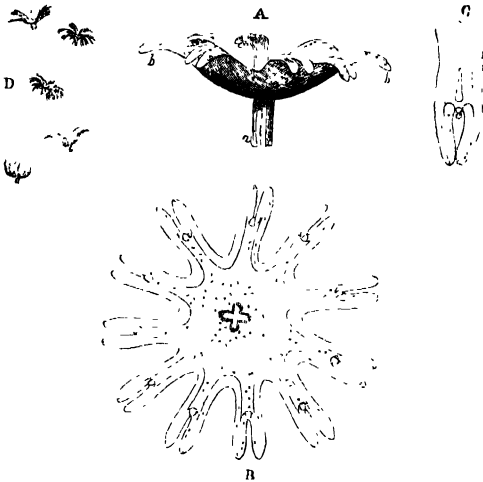

Development of *Medusa* from detached gemmae of *Strobila*.—
 A, individual viewed sideways, and enlarged, showing the proboscis, *a*,
 and *b* the bifid lobes, B, individual seen from above, showing the bifid
 lobes of the margin, and the quadrilateral mouth, C, one of the bifid
 lobes still more enlarged, showing the ocellus (?) at the bottom of the
 cleft, D, group of young *Medusae* as seen swimming in the water, of
 the natural size.

around the stomach; which are occupied by plaited membranous ribands, containing sperm-cells in the male, and ova in the female; and the embryos evolved from the latter, when they have been fertilized by the agency of the former, repeat the extraordinary cycle of phenomena which has been now described.

308. In connection with the preceding, it will be convenient to mention two curious little marine animals of frequent occurrence, the true place of which in the scale it seems difficult to determine, but which, having the free swimming habits and the soft texture of the *Medusae*, have been very commonly ranked as members of the same class. One of

these is the *Cydippe pileus* (Fig. 228, A) very commonly known as the *Beroë*, which designation, however, properly appertains to another animal (B) of the same grade of organisation. The body of *Cydippe* is a nearly-globular mass of soft jelly, usually about 3-8ths of an inch in diameter; and it may be

FIG. 228.

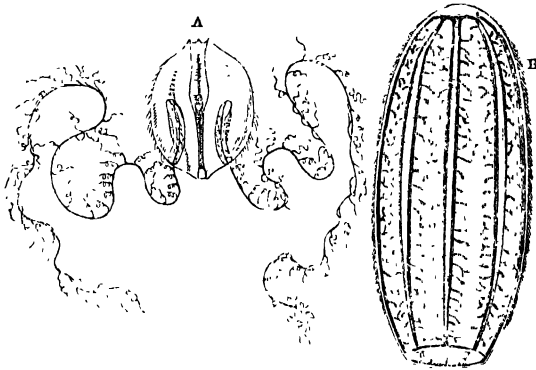

A, *Cydippe pileus* with its tentacles extended.—B, *Beroë Forskalii*, showing the tubular prolongations of the stomach.

observed, even with the naked eye, to be marked by eight bright bands, which proceed from pole to pole like meridian-lines. These bands are seen with the microscope to be formed of rows of large cilia, which are in a state of pretty-constant vibration, though sometimes they are at rest; and if the sunlight should fall upon them when they are in activity, they display very beautiful iridescent colours. The mouth of the animal, situated at one of the poles, leads to a stomachal cavity of cylindrical shape, which extends about as far as the centre of the body, and then narrows into an intestinal tube which terminates at the opposite pole; from this stomach tubular prolongations pass-off beneath the ciliated bands, very much as in the true *Beroë* (B). In addition to the rows of cilia, the *Cydippe* is furnished with a pair of locomotive organs of a very peculiar kind; these are long tendril-like filaments, arising from the bottom of a pair of cavities in the posterior part of the body, and furnished with lateral branches (A);

within these cavities they are often doubled-up, so as not to be visible externally; and when they are ejected, which often happens quite suddenly, the main filaments first come-forth, and the lateral tendrils subsequently uncoil themselves, to be drawn-in again and packed-up within the cavities, with almost equal suddenness. The liveliness of this little creature, which may sometimes be collected in large quantities at once by the muslin net, renders it a most beautiful subject for observation when due scope is given to its movements; but for the sake of microscopic examination, it is of course necessary to confine these. Various species of true *Beroë*, some of them even attaining the size of a small lemon, are occasionally to be met-with on our coasts; in all of which the movements of the body are effected by the like agency of cilia, arranged in meridional bands.—Very different, however, is the structure of another little globular jelly-like animal, the *Noctiluca miliaris* (Fig. 229), to which the diffused luminosity of the sea, a beautiful phenomenon that is of very frequent occurrence on our shores, is chiefly attributable. This animal is just large enough to be discerned by the naked eye, when the water in which it may

FIG. 229.

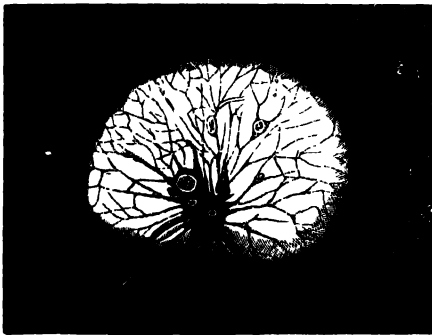
*Noctiluca miliaris.*

be swimming is contained in a glass jar exposed to the light; and a tail-like appendage, marked with transverse rings, which is employed by the animal as an instrument of locomotion, both for swimming and for pushing, may also be observed with a hand-glass. Near the point of its implantation in the body, is a definite mouth, on one side of which a projecting tooth

has been seen by Mr. Huxley; and this mouth leads through a sort of œsophagus, into a large irregular cavity, apparently channelled-out in the jelly-like substance of the body, and therefore considered by some in the light of a mere 'vacuole,' though by Mr. Huxley it is considered to possess regular walls; whilst from its cavity there passes-forth a prolongation, which leads, in his belief, to a distinct anal orifice.* The external coat is denser than the contained sarcode; and the former sends thread-like prolongations through the latter, so as to divide the entire body into irregular chambers, in some of which 'vacuoles' are frequently to be seen. Very little is known about the reproduction of this animal; and until the mode in which it performs that important function shall have been made-out, and it shall have also been determined whether it passes through any other phase of existence, we are scarcely in a position to speak positively of its true affinities. The nature of its luminosity is found by microscopic examination to be very peculiar; for what appears to the eye to be a uniform glow, is resolvable under a sufficient magnifying power into a multitude of evanescent scintillations; and these are given-forth with increased intensity, whenever the body of the animal receives any mechanical shock, such as that produced by shaking the vessel or pouring-out its contents, or is acted-on by various chemical stimuli, such as dilute acids, which, however, speedily exhaust the light-producing power, occasioning disorganisation of the body.

30^a *Anthozoa*.—This group, which constitutes the second great division of the class of Zoophytes, includes all those larger forms, whose polypes, when expanded, present the likeness of 'animal flowers;' and it consists of two principal subdivisions,—the *Asteroida*, or Alcyonian zoophytes, whose polypes, having only six or eight broad short tentacula, present a star-like aspect when expanded,—and the *Helianthoida*, whose polypes, having numerous tentacula disposed in several rows, bear a resemblance to sun-flowers or other composite blossoms. Of the first of these orders, which contains no solitary species, a characteristic example is found in the *Alcyonium digitatum* of our coasts, which is commonly known under the name of 'dead-man's toes,' or 'sea-paps.' When a specimen of this is first torn from the rock to which it has attached itself, it contracts into an unshapely mass, whose surface presents nothing but a series of slight depressions arranged with a certain regularity. But after

* "Quart. Journ. of Microsc. Sci.," vol. iii. p. 49; see also pp. 102, 199.

being immersed for a little time in a jar of sea-water, the mass swells-out again, and from every one of these depressions

FIG. 230.

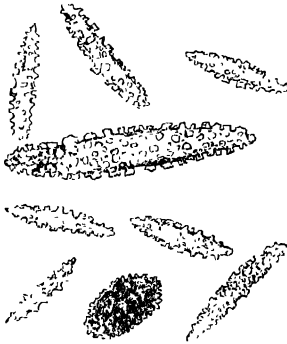
Spicules of *Alcyonium* and *Gorgonia*.

an eight-armed polype is protruded, "which resembles a flower of exquisite beauty and perfect symmetry. In specimens recently taken, each of the petal-like tentacula is seen with a hand-glass to be furnished with a row of delicately-slender *pinnæ* or filaments, fringing each margin, and arching outwards; and with a higher power, these *pinnæ* are seen to be roughened, throughout their whole length, with numerous prickly rings. After a day's captivity, however, the petals shrink-up into short, thick, unshapely masses, rudely notched at their edges" (Gosse). When a mass of this sort is cut-into, it is found

FIG. 231.

FIG. 231. Spicules of *Gorgonia guttata*.
FIG. 232. Spicules of *Muricea elongata*.

FIG. 232.



to be channelled-out, somewhat like a sponge, by ramifying canals; the vents of which open into the stomachal cavities of the polypes, which are thus brought into free communication with each other,—a character that especially distinguishes this order. A movement of fluid is kept-up within these canals, as may be distinctly seen through their transparent bodies, by means of cilia lining the internal surfaces of the polypes ;

but no cilia can be discerned on their external surfaces. The tissue of this spongy polypidom is strengthened throughout, like that of Sponges (§ 296), with mineral spicules (always, however, calcareous), which are remarkable for the elegance of their forms; these are disposed with great regularity around the bases of the polypes, and even extend part of their length upwards on their bodies. The presence of such spicules is, in fact, a very constant character throughout this group. Thus in the *Gorgonia* or Sea-fan, whilst the central part of the polypidom is consolidated into a horny axis, the soft flesh which clothes this axis is so full of tuberculated spicules, especially in its outer layer, that, when this dries-up, the spicules form a thick yellowish or reddish incrustation upon the horny stem; this is, however, so friable, that it may be easily rubbed-down between the fingers, and, when examined with the Microscope, it is found to consist of spicules of different shapes and sizes, more or less resembling those shown in Figs. 230-232, sometimes colourless, but sometimes of a beautiful crimson, yellow, or purple. These spicules are best seen by the methods of illumination that give a black ground, on which they stand out with great brilliancy. They are, of course, to be separated from the animal substance in the same manner as the calcareous spicules of Sponges (§ 298); and they should be mounted, like them, in Canada balsam.—It is interesting to remark that the hard calcareous stem of the *Red Coral*, which takes the place of the horny axis of the Sea-fan, is found, by the examination of very thin sections, to be made-up of a solid aggregation of separate spicules, closely resembling those of Alcyonian zoophytes in general. The spicules always possess an organic basis; as is proved by the fact, that when their lime is dissolved by dilute acid, a gelatinous-looking residuum is left, which preserves the form of the spicule, and is probably to be considered as a cell in an early stage of formation, its wall not yet being differentiated as a distinct membranc.

310. Of the order *Helianthoida*, the common *Actinia* or 'Sea-Anemone' may be taken as the type; the individual polypes of all the composite structures included in the group being constructed upon the same model. In by far the larger proportion of these Zoophytes, the bases of the polypes, as well as the soft flesh that connects-together the members of aggregate masses, are consolidated by calcareous deposit into stony corals; and the surfaces of these are beset with cells, usually of a nearly-circular form, each having numerous lamellæ

radiating from its centre towards its circumference, which are formed by the consolidation of the lower portions of the radiating partitions, that divide the space intervening between the stomach and the general integument of the animal into separate chambers. This arrangement is seen on a large scale in the *Fungia* or 'mushroom coral' of tropical seas, which is the stony base of a solitary anemone-like polype; on a far smaller scale, it is seen in the little *Caryophyllia*, a like solitary polype of our own coasts, which is scarcely distinguishable from an *Actinia* by any other character than the presence of this disk, and also on the surface of many of those stony corals known as 'Madreporcs;' whilst in some of these the individual polype-cells are so small, that the lamellated arrangement can only be made-out when they are considerably magnified. Portions of the surface of such corals, or sections taken at a small depth, are very beautiful objects for the lower powers of the Compound Microscope, the former being viewed by reflected and the latter by transmitted light. And thin sections of various fossil Corals of this group are very striking objects for the lower powers of the Oxyhydrogen Microscope.—The chief point of interest to the Microscopist, however, in the structure of these animals, lies in the extraordinary abundance and high development of those 'filiferous capsules,' or 'thread-cells,' the presence of which on the tentacles of the Hydraform polypes has been already noticed (§ 300), and which are also to be found, sometimes sparingly, sometimes very abundantly, in the tentacles surrounding the mouth of the Medusæ, as well as on other parts of their bodies. If a tentacle of any of the Sea-Anemonies, so abundant on our coasts (the smaller and more transparent kinds being selected in preference), be cut-off, and be subjected to gentle pressure between the two glasses of the aquatic-box or of the compressorium, multitudes of little dart-like organs will be seen to project themselves from its surface near its tip; and if the pressure be gradually augmented, many additional darts will every moment come into view. Not only do these organs present different forms in different species; but even in one and the same individual very strongly-marked diversities are shown, of which a few examples are given in Fig. 233. At A, B, C, and D, is shown the appearance of the 'filiferous capsules,' whilst as yet the thread lies coiled-up in their interior; whilst at E, F, G, H are seen a few of the most striking forms which they exhibit, when the thread or dart has started-forth. The most probable account of their

organisation seems to be, that each is a cell, of which one end is extended into the thread-like or dart-like prolongation, but which is doubled-in upon itself, in such a manner that the armature appears to be contained in its interior; and that the springing-out of the dart is due to the eversion of the portion of the cell which had previously been pressed-inwards. These thread-cells are found, however, not merely in the tentacles and other parts of the external integument of Helianthoid Zoophytes, but also in the long filaments which lie in coils within the chambers that surround the stomach, in contact with the sexual organs which are attached to the lamellæ dividing the chambers. It was formerly supposed that the last-named organs were always ovaria, and that the long and slender filaments contain sperm-cells and are consequently the male organs. But since it has been proved that

FIG. 233.

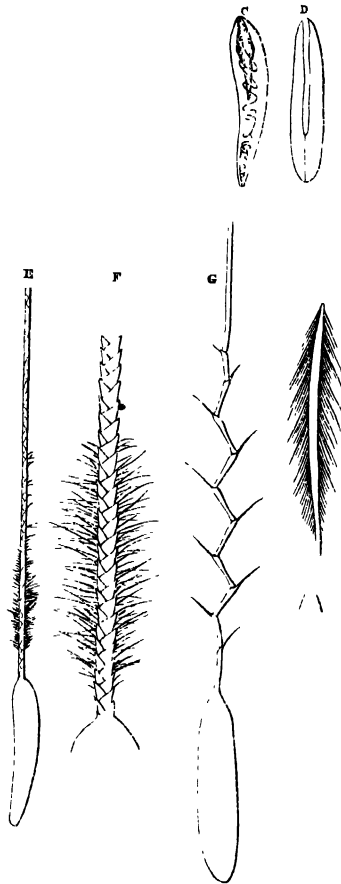

Filiferous Capsules of Helianthoid Polypes:—A, B, *Corynactis Allmanni*; C, E, F, *Caryophyllia Smithii*; D, G, *Actinia crassicornis*; H, *Actinia candida*.

the peculiar 'filiferous capsules' which lie side by side in these filaments are really identical in structure with those which are found in the skin, the idea of their sexual nature has been abandoned; and a more careful examination of the organs attached to the walls of the chambers has shown, that these are not always ovaries, but that they sometimes contain sperm-cells, the two sexes being here divided, not united in the same individual. What can be the office of the filiferous filaments thus contained in the interior of the body, it is difficult to guess-at. They are often found to protrude from rents in the external tegument, when any violence has been used in detaching the animal from its base; and when there is no external rupture, they are often forced through the wall of the stomach into its cavity, and may be seen hanging-out of the mouth. The largest of these capsules, in their unprojected state, are about 1-300th of an inch in length: and the thread or dart, in *Corynactis Allmanni*, when fully extended, is not less than 1-8th of an inch, or thirty-seven times the length of the capsule.*

* For the fullest description of these curious bodies, as well as for much other valuable information upon Zoophytes, see Mr. Gosse's "Naturalist's Rambles on the Devonshire Coast."—Those who may desire to acquire a more systematic and detailed acquaintance with this group, may be especially referred to the following Treatises and Memoirs:—Dr. Johnston's "History of British Zoophytes," Prof. Owen's "Lectures on the Comparative Anatomy and Physiology of the Invertebrate Animals," Prof. Rymer Jones's "General Outline of the Organisation of the Animal Kingdom," Prof. Milne-Edwards's "Recherches sur les Polypes," Prof. Van Beneden 'Sur les Tubulaires,' and 'Sur les Campanulaires,' in "Mem. de l'Acad. Roy. de Bruxelles," tom. xvii., Sir J. G. Dalyell's "Rare and Remarkable Animals of Scotland," vol. i., Trembley's "Mem. pour servir à l'histoire d'un genre de Polype d'Eau douce," M. Hollard's 'Monographie du Genre *Actina*,' in "Ann. des Sci. Nat.," Sér. 3, tom. xv., M. Mummery, 'On the development of *Tubularia indivisa*,' in "Transact. of Microsc. Soc.," 2nd Ser., vol. i. p. 28, and Prof. Max. Schultze, 'On the Male Reproductive Organs of *Campanularia geniculata*,' in "Quart. Journ. of Microsc. Sci.," vol. iii. p. 59.

CHAPTER XII.

OF ECHINODERMATA.

311. As we ascend the scale of Animal life, we meet with such a rapid advance in complexity of structure, that it is no longer possible to acquaint one's-self with any organism by microscopic examination of it as a whole; and the dissection or analysis which becomes necessary, in order that each separate part may be studied in detail, belongs rather to the Comparative Anatomist than to the ordinary Microscopist. This is especially the case with the *Echinus* (sea-urchin), *Asterias* (star-fish), and other members of the class Echinodermata; since even a general account of their complex organisation would be quite foreign to the purpose of this work; whilst there are certain parts of their structure, which furnish microscopic objects of such beauty and interest that they cannot by any means be passed-by; besides which, recent observations on their embryonic forms have revealed a most unexpected order of facts, the extension and verification of which will be of the greatest service to science,—a service that can only be effectually rendered by well-directed Microscopic research in fitting localities.

312. It is in the structure of that calcareous skeleton, which probably exists, under some form or other, in every member of this class, that the Microscopist finds most to interest him. This attains its highest development in the *Echinida*; in which it forms a box-like shell, or 'test,' composed of numerous polygonal plates jointed to each other with great exactness, and beset on its external surface with 'spines,' which may have the form of prickles of no great length, or may be stout-club-shaped-bodies, or, again, may be very long and slender rods. The intimate structure of the shell is everywhere the same; for it is composed of a *network*, which consists of carbonate of lime with a very small quantity of animal matter as a basis, and which extends in every direction (*i. e.* in thickness, as well as in length and breadth), its *areolæ* or interspaces freely communicating with each other (Fig. 234). These

'arcolæ,' and the solid structure which surrounds them, may bear an extremely variable proportion, one to the other; so

FIG. 234.

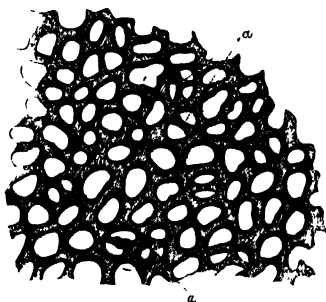

Section of Shell of *Echinus*, showing the calcareous network of which it is composed:—*a a*, portions of a deeper layer.

pendicular to their plane, are so arranged that the perforations in one shall correspond to the intermediate solid structure in the next; and their transparency is such, that

FIG. 235.

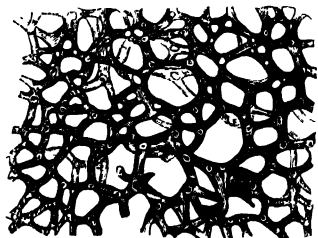

Transverse Section of medullary portion of Spine of *Acrocladia*, showing its more open network.

if a portion of a fractured edge, or any other part from which the investing membrane has been removed, be laid upon fluid of almost any description, this will be rapidly sucked-up into

that in two masses of equal size, the one or the other may greatly predominate; and the texture may have either a remarkable lightness and porosity, if the network be a very open one, like that of Fig. 235, or may possess a considerable degree of compactness if the solid portion be strengthened. Generally speaking, the different layers of this network, which are connected together by pillars that pass from one to the other in a direction perpendicular to their plane, are so arranged that the perforations in one shall correspond to the intermediate solid structure in the next; and their transparency is such, that when we are examining a section thin enough to contain only two or three such layers, it is easy, by properly 'focussing' the Microscope, to bring either one of them into distinct view. From this very simple but very beautiful arrangement, it comes to pass that the plates of which the entire 'test' is made-up, possess a very considerable degree of strength, notwithstanding that their porosity is such, that

its substance. A very beautiful example of the same kind of calcareous skeleton, having a more regular conformation, is furnished by the disk or rosette which is contained in the tip of every one of the tubular suckers put-forth by the living Echinus from the ambulacral pores of its shell. If the entire disk be cut-off, and be mounted when dry in Canada balsam, the calcareous rosette may be seen sufficiently well; but its beautiful structure is better made-out, when the animal membrane that encloses it has been got-rid-of by boiling in caustic potass; and the appearance of one of the five segments of which it is composed, when thus prepared, is shown in Fig. 236.

FIG. 236.

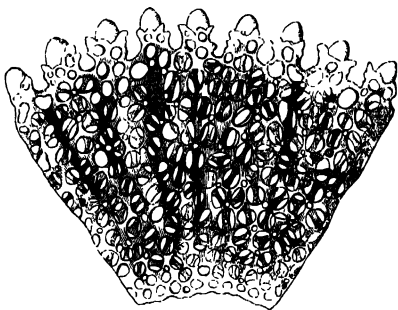

One of the segments of the calcareous skeleton of an Ambulacral disk of *Echinus*.

313. The most beautiful display of this reticulated structure, however, is shown in the structure of the 'spines' of *Echinus*, *Cidaris*, &c.; in which it is combined with solid ribs or pillars, disposed in such a manner as to increase the strength of these organs; a regular and elaborate pattern being formed by their intermixture, which shows considerable variety in different species.—When we make a thin transverse section of almost any spine belonging to the genus *Echinus* (the small spines of our British species, however, being exceptional in this respect), we are at once made aware of the existence of a number of concentric layers, arranged in a manner that strongly reminds us of the concentric rings of an Exogenous tree (Fig. 167). The number of these layers is extremely variable; depending not merely upon the age of the spine, but

(as will presently appear) upon the part of its length from which the section happens to be taken. The centre is usually occupied by a very open network (Fig. 235); and this is bounded by a row of transparent spaces (like those at *a a'*, *b b'*, *c c'*, Fig. 237), which, on a cursory inspection, might be supposed to be void spaces, but which on a closer examination are found to be the sections of solid ribs or pillars, which run in the direction of the length of the spine, and form the exterior of every layer. Their solidity becomes very obvious, when we either examine a section of a spine whose substance is pervaded (as often happens) with a colouring matter of some depth, or when we look at a very thin section by the 'black-ground' illumination. Around the innermost circle of these solid pillars, there is another layer of the calcareous network, which again is surrounded by another circle of solid pillars; and this arrangement may be repeated many times, as shown in Fig. 237, the outermost row of pillars forming the projecting ribs that are very commonly to be distinguished on the surface

FIG. 237.

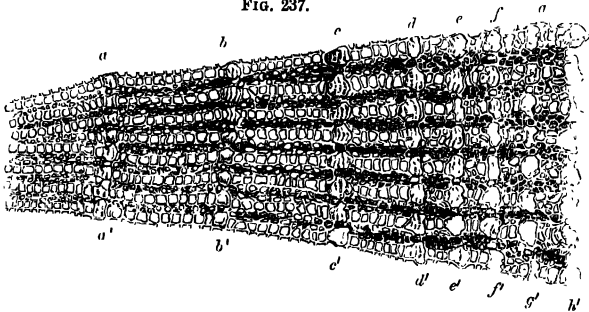
Portion of transverse section of Spine of *Acrocladia mammillata*.

of the spine. Around the cup-shaped base of the spine is a membrane which is continuous with that covering the surface of the shell, and which serves not merely to hold-down the cup upon the tubercle over which it works, but also, by its contractility, to move the spine in any required direction. This membrane is probably continued onwards over the whole surface of the spine, although it cannot be clearly traced to any distance from the base; and the new formations may be presumed to take-place in its substance. Each new forma-

tion completely ensheaths the old; not merely surrounding the part previously formed, but also projecting considerably beyond it; and thus it happens that the number of layers shown in a transverse section, will depend in part upon the place of the section. For if it cross near the base, it will traverse every one of the successive layers from the very commencement; whilst, if it cross near the apex, it will traverse only the single layer of the last growth, notwithstanding that, in the club-shaped spines, this terminal portion may be of considerably larger diameter than the basal; and in any intermediate part of the spine, so many layers will be traversed as have been formed since the spine first attained that length. The basal portion of the spine is enveloped in a reticulation of a very close texture, without concentric layers; forming the cup or socket which works over the tubercle of the shell.—The combination of elegance of pattern with richness of colouring, renders well-prepared specimens of these spines among the most beautiful objects that the Microscopist can anywhere meet-with. The large spines of the various species of the genus *Acrocladia* furnish sections most remarkable for size and elaborateness as well as for depth of colour (in which last point, however, the deep purple spines of *Echinus lividus* are pre-eminent); but for exquisite neatness of pattern, there are no spines that can approach those of *Echinometra heteropora* and *E. lucunter*. The spines of *Heliocidaris variolaris* are also remarkable for their beauty.—No succession of concentric layers is seen in the spines of the British Echini, probably because (according to the opinion of the late Sir J. G. Dalzell) these spines are cast-off and renewed every year; each new formation thus going to make an entire spine, instead of making an addition to that previously existing.—Most curious indications are sometimes afforded by sections of Echinus-spines, of an extraordinary power of reparation inherent in these bodies. For irregularities are often seen in the transverse sections, which can be accounted-for in no other way, than by supposing the spines to have received an injury when the irregular part was at the exterior, and to have had its loss of substance supplied by the growth of new tissue, over which the subsequent layers have been formed as usual. And sometimes a peculiar ring may be seen upon the surface of a spine, which indicates the place of a complete fracture, all beyond it being a new growth, whose unconfornableness to the older or basal portion is clearly shown by a longitudinal section.

314. The spines of *Cidaris* present a marked departure from the plan of structure exhibited in *Echinus*; for not only are they destitute of concentric layers, but the calcareous network which forms their principal substance, is ensheathed in a solid calcareous cylinder perforated with tubules, which seems to take the place of the separate pillars of the *Echini*. This is usually found to close-in the spine at its tip also; and thus it would appear that the entire spine must be formed at once, since no addition could be made either to its length or to its diameter, save on the outside of this sheath, where it is never to be found. The sheath itself often rises-up in prominent points or ridges on the surface of these spines; thus giving them a character by which they may be distinguished from those of *Echini*.—The slender, almost filamentary spines of *Spatangus* (Fig. 238), and the innumerable minute hair-like processes attached to the shell of *Clypeaster*, are com-

FIG. 238.

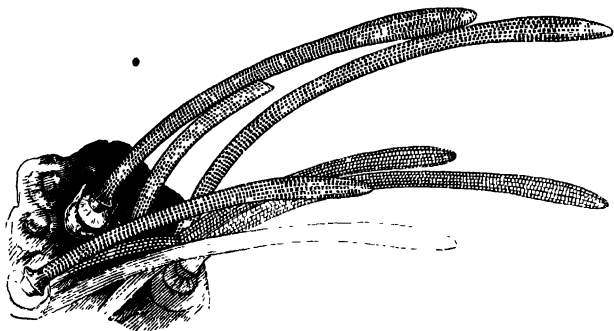
Spines of *Spatangus*.

posed of the like regularly-reticulated substance; and many of these are very beautiful objects for the lower powers of the Microscope, when examined by reflected light, and laid upon a black ground, without any further preparation.—It is interesting also to find that the same structure presents itself in the curious *Pedicellariæ* (forceps-like bodies mounted on long stalks), which are found on the surface of many *Echinida*, and the nature of which has been a source of much perplexity

to Naturalists, some maintaining that they are parasites, whilst others consider them as proper appendages of the Echinus itself. The complete conformity which exists between the structure of their skeleton and that of the animal to which they are attached, would seem to remove all reasonable doubt of their being truly appendages to it, as observation of their actions in the living state would indicate.—Another example of the same structure is found in the peculiar system of plates which surrounds the interior of the oral orifice of the shell, and which gives support to the five teeth that may often be seen projecting externally through that orifice; the whole forming what is known as the ‘lantern of Aristotle’ The texture of the plates or jaws resembles that of the shell in every respect, save that the network is more open; but that of the teeth is much more compact. The latter have been described by Mr. Quekett as consisting of a substance not altogether unlike the ‘dentine’ of the teeth of higher animals, save that the tubuli, though sometimes parallel, usually have more of a reticulated arrangement, and sometimes dilate into irregular ‘lacunæ’ or spaces excavated in the hard substance.* The Author is not prepared to speak with confidence on this point; but he is disposed to think that the structure of the teeth is essentially the same as that of the shell, save in the interspaces of the network being much narrower; and that the appearance of tubuli (in which Mr. Quekett has not been able to make-out distinct walls) is due merely to the elongation of these interspaces.

315. The calcareous plates which form the less compact skeletons of the *Asteriada* (star-fish and their allies) and of the *Ophiurida* (sand-stars and brittle-stars), have the same texture as those of the shell of Echinus. And this presents it-

self, too, in the spines or prickles of their surface, when these (as in the large *Goniaster equestris*) are large enough to be furnished with a calcareous framework,

FIG. 239.



Calcareous plate and claw of *Astrophyton* (Euryale).

* "Lectures on Histology," vol. ii., p. 234.

and are not mere projections of the horny integument. An example of this kind, furnished by the *Astrophyton* (better known as the *Euryale*), is represented in Fig. 239. The spines with which the arms of the species of *Ophiocoma* (brittle-star) are beset, are often remarkable for their beauty of conformation; that of *O. rosula*, one of the most common kinds, might serve (as Prof. E. Forbes justly remarked) in point of lightness and beauty, as a model for the spire of a cathedral.

316. The calcareous skeleton is very highly developed in the *Crinoidea*; their stems and branches being made-up of a calcareous network, closely resembling that of the shell of the *Echinus*. This is extremely well seen, not only in the recent *Pentacrinus Caput Medusæ*, a somewhat rare animal of the West Indian seas, but also in a large proportion of the fossil *Crinoidea*, whose remains are so abundant in many of the older geological formations; for notwithstanding that these bodies have been penetrated in the act of fossilization by a mineral infiltration, which seems to have substituted itself for the original fabric (a regularly-crystalline cleavage being commonly found to exist in the fossil stems of *Encrinites*, &c., as in the fossil spines of *Echinidans*), yet their organic structure is often most perfectly preserved. In the circular stems of *Encrinites*, the texture of the calcareous network is uniform, or nearly so, throughout; but in the pentangular *Pentacrinini*, a certain figure or pattern is formed by variations of texture in different parts of the transverse section; and the patterns, though formed upon one general plan, are sufficiently diverse in different species, to enable these to be recognized by the examination of a transverse section of a single joint of the stem.

317. The structure of the shells, spines, and other solid parts of the skeleton of *Echinodermata* can only be displayed by thin sections, made upon the general plan already described (§§ 109, 110). But their peculiar texture requires that certain precautions should be taken; in the first place, in order to prevent the section from breaking, whilst being reduced to the desirable thinness; and in the second, to prevent the interspaces of the network from being clogged by the particles abraded in the reducing-process.—A section of the shell, spine, or other portion of the skeleton, should first be cut with a fine saw, and be rubbed on a flat file until it is about as thin as an ordinary card, after which it should be smoothed on one side by friction with water on a Water-of-Ayr

stone. It should then be carefully dried, first on white blotting-paper, afterwards by exposure for some time to a gentle heat, so that no water may be retained in the interstices of the network, which would oppose the complete penetration of the balsam. Next, it is to be attached to a glass-slip by balsam hardened in the usual manner; but particular care should be taken, first, that the balsam be brought to exactly the right degree of hardness, and second, that there be enough, not merely to attach the specimen to the glass, but also to saturate its substance throughout. The right degree of hardness is that at which the cement can be with difficulty indented by the thumb-nail; if it be made harder than this, it is apt to chip-off the glass in grinding, so that the specimen also breaks-away; and if it be softer, it holds the abraded particles, so that the openings of the network become clogged with them. If, when rubbed-down nearly to the required thinness, the section appears to be uniform and satisfactory throughout, the reduction may be completed without displacing it; but if (as often happens) some inequality in thickness should be observable, or some minute air-bubbles should present themselves between the glass and the under surface, it is desirable to loosen the specimen by the application of just enough heat to melt the balsam (special care being taken to avoid the production of fresh air-bubbles), and to turn it over so as to attach the side last-polished to the glass, taking care to remove or to break with the needle-point any air-bubbles that there may be in the balsam covering the part of the glass on which it is laid. The surface now brought uppermost is then to be very carefully ground-down; special care being taken to keep its thickness uniform through every part (which may be even better judged-of by the touch, than by the eye), and to carry the reducing process far enough, without carrying it too far. Until practice shall have enabled the operator to judge of this by passing his finger over the specimen, he must have continual recourse to the microscope during the later stages of his work; and he should bear constantly in mind, that, as the specimen will become much more transparent when mounted in balsam and covered with glass, than it is when the ground surface is exposed, he need not carry his reducing process so far as to produce at once the entire transparency he aims-at, the attempt to accomplish which would involve the risk of the destruction of the specimen. In 'mounting' the specimen, liquid balsam should be employed, and only a very gentle heat (not sufficient to

produce air-bubbles, or to loosen the specimen from the glass) should be applied; and if, after it has been mounted, the section should be found too thick, it will be easy to remove the glass cover, and to reduce it further, care being taken to harden the balsam which has been newly laid-on, to the proper degree.

318. If a number of sections are to be prepared at once (and it is often useful to do this for the sake of economy of time, or in order to compare sections taken from different parts of the same spine), this may be most readily accomplished by laying them down, when cut-off by the saw, without any preliminary preparation save the blowing the calcareous dust from their surfaces, upon a thick slip of glass well covered with hardened balsam; a large proportion of its surface may thus be occupied by the sections attached to it, the chief precaution required being that all the sections come into equally close contact with it. Their surfaces may then be brought to an exact level, by rubbing them down, first upon a flat piece of grit (which is very suitable for the rough grinding of such sections), and then upon a large Water-of-Ayr stone whose surface is 'true.' When this level has been attained, the ground surface is to be well washed and dried, and some balsam previously hardened is to be spread over it, so as to be sucked-in by the sections, a moderate heat being at the same time applied to the glass slide; and this being increased to a sufficient degree to loosen the sections without overheating the balsam, the sections are to be turned-over one by one, so that the ground surfaces are now to be attached to the glass slip, special care being taken to press them all into close contact with it. They are then to be very carefully rubbed down, until they are nearly reduced to the required thinness; and if, on examining them from time to time, their thinness should be found to be uniform throughout, the reduction of the entire set may be completed at once; and when it has been carried sufficiently far, the sections, loosened by warmth, are to be taken-up upon a camel-hair brush dipped in turpentine, and transferred to separate slips of glass whercon some liquid balsam has been previously laid, in which they are to be mounted in the usual manner. It more frequently happens, however, that, notwithstanding every care, the sections, when ground in a number together, are not of uniform thickness, owing to some of them being underlaid by a thicker stratum of balsam than others are; and it is then necessary to transfer them to separate slips, before the reducing process is com-

pleted, attaching them with hardened balsam, and finishing each section separately.

319. It now remains for us to notice the curious and often very beautiful structures, which represent, in the order *Holothurida*, the solid calcareous skeleton of the orders already noticed. All the animals belonging to this order are distinguished by the flexibility and absence of firmness of their envelopes; and excepting in the case of certain species which have a set of calcareous plates, supporting teeth, disposed around the mouth, very much as in the *Echinida*, we do not find among them any representation that is apparent to the unassisted eye, of that skeleton which constitutes so distinctive a feature of the class generally. But a microscopic examination of their integument at once brings to view the existence of great numbers of minute isolated plates, every one of them presenting the characteristic reticulated structure, which are set with greater or less closeness in the substance of the skin. Various forms of the plates which thus present themselves in *Holothuria* are shown in Fig. 240; and at *A* is seen an oblique

FIG. 240.



Calcareous plates in skin of *Holothuria*.

view of the kind marked *a*, more highly magnified, showing the very peculiar manner wherein one part is superposed on the other, which is not at all brought into view when it is merely seen through in the ordinary manner.—In the *Synapta*, one of the long-bodied forms of this order, which does not occur upon our own coasts, but is abundant in the Adriatic Sea, the calcareous plates of the integument have the regular form shown at *A*, Fig. 241; and each of these carries the curious anchor-like appendage, *c*, which is articulated to it by

the notched piece at the foot, in the manner shown (in side view) at B. The anchor-like appendages project from the

FIG. 241.

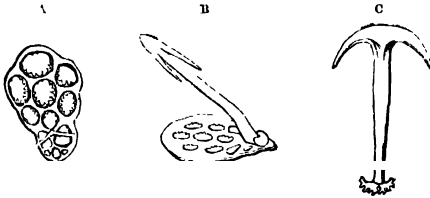

Calcareous skeleton of *Synapta*:—A, plate imbedded in skin; B, the same, with its anchor-like spine attached; C, anchor-like spine separated.

surface of the skin, and may be considered as representing the spines of Echinida. Nearly-allied to the *Synapta* is the *Chirodota*, of which one species (the *C. digitata*), although previously accounted a very rare inhabitant of our seas, has lately been found in considerable numbers at Torquay (by Mr. Kingsley), and might probably be met-with more frequently if carefully searched-for. Not having had the opportunity of examining a specimen of this animal, the Author is unable to say whether or not its integument possesses the very remarkable wheel-like plates, represented in Fig. 242, which are

FIG. 242.

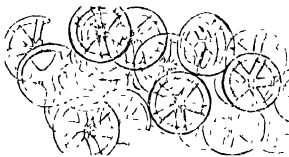

Wheel-like plates from skin of *Chirodota violacea*.

found in the skin of *Chirodota violacea*, a species inhabiting the Mediterranean. These plates are objects of singular beauty and delicacy, being especially remarkable for the very minute notching (scarcely to be discerned in the figures without the aid of a magnifying-glass)

which is traceable round the inner margin of their 'fines.'—There can be scarcely any reasonable doubt, that every member of this order has some kind of calcareous skeleton, disposed in a manner conformable to the examples now cited; and it

would be very valuable to determine how far the very marked peculiarities by which they are respectively distinguished, are characteristic of genera and species. The plates may be obtained separately, by the usual method of treating the skin with a solution of potass; and they should be mounted in Canada balsam. But their position in the skin can only be ascertained, by making sections of the integument, both vertical and parallel to its surface; and these sections, when dry, are most advantageously mounted in the same medium, by which their transparency is greatly increased. All the objects of this class are most beautifully displayed by the black-ground illumination (§§ 61, 62); and the same method, when applied to *very thin* sections of Echinus-spines, brings out some effects of marvellous beauty.

320. *Echinoderm-Larvæ*.—We have now to notice that most remarkable set of objects, furnished to the Microscopic enquirer by the larval forms of this class, for our present knowledge of which, imperfect as it still is, we are almost entirely indebted to the pains-taking and widely-extended investigations of Prof. Muller. All that our limits permit, is a notice of two of the most curious forms of these larvæ, by way of sample of the wonderful phenomena which his researches have brought to light; so as (it may be hoped) to excite such an interest among those Microscopists in particular who may have the opportunity of pursuing these enquiries, as may induce them to apply themselves perseveringly to them, and thus to supply the numerous links which are at present wanting in the chain of developmental history.—The peculiar feature by which the early history of the Echinoderms generally seems to be distinguished, is this,—that the embryonic mass of cells is converted, not into a larva which subsequently attains the adult form by a process of metamorphosis, but into a peculiar *zooid*, which seems to exist for no other purpose than to give origin to the Echinoderm by a kind of internal gemination, and to carry it to a distance by its active locomotive powers, so as to prevent the spots inhabited by the respective species from being overcrowded by the accumulation of their progeny. The larval zooids are formed upon a type quite different from that which characterizes the adults; for instead of a *radial* symmetry, they exhibit a *bilateral*, the two sides being precisely alike, and each having a ciliated fringe along the greater part or the whole of its length. The two fringes are united by a superior and an inferior transverse ciliated band; and between the

two, the mouth of the zooid is always situated. Further, although the adult Star-fish and Sand-stars have neither intestinal tube nor anal orifice, their larval zooids, like those of other Echinoderms, always possess both. The external forms of these larvæ, however, vary in a most remarkable degree, owing to the unequal evolution of their different parts; and there is also a considerable diversity in the several orders, as to the proportion of the fabric of the larva which enters into the composition of the adult form. In the fully-developed Star-fish and Sea-urchin, the only part retained is a portion of the stomach and intestine, which is pinched-off, so to speak, from that of the Larval zooid.

FIG. 243.

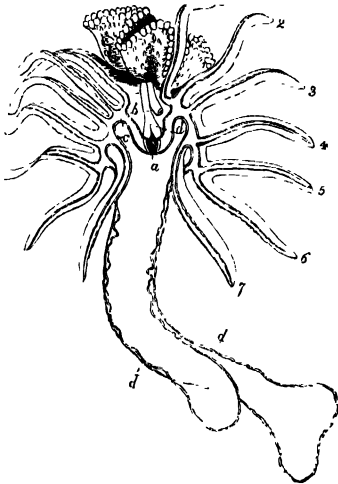

Bipinnaria asterigera, or Larva of Star-fish
 —*a*, mouth; *a'*, œsophagus; *b*, intestinal
 tube and anal orifice; *c*, furrow in which the
 mouth is situated; *d* *d'*, bilobed peduncle;
 1, 2, 3, 4, 5, 6, 7, ciliated arms.

321. One of the most remarkable forms of Echinoderm-larvæ is that which has received the name of *Bipinnaria* (Fig. 243), from the symmetrical arrangement of its natatory organs. The mouth (*a*), which opens in the middle of a transverse furrow, leads through an œsophagus *b'* to a large stomach, around which the body of a Star-fish is developing itself; and on one side of this mouth is observed the intestinal tube and anus (*b*). On either side of the anterior portion of the body, are six or more narrow fin-like appendages, which are fringed with cilia; and the posterior part of the body is prolonged into a sort of pedicle, bilobed towards its extremity, which also is covered with cilia.

the posterior part of the body is prolonged into a sort of pedicle, bilobed towards its extremity, which also is covered with cilia.

The organisation of this larva seems completed, and its movements through the water are very active, before the mass at its anterior extremity presents anything of the aspect of the Star-fish; in this respect corresponding with the movements of the 'pluteus' of the Echinida (§ 322). The temporary mouth of the larva does not remain as the permanent mouth of the Star-fish; for the œsophagus of the latter enters on what is to become the dorsal side of its body, and the true mouth is subsequently formed by the thinning-away of the integument on its ventral surface. The young Star-fish is separated from the bipinnarian larva, by the forcible contractions of the connecting pedicle, as soon as the calcareous consolidation of its integument has taken-place, and its true mouth has been formed, but long before it has attained the adult condition; and as its ulterior development has not hitherto been observed in any instance, it is not yet known what are the species in which this mode of evolution prevails. The larva continues active for several days after its detachment; and it is possible, though perhaps scarcely probable, that it may develop another Asteroid by a repetition of this process of gemmation.*

322. In the Bipinnaria, as in other larva-zooids of the Asterozoa, there is no internal calcareous frame-work; such a frame-work, however, is found in the larvæ of the Echinida and Ophiurida, of which the form delineated in Fig. 244 is an example.† The embryo issues from the ovum as soon as it has attained, by the repeated segmentation of the yolk, the condition of the 'mulberry-mass;' and the superficial cells of this are covered with cilia, by whose agency it swims freely through the water. So rapid are the early processes of development, that no more than from twelve to twenty-four hours intervene between fecundation and the emersion of the embryo; the division into two, four, or even eight segments taking-place within three hours after impregnation. Within a few hours after its emersion, the embryo changes from the spherical into a sub-pyramidal form with a flattened base; and

* See the Observations of Koren and Danielsen (of Bergen) in the "Zoologiske Bidrag," Bergen, 1847 (translated in the "Ann. des Sci. Nat.," 3e Sér., Zool., tom. iii., p. 347); and the Memoir of Prof. Müller 'Über die Larven und die Metamorphose der Echinodermen,' in "Abhandlungen der Königlichen Akademie der Wissenschaften zu Berlin," 1848.

† See Prof. Müller, 'Ueber die Larven und die Metamorphose der Ophiuren und Seeigel,' in "Abhandlungen der Königlichen Akademie der Wissenschaften zu Berlin," 1846. See also, for the earlier stages, a Memoir by M. Derbès, in "Ann. des Sci. Nat.," 3e Sér., Zool., tom. viii., p. 80; and for the later, Krohn's "Beitrag zur Entwicklungsgeschichte der Seeigellarven," Heidelberg, 1849, and his Memoir in "Müller's Archiv.," 1851.

in the centre of this base is a depression, which gradually deepens, so as to form a mouth that communicates with a

FIG. 244.

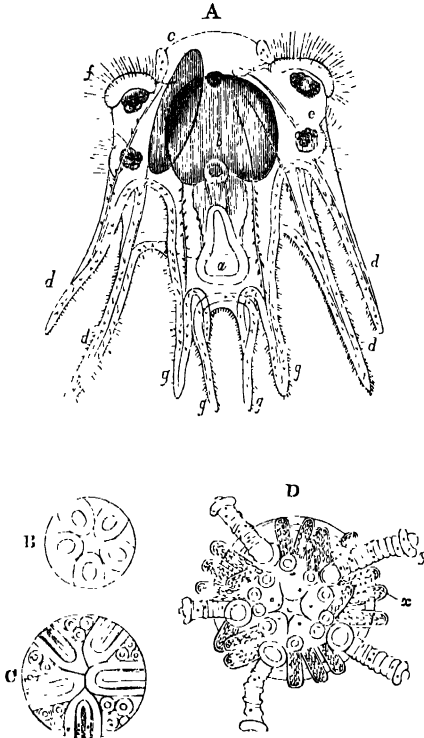

Embryonic development of *Echinus*:—A, *Pluteus larva* at the time of the first appearance of the disc; a, mouth in the midst of the four-pronged proboscis; b, stomach; c, echinoid disc; d, d, d, d, four arms of the pluteus-body; e, calcareous framework; f, ciliated lobes, g, g, g, g, ciliated processes of the proboscis —b, disc with the first indication of the cirrhi —c, disc, with the origin of the spines between the cirrhi —d, more advanced disc, with the cirrhi and spines projecting considerably from the surface. (N B. In figs. B, c, and d, the pluteus is not represented, its parts having undergone no change, save in becoming relatively smaller.)

cavity in the interior of the body, which is surrounded by a portion of the yolk-mass that has returned to the liquid granular state. Subsequently a short intestinal tube is found, with an anal orifice, opening on one side of the body. The pyramid is at first triangular, but it afterwards becomes quadrangular; and the angles are greatly prolonged round the mouth (or base), whilst the apex of the pyramid is sometimes much extended in the opposite direction, but is sometimes rounded-off into a kind of dome (Fig. 244, A). All parts of this curious body, and especially its most projecting portions, are strengthened by a frame-work of thread-like calcareous rods (*e*). In this condition, the embryo swims freely through the water, being propelled by the action of cilia, which clothe the four angles of the pyramid and its projecting arms, and which are sometimes thickly set upon two or four projecting lobes (*f*); and it has received the designation of *Pluteus*. The mouth is usually surrounded by a sort of proboscis, the angles of which are prolonged into four slender processes (*g, g, g, g*), shorter than the four outer legs, but furnished with a similar calcareous frame-work.

323. The first indication of the production of the young *Echinus* from its 'pluteus,' is given by the formation of a circular disc (Fig. 244, A, *e*), on one side of the central stomach (*b*); and this disc soon presents five prominent tubercles (*v*), which subsequently become elongated into tubular cirrhi. The disc gradually extends itself over the stomach, and between its cirrhi the rudiments of spines are seen to protrude (*c*); these, with the cirrhi, increase in length, so as to project against the envelope of the 'pluteus,' and to push themselves through it; whilst, at the same time, the original angular appendages of the 'pluteus' diminish in size, the ciliary movement becomes less active, being superseded by the action of the cirrhi and spines, and the mouth of the 'pluteus' closes-up. By the time that the disc has grown over half of the gastric sphere, very little of the 'pluteus' remains, except some of the slender calcareous rods; and the number of tentacula and spines rapidly increases. The calcareous frame-work of the shell at first consists, like that of the Star-fishes, of a series of isolated networks developed between the cirrhi; and upon these rest the first-formed spines (*v*). But they gradually become more consolidated, and extend themselves over the granular mass, so as to form the series of plates. The mouth of the *Echinus* (which is altogether distinct from that of the 'pluteus') is formed at

that side of the granular mass, over which the shell is last extended; and the first indication of it consists in the appearance of five calcareous concretions, which are the summits of the five portions of the frame-work of jaws and teeth that surround it. All traces of the original 'pluteus' are now lost; and the larva, which now presents the general aspect of an Echinoid animal, gradually augments in size, multiplies the number of its plates, cirrhi, and spines, evolves itself into its particular generic and specific type, and undergoes various changes of internal structure, tending to the development of the complete organism.—In collecting the free-swimming larvæ of Echinodermata, a fine muslin net should be employed in the manner already described (§ 306); and the search for them is of course most likely to be successful in those localities, in which the adult animals of the respective species abound, and on warm calm days, in which they seem to come to the surface in the greatest numbers.

324. It is remarkable that the *Comatula*, one of the most active of all Echinoderms in its adult state, passes a portion of the early period of its life in a fixed condition; being attached by a stem to sea-weeds or zoophytes, precisely after the manner of the *Crinoids* or 'lily-stars,' which were the most common types of this class in the older epochs of the world's history. In this phase of its life, which was first discovered by Mr. J. V. Thompson of Cork, in 1823, it is very minute, and forms a most beautiful object for the lower magnifying powers, when viewed in fluid by a strong incident light, as nearly as possible in its natural condition. It has hitherto been found so rarely, however, that few Microscopists have been able to become possessed of it; but the Author has been fortunate enough to discover a locality (Lamlash Bay, in the Isle of Arran) in which it is so abundant, that it may hereafter find its way into almost every cabinet.—It has been made next to certain by the observations of Busch, that this fixed stage is preceded by a free-swimming larval condition; and the passage from one phase to the other is a problem of the greatest interest, which the Author hopes to have it in his power to work-out.

CHAPTER XIII.

POLYZOA, AND COMPOUND TUNICATA.

At the lower extremity of the great series of Molluscous animals, we find two very remarkable groups, whose mode of life has much in common with Zoophytes, whilst their type of structure is conformable in all essential particulars to that of the true Mollusks. These animals are for the most part microscopic in their dimensions; and as some members of both these groups are found on almost every coast, and are most interesting objects for anatomical examination, as well as for observation in the living state, a brief general account of them will be here appropriate.

325. *Polyzoa*.—The group which is known under this name to British naturalists, corresponds with that which by Continental zoologists is designated *Bryozoa*: the former name (though first used in the singular instead of the plural number), having been introduced by Mr. J. V. Thompson in a memoir published in 1830, seems to have precedence in point of time over the latter, which was conferred by Prof. Ehrenberg in 1831 on a most heterogeneous group, wherein the *Bryozoa*, as now limited, were combined with the *Foraminifera*. As the history of the researches by which the *Polyzoa* have been raised from the class of Zoophytes (in which they were formerly ranked, for the most part in apposition with the *Hydrozoa*,) to the Molluscan sub-kingdom, has already been sketched (p. 20), we may now proceed, without further preface, to a survey of the leading features of their organisation.—The animals of the *Polyzoa*, in consequence of their universal tendency to multiplication by gemmation, are seldom or never found solitary, but form clusters or colonies of various kinds; and as each is enclosed in either a horny or a calcareous sheath, or ‘cell,’ a composite structure is formed, closely corresponding with the polypidom of a Zoophyte, which has been appropriately designated the ‘polyzoary.’ The individual cells of the ‘polyzoary’ are sometimes only connected with each other by their common relation to a creeping stem

or 'stolon,' as in *Laguncula* (Fig. 246); but more frequently they bud forth directly, one from another, and extend themselves in different directions over plane surfaces, as is the case with *Flustra*, *Leprotiae*, &c. (Fig. 245); whilst not unfre-

FIG. 245.

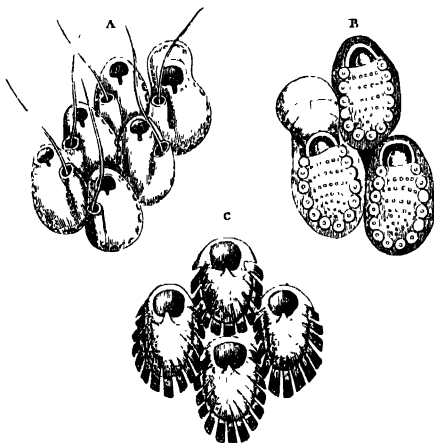

Cells of *Leprotiae*:—A, *L. Hyndmanni*; B, *L. figularis*; C, *L. verrucosa*.

quently the Polyzoary develops itself into an arborescent structure (Fig. 247), which may even present somewhat of the density and massiveness of the stony Corals. Each individual is composed externally of a sort of sac, of which the outer or tegumentary layer is either simply membranous, or is horny, or in some instances calcified, so as to form the cell; this investing sac is lined by a more delicate membrane, which closes its orifice, and which then becomes continuous with the wall of the alimentary canal; this lies freely in the visceral sac, floating (as it were) in the liquid which it contains. The further details of the anatomy will be best understood from the examination of a characteristic example, such as the *Laguncula repens*; which is shown in the state of expansion at A, Fig. 246, and in the state of contraction at B and C. The mouth is surrounded by a circle of tubular tentacula,

FIG. 246.

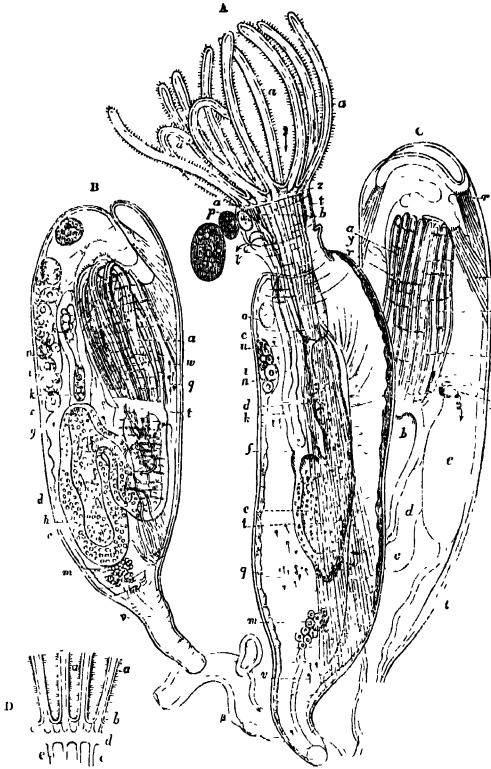

Laguncula repens, as seen in its expanded state at a, and in its contracted state, in two different aspects, at b and c. The same references answer for each figure — a a, tentacula clothed with vibratile cilia, b, pharyngeal cavity; c, valve separating this cavity from d the œsophagus; e, the stomach, with f its pyloric valve, and g the circle of cilia surrounding that orifice, h, wall of the stomach with biliary follicles; i, the intestine, containing k excrementitious matter, and terminating at l the anus; m, the testicle; n, the ovary; o, an ovum set free from the ovary; p, openings for the escape of the ova; q, spermatozoa freely moving in the cavity that surrounds the viscera, r, retractor muscle of the angle of the aperture of the sheath;

which are clothed with vibratile cilia; these tentacula, in the species we are considering, vary from ten to twelve in number; but in some other instances they are more numerous. By the ciliary investment of their tentacula, the Polyzoa are at once distinguishable from those Hydraform polypes to which they bear a superficial resemblance, and with which they were at one time confounded; and accordingly, whilst still ranked among the Zoophytes, they were characterized as *Ciliobrachyata*. The tentacula are seated upon an annular disk, which is termed the 'lophophore,' and which forms the roof of the visceral or perigastric cavity; and this cavity extends itself into the interior of the tentacula, through perforations in the 'lophophore.' The mouth, situated in the centre of the 'lophophore,' leads to a funnel-shaped cavity, or pharynx, *b*, which is separated from the œsophagus, *d*, by a valve at *c*; and this œsophagus opens into the stomach, *e*, which occupies a considerable part of the visceral cavity. In the *Bowerbankia*, and some other Polyzoa, a muscular stomach or gizzard, for the trituration of the food, intervenes between the œsophagus and the true digestive stomach. The walls of the stomach, *h*, have considerable thickness; and they are beset with minute follicles, which seem to have the character of a rudimentary liver. This, however, is more obvious in some other members of the group. The stomach is lined, especially at its upper part, with vibratile cilia, as seen at *c, g*; and by the action of these, the food is kept in a state of constant agitation during the digestive process. From the upper part of the stomach, which is (as it were) doubled upon itself, the intestine *i* opens, by a pyloric orifice *f*, which is furnished with a regular valve; within the intestine are seen at *k* particles of excrementitious matter; which are discharged by the anal orifice at *l*. No circulating apparatus here exists; but the liquid which fills the cavity that surrounds the viscera, contains the nutritive matter which has been prepared by the digestive operation, and which has transuded through the walls of the alimentary canal; a few corpuscles of irregular

e, retractor of the sheath; *t*, retractor of the tentacular circle; *u*, retractor of the œsophagus; *v*, retractor of the stomach; *w*, principal extensor muscle, *x*, transverse wrinkles of the sheath, *y*, fibres of the sheath, themselves probably muscular; *z*, muscles of the tentacula; *a* (at the base of the tentacular circle in Δ), nervous or œsophageal ganglion; β , stem.—*n*, a portion of the tentacular circle shown separately on a larger scale; *a a*, the tentacula clothed with cilia; *b b*, their internal canals, *c*, muscles of the tentacula; *d*, transverse muscles forming a ring at the base of the tentacula; *e*, muscles of the tentacular circle.

size are seen to float in it. The visceral sacs of the different individuals put-forth from the same stem, appear to communicate with each other. No other respiratory organs exist than the tentacula; into whose cavity the nutritive fluid is probably sent from the visceral cavity, for aeration by the current of water that is continually flowing over them.

326. The production of gemmæ may take-place either from the bodies of the animals themselves, which is what always happens when the cells are in mutual apposition; or from the connecting stem or stolon, where the cells are detached from each other, as in *Laguncula*. There is first seen a bud-like protuberance of the horny external integument, into which the soft membranous lining prolongs itself; the cavity thus formed, however, is not to become (as in *Hydra* and its allies) the stomach of the new zooid; but it constitutes the chamber surrounding the digestive viscera, which organs have their origin in a thickening of the lining membrane, that projects from one side of the cavity into its interior, and gradually shapes itself into the alimentary canal with its tentacular appendages. Of the production of gemmæ from the zooids themselves, the best examples are furnished by the *Flustra* and their allies. From a single cell of a *Flustra*, five such buds may be sent-off, which develope themselves into new zooids around it; and these, in their turn, produce buds from their unattached margins, so as rapidly to augment the number of cells to a very large amount. To this extension there seems no definite limit; and it often happens that the cells in the central portion of the leaf-like expansion of a *Flustra* are devoid of contents and have lost their vitality, whilst the edges are in a state of active growth.—Independently of their propagation by gemmation, the *Polyzoa* have a true sexual generation; the sexes, however, being usually, if not invariably, united in the same individuals. The sperm-cells are developed in a glandular body, the testicle *m*, which lies beneath the base of the stomach; when mature, they rupture, and set free the spermatozoa *q q*, which swim freely in the liquid of the visceral cavity. The ova, on the other hand, are formed in an ovarium *n*, which is lodged in the membrane lining the tegumentary sheath, near its outlet; the ova, having escaped from this into the visceral cavity, as at *o*, are fertilized by the spermatozoa which they there meet-with; and are finally discharged by an outlet at *p*, beneath the tentacular circle

327. These creatures possess a considerable number of

muscles, by which their bodies may be projected from their sheaths or drawn within them; of these muscles, *r, s, t, u, v, w, x*, the direction and points of attachment sufficiently indicate the uses; they are for the most part *retractors*, serving to draw-in and double-up the body, to fold-together the circle of tentacula, and to close the aperture of the sheath, when the animal has been completely withdrawn into its interior. The projection and expansion of the animal, on the contrary, appear to be chiefly accomplished by a general pressure upon the sheath, which will tend to force-out all that can be expelled from it. The tentacula themselves are furnished with distinct muscular fibres, by which their separate movements seem to be governed; the arrangement of these is seen at *D*. At the base of the tentacular circle, just above the anal orifice, is a small body (seen at *A, a*), which is a nervous ganglion; as yet no branches have been distinctly seen to be connected with it in this species; but its character is less doubtful in some other Polyzoa.

328. If we scrutinize the foregoing characters, we shall find that the most important of them are Molluscan, rather than Zoophytic. In the first place, all true Polyzoa use their tentacula to grasp their food and convey it to the mouth; and these tentacula are destitute of cilia; whilst, on the other hand, in all the Acephalous Mollusca, the nutritive matter is drawn-in by a ciliary current, which also serves to aerate the fluids. Now the latter, as we have just seen, is the case with the Polyzoa; and thus, although their arms very commonly present a circular disposition around the mouth, they may be considered as representing, in their relation to the economy of the animal, the ciliated branchial sac of the Ascidians (§ 331). But they do not by any means constantly present this radial symmetry: thus, in the *Plumatella*, a beautiful fresh-water genus of Polyzoa, the ciliated arms are set upon two lobes or projections, one on either side of the mouth. The structure of the alimentary canal, again, removes the Polyzoa from the zoophytic series. In no true polype is there a separate intestine and anal orifice, nor does the whole apparatus hang freely in the visceral cavity; and the existence of a gizzard-like organ, and of a rudimentary liver (closely resembling that found in the lowest Tunicata), are also characters of elevation. The most important of all the single characters furnished by the anatomy of these animals, is their nervous system; which, as already pointed-out, is distinctly Molluscan in its type. The absence of a heart and a distinct circulating system is, it

is true, a Zoophytic character; but we shall presently find that even in the Tunicata, which are true Mollusks, the character of the circulating apparatus is extremely degraded. The propagation by gemmation, although formerly supposed to be a character exclusively Zoophytic, is known to belong also to the greater part of the 'tunicated' Mollusks; and from this, therefore, no argument can be drawn in favour of the zoophytic nature of the Polyzoa. And although many of their composite fabrics have a stony density, and closely resemble the solid polypidoms of the helianthoid and asteroid Polypes, yet in others, especially amongst the fresh-water species, we find a very close resemblance to the gelatinous bed or leathery crust in which the Compound Ascidians are lodged; and if we imagine calcareous matter to be deposited in this bed or crust, we should have a fabric closely resembling that of many stony polyzoaries.

329. Of all the Polyzoa of our own coasts, the *Flustræ* or 'sea-mats' are the most common; these present flat expanded surfaces, resembling in form those of many sea-weeds (for which they are often mistaken), but exhibiting, when viewed even with a low magnifying power, a most beautiful network, which at once indicates their real character. The cells are arranged on both sides; and it has been calculated by Dr. Grant, that as a single square inch of an ordinary *Flustra* contains 1800 such cells, and as an average specimen presents about 10 square inches of surface, it will consist of no fewer than 18,000 zooids. The want of transparency in the cell-wall, however, and the infrequency with which the animal projects its body far beyond the mouth of the cell, renders the Polyzoa of this genus less favourable subjects for microscopic examination, than are those of the *Bowerbankia*, a Polyzoon with a trailing stem and separated cells like those of *Laguncula*, which is very commonly found clustering around the bases of *Flustræ*. It was in this, that many of the details of the organization of the interesting group we are considering, were first studied by Dr. A. Farre, who discovered it in 1837, and subjected it to a far more minute examination than any Polyzoon had previously received;* and it is one of the best-adapted of all the marine forms yet known, for the display of the beauties and wonders of this type of organization. The *Halodactylus* (formerly called *Alcyonidium*), however, is among the most remarkable of all the marine forms, for the

* See his Memoir in the "Philosophical Transactions" for that year.

comparatively large size of the tentacular crowns; these, when expanded, being very distinctly visible to the naked eye, and presenting a spectacle of the greatest beauty when viewed under a sufficient magnifying power. The polyzoary of this genus has a spongy aspect and texture, very much resembling that of the Alcyonian Zoophytes, for which it might readily be mistaken when its contained animals are all withdrawn into their cells; when these are expanded, however, the aspect of the two is altogether different, as the minute plumose tufts which then issue from the surface of the Halodactylus, making it look as if it were covered with the most delicate downy film, are in striking contrast with the larger, solid-looking polypes of the Alcyonium. The opacity of the polyzoary of the Halodactylus renders it quite unsuitable for the examination of anything more than the tentacular crown and the œsophagus which it surmounts; the stomach and the remainder of the visceral apparatus being always retained within the cell.—Several of the freshwater Polyzoa are peculiarly interesting subjects for microscopic examination; alike on account of the remarkable distinctness with which the various parts of their organization may be seen, and the very beautiful manner in which their ciliated tentacula are arranged upon a deeply-crescentic or horseshoe-shaped ‘lophophore.’ By this peculiarity, the fresh-water Polyzoa are separated as a distinct sub-class from the marine; the former being designated as *Hippocrepia* (horseshoe-like), while the latter are termed *Infundibulata* (funnel-like).

330. The *Infundibulata* or Marine Polyzoa, constituting by far the most numerous division of the class, are divided into our orders, as follows:—I. *Cheilostomata*, in which the mouth of the cell is sub-terminal, or not quite at its extremity (Fig. 245), is somewhat crescentic in form, and is furnished with a moveable (generally membranous) lip, which closes it when the animal retreats. This includes a large part of the species that most abound on our own coasts, notwithstanding their wide differences in form and habit. Thus the polyzoaries of some (as *Flustra*) are horny and flexible, whilst those of others (as *Eschara* and *Retepora*) are so penetrated with calcareous matter as to be quite rigid; some grow as independent plant-like structures (as *Bugula* and *Gemellaria*), whilst others, having a like arborescent form, creep over the surfaces of rocks or stone (as *Hippothoa*), and others, again, have their cells in close apposition, and form crusts which possess no definite figure (as is the case with *Lepralia* and

Membranipora). A large proportion of the Polyzoa of this order are furnished with very peculiar motile appendages, which are of two kinds, *avicularia* and *vibracula*. The 'avicularia,' or 'bird's-head processes,' are so named from the striking resemblance they present to the head and jaws of a bird (Fig. 247, B). They are generally 'sessile' upon the angles or margins of the cells, that is, are attached at once to them,

FIG 247.



A, Portion of *Cellularia ciliata*, enlarged; B, one of the 'bird's-head processes' of *Bugula avicularia*, more highly magnified, and seen in the act of grasping another.

without the intervention of a stalk, as in Fig. 247, A, being either 'projecting' or 'immersed;' but in the genera *Bugula* and *Bicellaria*, where they are present at all, they are 'pedunculate' or mounted on footstalks (B). Under one form or the other, they are wanting in but few of the genera belonging to this order; and their presence or absence furnishes valuable

characters for the discrimination of species. Each avicularium has two 'mandibles,' of which one is fixed, like the upper jaw of a bird, the other moveable like its lower jaw; the latter is opened and closed by two sets of muscles which are seen in the interior of the 'head;' and between them is a peculiar body, furnished with a pencil of bristles, which is probably a tactile organ, being brought forwards when the mouth is open, so that the bristles project beyond it, and being drawn-back when the mandible closes. The 'avicularia' keep-up a continual snapping action, during the life of the polyzoary; and they may often be observed to lay hold of minute worms or other bodies, sometimes even closing upon the beaks of adjacent organs of the same kind, as shown in Fig. 247, B. In the pedunculate forms, besides the snapping action, there is a continual rhythmical nodding of the head upon the stalk; and few spectacles are more curious than a portion of the polyzoary of *Bugula avicularia* (a very common British species) in a state of active vitality, when viewed under a power sufficiently low to allow a number of these bodies to be in sight at once. It is still very doubtful what is their precise function in the economy of the animal; whether it is to retain bodies that may serve as food within the reach of the ciliary current; or whether it is, like the 'pedicellaria' of Echini (§ 314), to remove extraneous particles that may be in contact with the surface of the polyzoary. The latter would seem to be the function of the *vibracula*, which are long bristle-shaped organs, each one springing at its base out of a sort of cup (Fig. 245, A), that contains muscles by which it is kept in almost constant motion, sweeping slowly and carefully over the surface of the polyzoary, and removing what might be injurious to the delicate inhabitants of the cells when their tentacula are protruded. Out of 191 species of Cheilostomatous Polyzoa described by Mr. Busk, no fewer than 126 are furnished either with 'avicularia,' or with 'vibracula,' or with both these organs.*—II The second order, *Cyclostomata*, consists of those Polyzoa which have the mouth at the termination of tubular calcareous cells, without any moveable appendage or lip. This includes a comparatively small number of genera, of which *Crisia* and *Tubulipora* contain the largest proportion of the species that occur on our own coasts.—III. The distinguishing character of the

* See Mr. G. Busk's 'Remarks on the Structure and Function of the Avicularian and Vibracular Organs of Polyzoa,' in "Transact. of Microscop. Soc.," Ser 2, vol. n. p. 26.

third order, *Ctenosomata*, is derived from the presence of a comb-like circular fringe of bristles, connected by a delicate membrane, around the mouth of the cell, when the animal is projected from it; this fringe being drawn-in when the animal is retracted. The polyzoaries of this group are very various in character, the cells being sometimes horny and separate (as in *Laguncula* and *Bowerbankia*), sometimes fleshy and coalescent (as in *Halodactylus*).—IV. In the fourth order, *Pedicellineæ*, which includes only a single genus, *Pedicellina*, the lophophore is produced upwards on the back of the tentacles, uniting them at their base in a sort of muscular calyx, and giving to the animal when expanded somewhat the form of an inverted bell, like that of *Vorticella* (Fig. 196).—Among the *Hippocrepia* may be noticed, as exceptional forms, the *Cristatella*, whose polyzoary is unattached, so as to be capable of moving freely through the water, and the *Fredericella*, the lophophore of which is rather circular than crescentic, the prolongation being so slight as only to be discernible on a careful examination. Generally speaking, the cells are lodged in a sort of gelatinous substratum, which spreads over the leaves of aquatic plants, sometimes forming masses of considerable size. As the animals of this group altogether resemble the true Zoophytes in their habits, and are found in the same localities, it is not requisite to add anything to what has already been said (§ 305) respecting the collection, examination, and mounting, of this very interesting class of objects.*

331. *Compound Tunicata*.—The Tunicated Mollusca are so named from the enclosure of their bodies in a 'tunic,' which is sometimes leathery or even cartilaginous in its texture, and which very commonly includes calcareous spicules, whose forms are often very beautiful. They present a strong resemblance to the Polyzoa, not merely in their general plan of conformation, but also in their tendency to produce composite structures by gemmation; they are differentiated from them, however, by the absence of the ciliated tentacula, which form so conspicuous a feature in the external aspect of the Polyzoa, by the presence of a distinct circulating apparatus, and by their peculiar respiratory apparatus, which may be regarded as a dilatation

* For a more detailed account of the Structure and Classification of this group, see Prof. Allman's 'Report on the Freshwater Polyzoa' in the "Transactions of the British Association" for 1850; Prof. Van Beneden's 'Recherches sur les Bryozoaires de la Côte d'Ostende,' in "Mem. de l'Acad. Roy. de Bruxelles," tom. xvii.; Mr. G. Busk's 'Catalogue of the Marine Polyzoa in the Collection of the British Museum;' and Dr. G. Johnston's "History of British Zoophytes."

of their pharynx. In their habits, too, they are more inactive, exhibiting scarcely anything comparable to those rapid movements of expansion and retraction, which it is so interesting to watch among the Polyzoa; whilst, with the exception of the *Salpidae* and other floating species which are chiefly found in seas warmer than those that surround our coast, they are rooted to one spot during all but the earliest period of their lives. The larger forms of the Ascidian group, which constitutes the bulk of the class, are always solitary; either not propagating by gemmation at all, or, if this process does take place, the gemmæ being detached before they have advanced far in their development. Since these cannot be considered as Microscopic objects (although no part of their organization can be properly made-out without the assistance of that instrument), our attention will be confined to those 'Compound Ascidiæ,' the small size and transparency of whose bodies, when detached from the mass in which they are imbedded, not only enables their structure to be clearly discerned without dissection, but allows many of their living actions to be watched. Of these we have a characteristic example in *Amaroucium proliferum*; of which the form of the composite mass and the anatomy of a single individual are displayed in Fig. 248. The clusters of these animals present themselves on rocks, sea-weeds, &c., very commonly between the tide-marks. They appear almost completely inanimate, exhibiting no very obvious movements when irritated; but if they be placed when fresh in sea-water, a slight pouting of the orifices will soon be perceptible, and a constant and energetic series of currents will be found to enter by one set and to be ejected by the other, indicating that all the machinery of active life is going on within these apathetic bodies. In the tribe of *Polyclinians*, to which this genus belongs, the body is elongated, and may be divided into three regions, the thorax (A) which is chiefly occupied by the respiratory sac, the abdomen (B) which contains the digestive apparatus, and the post-abdomen (C) in which the heart and generative organs are lodged. At the summit of the thorax is seen the oral orifice *c*, which leads to the branchial sac *e*; this is perforated by an immense number of slits, which allow part of the water to pass into the space between the branchial sac and the muscular mantle, where it is especially collected in the thoracic sinus *f*. At *k* is seen the œsophagus, which is continuous with the lower part of the pharyngeal cavity; this leads to the stomach *l*, which is surrounded by biliary tubuli; and

FIG. 248.



Compound mass of *Amaroucium proliferum*, with the anatomy of a single zooid.—A, thorax; B, abdomen; C, post-abdomen—*c*, oral orifice; *e*, branchial sac; *f*, thoracic sinus; *g*, anal orifice; *g'*, projection overhanging it; *h*, nervous ganglion; *k*, œsophagus; *l*, stomach surrounded by biliary tubuli, *m*, intestine; *n*, termination of intestina in cloaca, *o*, heart; *o'*, pericardium; *p*, ovarium; *p'*, egg ready to escape, *q*, testis; *r*, spermatic canal; *r'*, termination of this canal in the cloaca.

from this passes-off the intestine *m*, which terminates at *n* in the cloaca. The long post-abdomen is principally occupied by the large ovarium *p*, which contains ova in various stages of development. These, when matured and set-free, find their way into the cloaca; where two large ova are seen (one marked *p'*, and the other immediately below it,) waiting for expulsion. In this position they receive the fertilizing influence from the testis *q*, which discharges its products by the long spermatic canal *r*, that opens into the cloaca at *r'*. At the very bottom of the post-abdomen, we find the heart *o*, enclosed in its pericardium *o'*.—In the tribe we are now considering, a number of such animals are imbedded together in a sort of gelatinous mass, and covered with an integument common to them all; the composi-

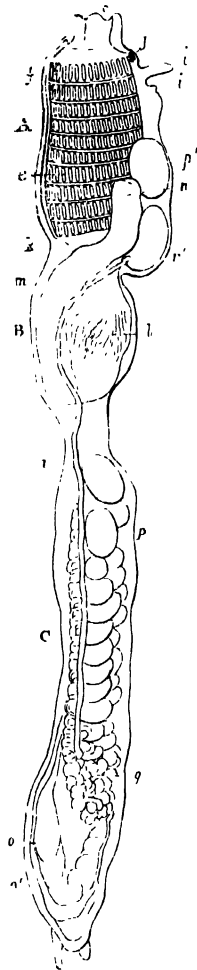

tion of this gelatinous substance is remarkable as including 'cellulose,' which generally ranks as a purely vegetable product. The mode in which new individuals are developed in this mass, is by the extension of 'stolons' or creeping stems from the bases of those previously existing; and from each of these stolons several buds may be put-forth, every one of which may evolve itself into the likeness of the stock from which it proceeded, and may in its turn increase and multiply after the same fashion. A communication between the circulating systems of the different individuals is kept-up, through their connecting stems, during the whole of life; and thus their relationship to each other is somewhat like that of the several polypes on the polypidom of a *Campanularia* (§ 304).

332. In the family of *Didemnians*, the post-abdomen is absent, the heart and generative apparatus being placed by the side of the intestine in the abdominal portion of the body. The zooids are frequently arranged in star-shaped clusters, their anal orifices being all directed towards a common vent which occupies the centre.—This shortening is still more remarkable, however, in the family of *Botryllians*, whose beautiful

FIG. 249.

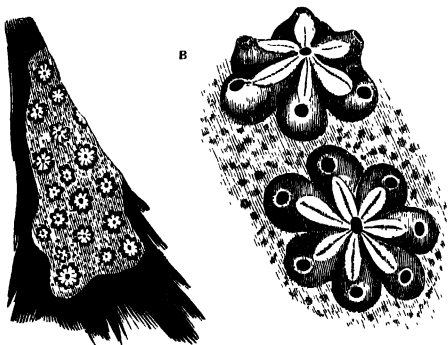

Botryllus violaceus :—A, cluster on the surface of a Fucus —B, portion of the same enlarged.

stellate gelatinous incrustations are extremely common upon sea-weeds and submerged rocks (Fig. 249). The anatomy of

these animals is very similar to that of the *Amaroucium* already described; with this exception, that the body exhibits no distinction of cavities, all the organs being brought together in one, which must be considered as thoracic. In this respect, there is an evident approximation towards the solitary species.

333. This approximation is still closer, however, in the 'social' Ascidiæ, or *Clavellinidæ*; in which the general plan of structure is nearly the same, but the zooids are simply

FIG. 250.

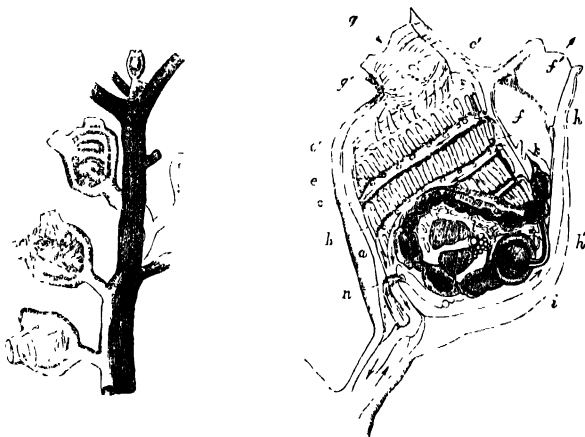

A, Group of *Perophora* (enlarged), growing from a common stalk:—B, single *Perophora*; a, test; b, inner sac; c, branchial sac, attached to the inner sac along the line c' c'; e, e, finger-like processes projecting inwards, f, cavity between test and internal coat; f', anal orifice or funnel, g, oral orifice; g', oral tentacula; h, downward stream of food, h', œsophagus; i, stomach; k, vent; l, ovary (?); n, vessels connecting the circulation in the body with that in the stalk.

connected by their stolons, instead of being included in a common investment (Fig. 250); so that their relation to each

other is very nearly the same as that of the zooids of *Laguncula* (§ 322), the chief difference being that a regular circulation takes place through the stolon in the one case, such as has no existence in the other. A better opportunity of studying the living actions of the Ascidians can scarcely be found, than that which is afforded by the genus *Perophora*, first discovered by Mr. Lister, which occurs not unfrequently on the south coast of England and in the Irish Sea, living attached to seaweeds, and looking like an assemblage of minute globules of jelly, dotted with orange and brown, and linked by a silvery winding thread. The isolation of the body of each zooid from that of its fellows, and the extreme transparency of its tunics, not only enable the movements of fluid within the body to be distinctly discerned, but also allow the action of the cilia that border the slits of the respiratory sac to be clearly made-out. This sac is perforated with four rows of narrow oval openings, through which a portion of the water that enters its branchial orifice (*g*) escapes into the space between the sac and the mantle, and is thus discharged immediately by the funnel (*f*). Whatever little particles, animate or inanimate, the current of water brings, flow into the sac, unless stopped by the tentacula (*g'*) at its entrance, which do not appear fastidious. The particles which are admitted usually lodge somewhere on the sides of the sac, and then travel horizontally until they arrive at that part of it down which the current proceeds to the entrance of the stomach (*i*), which is situated at the bottom of the sac. Minute animals are often swallowed alive, and have been observed darting-about in the cavity for some days, without any apparent injury either to themselves or to the creature which encloses them. In general, however, particles which are unsuited for reception into the stomach, are ejected by the sudden contraction of the mantle (or muscular tunic), the vent being at the same time closed, so that they are forced-out by a powerful current through the branchial orifice.

334. The Circulation of blood, throughout the entire class, is remarkable for the *alternation* which it presents, from time to time, in the direction of its flow; and this curious phenomenon may be particularly well studied in the *Perophora*. The creeping-stalk (Fig. 250) that connects the individuals of any group, contains two distinct canals, which send-off branches into each peduncle. One of these branches terminates in the heart, which is nothing more than a contractile dilatation of the principal trunk; this trunk subdivides into vessels (or

rather *sinuses*, which are mere channels not having proper walls of their own), of which some ramify over the respiratory sac, branching-off at each of the passages between the oval slits, whilst others are first distributed to the stomach and intestines, and to the soft surface of the mantle. All these reunite, and form a trunk which passes to the peduncle, and constitutes the returning branch. Now whilst at some periods, the heart may be seen vigorously contracting from behind forwards, so as to propel the blood along the course just described, the observer, if he continue to watch, will see its pulsations becoming fainter for a few beats, and the flow in the vessels becoming slower; and then, after a slight pause, the whole current in all its windings is reversed. The heart gives the opposite impulse, receiving the blood from the body, and sending it back into the peduncle through the tube that previously conveyed it thence; while the tube that had previously served to carry the returning stream, now brings the blood from the stem, and distributes it to the branchial sac, mantle, and visceral apparatus, whence it finds its way back to the heart. After the circulation has continued for a certain time in this new direction, the intermission is repeated; and then a reversal takes place to the first course. The average time during which the circulation persists in each direction, seems to be about the same for the one as for the other; but the period between the changes varies as much as from thirty seconds to two minutes. Although the circulation in the different bodies is brought into connection by the common stem, yet that of each is independent of the rest, continuing when the current through its own footstalk is interrupted by a ligature; and the stream which returns from the branchial sac and the viscera is then poured into the posterior part of the heart, instead of entering the peduncle. This is the course which it takes in the 'solitary' Ascidians; and also in those composite forms, whose connecting stolons do not contain blood-vessels.

335. The development of the Ascidians presents some phenomena of much interest to the Microscopist; the early stages of which are observable, whilst the ova are still within the cloaca of the parent. After the ordinary repeated segmentation of the yolk, whereby a 'mulberry mass' is produced, a sort of ring is seen, encircling its central portion; but this soon shows itself as a tapering tail-like prolongation from one side of the yolk, which gradually becomes more and more detached from it, save at the part from which it springs. Either whilst the

egg is still within the cloaca, or soon after it has escaped from the vent, its envelope bursts, and the larva escapes; and in this condition it presents very much the appearance of a tadpole, the tail being straightened-out, and propelling the body freely through the water by its lateral strokes. The centre of the body is occupied by a mass of liquid yolk; and this is continued into the interior of three prolongations which extend themselves from the opposite extremity, each terminating in a sort of sucker. After swimming-about for some hours with an active wriggling movement, the larva attaches itself to some solid body by means of one of these suckers; if disturbed from its position, it at first swims-about as before; but it soon completely loses its activity, and becomes permanently attached; and important changes manifest themselves in its interior. The prolongations of the central yolk-substance into the anterior processes and tail are gradually drawn back, so that the whole of it is concentrated into one mass; and the tail, now consisting only of the gelatinous envelope, is either detached entire from the body by the contraction of the connecting portion, or withers and is thrown-off gradually in shreds. The shaping of the internal organs out of the yolk-mass, takes-place very rapidly; so that by the end of the second day of the sedentary state, the outlines of the branchial sac and of the stomach and intestine may be traced; no external orifices, however, being as yet visible. The pulsation of the heart is first seen on the third day, and the formation of the branchial and anal orifices takes-place on the fourth; after which the ciliary currents are immediately established through the branchial sac and alimentary canal.—The embryonic development of other Ascidians, solitary as well as composite, takes-place on a plan essentially the same as the foregoing, a free tadpole-like larva being always produced in the first instance; and in the curious *Appendicularia*, which occasionally presents itself on our own coasts, this larval form is retained through life.*

* For more special information respecting the Compound Ascidians, see especially the admirable Monograph of Prof. Milne-Edwards on that group, Mr. Lister's Memoir 'On the Structure and Functions of Tubular and Cellular Polypi, and of Ascidia,' in the "Philos. Transact.," 1834, and Mr. Huxley's Memoir 'On Dolicholum and Appendicularia,' in "Philos. Transact.," 1851. also the Art. *Tunicata* in the "Cyclopædia of Anatomy and Physiology."

CHAPTER XIV.

MOLLUSCOUS ANIMALS GENERALLY.

THE various forms of 'Shell-fish,' with their 'naked' or shell-less allies, furnish a great abundance of objects of interest to the Microscopist; of which, however, the greater part may be grouped under three heads;—namely, (1) the structure of the *Shell*, which is most interesting in the *Conchifera* or 'Bivalves;' (2) the structure of the *Tongue* of the *Gasteropoda*, most of which have 'Univalve' shells, others, however, being 'naked;' and (3) the *Developmental History* of the embryo, for the study of which certain of the *Gasteropods* present the greatest facilities.—These three subjects, therefore, will be first treated of systematically; and a few miscellaneous facts of interest will be subjoined.

336. *Shells of Mollusca*—These investments were formerly regarded as mere inorganic exudations, composed of calcareous particles cemented together by animal glue; Microscopic examination, however, has shown that they possess a distinctly organic structure; and this structure presents certain very remarkable variations, in some of the natural groups of which the Molluscous series is composed. We shall first describe that which may be regarded as the characteristic structure of the ordinary Bivalves; taking as a type the group of *Margaritacea*, which includes the 'Pearl-oyster' and its allies, the common *Pinna* ranking amongst the latter. In all these shells, we readily distinguish the existence of two distinct layers; an external, of a brownish-yellow colour; and an internal, which has a pearly or 'nacreous' aspect, and is commonly of a lighter hue.—The structure of the *outer* layer may be conveniently studied in the shell of *Pinna*, in which it commonly projects beyond the inner, and there often forms laminae sufficiently thin and transparent to exhibit the general nature of its organization without any artificial reduction. If a small portion of such a lamina be examined with a low magnifying power, even without any preparation by transmitted light, each of its surfaces will present very much the appear-

ance of a honeycomb; whilst its broken edge exhibits an aspect which is evidently fibrous to the eye, but which, when examined under the microscope with reflected light, resembles that of an assemblage of basaltic columns (Fig. 334, *p*). The shell is thus seen to be composed of a vast number of prisms,

FIG. 251.

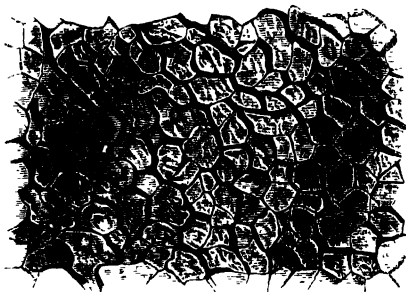

FIG. 252.

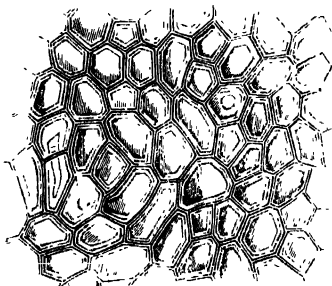

Fig. 251. Section of Shell of *Pinna*, transversely to the direction of its prisms.

Fig. 252. Membranous basis of the same.

separated by definite and strongly-marked lines of division. When such a lamina is submitted to the action of dilute acid, so as to dissolve-away the carbonate of lime, a tolerably firm and consistent membrane is left, which exhibits the prismatic structure just as perfectly as did the original shell (Fig. 252); the hexagonal divisions being apparently the walls of cells

having a tolerably-uniform size, and usually presenting an approach to the hexagonal shape. These are arranged perpendicularly (or nearly so) to the surface of the lamina of the shell; so that its thickness is formed by their length, and its two surfaces by their extremities.

A more satisfactory view of these prisms is obtained by grinding-down a lamina until it possesses a high degree of transparency; and it is then seen (Fig. 251) that the prisms themselves appear to be composed of a very homogeneous substance, but that they are

resembling those of the pith or bark of a plant, in which the cells are frequently hexagonal prisms. In very thin natural laminae, the nuclei of the cells can often be plainly distinguished.

By making a section of the shell perpendicularly to its surface, we obtain a view of the prisms cut in the direction of their length (Fig. 253); and they are frequently seen to be marked by delicate transverse striae (Fig. 251), closely resembling those observable on the prisms

FIG. 253.

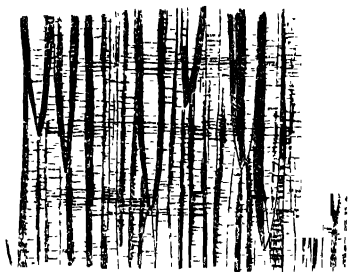

Section of the Shell of *Pinna*, in the direction of its prisms.

of the enamel of teeth, to which this kind of shell-structure may be considered as bearing a very close resemblance,

FIG. 254.

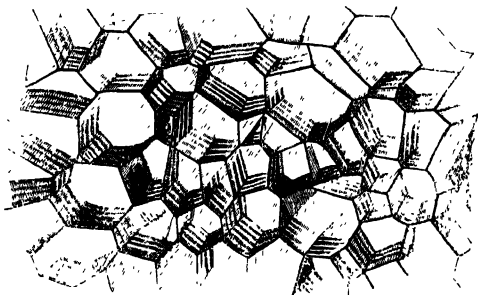

Oblique Section of Prismatic Shell-substance.

except as regards the mineralizing ingredient. If a similar section be decalcified by dilute acid, the membranous residuum will exhibit the walls of the prismatic cells viewed longitudinally; and these will be seen to be more or less regularly marked by the transverse striae just alluded-to.

It sometimes happens in recent, but still more commonly in fossil shells, that the decay of the animal membrane leaves the contained prisms without any connecting medium; as they are then quite isolated, they can be readily detached one from another; and each one may be observed to be marked by the like striations, which, when a sufficiently high magnifying power is used, are seen to be minute grooves, apparently resulting from a thickening of the intermediate wall in those situations. This thickening seems best accounted-for, by supposing (as first suggested by Prof. Owen) that each long prismatic cell is made up by the coalescence of a pile of flat epidermic cells, the transverse striation marking their lines of junction; and this view corresponds well with the fact, that the shell-membrane not unfrequently shows a tendency to split into thin laminae along the lines of striation; whilst we occasionally meet with an excessively thin natural lamina, composed of flat pavement-like cells, lying between the thicker prismatic layers, with one of which it would have probably coalesced, but for some accidental cause which preserved its distinctness. That the prism is not formed in its entire length at once, but that it is progressively lengthened and consolidated at its lower extremity, would appear also from the fact, that where the shell presents a deep colour (as in *Pinna nigra*), this colour is usually disposed in distinct strata, the outer portion of each layer being the part most deeply tinged, whilst the inner extremities of the prisms are almost colourless.—This prismatic arrangement of the carbonate of lime in the shells of *Pinna* and its allies, has been long familiar to conchologists: but it has been usually regarded as the result of crystallisation.

337. It is only in the shells of a few families of Bivalves, that the combination of organic with mineral components is seen in this very distinct form; and these families are for the most part nearly allied to *Pinna*. In all the genera of the *Margaritaceæ*, we find the external layer of the shell formed upon this plan, and of considerable thickness; the internal layer being nacreous. In the *Unionidæ* (fresh-water Mussels), on the contrary, nearly the whole thickness of the shell is made up of the internal or nacreous layer; but a uniform stratum of prismatic cellular substance is always found between the naere and the periostracum.* In the *Ostraceæ* (or Oyster tribe), the greater part of the shell is composed of a sub-nacreous sub-

* The periostracum is the yellowish-brown membrane covering the surface of many shells, which is often (but erroneously) termed the epidermis.

stance, the successively-formed laminæ of which have very little adhesion to each other; but every one of these laminæ is bordered at its free edge by a layer of the prismatic cellular substance, distinguished by its brownish-yellow colour. In these and some other cases, a distinct organic structure is left after the decalcification of the prismatic layer by dilute acid; and this is most tenacious and substantial, where (as in the *Margaritaceæ*) there is no proper periostracum; as if the horny matter which would have otherwise gone to form this investment, had been diffused as an intercellular substance between the proper cell-walls. Generally speaking, a cellular layer may be detected upon the external surface of bivalve shells, where this has been protected by a periostracum, or has been prevented in any other manner from undergoing abrasion; thus it is found pretty generally in *Chama*, *Trigonia*, and *Solen*, and occasionally in *Anomia* and *Pecten*.

338. In many other instances, however, although a cellular arrangement is apparent in sections of the shell, no corresponding structure can be distinctly seen in the delicate membrane left after decalcification. In all such cases, the animal basis bears but a very small proportion to the calcareous deposit, and the shell is usually extremely hard. But there are numerous other cases, in which no distinct traces of cellular structure can be detected in the fully-formed shell; and in which it would seem as if the consolidation of the animal basis by calcareous deposit had taken place whilst the former was as yet in the condition of a uniform gelatinous sarcode, before the commencement of any differentiation into cell-wall and cell-contents. A very curious appearance is presented by a section of the large hinge-tooth of *Mya arenaria* (Fig. 255), in which the carbonate of lime seems to be deposited in nodules, not distinctly separated from each

FIG. 255.

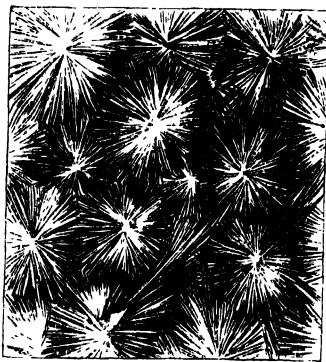
Section of hinge-tooth of *Mya arenaria*.

other by intervening membrane, and possessing a crystalline structure resembling that of the mineral termed Wavellite. Approaches to this curious arrangement are seen in many other shells.

339. The *internal* layer of Bivalve shells rarely presents any distinct structure, when examined in a thin section; and the residuum left after decalcification is usually a structureless 'basement-membrane.' This form of shell-substance may consequently be distinguished as *membranous*. In the *Margaritaceæ* and many other families, this internal layer has a nacreous or iridescent lustre, which depends (as Sir D. Brewster has shown*) upon the striation of its surface with a series of grooved lines, which usually run nearly parallel to each other (Fig. 256). As these lines are not obliterated by any amount

FIG. 256

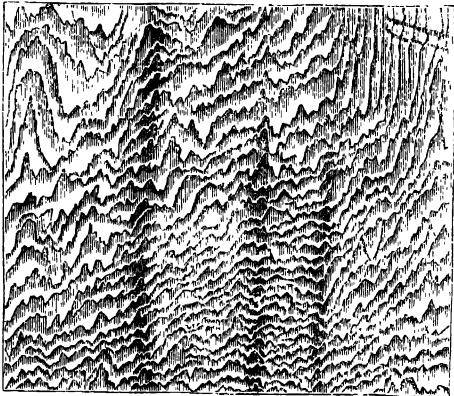
Section of Nacreous lining of shell of *Aracula margaritacea* (Pearl-oyster.)

of polishing, it is obvious that their presence depends upon something peculiar in the texture of this substance, and not upon any mere superficial arrangement. When a piece of naire is carefully examined, it becomes evident that the lines are produced by the cropping-out of laminae of shell, situated more or less obliquely to the plane of the surface. The greater

* "Philos. Transact.," 1814.

the *dip* of these laminae, the closer will their edges be; whilst the less the angle which they make with the surface, the wider will be the interval between the lines. When the section passes for any distance in the plane of a lamina, no lines will present themselves on that space. And thus the appearance of a section of nacre is such, as to have been aptly compared by Sir J. Herschel* to the surface of a smoothed deal board, in which the woody layers are cut perpendicularly to their surface in one part, and nearly in their plane in another. Sir D. Brewster (*loc. cit.*) appears to suppose that nacre consists of a multitude of layers of carbonate of lime alternating with animal membrane; and that the presence of the grooved lines on the most highly-polished surface, is due to the wearing-away of the edges of the animal laminae, whilst those of the hard calcareous laminae stand out. If each line upon the nacreous surface, however, indicates a distinct layer of shell-substance, a very thin section of mother-of-pearl ought to contain many thousand laminae, in accordance with the number of lines upon its surface; these being frequently no more than 1-7500th of an inch apart. But when the nacre is treated with dilute acid, so as to dissolve its calcareous portion, no such repetition of membranous layers is to be found: on the contrary, if the piece of nacre be the product of one act of shell-formation, there is but a single layer of membrane. The membrane is usually found to present a more or less *folded* or *plated* arrangement; but this has generally been obviously disturbed by the disengagement of carbonic acid in the act of decalcification, which tends to unfold the plaits. There is one shell, however,—the well-known *Haliothis splendens*,—which affords us the opportunity of examining the plaits without any disturbance of their arrangement, and thus presents a clear demonstration of the real structure of nacre. This shell is for the most part made-up of a series of plates of animal matter, resembling tortoiseshell in its aspect, alternating with thin layers of nacre; and if a piece of it be submitted to the action of dilute acid, the calcareous portion of the nacreous layers being dissolved-away, the plates of animal matter fall-apart, each one carrying with it the membranous residuum of the layer of nacre that was applied to its inner surface. It will usually be found that the nacre-membrane covering some of these horny plates will remain in an undisturbed condition; and *their surfaces then exhibit their iridescent lustre, although all the calcareous matter has been removed from*

* "Edinb. Philos. Journal," vol. ii.

their structure. On looking at the surface with reflected light under a magnifying power of 75 diameters, it is seen to present a series of folds or plaits more or less regular; and the iridescent hues which these exhibit, are often of the most gorgeous description. If the membrane be extended, however, with a pair of needles, these plaits are unfolded, and it covers a much larger surface than before; but its iridescence is then completely destroyed. This experiment, then, demonstrates that the peculiar lineation of the surface of nacre (on which its iridescence undoubtedly depends, as originally shown by Sir D. Brewster) is due, not to the outcropping of alternate layers of membranous and calcareous matter, but to the disposition of a single membranous layer in folds or plaits, which lie more or less obliquely to the general surface.—There are several bivalve shells which present what may be termed a *sub-nacreous* structure, their polished surfaces being covered with lines indicative of folds in the basement-membrane; but these folds are destitute of that regularity of arrangement, which is necessary to produce the iridescent lustre. This is the case, for example, with most of the *Pectinidæ* (or Scallop tribe), also with some of the *Mytilaceæ* (or Mussel tribe), and with the common *Oyster*. Where there is no indication of a regular corrugation of the shell-membrane, there is not the least approach to the nacreous aspect; and this is the case with the internal layer of by far the greater number of shells, the presence of true nacre being exceptional, save in a small number of families.—It is of the inner layer that those rounded concretions are usually formed, which are often found in the interior of shells, and which, when composed of nacreous substance resembling that of the lining of the shell of *Avicula*, are known as *pearls*. Such concretions are found in many other shells; but they are usually less remarkable for their pearly lustre; and when formed at the edge of the valves, they may be partly or even entirely made-up of the prismatic substance of the external layer, and may be consequently altogether destitute of the pearly aspect.—The ‘membranous’ shell-substance, some form of which constitutes the internal layer of most bivalve shells, is occasionally traversed by *tubes*, which seem to commence from the inner surface of the shell, and to pass towards the exterior. These tubes vary in size from about the 1-20,000th of an inch, or even less, to about the 1-2000th; but their general diameter, in the shells in which they most abound, is about 1-4000th of an inch. The direction and distribution of these tubes are extremely various in

different genera: in *Anomia ephippium* they are scantily distributed in the internal nacreous lamina, whilst in the yellow outer layer they are very abundant, forming an irregular net-work (Fig. 257), which spreads-out in a plane parallel to the surface.

FIG. 257.

Tubular Shell-structure of *Anomia*.

340. The ordinary account of the mode of growth of the shells of Bivalve Mollusca,—that they are progressively enlarged by the deposition of new laminae, each of which is in contact with the internal surface of the preceding, and extends beyond it,—does not express the whole truth; for it takes no account of the fact that most shells are composed of two layers of very different texture, and does not specify whether *both* these layers are thus formed by the entire surface of the mantle whenever the shell has to be extended, or whether *one* is produced. An examination of Fig. 258 will

FIG 258.

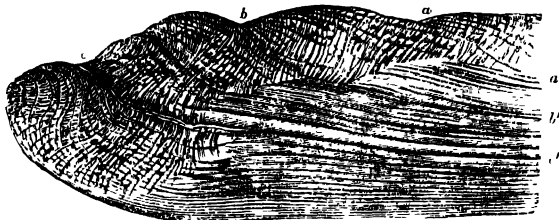

Vertical section of the lip of one of the valves of the shell of *Unio*:—
a, b, c, successive formations of the outer layer; *a', b', c'*, the same of
 the inner layer.

clearly show the mode in which the operation is effected. This figure represents a section of one of the valves of *Unio occidens*, taken perpendicularly to its surface, and passing

from the margin or lip (at the left hand of the figure) towards the hinge (which would be at some distance beyond the right). This section brings into view the two substances of which the shell is composed; traversing the outer or prismatic layer in the direction of the length of its cells, and passing through the nacreous lining, in such a manner as to bring into view its numerous laminae, separated by the lines $a a'$, $b b'$, $c c'$, &c. These lines evidently indicate the successive formations of this layer; and it may be easily shown, by tracing them towards the hinge on the one side, and towards the margin on the other, that at every enlargement of the shell, its whole interior is lined by a new nacreous lamina, in immediate contact with that which preceded it. The number of such laminae, therefore, in the oldest part of the shell, indicates the number of enlargements which it has undergone. The outer or prismatic layer of the growing shell, on the other hand, is only formed where the new structure projects beyond the margin of the old; and thus we do not find one layer of it overlapping another, except at the lines of junction of two distinct formations. When the shell has attained its full dimensions, however, new laminae of both layers still continue to be added; and thus the lip becomes thickened by successive formations of prismatic structure, each being applied to the inner surface of the preceding, instead of to its free margin. A like arrangement may be well seen in the *Oyster*; with this difference, that the successive layers have but a comparatively slight adhesion to each other.

341. The shells of *Terebratulæ*, and of several other genera of *Brachiopoda*, are distinguished by peculiarities of structure, which serve to distinguish them from all others. When thin sections of them are microscopically examined, they exhibit the appearance of long flattened prisms (Fig. 259, *b*), which are arranged with such obliquity, that their rounded extremities crop-out upon the inner surface of the shell in an imbricated (tile-like) manner (*a*). All true *Terebratulidæ*, both recent and fossil, exhibit another very remarkable peculiarity; namely, the presence of a large number of *perforations* in the shell, generally passing nearly perpendicularly from one surface to the other (as is shown in vertical sections, Fig. 261), and terminating internally by open orifices (Fig. 259), whilst externally they are covered by the periostracum (Fig. 260). Their diameter is greatest towards the external surface, where they sometimes expand suddenly, so as to become trumpet-shaped;

and it is usually narrowed rather suddenly, when, as sometimes happens, a new internal layer is formed as a lining to

FIG. 259.

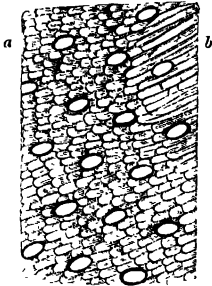

FIG. 260.

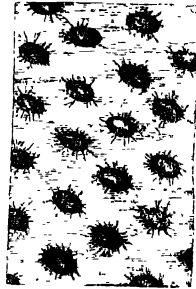

FIG. 259. Internal surface (a), and oblique section (b), of Shell of *Terebratula* (*Waldheimia*) *australis*.

FIG. 260. External surface of the same.

the preceding (Fig. 261, A, *dd*). Hence the diameter of these canals, as shown in different transverse sections of one and the same shell, will vary according to

the part of its thickness which the section happens to traverse. The different species of *Terebratulidæ*, however, present very striking diversities in the size and closeness of the canals, as shown by sections taken in corresponding parts of their shells; three examples of this kind are given for the sake of comparison in Figs 262-264. These canals are occupied, in the living

FIG. 261.

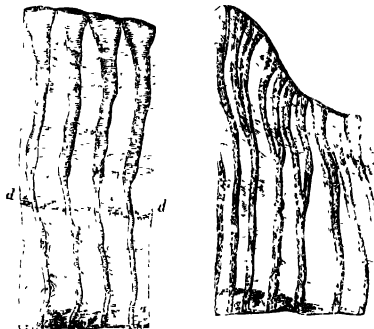

Vertical sections of Shell of *Terebratula* (*Waldheimia*) *australis*:—showing at A the canals opening by large trumpet-shaped orifices on the outer surface, and contracting at *dd* into narrow tubes; and presenting at B a bifurcation of the canals.

state, by tubular prolongations of the mantle, the interior of which is filled with a fluid containing minute cells and

FIG. 262.



FIG. 26

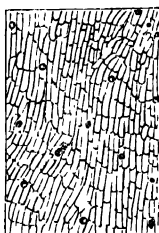

FIG. 264.

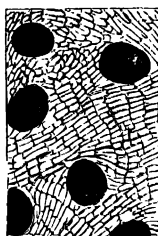

FIG. 262. Horizontal section of Shell of *Terebratula bullata* (fossil, oolite).
 FIG. 263. Ditto, : : : : of *Megerlia lima* (fossil, chalk).
 FIG. 264. Ditto, of *Spiriferina rostrata* (triassic).

granules, which, from its corresponding in appearance with the fluid contained in the great sinuses of the mantle, may be considered to be the animal's blood. Hence these caecal tubes may be inferred to possess a respiratory function; and seem to be analogous to tubes of a very similar nature, which extend into the 'test' of many Tunicata from their sinus-system (§ 334).—In the family *Rhynchonellidæ*, which is represented by only two recent species (the *Rh. psittucea* and *Rh. nigricans*, both of which formerly ranked as *Terebratulæ*), but which contains a very large proportion of fossil Brachiopods, these canals are entirely absent; so that the uniformity of their presence in the *Terebratulidæ*, and of their absence in the *Rhynchonellidæ*, supplies a character of great value in the discrimination of the fossil shells belonging to these two groups respectively. Great caution is necessary, however, in applying this test; mere surface-markings cannot be relied-on; and no statement on this point is worthy of reliance, which is not based on a microscopic examination of thin sections of the shell.—In the families *Spiriferidæ* and *Strophonemidæ*, on the other hand, some species possess the perforations, whilst others are destitute of them; so that their presence or absence *there* only serves to mark-out subordinate groups. This, however, is what holds-good in regard to characters of almost every description, in other departments of Natural History, as well as in this; a character which is of fundamental importance

from its close relation to the general plan of organisation in one group, being, from its want of constancy, of far less account in another.*

342. There is not by any means the same amount of diversity in the structure of the shell in the class of *Gastropoda*, as that which exists among the several tribes of *Conchifera*; a certain typical plan of construction being common to by far the greater number of them. The small proportion of animal matter contained in most of these shells, is a very marked feature in their character; and it serves to render other features indistinct, since the residuum left after the removal of the calcareous matter is usually so imperfect, as to give no clue whatever to the explanation of the appearances shown by sections. Nevertheless, the structure of these shells is by no means homogeneous, but always exhibits indications, more or less clear, of an original organic arrangement. The 'porcellaneous' shells are composed of three layers, all presenting the same kind of structure, but each differing from the others in the mode in which this is disposed. For each layer is made-up of an assemblage of thin laminae placed side by side, which separate one from another, apparently in the planes of rhomboidal cleavage, when the shell is fractured; and, as was first pointed-out by Mr. Bowerbank, each of these laminae consists of a series of elongated spicules (considered by him as prismatic cells filled with carbonate of lime) lying side by side in close apposition; and these series are disposed alternately in contrary directions, so as to intersect each other nearly at right angles, though still lying in parallel planes. The direction of the planes is different, however, in the three layers of the shell, bearing the same relation to each other as have those three sides of a cube which meet each other at the same angle; and by this arrangement, which is better seen in the fractured edge of *Cypraea* or any similar shell, than in thin sections, the strength of the shell is greatly augmented. A similar arrangement, obviously designed with the same purpose, has been shown by Mr. Tomes to exist in the enamel of the teeth of Rodentia.—The principal departures from this plan of structure are seen in *Patella*, *Chiton*, *Haliotis*, *Turbo* and its allies, and in the 'naked' *Gastropods*, many of which last, both terrestrial and marine, have some

* For a particular account of the Author's researches on this group, see his memoir on the subject, forming part of the Introduction of Mr. Davidson's "Monograph of the British Fossil Brachiopoda," published by the Palaeontographical Society.

rudiment of a shell. Thus in the common Slug, *Limax rufus*, a thin oval plate, of calcareous texture, is found imbedded in the shield-like fold of the mantle covering the fore-part of its back; and if this be examined in an early stage of its growth, it is found to consist of an aggregation of cell-like bodies, generally somewhat hexagonal in form, and consolidated by a deposit of calcareous matter, which is sometimes so arranged as to be quite transparent, whilst in other instances it presents an appearance closely resembling that delineated in Fig. 255. —In the epidermis of the mantle of some species of *Doris*, on the other hand, we find long calcareous spicules, generally lying in parallel directions, but not in contact with each other, giving firmness to the whole of its dorsal portion; and these are sometimes covered with small tubercles, like the spicules of *Gorgonia* (§ 309). They may be separated from the soft tissue in which they are imbedded, by means of caustic potash; and when treated with dilute acid, whereby the calcareous matter is dissolved-away, an organic basis is left, retaining in some degree the form of the original spicule. This basis cannot be said to be a true cell; but it seems to be rather a cell in the earliest stage of its formation, being an isolated particle of 'sarcode' without wall or cavity; and the close correspondence between the appearances presented by thin sections of various 'univalve' shells, and the forms of the spicules of *Doris*, seems to justify the conclusion, that even the most compact shells of this group are constructed out of the like elements, in a state of closer aggregation and more definite arrangement, with the occasional occurrence of a layer of more spheroidal bodies of the same kind, like those forming the rudimentary shell of *Limax*.

343. The animals composing the class of *Cephalopoda* (Cuttle-fish and Nautilus tribe), are for the most part unpossessed of shells; and the structure of the few that we meet-with in the genera *Nautilus*, *Argonauta* (Paper-nautilus) and *Spirula*, does not present any peculiarities that need here detain us. The rudimentary shell or *sepiostere* of the common Cuttle-fish, however, which is frequently spoken-of as the 'cuttle-fish bone,' exhibits a very beautiful and remarkable structure, such as causes sections of it to be very interesting microscopic objects. The outer shelly portion of this body consists of horny layers, alternating with calcified layers, in which last may be seen a hexagonal arrangement somewhat corresponding with that in Fig. 255. The soft friable substance that occupies the hollow of this boat-shaped shell, is

formed of a number of delicate plates, running across it from one side to the other in parallel directions, but separated by intervals several times wider than the thickness of the plates; and these intervals are in great part filled-up by what appear to be fibres or slender pillars, passing from one plate or floor to another. A more careful examination shows, however, that instead of a large number of detached pillars, there exists a comparatively small number of very thin sinuous laminae, which pass from one surface to the other, winding and doubling upon themselves, so that each lamina occupies a considerable space. Their precise arrangement is best seen by examining the parallel plates, after the sinuous laminae have been detached from them; the lines of junction being distinctly indicated upon these. By this arrangement, each layer is most effectually supported by those with which it is connected above and below; and the sinuosity of the thin intervening laminae, answering exactly the same purpose as the 'corrugation' given to iron plates for the sake of diminishing their flexibility, adds greatly to the strength of this curious texture; which is at the same time lightened by the large amount of space between the parallel plates that intervenes between the sinuosities of the laminae. The best method of examining this structure, is to make sections of it with a sharp knife in various directions, taking care that the sections are no thicker than is requisite for holding-together; and these may be mounted on a black ground as opaque objects, or in Canada balsam as transparent objects.

344. The structure of Shells generally is best examined by making sections in different planes, as nearly parallel as may be possible to the surfaces of the shell; and other sections at right angles to these: the former may be designated as *horizontal*, the latter as *vertical*. Nothing need here be added to the full directions for making such sections, which have already been given (§§ 108-110). Much valuable information may also be derived, however, from the examination of the surfaces presented by fracture. The membranous residua left after the decalcification of the shell by dilute acid, may be mounted in weak spirit or in Goadby's solution.*

345. *Tongue of Gasteropod Mollusks.*—The organ which is

* For fuller details on the minute structure of the shells of the Mollusca, see the Author's memoirs on that subject in the "Reports of the British Association" for 1844 and 1847; also Mr. Bowerbank's memoir on the same subject in "Transact. of Microsc. Society." Ser. 1, vol. i.; and Mr. Quekett's "Lectures on Histology," vol. ii., chaps. xvi.—xxii.

commonly known under this designation, is one of a very singular nature; and we should be altogether wrong in conceiving of it as having any likeness to that on which our ordinary ideas of such an organ are founded. For instead of being a projecting body, lying in the cavity of the mouth, it is a tube that passes backwards and downwards beneath the mouth; its hinder end being closed, whilst in front it opens obliquely upon the floor of the mouth, being (as it were) slit-up and spread-out, so as to form a nearly flat surface.

FIG. 265.

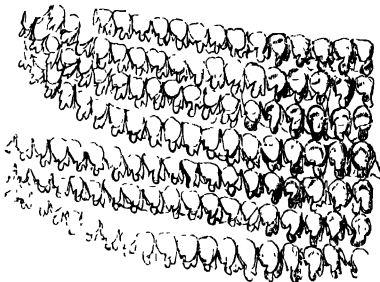

Portion of the left half of the Palate of *Helix hortensis*; the rows of teeth near the edge separated from each other to show their form.

FIG. 266.

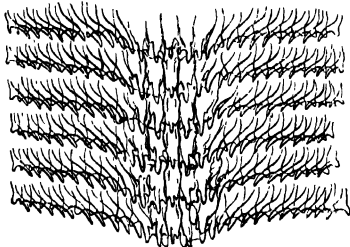

Palate of *Zonites cellarius*.

On the interior of the tube, as well as on the flat expansion of it, we find numerous transverse rows of minute teeth, which are set upon flattened plates; each principal tooth sometimes having a basal plate of its own, whilst in other instances one plate carries several teeth. Of the former arrangement we have an example in the tongue of many terrestrial Gasteropods, such as the Snail (*Helix*) and Slug (*Limax*), in which the number of plates in each row is very considerable (Figs. 265, 266), amounting to 180 in the large garden Slug (*Limax maximus*); whilst the latter prevails in many marine Gasteropods, such as the common Whelk (*Buccinum undatum*),

the tongue of which has only three plates in each row, one bearing the small central teeth, and the two others the large lateral teeth (Fig. 269). The length of the tongue, and the number of rows of teeth, vary greatly in different species. Generally speaking, the tongue of the terrestrial Gasteropods is short, and is contained entirely within the nearly-globular head; but the rows of teeth being closely set-together, they are usually very numerous, there being frequently more than 100, and in some species as many as 160 or 170; so that the total number of teeth may mount-up, as in *Helix pomatia*, to 21,000, and in *Limax maximus*, to 26,800. The transverse rows are usually more or less curved, as shown in Fig. 266, whilst the longitudinal rows are quite straight; and the curvature takes its departure on each side from a central longitudinal row, the teeth of which are symmetrical, whilst those of the lateral portions of each transverse row present a modification of that symmetry, the prominences on the *inner* side of each tooth being suppressed, whilst those on the outer side are increased; this modification being observed to augment in degree, as we pass from the central line towards the edges. The tongue of the marine Gasteropods is generally longer, and its teeth larger; and in many instances it extends far beyond the head, which may, indeed, contain but a small part of it. Thus in the common Limpet (*Patella*), we find the principal part of the tongue to lie folded-up, but perfectly free, in the abdominal cavity, between the intestines and the muscular foot; and in some species its length is twice or even three times as great as that of the entire animal. In a large proportion of cases, these tongues exhibit a very marked separation between the central and the lateral portions (Figs. 267, 269); the teeth of the central band being frequently small and smooth at their edges, whilst those of the lateral are large and serrated. The tongue of *Trochus zizyphius*, represented in Fig. 267, is one of the most beautiful examples of this form; not only the large teeth of the lateral bands, but the delicate leaf-like teeth of the central portion, having their edges minutely serrated. A yet more complex type, however, is found in the tongue of *Haliotis*; in which there is a central band of teeth having nearly straight edges instead of points; then, on each side, a lateral band consisting of large teeth shaped like those of the shark; and beyond this, again, another lateral band on either side, composed of several rows of smaller teeth. Very curious differences also present themselves among the different

species of the same genus. Thus in *Doris pilosa*, the central band is almost entirely wanting, and each lateral band is

FIG 267.

Palate of *Doris pilosa*.

FIG 268.

Palate of *Doris tuberculata*.

formed of a single row of very large hooked teeth, set obliquely, like those of the lateral bands in Fig. 267; whilst in *Doris tuberculata*, the central band is the part most developed, and contains a number of rows of conical teeth, standing almost perpendicularly, like those of a harrow (Fig. 268).

346. Many other varieties might be described, did space permit; but we must be content with adding, that the form and arrangement of the teeth afford characters of great value in classification, as was first pointed-out by Prof. Lovén (of Stockholm) in 1847, and has been since very strongly urged by Dr. J. E. Gray, who considers that the structure of the tongue is one of the best guides to the natural affinities of the species, genera, and families of this

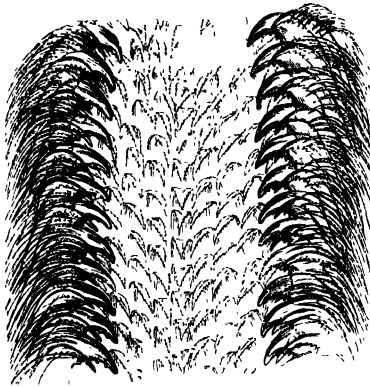
group, since any important alteration in the form or position of the teeth must be accompanied by some corresponding

peculiarity in the habits and manners of the animal.* Hence a systematic examination and delineation of the structure and arrangement of these organs, by the aid of the Microscope and the Camera Lucida, would be of the greatest service to this department of Natural History.—The short thick tube of the *Limax* and other terrestrial Gasteropods, appears adapted for the trituration of the food previously to its passing into the cesophagus; for in these animals we find the roof of the mouth furnished with a large strong horny plate, against which the flat end of the tongue can work. On the other hand, the flattened portion of the tongue of *Buccinum* and its allies is used by these animals as a file, with which they bore holes through the shells of the mollusks that serve as their prey; this they are enabled to effect, by everting that part of the proboscis-shaped mouth whose floor is formed by the flattened part of the tongue, which is thus brought to the exterior, and by giving a kind of sawing-motion to the organ, by means of the alternate action of two pairs of muscles,—a protractor, and a retractor,—which put-forth and draw-back a pair of cartilages whereon the tongue is supported, and also elevate and depress its teeth.† Of the use of the long blind tubular part of the tongue in these Gasteropods, however, scarcely any probable guess can be made; unless it be a sort of ‘cavity of reserve,’ from which a new toothed surface may be continually supplied, as the old one is worn-away, somewhat as the front teeth of the Rodents are constantly being regenerated from the surface of the pulps which occupy their hollow conical bases, as fast as they are rubbed-down at their edges.

347. The preparation of these tongues for the Microscope, can, of course, be only accomplished by carefully dissecting them from their attachments within the head; and it will be also necessary to remove the membrane that forms the sheath of the tube, when this is thick enough to interfere with its transparency. The tube itself should be slit-up with a pair of fine scissors, through its entire length; and should be so opened-out, that its expanded surface may be a continuation of that which forms the floor of the mouth. The mode of mounting it will depend upon the manner in which it is to be viewed. For the ordinary purposes of Microscopic examina-

* “Annals of Natural History,” Ser. 2, vol. x., p. 413.

† For additional details on the organization of the tongue and teeth of the Gasteropod Mollusks, see Mr. W. Thomson, in “Cyclop. of Anat. and Physiol.,” vol. iv., pp. 1142, 1143, and in “Ann. of Nat. Hist.,” Ser. 2, vol. vii., p. 86.

tion, no method is so good as mounting in fluid; either weak spirit or Goadby's solution answering very well. But many of these tongues, especially those of the marine Gasteropods, become most beautiful objects for the Polariscope, when they are mounted in Canada balsam; the form and arrangement of

FIG. 269.

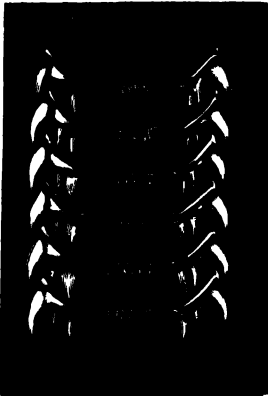

Palate of *Buccinum undatum*, as seen under polarized light.

the teeth being very strongly brought-out by it (Fig. 269), and a gorgeous play of colours being exhibited when a selenite plate is placed behind the object, and the analysing prism is made to rotate.

348. The stomachs, also, of many Gasteropod Mollusks are furnished with teeth, which are implanted on their walls for the further reduction of the food; such teeth, very numerous but of small size, and bearing a strong resemblance to those of its tongue, are found in the stomach of the common *Slug*. In several marine Gasteropods, however, especially *Bulla*, *Scyllæa*, and *Aplysia*, the gastric teeth are individually much larger, though less numerous, and constitute a very efficient

reducing apparatus, especially when combined, as they frequently are, with a horny or calcareous deposit in the walls of the stomach, which converts it into a 'gizzard' for the trituration of the substances that have been divided by the teeth.

349. *Development of Gasteropod Mollusks.*—The history of embryonic development may be studied with peculiar facility in certain members of this class, and presents numerous phenomena of great interest. The eggs (save among the terrestrial species) are usually deposited in aggregate masses, each enclosed in a common protective envelope. The nature of this envelope, however, varies greatly: thus in the common *Gymnæus stagnalis*, or 'water-snail,' of our ponds and ditches, it is nothing else than a mass of soft jelly, about the size of a sixpence, in which from 50 to 60 eggs are imbedded, and which is attached to the leaves or stems of aquatic plants; in the

Buccinum undatum, or common Whelk, it is a membranous case, connected with a considerable number of similar cases by short stalks, so as to form large globular masses, which may often be picked-up on our shores, especially between April and June; in the *Purpura lapillus*, or Rock-whelk, it is a little flask-shaped capsule, having a firm horny wall, which is attached by a sort of foot to the surface of rocks between the tide-marks, great numbers being often thus found standing erect side by side; whilst in the *Nudibranchiate* order generally (consisting of the *Doris*, *Eolis*, and other 'sea-slugs') it forms a long tube with a membranous wall, in which immense numbers of eggs (even half a million or more) are packed closely together in the midst of a jelly-like substance, this tube being disposed in coils of various forms, which are usually attached to sea-weeds or zoophytes.—The course of development, in the first and last of these instances, may be readily observed from the very earliest period, down to that of the emersion of the embryo; owing to the extreme transparency of the 'nidamentum,' and of the egg-membranes themselves. The first change which will be noticed by the ordinary observer, is the 'segmentation' of the yolk-mass, which divides itself (after the manner of a cell undergoing duplicative subdivision) into two parts, each of these two into two others, and so on, until a mulberry-like mass of minute yolk-segments is evolved. Generally speaking, however, there may be noticed at a very early stage of this process, as performed by Gasteropod Mollusks, an inequality in the size of the segments (Fig. 271, c); one set, derived from the larger of the two divisions (d) into which the yolk-sphere first separates itself, being destined to form the internal organs, whilst the other set of segments, of much inferior dimensions, and formed by the subdivision of the smaller half of the original sphere, furnishes the material for the superficial parts. Soon after the 'mulberry mass' has been formed, it commonly begins to exhibit a very curious alternating movement within the egg, two or three turns being made in one direction, and the same number in a reverse direction: this movement, which is due to ciliary action, is often extremely transitory in its duration; but in the *Lymnæus* it continues almost up to the escape of the embryo, and, when several ova are brought into view at once under a low magnifying power, the spectacle is a very curious one.

350. A separation is usually seen at an early period, between the anterior or cephalic portion, and the posterior or visceral

portion, of the embryonic mass; and the development of the former advances with the greater activity. One of the first changes which is seen in it, consists in its extension into a sort of fin-like membrane on either side, the edges of which are fringed with long cilia (Fig. 270), whose movements may be clearly distinguished whilst the embryo is still shut-up within the egg; at a very early period may also be discerned the 'auditory vesicles' or rudimentary organs of hearing (§ 353), which scarcely attain any higher development in these creatures during the whole of life; and from the immediate neighbourhood of these is put-forth a projection, which is afterwards

FIG. 270.

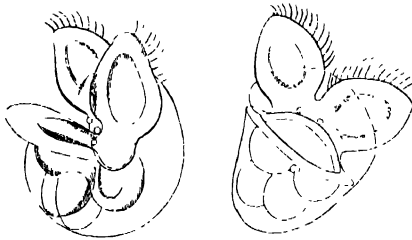
Embryoes of *Nudibranchiate Gastropods*.

to be evolved into the 'foot' or muscular disk of the animal. While these organs are making their appearance, the shell is being formed on the surface of the posterior portion, appearing first as a thin covering over its hinder part, and gradually extending itself until it becomes large enough to enclose the embryo completely, when this contracts itself. The ciliated lobes are best seen in the embryos of *Nudibranchs*, in which they are much larger than in *Lymnaeus*; and the fact of the universal presence of a shell in the embryos of the former group, is of peculiar interest, as it is destined to be cast-off very soon after they enter upon active life. These embryos may be seen to move-about as freely as the narrowness of their prison permits, for some time previous to their emersion; and when set-free by the rupture of the egg-cases, they swim-forth with great activity by the action of their ciliated lobes,—these,

like the wheels of Rotifera, serving also to bring food to the mouth, which is at that time unprovided with the reducing apparatus subsequently found in it. The same is true of the embryo of *Lymnaeus*, save that its swimming movements are less active, in consequence of the inferior development of the ciliated lobes; and the currents produced by these seem to have reference chiefly to the provision of supplies of food, and of aerated water for respiration. The disappearance of the cilia has been observed by Mr. Hogg to be coincident with the development of the teeth to a degree sufficient to enable the young water-snail to crop its vegetable food; and he has further ascertained, that if the growing animal be kept in fresh water alone for some time, without vegetable matter of any kind, the gastric teeth are very imperfectly developed, and the cilia are still retained.*

351. A very curious modification of the ordinary plan of development, is presented in the *Purpura lapillus*; and it is probable that something of the same kind exists also in *Buccinum*, as also in other Gasteropods of the same extensive order (*Pectinibranchiata*).—Each of the capsules already described (§ 349) contains

from 500 to 600 egg-like bodies (Fig. 271, A), imbedded in a viscid gelatinous substance; but only from 12 to 30 embryos usually attain complete development; and it is obvious from the large comparative size which these attain (Fig. 272, B), that each of them must include an amount of substance equal to that of a great number of the bodies originally found within the capsule. The explanation of this fact

(long since noticed by Dr. J. E. Gray in regard to *Buccinum*) seems to be as follows:—Of those 500 or 600 egg-

FIG. 271

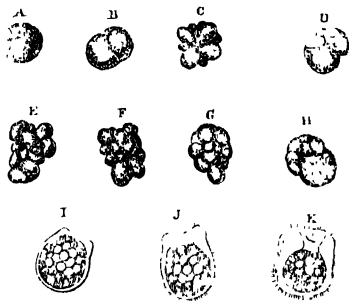

Early stages of embryonic development of *Purpura lapillus* - - A, egg-like spherule; B, C, E, F, G, successive stages of segmentation of yolk-spherules; D, H, I, J, K, successive stages of development of early embryos.

* See "Transact. of Microsc. Soc." 2nd Ser., vol. ii., p. 93.

like bodies, only a small part are true *ova*, the remainder being merely *yolk-spherules*, which are destined to serve for the nutrition of the embryos. The distinction between them manifests itself at a very early period, even in the first segmentation; for while the yolk-spherules divide into two equal hemispheres (Fig. 271, B), the real ova divide into a larger and a smaller segment (p); in the cleft between these are seen the minute 'directive vesicles,' which appear to be always double or even triple, although, from being seen 'end-on,' only one may be visible; and near these is generally to be seen a clear space in each segment. The difference is still more strongly marked in the subsequent divisions; for whilst the cleavage of the yolk-spherules goes on irregularly, so as to divide each into from 14 to 20 segments having no definiteness of arrangement (C, E, F, G), that of the ova takes place in such a manner as to mark-out the distinction already alluded-to between the cephalic and the visceral portions of the mass (H); and the evolution of the former into distinct organs very speedily commences. In the first instance, a narrow transparent border is seen around the whole embryonic mass, which is broader at the cephalic portion (I); next, this border is fringed with short cilia, and the cephalic extension into two lobes begins to show itself; and then between the lobes a large mouth is formed, opening through a short, wide œsophagus, the interior of which is ciliated, into the visceral cavity, occupied as yet only by the yolk-particles originally belonging to the ovum (κ).—Whilst these developmental changes are taking place in the embryo, the whole aggregate of segments formed by the subdivision of the yolk-spherules coalesces into one mass, as shown at A, Fig. 272; and the embryos are often, in the first instance, so completely buried within this, as only to be discoverable by tearing its portions asunder; but some of them may commonly be found upon its exterior; and those contained in one capsule very commonly exhibit the different stages of development represented in Fig. 271, H—κ. After a short time, however, it becomes apparent that the most advanced embryos are beginning to swallow the yolk-segments of the conglomerate mass; and capsules will not unfrequently be met-with, in which embryos of various sizes, as *a, b, c, d, e* (Fig. 272, A), are projecting from its surface, their difference of size not being accompanied by advance in development, but merely depending upon the amount of this 'supplemental' yolk which the individuals have respectively gulped-down. For during the time in which they

are engaged in appropriating this additional supply of nutriment, although they increase in size, yet they scarcely exhibit

FIG. 272.



Later stages of embryonic development of *Purpura lapillus*.—A, conglomerate mass of vitelline segments, to which were attached the embryos, *a, b, c, d, e*.—B, full-sized embryo, in more advanced stage of development.

any other change; so that the large embryo, Fig. 272, *e*, is not apparently more advanced as regards the formation of its organs, than the small embryo, Fig. 271, *k*. So soon as this operation has been completed, however, and the embryo has attained its full bulk, the evolution of its organs takes place very rapidly; the ciliated lobes are much more highly developed, being extended in a long sinuous margin, so as almost to remind the observer of the 'wheels' of Rotifera (§ 277), and being furnished with very long cilia (Fig. 272, B); the auditory vesicles, the tentacula, the eyes, and the foot, successively make their appearance; a curious rhythmically-contractile vesicle is seen, just beneath the edge of the shell in the region of the neck, which may, perhaps, serve as a temporary heart; a little later, the real heart may be seen pulsating beneath the dorsal part of the shell; and the mass of yolk-segments of which the body is made-up, gradually shapes itself into the various organs of digestion, respiration, &c., during the evolution of which (and while they are as yet

far from complete) the capsule thins-away at its summit, and the embryos make their escape from it.

352. It happens not unfrequently, that one of the embryos which a capsule contains, does not acquire its supplemental yolk in the manner now described, and can only proceed in its development as far as its original yolk will afford it material; and thus, at the time when the other embryos have attained their full size and maturity, a strange-looking creature, consisting of two large ciliated lobes with scarcely the rudiment of a body, may be seen in active motion among them. This may happen, indeed, not only to one but to several embryos within the same capsule, especially if their number should be considerable; for it sometimes appears as if there were not food enough for all, so that whilst some attain their full dimensions and complete development, others remain of unusually small size, without being deficient in any of their organs, and others again are more or less completely abortive,—the supply of supplemental yolk which they have obtained having been too small for the development of their viscera, although it may have afforded what was needed for that of the ciliated lobes, eyes, tentacles, auditory vesicles, and even the foot,—or, on the other hand, no additional supply whatever having been acquired by them, so that their development has been arrested at a still earlier stage.—These phenomena are of so novel and remarkable a character, that they furnish an abundant source of interest to any Microscopist who may happen to be spending the months of August and September in a locality in which the *Purpura* abounds; since, by opening a sufficient number of capsules, no difficulty need be experienced in arriving at all the facts which have been noticed in this brief summary.* It is much to be desired that such Microscopists as possess the requisite opportunity, would apply themselves to the study of the corresponding history in other Pectinibranchiate Gasteropods, with a view of determining how far the plan now described prevails through the order. And now that these Mollusks have been brought not only to live, but to breed, in artificial 'vivaria,' it may be anticipated that a great addition to our knowledge of this part of their life-history will ere long be made.†

* Fuller details on this subject will be found in the Author's account of his researches, in the Second Series of the "Transactions of the Microscopical Society," vol. iii., p. 17: and he would refer such of his readers as may be desirous of knowing what has been done by other observers in regard to the development of different species of Gasteropods, to the various Memoirs there cited.

† The Author thinks it worth while to mention the method which he has found

353. *Ciliary Motion on Gills.*—There is no object that is better suited to exhibit the general phenomena of ciliary motion (§ 276), than a portion of the gill of some ‘bivalve’ Mollusk. The *Oyster* will answer the purpose sufficiently well; but the cilia are much larger on the gills of the *Mussel*,* as they are also on those of the *Anodon* or common ‘fresh-water mussel’ of our ponds and streams. Nothing more is necessary, than to detach a small portion of one of the riband-like bands, which will be seen running parallel with the edge of each of the valves when the shell is opened; and to place this, with a little of the liquor contained within the shell, upon a slip of glass,—taking care to spread it out sufficiently with needles to separate the *bars* of which it is composed, since it is on the edges of these, and round their knobbed extremities, that the ciliary movement presents itself,—and then covering it with a thin-glass-disk. Or it will be convenient to place the object in the animalcule-cage, which will enable the observer to subject it to any degree of pressure that he may find convenient. A magnifying power of about 120 diameters is amply sufficient to afford a general view of this spectacle; but a much greater amplification is needed, to bring into view the peculiar mode in which the stroke of each cilium is made. Few spectacles are more striking to the unprepared mind, than the exhibition of such wonderful activity as will then become apparent, in a body which to all ordinary observation is so inert. This activity serves a double purpose; for it not only drives a continual current of water over the surface of the gills themselves, so as to effect the aeration of the blood, but it also directs a portion of this current (as in the *Tunicata*, § 333) to the mouth, so as to supply the digestive apparatus with the aliment afforded by the *Diatomaceæ*, *Infusoria*, &c., which it carries-in with it.

354. *Organs of Sense of Mollusks.*—Some of the minuter and more rudimentary forms of the special organs of sight, hearing, and touch, which the Molluscous series presents, are very interesting objects of Microscopic examination. Thus

most convenient for examining the contents of the capsules of *Purpura*; as he believes that it may be advantageously adopted in many other cases. This consists in cutting-off the two ends of the capsule (taking care not to cut far into its cavity), and in then forcing a jet of water through it, by inserting the end of a fine-pointed syringe (§ 132) into one of the orifices thus made, so as to drive the contents of the capsule before it through the other. These should be received into a shallow cell, and first examined under the single microscope.

* This shell-fish may be obtained, not merely at the sea-side, but likewise at the shops of the Fishmongers who supply the humbler classes, even in midland towns.

just within the margin of each valve of *Pecten*, we see (when we observe the animal in its living state, under water) a row of minute circular points of great brilliancy, each surrounded by a dark ring; these are the eyes, with which this creature is provided for the purpose (it can scarcely be doubted) of directing its peculiarly-active movements. Each of them, when their structure is carefully examined, is found to be protected by a sclerotic coat with a transparent cornea in front, and to possess a coloured iris (having a pupil) that is continuous with a layer of pigment lining the sclerotic, a crystalline lens and vitreous body, and a retinal expansion proceeding from an optic nerve which passes to each eye from the trunk that runs along the margin of the mantle. Eyes of still higher organization are borne upon the head of most Gasteropod Mollusks, generally at the base of one of the pairs of tentacles, but sometimes, as in the *Snail* and *Slug*, at the points of these organs. In the latter case, the tentacles are furnished with a very peculiar provision for the protection of the eyes; for when the extremity of either of them is touched, it is drawn-back into the basal part of the organ, much as the finger of a glove may be pushed-back into the palm. The retraction of the tentacle is accomplished by a long muscular slip, which arises within the head, and proceeds to the extremity of the tentacle; whilst its protrusion is effected by the agency of the circular bands with which the tubular wall of the tentacle is itself furnished, the inverted portion being (as it were) squeezed-out by the contraction of the lower part into which it has been drawn-back. The structure of the eyes, and the curious provision just described, may easily be examined by snipping-off one of the eye-bearing tentacles with a pair of scissors.—None but the Cephalopod Mollusks have distinct organs of hearing; but rudiments of such organs may be found in most Gasteropods, attached to some part of the nervous collar that surrounds the œsophagus; and even in many Bivalves, in connection with the nervous ganglion imbedded in the base of the foot. These ‘auditory vesicles,’ as they are termed, are minute sacculi, each of which contains a fluid, wherein are suspended a number of minute calcareous particles (named *otolithes* or ear-stones), which are kept in a state of continual movement by the action of cilia lining the vesicles. This “wonderful spectacle,” as it was truly designated by its discoverer Siebold, may be brought into view without any dissection, by submitting the head of any small and not very thick-skinned Gasteropod, or the young of the

larger forms, to gentle compression under the Microscope, and transmitting a strong light through it. The very early appearance of the auditory vesicles in the embryo Gasteropod has been already alluded-to (§ 350).—Those who have the opportunity of examining young specimens of the common *Pecten*, will find it extremely interesting to watch the action of the very delicate tentacles which they have the power of putting-forth from the margin of their mantle, the animal being confined in a shallow cell, or in the zoophyte-trough; and if the observer should be fortunate enough to obtain a specimen so young that the valves are quite transparent, he will find the spectacle presented by the ciliary movement of the gills, as well as the active play of the foot (of which the adult animal can make no such use), to be worthy of more than a cursory glance.

355. *Chromatophores of Cephalopods*.—Almost any species of Cuttle-fish (*Sepia*) or Squid (*Loligo*) will afford the opportunity of examining the very curious provision which their skin contains for changing its hue. This consists in the presence of numerous large 'pigment-cells,' containing colouring matter of various tints; the prevailing colour, however, being that of the fluid of the ink-bag. These pigment-cells may present very different forms, being sometimes nearly globular, whilst at other times they are flattened and extended into radiating prolongations; and, by the peculiar contractility with which they are endowed, they can pass from one to the other of these conditions, so as to spread their coloured contents over a comparatively-large surface, or to limit them within a comparatively-small area. Very commonly there are different layers of these pigment-cells, their contents having different hues in each layer; and thus a great variety of coloration may be given, by the alteration of the form of the cells of which one or another layer is made-up. It is curious that the changes in the hue of the skin appear to be influenced, as in the case of the Chameleon, by the colour of the surface with which it may be in proximity. The alternate contractions and extensions of these pigment-cells or 'chromatophores' may be easily observed in a piece of skin detached from the living animal, and viewed as a transparent object; since they will continue for some time, if the skin be placed in sea-water. And they may also be well seen in the embryo Cuttle-fish, which will sometimes be found in a state of sufficient advancement, in the grape-like eggs of these animals attached to sea-weeds, zoophytes, &c.

CHAPTER XV.

ANNULOSA, OR WORMS.

356. UNDER the general designation of 'annulose' animals, or Worms, may be grouped-together all that lower portion of the great *Articulated* sub-kingdom, in which the division of the body into longitudinally-arranged segments is not distinctly marked-out, and in which there is an absence of those 'articulated' or jointed limbs, that constitute so distinct a feature of Insects and their allies. This group includes the classes of *Entozoa* or Intestinal Worms, *Rotifera* or Wheel-Animalcules, *Turbellaria*, and *Annelida*; each of which furnishes many objects for Microscopic examination, that are of the highest scientific interest. As our business, however, is less with the professed Physiologist, than with the general enquirer into the minute wonders and beauties of Nature, we shall pass-over these classes (the *Rotifera* having been already treated-of in detail, Chap. ix.), with only a notice of such points as are likely to be specially deserving the attention of observers of the latter order.

357. *Entozoa*.—This class consists almost entirely of animals of a very peculiar plan of organization, which are parasitic within the bodies of other animals, and which obtain their nutriment by the absorption of the juices of these,—thus bearing a striking analogy to the parasitic Fungi (§§ 209-212). The most remarkable feature in their structure, consists in the entire absence, or the extremely low development, of their nutritive system, and the extraordinary development of their reproductive apparatus. Thus, in the common *Tenia* (tape-worm), which may be taken as the type of the 'cestoid' group, there is neither mouth nor stomach, the so-called 'head' being merely an organ for attachment, whilst the segments of the 'body' contain repetitions of a complex generative apparatus, the male and female sexual organs being so united in each, as to enable it to fertilize and bring to maturity its own very numerous eggs; and the chief connection between these segments is established by two pairs of longitudinal canals, which, though regarded by some as representing a digestive appa-

ratus, and by others as a circulating system, appear really to represent the 'water-vascular system,' whose simplest condition has been noticed in the Wheel-animalcule (§ 278).— Few among the recent results of microscopic enquiry have been more curious, than the elucidation of the real nature of the bodies formerly denominated *cystic* Entozoa, which have always ranked until recently as a distinct group. These are not found, like the preceding, in the cavity of the alimentary canal of the animals they infest; but always occur in the substance of solid organs, such as the glands, muscles, &c. They present themselves to the eye as bags or vesicles of various sizes, sometimes occurring singly, sometimes in groups; but upon careful examination, each vesicle is found to bear upon some part a 'head' furnished with hooklets and suckers; and thus may be either single, as in *Cysticercus* (the entozoon whose presence gives to pork what is known as the 'measly' disorder), or multiple, as in *Tæniæ*, which is developed in the brain, chiefly of sheep, giving rise to the disorder known as 'the staggers.' Now in none of these 'cystic' forms has any generative apparatus ever been discovered; and hence they are obviously to be considered as imperfect animals. The close resemblance between the 'head' of certain *Cysticerci* and that of certain *Tæniæ*, first suggested that the two might be different states of the same animal; and experiments recently made by those who have devoted themselves to the working-out of this curious subject, have led to the assured conclusion, that the 'cystic' Entozoa are nothing else than 'cestoid' worms, whose development has been modified by the peculiarity of their position,—the large bag being formed by a sort of dropsical accumulation of fluid when the young are evolved in the midst of solid tissues, whilst the very same bodies, conveyed into the alimentary canal of some carnivorous animal which has fed upon the flesh infested with them, begin to bud-forth the generative segments, the long succession of which, united end to end, gives to the entire series a worm-like aspect.

358. In the intestinal canal of Insects, Centipedes, &c., a very curious kind of animal parasite is often to be met-with, the simplicity of whose structure seems to carry us back to the Protozoa (Chap. ix). It is not yet by any means certain, however, that we know the entire life-history of this parasite, the *Gregarina*; and it may be only a phase in the existence of some higher kind of Entozoon. Each individual essentially consists of a single cell, usually more or less ovate in form,

and sometimes considerably elongated; a sort of beak or proboscis frequently projects from one extremity; and in some instances this is furnished with a circular row of hooklets, closely resembling that which is seen on the head of *Tania*. Within the cavity of the cell, whose contents are usually milk-white and minutely-granular, there is generally seen a pellucid nucleus; and this becomes first constricted and then cleft, when, as often happens, the cell subdivides into two, by a process exactly analogous to that which takes-place in the simplest Protophytes (§ 150). The membrane and its contents, except the nucleus, are soluble in acetic acid. Cilia have been detected both upon the outer and the inner surface; but these would seem destined, not so much to give motion to the body, as to renew the stratum of fluid in contact with it; for such change of place as the animal does exhibit, is effected by the contractions and extensions of the body generally, as in the *Amœba* (§ 261). A sort of 'conjugation' has been seen to take-place between two individuals, whose bodies, coming into contact with each other by corresponding points, first become more globular in shape, and are then encysted by the formation of a capsule around them both; the partition-walls between their cavities disappear; and the substance of the two bodies becomes completely fused-together. As the product of this conjugation, there are first seen a number of globules or cell-like bodies; and these gradually assume a form so like that of *Naviculæ* (§ 184) as to have been mistaken for them; their walls, however, are destitute of silex, and there is no further resemblance between the two kinds of bodies, than that of figure. These 'pseudo-naviculæ' are set-free, in time, by the bursting of the capsule that encloses them; and they develop themselves into a new generation of Gregarinæ, first passing through an *Amœba*-like form. It appears, however, that the 'pseudo-naviculæ' or 'psorosperms' may be also formed by the simple division of the granular matter of a single Gregarina-body, without any conjugation.*

359. The higher forms of Entozoa, belonging to the 'nematoid' or thread-like order—of which the common *Ascaris* may be taken as a type, one species of it (the *A. lumbricoides*, or 'round worm') being a common parasite in the small intestine of man, while another (the *A. vermicularis*, or 'thread worm') is found rather in the lower bowel,—approach

* For the most recent information on this point, see a Memoir by M. Nat. Lieberkuhn in Mem. de l'Acad. Roy. de Belgique, tom. xvi.

more closely to the ordinary type of conformation of Worms ; having a distinct alimentary canal, which commences with a mouth at the anterior extremity of the body, and which terminates by an anal orifice near the other extremity ; and also possessing a regular arrangement of circular and longitudinal muscular fibres, by which the body can be shortened, elongated, or bent in any direction. The smaller species of *Ascaris*, by some or other of which almost every Vertebrated animal is infested, are so transparent, that every part of their internal organization may be made-out, especially with the assistance of the ‘compressor,’ without any dissection ; and the study of the structure and actions of their generative apparatus has yielded many very interesting results, especially in regard to the first formation of the ova, the mode of their fertilization, and the history of their subsequent development. —Some of the worms belonging to this group are not parasitic in the bodies of other animals, but live in the midst of dead or decomposing vegetable matter. The *Gordius* or hair-worm, which is peculiar in not having any perceptible anal orifice, seems to be properly a parasite in the intestines of water-insects ; but it is frequently found in large knot-like masses (whence its name) in the water or mud of the pools inhabited by such insects, and may apparently be developed in these situations. The *Anguillulæ* are little eel-like worms, of which one species, *A. fluviatilis*, is very often found in fresh water amongst *Desmidiæ*, *Confervæ*, &c., also in wet moss and moist earth, and sometimes also in the alimentary canal of snails, frogs, fishes, insects, and larger worms ; whilst another species, *A. trilici*, is met-with in the ears of wheat affected with the blight termed the ‘cockle ;’ another, the *A. glutinis*, is found in sour paste ; and another, the *A. aceti*, was often found in stale vinegar, until the more complete removal of mucilage and the addition of sulphuric acid, in the course of the manufacture, rendered this liquid a less favourable ‘habitat’ for these little creatures. A writhing mass of any of these species of ‘eels,’ is one of the most curious spectacles which the Microscopist can exhibit to the unscientific observer ; and the capability which they all possess (in common with the Rotifera and Tardigrada) of revival after desiccation, at however remote an interval, enables him to command this spectacle at any time. A grain of wheat within which these worms (often called *vibriones*) are being developed, gradually assumes the appearance of a black pepper-corn ; and if it be divided in two, the interior will be found almost

completely filled with a dense white cottony mass, occupying the place of the flour, and leaving merely a small space for a little glutinous matter. The cottony substance seems to the eye to consist of bundles of fine fibres closely packed-together; but on taking-out a small portion, and putting it under the microscope with a little water under a thin-glass cover, it will be found after a short time (if not immediately) to be a wriggling mass of life, the apparent fibres being really *Anguillulae*, or the 'cels' of the Microscopist. If the seeds be soaked in water for a couple of hours before they are laid-open, the cels will be found in a state of activity from the first; their movements, however, are by no means so energetic as those of the *A. glutinis* or 'paste-cel.' This last frequently makes its appearance spontaneously in the midst of paste that is turning sour; but the best means of securing a supply for any occasion, consists in allowing any portion of a mass of paste in which they may present themselves, to dry-up, and then, laying this by so long as it may not be wanted, to introduce it into a mass of fresh paste, which, if it be kept warm and moist, will be found after a few days to swarm with these curious little creatures.

360. Besides the foregoing orders of Entozoa, the 'trematode' group must be named; of which the *Distoma hepaticum*, or 'fluke,' found in the livers of sheep affected with the 'rot,' is a typical example. Into the details of the structure of this animal, which has the general form of a sole, there is no occasion for us here to enter: it is remarkable, however, for the branching form of its digestive cavity, which extends throughout almost the entire body, very much as in the Planariæ (Fig 273); and also for the curious phenomena of its development, several distinct forms being passed-through between one sexual generation and another. These have been especially studied in the *Distoma* which infests the *Lymnaeus*; the ova of which are not developed into the likeness of their parents, but into minute worm-like bodies, which seem to be little else than masses of cells inclosed in a contractile integument, no formed organs being found in them; these cells, in their turn, are developed into independent 'zooids,' which escape from their containing cyst in the condition of free ciliated animalcules; in this condition they remain for some time, and then imbed themselves in the mucus that covers the tail of the Mollusk, in which they undergo a gradual development into true Distomata; and having thus acquired their perfect form, they penetrate the soft integument,

and take-up their habitation in the interior of the body. Thus a considerable number of Distomata may be produced from a single ovum, by a process of cell-multiplication in an early stage of its development. In some instances, the free ciliated larva possesses distinct eyes; although they are wanting in the fully-developed Distoma, the peculiar 'habitat' of which would render them useless.

361. *Turbellaria*.—This group of animals, which is distinguished by the presence of cilia over the entire surface of the body, seems intermediate in some respects between the 'trematode' Entozoa and the Leech-tribe among Annelida. It deserves special notice here, chiefly on account of the frequency with which the worms of the *Planarian* tribe present themselves among collections both of marine and of fresh-water animals (particular species inhabiting either locality), and on account of the curious organization which many of these present. Most of the members of this tribe have elongated flattened bodies, and move by a sort of gliding or crawling action over the surfaces of aquatic plants and animals. Some of the smaller kinds are sufficiently transparent to allow of their internal structure being seen by transmitted light, especially when they are slightly compressed; and the accompanying figure (Fig 273) displays the general conformation of their principal organs, as thus seen. The body has the flattened sole-like shape of the 'trematode' Entozoa; its mouth, which is situated at a considerable distance from the anterior extremity of the body, is surrounded by a circular sucker, that is applied to the living surface from which the animal draws its nutriment; and the buccal cavity (*b*) opens into a short œsophagus (*c*), which leads at once to the cavity of the stomach. In the true *Planaria*, the mouth is furnished with a sort of long funnel-shaped proboscis; and this, even when detached from the body, continues to swallow anything presented to it. The cavity of the stomach does not give origin to any intestinal tube, nor is it provided with any second orifice; but a large number of ramifying canals are prolonged from it, which carry its contents into every part of the body. This seems to render unnecessary any system of vessels for the circulation of nutritive fluids; and the two principal trunks, with connecting and ramifying branches, which may be observed in them, are probably to be regarded in the light of a 'water-vascular' system, the function of which is essentially respiratory. Both sets of sexual organs are combined in the same individuals; though the congress of

two, each impregnating the ova of the other, seems to be generally necessary. The ovaria, as in the Entozoa, extend through a large part of the body, their ramifications proceeding from the two oviducts (*k, k*), which have a dilatation (*l*) at their point of junction. There is much obscurity about the history of the embryonic development of these animals; and the facts observed by Siebold seem to be best explained upon the hypothesis, that what has been usually considered as an egg is really an egg-capsule containing several embryos with a store of supplemental yolk, as in *Purpura* (§ 351), which yolk is swallowed by the embryos at a very early period of their development within the capsule. After their emersion from the capsule, the embryos bear so strong a resemblance to certain Infusoria, as to have led Prof. Agassiz to

FIG. 273.

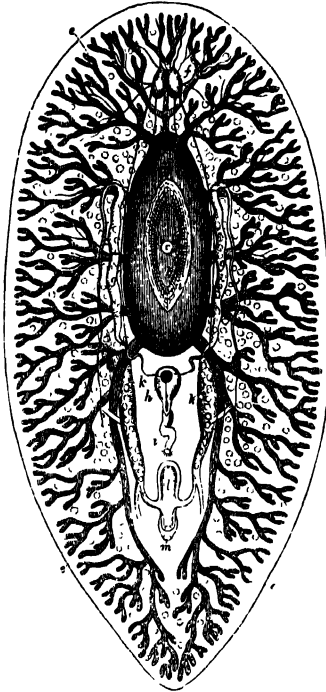

Structure of *Polyclis levigatus* (a Planarian worm): *a*, mouth, surrounded by its circular sucker; *b*, buccal cavity; *c*, oesophageal orifice; *d*, stomach; *e*, ramifications of gastric canals; *f*, cephalic ganglia and their nervous filaments; *g, g*, testes; *h*, vesicula seminalis; *i*, male genital canal; *k, k*, oviducts; *l*, dilatation at their point of junction; *m*, female genital orifice.

the conclusion, that the genera *Paramecium* and *Kolpoda* are nothing else than Planarian larvæ (§ 266, note). This point, how-

ever, is still a matter for investigation.* The Planariæ, however, do not multiply by eggs alone; for they occasionally undergo spontaneous fission in a transverse direction, each segment becoming a perfect animal; and an artificial division into two or even more parts may be practised with a like result. In fact, the power of the Planariæ to reproduce portions which have been removed, seems but little inferior to that of the Hydra (§ 301); a circumstance which is peculiarly remarkable, when the much higher character of their organization is borne in mind. They possess a distinct pair of nervous ganglia (*ff*), from which branches proceed to various parts of the body; and in the neighbourhood of these are usually to be observed a number (varying from 2 to 40) of *ocelli*, or rudimentary eyes, each having its refracting body or crystalline lens, its pigment layer, its nerve-bulb, and its cornea-like bulging of the skin. The integument of many of these animals is furnished with 'thread-cells' or 'filiferous capsules,' very much resembling those of Zoophytes (§ 310).

362. *Annelida*.—This class includes all the higher kinds of worm-like animals, the greater part of which are marine, though there are several species which inhabit fresh water, and some which live on land. The body in this class is usually very long, and nearly always presents a well-marked segmental division, the segments being for the most part similar and equal to each other, except at the two extremities; but in the lower forms, such as the *Lecch* and its allies, the segmental division is very indistinctly seen, on account of the general softness of the integument. A large proportion of the marine Annelids have special respiratory appendages, into which the fluids of the body are sent for aeration; and these are situated upon the head (Fig. 274), in those species which (like the *Serpula*, *Terebella*, *Sabellaria*, &c.) have their bodies enclosed by tubes, either formed of a shelly substance produced from their own surface, or built-up by the agglutination of grains of sand, fragments of shell, &c.; whilst they are distributed along the two sides of the body, in such as swim freely through the water, or crawl over the surfaces of rocks, as is the case with the *Nereida*, or simply bury themselves in the sand, as the *Arenicola* or 'lob-worm.' In these respiratory appendages, the circulation of the fluids may be distinctly seen by microscopic examination; and these fluids

* See § 129 of Siebold and Stannius's "Vergleichende Anatomie;" also "Muller's Archiv," 1850, p. 455.

FIG. 274.

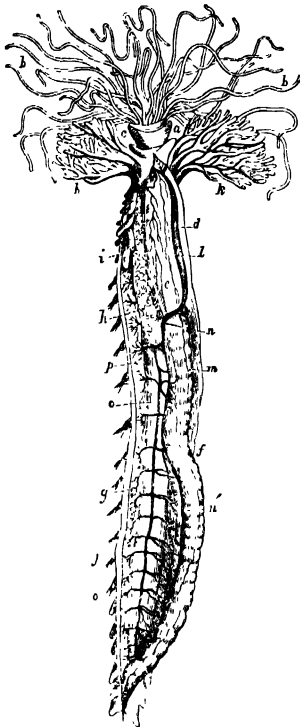

Circulating Apparatus of *Terebella conchilega*.—*a*, labial ring; *b, b*, tentacula; *c*, first segment of the trunk; *d*, skin of the back; *e*, pharynx; *f*, intestine; *g*, longitudinal muscles of the inferior surface of the body; *h*, glandular organ (liver?); *i*, organs of generation; *j*, feet; *k, k*, branchiæ; *l*, dorsal vessel acting as a respiratory heart; *m*, dorso-intestinal vessel; *n*, venous sinus surrounding oesophagus; *n'*, inferior intestinal vessel; *o, o*, ventral trunk; *p*, lateral vascular branches.

are of two kinds,—first, a colourless fluid, containing numerous cell-like corpuscles, which can be seen in the smaller and more transparent species to occupy the space that intervenes between the outer surface of the alimentary canal and the inner wall of the body, and to pass from this into canals which often ramify extensively in the respiratory organs, but are never furnished with a returning series of passages,—and second, a fluid which is usually red, contains few floating particles, and is enclosed in a system of proper vessels, that communicates with a central propelling organ, and not only carries the fluid away from this, but also brings it back again. In *Terebella*, we find a distinct provision for the aeration of both fluids; for the first is transmitted to the tendril-like tentacula which surround the mouth (Fig. 274, *b, b*), whilst the second circulates through the beautiful arborescent branchiæ (*k, k*) situated just behind the head. The former are covered with cilia, the action of which continually renews the stratum of water in contact with them, whilst the latter are destitute of

these organs; and this seems to be the general fact as to the several appendages to which these two fluids are respectively sent for aeration, the nature of their distribution varying greatly in the different members of the class. The red fluid is commonly considered as blood, and the tubes through which it circulates as blood-vessels: but the Author has elsewhere given his reasons* for coinciding in the opinion of Mr. Huxley, that the colourless corpusculated fluid which moves in the general cavity of the body and in its extensions, is that which really represents the blood of other Articulated Animals; and that the system of vessels carrying the red fluid is to be likened on the one hand to the 'water-vascular system' of the inferior Worms, and on the other to the tracheal apparatus of Insects (§ 391).

363. In the observation of the beautiful spectacle presented by the respiratory circulation of the various kinds of Annelids which swarm on most of our shores, and in the examination of what is going-on in the interior of their bodies (where this is rendered possible by their transparency), the Microscopist will find a most fertile source of interesting occupation, and may easily, with care and patience, make many valuable additions to our present stock of knowledge on these points. There are many of these marine Annelids, in which the appendages of various kinds put-forth from the sides of their bodies, furnish very beautiful microscopic objects; as do also the different forms of teeth, jaws, &c., with which the mouth is commonly armed in the free or non-tubicolous species, these being eminently carnivorous.—The early history of their development, too, is extremely curious; for they come-forth from the egg in a condition very little more advanced than the ciliated gemmules of polypes, consisting of a globular mass of untransformed cells, certain parts of whose surface are covered with cilia; in a few hours, however, this embryonic mass elongates, and indications of a segmental division become apparent, the head being (as it were) marked-off in front, whilst behind this is a large segment thickly covered with cilia, then a narrower and non-ciliated segment, and lastly the caudal or tail-segment which is furnished with cilia. A little later, a new segment is seen to be interposed in front of the caudal; and the dark internal granular mass shapes itself into the outline of an alimentary canal. The number of segments progressively increases by

* See his "Principles of Comparative Physiology," 4th Edit., §§ 218, 219, 292

the interposition of new ones between the caudal and its preceding segments; the various internal organs become more and more distinct, eye-spots make their appearance, little bristly appendages are put-forth from the segments, and the animal gradually assumes the likeness of its parent; a few days being passed by the tubicolar kinds, however, in the actively-moving condition, before they settle-down to the formation of a tube. In places where Annelida abound, free-swimming larvæ are often to be obtained at the same time and in the same manner as those of the Echinoderms (§ 323); but to carry-out any systematic observations on their embryonic development, the eggs should be searched-for in the situations which these animals haunt — To one other phenomenon of the greatest interest, presented by various small marine Annelida, the attention of the Microscopist should be specially directed; this is their *luminosity*, which is not a steady glow like that of the glow-worm or fire-fly, but a series of vivid scintillations (strongly resembling those produced by an electric discharge through a tube spotted with tin-foil), that pass along a considerable number of segments, lasting for an instant only, but capable of being repeatedly excited by any irritation applied to the body of the animal. These scintillations may be discerned under the microscope, even in separated segments, when they are subjected to the irritation of a needle-point or to a gentle pressure; and it has been ascertained by the careful observations of M. de Quatrefages, that they are given-out by the muscular fibres in the act of contraction.*

364. Among the fresh-water *Annelida*, those most interesting to the Microscopist are the worms of the *Nais* tribe, which are common in our rivers and ponds, living chiefly amidst the mud at the bottom, and especially among the roots of aquatic plants. Being blood-red in colour, they give to the surface of the mud, when they protrude themselves from it in large numbers and keep the protruded portion of their bodies in constant undulation, a very peculiar appearance; but if disturbed, they withdraw themselves suddenly and completely. These worms, from the extreme transparency of their bodies, present peculiar facilities for microscopic examination, and especially for the study of the internal circulation of the red liquid commonly considered as blood. There are here no external respiratory organs; and the thinness of the general integument appears to supply all needful facility for the aeration of the fluids. One large vascular trunk (dorsal) may

* See his Memoirs on the Annelida of La Manche, in "Ann. des Sci. Nat.," Sér. 2, tom. XIX, and Sér. 3, tom. XIV.

be seen lying above the intestinal canal, and another (ventral) beneath it ; and each of these enters a contractile dilatation, or heart-like organ, situated just behind the head. The fluid moves forwards in the dorsal trunk as far as the heart, which it enters and dilates ; and when this contracts, it propels the fluid partly to the head, and partly to the ventral heart, which is distended by it. The ventral heart, contracting in its turn, sends the blood backwards along the ventral trunk to the tail, whence it passes towards the head as before. In this circulation, it branches-off from each of the principal trunks into numerous vessels proceeding to different parts of the body, which then return into the other trunk ; and there is a peculiar set of vascular coils, hanging-down in the perigastric space that contains the corpusculated liquid representing the true blood, which seem specially destined to convey to it the aerating influence received by the red fluid in its circuit, thus acting (so to speak) like internal gills. The *Naid*-worms have been observed to undergo spontaneous division during the summer months, a new head and its organs being formed for the posterior segment behind the line of constriction, before its separation from the anterior. It has been generally believed that each segment continues to live as an entire worm ; but Dr. T. Williams has lately asserted, that from the time when the division occurs, neither half takes-in any more food, and that the two segments only retain vitality enough to enable them to be (as it were) the 'nurses' of the eggs which both include.—In the *Leech* tribe, the apparatus of teeth with which the mouth is furnished, is one of the most curious among their points of minute structure ; and the common 'medicinal' leech affords one of the most interesting examples of it. What is commonly termed the 'bite' of the leech, is really a saw-cut, or rather a combination of three saw-cuts, radiating from a common centre. If the mouth of the leech be examined with a hand-magnifier, or even with the naked eye, it will be seen to be a triangular aperture in the midst of a sucking disk ; and on turning-back the lips of that aperture, three little white ridges are brought into view. Each of these is the convex edge of a horny semi-circle, which is bordered by a row of eighty or ninety minute hard and sharp teeth ; whilst the straight border of the semi-circle is imbedded in the muscular substance of the disk, by the action of which it is made to move backwards and forwards in a saw-like manner, so that the teeth are enabled to cut-into the skin to which the suctorial disk has affixed itself.

CHAPTER XVI.

CRUSTACEA.

PASSING from the lower division of the Articulated series to the higher—that in which the body is furnished with distinctly-articulated or jointed limbs,—we come first to the class of *Crustacea*, which includes (when used in its most comprehensive sense) all those animals belonging to this group, which are fitted for aquatic respiration. It thus comprehends a very extensive range of forms; for although we are accustomed to think of the Crab, Lobster, Cray-fish, and other well-known species of the order *Decapoda* (ten-footed), as its typical examples, yet all these belong to the highest of its many orders; and among the lower are many of a far simpler structure, and not a few which would not be recognised as belonging to the class at all, were it not for the information derived from the study of their development as to their real nature, which is far more apparent in their early than it is in their adult condition. Many of the inferior kinds of Crustacea are so minute and transparent, that their whole structure may be made-out by the aid of the Microscope without any preparation; this is the case, indeed, with nearly the whole group of *Entomostraca* (§ 366), and with the larval forms even of the *Crab* and its allies (§ 375); and we shall give our first attention to these, afterwards noticing such points in the structure of the larger kinds, as are likely to be of general interest.

365. One of the most curious examples of the reduction of an elevated type to its very simplest form, which the Animal Kingdom affords, is presented by the group of *Pycnogonidæ*; some members of which may be found by attentive search in almost every locality where sea-weeds abound, it being their habit to crawl (or rather to sprawl) over the surfaces of these, and probably to imbibe as food the gelatinous substance with which they are invested. The general form of their bodies (Fig. 275) usually reminds us of that of some of the long-legged Crabs; the abdomen being almost or altogether

deficient, whilst the head is very small, and fused (as it were) into the thorax; so that the last-named region, with the members attached to it, constitutes nearly the whole bulk of the animal. The head is extended in front into a proboscis-

FIG. 275.

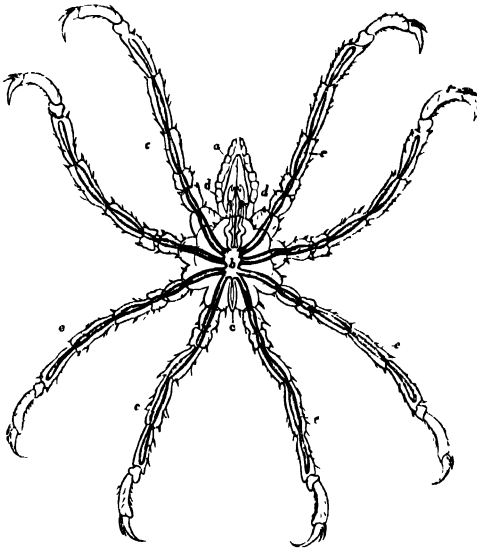

Ammothera pycnogonoides.—*a*, narrow œsophagus; *b*, stomach; *c*, intestine; *d*, digestive caeca of the feet-jaws; *e, e*, digestive caeca of the legs.

like projection, at the extremity of which is the narrow orifice of the mouth; which seems to be furnished with vibratile cilia, that serve to draw into it the semi-fluid aliment. Instead of being furnished (as in the higher Crustaceans) with two pairs of antennæ and numerous pairs of 'feet-jaws,' it has but a single pair of either; it also bears four minute *ocelli*, or rudimentary eyes, set at a little distance from each other on a sort of tubercle. From the thorax proceed four pairs of legs, each composed of several joints, and terminated by a hooked claw; and by these members the animal drags itself slowly along,

instead of walking actively upon them like a crab. The mouth leads to a very narrow œsophagus (*a*), which passes back to the central stomach (*b*), situated in the midst of the thorax, from the hinder end of which a narrow intestine (*c*) passes-off, to terminate at the posterior extremity of the body. From the central stomach, five pairs of cœcal prolongations radiate; one pair (*d*) entering the feet-jaws, the other four (*e, e*) penetrating the legs, and passing along them as far as the last joint but one; and these extensions are covered with a layer of brownish-yellow granules, which are probably to be regarded as a diffused and rudimentary condition of the liver. The stomach and its cœcal prolongations are continually executing peristaltic movements of a very curious kind; for they contract and dilate with an irregular alternation, so that a flux and reflux of their contents is constantly taking-place between the central portion and its radiating extensions, and between one of these extensions and another. The space between the widely-extended stomach and the walls of the body and limbs is occupied by a transparent liquid, in which are seen floating a number of minute transparent corpuseles of irregular size; and this fluid, which represents the blood, is kept in continual motion, not only by the general movements of the body and limbs, but also by the actions of the digestive apparatus; since, whenever the cœcum of any one of the legs undergoes dilatation, a part of the circumambient liquid will be pressed-out from the cavity of that limb, either into the thorax, or into some other limb whose stomach is contracting. The fluid must obtain its aeration through the general surface of the body, as there are no special organs of respiration. The nervous system consists of a single ganglion in the head (formed by the coalescence of a pair), and of another in the thorax (formed by the coalescence of four pairs), with which the cephalic ganglion is connected in the usual mode, namely, by two nervous cords which diverge from each other to embrace the œsophagus. Of the reproduction of this animal, nothing is yet known.—In the study of the very curious phenomena exhibited by the digestive apparatus, as well as of the various points of internal conformation which have been described, the achromatic condenser will be found useful, even with the 1 inch, 2-3rds inch, or $\frac{1}{2}$ inch objectives; for the imperfect transparence of the bodies of these animals renders it of importance to drive a large quantity of light through them, and to give to this light such a quality, as shall define the internal organs as sharply as possible.

366. The *Entomostracous* group of Crustaceans, nearly all the existing members of which are of such minute size as to be only just visible to the naked eye, is distinguished by the enclosure of the entire body within a horny or shelly casing, which sometimes closely resembles a bivalve shell in form and in the mode of junction of its parts, whilst in other instances it is formed of only a single piece, like the hard envelope of certain Rotifera (§ 282, III). The segments into which the body is divided, are frequently very numerous, and are for the most part similar to each other; but there is a marked difference in regard to the appendages which they bear, and to the mode in which these minister to the locomotion of the animals. For in the *Lophyropoda*, or bristly-footed tribe, the number of legs is small, not exceeding five pairs, and their function is limited to locomotion, the respiratory organs being attached to the parts in the neighbourhood of the mouth; whilst in the *Branchiopoda*, or gill-footed tribe, the same members serve both for locomotion and for respiration, and the number of these is commonly large, being in *Apus* not less than sixty pairs. The character of their movements differs accordingly; for whilst all the members of the first-named tribe dart through the water in a succession of jerks, so as to have acquired the common name of 'water-fleas,' those among the latter which possess a great number of 'fin-feet,' swim with an easy gliding movement, sometimes on their back alone (as is the case with *Branchipus*), sometimes with equal facility on the back, belly, or sides (as is done by *Artemia salina*, the 'brine shrimp').—Some of the most common forms of both tribes will now be briefly noticed.

367. The tribe of *Lophyropoda* is divided into two orders; of which the first, *Ostracoda*, is distinguished by the complete enclosure of the body in a bivalve shell, by the small number of legs, and by the absence of an external ovary. One of the best-known examples is the little *Cypris*, which is a common inhabitant of pools and streams; this may be recognised by its possession of two pairs of antennæ, the first having numerous joints with a pencil-like tuft of filaments, and projecting forwards from the front of the head, whilst the second has more the shape of legs, and is directed downwards; and by the limitation of its legs to two pairs, of which the posterior does not make its appearance outside the shell, being bent upwards to give support to the ovaries. The valves are generally opened sufficiently wide, to allow the greater part of both pairs of antennæ, and of the front pair of legs, to pass-out

between them; but when the animals are alarmed, they draw these members within the shell, and close the valves firmly. They are very lively creatures, being almost constantly seen in motion, either swimming by the united action of their foot-like antennæ and legs, or walking upon plants and other solid bodies floating in the water.—Nearly allied to the preceding is the *Cythere*, whose body is furnished with three pairs of legs, all projecting out of the shell, and whose superior antennæ are destitute of the filamentous brush; this genus is almost entirely marine, and some species of it may almost invariably be met-with in little pools among the rocks between the tide-marks, creeping-about (but not swimming) amongst Confervæ and Corallines. There is abundant evidence of the former existence of Crustacea of this group, of larger size than any now existing, to an enormous extent; for in certain fresh-water strata, both of the Secondary and Tertiary series, we find layers, sometimes of great extent and thickness, which are almost entirely composed of the fossilized shells of *Cyprides*; whilst in certain parts of the Chalk, which was a marine deposit, the remains of bivalve shells resembling those of *Cythere*, present themselves in such abundance as to form a considerable part of its composition.—In the order *Copepoda*, there is a jointed shell forming a kind of buckler that almost entirely encloses the head and thorax, an opening being left beneath, through which the members project; and there are five pairs of legs, mostly adapted for swimming, the fifth pair, however, being rudimentary in the genus *Cyclops*, the commonest example of the group. This genus receives its name from possessing only a single eye, or rather a single cluster of ocelli; which character, however, it has in common with the two genera already named, as well as with *Daphnia* (§ 368), and with many other Entomostraca. It contains numerous species, some of which belong to fresh water, whilst others are marine. The fresh-water species often abound in the muddiest and most stagnant pools, as well as in the clearest springs; the ordinary water with which London is supplied, frequently contains large numbers of them. Of the marine species, some are to be found in the localities in which the *Cythere* is most abundant, whilst others inhabit the open ocean, and must be collected by a fine muslin net. The body of the *Cyclops* is soft and gelatinous, and it is composed of two distinct parts, a thorax (Fig. 276, *a*) and an abdomen (*b*), of which the latter, being comparatively slender, is commonly considered as a tail, though traversed by the intestine which

terminates near its extremity. The head, which coalesces with the thorax, bears one very large pair of antennæ (c) possessing numerous articulations, and furnished with bristly appendages, and another small pair (d); it is also furnished with a pair of 'mandibles' or true jaws, and with two pairs of 'feet-jaws,' of which the hinder pair is the longer, and most abundantly supplied with bristles. The legs (e) are all beset with plumose tufts, as is also the tail (f, f) which is borne at the extremity of the abdomen.

FIG. 276.

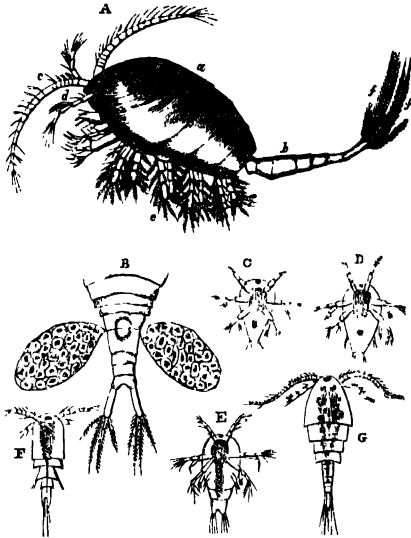

A, female of *Cyclops quadricornis*:—a, body; b, tail; c, antenna; d, antennule; e, feet; f, plumose setae of tail.—B, tail, with external egg-sacs.—C, D, E, F, G, successive stages of development of young.

On either side of the abdomen of the female, there is often to be seen an egg-capsule or external ovarium (B), within which the ova, after being fertilized, undergo the earlier stages of their development. The Cyclops is a very active creature, and strikes the water in swimming, not merely with its legs and tail, but also with its antennæ. The rapidly-repeated movements of its feet-jaws serve to create a whirlpool in the surrounding water, by which minute animals of various kinds, and even its own young, are brought to its mouth to be devoured.

368. The tribe of Branchiopoda also is divided into two orders; of which the *Cladocera* present the nearest approach

to the preceding, having a bivalve carapace, no more than from four to six pairs of legs, two pairs of antennæ, of which one is large and branched and adapted for swimming, and a single eye. The commonest form of this is the *Daphnia pulex*, sometimes called the 'arborescent water-flea' from the branching form of its antennæ. It is very abundant in many ponds and ditches, coming to the surface in the mornings and evenings and in cloudy weather, but seeking the depths of the water during the heat of the day. It swims by taking short springs; and feeds on minute particles of vegetable substances, not, however, rejecting animal matter when offered. Some of the peculiar phenomena of its reproduction will be presently described (§ 370).—The order *Phyllopoda* includes those Branchiopoda whose body is divided into a great number of segments, nearly all of which are furnished with leaf-like members, or 'fin-feet.' The two families which this order includes, however, differ considerably in their conformation; for in that of which the genera *Apus* and *Nebalia* are representatives, the body is enclosed in a shell, either shield-like or bivalve, and the feet are generally very numerous; whilst in that which contains *Branchipus* and *Artemia*, the body is entirely unprotected, and the number of pairs of feet does not exceed eleven. The *Apus caucrisiformis*, which is an animal of comparatively large size, its entire length being about $2\frac{1}{2}$ inches, is an inhabitant of stagnant waters; but although occasionally very abundant in particular pools or ditches, it is not to be met with nearly so commonly as the Entomostraca already noticed. It is recognised by its large oval carapace, which covers the head and body like a shield; by the nearly-cylindrical form of its body, which is composed of thirty articulations; and by the multiplication of its legs, which amount to about sixty pairs. The number of joints in these and in the other appendages is so great, that in a single individual they may be safely estimated at not less than two millions. These organs, however, are for the most part small; and the instruments chiefly used by the animal for locomotion are the first pair of feet, which are very much elongated (bearing such a resemblance to the principal antennæ of other Entomostraca, as to be commonly ranked in the same light), and are distinguished as *rami* or oars. With these they can swim freely in any position; but when the 'rami' are at rest and the animal floats idly on the water, its fin-feet may be seen to be in incessant motion, causing a sort of whirlpool in the water, and bringing to the mouth the minute animals (chiefly the smaller

Entomostraca inhabiting the same localities) that serve them as food.—The *Branchipus stagnalis* has a slender, cylindrical, and very transparent body of nearly an inch in length, furnished with eleven pairs of fin-feet, but is destitute of any protecting envelope; its head is furnished with a pair of very curious prehensile organs (which are really modified antennæ), whence it has received the name of *Cheirocephalus*; but these are not used by it for the seizure of prey, the food of this animal being vegetable, and their function is to clasp the female in the act of copulation. The *Branchipus* or *Cheirocephalus* is certainly the most beautiful and elegant of all the Entomostraca, being rendered extremely attractive to the view by “the uninterrupted undulatory wavy motion of its graceful branchial feet, slightly tinged as they are with a light reddish hue, the brilliant mixture of transparent bluish green and bright red of its prehensile antennæ, and its bright red tail with the beautiful plumose setæ springing from it:” unfortunately, however, it is a comparatively rare animal in this country. The *Artemia salina* or ‘brine shrimp’ is an animal of very similar organization, and almost equally beautiful in its appearance and movements, but of smaller size, its body being about half an inch in length. Its ‘habitat’ is very peculiar; for it is only found in the salt-pans or brine-pits in which sea-water is undergoing concentration (as at Lynington); and in these situations it is sometimes so abundant, as to communicate a red tinge to the liquid.

369. Some of the most interesting points in the history of the Entomostraca lie in the peculiar modes in which their Generative function is performed, and in their tenacity of life when desiccated, in which last respect they correspond with many Rotifera (§ 280). This provision is obviously intended to prevent them from being completely exterminated, as they might otherwise soon be, by the drying-up of the pools, ditches, and other small collections of water which constitute their usual ‘habitats.’ It does not appear, however, that the adult animals can bear a *complete* desiccation, although they will preserve their vitality in mud that holds the smallest quantity of moisture; but their eggs are more tenacious of life, and there is ample evidence that these will become fertile on being moistened, after having continued for a long time in the condition of fine dust. Most Entomostraca, too, are killed by severe cold, and thus the whole race of adults perishes every winter; but their eggs seem unaffected by the lowest temperature, and thus continue the species which

would otherwise be exterminated.—Again, we frequently meet in this group with that reproduction by gemmation, which we have seen to prevail so extensively among the lower Radiata and Mollusca. In many species there is a double mode of multiplication, the sexual and the non-sexual. The former takes place at certain seasons only, the males (which are often so different in conformation from the females, that they would not be supposed to belong to the same species, if they were not seen in actual congress) disappearing entirely at other times; whilst the latter continues at all periods of the year, so long as warmth and food are supplied, and is repeated many times (as in the Hydra), so as to give origin to as many successive ‘broods.’ Further, a single act of impregnation serves to fertilize not merely the ova which are then mature or nearly so, but all those subsequently produced by the same female, which are deposited at considerable intervals. In these two modes, the multiplication of these little creatures is carried on with great rapidity, the young animal speedily coming to maturity and beginning to propagate; so that, according to the computation of Jurine, founded upon data ascertained by actual observation, a single fertilized female of the common *Cyclops quadricornis* may be the progenitor in one year of 4,442,189,120 young.

370. The eggs of some Entomostraca are deposited freely in the water, or are carefully attached in clusters to aquatic plants; but they are more frequently carried for some time by the parent in special receptacles developed from the posterior part of the body; and in many cases they are retained there until the young are ready to come-forth, so that these animals may be said to be ovo-viviparous. In the *Daphnia*, the eggs are received into a large cavity between the back of the animal and its shell, and there the young undergo almost their whole development, so as to come-forth in a form nearly resembling that of their parent. Soon after their birth, a moult or exuviation of the shell takes place; and the egg-coverings are cast-off with it. In a very short time afterwards, another brood of eggs is seen in the cavity, and the same process is repeated, the shell being again exuviated after the young have been brought to maturity. At certain times, however, the *Daphnia* may be seen with a dark opaque substance within the back of the shell, which has been called the *ephippium* from its resemblance to a saddle. This, when carefully examined, is found to be of dense texture, and to be composed of a mass of hexagonal cells; and it contains

two oval bodies, each consisting of an ovum covered with a horny casing, enveloped in a capsule which opens like a bivalve shell. The first traces of the 'ephippium' are seen after the third moult, as a green matter in the ovaries, which differs both in colour and appearance from that of the eggs; after the fourth moult, this green matter passes from the ovaries into the matrix or open space on the back, and there becomes developed into the 'ephippium;' and at the fifth moult this is thrown-off, and the ephippium, with the two eggs enclosed, floats on the water until the next spring, when the young are hatched with the returning warmth of the season. This curious provision is obviously destined to afford protection to the eggs which are to endure the severity of winter cold; and some approach to it may be seen in the remarkable firmness of the envelopes of the 'winter eggs' of some of the Rotifera (§ 279). It has been ascertained by Dr. Baird, that the young produced from the ephippial eggs have the same power of continuing the race by non-sexual reproduction, as the young developed under ordinary circumstances.

371. In most Entomostraca, the young at the time of their emersion from the egg differ considerably from the parent, especially in having only the thoracic portion of the body as yet evolved, and in possessing but a small number of locomotive appendages; the visual organs, too, are frequently wanting at first. (See Fig. 276, c-g.) The process of development, however, takes place with great rapidity; the animal at each successive moult (which process is very commonly repeated at intervals of a day or two) presenting some new parts, and becoming more and more like its parent, which it very early resembles in its power of multiplication, the female laying eggs before she has attained her own full size. Even when the Entomostraca have attained their full growth, they continue to exuviate their shell at short intervals during the whole of life; and the purpose which seems to be answered by this repeated moulting, is the preventing the animal from being injured, or its movements obstructed, by the overgrowth of parasitic *Animalecules* and *Confervæ*; weak and sickly individuals being frequently seen to be so covered with such parasites, that their motion and life are soon arrested, apparently because they have not strength to cast-off and renew their envelopes. The process of development appears to depend in some degree upon the influence of light, being retarded when the animals are secluded from it; but its rate is still more influenced by heat; and this appears also to be

the chief agent that regulates the time which elapses between the moultings of the adult, these, in the *Daphnia*, taking-place at intervals of two days in warm summer weather, whilst several days intervene between them when the weather is colder. The cast shell carries with it the sheaths not only of the limbs and plumes, but of the most delicate hairs and setæ which are attached to them. If the animal have previously sustained the loss of a member, it is generally renewed at the next moult, as in higher Crustacea.*

372. Closely connected with the Entomostracous group is the tribe of *Suctorial* Crustacea; which for the most part live as parasites upon the exterior of other animals (especially Fish), whose juices they imbibe by means of the peculiar proboscis-like organ which takes in them the place of the jaws of other Crustaceans; whilst other appendages, representing the feet-jaws, are furnished with hooks, by which these parasites attach themselves to the animals from whose juices they derive their nutriment. Many of the Suctorial Crustacea bear a strong resemblance, even in their adult condition, to certain Entomostraca; but more commonly it is between the earlier forms of the two groups that the resemblance is the closest, most of the *Suctorial* undergoing such extraordinary changes in their progress towards the adult condition, that if their complete forms were alone attended-to, they might be excluded from the class altogether, as has (in fact) been done by many Zoologists.—Among those Suctorial Crustacea which present the nearest approach to the ordinary Entomostracous type, may be specially mentioned the *Argulus foliaceus*, which attaches itself to the surface of the bodies of fresh-water fish, and is commonly known under the name of the 'fish-louse.' This animal has its body covered with a large firm oval shield, which does not extend, however, over the posterior part of the abdomen. The mouth is armed with a pair of styliform mandibles; and on each side of the proboscis there is a large short cylindrical appendage, terminated by a curious sort of sucking disk, with another pair of longer jointed members, terminated by prehensile hooks. These two pairs of appendages, which are probably to be considered as representing the feet-jaws, are followed by four pairs of legs, which, like those of the Branchiopoda, are chiefly adapted for swimming; and the tail, also, is a kind of swimmeret. This little animal can leave the fish upon which it feeds, and then swims freely in

* For a complete and detailed account of this group, see Dr. Baird's "Natural History of the British Entomostraca," published by the Ray Society.

the water, usually in a straight line, but frequently and suddenly changing its direction, and sometimes turning over and over several times in succession. The stomach is remarkable for the large cæcal prolongations which it sends-out on either side, immediately beneath the shell; for these subdivide and ramify in such a manner, that they are distributed almost as minutely as the cæcal prolongations of the stomach of the *Planaria* (Fig. 273). The proper alimentary canal, however, is continued backwards from the central cavity of the stomach, as an intestinal tube, which terminates in an anal orifice at the extremity of the abdomen.*

373. From the parasitic suctorial Crustacea, the transition is not really so abrupt as it might at first sight appear, to the class of *Cirrhipeda*, consisting of the *Barnacles* and their allies; which, like many of the Suctoria, are fixed to one spot during the adult portion of their lives, but come into the world in a condition that bears a strong resemblance to the early state of many of the true Crustacea. The departure from the ordinary Crustacean type in the adult, is, in fact, so great, that it is not surprising that Zoologists in general should have separated them; their superficial resemblance to the Mollusca, indeed, having caused most systematists to rank them in that series, until due weight was given to those structural features which mark their Articulated character. We must limit ourselves in our notice of this group, to that very remarkable part of their history, the Microscopic study of which has contributed most essentially to the elucidation of their real nature. The observations of Mr. J. V. Thompson,† with the extensions and rectifications which they have subsequently received from others, show that there is no essential difference between the early forms of the *sessile* (Balanidæ, or 'acorn-shells') and of the *pedunculated* Cirrhipeds (Lepadidæ or 'barnacles'); for that both are active little animals (Fig. 277, A), possessing three pairs of legs and a pair of compound eyes, and having the body covered with an expanded shield, like that of many Entomostracous Crustaceans, so as in no essential particular to differ from the larva of *Cyclops* (Fig. 276, c). After going through a series of metamorphoses, one stage of which is represented in

* As this group is rather interesting to the professed Naturalist than to the amateur Microscopist, even an outline view of it would be unsuitable to the present treatise; and the Author would refer such of his readers as may desire to study it, to the admirable treatise by Dr. Baird already referred-to.

† "Zoological Researches," No. III., 1830.

Fig. 277, B, c, these larvæ come to present a form D, which reminds us strongly of that of *Daphnia*; the body being

FIG. 277.

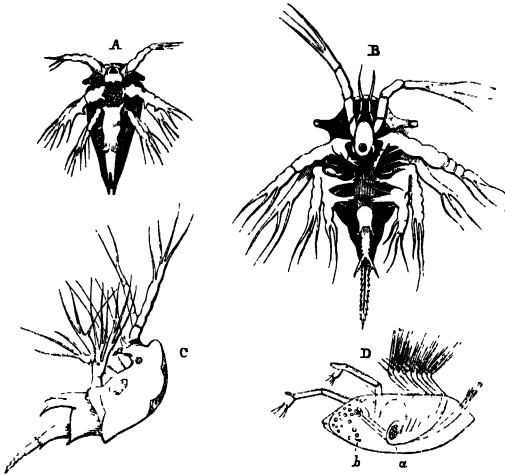

Development of *Balanus balanoides*:—A, earliest form;—B, larva after second moult;—C, side view of the same;—D, stage immediately preceding the loss of activity, a, stomach (?); b, nucleus of future attachment (?).

enclosed in a shell composed of two valves, which are united along the back, whilst they are free along their lower margin, where they separate for the protrusion of a large and strong anterior pair of prehensile limbs provided with an adhesive sucker and hooks, and of six pairs of posterior legs adapted for swimming. This bivalve shell, with the members of both kinds, is subsequently thrown-off; the animal then attaches itself by its head, a portion of which becomes excessively elongated into the 'peduncle' of the Barnacle, whilst in *Balanus* it expands into a broad disk of adhesion; the first thoracic segment sends backwards a prolongation, which arches over the rest of the body so as completely to enclose it, and of which the exterior layer is consolidated into the 'multivalve'

shell; whilst from the other thoracic segments are evolved the six pairs of *cirri*,—which are long, slender, many-jointed, tendril-like appendages, fringed with delicate filaments covered with cilia, whose action serves both to bring food to the mouth, and to maintain aërating currents in the water,—from whose peculiar character the name of the group is derived.

374. The chief points of interest to the Microscopist in the more highly-organized forms of Crustacea, are furnished by the structure of the shell, and by the metamorphoses of the larvæ, both of which may be best studied in the commonest kinds.—The shell of the Decapods in its most complete form consists of three strata; namely, 1, a horny structureless layer covering the exterior; 2, a cellular stratum; and 3, a laminated tubular substance. The innermost and even the middle layers, however, may be altogether wanting; thus in the *Phyllosoma* or ‘glass-crabs,’ the envelope is formed by the transparent horny layer alone; and in many of the small Crabs belonging to the genus *Portuna*, the whole substance of the carapace beneath the horny investment is made-up of hexagonal thick-walled cells. (It may be here noticed, that the carapace of *Daphnia*, *Branchipus*, and some other Entomostraca, exhibits the hexagonal division; whilst in many species this is not distinguishable.) It is in the large thick-shelled Crabs that we find the three layers most differentiated. Thus in the common *Cancer pagurus*, we may easily separate the structureless horny covering after a short maceration in dilute acid; the cellular layer, in which the pigmentary matter of the coloured parts of the shell is contained, may be easily brought into view by grinding-away as flat a piece as can be selected, from the *inner* side, having first cemented the outer surface to the glass slide, and by examining this with a magnifying power of 250 diameters, driving a strong light through it with the achromatic condenser; whilst the tubular structure of the thick inner layer may be readily demonstrated, by means of sections parallel and perpendicular to its surface. This structure, which very strongly resembles that of *dentine* (§ 406), save that the tubuli do not branch, but remain of the same size through their whole course, may be particularly well seen in the black extremity of the claw, which (apparently from some difference in the molecular arrangement of the mineral particles, the organic structure being precisely the same) is much denser than the rest of the shell, the former having almost the semi-transparency of ivory, whilst the latter has a chalky opacity. In a transverse section of the claw, the

tubuli may be seen to radiate from the central cavity towards the surface, so as very strongly to resemble their arrangement in a tooth; and the resemblance is still further increased by the presence, at tolerably-regular intervals, of minute sinuosities corresponding with the laminations of the shell, which seem, like the 'secondary curvatures' of the dentinal tubuli, to indicate successive stages in the calcification of the animal basis. This inner layer rises-up through the pigmentary layer of the Crab's shell, in little papillary elevations; and it is from the deficiency of the pigmentary layer at these parts, that the coloured portion of the shell derives its minutely-speckled appearance.—Many departures from this type are presented by the different species of Decapods; thus in the *Prawns* there are large stellate pigment-cells (resembling those of Fig. 327, *c*), the colours of which are often in remarkable conformity with those of the bottom of the rock-pools frequented by these creatures; whilst in the *Shrimps* there is seldom any distinct trace of the cellular layer, and the calcareous portion of the skeleton is disposed in the form of concentric rings, an approach to which arrangement is seen in the papillæ of the surface of the deepest layer of the Crab's shell.

375. It is a very curious circumstance, that a strongly marked difference exists between Crustaceans that are otherwise very closely allied, in regard to the degree of change to which their young are subject in their progress towards the adult condition. For whilst the common *Crab*, *Lobster*, *Spiny Lobster*, *Prawn*, and *Shrimp* undergo a regular metamorphosis, the young of the *Land-Crab* and the *Cray-fish* come-forth from the egg in a form which corresponds in all essential particulars with that of their parents. Generally speaking, a strong resemblance exists among the young of all the species of Decapods which undergo a metamorphosis, whether they are afterwards to belong to the *brachyurous* (short-tailed) or to the *macrourous* (long-tailed) division of the group; and the forms of these larvæ are so peculiar, and so entirely different from any of those into which they are ultimately to be developed, that they were considered as belonging to a distinct genus, *Zoea*, until their real nature was first ascertained by Mr. J. V. Thompson. Thus, in the earliest state of *Carcinus mænas* (small edible crab), we see the head and thorax, which form

abdominal segments, narrowed and prolonged, carry at the end a flattened tail-fin, by the strokes of which upon the water, the propulsion of the animal is chiefly effected. Its condition is hence comparable, in almost all essential particulars, to that of *Cyclops* (§ 367). In the case of the Lobster, Prawn, and other 'macrourous' species, the metamorphosis

FIG. 278.

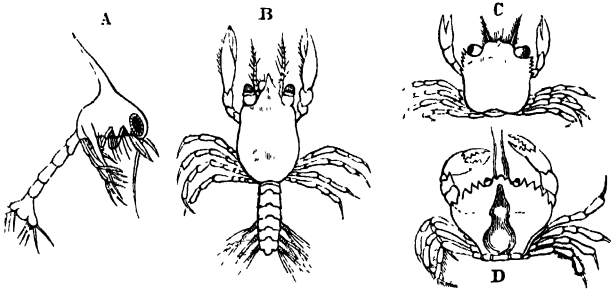

Metamorphosis of *Carcinus maenas*:—A, first stage; B, second stage; C, third stage, in which it begins to assume the adult form, D, perfect form.

chiefly consists in the separation of the locomotive and respiratory functions, true legs being developed from the thoracic segments for the former, and true gills (concealed within a special chamber formed by an extension of the carapace beneath the body) for the latter; and the abdominal segments increase in size, and become furnished with appendages (false feet) of their own. In the Crabs, or 'brachyurous' species, on the other hand, the alteration is much greater; for besides the change first noticed in the thoracic members and respiratory organs, the thoracic region becomes much more developed at the expense of the abdominal, the latter remaining in an almost rudimentary condition, and being bent under the body; the thoracic limbs are more completely adapted for walking, save the first pair, which are developed into *chelæ* or pincers; and the little creature entirely loses the active swimming habits which it originally possessed, and takes on the mode of life peculiar to the adult.—We have, in this history, a most characteristic example of Von Bar's great law of "progress from the general to the special" in organic develop-

ment; for the *Entomostracous* form is thus seen to be common to the highest and the lowest Crustaceans in the earliest phase of their lives; but whilst the latter remain and go on to completion upon that type, the former entirely diverge from it; and whilst diverging from it, they also become differentiated from each other, the distinctive characters of their families, genera, and species, evolving themselves, as the individuals advance towards their mature forms.

376. In collecting minute Crustacea, whether fresh-water or marine, the use of the ring-net, as for minute *Acalephæ* or *Echinoderm-larvæ*, will be found the most efficient instrument; and in favourable localities, the same 'gathering' will often contain multitudes of various species of *Entomostraca*, accompanied, perhaps, by the larvæ of higher Crustacea, by *Echinoderm-larvæ*, by *Annelid-larvæ*, and by the smaller *Medusæ*. The water containing these should be put into a large glass jar freely exposed to the light; and after a little practice, the eye will become so far habituated to the general appearance and modes of movement of these different forms of Animal life, as to be able to distinguish them, one from the other. In selecting any specimen for microscopic examination, the dipping-tube (§ 71) will be found invaluable.—The study of the metamorphoses of the larvæ will be best prosecuted, by obtaining the fertilized eggs which are carried-about by the females, and watching the history of their products.

CHAPTER XVII.

INSECTS AND ARACHNIDA.

THERE is no class in the whole Animal Kingdom which affords to the Microscopist such a wonderful variety of interesting objects, and such facilities for obtaining an almost endless succession of novelties, as that of Insects. For, in the first place, the number of different kinds that may be brought-together (at the proper time) with extremely little trouble, far surpasses that which any other group of Animals can supply to the most pains-taking collector: then, again, each specimen will afford, to him who knows how to employ his materials, a considerable number of microscopic objects of very different kinds; and, thirdly, although some of these objects require much care and dexterity in their preparation, a large proportion may be got-out, examined, and mounted, with very little skill or trouble. Take, for example, the common House-Fly:—its *eyes* may be easily mounted, one as a transparent, the other as an opaque object (§ 383); its *antennæ*, although not such beautiful objects as those of many other Diptera, are still well worth examination (§ 385); its *tongue* or ‘proboscis’ is a peculiarly interesting object (§ 386), though requiring some care in its preparation; its *spiracles*, which may be easily cut-out from the sides of its body, have a very curious structure (§ 392); its alimentary canal affords a very good example of the minute distribution of the ‘tracheæ’ (§ 391); its *wings*, examined on a living specimen, newly come-forth from the pupa state, exhibit the circulation of the blood in the ‘nervures’ (§ 390); the wing of the insect when dead, moreover, exhibits a most beautiful play of iridescent colours, and shows a remarkable areolation of surface, when it is examined by light reflected from its surface at a particular angle (§ 395); its *foot* has a very peculiar conformation, which is doubtless connected with its singular power of walking over smooth surfaces in direct opposition to the force of gravity, although the mode in which it serves this purpose is not yet certainly ascertained (§ 397);

and the structure and-physiology of its sexual apparatus, with the history of its development and metamorphoses, would of itself suffice to occupy the whole time of an observer who should desire thoroughly to work it out, not only for months but for years.—Hence in treating of this department in such a work as the present, the author labours under the *embarras des richesses*; for to enter into such a description of the parts of the structure of Insects most interesting to the Microscopist, as should be at all comparable in fulness with the accounts which it has been thought desirable to give of other classes, would swell-out the volume to an inconvenient bulk; and no course seems open, but to limit the treatment of the subject to a notice of the *kinds* of objects which are likely to prove most generally interesting, with a few illustrations that may serve to make the descriptions more clear, and with an enumeration of some of the sources whence a variety of specimens of each class may be most readily obtained. And thus limitation is the less to be regretted, since there already exist in our language numerous elementary treatises on Entomology, wherein the general structure of Insects is fully explained, and the conformation of their minute parts as seen with the Microscope is adequately illustrated.

377. A considerable number of the smaller Insects,—especially those belonging to the orders *Coleoptera* (beetles), *Neuroptera* (dragon-fly, may-fly, &c.), *Hymenoptera* (bee, wasp, &c.), and *Diptera* (two-winged flies), may be mounted entire as opaque objects for low magnifying powers; care being taken to spread-out their legs, wings, &c., so as adequately to display them, which may be accomplished even after they have dried in other positions, by softening them by steeping them in hot water, or, where this is objectionable, by exposing them to steam. Full directions on this point, applicable to small and large Insects alike, will be found in all text-books of Entomology. There are some, however, whose translucency allows them to be viewed as transparent objects; and these are either to be mounted in Canada balsam, or in weak spirit or glycerine, according to the degree in which the horny opacity of their integument requires the assistance of the former to facilitate the transmission of light through it, or the softness and delicacy of their textures renders a preservative liquid more desirable. Thus an ordinary *Flea* or *Bug* will best be mounted in the former medium; but the various parasites of the *Louse* kind, with some or other of which almost every kind of animal is affected, should be set-up

in the latter. Some of the aquatic larvæ of the Diptera and Neuroptera, which are so transparent that their whole internal organization can be made-out without dissection, are very beautiful and interesting objects, when examined in the living state, especially because they allow the circulation of the blood and the action of the dorsal vessel to be discerned (§ 389). Among these, there is none preferable to the larva of the *Ephemera marginata* (day-fly), which is distinguished by the possession of a number of beautiful appendages on its body and tail, and is, moreover, an extremely common inhabitant of our ponds and streams. This insect passes two or even three years in its larva state, and during this time it repeatedly throws-off its skin; the cast-skin, when perfect, is an object of extreme beauty, since, as it formed a complete sheath to the various appendages of the body and tail, it continues to exhibit their outlines with the utmost delicacy; and by keeping these larvæ in a Vivarium, and by mounting the entire series of their cast skins, a record is preserved of the successive changes they undergo. Much care is necessary, however, to extend them upon their slides, in consequence of their extreme fragility; and the best plan is to place the slip of glass under the skin whilst it is floating on water, and to lift the object out upon the slide.

378. *Structure of the Integument.*—In treating of the separate parts of the organisation of Insects, which furnish the most interesting objects of Microscopic study, we may most appropriately commence with their integument and its appendages (scales, hairs, &c.). The body and members are closely invested by a hardened skin, which acts as their skeleton, and affords points of attachment to the muscles by which their several parts are moved; being soft and flexible, however, at the joints. This skin is usually more or less horny in its texture, and is consolidated by the animal substance termed *chiline*, as well as, in some cases, by a small quantity of mineral matter. It is in the Colcoptera that it attains its greatest development; the dermo-skeleton of many beetles being so firm, as not only to confer upon them an extraordinary power of passive resistance, but also to enable them to put-forth enormous force, by the action of the powerful muscles which are attached to it. It may be stated as a general rule, that the external layer of this dermo-skeleton is always cellular, taking the place of an epidermis; and that the cells are straight-sided and closely fitted-together, so as to be polygonal (usually hexagonal) in form. Of this

we have a very good example in the *superficial* layers (Fig. 286, B) of the thin horny lamellæ or blades, which constitute the terminal portion of the antenna of the *Cockchaffer* (Fig. 285); this layer being easily distinguished from the intermediate portion of the lamina (A), by careful focussing. In many beetles, the hexagonal arcolation of the surface is often distinguishable when the light is reflected from it at a particular angle, even when not discernible in transparent sections. The integument of the common *Red Ant* exhibits the hexagonal cellular arrangement very distinctly throughout; and the broad flat expansion on the leg of the *Crabro* (sand-wasp) affords another beautiful example of a distinctly-cellular structure in the outer layer of the integument. The inner layer, however, which constitutes the principal part of the thickness of the horny casing of the Beetle-tribe, seldom exhibits any distinct organisation; though it may be usually separated into several laminae, which are sometimes traversed by tubes that pass into them from the inner surface, and extend towards the outer without reaching it. Occasionally, however, even this exhibits very clear indications of cellular structure; of which a good example is afforded by the *middle* layer of the lamellæ of the antenna of the *Cockchaffer* (Fig. 286, A), wherein is plainly to be seen an assemblage of rounded cells with large nuclei, lying in the midst of a homogeneous intercellular substance, and thus closely resembling Cartilage (Fig. 324) in structure, though differing from it in chemical composition.

379. *Tegumentary Appendages*.—The surface of many Insects is beset, and is sometimes completely covered, with *appendages*, having sometimes the form of broad flat scales, sometimes that of hairs more or less approaching the cylindrical shape, and sometimes being intermediate between the two.—The *scaly* investment is most complete among the *Lepidoptera* (butterfly and moth tribe); the distinguishing character of the insects of this order being derived from the presence of a regular layer of scales, upon each side of their large membranous wings. It is to the peculiar coloration of the scales, that the various hues and figures are due, by which these wings are so commonly distinguished; all the scales of one patch (for example) being green, those of another red, and so on; for the subjacent membrane remains perfectly transparent and colourless, when the scales have been brushed-off from its surface. Each scale seems to be composed of two superficial coloured laminae, inclosing a central

lamina of structureless membrane, the surface of which is highly polished, and which acts as a 'foil' to increase their brilliancy by reflecting-back the light that passes through them,—an arrangement which may often be discerned in scales that have lost a portion of their superficial layer by some accidental injury (Fig. 281, c). The colour of the superficial laminae seems to be generally inherent in their substance, especially in the Lepidoptera; but it sometimes appears to be (like the prismatic hues of a soap-bubble) a purely-optical effect of their extreme thinness, this being especially the case among those beetles, as the *Curculio imperialis* (diamond-beetle), the scales of which have a metallic lustre, and exhibit colours that vary with the mode in which the light glances from them. Each scale is furnished with a sort of handle at one end (Figs. 279–281), by which it is fitted into a minute socket attached to the surface of the insect; and on the wings of Lepidoptera these sockets are so arranged, that the scales lie in very regular rows, each row overlapping a portion of the next, so as to give to their surface, when sufficiently magnified, very much the appearance of being *tiled* like the roof of a house. Such an arrangement is said to be 'imbricated.' The forms of these scales are often very curious, and frequently differ a good deal on the several parts of the wings and of the body of the same individual; being usually more expanded on the former, and narrower and more hair-like on the latter. The peculiar markings which many of these scales exhibit, very early attracted the attention of those engaged in the improvement of the Microscope by the application of the principle of achromatic correction (p. 10); since these markings are entirely invisible, however great may be the magnifying power employed, under microscopes of the older construction, owing to the necessary limitation of their angular aperture; whilst, as they are brought into view with a clearness and strength that are proportionate to the extension of the angular aperture and the perfection with which the aberrations are corrected, they serve as 'test objects' of the goodness of an achromatic combination. At first, the scale of the *Podura* (Fig. 281) was the most difficult test known for the *highest* powers; and a microscope which could only exhibit an alternation of dark and light bands or striæ upon its surface, was considered a good one. But even the complete 'resolution' of these striæ into their component markings, is now considered as but a very ordinary 'test' for the *medium* powers of the Microscope; and tests of much greater difficulty,

and therefore more suitable for the higher, are afforded (as we have seen, § 102, III.) by the valves of the Diatomaceæ. Still, the test-scales of Insects have their use, in enabling us to appreciate the performance of achromatics of *medium* power (§ 102, III.); and it will therefore be advantageous here to notice a few of those which are most commonly employed for this purpose.

380. Among the most beautiful of all these scales, both for colour and for regularity of marking, are those of the butterfly termed *Morpho Menelaus* (Fig. 279). These are of a rich blue tint, and exhibit strong longitudinal striæ, which

FIG. 279.

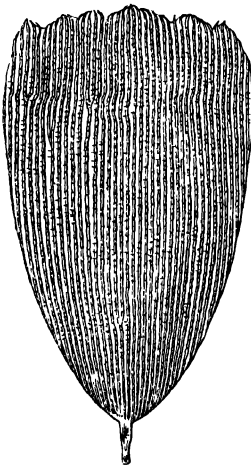

Scale of *Morpho Menelaus*.

seem due to ribbed elevations of the superficial coloured layer. There is also an appearance of transverse striation, which cannot be seen at all with an inferior objective, becomes very decided with a good objective of medium focus, but is found, when submitted to the test of a high power and achromatic condenser, to depend upon a sort of beaded subdivision of the longitudinal ribs,—the transverse striæ that may be seen *between* these ribs, being apparently produced by the beading of the ribs on the other surface of the scale.—The large scales of the *Polyommatus argus* (azure-blue butterfly) resemble those of the *Menelaus* in form and structure, but are more

delicately marked. The same insect, however, furnishes small scales, which are commonly termed the 'battledoor' scales, the resemblance which their form presents to that instrument being usually much greater than in the specimen represented in Fig. 280; these scales, also, are marked by narrow longitudinal ribbings, which at intervals expand into rounded or oval elevations, that give to the scale a dotted appearance; at the lower part of the scale, however,

these dots are wanting; and in the interval between the two portions, we observe a sort of crescent, formed of minute pigment-granules, crossing the scale transversely.—The scales of the *Pontia brassica* (cabbage butterfly) and of the *Hipparchia janira* (meadow-brown butterfly), have longitudinal markings of a somewhat similar nature, but less sharply defined: these are further noticeable for the brush-like appendage which each scale bears at the end furthest from its implantation.—The *Podura plumbea* or 'spring-tail' is a little wingless insect that is found amidst the sawdust of many wine-cellar, especially such as are damp, leaping-about like a flea, by means of that peculiar power of using its tail, from which its name is derived. Its scales are of different sizes and of different degrees of strength of marking (Fig. 281, A, B), and are therefore by no means of uniform value as tests. The general appearance of their surface, under a power not sufficient to resolve their marking, is that of watered silk, light and dark bands passing-across with wavy irregularity; but a well-corrected lens of very moderate angular aperture, now suffices to resolve every dark band into a row of short lines, each of these being thick at one end and coming to a point at the other, so that the impression conveyed is that of a set of spines projecting obliquely from the flat surface of the scale, like the teeth of a 'hackle.' A more careful examination of scales, however, of which the superficial layers have been partly removed (c), serves to show that these dark lines are but the spaces between the minute wedge-like particles, arranged side-by-side, and end-to-end, of which those layers are made-up; so that the structure of the scale does not in reality differ essentially from the ordinary type.*—Although

FIG. 280

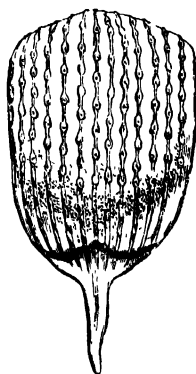

Battledoor Scale of
Polyommatus argus
(azure-blue).

* *Podurae* may be obtained by sprinkling a little oatmeal on a piece of black paper near their haunts; and after leaving it there for a few hours, removing it carefully to a large glazed basin, so that, when they leap from the paper (as they will when brought to the light) they may fall into the basin, and may thus separate themselves from the meal. The best way of

scarcely useful as a 'test-object,' since its structure is too easily resolved, the scale of the *Lepisma saccharina* or 'sugar-louse' deserves notice;

FIG. 281.

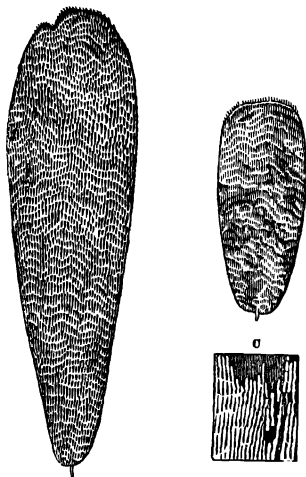

Scales of *Podura plumbea*:—A, large strongly-marked scale; B, small scale, more faintly-marked; C, portion of an injured scale, showing the nature of the markings.

hair of the *Bee* is pretty sure to exhibit strong prismatic colours, if the chromatic aberration should not have been exactly neutralized; and that of the larva of the *Dermestes*, or 'bacon-beetle,' was once thought a very good test of defining power, and is still useful for this purpose. It has a cylindrical shaft (Fig. 282, B) with closely-set whorls of spiny protuberances, four or five in each whorl; the highest of these whorls is composed of more knobly spines; and the hair is

obtaining their scales, is to confine several of them together beneath a wine-glass inverted upon a piece of fine smooth paper for the scales will be detached by their leaps against the glass, and will fall upon the paper; and if they be left thus confined for some time, they will be very likely, by treading upon some of the scales, to bring them into the condition represented at C, Fig. 281, which best illustrates their true nature.

being so strongly marked and so regular, as to give them an appearance resembling that of many bivalve shells. The long narrow scale of the common *Gnat*, also, exhibits a few very prominent ribbings; and, from its small size, it serves as a good test-object for the medium powers.

381. The *Hairs* of many Insects, and still more of their larvæ, are very interesting objects for the microscope, on account of their branched or tufted conformation; this being particularly remarkable in those with which the common hairy Caterpillars are so abundantly beset. Some of these afford very good tests for the perfect correction of objectives. Thus, the

surmounted by a curious circle of six or seven large filaments, attached by their pointed ends to its shaft, whilst at their free extremities they dilate into knobs. An approach to this structure is seen in the hairs of certain *Myriapods* (centipedes, gally-worms, &c.), of which an example is shown in Fig. 282, A.

FIG. 282.

A B

382. In examining the integument of Insects, and its appendages, parts of the surface may be viewed either by reflected or transmitted light, according to their degree of transparency and the nature of their covering. The Beetle and Butterfly tribes furnish the greater number of the objects suitable to be viewed in the former of these modes; and nothing is easier than to mount portions of the *elytra* of the former (which are usually the most showy portions of their bodies), or of the wings of the latter, in the manner described in § 123. The tribe of *Curculionidæ*, in which the surface of the body is beset with scales having the most varied and lustrous hues, is distinguished among all other Coleoptera for the brilliancy of the objects it affords; the most remarkable in this respect being the well-known *Curculio imperialis*, or

A, Hair of *Myriapod*.
B, Hair of *Dermestes*.

‘diamond beetle’ of South America, parts of whose *elytra*, when properly illuminated and looked-at with a low power, show like clusters of jewels flashing against a dark velvet ground. In many of the British *Curculionidæ*, which are smaller and far less brilliant, the scales lie at the bottom of little depressions of the surface; and if the *elytra* of the ‘diamond beetle’ be carefully examined, it will be found that each of the clusters of scales which are arranged upon it in rows, seems to rise out of a deep pit which sinks-in by its side. The transition from scales to hairs is extremely well seen, by comparing the different parts of the surface of the ‘diamond beetle’ with each other. The beauty and brilliancy

of many objects of this kind are increased by mounting them in cells in Canada balsam, even though they are to be viewed with reflected light; other objects, however, are rendered less attractive by this treatment; and in order to ascertain whether it is likely to improve or to deteriorate the specimen, it is a good plan first to test some other portion of the body, having scales of the same kind, by touching it with turpentine, and then to mount the part selected as an object, either in balsam, or dry, according as the turpentine increases or diminishes the brilliancy of the scales on the spot to which it was applied. Portions of the wings of Lepidoptera are best mounted as opaque objects, without any other preparation than gumming them flat down to the card-board surface of the slide (§ 123); care being taken to avoid disturbing the arrangement of the scales, and to keep the objects, when mounted, as secluded as possible from dust. In selecting such portions, it is well to choose those which have the brightest and the most contrasted colours, foreign butterflies being in this respect usually preferable to British; and before attaching them to their slides, care should be taken to ascertain in what position, with the arrangement of light ordinarily used, they are seen to the best advantage, and to fix them there accordingly.—Whenever portions of the integument of Insects are to be viewed as transparent objects, for the display of their intimate structure, they should be mounted in Canada balsam, after soaking for some time in turpentine; since this substance has a peculiar effect in increasing their translucency. Not only the horny casings of perfect Insects of various orders, but also those of their pupæ, are worthy of this kind of study; and objects of great beauty (such as the chrysalis-case of the Emperor-moth), as well as of scientific interest, are sure to reward any who may prosecute it with any assiduity. Further information may often be gained, by softening such parts in potash, and viewing them in fluid.—The *scales* of the wings of Lepidoptera, &c., are best transferred to the slide, by simply pressing a portion of the wing either upon the slip of glass or upon the cover; if none should adhere, the glass may first be gently breathed-on. Some of them are best seen when examined 'dry,' whilst others are more clear when mounted in fluid; and for the determination of their exact structure, it is well to have recourse to both these methods. If these scales are to be used as 'test-objects,' it is preferable to place them between two pieces of thin glass, in the manner specified in § 122. Hairs, on the other hand, are best mounted in balsam.

383. *Parts of the Head.*—The *Eyes* of Insects, situated upon the upper and outer part of the head, are usually very conspicuous organs, and are frequently so large as to touch each other in front (Fig. 283). We find in their structure a remarkable example of that multiplication of similar parts, which seems to be the predominating idea in the conformation of Articulated animals; for each of the large protuberant bodies which we designate as *an eye*, is really an aggregate of many hundred, or even many thousand minute eyes, which are designated *ocelli*. Approaches to this structure are seen in the Annelida and Entomostraca; but the number of 'ocelli' thus grouped-together is usually small. In the higher Crustacea, however, the ocelli are very numerous; their compound eyes being constructed upon the same general plan as those of Insects, although their shape and position are often very peculiar (Fig. 343). The individual ocelli are at once recognized, when the composite eyes are examined under even a low magnifying power, by the 'facetted' appearance of the surface (Fig. 283), which is marked-out by very regular divisions either into hexagons or into squares: each facet is the cornea of a separate ocellus, and has a convexity of its own; hence by counting the facets, we can ascertain the number of ocelli in each composite eye. In the two eyes of the common *Fly*, there are as many as 4000; in those of the *Cabbage-Butterfly*, there are about 17,000; in the *Dragon-fly*, 24,000; and in the *Mordella beetle*, 25,000. Behind each 'corneule' is a layer of dark pigment, which takes the place, and serves the purpose, of the 'iris' in the eyes of Vertebrate animals; and this is perforated by a central aperture or 'pupil,' through which the rays of light that have traversed the cornea

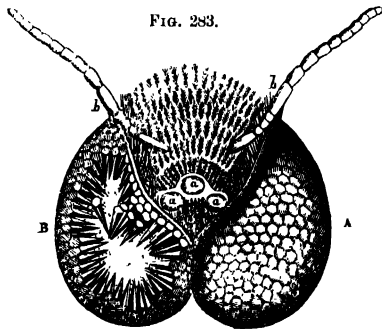

Head and Compound Eyes of the *Bee*, showing the ocelli *in situ* on one side (A), and displaced on the other (B); a, a, a, stemmata; b, b, antennæ.

and this is perforated by a central aperture or 'pupil,' through which the rays of light that have traversed the cornea

gain access to the interior of the eye. The further structure of these bodies is best examined by vertical sections; and these show that the shape of each ocellus is conical, or rather pyramidal (Fig. 284), the cornea forming its base (*a*), whilst its apex abuts upon a bulbous expansion of the optic nerve.

FIG. 284.

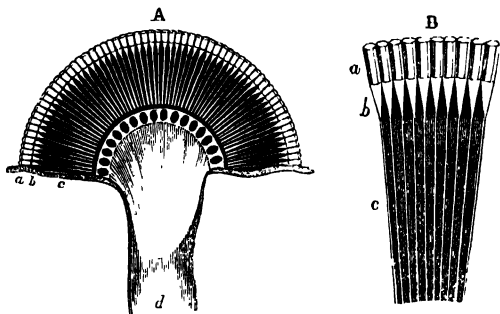

A, Section of the eye of *Melolontha vulgaris* (Cockchafer):—*b*, a portion more highly magnified —*a*, facets of the cornea; *b*, transparent pyramids surrounded with pigment; *c*, fibres of the optic nerve, *d*, trunk of the optic nerve.

Each 'corneule' acts as a distinct lens; as may be shown by detaching the entire assemblage by maceration, and then drying it (flattened-out) upon a slip of glass; for when this is placed under the microscope, if the point of a knife, scissors, or any similar object, be interposed between the mirror and the stage, the image of this point will be seen, by a proper adjustment of the focus of the microscope, in every one of the lenses. The focus of each 'corneule' has been ascertained by experiment to be equivalent to the length of the pyramid behind it; so that the image which it produces will fall upon the extremity of the filament of the optic nerve which passes to its point. This pyramid consists of a transparent substance (*b*, *b*), which may be considered as representing the 'vitreous humor;' and the pyramids are separated from each other by a layer of dark pigment, which completely encloses them, save at the pupillary apertures which admit the rays that have passed through the 'corneules,' and at their smaller ends, where the pigment is perforated by a set of apertures that give passage to the fibres of the optic

nerve (*c*), of which one proceeds to each ocellus. Thus the rays which have passed through the several 'corneules' are prevented from mixing with each other; and no rays save those which pass in the axis of the pyramids, can reach the fibres of the optic nerve. Hence it is evident that, as no two ocelli on the same side have exactly the same axis, no two can receive their rays from the same point of an object; and thus, as each composite eye is immovably fixed upon the head, the combined action of the entire aggregate will probably only afford but a single image, resembling that which we obtain by means of our single eyes.—Although the foregoing may be considered as the typical structure of the eyes of Insects, yet there are various departures from it (most of them slight) in the different members of the class. Thus in some cases the posterior surface of each 'corneule' is concave; and a space is left between it and the iris-like diaphragm, which seems to be occupied by a watery fluid or 'aqueous humor'; in other instances, again, this space is occupied by a double-convex body, which seems to represent the 'crystalline lens;' and this body is sometimes found behind the iris, the number of ocelli being reduced, and each one being larger, so that the cluster presents more resemblance to that of Spiders, &c.—Besides their composite eyes, Insects usually possess a small number of rudimentary single eyes, resembling those of the Arachnida; these are seated upon the top of the head, and are termed *stemmata* (Fig. 283, *a, a, a*).—It is remarkable that the *larvæ* of Insects which undergo a complete metamorphosis, only possess single eyes; the composite eyes being developed, at the same time with the wings and other parts which are characteristic of the Imago state, during the latter part of Pupal life.

384. Various modes of preparing and mounting the Eyes of Insects may be adopted, according to the manner wherein they are to be viewed. For the observation of their external faceted surface by reflected light, it is better to lay-down the entire head, so as to present a front-face or a side-face, according to the position of the eyes; the former giving a view of *both* eyes, when they approach each other so as nearly or quite to meet (as in Fig. 283); whilst the latter will best display *one*, when the eyes are situated more at the sides of the head. For the minuter examination of the 'corneules,' however, these must be separated from the hemispheroidal mass whose exterior they form, by prolonged maceration; and the pigment must be carefully washed-away by means of

a fine camel-hair brush, from their inner or posterior surface. In flattening them out upon the glass-slide, one of two things must necessarily happen; either the margin must tear when the central portion is pressed-down to a level; or, the margin remaining entire, the central portion must be thrown into plaits, so that its corneules overlap one another. As the latter condition interferes with the examination of the structure much more than the former does, it should be avoided by making a number of slits in the margin of the convex membrane before it is flattened-out. Such preparations may be mounted either in liquid, or in Canada balsam; the latter being preferable when (as sometimes happens) the membrane is so horny as to be but imperfectly transparent. Vertical sections, adapted to demonstrate the structure of the ocelli and their relations to the optic nerve, can of course be only made when the body of the insect is fresh; and these should be mounted in fluid. The following are some of the Insects, whose eyes are best adapted for Microscopic preparations:—*Coleoptera*, Cicindela, Dytiscus, Melolontha (cockchafer), Lucanus (stag-beetle); *Orthoptera*, Acheta (house and field crickets), Locusta; *Hemiptera*, Notonecta (boat-fly); *Neuroptera*, Libellula (dragon-fly), Agrion; *Hymenoptera*, Vespidae (wasps) and Apidae (bees) of all kinds; *Lepidoptera*, Vanessa (various species of butterflies), Sphinx ligustri (privet hawk-moth), Bombyx (silkworm-moth, and its allies); *Diptera*, Tabanus (gad-fly), Asilus, Eristalis (drone-fly), Tipula (crane-fly), Musca (house-fly), and many others.

385. The *Antennæ*, which are the two jointed appendages arising from the upper part of the head of Insects (Fig. 283, *b, b*), present a most wonderful variety of conformation in the several tribes of Insects; often differing considerably in the several species of one genus, and even in the two sexes of the same species. Hence the characters which they afford are extremely useful in classification; especially since their structure must almost necessarily be in some way related to the habits and general economy of the creatures to which they belong (although our imperfect acquaintance with their function prevents us from clearly discerning this relation), so that their resemblances and differences will generally be found to coincide with those resemblances and differences in general conformation, on which every 'natural' arrangement must be founded. Thus, in the Coleopterous order, we find one large family, including the glow-worm, fire-fly, skip-jack, &c., distinguished by the toothed or serrated form of the antennæ,

and hence called *Serricornes*; in another, of which the 'burying-beetle' is the type, the antennæ are terminated by a club-shaped enlargement, so that these beetles are termed *Clavicornes*; in another, again, of which the *Hydrophilus* or 'large water-beetle' is an example, the antennæ are never longer and are commonly shorter than one of the pairs of palpi, whence the name of *Palpicornes* is given to this group; in the very large family that includes the *Lucani* or 'stag-beetles,' with the *Scarabæi* of which the 'cockchafer' is the commonest example, the antennæ terminate in a set of leaf-like appendages, which are sometimes arranged like a fan or the leaves of an open book (Fig. 285), are sometimes parallel to each other like the teeth of a comb, and sometimes fold one over the other, thence giving the name *Lamellicornes*; whilst another large family is distinguished by the appellation *Longicornes*, from the great length of the antennæ, which are at least as long as the body, and often longer. Among the *Lepidoptera*, again, the conformation of the antennæ frequently enables us at once to distinguish the group to which any specimen belongs. As every treatise on Entomology contains figures and descriptions of the principal types of conformation of

FIG. 285

Antenna of *Melolontha* (Cockchafer).

these organs, there is no occasion here to dwell upon them longer than to specify such as are most interesting to the Microscopist:—*Coleoptera*, *Brachinus*, *Calathus*, *Harpalus*, *Dytiscus*, *Staphylinus*, *Philonthus*, *Elater*, *Lampyris*, *Silpha*,

Hydrophilus, Aphodius, Melolontha, Cetonina, Curculio; *Orthoptera*, Forficula (carwig), Blatta (cockroach); *Lepidoptera*,

FIG. 296.

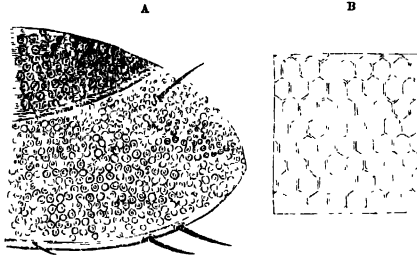

Minute structure of Leaf-like expansions of Antenna of *Melolontha*:—
A, their internal layer; B, their superficial layer.

Sphinges (hawk-mot's) and Nocturna (moths) of various kinds, the large 'plumed' antennæ of the latter being peculiarly beautiful objects under a low magnifying power; *Diptera*, Culicidæ (gnats of various kinds), Tipulidæ (crane-flies and midges), Tabanus, Eristalis, and Muscidæ (flies of various kinds). All the larger antennæ should be put-up in balsam, after being soaked for some time in turpentine; but the small feathery antennæ of gnats and midges are so liable to distortion when thus mounted, that it is better to set them up in fluid, the head with its pair of antennæ being thus preserved together when not too large.

386. The next point in the organization of Insects, to which the attention of the Microscopist may be directed, is the structure of the *Mouth*. Here, again, we find almost infinite varieties in the details of conformation; but these may be for the most part reduced to a small number of types or plans, which are characteristic of the different orders of Insects. It is among the *Coleoptera*, or beetles, that we find the several parts of which the mouth is composed, in their most distinct form; for although some of these parts are much more highly developed in other insects, other parts may be so much altered or so little developed, as to be scarcely recognizable. The *Coleoptera* present the typical conformation of the *mandibulate* mouth, which is adapted for the prehension and division of solid substances; and this consists of the following parts:—1. A pair of jaws, termed *mandibles*,

frequently furnished with powerful teeth, opening laterally on either side of the mouth, and serving as the chief instruments of manducation; 2. A second pair of jaws, termed *maxillæ*, smaller and weaker than the preceding, beneath which they are placed, and serving to hold the food, and to convey it to the back of the mouth; 3, an upper lip, or *labrum*; 4, a lower lip, or *labium*; 5, one or two pairs of small jointed appendages termed palpi, attached to the maxillæ, and hence called *maxillary palpi*; 6, a pair of *labial palpi*. The labium

FIG. 287.

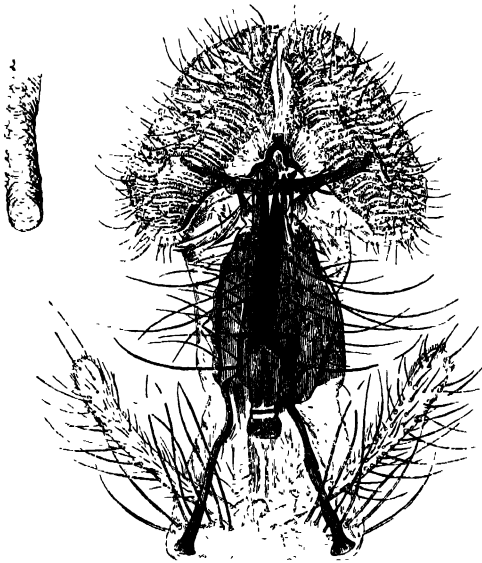

Tongue of common *Fly*:—*a*, lobes of ligula; *b*, portion enclosing the lancets formed by the metamorphosis of the maxilla; *c*, maxillary palpi.—*A*, portion of one of the metamorphosed tracheæ enlarged.

is often composed of several distinct parts; its basal portion being distinguished as the *mentum* or chin, and its anterior portion being sometimes considerably prolonged forwards, so as to form an organ which is properly designated the *ligula*, but

which is more commonly known as the 'tongue,' though not really entitled to that designation, the real *tongue* being a soft and projecting organ that forms the floor of the mouth, and being only found as a distinct part in a comparatively small number of insects, as the Cricket.—This ligula is extremely developed in the *Fly* kind, in which it forms the chief part of what is commonly called the 'proboscis' (Fig. 287); and it also forms the 'tongue' of the *Bee* and its allies (Fig. 288). In the *Diptera* or two-winged flies generally, the labrum, maxillæ, mandibles, and the internal tongue (where it exists) are converted into delicate lancet-shaped organs termed *setæ*, which, when closed-together, are received into a hollow on the

FIG. 288.

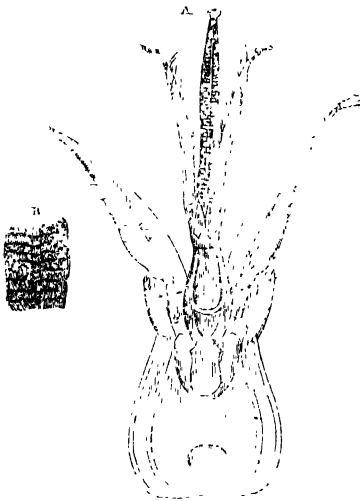

A, Parts of the mouth of *Apis mellifica* (Honey-bee):—*a*, mentum; *b*, mandibles; *c*, maxilla; *d*, labial palpi; *e*, ligula, or prolonged labium, commonly termed the tongue:—B, portion of the surface of the ligula, more highly magnified.

upper side of the labium (Fig. 287, *b*), but which are capable of being used to make punctures in the skin of animals or the epidermis of plants, whence the juices may be drawn-forth by the proboscis. Frequently, however, two or more of these organs may be wanting, so that their number is reduced from six, to four, three, or two.

—In the *Hymenoptera* (bee and wasp-tribe), however, the labrum and the mandibles (Fig. 288, *b*), much resemble those of mandibulate insects, and are used for corresponding purposes; the maxillæ (*c*) are greatly elongated,

and form, when closed, a tubular sheath for the *ligula* or 'tongue,' through which the honey is drawn up; the labial

palpi (*d*) also are greatly developed, and fold-together like the maxillæ, so as to form an inner sheath for the 'tongue;' while the 'ligula' itself (*e*) is a long tapering muscular organ, marked by an immense number of short annular divisions, and densely covered over its whole length with long hairs (*b*). It is not tubular, as some have stated, but is solid; when actively employed in taking food, it is extended to a great distance beyond the other parts of the mouth; but when at rest, it is closely packed-up and concealed between the maxillæ. "The manner," says Mr. Newport, "in which the honey is obtained when the organ is plunged into it at the bottom of a flower, is by 'lapping,' or a constant succession of short and quick extensions and contractions of the organ, which occasion the fluid to accumulate upon it and to ascend along its upper surface, until it reaches the orifice of the tube formed by the approximation of the maxillæ above, and of the labial palpi and this part of the ligula below."

387. By the plan of conformation just described, we are led to that which prevails among the Lepidoptera or butterfly tribe, and which, being pre-eminently adapted for suction, is termed the *haustellate* mouth. In these insects, the labrum and mandibles are reduced to three minute triangular plates; whilst the maxillæ are immensely elongated, and are united together along the median line, to form the *haustellium* or proboscis, which contains a tube formed by the junction of the two grooves that are channelled-out along their mutually applied surfaces, and which serves to pump-up the juices of deep cup-shaped flowers, into which the size of their wings prevents these insects from entering. The length of this *haustellium* varies greatly: thus in such Lepidoptera as take no food in their perfect state, it is a very insignificant organ; in some of the white Hawk-moths, which hover over blossoms without alighting, it is nearly two inches in length; and in most Butterflies and Moths it is about as long as the body itself. This *haustellium*, which, when not in use, is coiled-up in a spiral beneath the mouth, is an extremely beautiful microscopic object, owing to the peculiar banded arrangement it exhibits (Fig. 289), which is probably due to the disposition of its muscles. In many instances, the two halves may be seen to be locked-together by a set of hooked teeth, which are inserted into little depressions between the teeth of the opposite side. Each half, moreover, may be ascertained to contain a trachea or air-tube (§ 391); and it is

probable, from the observations of Mr. Newport,* that the sucking-up of the juices of a flower through the haustellium

FIG. 289.

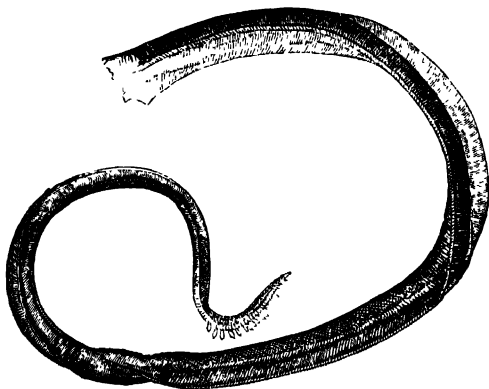
Haustellium (proboscis) of *Vanessa*.

(which is accomplished with great rapidity) is effected by the agency of the respiratory apparatus. The proboscis of many Butterflies is furnished, for some distance from its extremity, with a double row of small projecting barrel-shaped bodies (shown in Fig. 289), which are surmised by Mr. Newport to be organs of taste.—Numerous other modifications of the structure of the mouth, existing in the different tribes of Insects, are well worthy of the careful study of the Microscopist; but as detailed descriptions of most of these will be found in every systematic treatise on Entomology, the foregoing general account of the principal types must suffice.

388. *Parts of the Body.*—The conformation of the several divisions of the *Alimentary Canal* presents such a multitude of diversities, not only in different tribes of Insects, but in different states of the same individual, that it would be utterly vain to attempt here to give even a general idea of it; more especially as it is a subject of far less interest to the ordinary Microscopist, than it is to the professed Anatomist. Hence we shall only stop to mention, that the muscular gizzard in which

* "Cyclopædia of Anatomy and Physiology," vol. ii., p. 902.

the œsophagus very commonly terminates, is often lined by several rows of strong horny teeth for the reduction of the food, which furnish very beautiful microscopic objects. These are particularly developed among the Grasshoppers, Crickets, and Locusts, the nature of whose food causes them to require powerful instruments for its reduction.

389. The *Circulation of Blood* may be distinctly watched in many of the more transparent *Larvæ*, and may sometimes be observed in the perfect Insect. It is kept-up, not by an ordinary heart, but by a 'dorsal vessel,' which really consists of a succession of muscular hearts or contractile cavities, one for each segment, opening one into another from behind forwards, so as to form a continuous trunk divided by valvular partitions. In many larvæ, however, these partitions are very indistinct, and the walls of the 'dorsal vessel' (so named from the position it always occupies along the middle of the back) are so thin and transparent that it can with difficulty be made out, a limitation of the light by the diaphragm being often necessary. The blood which moves through this trunk, and which is distributed by it to the body, is a transparent and nearly-colourless fluid, carrying with it a number of 'oat-shaped' corpuscles, by the motion of which its flow can be followed. The current enters the dorsal vessel at its posterior extremity, and is propelled by the contractions of the successive chambers towards the head, being prevented from moving in the opposite direction by the valves between the chambers, which only open forwards. Arrived at the anterior extremity of the dorsal vessel, the blood is distributed in three principal channels; a central one, namely, passing to the head, and a lateral one to either side, descending so as to approach the lower surface of the body. It is from the two lateral currents that the secondary streams diverge, which pass into the legs and wings, and then return back to the main stream; and it is from these also, that, in the larva of the *Ephemera marginata* (day-fly), the extreme transparency of which renders it one of the best of all subjects for the observation of Insect circulation, the smaller currents diverge into the gill-like appendages with which the body is furnished (§ 393). The blood-currents seem rather to pass through channels excavated among the tissues, than through vessels with distinct walls; but it is not improbable that in the perfect Insect the case may be different. In many aquatic larvæ, especially those of the *Culicidæ* (gnat tribe), the body is almost entirely occupied by the visceral cavity; and the blood may be seen

to move backwards in the space that surrounds the alimentary canal, which here serves the purpose of the channels usually excavated through the solid tissues, and which freely communicates at each end with the dorsal vessel. This condition strongly resembles that found in many Annelida. In some larvæ, whose development is yet less advanced, even the dorsal vessel appears to be wanting, although the fluid of the visceral cavity (in which corpuseles abound) is in a state of continual oscillatory movement.

390. The Circulation may be easily seen in the wings of many insects in their *Pupa* state, especially in those of the Neuropterous order (such as dragon-flies and day-flies) which pass this part of their lives in water, in a condition of activity; the pupa of *Agrion puella*, one of the smaller dragon-flies, is a particularly favourable subject for such observations. Each of the 'nerves' of the wings contains a 'trachea' or air-tube (§ 391), which branches-off from the tracheal system of the body; and it is in a space around the trachea that the blood may be seen to move, when the hard framework of the nerve itself is not too opaque. The same may be seen, however, in the wings of pupæ of Bees, Butterflies, &c., which remain shut-up motionless in their cases; for this condition of apparent torpor is one of great activity of their nutritive system, those organs, especially, which are peculiar to the perfect insect, being then in a state of rapid growth, and having a vigorous circulation of blood through them. In certain Insects of nearly every order, a movement of fluid has been seen in the wings for some little time after their last metamorphosis; but this movement soon ceases, and the wings dry-up. The common *Fly* is as good a subject for this observation, as can be easily found; it must be caught within a few hours or days of its first appearance; and the circulation may be most conveniently brought into view, by enclosing it (without water) in the animalcule-cage, and pressing-down the cover sufficiently to keep the body at rest, without doing it any injury.

391. The *Respiratory Apparatus* of Insects affords a very interesting series of microscopic objects; for, with great uniformity in its general plan, there is almost infinite variety in its details. The aeration of the blood in this class is provided-for, not by the transmission of the fluid to any special organ representing the *lung* of a Vertebrated animal (§ 438) or the *gill* of a Mollusk (§ 353), but by the introduction of air into every part of the body, through a system of minutely-

distributed *tracheæ* or air-tubes, which penetrate even the smallest and most delicate organs. Thus, as we have seen, they pass into the *haustellium* or 'proboscis' of the Butterfly (§ 386), and they are minutely distributed in the elongated *labium* or 'tongue' of the fly (Fig. 287). Their general distribution is shown in Fig. 290; where we see two long trunks (*f*) passing from one end of the body to the other, and connected with each other by a transverse canal in every segment; these trunks communicate, on the one hand, by short wide passages, with the 'stigmata,' 'spiracles,' or breathing-pores (*g*), through which the air enters and is discharged; whilst they give-off branches to the different segments, which divide again and again into ramifications of extreme minuteness. They usually communicate also with a pair

FIG. 290

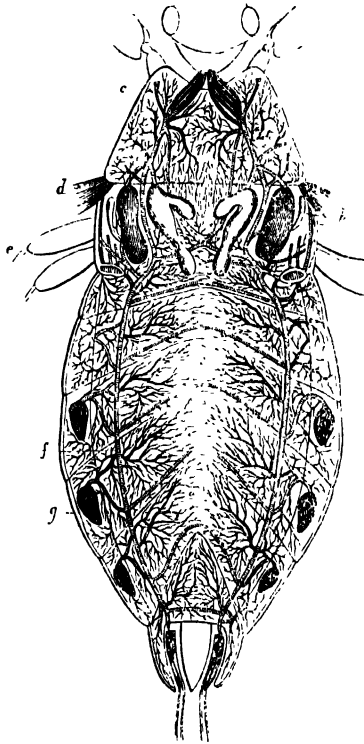

Tracheal system of *Nepa* (Water-scorpion) — *a*, head, *b*, first pair of legs, *c*, first segment of the thorax; *d*, second pair of wings, *e*, second pair of legs; *f*, tracheal trunk, *g*, one of the stigmata, *h*, air-sac

of air-sacs (*h*) which is situated in the thorax; but the size of these (which are only found in the perfect insect, no trace of them existing in the larva) varies greatly in different tribes, being usually greatest in those insects which (like the bee) can sustain the longest and most powerful flight, and least in such as habitually live upon the ground or upon the surface of the water. The structure of the air-tubes reminds us of that of the 'spiral vessels' of Plants, which seem destined (in part at least) to perform a similar office (§ 232); for within the membrane that forms their outer wall, an elastic fibre winds round and round, so as to form a spiral, closely resembling in its position and functions the spiral wire-spring of flexible gas-pipes; within this again, however, there is another membranous wall to the air-tubes, so that the spire winds between their inner and outer coats. The tongue of the Fly presents a curious modification of this structure, the purpose of which is not apparent; for instead of its tracheæ being kept pervious after the usual fashion, by the winding of a continuous spiral fibre through their interior, the fibre is broken into rings, and these rings do not surround the whole tube, but are terminated by a set of

FIG. 291.

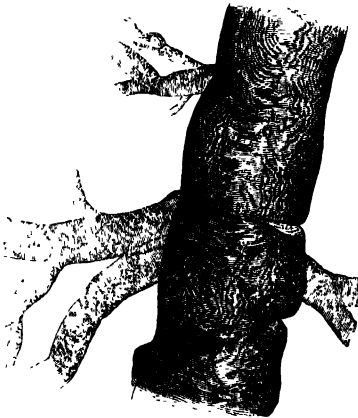

ation of a large Trachea of *Dytiscu*. with
some of its principal branches.

t pass from
one to another (Fig.
287, A).—When a
portion of one of the
great trunks with
some of the principal
branches of the tra-
cheal system has
been dissected-out,
and so pressed in
mounting that the
sides of the tubes
are flattened against
each other (as has
happened in the spe-
cimen represented in
Fig. 291), the spire
forms two layers
which are brought
into close apposition;
and a very beautiful
appearance, resem-

bling that of 'watered silk,' is produced by the crossing of the two sets of fibres, of which one overlies the other. That this appearance, however, is altogether an optical illusion, may be easily demonstrated by carefully following the course of any one of the fibres, which will be found to be perfectly regular.

392. The 'stigmata' or 'spiracles' through which the air enters the tracheal system, are generally visible on the exterior of the body of the Insect (especially on the abdominal segments) as a series of pores along each margin of the under surface. In most larvæ, nearly every segment is provided with a pair; but in the perfect insect, several of them remain closed, especially in the thoracic region, so that their number is often considerably reduced. The structure of the spiracles varies greatly in regard to complexity in different Insects; and even where the general plan is the same, the details of conformation are peculiar, so that perhaps in scarcely any two species are they alike. Generally speaking, they are furnished with some kind of sieve at their entrance, by which particles of dust, soot, &c., which would otherwise enter the air-passages, are filtered-out; and this sieve may be formed by the interlacement of the branches of minute arborescent growths from the borders of the spiracle, as in the common *Fly* (Fig. 292), or in the *Dytiscus*; or it may be a membrane

FIG. 292.

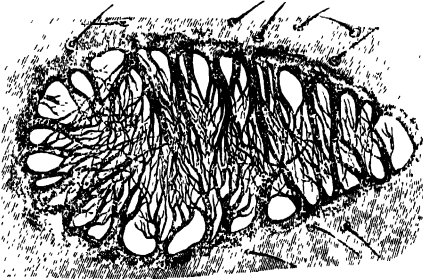
Spiracle of common *Fly*.

perforated with minute holes, and supported upon a framework of bars that is prolonged in like manner from the thickened margin of the aperture (Fig. 293), as in the larva

of the *Melolontha* (cockchafer). Not unfrequently, the centre of the aperture is occupied by an

FIG. 293

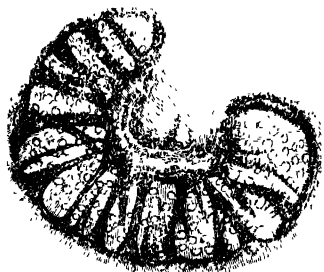
Spiracle of Larva of *Cockchafer*.

impervious disk, from which radii proceed to its margin, as is well seen in the spiracle of *Tipula* (crane-fly).—In those aquatic larvæ which breathe air, we often find one of the spiracles of the last segment of the abdomen prolonged into a tube, the mouth of which remains at the surface, while the body is immersed; the larvæ of the *Gnat* tribe may frequently be observed in this position.

393. There are many aquatic Larvæ, however, which have an entirely-different provision for respiration; being furnished with external leaf-like or brush-like appendages, into which the tracheæ are prolonged, so that, by absorbing air from the water that bathes them, they may convey this into the interior of the body. We cannot have a better example of this, than is afforded by the larva of the common *Ephemera* (day-fly), the body of which is furnished with a set of branchial appendages resembling the 'fin-feet' of Branchiopods (§ 368), whilst the three-pronged tail also is fringed with clusters of delicate hairs which appear to minister to the same function. In the larva of the *Libellula* (dragon-fly), the extension of the surface for aquatic respiration takes-place within the termination of the intestine; the lining membrane of which is folded into an immense number of plats, each containing a minutely-ramified system of tracheæ; the water, slowly drawn-in through the anus for bathing this surface, is ejected with such violence that the body is impelled in the opposite direction; and the air taken-up by its tracheæ is carried, through the system of air-tubes of which they form part, into the remotest organs. This apparatus is a peculiarly interesting object for the Microscope, on account of the extraordinary copiousness of the distribution of the tracheæ in the intestinal folds.

394. The main trunks of the Tracheal system, with their principal ramifications, may generally be got-out with little

difficulty, by laying-open the body of an insect or larva, under water, in a dissecting-trough (§ 104), and removing the whole visceral mass, taking care to leave as many as possible of the branches which will be seen proceeding to this from the two great longitudinal tracheæ, to whose position these branches will serve as a guide. Mr. Quekett recommends the following as the most simple method of obtaining a perfect system of tracheal tubes from a larva:—a small opening having been made in its body, this is to be placed in strong acetic acid, which will soften or decompose all the viscera; and the tracheæ may then be well-washed with the syringe, and removed from the body with the greatest facility, by cutting away the connections of the main tubes with the spiracles by means of fine-pointed scissors. In order to mount them, they should be floated upon the slide, on which they should then be laid-out in the position best adapted for displaying them. If they are to be mounted in Canada balsam, they should be allowed to dry upon the slide, and should then be treated in the usual way; but their natural appearance is best preserved by mounting them in fluid (weak spirit or Goadby's solution), using a shallow cell to prevent pressure. The finer ramifications of the tracheal system may generally be seen particularly well in the membranous wall of the stomach or intestine; and this, having been laid-out and dried upon the glass, may be mounted in balsam so as to keep the tracheæ full of air (whereby they are much better displayed), if care be taken to use balsam that has been previously thickened, to drop this on the object without liquefying it more than is absolutely necessary, and to heat the slide and the cover (the heat may be advantageously applied directly to the cover, after it has been put-on, by turning-over the slide so that its upper face shall look downwards) only to such a degree as to allow the balsam to spread and the cover to be pressed-down.—The spiracles are easily dissected-out by means of a pointed knife or a pair of fine scissors; they should be mounted in fluid, when their texture is soft; and in balsam, when the integument is hard and horny.

395. *Wings*.—These organs are essentially composed of an extension of the external membranous layer of the integument, over a framework formed by prolongations of the inner horny layer; within which prolongations, tracheæ are nearly always to be found, whilst they also contain channels through which blood circulates during the growth of the wing and for a short time after its completion. This is the simple structure

presented to us in the wings of *Neuroptera* (dragon-flies, &c.), *Hymenoptera* (bees and wasps), *Diptera* (two-winged flies), and also of many *Homoptera* (cicadæ and aphides); and the principal interest of these wings as microscopic objects, lies in the distribution of their 'veins' or 'nerves' (for by both names are the ramifications of their skeleton known), and in certain points of accessory structure. The venation of the wings is most beautiful in the smaller *Neuroptera*; since it is the distinguishing feature of this order, that the veins, after subdividing, reunite again, so as to form a close network; whilst in the *Hymenoptera* and *Diptera* such reunions are rare, especially towards the margin of the wings, and the areolæ are much larger. Although the membrane of which these wings are composed, appears perfectly homogeneous when viewed by transmitted light, even with a high magnifying power, yet, when viewed by light reflected obliquely from their surfaces, an appearance of cellular areolation is often discernible; this is well seen in the common *Ily*, in which each of these areolæ has a hair in its centre. In order to make this observation, as well as to bring-out the very beautiful iridescent hues which the wings of many minute insects (as the Aphides) exhibit when thus viewed, it is convenient to hold the wing in the stage-forceps, for the sake of giving it every variety of inclination; and when that position has been found, which best displays its most interesting features, it should be set-up as nearly as possible in the same. For this purpose it should be mounted on an opaque slide; but instead of being laid-down upon its surface, the wing should be raised a little above it, its 'stalk' being held in the proper position by a little cone of soft wax, in the apex of which it may be imbedded. The wings of most *Hymenoptera* are remarkable for the peculiar apparatus by which those of the same side are connected together, so as to constitute in flight but one large wing; this consists of a row of curved hooks on the anterior margin of the posterior wing, which lay hold of the thickened and doubled-down posterior edge of the anterior wing. These hooks are sufficiently apparent in the wings of the common *Bee*, when examined with even a low magnifying power; but they are seen better in the *Wasp*, and better still in the *Hornet*.—The peculiar scaly covering of the wings of the *Lepidoptera* has already been noticed (§ 381); but it may here be added that the entire wings of many of the smaller and commoner insects of this order, such as the *Tineidæ* or 'clothes'-moths,' form very beautiful opaque objects for low

powers; the most beautiful of all being the divided wings of the *Fissipennes* or 'plumed-moths,' especially those of the genus *Pterophorus*.

396. There are many Insects, however, in which the wings are more or less consolidated by the interposition of a layer of horny substance between the two layers of membrane. This plan of structure is most fully carried-out in the Coleoptera (beetles), in which the anterior wings are so much thickened and are so little extended, that they are useless in flight, and serve merely as cases or covers for the posterior, which lie folded-up beneath them when not in use; hence these are distinguished as *elytra*. These clytra, when the insect is at rest, meet along the median line of the back, and cover nearly the whole upper surface of the body; and it is upon them that the brilliant hues, by which the integument of many of these insects is distinguished, are most strikingly displayed. In the anterior wings of the *Forficulidæ* or earwig-tribe (which form the connecting link between this order and the Orthoptera), the cellular structure may often be readily distinguished when they are viewed by transmitted light, especially after having been mounted in Canada balsam. The anterior wings of the Orthoptera (grasshoppers, crickets, &c.) although not by any means so solidified as those of Coleoptera, contain a good deal of horny matter; they are usually rendered sufficiently transparent, however, by Canada balsam, to be viewed with transmitted light; and many of them are so coloured as to be very showy objects (as are also the posterior fan-like wings) for the solar or gas-microscope, although their large size, and the absence of any minute structure, prevent them from affording much interest to the ordinary Microscopist. We must not omit to mention, however, the curious sound-producing apparatus which is possessed by most insects of this order, and especially by the common *House-Cricket*: this consists of the 'tympanum' or drum, which is a space on each of the upper wings, scarcely crossed by veins, but bounded externally by a large dark vein provided with three or four longitudinal ridges, and of the 'file' or 'bow,' which is a transverse horny ridge in front of the tympanum, furnished with numerous teeth; and it is believed that the sound is produced by the rubbing of the two bows across each other, while its intensity is increased by the sounding-board-action of the tympanum. The wings of the *Fulgoridæ* (lantern-flies) have much the same texture with those of the Orthoptera, and possess about the same value as microscopic objects; .

differing considerably from the purely-membranous wings of the Cicadæ and Aphides, which are associated with them in the order Homoptera. In the order Hemiptera, to which belong various kinds of land and water insects that have a suctional mouth resembling that of the common *Bug*, the wings of the anterior pair are usually of parchmenty consistence, though membranous near their tips, and are often so richly coloured as to become very beautiful objects, when mounted in balsam and viewed by transmitted light; this is the case especially with the terrestrial vegetable-feeding kinds, such as the *Pentatoma* and its allies, some of the tropical forms of which rival the most brilliant of the Beetles. The British species are by no means so interesting; and the aquatic kinds, which, next to the bed-bugs, are the most common, always have a dull brown or almost black hue; even among these last, however,—of which the *Notonecta* (water-boatman) and the *Nepa* (water-scorpion) are well-known forms,—the wings are beautifully variegated by differences in the depth of that hue.

397. *Feet*.—Although the feet of Insects are formed pretty much on one general plan, yet that plan is subject to considerable modifications, in accordance with the habits of life of different species. The entire limb usually consists of five divisions, namely, the *coxa* or hip, the *trochanter*, the *femur* or thigh, the *tibia* or shank, and the *tarsus* or foot; and this last portion is made-up of several successive joints. The typical number of these joints seems to be five; but that number is subject to reduction; and the vast order Coleoptera is subdivided into primary groups, according as the tarsus consists of five, four, or three segments. The last joint of the tarsus is usually furnished with a pair of strong hooks or claws (Figs. 294, 295); and these are often serrated (that is, furnished with saw-like teeth), especially near the base. The under surface of the other joints is frequently beset with tufts of hairs, which are arranged in various modes, sometimes forming a complete 'sole;' this is especially the case in the family *Curculionidæ*; so that a pair of the feet of the 'diamond-beetle,' mounted so that one shows the upper surface made resplendent by its jewel-like scales, and the other the hairy cushion beneath, is a very interesting object. In many Insects, especially of the *Fly* kind, the foot is furnished with a pair of membranous expansions, termed *pulvilli* (Fig. 294); and these are beset with numerous hairs, each of which has a minute disk at its extremity. This

structure is evidently connected with the power which these insects possess, of walking over smooth surfaces in opposition to the force of gravity; yet there is still considerable uncertainty as to the precise mode in which it ministers to this faculty. Some believe that the 'pulvilli' act as suckers, the insect being held up by the pressure of the air against their upper surface, when a vacuum is formed beneath; whilst others maintain

FIG. 294.

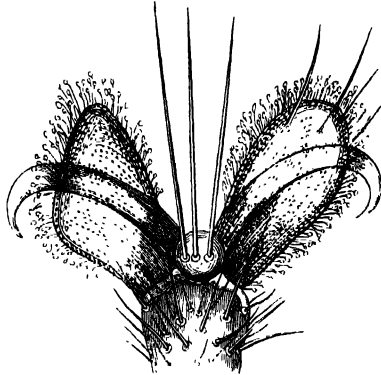
Foot of *Fly*.

that the adhesion is the result of the secretion of a viscid liquid from the under side of the foot. The careful observations of Mr. Hepworth have led him to a conclusion which seems in harmony with all the facts of the case; namely, that the minute disks at the extremity of the individual hairs act as suckers, and that each of them secretes a liquid, which, though not viscid, serves to make its adhesion perfect.* And this view of the case derives confirmation, from the presence of a similar apparatus, on a far larger scale, on the foot of the *Dytiscus* (Fig. 295, A). The first joints of the tarsus of this insect are widely expanded, so as to form a nearly-circular plate; and this is provided with a very remarkable apparatus of suckers, of which one disk (*a*) is extremely large, and is furnished with strong radiating fibres, a second (*b*) is a smaller one formed on the same plan (a third, of the like kind, being often present), whilst the greater number are comparatively-small tubular club-shaped bodies, each having a very delicate membranous sucker at its extremity, as seen on a larger scale at B. These last seem to

* See Mr. Hepworth's communications to the "Quart. Journ. of Microscop. Science," vol. ii., p. 158, and vol. iii., p. 312.

resemble the hairs of the Fly's foot in every particular but dimension; and an intermediate size is presented by the hairs

FIG. 295.

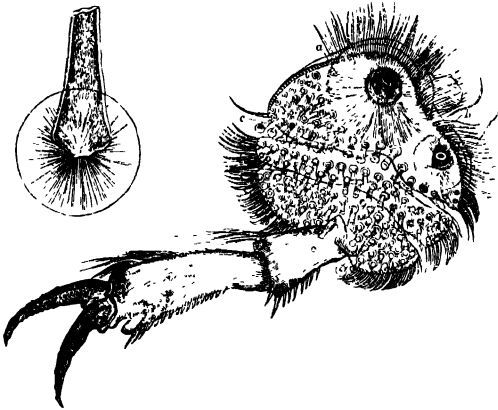

A, Foot of *Dytiscus*, showing its apparatus of suckers; *a*, *b*, large suckers; *c*, ordinary suckers;—*b*, one of the ordinary suckers more highly magnified.

of many beetles, especially Curculionidæ.—The feet of Caterpillars differ considerably from those of perfect Insects. Those of the first three segments, which are afterwards to be replaced by true legs, are furnished with strong horny claws; but each of those of the other segments, which are termed 'pro-legs,' is composed of a circular series of comparatively slender curved hooklets, by which the caterpillar is enabled to cling to the minute roughnesses of the surface of the leaves, &c., on which it feeds. This structure is well seen in the pro-legs of the common Silk-worm.

398. *Stings and Ovipositors*.—The Insects of the order *Hymenoptera* are all distinguished by the prolongation of the last segment of the abdomen into a peculiar organ, which, in one division of the order, is a 'sting,' and in the other is an 'ovipositor,'—an instrument for the deposition of the eggs, which is usually also provided with the means of boring a hole for their reception. The former group consists of the Bees, Wasps, Ants, &c.; the latter of the Saw-flies, Gall-flies,

Ichneumon-flies, &c. These two sets of instruments are not so unlike in structure, as they are in function.—The ‘sting’ is usually formed of a pair of darts, beset with barbed teeth at their points, and furnished at their roots with powerful muscles whereby they can be caused to project from their sheath, which is a horny case formed by the prolongation of the integument of the last segment, slit into two halves, which separate to allow the protrusion of the sting; whilst the peculiar ‘venom’ of the sting is due to the ejection, by the same muscular action, of a poisonous liquid, from a bag situated near the root of the sting, which passes down a canal excavated between the darts, so as to be inserted into the puncture which they make. The stings of the common Bee, Wasp, and Hornet, may all be made to display this structure without much difficulty in the dissection.—The ‘ovipositor’ of such insects as deposit their eggs in holes ready-made, or in soft animal or vegetable substances (as is the case with the *Ichneumonidae*), is simply a long tube, which is enclosed, like the sting, in a cleft sheath. In the Gall-flies (*Cynipidae*), the extremity of the ovipositor has a toothed edge, so as to act as a kind of saw, whereby harder substances may be penetrated; and thus an aperture is made in the leaf, stalk, or bud of the plant or tree infested by the particular species, in which the egg is deposited, together with a drop of fluid that has a peculiarly-irritating effect upon the vegetable tissues, occasioning the production of the ‘galls,’ which are new growths that serve not only to protect the larvæ, but also to afford them nutriment. The Oak is infested by several species of these insects, which deposit their eggs in different parts of its fabric; and some of the small ‘galls’ which are often found upon the surface of oak-leaves, are extremely beautiful objects for the lower powers of the Microscope. It is in the *Tenthredinidae*, or Saw-flies, and in their allies the *Siricidae*, that the ovipositor is furnished with the most powerful apparatus for penetration; and some of these insects can bore by its means into hard timber. Their ‘saws’ are not unlike the ‘stings’ of Bees, &c., but are broader, are toothed for a greater length, and are made to slide along a firm piece that supports each blade, like the ‘back’ of a carpenter’s ‘tenon-saw;’ they are worked alternately (one being protruded while the other is drawn-back) with great rapidity; and when the perforation has been made, the two blades are separated enough to allow the passage of the eggs between them.—Many other Insects, especially of the order

Diptera, have very prolonged ovipositors, by means of which they can insert their eggs into the integuments of animals, or into other situations in which the larvæ will obtain appropriate nutriment; a remarkable example of this is furnished by the Gad-fly (*Tabanus*), whose ovipositor is composed of several joints, capable of being drawn-together or extended like those of a telescope, and is terminated by boring instruments; and the egg being conveyed by its means, not only *into* but *through* the integument of the Ox, so as to be imbedded in the tissue beneath, a peculiar kind of inflammation is set-up there, which (as in the analogous case of the gall-fly) forms a nidus appropriate both to the protection and to the nutrition of the larva. Other Insects which deposit their eggs in the ground, such as the *Locusts*, have their ovipositors so shaped as to answer for digging holes for their reception.—The preparations which serve to display the foregoing parts, are best seen when mounted in balsam; save in the case of the muscels and poison-apparatus of the sting, which are better preserved in weak spirit or Goadby's solution.

399. The sexual organs of Insects furnish numerous objects of extreme interest to the Anatomist and Physiologist; but as an account of them would be unsuitable to the present work, a reference to a copious source of information respecting one of their most curious features, and to a list of the species that afford good illustrations, must here suffice.* The *Eggs* of many Insects are objects of great beauty, on account of the regularity of their form, and the symmetry of the markings on their surface (Fig. 296). The most interesting belong for the most part to the Lepidopterous order; and there are few among these that are not worth examination, some of the commonest (such as those of the Cabbage-butterfly, which are found covering large patches of the leaves of that plant) being as remarkable as any. Those of the puss-moth (*Cerura vinula*), the privet hawk-moth (*Sphinx ligustri*), the small tortoise-shell butterfly (*Vanessa urticae*), the meadow-brown butterfly (*Hipparchia janira*), the brimstone-moth (*Rumia crataegata*), and the silk-worm (*Bombyx mori*), may be particularly specified; and from other orders, those of the cockroach (*Blatta orientalis*), field cricket (*Acheta campestris*), water scorpion (*Nepa ranatra*), bug (*Cimex lectularius*),

* See the Memoirs of M. Lacaze-Duthiers 'Sur l'armure genitale des Insectes,' in "Ann. des Sci. Nat." 3ième Sér., tom. xii., xiv., xvii., xviii., xix.; and M. Ch. Robin's "Mémoire sur les Objets qui peuvent être conservés en Préparations Microscopiques" (Paris, 1856), which is peculiarly full in the enumeration of the objects of interest afforded by the class of Insects.

cow-dung-fly (*Scatophaga stercoraria*), and blow-fly (*Musca vomitoria*). In order to preserve these eggs, they must be mounted in fluid in a cell; since they will otherwise dry-up

FIG. 296.

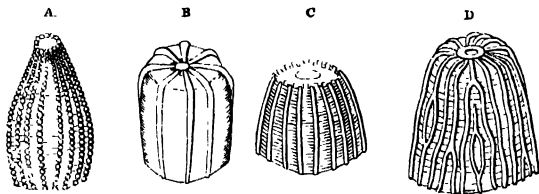

Eggs of Insects, magnified —A, *Pontia napi*; B, *Vanessa urticae*; C, *Hipparchia tithous*; D, *Argynnis Lathonia*.

and become misshapen.—The remarkable mode of reproduction that exists among the *Aphides* must not pass unnoticed here, from its curious connection with the non-sexual reproduction of *Eutomostraca* (§ 369) and *Rotifera* (§ 279), as also of *Hydra* (§ 301) and *Zoophytes* generally, all of which fall specially, most of them exclusively, under the observation of the Microscopist. The wingless *Aphides* which may be seen in the spring and early summer, may be considered as larvæ or pupæ (the earlier states of this insect not being distinguishable from its perfect form, except by their want of wings); and these larvæ, which, though commonly designated as females, are really of no sex, give origin to a brood of similar wingless *Aphides*, which come into the world alive, and which, before long, go through a like process of multiplication. As many as from seven to ten successive broods may thus be produced in the course of a single season; so that from a single *Aphis*, it has been calculated that no fewer than ten thousand million millions may be evolved within that period. In the later part of the year, however, some of these larval *Aphides* attain their full development into winged males and females, by which the true generative process is performed, whose products are eggs, which, when hatched in the succeeding spring, give origin to a new brood of larvæ that repeat the curious life-history of their predecessors.* The

* For a careful examination and philosophical appreciation of the real nature of this process, see Dr. Waldo J. Burnett's Memoir in the "Transactions of the American Academy of Arts and Sciences," 1853.

non-sexual multiplication of the larvæ is obviously a process of *gemmation*, analogous to the multiplication of cells by subdivision; whilst the true Generative process, analogous to the *conjugation* of cells, is only performed when perfect Aphides of distinct sexes have been evolved.

400. *Arachnida*.—The general remarks which have been made in regard to Insects, are equally applicable to this class; which includes, along with the *Spiders* and *Scorpions*, the tribe of *Acarida*, which consists of the *Mites* and *Ticks*. Many of these last are parasitic, and are popularly associated with the wingless parasitic Insects, to which they bear a strong general resemblance, save in having eight legs instead of six. The true 'mites' (*Acarinæ*) generally have the legs adapted for walking, and some of them are of active habits. The common *cheese-mite*, as seen by the naked-eye, is familiar to every one; yet few who have not seen it under a microscope, have any idea of its real conformation and movements; and a cluster of them, cut out of the cheese they infest, and placed under a magnifying power sufficiently low to enable a large number to be seen at once, is one of the most amusing objects that can be shown to the young. There are many other species, which closely resemble the cheese-mite in structure and habits, but which feed upon different substances; and some of these are extremely destructive. To this group belongs a small species, the *Sarcoptes scabiei*, whose presence appears to be the occasion of one of the most disgusting diseases of the skin—the itch,—and which is hence commonly termed the 'itch-insect.' It is not found in the pustule itself, but in a burrow which passes-off from one side of it, and which is marked by a red line on the surface; and if this burrow be carefully examined, the creature will very commonly, but not always, be met-with. It is scarcely visible to the naked eye; but when examined under the microscope, it is found to have an oval body, a mouth of conical form, and eight feet, of which the four anterior are terminated by small suckers, whilst the four posterior end in very prolonged bristles. The male is only about half the size of the female. The *Ricinie* or 'ticks' are usually destitute of eyes, but have the mouth provided with lancets, that enable them to penetrate more readily the skins of animals whose blood they suck. They are usually of a flattened, round, or oval form; but they often acquire a very large size by suction, and become distended like a blown bladder. Different species are parasitic upon different animals; and they bury their suckers (which are often furnished with

minute recurved hooks) so firmly in the skins of these, that they can hardly be detached without pulling-away the skin with them. It is probably the young of a species of this group, which is commonly known as the 'harvest-bug,' and which is usually designated as the *Acarus autumnalis*; this is very common in the autumn upon grass or other herbage, and insinuates itself into the skin at the roots of the hair, producing a painful irritation; like other Acarida, for some time after their emersion from the egg, it possesses only six legs (the other pair being only acquired after the first moult), so that its resemblance to parasitic insects becomes still stronger.—It is probable that to this group also belongs the *Demodex folliculorum*, a creature which is very commonly found parasitic in the sebaceous follicles of the human skin, especially in those of the nose. In order to obtain it, pressure should be made upon any one of these that appears enlarged and whitish, with a terminal black spot; the matter forced-out will consist principally of the accumulated sebaceous secretion, having the parasites with their eggs and young mingled with it. These are to be separated by the addition of oil, which will probably soften the sebaceous matter sufficiently to set-free the animals, which may be then removed with a pointed brush; but if this mode should not be effectual, the fatty matter may be dissolved-away by digestion in a mixture of alcohol and ether. The pustules in the skin of a dog affected with the 'mange' have been found by Mr. Topping to contain a *Demodex*, which seems only to differ from that of the human sebaceous follicles in its somewhat smaller size; and M. Gruby is said to have given to a dog a disease resembling the mange, if not identical with it, by inoculating it with the human parasite.—The *Acarida* are best preserved as microscopic objects, by mounting in glycerine.

401. The number of objects of general interest, furnished to the Microscopist by the *Spider* tribe, is by no means considerable. Their eyes exhibit a condition intermediate between that of Insects and Crustaceans, and that of Vertebrata; for they are single like the 'stemmata' of the former, usually number from six to eight, are sometimes clustered-together in one mass, but are sometimes disposed separately, while they present a decided approach in internal structure to the type characteristic of the visual organs of the latter.—The structure of the Mouth is always mandibulate, and is less complicated than that of the mandibulate insects.—The Respiratory apparatus, which, where developed at all among the

Acarida, is tracheary like that of Insects, is here constructed upon a very different plan; for the 'stigmata,' which are usually four in number on each side, open into a like number of respiratory sacculi, each of which contains a series of leaf-like folds of its lining membrane, upon which the blood is distributed so as to afford a large surface to the air. In the structure of the limbs, the principal point worthy of notice is the peculiar appendage with which they usually terminate; for the strong claws, with a pair of which the last joint of the foot is furnished, have their edges cut into comb-like teeth (Fig. 297), which seem to be used by the animal as cleansing-instruments.—One of the most curious parts of the organization of the

FIG. 297.



Foot, with comb-like claws of the common *Spider* (*Epeira*).

of the Spiders, is the 'spinning-apparatus' by means of which they fabricate their elaborately-constructed webs. This consists of the 'spinnerets', and of the glandular organs in which the fluid that hardens into the thread is elaborated. The usual number of the spinnerets,

which are situated at the posterior extremity of the body, is six; they are little teat-like prominences, beset with hairy appendages; and it is through a certain set of these appendages, which are tubular and terminate in fine-drawn points, that the glutinous secretion is forced-out in a multitude of streams of extreme minuteness. These streams harden into fibrils, immediately on coming into contact with the air; and the fibrils proceeding from all the apertures of each spinneret, coalesce into a single thread. It is doubtful, however, whether all the spinnerets are in action at once, or whether those of different pairs may not have dissimilar functions; for whilst the radiating threads of a spider's web are simple (Fig. 298, A), those which lie across these, forming its concentric circles or rather polygons, are studded at intervals

with viscid globules (B), which appear to give to these threads their peculiarly adhesive character; and it does not seem by any means unlikely, that each kind of thread should be produced by its own pair of spinnerets. The total number of spinning-tubes varies greatly, according to the species of the spider, and the sex and age of the individual; being more than 1000 in some cases, and less than 100 in others. The size and complexity of the secreting glandulæ vary in like manner: thus in the Spiders which are most remarkable for the large dimensions and regular construction of their webs, they occupy a large portion of the abdominal cavity, and are composed of slender branching tubes, whose length is increased by numerous convolutions; whilst in those which have only occasional use for their threads, the secreting organs are either short and simple follicles, or are undivided tubes of moderate length.

FIG. 298.

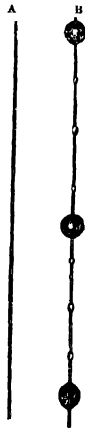

Ordinary thread (A), and glutinous thread (B), of the common Spider.

CHAPTER XVIII.

VERTEBRATED ANIMALS.

402. WE are now arrived at that highest division of the Animal Kingdom, in which the bodily fabric attains its greatest development, not only as to completeness, but also as to size; and it is in most striking contrast with the class we have been last considering. — Since not only the entire bodies of Vertebrated animals, but, generally speaking, the smallest of their integral parts, are far too large to be viewed as Microscopic objects, we can study their structure only by a separate examination of their component elements; and it seems, therefore, to be a most appropriate course, to give, under this head, a sketch of the microscopic characters of those *primary tissues*, of which their fabric is made-up, and which, although they may be traced with more or less distinctness in the lower tribes of Animals, attain their most complete development in this group.—Since the time when Schwann first made public the remarkable results of his researches (p. 28), it has been very generally believed that all the Animal tissues are formed, like those of Plants, by a metamorphosis of *Cells*; an exception being taken, however, by some Physiologists, in regard to the simple Fibrous tissues (§ 417). The tendency of many recent investigations, however, has been to throw further doubt on the generality of this doctrine; since they appear to indicate that many other tissues than the fibrous may be formed (like these) by the consolidation of the *plasma* or formative fluid, without passing through the intermediate condition of cells. Hence no attempt will here be made to do more than describe the most important of those distinctive characters, which the principal tissues present, when subjected to microscopic examination; and as it is of no essential consequence what order is adopted, we may conveniently begin with the structure of the *skeleton*,* which gives support and protection to the softer parts of the fabric.

* This term is used in its most general sense, as including not only the proper *vertebral* or internal skeleton, but also the hard parts protecting the exterior of the body, which form the *dermal* skeleton.

403. *Bone*.—The Microscopic characters of osseous tissue may sometimes be seen in very thin natural plates of bone, such as in that forming the scapula (shoulder-blade) of a Mouse; but they are displayed more perfectly by artificial sections, the details of the arrangement being dependent upon the nature of the specimen selected, and the direction in which the section is made. Thus when the shaft of a 'long' bone of a Bird or Mammal is cut-across in the middle of its length, we find it to consist of a hollow cylinder of dense bone, surrounding a cavity which is occupied by an oily marrow; but if the section be made nearer its extremity, we find the outside wall gradually becoming thinner, whilst the interior, instead of forming one large cavity, is divided into a vast number of small chambers or *cancelli*, which communicate with each other and with the cavity of the shaft, and are filled, like it, with marrow. In the bones of Reptiles and Fishes, on the other hand, this 'cancellated' structure usually extends throughout the shaft, which is not so completely differentiated into solid bone and medullary cavity, as it is in the higher Vertebrata. In the most-developed kinds of 'flat' bones, again, such as those of the head, we find the two surfaces to be composed of dense plates of bone, with a 'cancellated' structure between them; whilst in the less perfect type presented to us in the lower Vertebrata, the whole thickness is usually more or less 'cancellated,' that is, burrowed-out by medullary cavities. When we examine, under a low magnifying power, a longitudinal section of a 'long' bone, or a section of a 'flat' bone parallel to its surface, we find it traversed by numerous canals, termed *Haversian* after their discoverer Havers, which are in connection with the central cavity, and are filled, like it, with marrow: in the shafts of long bones, these canals usually run in the direction of their length, but are connected here and there by cross branches; whilst in the flat bones, they form an irregular network.—On applying a higher magnifying power to a thin transverse section of a long bone, we observe that each of the canals whose orifices present themselves in the field of view (Fig. 299), is the centre of a rod of bony tissue (1), usually more or less circular in its form, which is arranged around it in concentric rings, resembling those of an Exogenous Stem. These rings are marked-out and divided by circles of little dark spots; which, when closely examined (2), are seen to be minute flattened cavities excavated in the solid substance of the bone, from the two flattened sides of which pass-forth a

number of extremely minute tubules, one set extending inwards, or in the direction of the centre of the system of

FIG. 299.

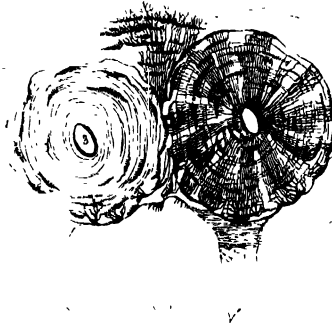

Minute structure of *Bone*, as seen in transverse section. - 1, an ossicle surrounding an Haversian canal, 3, showing the concentric arrangement of the lamellæ, 2, the same, with the lacunæ and canaliculi, 4, portions of the lamellæ parallel with the external surface.

rings, and the other outwards, or in the direction of its circumference; and by the inosculation of the tubules (which are termed *canaliculi*) of the different rings with each other, a continuous communication is established between the central Haversian canal and the outermost part of the bony rod that surrounds it, which doubtless ministers to the nutrition of the texture. Bloodvessels are traceable into the Haversian canals; but the 'canaliculi,' being far too minute to carry blood-corpuscles, can only convey a nutrient fluid

that is separated from the blood for the special service of the bone.

404. The minute cavities, or *lacunæ* (sometimes, but erroneously termed 'bone-corpuscles,' as if they were solid bodies), from which the canaliculi proceed,

FIG. 300.



Lacunæ of Osseous substance:—*a*, central cavity
b, its ramifications.

are highly characteristic of the true osseous structure; being never deficient in the minutest parts of the bones of the higher Vertebrata, although those of Fishes are occasionally destitute of them. The dark appearance which they present is not due to opacity, but is simply an optical effect, dependent (like the blackness of air-bubbles in liquids) upon the dispersion of the rays by the highly-refracting substance that surrounds them (§ 98). The size and form of the lacunæ differ considerably in the several Classes of Vertebrata, and even in some instances in the Orders; so as to allow of the determination of the tribe to which a bone belonged, by the microscopic examination of even a minute fragment of it (§ 453). The following are the average dimensions of the lacunæ, in characteristic examples drawn from the four principal classes, expressed in fractions of an inch:—

	<i>Long Diameter.</i>	<i>Short Diameter.</i>
Man	1-1410 to 1-2100	1-4000 to 1-8000
Ostrich	1-1333 to 1-2250	1-5125 to 1-9650
Turtle	1-375 to 1-1150	1-4500 to 1-5810
Conger-eel	1-550 to 1-1135	1-4500 to 1-8000

The lacunæ of *Birds* are thus distinguished from those of *Mammals* by their somewhat greater length and smaller breadth; but they differ still more in the remarkable tor-

FIG. 301.

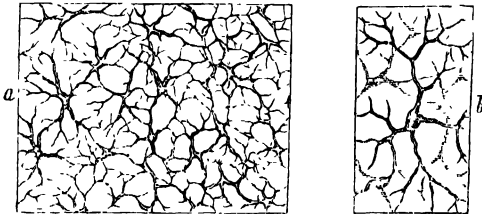

Section of the bony scale of *Lepidosteus*:—*a*, showing the regular distribution of the lacunæ and of the connecting canaliculi; *b*, small portion more highly magnified.

tuosity of the canaliculi, which wind backwards and forwards in a very irregular manner. There is an extraordinary increase in length in the lacunæ of *Reptiles*, without a corresponding increase in breadth; and this is also seen in some *Fishes*, though in general the lacunæ of the latter are remarkable for their angularity of form, and the fewness of their radiations,

—as shown in Fig. 301, which represents the lacunæ and canaliculi in the bony scale of the *Lepidosteus* ('bony pike' of the North American lakes and rivers), with which the bones of its internal skeleton perfectly agree in structure. The dimensions of the lacunæ in any bone do not bear any relation to the size of the animal to which it belonged; thus there is little or no perceptible difference between their size in the enormous extinct *Iguanodon*, and in the smallest *Lizard* now inhabiting the earth. But they bear a close relation to the size of the blood-corpuscles in the several classes; and this relation is particularly obvious in the 'perennibranchiate' *Batrachia*, the extraordinary size of whose blood-corpuscles will be presently noticed (§ 414):—

	<i>Long Diameter.</i>	<i>Short Diameter.</i>
<i>Proteus</i> . . .	1-570 to 1-980	1-885 to 1-1200
<i>Siren</i> . . .	1-290 to 1-480	1-540 to 1-975
<i>Menopoma</i> . . .	1-450 to 1-700	1-1300 to 1-2100
<i>Lepidosiren</i> . . .	1-375 to 1-494	1-980 to 1-2200
<i>Pterodactyle</i> . . .	1-145 to 1-1185	1-4000 to 1-5225*

405. In preparing sections of bone, it is important to avoid the penetration of the Canada balsam into the interior of the lacunæ and canaliculi; since, when these are filled by it, they become almost invisible. Hence it is preferable not to employ this cement at all, except, it may be, in the first instance; but to rub-down the section beneath the finger, guarding its surface with a slice of cork or a slip of gutta-percha (§ 111); and to give it such a polish, that it may be seen to advantage even when mounted dry. As the polishing, however, occupies much time, the benefit which is derived from covering the surfaces of the specimen with Canada balsam may be obtained, without the injury resulting from the penetration of the balsam into its interior, by adopting the following method. A quantity of balsam proportioned to the size of the specimen is to be spread upon a glass slip, and to be rendered stiffer by boiling, until it becomes nearly solid when cold; the same is to be done to the thin-glass-cover; next, the specimen being placed on the balsamed surface of the slide, and being overlaid by the balsamed cover, such a degree of warmth is to be applied, as will suffice to liquefy the balsam, without causing it to flow freely; and the glass cover is then to be

* See Prof. J. Quekett's Memoir on this subject, in the "Transact. of the Microsc. Soc." Ser. 1, vol. ii.; and his more ample illustration of it in the "Illustrated Catalogue of the Histological Collection in the Museum of the Roy. Coll. of Surgeons," vol. ii.

quickly pressed-down, and the slide to be rapidly cooled, so as to give as little time as possible for the penetration of the liquefied balsam into the lacunar system.—The same method may be employed in making sections of Teeth.

406. *Teeth*.—The intimate structure of the Teeth in the several classes and orders of Vertebrata presents differences which are no less remarkable than those of their external form, arrangement and succession. It will obviously be impossible here to do more than sketch some of the most important of these varieties.—The principal part of the substance of all teeth is made-up of a solid tissue that has been appropriately termed *Dentine*. In the Shark tribe, as in many other Fishes, the general structure of this 'dentine' is extremely analogous to that of bone; the tooth being traversed by numerous canals, which are continuous with the haversian canals of the subjacent bone, and receive blood-vessels from them (Fig. 302); and each of these canals being

FIG. 302.

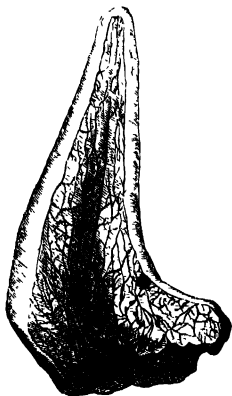

FIG. 303.

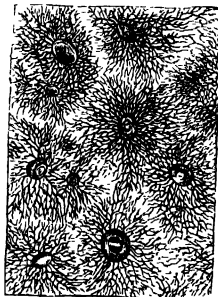

FIG. 302. Perpendicular section of tooth of *Lamna*, moderately enlarged, showing network of medullary canals.

FIG. 303. Transverse section of portion of tooth of *Pristis*, more highly magnified, showing orifices of medullary canals, with systems of radiating and inosculating tubuli.

surrounded by a system of tubuli (Fig. 303), which radiate into the surrounding solid substance. These tubuli, however,

do not enter lacunæ, nor is there any concentric annular arrangement around the medullary canals; but each system of tubuli is continued onwards through its own division of the tooth, the individual tubes sometimes

FIG. 304

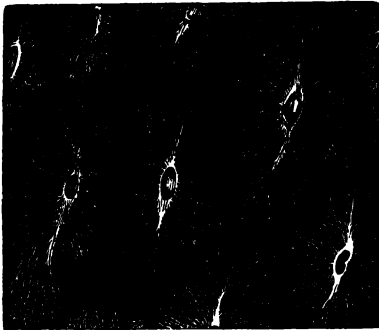

Transverse Section of Tooth of *Myliobates* (Eagle Ray) viewed as an opaque object.

giving-off lateral branches, whilst in other instances their trunks bifurcate. This arrangement is peculiarly well displayed, when sections of teeth constructed upon this type are viewed as opaque objects (Fig. 304). —In the teeth of the higher Vertebrata, however, we usually find the centre excavated into a single cavity (Fig. 305), and the remainder

destitute of vascular canals; but there are intermediate cases (as in the teeth of the great fossil Sloths) in which the inner portion of the dentine is traversed by prolongations of this cavity, conveying blood-vessels, which do not pass into the exterior layers. The tubuli of the 'non-vascular' dentine, which exists by itself in the teeth of nearly all Mammalia, and which in the Elephant is known as 'ivory,' all radiate from the central cavity, and pass towards the surface of the tooth in a nearly-parallel course. Their diameter at their largest part averages 1-10,000th of an inch; their smallest branches are immeasurably fine. It is impossible that even the largest of them can receive blood, as their diameter is far less than that of the blood-discs; but it is probable that, like the canaliculi of bone, they may absorb nutrient matter from the vascular surface upon which their inner extremities open. The tubuli in their course present greater and lesser undulations; the former are few in number; but the latter are numerous, and as they occur at the same part of the course of several contiguous tubes, they give rise to the appearance of lines concentric with

the centre of radiation. These secondary curvatures probably indicate, in dentine, as in the crab's shell (§ 374), successive stages of calcification.

407. In the teeth of Man and most other Mammals, and in those of many Reptiles and some Fishes, we find two other substances, one of them harder, and the other softer, than dentine; the former is termed *Enamel*; and the latter *Cementum* or *Crusta Petrosa*.—The *Enamel* is composed of long prismatic cells, closely resembling those of the prismatic shell-substance formerly described (§ 336), but on a far more minute scale; the diameter of the cells not being more, in Man, than 1-5600th of an inch. The length of the prisms corresponds with the thickness of the layer of enamel; and the two surfaces of this layer present the ends of the prisms, the form of which usually approaches the hexagonal. The course of the enamel-prismus is more or less wavy; and they are marked by numerous transverse striae, resembling those of the prismatic shell-substance, and probably originating in the same cause,—the coalescence of a series of shorter cells, to form the lengthened prism. In Man, and in Carnivorous animals, the enamel covers the crown of the tooth only, with a simple cap or superficial layer of tolerably uniform thickness (Fig. 305, *a*), which follows the surface of the dentine in all its inequalities; and its component prisms are directed at right angles to that surface, their inner extremities resting in slight but regular depressions on the exterior of the dentine. In the teeth of many of the Herbivorous animals, however, the Enamel forms (with the Cementum) a series of vertical plates, which dip down into the substance of the dentine, and present their edges alternately with it, at the grinding surface of the tooth; and there is in such teeth no continuous layer of

FIG. 305.

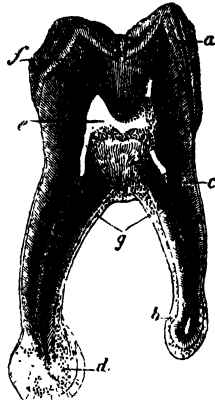

Vertical section of *Huma* Molar Tooth:—*a*, enamel; *b*, cementum or crusta petrosa; *c*, dentine or ivory; *d*, osseous excrescence, arising from hypertrophy of cementum; *e*, pulp-cavity; *f*, osseous lacunæ at outer part of dentine.

enamel over the crown. The purpose of this arrangement is evidently to provide, by the unequal wear of these three substances,—of which the enamel is the hardest, and the cementum the softest,—for the constant maintenance of a rough surface, adapted to triturate the tough vegetable substances on which these animals feed. The enamel is the least constant of the dental tissues. It is more frequently absent than present in the teeth of the class of Fishes; it is wanting in the entire order of Ophidia (serpents) among existing Reptiles; and it forms no part of the teeth of the Edentata (sloths, &c.) and Cetacea (whales) amongst Mammals.—The *Cementum*, or *Crusta Petrosa*, has the characters of true bone; possessing its distinctive stellate lacunæ and radiating canaliculi. Where it exists in small amount, we do not find it traversed by medullary canals; but, like dentine, it is occasionally furnished with them, and thus resembles bone in every particular. These medullary canals enter its substance from the exterior of the tooth, and consequently pass towards those which radiate from the central cavity in the direction of the surface of the dentine, where this possesses a similar vascularity,—as was remarkably the case in the teeth of the extinct *Megatherium*. In the Human tooth, however, the cementum has no such vascularity; but forms a thin layer, which envelops the root of the tooth, commencing near the termination of the capping of enamel (Fig. 305, *b*). In the teeth of many Herbivorous Mammals, it dips-down with the enamel to form the vertical plates of the interior of the tooth; and in the teeth of the Edentata, as well as of many Reptiles and Fishes, it forms a thick continuous envelope over the whole surface, until worn-away at the crown.

408. *Dermal Skeleton*.—The skin of Fishes, of most Reptiles, and of a few Mammals, is strengthened by plates of a horny, cartilaginous, bony, or even enamel-like texture, which are sometimes fitted-together at their edges, so as to form a continuous box-like envelope, whilst more commonly they are so arranged as partially to overlie one another, like the tiles on a roof; and it is in this latter case that they are usually known as *scales*. Although we are accustomed to associate in our minds the ‘scales’ of Fishes with those of Reptiles, yet they are essentially-different structures; the former being developed in the substance of the true skin, with a layer of which, in addition to the epidermis, they are always covered; and bearing a resemblance to cartilage and bone in their texture and composition; whilst the latter are formed upon the surface of the true skin, and are to be considered as analo-

gous to nails, hoofs, &c., and other 'epidermic appendages.' In nearly all the existing Fishes, the scales are flexible, being but little consolidated by calcareous deposit; and in some species they are so thin and transparent, that, as they do not project obliquely from the surface of the skin, they can only be detected by raising the superficial layer of the skin, and searching beneath it, or by tearing-off the entire thickness of the skin, and looking for them near its under surface. This is the case, for example, with the common *Eel*, and with the *Viviparous Blenny*; of either of which fish, the skin is a very interesting object when dried and mounted in Canada balsam, the scales being seen imbedded in its substance, whilst its outer surface is studded with pigment-cells. Generally speaking, however, the posterior extremity of each scale projects obliquely from the general surface, carrying before it the thin membrane that encloses it, which is studded with pigment-cells; and a portion of the skin of almost any Fish, but especially of such as have scales of the *ctenoid* kind (that is, furnished at their posterior extremities with comb-like teeth Fig. 307), when dried with its scales *in situ*, is a very beautiful opaque object for the low-powers of the Microscope (Fig. 306). Care must be taken, however, that the light is

made to glance upon it in the most advantageous manner; since the brilliancy with which it is reflected from the comb-like projections, entirely depends upon the angle at which it falls upon them. The only appearance of structure ex-

FIG. 306

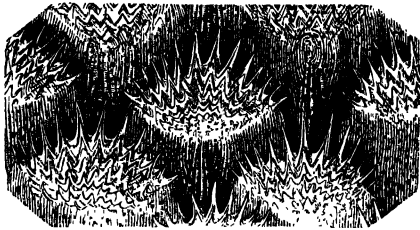
Portion of Skin of *Sole*, viewed as an opaque object.

hibited by the thin flat scale of the *Eel*, when examined microscopically, is the presence of a layer of isolated spheroidal transparent bodies, imbedded in a plate of like transparency; these, from the researches of Prof. Williamson upon other scales, appear not to be cells (as they might readily be supposed to be), but to be concretions of carbonate of lime. When the scale of the *Eel* is examined by polarized light, its surface exhibits a beautiful St. Andrew's cross; and if a plate

of selenite be placed behind it, and the analysing prism be made to revolve, a remarkable play of colours is presented.

409. In studying the structure of the more highly-developed scales, we may take as an illustration that of the *Carp*; in which two very distinct layers can be made-out by a vertical section, with a third but incomplete layer interposed between them. The outer layer is composed of several concentric laminae of a structureless transparent substance, like that of cartilage; the outermost of these laminae is the smallest, and the size of the plates increases progressively from without inwards, so that their margins appear on the surface as a series of concentric lines; and their surfaces are thrown into ridges and furrows, which commonly have a radiating direction. The inner layer is composed of numerous laminae of a fibrous structure, the fibres of each lamina being inclined at various angles to those of the lamina above and below it. Between these two layers is interposed a stratum of calcareous

FIG. 307.

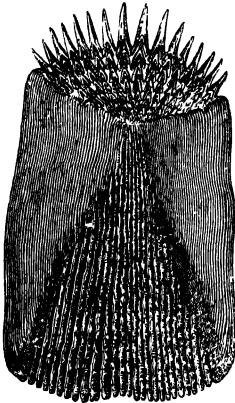

Scale of *Sole*, viewed as a transparent object.

concretions, resembling those of the scale of the *Eel*; these are sometimes globular or spheroidal, but more commonly 'lenticular,' that is, having the form of a double-convex lens. The scales which resemble those of the *Carp* in having a form more or less circular, and in being destitute of comb-like prolongations, are called *cycloid*; and such are the characters of those of the salmon, herring, roach, &c. The structure of the 'ctenoid' scales (Fig. 307), which we find in the sole, perch, pike, &c., does not differ essentially from that of the 'cycloid,' save as to the projection of the comb-like teeth from the posterior margin; and it does not appear that the strongly-marked division which Prof. Agassiz has attempted to establish between the 'cycloid' and the 'ctenoid'

orders of fishes, on the basis of this difference, is in harmony with their general organization. Scales of either kind may become consolidated to a considerable extent, by the calcification

of their soft substance; but still they never present any approach to the true bony structure, such as is shown in the two orders to be next adverted-to.—In the *ganoid* scales, on the other hand, the whole substance of the scale is composed of a substance which is essentially bony in its nature; its intimate structure being almost always comparable to that of one or other of the varieties which present themselves in the bones of the Vertebrate skeleton; and being very frequently identical with that of the bones of the same fish, as is the case with the *Lepidosteus* (Fig. 301), one of the few existing representatives of this order, which, in former ages of the Earth's history, comprehended a large number of important families. Their name (from *γάνος* splendour) is bestowed on account of the smoothness, hardness, and high polish of the outer surface of the scales; which is due to the presence of a peculiar layer that has been likened (though erroneously) to the enamel of teeth, and is now distinguished as *ganoin*. The scales of this order are for the most part angular in their form; and are arranged in regular rows, the posterior edges of each slightly overlapping the anterior ones of the next, so as to form a very complete defensive armour to the body.—The scales of the *placoid* type, which characterizes the existing Sharks and Rays, with their fossil analogues, are irregular in their shape, and very commonly do not come into mutual contact; but are separately imbedded in the skin, projecting from its surface under various forms. In the Rays, each scale usually consists of a flattened plate of a rounded shape, with a hard spine projecting from its centre; in the Sharks (to which tribe belongs the 'dog-fish' of our own coast) the scales have more of the shape of teeth. This resemblance is not confined to external form; for their intimate structure strongly resembles that of dentine, their dense substance being traversed by tubuli, which extend from their centre to their circumference in minute ramifications, without any trace of osseous lacunæ. These tooth-like scales are often so small, as to be invisible to the naked eye; but they are well seen by drying a piece of the skin to which they are attached, and mounting it in Canada balsam; and they are most brilliantly shown by the assistance of polarized light.—A like structure is found to exist in the spiny-rays of the dorsal fin, which, also, are parts of the dermal skeleton; and these rays usually have a central cavity filled with medulla, from which the tubuli radiate towards the circumference. This structure is very well seen in thin sections of the fossil spiny-rays, which, with the teeth and scales, are often the sole

relics of the vast multitudes of Sharks that must have swarmed in the ancient seas, their cartilaginous internal skeletons having entirely decayed-away.—In making sections of bony scales, spiny rays, &c., the method must be followed which has been already detailed under the head of bone (§ 405).

410. The *scales* of Reptiles, the *feathers* of Birds, and the *hairs, hoofs, nails, claws, and horns* (when not bony) of Mammals, are all *Epidermic* appendages; that is, they are produced upon the surface, not within the substance, of the true skin, and are allied in structure to the Epidermis (§ 419); being essentially composed of aggregations of cells, filled with horny matter; and frequently much altered in form. This structure may generally be made-out in horns, nails, &c., with little difficulty, by treating thin sections of them with a dilute solution of soda; which after a short time causes the cells that had been flattened into scales, to resume their globular form. The most interesting modifications of this structure are presented to us in Hairs and in Feathers; which forms of clothing are very similar to each other in their essential structure, and are developed in the same manner,—namely, by an increased production of epidermic cells at the bottom of a flask-shaped follicle, which is formed in the substance of the true skin, and which is supplied with abundance of blood by a special distribution of vessels to its walls. When a hair is pulled-out ‘by its root,’ its base exhibits a bulbous enlargement, of which the exterior is tolerably firm, whilst its interior is occupied by a softer substance, which is known as the ‘pulp;’ and it is to the continual augmentation of this pulp in the deeper part of the follicle, and to its conversion into the peculiar substance of the hair when it has been pushed-upwards to its narrow neck, that the growth of the hair is due. The same is true of feathers, the stems of which are but hairs on a larger scale; for the ‘quill’ is the part contained within the follicle, answering to the ‘bulb’ of the hair; and whilst the outer part of this is converted into the peculiarly-solid horny substance forming the ‘barrel’ of the quill, its interior is occupied, during the whole period of the growth of the feather, with the soft pulp, only the shrivelled remains of which, however, are found within it after the quill has ceased to grow.

411. Although the *Hairs* of different Mammals differ greatly in the appearances they present, we may generally distinguish in them two elementary parts; namely, a *cortical* or investing substance, of a dense horny texture, and a

medullary or pith-like substance, usually of a much softer texture, occupying the interior. The former can sometimes be distinctly made-out to consist of flattened scales arranged in an imbricated manner, as in some of the hairs of the *Sable* (Fig. 308); whilst, in the same hairs, the medullary substance is

FIG. 308.

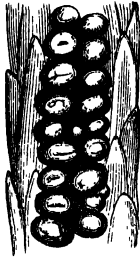

FIG. 309.

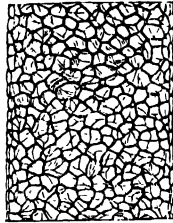
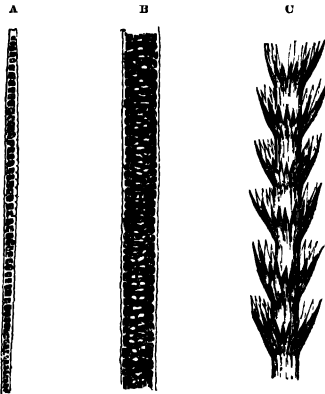

FIG. 308. Hair of *Sable*, showing large rounded cells in its interior, covered by imbricated scales or flattened cells.

FIG. 309. Hair of *Musk-deer*, consisting almost entirely of polygonal cells.

composed of large spheroidal cells. In the *Musk-deer*, on the other hand, the cortical substance is nearly undistinguishable; and almost the entire hair seems made up of thin-walled polygonal cells (Fig 309). The hair of the *Reindeer*, though much larger, has a very similar structure; and its cells, except near the root, are occupied with air alone, so as to seem black by transmitted light, except when penetrated by the fluid in which

FIG. 310.



A, Small Hair of *Squirrel*:—B, Large Hair of *Squirrel*:—C, Hair of *Indian But.*

they are mounted. In the hair of the *Mouse*, *Squirrel*, and other small Rodents (Fig. 310, A, B), the cortical substance forms a tube, which we see crossed at intervals by partitions that are sometimes complete, sometimes only partial; these are the walls of the single or double line of cells, of which the medullary substance is made-up. The hairs of the *Bat* tribe are commonly distinguished by the projections on their surface, which are formed by extensions of the component scales of the cortical substance; these are particularly well seen in the hairs of one of the Indian species, which has a set of whorls of long narrow leaflets (so to speak) arranged at regular intervals on its stem (c). In the hair of the *Pecari* (Fig. 311), the cortical envelope sends

FIG. 311.

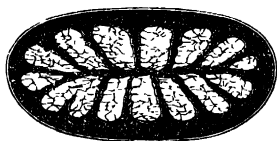

Transverse Section of Hair of
Pecari.

inwards a set of radial prolongations, the interspaces of which are occupied by the polygonal cells of the medullary substance; and this, on a larger scale, is the structure of the 'quills' of the *Porcupine*; the radiating partitions of which, when seen through the more transparent parts of the cortical sheath, give to the surface of the latter a fluted appearance. The hair of the *Ornithorhynchus* is a very curious object; for whilst the lower part of it resembles the fine hair of the mouse or squirrel, this thins-away and then dilates again into a very thick fibre, having a central portion composed of polygonal cells, enclosed in a flattened sheath of a brown fibrous substance.—The structure of the *Human* hair is in certain respects peculiar. When its outer surface is examined, it is seen to be traversed by irregular lines (Fig. 312, A), which are most strongly marked in fetal hairs; and these are the indications of the imbricated arrangement of the flattened cells or scales which form the cortical layer. This layer, as is shown by transverse sections (C, D), is a very thin and transparent cylinder; and it incloses the peculiar fibrous substance, that constitutes the principal part of the shaft of the hair. The constituent fibres of this substance, which are marked-out by the delicate striæ that may be traced in longitudinal sections of the hair (B), may be separated from each other by crushing the hair, especially after it has been macerated for some time in sulphuric acid; and each of them, when completely sepa-

rated from its fellows, is found to be a long spindle-shaped cell. In the axis of this fibrous cylinder, there is very commonly a

FIG. 312.

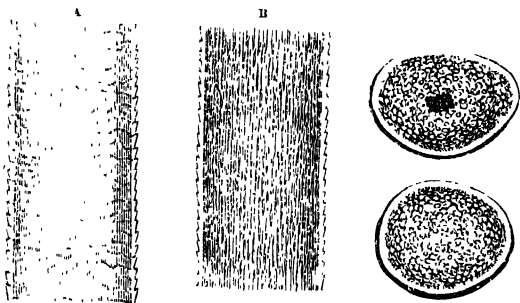

Structure of *Human Hair*:—A, external surface of the shaft, showing the transverse striae and jagged boundary caused by the imbrications of the cortical substance, B, longitudinal section of the shaft, showing the fibrous character of the medullary substance, and the arrangement of the pigmentary matter; C, transverse section, showing the distinction between the transparent envelope, the cylinder of medullary substance, and the cellular centre; D, another transverse section showing deficiency of central cellular substance.

band which is formed of spheroidal cells; but this is usually deficient in the fine hairs scattered over the general surface of the body, and is not always present in those of the head.* The hue of the hair is due, partly to the presence of pigmentary granules, either collected into patches, or diffused through its substance; but partly also to the existence of a multitude of minute air-spaces, which cause it to appear as dark by transmitted and white by reflected light. The cells of the axis-band, in particular, are very commonly found to contain air, giving it the black appearance shown at C. The difference between the blackness of pigment and that of air-spaces, may be readily determined by attending to the characters of the latter as already laid-down (§§ 98, 99); and by

* Several writers regard this band of polygonal cells as the 'medullary' substance, and the fibrous structure which forms the principal body of the hair, as the 'cortical' substance; the transparent sheath receiving some separate designation. To the Author, however, it appears perfectly clear that the transparent horny sheath, with its lines of imbrication, is the representative of the cortical substance of other hairs; and that its entire contents, whether polygonal cells or cells elongated into fusiform fibres, must be considered as equivalent to their medullary substance.

watching the effects of the penetration of oil of turpentine or other liquids, which do not alter the appearance of pigment spots, but obliterate all the markings produced by air-spaces, these returning again as the hair dries.—In mounting hairs as microscopic preparations, they should in the first instance be cleansed of all their fatty matter by maceration in ether; and they may then be put-up, either in weak spirit or in Canada balsam, as may be thought preferable, the former menstruum being well adapted to display the characters of the finer and more transparent hairs, while the latter allows the light to penetrate more readily through the coarser and more opaque. Transverse sections of hairs are best made by gluing or gumming several together, and then putting them into the section-instrument; those of human hair may be easily obtained, however, by shaving a second time, very closely, a part of the surface over which the razor has already passed more lightly, and by picking-out from the lather, and carefully washing, the sections thus taken-off.

412. The stems of *Feathers* exhibit the same kind of structure as hairs; their cortical portion being the horny sheath that envelopes the shaft, and their medullary portion being the pith-like substance which that sheath includes. In small feathers, this may usually be made very plain by mounting them in Canada balsam; in large feathers, however, the texture is sometimes so altered by the drying-up of the pith (the cells of which are always found to be occupied by air alone), that the cellular structure cannot be demonstrated, save by boiling thin slices in a dilute solution of potass, and not always even then. In small feathers, especially such as have a downy character, the cellular structure is very distinctly seen in the *laminae* or 'barbs,' which are sometimes found to be composed of single files of pear-shaped cells, laid end-to-end; but in larger feathers, it is usually necessary to increase the transparency of the barbs, especially when these are thick and but little pervious to light, either by soaking them in turpentine, mounting them in Canada balsam, or boiling them in a weak solution of potass. In the feathers which are destined to strike the air with great force in the act of flight, we find the barbs fringed on each side with hair-like filaments or *pinnae*; on one side of each barb these filaments are toothed on one edge, whilst on the other side they are furnished with curved hooks; and as the two sets of *pinnae* which spring from two adjacent barbs, cross one another at an angle, and each hooked *pinna* on one locks into

the teeth of several of the toothed *Pinnæ* arising from the other, the barbs are connected together very firmly by this apparatus of 'hooks and eyes,' which reminds us of that already mentioned as to be observed on the wings of Hymenopterous Insects (§ 395).—Feathers or portions of feathers of birds distinguished by the splendour of their plumage, are very good objects for low magnifying powers, when illuminated on an opaque ground; but care must be taken that the light falls upon them at the angle necessary to produce their most brilliant reflection into the axis of the microscope; since feathers which exhibit the most brilliant metallic lustre to an observer at one point, may seem very dull to the eye of another in a different position. The small feathers of Humming birds, portions of the feathers of the Peacock, and others of a like kind, are well worthy of examination; and the scientific Microscopist who is but little attracted by mere gorgeousness, may well apply himself to the discovery of the peculiar structure, which imparts to these objects their most remarkable character.

413. Sections of *Horns, Hoofs, Claws*, and other like modifications of Epidermic structure,—which may be made by the Section-instrument (§ 107), the substance to be cut having been softened, if necessary, by soaking in warm-water,—do not in general afford any very interesting features, when viewed in the ordinary mode; but there are no objects on which Polarized light produces more remarkable effects, or which display a more beautiful variety of colours, when a plate of selenite is placed behind them, and the analysing prism is made to rotate. A curious modification of the ordinary structure of horn, is presented in the appendage borne by the *Rhinoceros* upon its snout, which in many points resembles a bundle of hairs, its substance being arranged in minute cylinders around a number of separate centres, which have probably been formed by independent papillæ (Fig. 313). When transverse sections of these cylinders are viewed by polarized light, each of them is seen to be marked by a cross, somewhat resembling that of starch-grains; and the lights and shadows of this cross are replaced by contrasted colours, when the selenite-plate is interposed. The substance commonly but erroneously termed *Whalebone*, which is formed from the surface of the membrane that lines the mouth of the whale, and has no relation to its true bony skeleton, is almost identical in structure with *Rhinoceros-horn*, and is similarly affected by polarized light. The central portion of each of its

component fibres, like the medullary substance of hairs, contains cells that have been so little altered as to be easily

FIG. 313



Transverse Section of Horn of *Rhinoceros*, viewed by Polarized Light.

recognized; and the outer or cortical portion also may be shown to have a like structure, by macerating it in a solution of potass, and then in water. — Sections of any of the horny tissues are best mounted in Canada balsam.

414. *Blood.* —

Carrying our Microscopic survey, now, to the elementary parts of which those softer tissues are made up, that are subservient to th

active life of the body, rather than to its merely-mechanical requirements, we shall in the first place notice the isolated floating cells contained in the Blood, and known as the 'blood-corpuscles.' These are of two kinds; the 'red,' and the 'white' or 'colourless.' The former present, in every instance, the form of a flattened disk, which is circular in Man and in most Mammalia (Fig. 315), but which is oval in Birds, Reptiles (Fig. 311), and Fishes, and in a few Mammals (all belonging to the *Camel* tribe); in the one form as in the other, this disk is a flattened cell, whose walls are pellucid and colourless, but whose contents are coloured. They may be caused to swell-up and burst, however, by the imbibition of water; and the perfect transparency and the homogeneous character of their walls then become evident. The 'red corpuscles' in the blood of Oviparous Vertebrata are distinguished by the presence of a distinct central spot or *nucleus*, which appears to be composed of an aggregation of minute granules; this is most distinctly brought into view by treating the blood-discs with acetic acid, which renders the remaining portion extremely transpa-

rent, while it increases the opacity of the nucleus (Fig. 314, *d*). It is remarkable, however, that the 'red corpuscles' of the blood of Mammals should possess no obvious nucleus; the dark spot which is seen in their centre (Fig. 315, *b*), being merely an effect of refraction, consequent upon the double-concave form of the disk.

When the corpuscles are treated with water, so that their form becomes first flat, and then double-convex, the dark spot disappears; whilst, on the other hand, it is made more evident when the concavity is increased by the partial emptying of the cell, which may be accomplished by treating the blood-

corpuscles with fluids of greater density than their own contents. The size of the 'red corpuscles' is not altogether uniform in the same blood; thus it varies in that of Man, from about the 1-4000th to the 1-2800th of an inch. But we generally find that there is an average size, which is pretty constantly maintained among the different individuals of the same species; that of Man may be stated at about 1-3200th of an inch. The following Table* exhibits the average dimensions of some of the most interesting examples of the Red blood-

* These measurements are chiefly selected from those given by Mr. Gulliver in his edition of Hewson's Works, p. 236, *et seq.*

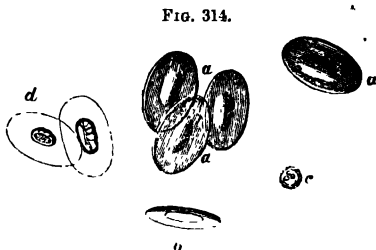

Red Corpuscles of *Frog's* Blood:—*a, a*, their flattened face, *b*, particle turned nearly edgewise; *c*, colourless corpuscle; *d*, red corpuscles altered by dilute acetic acid.

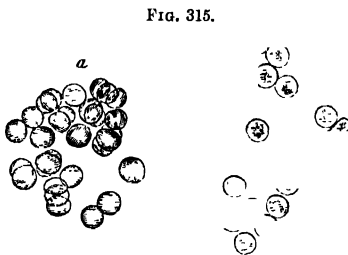

Red Corpuscles of *Human* Blood; represented at *a*, as they are seen when rather within the focus of the microscope, and at *b*, as they appear when precisely in the focus.

corpuscles, in the four classes of Vertebrated Animals, expressed in fractions of an inch. Where two measurements are given, they are the long and the short diameters of the same corpuscle.

MAMMALS.

Man	1-3200	Camel	1-3254, 1-5921
Dog	1-3542	Llama	1-3361, 1-6294
Whale	1-3099	Java Musk-Deer	1-12325
Elephant	1-2745	Caucasian Goat	1-7045
Mouse	1-3814	Two-toed Sloth	1-2865

BIRDS.

Golden Eagle	1-1812, 1-3832	Ostrich	1-1649, 1-3000
Owl	1-1830, 1-3400	Cassowary	1-1455, 1-2800
Crow	1-1961, 1-4000	Heron	1-1913, 1-3491
Blue-Tit	1-2313, 1-4128	Fowl	1-2102, 1-3466
Parrot	1-1898, 1-4000	Gull	1-2097, 1-4000

REPTILES.

Turtle	1-1231, 1-1882	Frog	1-1108, 1-1821
Crocodile	1-1231, 1-2286	Water-Newt	1-814, 1-1246
Green Lizard	1-1555, 1-2743	Siren	1-420, 1-760
Slow-worm	1-1178, 1-2666	Proteus	1-337
Viper	1-1274, 1-1800	Lepidosiren	1-570, 1-941

FISHES.

Perch	1-2099, 1-2824	Pike	1-2000, 1-3555
Carp	1-2142, 1-3429	Eel	1-1745, 1-2842
Gold-Fish	1-1777, 1-2824	Gymnotus	1-1745, 1-2599

Thus it appears that the *smallest* red corpuscles known are those of the *Musk-Deer*; whilst the *largest* are those of that curious group of Batrachian (frog-like) Reptiles which retain their gills through the whole of life; and the oval blood-disks of the *Proteus*, being above 36 times as long as those of the Musk-deer, and probably at least 20 times as broad, would cover no fewer than 720 of them.

415. The 'colourless' corpuscles are more readily distinguished in the blood of Reptiles, than in that of Man; being, in the former case, of much smaller size, as well as having a circular outline (Fig. 314, *c*); whilst in the latter, their size and contour are nearly the same, so that, as the red corpuscles themselves, when seen in a single layer, have but a very pale hue, the deficiency of colour does not sensibly mark their difference of nature. It is remarkable that, notwithstanding the great variations in the sizes of the red corpuscles in different species of Vertebrated animals, the size of the 'colourless' is extremely constant throughout, their diameter being seldom much greater or less than 1-3000th of an inch in the warm-blooded classes, and 1-2500th in Reptiles. Their ordinary form is globular; but their aspect is subject to consider-

able variations, which seem to depend in great part upon their phase of development. Thus in their early state, in which they seem to be identical with the corpuscles found floating in *Chyle* and *Lymph*, the cell-wall can scarcely be distinguished from the large nuclear mass which it incloses; by treating the cell with water or acetic acid, however, the membrane is distended, and the nucleus very commonly breaks-up into fragments in its interior. This last appearance seems natural to the corpuscle in a more advanced condition; and the isolated particles are often to be seen executing an active molecular movement within the cell, which continues when they are discharged by the bursting of the cell, consequent upon the addition of a solution of potass. These corpuscles are occasionally seen to exhibit very curious changes of form, which remind us of those of the *Amoeba* (§ 261); a protrusion taking-place from some portion of the cell-wall, the form of which seems quite indeterminate; and this being soon succeeded by another, from some different part of the cell, the first being either drawn-in again, or remaining as it was. These changes have been observed, not only in the 'colourless corpuscles' of the blood of various Vertebrated animals, but also in the corpuscles floating in the circulating fluid of the higher Invertebrata, such as the Crab, which resemble the 'colourless' corpuscles of Vertebrated blood rather than its 'red' corpuscles,—these last, in fact, being altogether peculiar to the circulating fluid of Vertebrated animals.

416. In examining the Blood microscopically, it is, of course, of importance to obtain as thin a stratum of it as possible, so that the corpuscles may not overlies one another. This is best accomplished by selecting a piece of thin glass of perfect flatness, and then, having received a small drop of blood upon a glass slide, to lay the thin glass, not upon this, but with its edge just touching the edge of the drop; for the blood will then be drawn-in by capillary attraction, so as to spread in a uniformly-thin layer between the two glasses. The inexperienced observer will be surprised at the very pale hue which the red corpuscles exhibit beneath the microscope, when seen in a single stratum; but this surprise need no longer be felt, when it is borne in mind that the thickness of the film of colouring fluid which they contain, is probably not more than 1-20,000th of an inch; and if a drop of ink, or of almost any coloured liquid, however dark, be pressed-out between two glasses into an equally thin film, its hue will be lightened in the same degree. The red hue of the corpuscles,

however, becomes obvious enough, when two or more layers of them are seen-through at once. The 'colourless corpuscles' in Human blood are usually not more than 1:350 of the 'red,' so that no more than one or two are likely to be in the field at once; and these may generally be recognized most readily, by their standing-apart from the rest; for whilst the 'red' corpuscles have a tendency to adhere to each other by their discoidal surfaces, the 'colourless' show no such disposition. Thin films of blood may be preserved in the liquid state, with little change, by applying gold-size or asphalté round the edge of the thin-glass cover before evaporation has had time to take place; but it is in some respects preferable to dilute the liquid with a small quantity of Goadby's solution, its strength being so adjusted as not to produce any endosmotic change of form in the corpuscles. But it is far simpler to allow such films to dry, without any cover, and then merely to cover them for protection; and in this condition the general characters of the corpuscles can be very well made-out, notwithstanding that they have in some degree shrivelled by the desiccation they have undergone. And this method is particularly serviceable, as affording a fair means of comparison, when the assistance of the Microscopist is sought in determining, for Medico-legal purposes, the source of suspicious blood-stains; the average dimensions of the dried blood-corpuscles of the several domestic animals, being sufficiently different from each other and from those of Man, to allow the nature of any specimen to be pronounced-upon with a high degree of probability.

417. *Simple Fibrous Tissues*.—A large proportion of every animal fabric is made-up of *simple fibres*, whose function is to hold other parts together, or to serve as cords for the communication of movement. A very beautiful example of a fibrous tissue of this kind, is furnished by the membrane of the common Fowl's egg, which (as may be seen by examining an egg whose shell remains soft for want of consolidation by calcareous particles), consists of two principal layers, one serving as the basis of the shell itself, and the other forming that lining to it, which is known as the *membrana putaminis*. The latter may be separated, by careful tearing with needles and forceps, after prolonged maceration in water, into several matted lamellæ resembling that represented in Fig. 316; and similar lamellæ may be readily obtained from the shell itself, by dissolving-away its lime by dilute acid. The simply-fibrous structures of the body generally, however, belong to one of

two very definite kinds of tissue; the 'white' and the 'yellow,' whose appearance, composition, and properties are very different.—The *white* fibrous tissue, though sometimes apparently composed of distinct fibres, more commonly presents the aspect of bands, usually of a flattened form, and attaining the breadth of 1-500th of an inch, which are marked by numerous longitudinal streaks, but can seldom be torn-up into minute fibres of determinate size. The fibres and bands are occasionally somewhat wavy in their direction; and they have a peculiar tendency to fall into undulations, when it is attempted to tear them apart from each other (Fig. 317). This tissue is easily distinguished from the other, by the effect of acetic acid, which swells it up and renders it transparent, at the same time bringing into view certain oval nuclear corpuscles. It is perfectly inelastic; and we find it in such parts as tendons, ordinary ligaments, fibrous capsules, &c., whose function it is to resist tension without yielding to it.—The *yellow* fibrous tissue exists in the form of long, single, elastic, branching filaments, with a dark decided border; which are disposed to curl when not put on the stretch (Fig. 318). They are for the most part between 1-5000th and 1-10,000th of an inch in diameter; but they are often met-with both larger and smaller. They frequently anastomose, so as to form a network. This tissue does not undergo any change, when treated with acetic acid. It exists alone (that is,

FIG. 316.

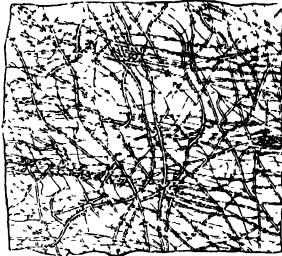

Fibrous membrane from Egg-shell.

FIG. 317.



White Fibrous Tissue, from Ligament.

without any mixture of the white) in parts which require a peculiar elasticity, such as the middle coat of the Arteries,

FIG. 318.



Yellow Fibrous Tissue from Ligamentum Nuchæ
of Calf.

the Vocal Cords, the 'ligamentum nuchæ' of Quadrupeds, the elastic ligament which holds together the valves of a Bivalve shell, and that by which the claws of the Feline tribe are retracted when not in use; and it enters largely into the composition of *Areolar* tissue.

This consists of

a network of minute fibres and bands, which are interwoven in every direction, so as to leave innumerable *areolæ* or little spaces, which communicate freely with one another. Of these fibres, some are of the yellow or elastic kind; but the majority are composed of the white fibrous tissue; and, as in that form of elementary structure, they frequently present the form of broad flattened bands, or membranous shreds, in which no distinct fibrous arrangement is visible. The proportion of the two forms varies, according to the amount of elasticity, or of simple resisting power, which the endowments of the part may require. We find this tissue in a very large proportion of the bodies of higher Animals; thus it binds-together the ultimate fibres of the muscles and nerves into minute fasciculi, unites these fasciculi into larger ones, these again into still larger ones which are obvious to the eye, and these into the entire muscle; whilst it also forms the membranous divisions between distinct muscles. In like manner it unites the elements of nerves, glands, &c., binds-together the fat-cells into minute masses, these into larger ones, and so on; and in this way it penetrates and forms part of all the softer organs of the body.—For the display of the characters of these tissues, small and thin shreds may be cut with the curved scissors from any part that affords them; and these must be torn-asunder with needles under the simple microscope, until

the fibres are separated to a degree sufficient to enable them to be examined to advantage under a higher magnifying power.

418. *Skin, Mucous and Serous Membranes.*—The Skin which forms the external envelope of the body, is divisible into two principal layers; the ‘true skin,’ which usually makes-up by far the larger part of its thickness, and the ‘cuticle,’ ‘scarf-skin,’ or Epidermis, which covers it. At the mouth, nostrils, and the other orifices of the open cavities and canals of the body, the skin passes into the membrane that lines these, which is distinguished as the Mucous membrane, from the peculiar glairy secretion of mucus by which its surface is protected. But the great closed cavities of the body, which surround the heart, lungs, intestines, &c., are lined by membranes of a different kind; which, as they secrete only a thin serous fluid from their surfaces, are known as Serous membranes. Both Mucous and Serous membranes consist, like the skin, of a proper membranous basis, and of a thin cuticular layer, which, as it differs in many points from the epidermis, is distinguished as the Epithelium (§ 421).—The substance of the ‘true skin’ and of the ‘mucous’ and ‘serous’ membranes, is principally composed of the fibrous tissues last described; but the skin and the mucous membranes are very copiously supplied with blood-vessels and with glandulæ of various kinds; and in the skin we also find abundance of nerves and lymphatic vessels, as well as, in some parts, of hair-follicles. The distribution of the vessels in the skin and mucous membranes, which is one of the most interesting features in their structure, and which will come under our notice hereafter (Figs. 328, 329), is intimately connected with their several functions. In serous membranes, on the other hand, the supply of blood-vessels is more scanty, their function being simply protective.

419. *Epidermic and Epithelial Cell-layers.*—The Epidermis or ‘cuticle’ covers the exterior surfaces of the body, as a thin semi-transparent pellicle, which is shown by microscopic examination to consist of a series of layers of cells, which are continually wearing-off at the external surface, and are being renewed at the surface of the true skin; so that the newest and deepest layers gradually become the oldest and most superficial, and are at last thrown-off by slow desquamation. In their progress from the internal to the external surface of the Epidermis, the cells undergo a series of well-marked changes. When we examine the innermost layer, we find it soft and

granular; consisting of *nuclei*, in various stages of development into cells, held-together by a tenacious semi-fluid substance. This was formerly considered as a distinct tissue, and was supposed to be the peculiar seat of the colour of the skin; it received the designation of *rete mucosum*. Passing outwards, we find the cells more completely formed; at first nearly spherical in shape, but becoming polygonal where they are flattened one against another. As we proceed further towards the surface, we perceive that the cells are gradually more and more flattened, until they become mere horny scales, their cavity being obliterated; their origin is indicated, however, by the nucleus in the centre of each. This change in form is accompanied by a change in the chemical composition of the tissue, which seems to be due to the metamorphosis of the contents of the cells, into a horny substance identical with that of which hair, horn, nails, hoofs, &c., are composed.—Mingled with the epidermic cells, we find others which secrete colouring matter instead of horn; these are termed 'pigment-cells.' The most remarkable development of 'pigment-cells' in the higher animals, is on the inner surface of the Choroid coat of the eye, where they have a very regular arrangement, and form several layers, known as the *Pigmentum nigrum*. When examined separately, these cells are found to have a polygonal form (Fig. 319, *a*), and to have a distinct

FIG 319.



Cells from *Pigmentum Nigrum*:—*a*, pigmentary granules concealing the nucleus; *b*, the nucleus distinct.

The black colour is given by the accumulation, within the cell, of a number of flat rounded or oval granules, of extreme minuteness, which exhibit an active movement when set free from the cell, and even whilst enclosed within it. The pigment-cells are not always, however, of this simply-rounded or polygonal form; they sometimes present remarkable stellate prolongations, under which form they are well seen in the skin of the Frog (Fig. 327, *c, c*). The gradual formation of these prolongations may be traced in the pigment-cells of the Tadpole (Fig. 320). Similar varieties of form are to be met-with in the pigmentary cells of Fishes

and small Crustacea, which also present a great variety of hues ; and these seem to have the power of likening their colour to that of the bottom over which the animal may live, so as to serve for its concealment.

420. The structure of the Epidermis may be examined in a variety of ways. If it be removed by maceration from the true skin, the cellular nature of its under-surface is at once recognized, when it is subjected to a magnifying power of 200 or 300 diameters, by light

transmitted through it, with this surface uppermost ; and if the epidermis be that of a negro or any other dark-skinned race, the pigment-cells will be very distinctly seen. This under-surface of the epidermis is not flat, but is excavated into pits and channels for the reception of the papillary elevations of the true-skin ; an arrangement which is shown on a large scale in the thick cuticular covering of the Dog's foot, the subjacent papillæ being large enough to be distinctly seen (when injected) with the naked eye. The cellular nature of the newly-forming layers is best seen, by examining a little of the soft film that is found upon the surface of the true skin, after the more consistent layers of the cuticle have been raised by a blister. The alteration which the cells of the external layers have undergone,

tends to obscure their character ; but if any fragment of epidermis be macerated for a little time in a weak solution of soda or potass, its dry scales become softened, and are filled-out by imbibition into rounded or polygonal cells. The same mode of treatment enables us to make-out the cellular structure in warts and corns, which are epidermic growths from the surface of papillæ enlarged by hypertrophy.

421. The Epithelium may be designated as a delicate cuticle, covering all the free *internal* surfaces of the body, and

FIG. 320.



Pigment-cells from tail of Tadpole.—*a, a*, simple forms of recent origin ; *b, b*, more complex forms subsequently assumed.

thus lining all its cavities, canals, &c. Save in the mouth and other parts in which it approximates to the ordinary cuticle both in locality and in nature, its cells usually form but a single layer; and are so deficient in tenacity of mutual adhesion, that they cannot be detached in the form of a continuous membrane. Their shape varies greatly; for sometimes they are broad, flat, and scale-like, and their edges approximate closely to each other, so as to form what is termed a 'pavement' or 'tessellated'-epithelium; such cells are observable on the web of a frog's foot, or on the tail of the tadpole; for, though covering an external surface, the soft moist cuticle of these parts has all the characters of an epithelium. In other cases, the cells have more of the form of cylinders, standing erect side-by-side, one extremity of each cylinder forming part of the free surface, whilst the other rests upon the membrane to which it serves as a covering. If the cylinders be closely pressed-together, their form is changed into prisms; and such epithelium is often known as 'prismatic.' On the other hand, if the surface on which it rests be convex, the bases or lower ends of the cylinders become smaller than their free extremities; and thus each has the form of a truncated cone rather than of a cylinder, and such epithelium (of which that covering the *villi* of the intestine, Fig. 328, is a peculiarly-good example) is termed 'conical.' But between these primary forms of epithelial cells, there are several intermediate gradations; and one often passes almost insensibly into the other.—Any of these forms of Epithelium may be furnished with *cilia*; but these appendages are more commonly found attached to the elongated, than to the flattened forms of epithelium-cells (Fig. 321). 'Ciliated epithelium'

FIG. 321.



Ciliated Epithelium; *a*, nucleated cells, resting on their smaller extremities; *b*, cilia.

is found upon the lining membrane of the air-passages in all air-breathing Vertebrata; and it also presents itself in many other situations, in which a propulsive power is needed to prevent an accumulation of mucous or other secretions. Owing to the very slight attachment that usually exists

between the epithelium and the membranous surface whereon it lies, there is usually no difficulty whatever in examining it;

nothing more being necessary than to ^{scrape} the surface of the membrane with a knife, and to add a little water to what has been thus removed. The ciliary action will generally be found to persist for some hours or even days after death, if the animal has been previously in full vigour;* and the cells that bear the cilia, when detached from each other, will swim freely about in water. If the thin fluid that is copiously discharged from the nose in the first stage of an ordinary 'cold in the head,' be subjected to microscopic examination, it will commonly be found to contain a great number of ciliated epithelium-cells that have been thrown-off from the lining membrane of the nasal passages.

422. *Fat*.—One of the best examples which the bodies of higher animals afford, of a tissue composed of an aggregation of cells, is presented by the Adipose tissue; the cells of which are distinguished by their power of drawing into themselves oleaginous matter from the blood. Fat-cells are sometimes dispersed in the interspaces of Areolar tissue; whilst in other cases they are aggregated in distinct masses,—constituting the proper Adipose tissue. The individual fat-cells always present a nearly spherical or spheroidal form; sometimes, however, when they are closely pressed-together, they become somewhat polyhedral, from the flattening of their walls against each other (Fig. 322). Their intervals are traversed by a minute network of blood-vessels, from which they derive their secretion; and it is probably by the constant moistening of their walls with a *watery* fluid, that their contents are retained without the least transudation, although these are quite fluid at the temperature of the living body. Fat-cells, when filled with their characteristic contents, have the peculiar appearance which has been already described as

FIG. 322

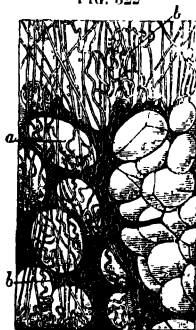

Areolar and Adipose tissue;
a, a, fat-cells; b, b, fibres of
areolar tissue.

* Thus it has been observed in the lining of the windpipe of a decapitated criminal, as much as seven days after death; and in that of the river-tortoise, it has been seen fifteen days after death, even though putrefaction had already far advanced

appertaining to oil-globules (§ 99), being very bright in their centre, and very dark towards their margin, in consequence of their high refractive power; but if, as often happens in preparations that have been long mounted, the oily contents should have escaped, they then look like any other cells of the same form. Although the fatty matter which fills these cells (consisting of a mixture of stearine or of margarine with oleine) is liquid at the ordinary temperature of the body of a warm-blooded animal, yet its harder portion sometimes crystallizes on cooling; the crystals shooting from a centre, so as to form a star-shaped cluster.—In examining the structure of Adipose tissue, it is desirable, where practicable, to have recourse to some specimen in which the fat-cells lie in single layers, and in which they can be observed without disturbing or laying them open; such a condition is found, for example, in the mesentery of the mouse, and it is also occasionally met with in the fat-deposits which present themselves at intervals in the connective tissues of the muscles, joints, &c. Small collections of fat-cells are found in the deeper layers of the true skin, and may be brought into view by vertical sections of it. And the structure of large masses of fat may be examined by thin sections, these being placed under water in thin cells, so as to take-off the pressure of the thin glass from their surface, which would cause the escape of the oil-particles. No method of mounting (so far as the Author is aware) is successful in causing these cells permanently to retain their contents.

423. *Cartilage*.—In the ordinary forms of Cartilage, also, we have an example of a tissue essentially composed of cells;

FIG. 323.

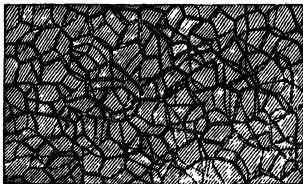

Cellular Cartilage of Mouse's-ear.

but these are commonly separated from each other by an intercellular substance, the thickness of which differs greatly in different kinds of cartilage, and even in different stages of the growth of any one. Thus in the cartilage of the external ear of a *Bat* or *Mouse* (Fig. 323), the cells are packed as closely to-

gether, as are those of an ordinary vegetable parenchyma (Fig. 150, A); and this seems to be the early condition

of most cartilages that are afterwards to present a different aspect. In the ordinary cartilages, however, that cover the extremities of the bones, so as to form smooth surfaces for the working of the joints, the amount of intercellular substance is usually considerable; and the cartilage-cells are commonly found imbedded in this, in clusters of two, three, or four (Fig. 324), which are evidently formed by

a process of 'duplicative subdivision' analogous to that by which the multiplication of cells takes place in the Vegetable Kingdom (Fig. 67). The substance of these *cellular* Cartilages is entirely destitute of blood-vessels; being nourished solely by imbibition from the blood brought to

the membrane covering their surface. Hence they may be compared, in regard to their grade of organization, with the larger Algae; which consist, like them, of aggregations of cells held-together by intercellular substance, without vessels of any kind, and are nourished by imbibition through their whole surface.—There are many cases, however, in which the structureless intercellular substance is replaced by bundles of fibres, sometimes elastic, but more commonly non-elastic; such combinations, which are termed *fibro-cartilages*, are interposed in certain joints, wherein tension as well as pressure has to be resisted, as, for example, between the vertebrae of the spinal column, and the bones of the pelvis.—In examining the structure of Cartilage, nothing more is necessary than to make very thin sections with a sharp razor or scalpel, or with a Valentin's knife (§ 106), or, if the specimen be large and dense (as the cartilage of the ribs), with the section-instrument (§ 107). These sections may be mounted in weak spirit, in Goadby's solution, or in

FIG. 324.

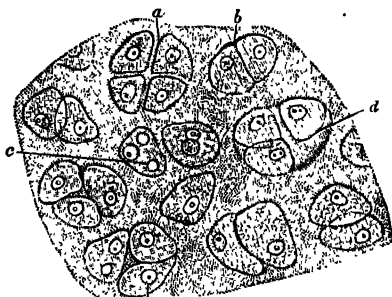

Section of the branchial *Cartilage* of Tadpole; —*a*, group of four cells, separating from each other; *b*, pair of cells in apposition, *c, c*, nuclei of cartilage-cells; *d*, cavity containing three cells.

glycerine; but in whatever way they are mounted, they undergo a gradual change by the lapse of time, which renders them less fit to display the characteristic features of their structure.

424. *Structure of Glands.*—The various secretions of the body (as the saliva, bile, urine, &c.) are formed by the instrumentality of organs termed Glands; which are, for the most part, formed on one fundamental type, whatever be the nature of their product. The simplest idea of a gland is that which we gain from an examination of the ‘follicles’ or little bags imbedded in the wall of the stomach; some of which secrete mucus for the protection of its surface, and others gastric juice. These little bags are filled with cells of a spheroidal form, which may be considered as constituting their epithelial lining; these cells, in the progress of their development, draw into themselves from the blood the constituents of the particular product they are to secrete; and they then seem to deliver it up, either by the bursting or by the melting-away of their walls, so that this product may be poured-forth from the mouth of the bag, into the cavity in which it is wanted. The liver itself, in the lowest animals wherein it is found, presents this condition. Some of the cells that form the lining of the stomach in the Hydra and Actinia, seem to be distinguished from the rest by their power of secreting bile, which gives them a brownish-yellow tinge; in many Polyzoa, Compound Tunicata, and Annelida, these biliary cells can be seen to occupy follicles in the walls of the stomach; in Insects, these follicles are few in number, but are immensely elongated so as to form biliary tubes, which lie loosely within the abdominal cavity, frequently making many convolutions within it, and discharge their contents into the commencement of the intestinal canal; whilst in the higher Mollusca, and in Crustacea, the follicles are vastly multiplied in number, and are connected with the ramifications of gland-ducts, like grapes upon the stalks of their bunch, so as to form a distinct mass, which now becomes known as the liver. The examination of the biliary tubes of the Insect, or of the biliary follicles of the Crab, which may be accomplished with the utmost facility, is well adapted to give an idea of the essential nature of glandular structure. Among Vertebrated animals, the salivary glands, the pancreas (sweetbread), and the mammary glands, are well adapted to display the follicular structure; nothing more being necessary than to make sections of these organs, thin enough to be viewed as transparent objects. The liver

of Vertebrata, however, presents certain peculiarities of structure, which are not yet fully understood; for although it is essentially composed, like other glands, of secreting cells, yet it has not yet been determined beyond doubt, whether these cells are contained within any kind of membranous investment. The kidneys of Vertebrated animals are made-up of elongated tubes, which are straight, and lined with a pavement-epithelium, in the inner or 'medullary' portion of the kidney, whilst they are convoluted, and filled with a spheroidal epithelium, in the outer or 'cortical.' Certain flask-shaped dilatations of these tubes include curious little knots of blood-vessels, which are known as the 'Malpighian bodies' of the kidney; these are well displayed in injected preparations. For such a full and complete investigation of the structure of these organs as the Anatomist and Physiologist require, various methods must be put in practice, which this is not the place to detail. It is perfectly easy to demonstrate the cellular nature of the substance of the liver, by simply scraping a portion of its cut surface; since a number of its cells will be then detached. The general arrangement of the cells in the lobules, may be shown by means of sections thin enough to be transparent; whilst the arrangement of the blood-vessels can only be shown by means of injections (§ 433). Fragments of the tubules of the kidney, sometimes having the Malpighian capsules in connection with them, may also be detached by scraping its cut surface; but the true relations of these parts can only be shown by thin transparent sections, and by injections of the blood-vessels and tubuli. The simple follicles contained in the walls of the stomach are brought into view by vertical sections; but they may be still better examined by leaving small portions of the lining membrane for a few days in dilute nitric acid (one part to four of water), whereby the fibrous tissue will be so softened, that the clusters of glandular epithelium lining the cells (which are but very little altered) will be readily separated.

425. *Muscular Tissue*.—Although we are accustomed to speak of this tissue as consisting of 'fibres,' yet the ultimate structure of the 'muscular fibre' is very different from that of the simple fibrous tissues already described. When we examine an ordinary Muscle (or piece of 'flesh') with the naked eye, we observe that it is made-up of a number of *fasciculi* or bundles of fibres; which are arranged side-by-side with great regularity, in the direction in which the muscle is to act; and which are united by areolar tissue. These fasci-

culi may be separated into smaller parts, which appear like simple fibres; but when these are examined by the microscope, they are found to be themselves fasciculi, composed of minuter fibres bound-together by delicate filaments of areolar tissue. By carefully separating these, we may obtain the ultimate 'muscular fibre.' This fibre exists under two forms, the *striated* and the *non-striated*. The former is chiefly distinguished by the transversely-striated appearance which it presents, and which is due to an alternation of light and dark spaces along its whole extent; the breadth and distance of these striæ vary, however, in different fibres, and even in different parts of the same fibre, according to its state of contraction or relaxation. Longitudinal striæ are also frequently visible, which are due to a partial separation between the component fibrillæ into which the fibre may be broken-up.—When a fibre of this kind is more closely examined, it is seen to consist of a delicate tubular sheath, quite distinct on the one hand from the areolar tissue which binds the fibres into fasciculi, and equally distinct from the internal substance of the fibre. This membranous tube, which has been termed the *myolemma*, is not perforated either by nerves or capillary vessels; and forms, in fact, a complete barrier between the real elements of Muscular structure, and the surrounding parts. These elements appear to be very minute cylindrical particles with flattened faces of nearly uniform size, and adherent to each other both by their flat surfaces and by their edges. The former adhesion is usually the most powerful; and causes the substance of the fibre, when it is broken-up,

FIG. 325.

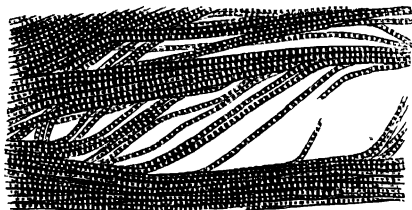

Striated Muscular fibre, separating into fibrillæ.

to present itself in the form of delicate *fibrillæ*, each of which is composed of a single row of the primitive particles (Fig. 325).

The diameter of the fibres varies greatly in different kinds of Vertebrated animals. Its average is greater in Reptiles and Fishes than in Birds and Mammals, and its extremes also are wider; thus its dimensions vary in the Frog from 1-100th to 1-1000th of an inch, and in the Skate from 1-65th to 1-300th; whilst in the Human subject, the average is about 1-400th of an inch, and the extremes about 1-200th and 1-600th.

426. When the fibrillæ are separately examined, under a magnifying power of from 250 to 400 diameters, they are seen to present a cylindrical or slightly-headed form; and their linearly-aggregated particles then appear to be minute *cells*.

We observe the same alternation of light and dark spaces, as when the fibrillæ are united into fibres or into small bundles; but it may be distinctly seen, that each light space is divided by a transverse line; and that there is a pellucid border at the *sides* of the dark spaces, as well as between their contiguous extremities (Fig. 326).

This pellucid border seems to be the cell-wall; the dark space enclosed by it (which is usually bright in the centre) being the cavity of the cell, which is filled with a highly-refracting substance. When the fibril is in a state of relaxation, as seen at *a*, the diameter of the cells is greatest in the longitudinal direction: but when it is contracted, the fibril increases in diameter as it diminishes in length; so that the transverse diameter of each cell becomes equal to the longitudinal diameter, as seen at *b*; or even exceeds it.—

Thus the act of Muscular contraction seems to consist in a change of form in the cells of the ultimate fibrillæ, consequent upon a contraction between the walls of their two extremities; and it is interesting to observe, how very closely it thus corresponds with the contraction of certain Vegetable tissues, of which the component cells are capable of producing movements, when they are irritated, by means of a similar change of form.—The diameter of the ultimate

FIG. 326.



Structure of the ultimate *Fibrillæ* of *Striated Muscular fibre*:—*a*, a fibril in a state of ordinary relaxation; *b*, a fibril in a state of partial contraction.

fibrillæ will of course be subject to variations, in accordance with their contracted or relaxed condition; but it seems to be otherwise tolerably uniform in different animals, being for the most part about 1-10,000th of an inch. It has been observed, however, as high as 1-5000th of an inch, and as low as 1-20,000th, even when the fibre was not put upon the stretch.

427. The 'smooth' or *non-striated* form of Muscular fibre, which is especially found in the walls of the stomach, intestines, bladder, and other similar parts, is composed of flattened bands whose diameter is usually between 2-2000th and 1-3000th of an inch; and these bands are collected into fasciculi, which do not lie parallel with each other, but which cross and interlace. By macerating a portion of such muscular substance, however, in dilute nitric acid (about one part of ordinary acid to three parts of water) for two or three days, it is found that the bands just mentioned may be easily separated into elongated fusiform cells, not unlike woody fibre in shape; each distinguished, for the most part, by the presence of a long staff-shaped nucleus, brought into view by the action of acetic acid. These cells, in which the distinction between cell-wall and cell-contents can by no means be clearly seen, are composed of a soft yellow substance, often containing small pale granules, and sometimes yellow globules of fatty matter. In the coats of the blood-vessels are found cells having the same general characters, but shorter and wider in form; and although some of these approach very closely in their general appearance to epithelium-cells, yet they seem to have quite a different nature, being distinguished by their contractile endowments.

428. In the examination of Muscular Tissue, a small portion may be cut-out with the curved scissors; and this should be torn-up into its component fibres, and these, if possible, should be separated into their fibrillæ, by dissection with a pair of needles, under the simple microscope. The general characters of the striated fibre are admirably shown in the large fibres of the Frog; and by selecting a portion in which these fibres spread themselves out to unite with an aponeurotic expansion, they may often be found so well displayed in a single layer, as not only to exhibit all their characters without any dissection, but also to show their mode of connection with the simple fibrous tissue of which the aponeurosis is formed. As the ordinary characters of the fibre are but little altered by boiling, this process may be had-recourse-to for their more ready separation, especially in the case of the

tongue. The separation of the fibres into their fibrillæ is only likely to be accomplished, in the higher Vertebrata, by repeated attempts, of which the greater number are likely to be unsuccessful; but it may be accomplished with much greater facility in the Eel and other fish, the tenacity of whose muscular tissue is much less. The characters of the fibrillæ are not nearly so well pronounced, however, in the Fish, as in the warm-blooded Vertebrata; and among the latter, the Pig has been found by Mr. Lealand (who has been peculiarly successful in this class of preparations) to yield the best examples. He lays great stress on the freshness of the specimen, which should be taken from the body as soon as possible after death; and when a successful preparation has been made, it should be preserved in Goadby's solution. The shape of the fibres can only be properly seen in cross sections; and these are best made by drying a piece of muscle, so that very thin slices can be cut with a sharp instrument, which, on being moistened again, will resume in great part their original characters.—Striated muscular fibres are readily obtainable from the limbs of Crustacea and of Insects; and their presence is also readily distinguishable in the bodies of Worms, even of very low organisation; so that it may be regarded as characteristic of the Articulated series generally. On the other hand, the Molluscous classes are for the most part distinguished by the non-striation of their fibre; there are, however, two remarkable exceptions, strongly-striated fibre having been found in the *Terebratula* and other *Brachiopods*, and also in many *Polyzoa*. Its presence seems always related to energy and rapidity of movement; whilst the non-striated presents itself, where the movements are slower and feebler in their character.

429. *Nerve-substance*.—Wherever a distinct Nervous system can be made-out, it is found to consist of two very different forms of tissue; namely, the *vesicular*, which are the essential components of the ganglionic centres, and the *tubular*, of which the connecting trunks consist. The 'nerve-vesicles' or 'ganglion-globules' are cells, whose typical form may be regarded as globular; but they often present an extension into one or more long processes, which give them a 'caudate' or a 'stellate' aspect. These processes have been traced into continuity, in some instances, with the axis-cylinders of nerve-tubes; whilst in other cases they seem to inosculate with those of other vesicles. The vesicles are filled with a finely-granular substance, which extends into the prolongations; and they also usually contain pigment-granules, which give

them a reddish or yellowish-brown colour; but these are commonly absent among the lower animals. It is the presence of this pigment, however, which gives to collections of ganglion-globules in the warm-blooded Vertebrata that peculiar hue, which causes it to be known as the *cineritious* or *grey* matter.—Each of the nerve-tubes, on the other hand, of which the trunks are composed, consists, in its most completely-developed form, of a delicate membranous sheath, within which is a hollow cylinder of a material known as the ‘white substance of Schwann,’ whose outer and inner boundaries are marked-out by two distinct lines, giving to each margin of the nerve-tube what is described as a ‘double contour.’ The centre or axis of the tube is occupied by a transparent substance, which is known as the ‘axis-cylinder;’ and there is reason to believe that this last is the essential component of the nervous fibre, and that the hollow cylinder that surrounds it, serves, like the tubular sheath, for its complete isolation. The contents of the membranous envelope are very soft, yielding to slight pressure; and they are so quickly altered by the contact of water or of any liquids that are foreign to their nature, that their characters can only be properly judged of when they are quite fresh.—Besides the proper tubular fibres, however, there are others, known as ‘gelatinous,’ which are considerably smaller than the preceding, and do not exhibit any differentiation of parts. They are flattened, soft, and homogenous in their appearance, and contain numerous nuclear particles, which are brought into view by acetic acid. They can sometimes be seen to be continuous with the axis-cylinders of the ordinary fibres, and also with the radiating prolongations of the vesicles; so that their nervous character, which has been doubted by some anatomists, seems established beyond doubt.—The ultimate distribution of the nerve-fibres may be readily traced in thin vertical sections of the skin, treated with solution of soda. It was formerly supposed that all its papillæ are furnished with nerve-fibres, and minister to sensation; but it is now known that a large proportion (at any rate) of those furnished with loops of blood-vessels (Fig. 329, D), being destitute of nerve-fibres, must have for their special office the production of the epidermis; whilst those which, possessing nerve-fibres, have sensory functions, are usually destitute of blood-vessels. The greater part of the interior of each sensory papilla of the skin, is occupied by a peculiar ‘axile body,’ which seems to be merely a bundle of ordinary fibrous tissue, whercon the nerve-fibre appears to

terminate. The nerve-fibres are more readily seen, however, in the 'fungiform' papillæ of the tongue, to each of which several of them proceed; these bodies, which are very transparent, may be well seen by snipping-off minute portions of the tongue of the Frog; or by snipping-off the papillæ themselves from the surface of the living Human tongue, which can be readily done by a dexterous use of the curved scissors, with no more pain than the prick of a pin would give. The transparency of any of these papillæ is increased, by treating them with a solution of soda.

430. For the sake of obtaining a general acquaintance with the microscopic characters of these principal forms of Nerve-substance, it is best to have recourse to minute nerves and ganglia. The small nerves which are found between the skin and the muscles of the back of the Frog, and which become apparent when the former is being stripped-off, are extremely suitable for this purpose; and if they be treated with strong acetic acid, a contraction of their tubes takes-place, by which the axis-cylinder is forced-out from their cut extremities, so as to be made more apparent than it can be in any other way. The 'gelatinous' fibres are found in the greatest abundance in the Sympathetic nerves; and their characters may be best studied in the smaller branches of that system. So, for the examination of the ganglionic vesicles, and of their relation to the nerve-tubes, it is better to take some minute ganglion as a whole (such as one of the Sympathetic ganglia of the frog, mouse, or other small animal), than to dissect the larger ganglionic masses, whose structure can only be successfully studied by such as are proficient in this kind of investigation. The nerves of the orbit of the eye of Fish, with the ophthalmic ganglion and its branches, which may be very readily got-at in the Skate, and of which the components may be separated without much difficulty, form one of the most convenient objects for the demonstration of the principal forms of nerve-tissue, and especially for the connection of nerve-fibres and ganglionic corpuscles.—No method of preserving the nerve-tissue has yet been devised, which makes it worth while to attempt to mount preparations for the sake of displaying its minute characters; but the general course of the nerve-tubes, and the disposition of the ganglionic vesicles, may be demonstrated in preparations preserved in weak spirit; and when the skin has been injected, the passage of the nerve-fibres to the papillæ can sometimes be traced in vertical sections, mounted as opaque objects, and viewed by reflected

light. The following method, recommended by Mr. J. Lockhart Clarke, for the examination of the structure of the Spinal Cord,* would be equally applicable to that of other large ganglionic masses:—A perfectly fresh cord is to be hardened in strong spirit, so that extremely thin sections can be made with a very sharp knife; and such sections, placed on slips of glass, are to be treated with a mixture of one part of acetic acid and three of spirit, which not only makes the fibrous portion more distinct, but also renders the vesicular portion more transparent. If it be desired to preserve such a section, it should be transferred, after maceration for an hour or two in the mixture of acetic acid and spirit, into pure spirit, in which it should be allowed to remain for about the same space of time; from the spirit it should be transferred to oil of turpentine, which soon expels the spirit, and renders the section perfectly transparent, so that it can be examined with high magnifying powers; and it may then be mounted in Canada balsam in the usual manner.

431. *Circulation of the Blood.*—One of the most interesting spectacles that the microscopist can enjoy, is that which is furnished by the circulation of the blood in the ‘capillary’ blood-vessels, which distribute the fluid through the tissues it nourishes. This, of course, can only be observed in such parts of animal bodies, as are sufficiently thin and transparent to allow of the transmission of light through them without any disturbance of their ordinary structure; and the number of these is very limited. The web of the Frog’s foot is perhaps the most suitable for ordinary purposes, more especially since this animal is to be easily obtained in almost every locality; and the following is the arrangement which the author has found most convenient for the purpose. A piece of thin cork is to be obtained, about 9 inches long and 3 inches wide (such pieces are prepared by the cork-cutters, as soles), and a hole about $\frac{3}{8}$ ths of an inch in diameter is to be cut at about the middle of its length, in such a position that, when the cork is secured upon the stage, this aperture may correspond with the axis of the microscope. The body of the frog is then to be folded in a piece of wet calico, one leg being left free, in such a manner as to confine its movements, but not to press too tightly upon its body; and being then laid down near one end of the cork plate, the free leg is to be extended, so that the foot can be laid over the central aperture. The spreading-out of the foot over the aperture is to be accom-

* See his Memoir on that subject, in “Philos. Transact.,” 1851.

plished, either by passing pins through the edge of the web into the cork beneath, or by tying the ends of the toes by threads to pins stuck into the cork at a small distance from the aperture; the former method is by far the least troublesome, and it may be doubted whether it is really the source of more suffering to the animal than the latter is, the confinement being obviously that which is most felt. A few turns of tape, carried *loosely* around the calico bag, the projecting leg, and the cork, serve to prevent any sudden start; and when all is secure, the cork-plate is to be laid-down upon the stage of the microscope, where a few more turns of the tape will serve to keep it in place. The web being moistened with water (a precaution which should be repeated as often as the membrane exhibits the least appearance of dryness), and an adequate light being reflected through the web from the mirror, this wonderful spectacle is brought into view on the adjustment of the focus (a power of from 75 to 100 diameters being the most suitable for ordinary purposes), provided that no obstacle to the movement of the blood be produced by undue pressure upon the body or leg of the animal. It will not unfrequently be found, however, that the current of blood is nearly or altogether stagnant for a time; this seems occasionally due to the animal's alarm at its new position, which weakens or suspends the action of its heart, the movement recommencing again after the lapse of a few minutes, although no change has been made in any of the external conditions. But if the movement should not renew itself, the tape which passes over the body should be slackened; and if this does not produce the desired effect, the calico envelope must also be loosened. When everything has once been properly adjusted, the animal will often lie for hours without moving, or will only give an occasional twitch.—The movement of the blood will be distinctly seen by that of the corpuscles, which course after one another through the network of capillaries that intervenes between the smallest arteries and the smallest veins; in those tubes that pass most directly from the veins to the arteries, the current is always in the same direction; but in those which pass-across between these, it may not unfrequently be seen that the direction of the movement changes from time to time. The larger vessels (Fig. 327), with which the capillaries are seen to be connected, are almost always *veins*, as may be known from the direction of the flow of blood in them from the branches (*b, b*) towards their trunks (*a*); the *arteries*, whose ultimate subdivisions discharge themselves into the capillary network, are for the

most part restricted to the immediate borders of the toes. When a power of 200 or 250 diameters is employed, the visible area is of course greatly reduced; but the individual vessels

FIG. 327.

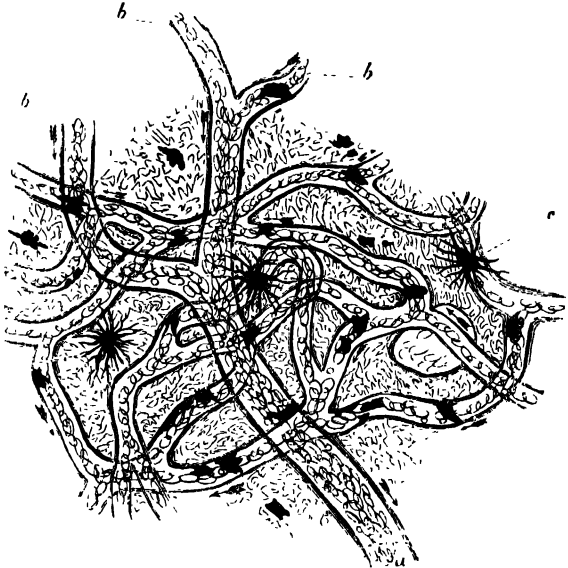

Capillary circulation in a portion of the web of a *Frog's* foot; *a*, trunk of vein; *b*, *b*, its branches; *c*, *c*, pigment cells.

and their contents are much more plainly seen; and it may then be observed, that whilst the red corpuscles flow at a very rapid rate along the centre of each tube, the colourless corpuscles which are occasionally discernible, move slowly in the clear stream near its margin.

432. The circulation may also be displayed in the *tongue* of the Frog, by laying the animal down on its back, with its head close to the hole in the cork-plate, and, after securing the body in this position, drawing-out the tongue with the forceps, and fixing it on the other side of the hole with pins. This method, however, is so much more distressing to the animal,

that its employment seems scarcely justifiable for the mere purpose of display; and nothing but some anticipated benefit to science, can justify the laying-open of the body of the living animal, for the purpose of examining the circulation in its lungs or mesentery.—The *tadpole* of the Frog, when sufficiently young, furnishes a good display of the circulation in its tail; and the difficulty of keeping it quiet during the observation may be overcome, by gradually mixing some hot water with that in which it is swimming, until it becomes motionless; this usually happens when it has been raised to a temperature between 100 and 110°; and notwithstanding that the muscles of the body are thrown into a state of spasmodic rigidity by this treatment, the heart continues to pulsate, and the circulation is maintained. The *larva of the Water-Newt*, when it can be obtained, furnishes a most beautiful display of the circulation, both in its external gills, and in its delicate feet. It may be enclosed in a large aquatic box or in a shallow cell, gentle pressure being made upon its body, so as to impede its movements, without stopping the heart's action.—The circulation may also be seen in the tails of small fish, such as the *Minnow* or *Stickle-back*, by confining these animals in tubes, or in shallow cells, or in a large aquatic box; but although the extreme transparency of these parts adapts them well for this purpose in one respect, yet the comparative scantiness of their bloodvessels prevents them from being as suitable as the Frog's web in another not less important particular.—One of the most beautiful of all displays of the circulation, however, is that which may be seen upon the yolk-bag of young Fish (such as the trout) soon after they have been hatched; and as it is their habit to remain almost entirely motionless at this stage of their existence, the observation can be made with the greatest facility by means of the zoophyte-trough, provided that the subject of it can be obtained. Now that the artificial breeding of these fish is largely practised for the sake of stocking fish-ponds, there can seldom be much difficulty in procuring specimens at the proper period. The store of yolk which the yolk-bag supplies for the nutrition of the embryo, not being exhausted in the Fish (as it is in the bird) previously to the hatching of the egg, this bag hangs-down from the belly of the little creature on its emersion; and continues to do so until its contents have been absorbed into the body, which does not happen for some little time afterwards. And the blood is distributed over it in copious streams, partly that it may draw into itself fresh nutritive

material, and partly that it may be subjected to the aerating influence of the surrounding water.

433. *Injected Preparations.*—Next to the circulation of the blood in the living body, the varied distribution of the Capillaries in its several organs, as shown by means of ‘injections’ of colouring matter thrown into their principal vessels, is one of the most interesting subjects of microscopic examination. The art of making successful preparations of this kind, is one in which perfection can usually be attained only by long practice, and by attention to a great number of minute particulars; and better specimens may be obtained therefore, from those who have made it a business to prepare them, than are likely to be prepared by amateurs for themselves. For this reason, no more than a general account of the process will be here offered; the minute details which need to be attended-to, in order to attain successful results, being readily accessible elsewhere to such a desire to put it in practice.*—The colouring-matter which is altogether most suitable when only one set of vessels is to be injected, is Chinese vermilion. This, however, as commonly sold, contains numerous particles of far too large a size; and it is necessary first to reduce it to a greater fineness by continued trituration in a mortar (an agate or a steel mortar is the best) with a small quantity of water, and then to get-rid of the larger particles by a process of ‘levigation,’ exactly corresponding to that by which the particles of coarse sand, &c., are separated from the Diatomaceæ (p. 338). The fine powder thus obtained, ought not, when examined under a magnifying power of 200 diameters, to exhibit particles of any appreciable dimensions. The ‘size’ or ‘gelatine’ should be of a fine and pure quality, and should be of sufficient strength to form a tolerably-firm jelly when cold, whilst quite limpid when warm. It should be strained, whilst hot, through a piece of new flannel; and great care should be taken to preserve it free from dust, which may best be done by putting it into clean jars, covering its surface with a thin layer of alcohol. The proportion of levigated vermilion to be mixed with it for injection, is about 2oz. to a pint; and this is to be stirred in the melted size, until the two are thoroughly incorporated, after which the mixture should be strained through muslin. The injection is thrown into the

* See especially the article ‘Injection,’ in the “Micrographic Dictionary;” Dr. Beale’s treatise on “The Microscope, and its application to Clinical Medicine,” chap. viii.; and M. Robin’s work, “Du Microscope et des Injections.” (Paris, 1849.)

vessels by means of a brass syringe expressly constructed for the purpose, which has several jet-pipes of different sizes, adapted to the different dimensions of the vessels to be injected; and these should either be furnished with a stop-cock to prevent the return of the injection when the syringe is withdrawn, or a set of small corks of different sizes should be kept in readiness, with which they may be plugged. The pipe should be inserted into the cut end of the trunk which is to be injected, and should be tied therein by a silk thread. In injecting the vessels of fish, mollusks, &c., the softness of the vessels renders them liable to break in the attempt to tie them; and it is therefore better for the operator to satisfy himself with introducing a pipe as large as he can insert, and with passing it into the vessel as far as he can without violence. All the vessels from which the injection might escape, should be tied, and sometimes it is better to put a ligature round a part of the organ or tissue itself; thus, for example, when a portion of the intestinal tube is to be injected through its branch of the mesenteric artery, not only should ligatures be put round any divided vessels of the mesentery, but the cut ends of the intestinal tube should be firmly tied.—The operation should either be performed when the body or organ is as fresh as possible, or after the expiry of sufficient time to allow the *rigor-mortis* to pass-off, the presence of this being very inimical to the success of the injection. The part should be thoroughly warmed, by soaking in warm water for a time proportionate to its bulk; and the injection, the syringe, and the pipes should also have been subjected to a temperature sufficiently high to ensure the free flow of the liquid. The force used in pressing-down the piston should be very moderate at first; but should be gradually increased as the vessels become filled; and it is better to keep-up a steady pressure for some time, than to attempt to distend them by a more powerful pressure, which will be certain to cause extravasation. This pressure should be maintained* until the injection begins to flow from the large veins, and the tissue is thoroughly reddened; and if one syringe-full of injection after another be required for this purpose, the return of the injection should be prevented by stopping the nozzle of the jet-pipe when the syringe is removed for re-filling. When the injection has been com-

* A simple mechanical arrangement for this purpose, by which the fatigue of maintaining this pressure with his hand is saved to the operator, is described in the "Micrographic Dictionary," p. 354.

pleted, any openings by which it can escape should be secured, and the preparation should then be placed for some hours in cold water, for the sake of causing the size to 'set.'*

434. Although no injections look so well by reflected light, as those which are made with vermilion, yet other colouring substances may be advantageously employed for particular purposes. Thus the yellow chromate of lead, which is precipitated when a solution of acetate of lead is mixed with a solution of chromate of potass, is an extremely fine powder, which 'runs' with great facility in an injection, and has the advantage of being very cheaply prepared. The best method of obtaining it, is to dissolve 200 grains of acetate of lead and 105 grains of chromate of potass in separate quantities of water, to mix these, and then, after the subsidence of the precipitate, to pour-off the supernatant fluid, so as to get-rid of the acetate of potash which it contains, since this is apt to corrode the walls of the vessels, if the preparation be kept moist. The solutions should be mixed cold, and the precipitate should not be allowed to dry before being incorporated with the size, four ounces of which will be the proportion appropriate to the quantity of the colouring-substance produced by the above process.—The same materials may be used in such a manner that the decomposition takes-place within the vessels themselves, one of the solutions being thrown-in first, and then the other; and this process involves so little trouble or expense, that it may be considered the best for those who are novices in the operation, and who are desirous of perfecting themselves in the practice of the easier methods, before attempting the more costly. By M. Doyère, who first devised this method, it was simply recommended to throw-in saturated solutions of the two salts, one after the other; but Dr. Goadby, who has had much experience in the use of it, advises that gelatine should be employed, in the proportion of 2 oz. dissolved in 8 oz. of water, to 8 oz. of the saturated solutions of each salt. This method answers very well for preparations that are to be mounted dry; but for such as are to be preserved in fluid, it is subject to the disadvantage of retaining in the vessels the solution of acetate of potash, which

* The kidney of a sheep or pig is a very advantageous organ for the learner to practise-on; and he should first master the filling of the vessels from the arterial trunk alone, and then, when he has succeeded in this, he should fill the tubuli uriniferi with white injection, before sending coloured injection into the renal artery. The entire systemic circulation of small animals, as mice, rats, frogs, &c., may be injected from the aorta; and the pulmonary vessels from the pulmonary artery.

exerts a gradual corrosive action upon them. Dr. Goadby has met this objection, however, by suggesting the substitution of nitrate for acetate of lead; the resulting nitrate of potash having rather a preservative than a corrosive action on the vessels.—When it is desired to inject two or more sets of vessels (as the arteries, veins, and gland-ducts) of the same preparation, different colouring substances should be employed. For a *white* injection, the carbonate of lead (prepared by mixing solutions of acetate of lead and carbonate of soda, and pouring-off the supernatant liquid when the precipitate has fallen) is the best material. No *blue* injections can be much recommended, as they do not reflect light well, so that the vessels filled with them seem almost black; the best is freshly-precipitated Prussian blue (formed by mixing solutions of persulphate of iron and ferrocyanide of potassium), which, to avoid the alteration of its colour by the free alkali of the blood, should be triturated with its own weight of oxalic acid and a little water, and the mixture should then be combined with size, in the proportion of 146 grains of the former to 4 oz. of the latter.

435. Injected preparations may be preserved either dry or in fluid. The former method is well suited to sections of many solid organs, in which the disposition of the vessels does not sustain much alteration by drying; for the colours of the vessels are displayed with greater brilliancy than by any other method, when such slices, after being well dried, are moistened with turpentine and mounted in Canada balsam. But for such an injection as that shown in Fig. 328, in which the form and disposition of the intestinal *villi* would be completely altered by drying, it is indispensable that the preparation should be mounted in fluid, in a cell deep enough to prevent any

FIG. 328.

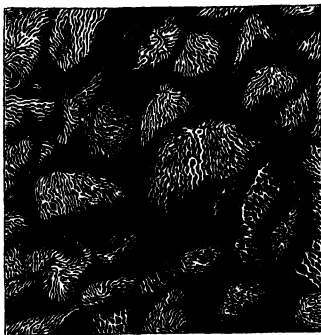

Villi of Small Intestine of Monkey.

pressure on its surface. Either Goadby's solution or weak spirit answers the purpose very well.

436. A well-injected preparation should have its vessels completely filled through every part; the particles of the colouring matter should be so closely compacted together, that they should not be distinguishable unless carefully looked-for; and there should be no patches of pale uninjected tissue. Still, although the beauty of a specimen as a microscopic object is much impaired by a deficiency in the filling of its vessels, yet to the anatomist the disposition of the vessels will be as apparent when they are only filled in part, as it is when they are fully distended; and imperfectly-injected capillaries are better seen, when thin sections are mounted as transparent objects, than are such as have been completely filled.

FIG. 329.

A

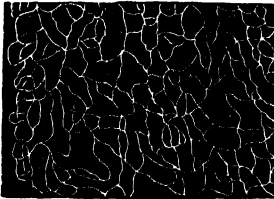
Capillary network around *Fat-cells*.

B

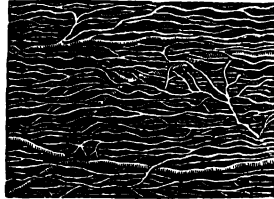
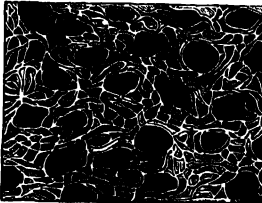
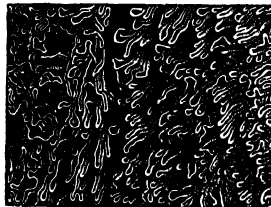
Capillary network of *Muscle*.Distribution of Capillaries
in *Mucous Membrane*.Distribution of Capillary blood-vessels
in *Skin of Finger*.

437. A relation may generally be traced between the disposition of the Capillary vessels, and the functions they are destined to subserve; but that relation is obviously (so to

speak) of a mechanical kind; the arrangement of the vessels not in any way determining the function, but merely administering to it, like the arrangement of water- or gas-pipes in a manufactory. Thus in Fig. 329 A, we see that the capillaries of fatty tissue are disposed in a network with rounded meshes, so as to distribute the blood among the fat-cells (§ 422); whilst at B we see the meshes enormously elongated, so as to permit muscular fibres to lie in them. Again, at C we observe the disposition of the capillaries around the orifices of the follicles of a mucous membrane; whilst at D we see the looped arrangement which exists in the papillary surface of the skin, and which is subservient to the nutrition of the epidermis and to the activity of the sensory nerves.

438. In no part of the circulating apparatus, however, does the disposition of the capillaries present more points of interest, than it does in the Respiratory organs. In *Fishes*, the respiratory surface is formed by an outward extension into fringes of *gills*, each of which consists of an arch with straight laminae hanging-down from it; and every one of these laminae (Fig. 330) is furnished with a double row of leaflets, which is most minutely supplied with bloodvessels, their network (as seen at A) being so close, that its meshes (indicated by the dots in the figure) cover less space than the vessels themselves. The gills of Fish are not ciliated on their surface, like those of Mollusks and of the larva of the Water-newt; the

FIG. 330.

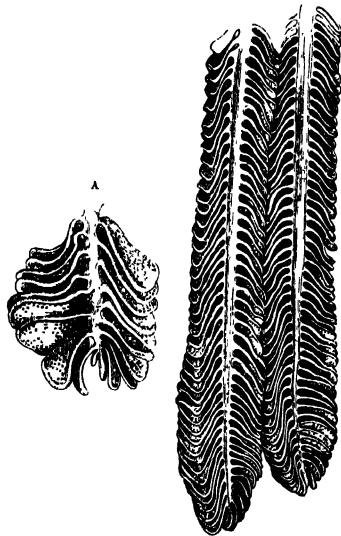

Two branchial processes of the *Gill of the Eel*, showing the branchial lamellae:—
A, portion of one of these processes enlarged, showing the capillary network of the lamellae.

necessity for such a mode of renewing the fluid in contact with them, being superseded by the muscular apparatus with which the gill-chamber is furnished.—But in *Reptiles*, the respiratory surface is formed by the walls of an internal cavity, that of the *lungs*: these organs, however, are constructed on a plan very different from that which they present in higher *Vertebrata*, the great extension of surface which is effected in the latter by the minute subdivision of the cavity, not being here necessary. In the Frog (for example) the cavity of each lung is undivided; its walls, which are thin and membranous at the lower part, there present a simple smooth expanse; and it is only at the upper part, where the extensions of the tracheal cartilage form a network over the interior, that its surface is depressed into *sacculi*, whose lining is crowded with bloodvessels (Fig. 331). In this manner,

FIG. 331.

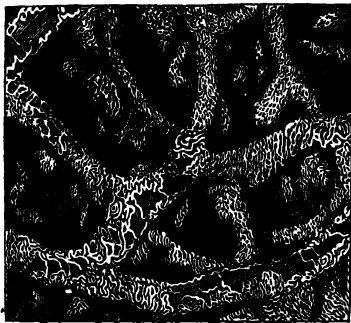

Interior of upper part of Lung of Frog.

a set of air-cells is formed in the thickness of the upper wall of the lung, which communicates with the general cavity, and very much increases the surface over which the blood comes into relation with the air; but each air-cell has a capillary network of its own, which lies on one side against its wall, so as only to be exposed to the air on its free surface. In the elongated lung of the Snake, the same general arrangement prevails; but the cartilaginous reticulation of its upper part projects much further into the cavity, and encloses in its meshes (which are usually square, or nearly so) several layers of air-cells, which communicate, one through another, with the general cavity.—The structure of the lungs of *Birds* presents us with an arrangement of a very different kind, the purpose of which is to expose a very large amount of capillary surface to the influence of the air. The entire mass of each may be considered as subdivided into an immense number

of 'lobules' or 'lunglets' (Fig. 332), each of which has its own bronchial tube (or subdivision of the windpipe), and its own system of blood-vessels, which have very little communication with those of other lobules. Each lobule has a central

FIG. 332.

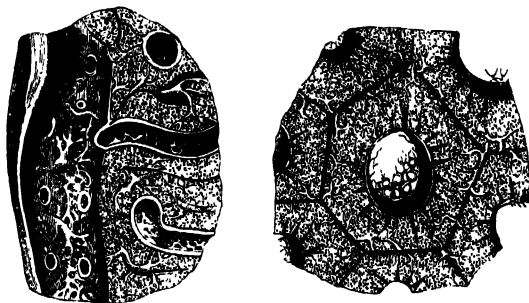

Interior structure of *Lung of Fowl*, as displayed by a section, A, passing in the direction of a bronchial tube, and by another section, B, cutting it across.

cavity, which closely resembles that of a Frog's lung in miniature; having its walls strengthened by a network of cartilage derived from the bronchial tube, in the interstices of which are openings leading to sacculi in their substance. But each of these cavities is surrounded by a solid plexus of blood-vessels, which does not seem to be covered by any limiting membrane, but which admits air from the central cavity freely between its meshes; and thus its capillaries are in immediate relation with air on all sides, a provision that is obviously very favourable to the complete and rapid aeration of the blood they contain.—In the lung of *Man* and *Mammals*, again, the plan of structure differs from the foregoing, though the general effect of it is the same. For the whole interior is divided-up into minute air-cells, which freely communicate with each other, and with the ultimate ramifications of the air-tubes into which the trachea (windpipe) subdivides; and the network of blood-vessels (Fig. 333) is so disposed in the partitions between these cavities, that the blood is exposed to the air on both sides. It has been calculated that the number

of these air-cells grouped around the termination of each air-tube in Man, is not less than 18,000; and that the total number in the entire lungs is *six hundred millions*.

FIG. 333.

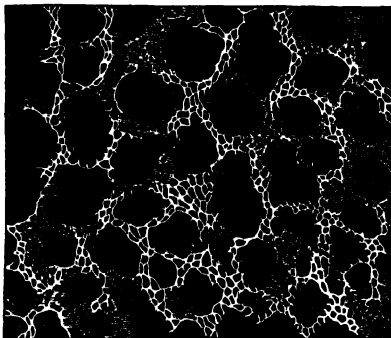

Arrangement of the Capillaries of the air-cells of the *Human Lung*.

439. The following list of the parts of the bodies of Vertebrata, of which Injected preparations are most interesting as Microscopic objects, may be of service to those who may be inclined to apply themselves to their production.

—*Alimentary Canal*; Stomach, showing the orifices of the gastric follicles, and

the rudimentary villi near the pylorus; Small Intestine, showing the villi and the orifices of the follicles of Lieberkuhn, and at its lower part the Peyerian glands; Large Intestine, showing the various glandular follicles:—*Respiratory Organs*; Lungs of Mammals, Birds, and Reptiles; Gills and Swimming-bladder of Fish:—*Glandular Organs*; Liver, Gall-bladder, Kidney, Parotid:—*Generative Organs*; Oviduct of Bird and Frog; Mammalian Placenta; Uterine and Fœtal Cotyledons of Ruminants:—*Organs of Sense*; Iris, Choroid, and Ciliary processes of Eye, Pupillary Membrane of fœtus; Papillæ of Tongue; Mucous membrane of Nose; Papillæ of Skin of finger:—*Tegumentary Organs*; Skin of different parts, hairy and smooth, with vertical sections showing the vessels of the Hair-follicles, Sebaceous glands, and Papillæ; Matrix of nails, hoofs, &c.:—*Tissues*; Fibrous, Muscular, Adipose, Sheath of Tendon.

440. *Development*.—The study of the Embryological development of Vertebrated animals has been pursued of late years with great zeal and success by the assistance of the Microscope; but as this is a department of enquiry which

needs for its successful pursuit a thoroughly-scientific culture, and is only likely to be taken-up by a professed Physiologist, no good purpose seems likely to be served by here giving such an imperfect outline of the process, as could alone be introduced into a work like the present; and the reader who may desire information upon it, will find no difficulty in obtaining this through systematic treatises on Physiology.*

* The Author takes the liberty of referring to his "Principles of Comparative Physiology," 4th Ed., chap. xi., as containing a general view of the whole subject, with references to the principal sources of more detailed information.

CHAPTER XIX.

APPLICATIONS OF THE MICROSCOPE TO GEOLOGICAL INVESTIGATION.

441. THE utility of the Microscope is by no means limited to the determination of the structure and actions of the Organized beings at present living on the surface of the earth; for a vast amount of information is afforded by its means to the geological enquirer, not only with regard to the minute characters of the many Vegetable and Animal remains that are entombed in the successive strata of which its crust is composed, but also with regard to the essential nature and composition of many of those strata themselves.—We cannot have a better example of its value in both these respects, than that which is afforded by the results of microscopic examination of *lignite* or fossilized wood, and of ordinary *coal*, which there is every reason to regard as a product of the decay of wood.

442. Specimens of *Fossilized Wood*, in a state of more or less complete preservation, are found in numerous strata of very different ages,—more frequently, of course, in those whose materials were directly furnished by the dry land, and were deposited in its immediate proximity, than in those which were formed by the deposition of sediments at the bottom of a deep ocean. Generally speaking, it is only when the wood is found to have been penetrated by *silex*, that its organic structure is well preserved; but instances occur every now and then, in which penetration by *carbonate of lime* has proved equally favourable. In either case, transparent sections are needed for the full display of the organization; but such sections, though made with great facility when lime was the fossilizing material, require much labour and skill when *silex* has to be dealt-with. Occasionally, however, it has happened that the infiltration has filled the cavities of the cells and vessels, without consolidating their walls; and as the latter have undergone decay without being replaced by any cementing material, the lignite, thus composed of the internal ‘casts’

of the woody tissues, is very friable, its fibres separating from each other like those of asbestos; and their laminæ split-apart with a knife, or isolated fibres separated by rubbing-down between the fingers, exhibit the characters of the woody structure extremely well, when mounted in Canada balsam.— Generally speaking, the lignites of the Tertiary strata present a tolerably-close resemblance to the wood of the existing period; thus the ordinary structure of *Dicotyledonous* and *Monocotyledonous* stems, may be discovered in such lignites in the utmost perfection; and the peculiar modification presented by *Coniferous* wood, is also most distinctly exhibited (Fig. 171). As we descend, however, through the strata of the Secondary period, we more and more rarely meet with the ordinary dicotyledonous structure; and the lignites of the earliest deposits of these series are, almost universally, either gymnosperms or palms.* Descending into the Palæozoic series, we are presented in the vast *Coal* formations of our own and other countries, with an extraordinary proof of the prevalence of a most luxuriant vegetation in a comparatively-early period of the world's history; and the microscope lends the geologist essential assistance, not only in determining the nature of much of that vegetation, but also in demonstrating, what had been suspected on other grounds, that Coal itself is nothing else than a mass of decomposed vegetable matter, chiefly derived from the decay of *Coniferous* wood. The determination of the characters of the *Ferns*, *Sigillariæ*, *Lepidodendra*, *Calamites*, and other kinds of vegetation whose forms are preserved in the shales and sandstones that are interposed between the strata of coal, must be chiefly based on their external characters; since it is very seldom that any of these specimens present any such traces of minute internal structure, as can be subjected to microscopic elucidation. But notwithstanding the general absence of any definite *form* in the masses of decomposed wood of which Coal itself consists (these having apparently been reduced to a pulpy state by decay, before the process of consolidation by pressure, aided perhaps by heat, commenced), the traces of *structure* revealed by the Microscope, are sufficient not only to determine its vegetable origin, but, in some cases to justify the Botanist in assigning the characters of the vegetation from which it must have been derived. Different specimens of Coal exhibit these structural characters in very different degrees of distinctness;

* Under this head are included the *Cycadææ*, along with the ordinary *Coniferæ* or pine and fir tribe.

but they uniformly indicate, with a clearness proportionate to their distinctness, that such vegetation must have been *Coniferous* in its nature, and that it probably approximated most nearly to that group of existing *Coniferæ*, to which the *Araucariæ* belong. These inferences are based upon the fact, that the woody structure consists of woody fibres without interposed vessels; upon the presence of glandular dots on the woody fibres; and upon the peculiar arrangement of these dots in two or more rows, alternating one with another (§§ 231, 238).

443. In examining the structure of Coal, various methods may be followed. Of those kinds which have sufficient tenacity, thin sections may be made; but the opacity of the substance requires that such sections should be ground extremely thin, before they become transparent; and its friability renders this process one of great difficulty. Any section must either cross the woody tissue transversely, so that the appearance it presents will resemble that of Fig. 170; or it must traverse it vertically, in which case the fibrous structure will be brought into view, either as in Fig. 171, or as in Fig. 172; or it must pass in an intermediate direction. The following method, which would seem not only to be more simple, but also to give more satisfactory results, is recommended by the authors of the "Micrographic Dictionary" (p. 150):—"The coal is macerated for about a week in a solution of carbonate of potass; at the end of that time, it is possible to cut tolerably-thin slices with a razor. These slices are then placed in a watch-glass with strong nitric acid, covered, and gently heated; they soon turn brownish, then yellow, when the process must be arrested by dropping the whole into a saucer of cold water, or else the coal would be dissolved. The slices thus treated appear of a darkish amber-colour, very transparent, and exhibit the structure, when existing, most clearly. The specimens are best preserved in glycerine, in cells; we find that spirit renders them opaque, and even Canada balsam has the same effect."—When the coal is so friable, that no sections can be made of it by either of these methods, it may be ground to fine powder, and the particles may then, after being mounted in Canada balsam, be subjected to microscopic examination: the results which this method affords, are by no means satisfactory in themselves; but they will often enable the organic structure to be sufficiently determined, by the comparison of the appearances presented by such fragments, with those which are more distinctly exhibited elsewhere. Valuable information may

often be obtained, too, by treating the ash⁴ of an ordinary coal-fire in the same manner, or (still better) by burning to a white ash a specimen of coal that has been previously boiled in nitric acid, and then carefully mounting the ash in Canada balsam; for mineral casts of vegetable cells and fibres may often be distinctly recognized in such ash; and such casts are not unfrequently best afforded by samples of coal, in which the method of section is least successful in bringing to light the traces of organic structure, as is the case, for example, with the 'anthracite' of Wales.*

444. Passing-on, now to the Animal kingdom, we shall first cite some parallel cases in which the essential nature of deposits that form a very important part of the Earth's crust, has been determined by the assistance of the microscope; and shall then select a few examples of the most important contributions which it has afforded, to our acquaintance with types of Animal life long since extinct.—It is an admitted rule in Geological science, that the past history of the Earth is to be interpreted, so far as may be found possible, by the study of the changes which are still going-on. Thus, when we meet with an extensive stratum of fossilized *Diatomacea* (§ 191) in what is now dry land, we can entertain no doubt that this siliceous deposit originally accumulated either at the bottom of a fresh-water lake, or beneath the waters of the ocean; just as such deposits are formed at the present time, by the production and death of successive generations of these bodies, whose indestructible casings accumulate in the lapse of ages, so as to form layers whose thickness is only limited by the time during which this process has been in action (§ 190). In like manner, when we meet with a limestone-rock entirely composed of the calcareous shells of *Foraminifera*, some of them entire, others broken-up into minute particles, we interpret the phenomenon by the fact, that the dredgings obtained from certain parts of the ocean-bottom consist almost entirely of remains of existing *Foraminifera*, in which entire shells, the animals of which may be yet alive, are mingled with the *debris* of others that have been reduced by the action of the waves to a fragmentary state.† Now in the fine white

* See Prof. Quekett's Memoir on the Minute Structure of the Torbane-hill Mineral, in "Transact. of the Microsc. Societ.," Ser. 2, vol. ii. p. 41, *et seq.*

† Such a deposit, consisting chiefly of *Orbitolites* (§ 287), is at present in the act of formation on certain parts of the shores of Australia, as the Author is informed by Mr. J. Beete Juke.; thus affording the exact parallel to the stratum of *Orbitolites* (belonging, as the Author's investigations have led him to believe, to the very same species) that forms part of the 'Calcaire Grossier' of the Paris basin.

mud which is brought-up from almost every part of the sea-bottom of the Levant, where it forms a stratum that is con-

FIG. 334.

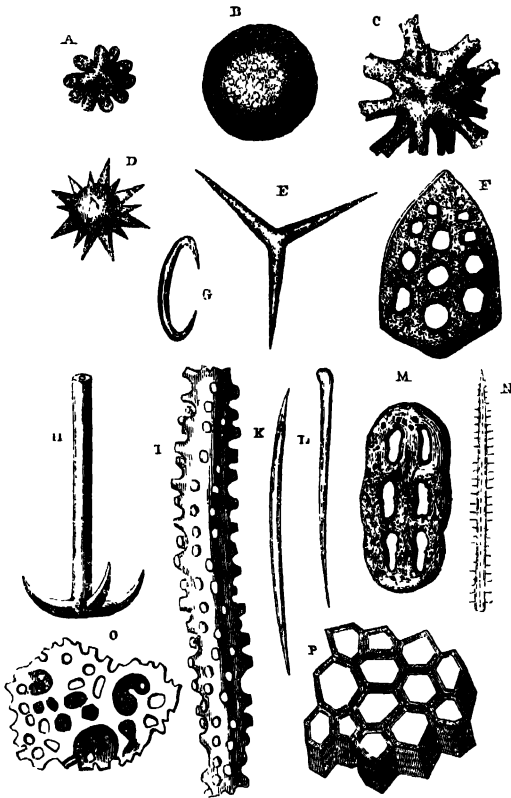

Microscopic Organisms in *Levant Mud*:—A, D, siliceous spicules of *Tethya*; B, H, spicules of *Geodia*; C, Sponge-spicule (unknown); E, calcareous spicule of *Grantia*; F, G, M, O, portions of calcareous skeleton of Echinodermata; H, I, calcareous spicule of *Gorgonia*; K, L, N, siliceous spicules of *Halichondria*; P, portion of prismatic layer of shell of Pinna.

tinually undergoing a slow but steady increase in thickness, the microscopic researches of Prof. Williamson* have shown that not only are there multitudes of minute remains of living organisms, both animal and vegetable, but that it is entirely or almost wholly composed of such remains. Among these were about 26 species of Diatomacæ (siliceous), 8 species of Foraminifera (calcareous), and a miscellaneous group of objects (Fig. 334), consisting of calcareous and siliceous spicules of Sponges and Gorgoniæ, and of fragments of the calcareous skeletons of Echinoderms and Mollusks.

FIG. 335.

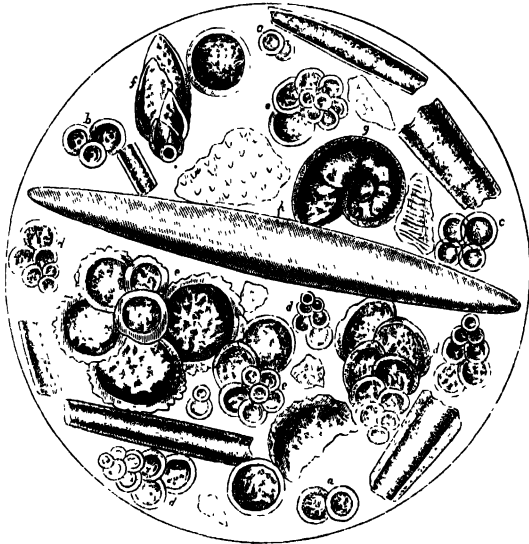

Microscopic Organisms in *Chalk* from Gravesend;—*a, b, c, d*, *Textularia globulosa*; *e, e, e*, *Rotalia aspera*; *f*, *Textularia aculeata*; *g*, *Planularia hexas*; *h*, *Navicula*.

445. Now almost exactly the same collection of forms, with the exception of the siliceous Diatomacæ, is found in many

* "Memoirs of the Manchester Literary and Philosophical Society," vol. viii.

parts of the 'Calcaire Grossier' of the Paris basin, as well as in other extensive deposits of the same early tertiary period. And there is little doubt that a large proportion of the great Cretaceous (chalk) formation has a like composition; for many parts of it consist in great part of the minuter kinds of Foraminifera, whose shells are imbedded in a mass of apparently amorphous particles, many of which, nevertheless, present indications of being the worn fragments of similar shells, or of larger calcareous organisms. In the Chalk of some localities, Foraminifera constitute the principal part of the minute organisms which can be recognized with the microscope (Figs. 335, 336); in other instances, the disintegrated prisms

FIG. 336.

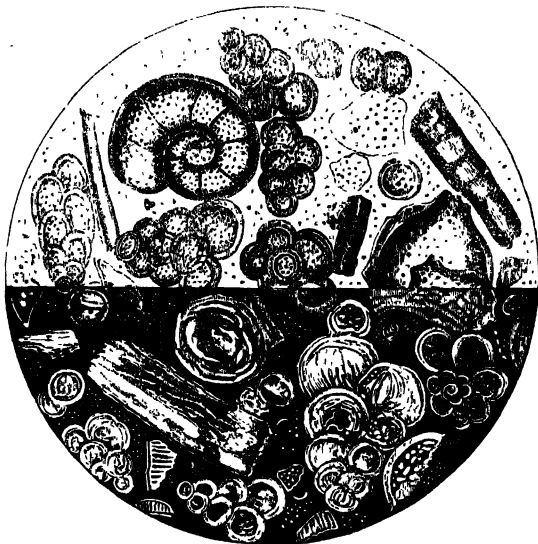

Microscopic Organisms in *Chalk* from Meudon; partly seen as opaque, and partly as transparent objects.

of *Pinna* (§ 336) or other large shells of the like structure (as *Inoceramus*) constitute the great bulk; whilst in other cases, again, the chief part is made-up of the shells of *Cytherina*, a

marine form of Entomostracous Crustacean (§ 367). Different specimens of Chalk vary greatly in the proportion which the distinctly-organic remains bear to the amorphous particles, and which the different kinds of the former bear to each other; and this is quite what might be anticipated, when we bear in mind the predominance of one or another tribe of animals or plants in the several parts of a large area. True Chalk seems to differ from the Levant Mud, in the small proportion which the siliceous remains of Diatomaceæ bear, in the former, to that which is mingled in the latter with the calcareous shells of Foraminifera, &c.; and it seems doubtful to what extent they were present in the seas of that epoch. Such remains are found in abundance, however, forming marly strata which alternate with those of a chalky nature, in the South of Europe and the North of Africa (Fig. 101); and it is surmised by Prof. Ehrenberg, that the layers of *flint* which the British Chalk contains, have been derived by some metamorphic process from similar layers of siliceous Diatomaceæ which have disappeared. It is now certain, however, that the deposits referred to by Prof. Ehrenberg are of an age later than that of the great Chalk formation; so that little support is furnished by their phenomena to his hypothesis. But whatever may have been the origin of the siliceous material, it may be stated as a fact beyond all question, that nodular flints and other analogous concretions (such as agates) may generally be considered as fossilized Sponges or Alcyonian Zoophytes; since not only are their external forms and their superficial markings often highly characteristic of those organisms, but, when sections of them are made, sufficiently thin to be transparent, a spongy texture may be most distinctly recognized in their interior.* It is curious that many such sections contain well-preserved specimens of *Xanthidia*, which are Desmidiaceæ whose divided body is covered with long spinous projections, often cleft, and sometimes furnished with hooks at their extremities; and we occasionally also find upon their surface, or even imbedded in their substance, Foraminiferous shells (especially *Rotaliæ*), in which not only the substance of the shell has undergone silicification, but also that of the soft animal body, the shrunken form of which may be recognized in the dark carbonaceous hue imparted to the central portion of the silex which fills each chamber.

446. In examining Chalk or other similar mixed aggregations, whose component particles are easily separable from

* See Mr. Bowerbank's Memoirs in the "Transact. of the Geolog. Societ.," 1841, and in the "Ann. of Nat. Hist.," 1st Ser., vols. vii., x.

each other, it is desirable to separate, with as little trouble as possible, the larger and more definitely-organized bodies, from the minute amorphous particles; and the mode of doing this will depend upon whether we are operating upon the large or upon the small scale. If the former, a quantity of soft chalk should be rubbed to powder with water, by means of a soft brush; and this water should then be proceeded-with, according to the method of levigation already directed for separating the Diatomaceæ (§ 192). It will usually be found that the first deposits contain the larger Foraminifera, fragments of shell, &c., and that the smaller Foraminifera and Spongespicules fall next; the fine amorphous particles remaining diffused through the water after it has been standing for some time, so that they may be poured-away. The organisms thus separated should be dried, and mounted in Canada balsam.—If the smaller scale of preparation be preferred, as much chalk scraped fine as will lie on the point of a knife, is to be laid on a drop of water on the glass slide, and allowed to remain there for a few seconds; the water, with any particles still floating on it, should then be removed; and the sediment left on the glass should be dried and mounted in balsam.—For examining the structure of flints, such chips as may be obtained with a hammer will commonly serve very well: a clear translucent flint being first selected, and the chips that are obtained being soaked for a short time in turpentine (which increases their transparency), those which show organic structure, whether Sponge-tissue or Xanthidia, are to be selected and mounted in Canada balsam. The most perfect specimens of sponge-structure, however, are only to be obtained by slicing and polishing,—a process which is best performed by the lapidary.

447. There are various other deposits, of less extent and importance than the great Chalk-formation, which are, like it, composed in great part of microscopic organisms, chiefly minute Foraminifera; and the presence of animals of this group may be recognized, by the assistance of this instrument, in sections of calcareous rocks of various dates, whose chief materials seem to have been derived from Corals, Encrinite-stems, or Molluscous shells. Thus in the 'Crag' formation (tertiary) of the eastern coast of England, the greater portion of which is perceived by the unassisted eye to be composed of fragments of Shells, Corals (or rather Polyzoaria, § 325), and Echinodermata, the microscope enables us to discover Foraminifera, minute fragments of shells and corals, and spicules of Sponges; the aggregate being such as is at present in

process of formation on many parts of our shores, and having been, therefore, in all probability, a 'littoral' formation, whilst the Chalk (with other formations chiefly consisting of Foraminifera) was deposited at the bottom of deeper waters. Many parts of the Oolitic (secondary) formation have an almost identical character, save that the forms of organic life give evidence of a different age; and in those portions which exhibit the 'roe-stone' arrangement from which the rock derives its name (such as is beautifully displayed in many specimens of Bath-stone and Portland-stone), it is found by microscopic examination of transparent sections, that each rounded concretion is composed of a series of concentric spheres enclosing a central nucleus, which nucleus is often a Foraminiferous shell. In the Carboniferous (palæozoic) limestone, again, well-preserved specimens of Foraminifera present themselves; and there are certain bands of limestone of this epoch in Russia, varying in thickness from fifteen inches to five feet, and frequently repeated through a vertical depth of two hundred feet, which are almost entirely composed of Foraminiferous shells belonging to a genus now extinct, the *Fusulina*.

448. It is not only, however, in the condition of organisms of microscopic size, that the Foraminifera have contributed in an important degree to the formation of the solid crust of the earth; for the Nummulitic limestone,*—which forms a band, often 1800 miles in breadth, and frequently of enormous thickness, that may be traced from the Atlantic shores of Europe and Africa, through Western Asia to Northern India and China, and over vast areas of North America likewise,—is composed of an aggregation of larger bodies belonging to the same type; the 'matrix,' or rock-substance, in which these are imbedded, being itself usually made-up (as microscopic examination of their sections demonstrates) of the comminuted particles of similar organisms, and of smaller Foraminifera; although it is sometimes composed (as in the British beds of London Clay which include Nummulites) of accumulations of clayey or other inorganic particles. The structure of the *Nummulite* itself, as elucidated by microscopic examination, presents some extremely remarkable modifications of the ordinary Foraminiferous type. It is composed of a series of chambers, symmetrically disposed in a spiral round a centre, so that a section through its median plane would present very much the appearance of Fig. 209; but each

* The Pyramids of Egypt are built of this material.

whorl invests all the preceding whorls, so as to form a new layer over the entire surface of the disk; and this layer is usually separated from that which it covers, by an intervening space, which is divided into smaller spaces of more or less regular form, by prolongations from the partitions that divide the chambers of the central plane. These prolongations are very differently arranged in different species; thus in some, as *Nummulites distans*, they keep their own separate course, tending towards the centre; whilst in others, as *N. levigata*, they inosculate with each other, so as to divide the space that intervenes between one layer and another into an irregular network. Hence in a vertical section, such as that of which a part is shown in Fig. 337, we see not only the succes-

FIG. 337.

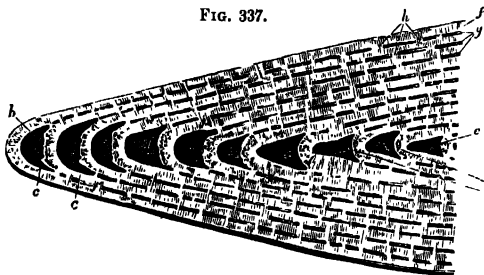

Vertical Section of portion of *Nummulites levigata*:—*a*, margin of external whorl; *b*, one of the outer row of chambers; *c, c*, whorl invested by *a*; *d*, one of the chambers of the fourth whorl from the margin; *e, e'*, marginal portions of the enclosed whorls; *f*, investing portion of outer whorl; *g, g*, spaces left between the investing portions of successive whorls; *h, h*, sections of the partitions dividing these.

sion of chambers along the central plane, each of them having its own roof and floor, and its own lateral partitions dividing it from other chambers of the same whorl, but we also see the superposition of layers over the inner whorls; so that any chamber *d* in a whorl that is surrounded by three others, is shut-in above and below, not only by its own proper shelly covering, but by three additional layers formed by the prolongation of the shelly investments of the external whorls; and in like manner, the innermost of the chambers here represented (that nearest *e*) is enclosed by nine layers above and below, in addition to that by which it is itself covered, these

nine layers being extensions of the covering of the nine whorls that surround it. Notwithstanding that the inner chambers are thus so deeply buried in the mass of investing whorls, yet there is evidence that the segments of sarcode which they contained, were not cut-off from communication with the exterior; but that they may have retained their vitality to the last. The shell itself is almost everywhere minutely porous, being penetrated by parallel tubuli, which pass from one surface to the other like those of dentine. These tubes are shown, as divided lengthways by a vertical section, in Fig. 338 (*a, a*);

FIG. 338.

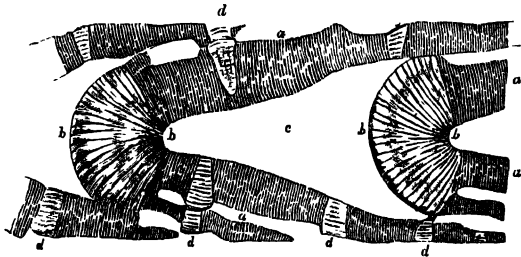

Portion of a thin section of *Nummulites levigata*, taken in the direction of the preceding, highly magnified to show the minute structure of the shell—*a, a*, portions of the ordinary shell-substance traversed by parallel tubuli; *b, b*, portions forming the marginal wall, traversed by diverging and larger tubuli; *c*, one of the chambers laid open; *d, d, d*, pillars of solid substance not perforated by tubuli.

whilst the appearance they present when cut-across in a horizontal section is shown in Fig. 339, the transparent shell-substance *a, a, a* being closely dotted with minute punctations which mark their orifices. In that portion of the shell, however, which forms the margin of each whorl (Fig. 338, *b, b*), the tubes are larger, and diverge from each other at greater intervals; whilst at certain other points, *d, d, d*, the shell-substance is not perforated by tubes, but is peculiarly dense in its texture, forming solid pillars which seem to strengthen the other parts. In Nummulites whose surfaces have been much exposed to attrition, it commonly happens that the pillars of the superficial layer, being harder than the ordinary shell-substance, and being consequently less worn-down, are left as prominences; the presence of which has often been accounted (but erroneously) as a specific character. The

successive chambers of the same whorl communicate with each other by a passage left between the inner edge of the partition that separates them, and the margin of the preceding whorl that forms their inner boundary; this passage is sometimes a single large broad aperture, but is more commonly formed by the more or less complete coalescence of several separate perforations, as is seen in Fig. 337, *b*. Such marked differences in this respect are observable in the several parts of one and the same specimen, that it is obvious that very little account should be taken of differences in the form of aperture, as affording specific or generic distinctions among Foraminifera of this type. But besides the foregoing means of communication, by which the segments of sarcode included in the inner chambers were enabled to continue receiving supplies of nutriment, we meet in Nummulites with a remarkable development of that system of 'interseptal' canals, one of the most characteristic examples of which among recent Foraminifera is presented in *Faujasina*, as already described (§ 291).

FIG. 339.



Portion of Horizontal Section of *Nummulite*, showing the structure of the walls and of the septa of the chambers:—*a, a, a*, portion of the wall covering three chambers, the punctations of which are the orifices of tubuli; *b, b*, septa between these chambers, containing canals which send-out lateral branches, *c, c*, entering the chambers by larger orifices, one of which is seen at *d*.

These canals are frequently found to be filled-up in Nummulites by the fossilizing material; but a careful examination will generally disclose traces of them in the middle of the partitions that divide the chambers (Fig. 339, *b, b*), while from these may be seen to proceed the lateral branches (*c, c*) which, after burrowing (so to speak) in the walls of the chambers,

enter them by large orifices (*d*). As the general distribution of this system of canals in the Nummulite is the same as that shown in *Faujasina* (Fig. 209), and as the canals, although smaller, are far more numerous, it is obvious that through its means the segments of sarcode occupying the chambers

of the most internal walls could send their pseudopodial extensions at once to the exterior.—Of all Foraminifera, the Nummulite is undoubtedly one of the most highly developed types; and its extraordinary multiplication at the earliest part of the Tertiary period, is a very curious feature in the Earth's history. It is commonly considered that this type is now extinct; but the Author, in common with Prof. Williamson, is disposed to question whether there is any essential difference between Nummulites and the existing genus *Nonionina*, which is very abundant in certain localities; since in many species of Nummulites, as in *Nonionina*, the investing layers of the successive whorls are in immediate contact with those that have preceded them, instead of being separated, as in Fig. 337, by spaces prolonged from the cavities of the chambers.

449. The same Nummulitic limestone also contains, in certain localities (as the South-west of France, North-eastern India, &c.) a vast abundance of discoidal bodies termed *Orbitoides*, which are so similar to Nummulites as to have been taken for them, but which, while still Foraminiferous, are formed upon a plan of structure altogether different. On account of the minuteness of their parts, and the completeness of their fossilization, their structure can only be elucidated by sections thin enough to be examined by the microscope with transmitted light; and it is consequently to the assistance afforded by this instrument, that we are indebted for our knowledge of the curious type of organization which it presents.

FIG. 340.

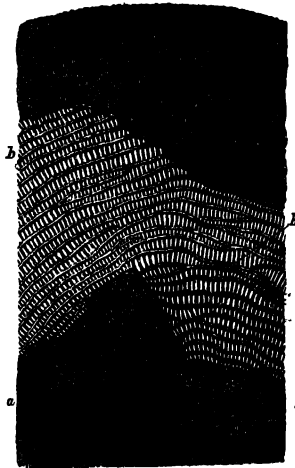

Section of *Orbitoides Prattii*, parallel to the surface; traversing at *a, a*, the superficial layer, and at *b, b*, the median layer.

When one of these disks (which
3 c

vary in size, in different species, from that of a four-penny piece to that of half a crown) is rubbed-down so as to display its internal organization, two different kinds of structure are usually seen in it; one being composed of chambers of very definite form, quadrangular in some species, circular in others, arranged with a general but not constant regularity in concentric circles (Figs. 340, 341, *b, b*); the other, less transparent, being formed of minuter cells which have no such constancy of form, but which might almost be taken for the pieces of a dissected-map (Figs. 340, 341, *a, a*). In the upper and lower

FIG. 341.

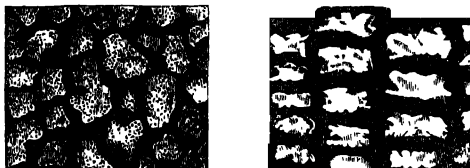

Portions of the same section, more highly magnified;—*a*, superficial layer; *b*, median layer.

walls of these last, minute punctations may be observed, which seem to be the orifices of connecting tubes whereby they are perforated. The relations of these two kinds of structure to each other, are made evident by the examination of a vertical section (Fig. 342); which shows that the portion *a*, Figs. 340,

FIG. 342.

Vertical Section of *Orbitoides Pratii*, showing the large central cell at *a*, and the median layer surrounding it, covered above and below by the superficial layers.

341, forms the central plane, its concentric circles of cells being arranged round a large central cell *a*, as in Orbitolite (Fig. 206); whilst the cells of the portion *b* are irregularly superposed one upon the other, so as to form several layers, which are most numerous towards the centre of the disk, and thin away gradually towards its margin. By the perforations in these layers, the pseudopodia proceeding from the central plane of chambers may have found their way direct to the

surface, or at any rate would have been brought into connection with the segments lying nearer to it.—No organisms precisely resembling the Orbitoides, are known to exist at present; but there are some which differ from it so little, that a knowledge of their structure helps materially to elucidate points, which would otherwise be rendered obscure in it through the changes induced by fossilisation.*

450. The foregoing details, taken in addition to the facts of like nature that have been mentioned in previous parts of this work (as, for example, in § 294), will serve as examples of the essential importance of microscopic investigation, in determining, on the one hand, the real character of various stratified deposits, and, on the other, in elucidating the nature of the organic remains which these may include. The former of these lines of enquiry has not yet attracted the attention which it deserves; since, as is very natural, the greater number of Microscopists are more attracted by those definite forms which they can distinctly recognise, than by the amorphous sediments which present no definite structural characters. Yet it is a question of extreme interest to the Geologist, to determine how far these had their origin in the disintegration of organic structures, and much light may often be thrown upon this question by careful microscopic analysis. Thus the Author having been requested by Mr. Chas. Darwin, about twelve years since, to examine into the composition of the extensive calcareous deposit which covers the surface of the Pampas region of South America, and to compare it with that of the calcareous tufa still in process of formation along the coast of Chili, was able to state that their constituents were in all probability essentially the same, notwithstanding the difference in their mode of aggregation. For the Chilian tufa is obviously composed in great part of fragments of shells, distinguishable by the naked eye; the dense matrix in which these are imbedded is chiefly made-up of minuter fragments, only distinguishable as such by the microscope; while through the midst of these is diffused an aggregation of amorphous particles, that present every appearance of having originated in the yet finer reduction of the same shells, either by attrition or by decomposition. In the Pampas deposit, on the other hand, the principal part was found to be composed of

* See the Author's Memoir on the Microscopic Structure of Nummulite, Orbitolite, and Orbitoides, in the "Quart. Journ. of the Geolog. Society," for Feb. 1850; and the admirable "Description des Animaux Fossiles du Groupe Nummulitique de l'Inde," by MM. D'Archiac and Jules Haime.

amorphous particles, so similar in aspect to those of the Chilian rock that their identity could scarcely be doubted; and scattered at intervals through these were particles of shell, distinctly recognisable by the microscope, though invisible to the naked eye. Thus, although the evidence afforded by the larger fragments of shell was altogether wanting in the Pampas deposit, it could not be doubted that the materials of both were the same, those of the Pampean formation having been subject to greater comminution than those of the Chilian; and this view served to confirm, whilst it was itself confirmed by, the idea thought most probable on other grounds by Mr. Darwin, that the Pampean formation was slowly accumulated at the mouth of the former estuary of the Plata, and in the sea adjoining it.* A similar line of enquiry has been of late systematically pursued by Mr. R. C. Sorby; who has applied himself to the microscopic study of the composition of freshwater marls and limestones, by ascertaining the characters and appearances of the minute particles into which shells resolve themselves by decay, and by estimating the relative proportions of the organic and inorganic ingredients of a rock, by delineating on paper (by means of the camera lucida) the outlines of the particles visible in thin sections, then cutting them out, and weighing the figures of each kind.†

451. It is obvious that, under ordinary circumstances, only the hard parts of the bodies of animals that have been entombed in the depths of the earth, are likely to be preserved; but from these a vast amount of information may be drawn; and the inspection of a microscopic fragment will often reveal, with the utmost certainty, the entire nature of the organism of which it formed part. In the examination of the minuter fossil Corals, and of those Polyzoaries (§ 325) which are commonly ranked with them, the assistance of the microscope is indispensable. Minute fragments of the 'test' or 'spines' of Echinodermata, and of all such Molluscous shells as present distinct appearances of structure (this being especially the case with the Brachiopoda, and with the families of Lamellibranchiate bivalves most nearly allied to them), may be unerringly identified by its means, when the external form of these fragments would give no assistance whatever. In the study of the remarkable ancient group of Trilobites, not

* See Mr. C. Darwin's "Geological Observations on South America," p. 32.

† See "Quart. Journ. of Geolog. Science," 1853, p. 344.

only does a microscopic examination of the casts which have been preserved of the surface of their eyes (Fig. 343), serve to show the entire conformity in the structure of these organs to the 'composite' type which is so remarkable a characteristic of the higher Articulata (§ 383), but it also brings to light certain peculiarities which help to determine the division of the great Crustacean series with which this group has most alliance.* It is in the case of

FIG. 343.

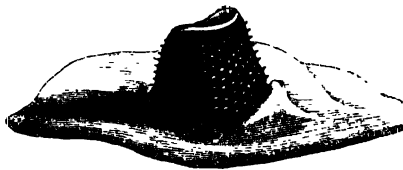
Eye of *Trilobite*.

the Teeth, the Bones, and the Dermal skeleton of Vertebrated animals, however, that the value of Microscopic inquiry becomes most apparent; since the structure of these presents so many characteristics that are subject to well-marked variations in their several classes, orders, and families, that a knowledge of these characters frequently enables the Microscopist to determine the nature of even the most fragmentary specimens, with a positiveness which must appear altogether misplaced to such as have not studied the evidence.

452. It was in regard to *Teeth*, that the possibility of such determinations was first made clear by the laborious researches of Prof. Owen;† and the following may be given as examples of their value.—A rock-formation extends over many parts of Russia, whose mineral characters might justify its being likened either to the *Old* or to the *New Red Sandstone* of this country, and whose position relatively to other strata is such, that there is great difficulty in obtaining evidence from the usual sources, as to its place in the series. Hence the only hope of settling this question (which was one of great practical importance, since, if the formation were *new* red, Coal might be expected to underlie it, whilst if *old* red, no reasonable hope of coal could be entertained) lay in the determination of the Organic remains which this stratum might yield; but unfortunately these were few and fragmentary,

* See Prof. Burmeister "On the Organization of the Trilobites," published by the Ray Society, p. 19.

† See his magnificent "Odontography."

consisting chiefly of teeth which are seldom perfectly preserved. From the gigantic size of these teeth, together with their form, it was at first inferred that they belonged to Saurian Reptiles, in which case the sandstone must have been considered as New Red; but microscopic examination of their intimate structure unmistakably proved them to belong to a genus of Fishes (*Dendrodus*) which is exclusively Palæozoic, and thus decided that the formation must be Old Red.—So again, the microscopic examination of certain fragments of teeth found in a Sandstone of Warwickshire, disclosed a most remarkable type of tooth-structure (shown in Fig. 344), which was also ascertained to exist in certain teeth

FIG. 344.

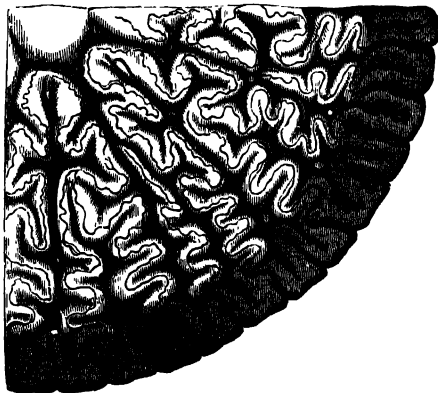
Section of Tooth of *Labyrinthodon*.

that had been discovered in the 'keuper-sandstein' of Wirtemberg; and the identity or close resemblance of the animals to which these teeth belonged having been thus established, it became almost certain that the Warwickshire and Wirtemberg sandstones were equivalent formations, a point of much geological importance. The next question arising out of this discovery, was the nature of the animal (provisionally termed *Labyrinthodon*, a name expressive of the most peculiar feature in its dental structure) to which these teeth belonged.

They had been referred, from external characters merely, to the order of Saurian Reptiles; but these characters were by no means conclusive; and as the nearest approaches to their peculiar internal structure are presented by Fish-Lizards and Lizard-like Fish, it might be reasonably expected that the Labyrinthodon would combine with its reptilian characters an affinity to fish. This has been clearly proved to be the case, by the subsequent discovery of parts of its skeleton in which such characters are very obvious: and by a very beautiful chain of reasoning, Prof. Owen succeeded in establishing a strong probability, that the Labyrinthodon was a gigantic Frog-like animal five or six feet long, with some peculiar affinities to Fishes, and a certain mixture also of Crocodilian characters; and that it made the well-known foot-prints which have been brought to light, after an entombment whose duration can scarcely be conceived (much less estimated), in the Stourton quarries of Cheshire.

453. The more recent researches of Prof. Quekett on the minute structure of *Bone*,* promise to be scarcely less fruitful in valuable results. From the average size and form of the 'lacunæ,' their disposition in regard to each other and to the Haversian canals, and the number and course of the canaliculi, he feels assured that the nature of even a minute fragment of bone may be determined with a considerable approach to certainty; and the following examples, among many which might be cited, appear to justify such assurance.—Dr. Falconer, the distinguished investigator of the fossil remains of the Himalayan region, and the discoverer of the gigantic fossil Tortoise of the Sivalik hills, having met with certain small bones about which he was doubtful, placed them in the hands of Prof. Quekett for minute examination; and was informed, on microscopic evidence, that they might certainly be pronounced Reptilian, and probably belonged to an animal of the tortoise tribe; and this determination was fully borne-out by other evidence, which led Dr. Falconer to conclude that they were toe-bones of his great tortoise.—Some fragments of bone were found, some years since, in a chalk-pit; which were considered by Prof. Owen to have formed part of the wing-bones of a long-winged sea-bird allied to the Albatross. This determination, founded solely on considerations derived from the very imperfectly-preserved external forms of these frag-

* See his Memoir on the 'Comparative Structure of Bone,' in the "Transac. of the Microsc. Society," Ser. 1, vol. ii.; and the "Catalogue of the Histological Museum of the Roy. Coll. of Surgeons," vol. ii.

ments, was called in question by some other palæontologists; who thought it more probable that these bones belonged to a large species of the extinct genus *Pterodactylus*, a flying lizard, whose wing was extended upon a single immensely-prolonged digit. No species of Pterodactyle, however, at all comparable to this in dimensions, was at that time known; and the characters furnished by the configuration of the bones, not being in any degree decisive, the question would have remained unsettled, had not an appeal been made to the Microscopic test. This appeal was so decisive, by showing that the minute structure of the bone in question corresponded exactly with that of Pterodactyle-bone, and differed essentially from that of every known Bird, that no one who placed the least reliance upon that evidence could entertain the slightest doubt on the matter. By Prof. Owen, however, the validity of that evidence was questioned, and the bone was still maintained to be that of a bird; until the question was finally set at rest, and the value of the microscopic test triumphantly confirmed, by the discovery of undoubted Pterodactyle-bones of corresponding and even of greater dimensions, in the same and other chalk quarries.*

* See Prof. Owen's Monograph on the British Fossil Reptiles of the Chalk Formation, p. 80, *et seq.*

CHAPTER XX.

INORGANIC OR MINERAL KINGDOM.—POLARIZATION.

454. ALTHOUGH by far the most numerous and most important applications of the Microscope are those by which the structure and actions of Organized beings are made known to us, yet there are many Mineral substances which constitute both interesting and beautiful objects; being remarkable either for the elegance of their forms, or for the beauty of their colours, or for both combined. The natural forms of inorganic substances, when in any way symmetrical, are so in virtue of that peculiar arrangement of their particles which is termed *crystallization*; and each substance which crystallizes at all, does so after a certain type or plan,—the identity or difference of these types furnishing characters of primary value to the Mineralogist. It does not follow, however, that the form of the crystal shall be constantly the same for each substance; on the contrary, the same plan of crystallization may exhibit itself under a great variety of forms; and the study of these, in such minute crystals as are appropriate subjects for observation by the microscope, is not only a very interesting application of its powers, but is capable of affording some valuable hints to the designer. This is particularly the case with crystals of *Snow*, which belong to the 'hexagonal system,' the basis of every figure being a hexagon of six rays; for these rays "become encrusted with an endless variety of secondary formations of the same kind, some consisting of thin laminæ alone, others of solid but translucent prisms heaped one upon another, and others gorgeously combining laminæ and prisms in the richest profusion;"* the angles by which these figures are bounded, being invariably 60° or 120° . Beautiful arborescent forms are not unfrequently produced, by the peculiar mode of aggregation of individual crystals: of this we have often an example on a large scale on a frosted window; but microscopic crystallizations sometimes present the same

* See Mr. Glaisher's Memoir on 'Snow-Crystals in 1855,' with a number of beautiful figures, in "Quart. Journ. of Microsc. Sci.," vol. iii., p. 179.

curious phenomenon (Fig. 345).—In the following list are enumerated some of the most interesting natural specimens which the Mineral kingdom affords as microscopic objects; these should be viewed by reflected light, under a very low power:—

Antimony, sulphuret	Iron, ilvaite or Elba-ore
Asbestos	— pyrites (sulphuret)
Aventurine	Lapis lazuli
ditto, artificial	Lead, oxide (minium)
Copper, native	— sulphuret (galena)
— arseniate	Silver, crystallized
— malachite-ore	Tin, crystallized
— peacock-ore	— oxide
— pyrites (sulphuret)	— sulphuret
— ruby-ore	Zinc, crystallized

455. The actual process of the *Formation of Crystals* may be watched under the microscope with the greatest facility; all

FIG. 345.



Crystallized Silver.

that is necessary being to lay on a slip of glass, previously warmed, a saturated solution of the salt, and to incline the stage in a slight degree, so that the drop shall be thicker at its lower than at its upper edge. The crystallization will speedily begin at the upper edge, where the proportion of liquid to solid is most speedily reduced by evaporation, and will gradually extend downwards. If it should go on too slowly, or should cease altogether, whilst yet a large proportion of the

liquid remains, the slide may be again warmed, and the part already solidified may be redissolved; after which the process will recommence with increased rapidity.—This interesting spectacle may be watched under any microscope; and the works of Adams and others among the older observers, testify to the great interest which it had for them. It becomes far more striking, however, when the crystals, as they come into being, are made to stand-out bright upon a

dark ground, by the use of the spotted lens, the paraboloid, or any other form of black-ground illumination; still more beautiful is the spectacle when the Polarizing apparatus is employed, so as to invest the crystals with the most gorgeous variety of hues. The following list specifies the salts and other mineral substances, whose crystalline forms are most interesting. When these are viewed with polarized light, some of them exhibit a beautiful variety of colours of their own, whilst others require the interposition of the selenite plate for the development of colour.

Acetate of Copper	Nitrate of Barytes
——— of Manganese	——— of Bismuth
——— of Soda	——— of Copper
——— of Zinc	——— of Potass
Agate (transparent sections)	——— of Soda
Alum	——— of Strontian
Arragonite (transparent sections)	——— of Uranium
Arsenate of Potass	Oxalic acid
Bicarbonate of Potass	Oxalate of Ammonia
Bichromate of Potass	——— of Chromium
Bichloride of Mercury	——— of Lime
Boracic acid	——— of Potass
Borate of Ammonia	——— of Soda
——— of Soda (borax)	Oxalurate of Ammonia
Carbonate of Lime (from urine of horse)	Phosphate of Ammonia
——— of Potass	——— Ammoniaco-Magnesian
——— of Soda	(triple, of urine)
Chlorate of Potass	- of Soda
Chloride of Barium	Prussiate of Potass (red)
——— of Cobalt	ditto ditto (yellow)
——— of Sodium	Salicine
Cholesterine	Sulphate of Ammonia
Chromate of Potass	——— of Cadmium
Citric Acid	——— of Copper
Cyanide of Mercury	——— of Copper, ammoniated
Granite (transparent sections)	——— of Iron
Hypermanganate of Potass	——— of Magnesia
Iodide of Potassium	——— of Potassa
——— of Quinine	——— of Soda
Mannite	——— of Zinc
Murexide	Tartaric Acid
Muriate of Ammonia	Uric Acid
Nitrate of Ammonia	Urate of Ammonia
	——— of Soda

456. It not unfrequently happens that a remarkably beautiful specimen of crystallization develops itself, which the observer desires to keep for display. In order to do this successfully, it is necessary to exclude the air; and Mr. Warrington recommends castor-oil as the best preservative. A small quantity of this should be poured on the crystallized surface, a gentle warmth applied, and a thin-glass cover then laid upon the drop, and gradually pressed-down; and after the superfluous

oil has been removed from the margin, a coat of marine-glue or other varnish is to be applied.

457. Although most of the objects furnished by Vegetable and Animal structures, which are advantageously shown by Polarized light, have been already noticed in their appropriate places, it will be useful here to recapitulate the principal, with some additions.

Vegetable.

Cuticles, Hairs, and Scales, from
Leaves (§§ 220, 246)
Fibres of Cotton and Flax.
Raphides (§ 230)
Spiral cells and vessels (§§ 228, 232)
Starch-grains (§ 229)
Wood, longitudinal sections of,
mounted in balsam (§ 239)

Animal.

Fibres and Spicules of Sponges

Polypidoms of Hydrozoa (§ 305)
Polyzoaries (§ 330)
Spicules of Gorgoniæ (§ 309)
Tongues (Palates) of Gasteropods
(§ 347)
Scales of Fishes (§§ 408, 409)
Sections of Hairs (§ 411)
———— of Quills (§ 412)
———— of Horns (§ 413)
———— of Shells (§ 336)
———— of Skin (§ 418)
———— of Teeth (§§ 406, 407)
———— of Tendon, longitudinal.

ADDITIONS AND CORRECTIONS.

Page 89, *note*.—Since the earlier part of this volume passed through the press, Messrs. Smith and Beck have brought-out the “Educational Microscope” there alluded-to; and after a careful examination of it, the Author can strongly recommend it as admirably adapted to the purposes for which it is intended. It is fitted with two eyepieces and two objectives, giving a range of powers from 55 to 350 diameters; and may also be furnished with an extra-low power for large opaque objects, at a small additional cost. For the additional sum of £5, a Lieberkuhn, Parabolic Illuminator, Polarizing Apparatus, Camera Lucida prism, Aquatic box, and Zoophyte-Trough are supplied; all fitted into the same very portable case, and rendering the instrument extremely complete.

Page 252.—Having had occasion, during the last few months, to mount a large number of objects in shallow cells, the Author has adopted the recommendation of a friend, to make use of cells which are sunk by grinding-out a concave in the thickness of a glass plate. These, until recently, were costly; but they are now made in large quantities, and their price has been so much reduced, that they can be obtained more cheaply than any other kind. For objects whose shape adapts them to the form and depth of the concavity, these cells will be found peculiarly advantageous; since they do not hold air-bubbles so tenaciously as do those with perpendicular walls; and there is no cemented plate or ring to be loosened from its attachment, either by a sudden jar or by the lapse of time. For transparent objects, however, they are less suitable (unless manufactured with more care than is usually given to them) than they are for opaque; since the concave bottom is seldom so highly polished, as to be free from scratches and roughnesses, which greatly interfere with the appearance of the picture.—Cells of this kind may be obtained, from Messrs. Jackson, No. 315, Oxford-street, either of round or oval form, and not only ground-out of slides of the

usual size (3 in. by 1) and thickness, but also hollowed in pieces of plate-glass of larger dimensions.

The Author would also modify the remarks which he made in p. 228, respecting the best method of employing gold-size so as to prevent its 'running-in.' For he has found it preferable to employ *very liquid* Gold-size, but to use it in extremely small quantity in the first instance; since whenever the glass-cover lies perfectly flat on its bed, and the fluid beneath extends to the edges, the thin layer of this varnish dries very quickly, without any tendency to run-in. When this has completely set, a second layer should be applied; and a layer of Asphalte over the whole will add to its security, and improve the appearance of the mounting. The danger of running-in appears to the Author to be the greatest, when, in consequence of the use of old and viscid gold-size, the layer is too thick, and is long in drying. His experience leads him to distrust Asphalte when used alone, as being liable to admit air after a lengthened period of drying.—He has recently learned from Mr. Tomes, that he finds saturated solution of arsenious acid to be a very good medium for mounting delicate preparations of animal structures.

Page 468. It appears probable, from the recent observations of Mr. Weston (Quart. Journ. of Microsc. Science, Jan., 1856,) and others, that the supposed 'conjugation' of *Actinophrys* is a mere fusion of two bodies which may separate again unchanged, and is not a generative phenomenon. The same would appear to be true of it in this respect, as of *Gregarina* (p. 620).

Page 538, line 14 from bottom.—For *Tubularidæ* read *Sertularidæ*.

INDEX.

- Aberration, chromatic, 47—50.
 ————— spherical, 45—47.
- Acalephs*, see *Medusæ*.
- Acarida*, 682, 683.
- Achyla prolifera*, 350, 351.
- Acineta*-form of *Vorticella*, 481—483.
- Achnanthes*, 327.
- Achromatic Condenser, 124—127, 130;
 use of, 174—176.
- Achromatic correction, 10; principle
 of, 49, 50; application of, 50—52.
- Actiniform Zoophytes*, 549—552.
- Actinocyclus*, 316, 317.
- Actinophrys*, 466—469.
- Adipose tissue, 715, 716.
- Adjustment, of Focus, 66, 67; uses
 of, 162—165.
 ————— of Object-glass, for thick-
 ness of cover, 52—54; mode of
 making, 166—169.
- Agates, sponge-remains in, 747.
- Air-bubbles, microscopic appearances
 of, 189.
- Alcyonian Zoophytes*, 547—549.
- Alcyonidium*, 577, 578.
- ALGÆ, higher, microscopic structure
 of, 366—373 (see *Protophyta*).
- Amarocucum*, structure of, 582—584.
- Amici's Prism for oblique illumina-
 tion, 131.
- Amœba*, 464—466.
- Anacharis alsinastrum*, rotation in,
 413, 414.
- Anagallis*, petal of, spiral vessels in,
 463.
- Angular aperture of object-glasses,
 47, 51—53; real value of, 194—
 198.
- Animalcule-Cage, 145, 170.
- ANIMALCULES, early researches on,
 7; Ehrenberg's observations on,
 18—20, 472—488; Dujardin's re-
 searches on, 19; see *Infusoria*, *Rhi-
 zopoda*, and *Rotifera*.
- Animals, distinction of from Plants,
 263, 264, 469, 470.
- ANNELIDA, 625; marine, circulation
 in, 625—627; metamorphoses of,
 627, 628; luminosity of, 628; fresh-
 water, 628, 629.
- Annular Condenser, Shadbolt's, 133,
 134.
- ANNULOSA, 618; see *Entozoa*, *Turbel-
 laria*, and *Annelida*.
- Anomia*, structure of shell of, 597.
- Antennæ of Insects, 660—662.
- Anthers, structure of, 453—455.
- Antheridia of Cryptogamia, discovery
 of, 15, 16; see *Antherozoids*.
- Antherozoids, of *Vaucheria*, 349; of
Sphaeroplea, 354; of *Characeæ*, 362
 —364; of *Fucl*, 369; of *Floridææ*,
 371; of *Marchantia*, 391; of *Mosses*,
 393; of *Ferns*, 402, 403.
- Aphides*, non-sexual reproduction of,
 681, 682.
- Anthozoa*, 528, 547—552.
- Apple*, cuticle of, 444, 445.
- Apus*, 636.
- Aquatic Box, 145, 170.
- ARACHNIDA, microscopic forms of,
 682, 683; eyes of, 683; respiratory
 organs of, 683, 684; feet of, 684;
 spinning apparatus of, 684, 685.
- Arachnoidiscus*, 317, 318.
- Archegonia, of *Marchantia*, 397, 391;
 of *Mosses*, 394; of *Ferns*, 403—405.
- Arcolar tissue, 710.
- Argulus*, 640, 641.
- Artemia*, 637.
- Ascaris*, 620, 621.
- Asci of Lichens, 374; of Fungi, 376.
- Ascidians*, compound, 21, 582; social,
 585—587.
- Asphalte, use of, 228.
- Aspidium*, fructification of, 399—401.
- Aspidisca*-form of *Trichoda*, 485.
- Asteriada*, skeleton of, 559, 560; me-
 tamorphoses of, 565—567.
- Asteroida*, 547—549.
- Auditory vesicles of Mollusks, 616,
 617; development of, 613.
- Avicularia of Polyzoa, 579, 580.
- Azure-blue* butterfly, scales of, 202,
 652.
- Bacillaria paradoxa*, 326; movements
 of, 313, 314.
- Bailey, Prof., his diatomaceous tests,
 206.

- Balani*, metamorphoses of, 641—643.
 Bark, structure of, 438, 439.
Barnacles, metamorphoses of, 641—643.
Bat, hair of, 202, 699, 700.
 Battledoor scale of *Polyommatus*, 202—203.
Batrachospermea, 358, 359.
Bee, eyes of, 667; proboscis of, 664, 665; wings of, 674; sting of, 679.
 Berg-mehl, 335, 336.
Beros, 545, 546.
Biddulphia, 329; markings on, 305; self-division of, 309.
 Binocular Microscopes, 104—107.
 Bird, Dr. Golding, on preparation of Zoophytes, 540.
 Birds, bone of, 689; feathers of, 702, 703; blood of, 704—706; lungs of, 736, 737.
 Bird's-head processes of *Polyzoa*, 579, 580.
 Black-Japan varnish, 229.
 Black-Ground Illuminators, 132—135, 177, 178.
Blenny, viviparous, scales of, 695.
 Blood-Disks of *Vertebrata*, 187, 704—707; mode of examining and preserving, 707, 708; circulation of, mode of examining, 726—729.
 Blood-Vessels, injected preparations of, 730—734; disposition of, in different parts, 734—738.
 Bone, structure of, 188, 687—690; mode of making sections of, 215—220, 690.
 Bones, Fossil, examination of, 216, 759.
Botrytis bassiana, 377.
Botryllans, 584.
Bowerbankia, 21, 576, 577, 581.
Brachionus, 491, 494, 500.
Brachiopoda, structure of shell of, 598—600.
Branchiopoda, 633, 635—637.
Branchipus, 637.
 Brooke, Mr., his Object-glass holder, 118, 119.
 Brunswick-black, use of, 228.
Buccinum, tongue of, 608; egg-capsules of, 609; development of, 611.
Bugs and their allies, 648; wings of, 676.
Bugula avicularia, 579, 580.
 Bull's-Eye Condenser, 139; use of, 182.
 Busk, Mr. G., on *Volvox*, 279, 284.
 Butterflies, see *Lepidoptera*.
- Cabinets for microscopic objects, 258.
Cactus, raphides of, 422.
Calycanthus, stem of, 439.
 Camera Lucida, 116, 117; use of in Micrometry, 118.
Campanularidæ, 536—538.
Campylodiscus, 536.
 Canada balsam, use of as cement, 217, 218, 229, 230; mounting of objects in, 236—244.
 Canal-system of *Foraminifera*, 515—517.
 Canaliculi of bone, 688—690.
 Capillaries, circulation in, 726—729; injection of, 730—733; distribution of, 734—738.
Carp, scales of, 696.
 Cartilage, structure of, 716—718.
 Cells for mounting objects, of cement, 249; of thin glass, 250; of plate-glass, 251; shallow, 251; deep and built-up, 252—255; mounting objects in, 255—257.
 Cells, Animal, nature of, 463, 464.
 —Vegetable, 12; nature of, 265, 266; rotation in, 412—417; thickening deposits in, 417, 418; spiral deposits in, 419; starch-grains in, 420, 421; raphides in, 422.
 Cellular Tissue, ordinary form of, 408—410; stellate, 411; cubical, 411; dimensions of, 411, 412; component cells of, 412.
 Cement-Cells, mode of making, 249.
 Cementum of Teeth, 693, 694.
 CEPHALOPODS, shell of, 602, 603; chromatophores of, 617.
Ceramiacea, 371.
Chatophoracea, 357, 358.
 Chalk, *Foraminifera*, &c., of, 746—748.
Characea, 359, 360; rotation of fluid in, 17, 361; multiplication of, by zoospores, 362; sexual apparatus of, 362—364.
 Cherry-stone, cells of, 418.
 Chemical Re-agents, use of in Microscopic research, 220—223.
Chilodon, teeth of, 476; self-division of, 480.
Chirodota, calcareous skeleton of, 564.
 Chloride of Calcium, as mounting medium, 246.
 Choroid, pigment of, 712.
 Chromatic Aberration, 47, 48; means of reducing and correcting, 49, 50.
 Chromatophores of *Cephalopods*, 616.
Cidaris, spines of, 558.
 Ciliary action, nature of, 488, 489; on gills of *Mollusks*, 615.
 Ciliated epithelium, 714, 715.
 Circulation of Blood in *Vertebrata*, 726—729; in *Insects*, 667, 668; alternating, in *Tunicata*, 586, 587.

- Cirrhipeda*, metamorphoses of, 641—643.
- Clavellinidæ*, 595.
- Clarke, Mr. J. L., his mode of preparing sections of Spinal Cord, 726.
- Cleanliness, importance of, to Microscope, 158—160; in mounting objects, 257.
- Closterium*, movement of fluid in, 287—289; duplicative subdivision of, 289, 290; multiplication of, by gonidia, 295; conjugation of, 296.
- Clypeaster*, spines of, 558.
- Coal, nature of, 741—743.
- Coarse-adjustment, 66—68; uses of, 162—164.
- Cockchafer*, cellular integument of, 650; eyes of, 658; antenna of, 661; spiracle of larva of, 671.
- Cockle of wheat, 621, 622.
- Coddington lens, 58.
- Cohn, Dr., his account of various states of Protococcus, 270—277; his researches on Infusoria, 488 note; on reproduction of Rotifera, 496, 497.
- Coleoptera*, mouth of, 662—664.
- Collection of objects, general directions for, 259—261.
- Collomia*, spiral fibres of, 419, 420.
- Columella of Mosses, 397.
- Comatula*, metamorphosis of, 570.
- Compound Microscope, principle of, 59—65; various forms of, 79—107.
- Compressorium, 148—150; use of, 170.
- Concave lenses, refraction by, 43.
- Conceptacles of Marchantia, 389, 390.
- Condenser, Achromatic, 124—127, 130; use of, 174—176.
- Annular, 133.
- for Opaque Objects, ordinary, 140; bull's-eye, 140; mode of using, 180—183.
- Confervaceæ*, 352; self-division of, 353; zoospores of, 354; sexual reproduction of, 354, 355.
- Conifera*, peculiar woody fibre of, 423; absence of ducts in, 427, 436; fossil, 436, 741—743.
- Conjugation, of Palmoglaæ, 269; of Desmidiaceæ, 296—299; of Diatomaceæ, 310—312; of Conjugatæ, 355, 356; (supposed) of Actinophrys, 468, 765.
- Contractile vesicle of Volvox, 279; of Amœba, 465; of Actinophrys, 467; of Infusoria, 479, 480.
- Convex lenses, refraction by, 39—43; formation of images by, 44.
- Coquilla nut, cells of, 416.
- Coral, red, 549; stony, 549, 550.
- Corallines* (zöophytic), 7, 20; true, 371, 372.
- Cordylophora*, 533, 534.
- Cork, 438.
- Corpuscles of Blood, 704—707.
- Corti, Abbé, on rotation in Chara, 17.
- Corynidæ*, 533—535.
- Coscinodiscus*, 316, 316.
- Cosmarium*, self-division of, 290; conjugation of, 296.
- Crab*, shell-structure of, 643, 644; metamorphoses of, 644—646.
- Cricket*, gastric teeth of, 667; sounds produced by, 675.
- Crinoidea*, skeleton of, 560.
- Crusta petrosa of Teeth, 693, 694.
- CRUSTACEA, 630; lower forms of, 630—632; entomostracous, 633—639; suctorial, 640, 641; cirrhiped, 641—643; decapod, shell of, 643, 644; metamorphoses of, 644—646.
- CRYPTOGAMIA, microscopic study of, 13—16; movements of, 14; sexuality of, 15, 16, 407 (see Protophyta, Alga, Mosses, &c.).
- Crystals of snow, 761.
- Crystallization, Microscopic, 762.
- Ctenoid scales of Fish, 698.
- Curculionidæ*, 651, 655.
- Cuticle of Equisetaceæ, 405; of Flowering Plants, 443—447.
- Cuttle-fish*, shell of, 602, 603.
- Cycloid scales of Fish, 696.
- Cyclops*, 634, 635; fertility of, 638.
- Cydippe*, 545, 546.
- Cypræ*, 633, 634.
- Cypræa*, structure of shell of, 601.
- Cystic Entozoa*, 619.
- Cysticercus*, 619.
- Cythere*, 634.
- Dalrymple, Mr., on Notommata, 494.
- Dalyell, Sir J. G., on development of Medusæ, 542—544.
- Daphnia*, 636; ephippial eggs of, 638, 639.
- Darwin, Mr., on Pampean formation, 755, 756.
- Deane's Gelatine, 245—247.
- Decapod Crustaceæ*, shell of, 643, 644; metamorphoses of, 644—646.
- Defining power of object-glasses, 192, 193.
- Demodex folliculorum*, 683.
- Dentine of Teeth, 691—693.
- Dendrodus*, teeth of, 758.
- Dermestes*, hair of, 202, 654.
- Desmidiaceæ*, general structure of, 285—287; movement of fluid in, 287—289; duplicative subdivision of, 289—291; formation of gonidia by, 291—294; origination and mul-

- tiplication of varieties in, 294—296; conjugation of, 296—299; collection of, 299, 300.
- Deutzia*, stellate hairs of, 448, 447.
- Development, Von Baer's law of, 23.
- Animal, application of Microscope to, 21—29.
- Vegetable, application of Microscope to, 12—18.
- Diamond-beetle*, 651, 655; foot of, 676.
- Diaphragm-Plate, 123, 124.
- Diatoma*, 328.
- Diatomaceæ*, vegetable nature of, 300; cohesion of frustules of, 301, 302; siliceous envelope of, 302—304; markings of, 304—307; self-division of, 308—310; gonidia of, 310; conjugation of, 310—312; limits of species of, 312, 313, 332; movements of, 313, 314; classification of, 314—332; general habits of, 332—335; fossilized deposits of, 335, 336, 743—747; collection of, 336—339; mounting of, 338—340; their value as tests, 202—206.
- Dicotyledonous Stems, structure of, 431—441.
- Dictyochalix*, 524.
- Didymoprium*, self-division of, 289; conjugation of, 297, 298.
- Diffraction of Light, errors arising from, 185—187.
- Dipping-Tubes, 150.
- Dissecting Microscope, Quekett's, 77—79.
- Smith and Beck's, 89—91.
- Dissection, microscopic, 208—210.
- Diatoma*, 622, 623.
- Dog*, foot of, epidermis of, 713.
- Doris*, spicular skeleton of, 602.
- Dotted Ducts, 426.
- Doublet, microscopic, 67.
- Draw-Tube, 108, 109.
- Dry-mounting of objects, 232—236.
- Ducts, of Plants, 425—427.
- Dujardin, M., on Rotifera, 498, 501.
- Duplicative subdivision, of Palmoglaea, 269; of Protooccus, 273; of Desmidiaceæ, 289—291; of Diatomaceæ, 308—310; of Confervaceæ, 353, 354; of Protozoa, 466—468; of Infusoria, 480.
- Dusidea*, skeleton of, 526.
- Dytiscus*, foot of, 677, 678.
- * *Eagle-Ray*, teeth of, 692.
- Echinida*, shell of, 553, 554; ambulacral disks of, 555; spines of, 555—557; pedicellariæ of, 558, 559; teeth of, 559; metamorphosis of, 567—570.
- ECHINODERMATA, skeleton of, 553—565; metamorphoses of, 565—570.
- Educational Microscopes, 76, 80, 765.
- Educational Value of Microscope, 30—37.
- Eel*, scales of, 695, 696.
- Eels*, of Paste and Vinegar, 621.
- Eggs of Insects, 680, 681.
- Egg-shell, fibrous structure of, 708.
- Ehrenberg, Prof., his researches on Animalcules, 18—20, 472—488, 492—501; on Polycystina, 519—522.
- Elaters of Marchantia, 391.
- Elementary Tissues; see Tissues.
- Elytra, of Beetles, 675.
- Embryo, vegetable, development of, 458.
- Enamel of Teeth, 693, 694.
- Encrinetes*, 580.
- Encysting process of Infusoria, 481—485.
- Endochrome of vegetable cell, 265.
- Enterobryus*, 379—382.
- Entomostracous Crustacea*, 633; their classification, 633—637; reproduction of, 637—640.
- Entozoa*, 618; simplest form of, 619, 620; cystic, 619; nematoid, 620—622; trematode, 622, 623.
- Ephemera*, larva of, 649, 667, 672.
- Epidermis of Animals, structure of, 711—713.
- of Plants, nature of, 447.
- Epithelium, 713, 714; ciliated, 714, 715.
- Equisetaceæ*, 405; cuticle of, 405; spores of, 406.
- Erector, 109, 110.
- Euryale*, skeleton of, 559, 560.
- Eyes, care of, 158.
- Eyes, of Mollusks, 615, 616; of Insects, 657—660.
- Eye-piece, 61; Huyghenian, 62, 63; Ramsden's, 63, 64; Achromatic, 64; Meniscus, 64, 65; Micrometric, 112—115.
- Fallacies of Microscopists, 8—10, 184—191.
- Falconer, Dr., on bones of fossil Tor-toise, 759.
- Fat-cells, 715, 716; capillaries of, 734, 735.
- Faujasina*, 506; canal-system of, 515—517.
- Feathers, structure of, 702, 703.
- Feet of Insects, 676—678.
- FERNS, 398, 399; fructification of, 399—401; spores of, 401, 402; prothallium of, 402; antheridia of, 402, 403; archegonia of, 403, 404; generation and development of, 404, 405.

- Fertilization of ovule, in flowering-plants, 457—460.
- Fibre-cells of anthers, 454, 455.
- Fibres, Muscular, 719—723.
— Nervous, 723—726.
- Fibrillæ of Muscle, structure of, 721, 722.
- Fibrous tissues, 708—710.
- Field's Compound Microscope, 80—82.
— Simple Microscope, 75—77.
- Filiferous capsules of Zoophytes, 550—552.
- Finder, 121—123.
- Fine Adjustment, 66, 67; uses of, 164, 165.
- FISHES, bone of, 690; teeth of, 691; scales of, 694—698; blood of, 704—706; circulation in, 729; gills of, 735.
- Fishing-Tubes, 150.
- Flatness of field of object-glasses, 195.
- Flint, organic structure in, 747; examination of, 748.
- Floridæ*, 371.
- Floscularians*, 498, 499.
- Flowers, small, as microscopic objects, 451, 452.
- Fluid, mounting objects in, 247—257.
- Fluke*, 622, 623.
- Flustra*, 20, 572—578.
- Fly*, number of objects furnished by, 647; tongue of, 663, 664; spiracle of, 671; wing of, 674; foot of, 676, 677.
- Focal Adjustment, 66, 67; precautions in making, 162—165; errors arising from imperfection of, 187, 188.
- Foraminifera*, 19, 502; their relation to Rhizopoda, 503; their general structure, 503—507; peculiar forms of, 507—514; relation of, to Sponges, 514; canal-system of, 515—517; collection and mounting of, 517—519; fossil deposits of, 743—749.
- Forceps, 151; stage, 143.
- Fossil Bone, 759, 760.
— Diatomacæ, 335, 336, 743—747.
— Foraminifera, 743—755.
— Polycystina, 521, 522.
— Sponges, 747.
— Teeth, 757—759.
— Wood, 443, 740—743.
- Fowl*, lung of, 737.
- Frog*, blood of, 705, 706; circulation in web of, 726—728; in tongue of, 728, 729; lung of, 736.
- Fucacæ*, 366, 367; sexual apparatus of, 367—370; development of, 370.
- Fungi*, simplest forms of, 374—376; in bodies of living animals, 376—382; in substance, or on surface of plants, 382—385; higher forms of, 386, 387.
- Fusulina*, 749.
- Furze, Mr., his arrangement for illumination, 138.
- Gad-flies*, ovipositor of, 680.
- Gastrellonella*, 330.
- Gairdner's Simple Microscope, 73—75.
- Gall-flies*, ovipositor of, 679.
- Ganoid scales of Fish, 697.
- GASTEROPODA, structure of shell of, 601, 602; tongues of, 603—608; development of, 608—614; organs of sense of, 615—617.
- Gastric teeth of Mollusks, 608; of Insects, 667.
- Gelatine, Deane's, 245—247.
- Gelatinous nerve-fibres, 724, 725.
- Geology, applications of Microscope to, 740.
- Geranium*-petal, peculiar cells of, 452.
- Gills, of Mollusks, ciliary motion on, 615; of Fishes, distribution of vessels in, 735; of Water-newt, circulation in, 729; ciliary movement in, 735.
- Gillett's Condenser, 125.
- Glands, structure of, 718, 719.
- Glass Slides, 224.
— Thin, 220—227.
- Glue, liquid, use of, 228.
— marine, use of, 230—232.
- Glycerine, use of, in mounting objects, 245.
- Gnats*, larvæ of, 667, 668.
- Goadby's Solution, 246.
- Gold-size, use of, 228, 766.
- Goniometer, 115.
- Gomphonema*, 323, 324.
- Gonidia, multiplication by, in Desmidiacæ, 291—294; in Diatomacæ, 310; in Hydrodictyon, 352; in Chara, 362; in Floridæ, 371; in Lichens, 373.
- Gorgonia*, spicules of, 549.
- Gosse, Mr., on Melicerta, 499; on thread-cells of Zoophytes, 550—552.
- Grammatophora*, 329; its use as test, 206.
- Grantia*, structure of, 523—527.
- Grasses, silicified cuticle of, 446, 447.
- Gregarina*, 619, 620.
- Grinding and Polishing of Sections, 215—220.
- Gromia*, 503, 504.
- Growing-Slide, 144.
- Grubb's Prism for oblique illumination, 131.
- Guano, Diatomacæ of, 337, 338.

- Hairs, of Mammals, 188; structure of, 698—701; mode of mounting, 702; of Insects, 654—656.
- Hairs, of Vegetable cuticles, 446; rotation of fluid in, 415, 416.
- Halkiondria*, spicules of, 525.
- Harvest-bug*, 683.
- Haversian Canals of bone, 687.
- Heliopelta*, 317, 318.
- Haustellate Mouth, 665, 666.
- Henfrey, Mr., on development of pollen-grains, 454.
- Hepatica*, 387; see *Marchantia*.
- Herapathite, 135.
- Hepworth, Mr., on feet of Insects, 677.
- Highley's Hospital Microscope, 82—84.
- Hippocrepian Polyzoa*, 573, 581.
- Histology, 26.
- Hæmatococcus*, its relations to *Protococcus*, 271.
- *sanguineus*, 341.
- Hogg, Mr., on development of *Lymnæus*, 611.
- Holland, Mr., his triplet, 57.
- Holothurida*, skeletons of, 563—565.
- Hoofs, structure of, 703.
- Hooker, Dr. Jns., on Antarctic Diatomaceæ, 333, 334.
- Horns, structure of, 703, 704.
- Huxley, Mr., on Rotifera, 495, 496, 501; on *Noctiluca*, 547; on blood of Annelida, 627.
- Huyghenian eye-piece, 61—63.
- Hydatina*, 500; reproduction of, 496.
- Hydra*, discovery of, 6; structure of, 528—532.
- Hydrodictyon*, 351, 352.
- Hydrozoa*, 532—544.
- Hymenoptera*, proboscis of, 664, 665; wings of, 674; stings and ovipositors of, 678—680.
- Jackson, Mr., his eyepiece micrometer, 113, 114.
- Jelly-fish*, development of, 541—544.
- Ice-plant*, cuticle of, 445, 446.
- Ichneumonidæ*, ovipositor of, 679.
- Illumination of opaque objects, 180—184; of transparent objects, 174—178.
- Illuminators, Black-ground, 132—135, 177, 178.
- Oblique, 129—132, 176, 177.
- White-Cloud, 128, 176.
- Images, formation of, by convex lenses, 44.
- Indicator, 115.
- Indusium of Ferns, 399—401.
- Inflection of Light, errors arising from, 185, 186.
- Infundibulate Polyzoa, 578—581.
- Infusorial Earths, 335—338, 743.
- INFUSORIA, 19, 472, 473; structure of, 474—479; movements of, 476, 477; reproduction of, 480—486; peculiar forms of, 486—488.
- Injections of blood-vessels, mode of making, 730—733; mode of mounting, 733, 734.
- Inorganic substances as objects, 762.
- INSECTS, great number of objects furnished by, 647, 648; microscopic forms of, 649, 649; antennæ of, 660—662; circulation of blood in, 667, 668; eggs of, 680—682; eyes of, 657—660; feet of, 676—678; gastric teeth of, 667; hairs of, 654—656; integument of, 649, 650; mouth of, 662—666; ovipositors of, 678—680; scales of, 650—656; spiracles of, 671—673; stings of, 678, 679; tracheæ of, 668—673; wings of, 673—676.
- Iris*, structure of leaf of, 449, 450.
- Isthmia*, 329; markings on, 304—306; self-division of, 309.
- Itch-Acarus*, 682.
- Integument of Insects, structure of, 649, 650.
- Kidneys, structure of, 719.
- Labelling of objects, 257, 258.
- Labyrinthodon*, tooth of, 758.
- Lacunæ of bone, 688—690.
- Laguncula*, 572—575, 581.
- Lamps, microscope, 154—156.
- Lealand, Mr., his preparations of muscular fibre, 202, 723.
- Leaves, structure of, 449—451; mode of examining, 451.
- Leech*, 629; teeth of, 629.
- Legg, Mr., on collection of Foraminifera, 517, 518.
- Lepidoptera*, scales of, 650—656; proboscis of, 665, 666; wings of, 674, 675; eggs of, 660.
- Lepidosteus*, bony scales of, 688, 690, 697.
- Lepisma*, scales of, 654.
- Lepræna*, 572, 578.
- Lever of Contact, 226.
- Levant-Mud, microscopic organisms of, 744—747.
- Lever Stage, 120.
- Lichens*, 373, 374.
- Licmophora*, 324, 325.
- Lieberkühn, speculum of, 142; mode of using, 183, 184.

- Light, suitable for Microscope, 154—156; position of, 157; arrangement of, for transparent objects, 171—178; for opaque objects, 180—184.
- Liquid Glue, use of, 228.
- Lister, Mr., his improvements in Achromatic lenses, 51, 52.
- Liver, structure of, 718.
- Lungs, of Reptiles, 736; of Birds, 736, 737; of Mammals, 738.
- Lymnaeus*, development of, 608—610.
- Magnetic Stage, 123.
- Magnifying power, mode of determining, 206, 207; augmentation of, 161; of different objectives, 199—203.
- Mahogany*, section of, 437.
- MAMMALS, bone of, 689; teeth of, 692—694; hairs, &c., of, 698—704; blood of, 704—708; lungs of, 737.
- Man*, hair of, 700, 701.
- Mandibulate mouth of Insects, 662—664.
- Marchantia*, general structure of, 397, 398; stomata of, 398, 399; conceptacles of, 389, 390; sexual apparatus of, 391, 392.
- Margaritaceae*, shells of, 589, 592, 594.
- Marine-Glue, uses of, 230—232.
- Mastogloia*, 331, 332.
- Medullary Rays, 434—437.
- Medusa*, development of, from Zoo-phytes, 23, 24, 540—544.
- Megatherium*, teeth of, 694.
- Melicertians*, 498, 499.
- Meloseira*, 329, 330; self-division of, 310; conjugation of, 312.
- Menelaus*, scale of, 652.
- Meniscus eye-piece, 64, 65.
- Meridion*, 325, 326.
- Metamorphoses of Animals, 21; of Cirrhipeds, 21, 641—643; of Crustacea, 22, 644—646; of Echinoderms, 22, 665—670; of Infusoria, 481—485; of Mollusks, 22, 587, 588; of Annelids, 23, 627, 628.
- Micrometer, Cobweb, 111, 112; eye-piece, 112—115.
- Micrometry, by Micrometer, 110—115; by Camera Lucida, 118.
- MICROSCOPES, early history of, 4—10; later history of, 10—29; educational uses of, 30—37.
- optical principles of construction of, 54—65; mechanical principles of construction of, 66—70.
- Compound*, 59—65, 79, 80.
- Field's, 80—82.
- MICROSCOPES, Highley's, 82—84.
- Nacht's, 84—87.
- Ditto, binocular, 104—107.
- Powell and Lealand's, 99—101.
- Ross's, 95—99.
- Smith and Beck's large, 101—103.
- Ditto dissecting, 89—91.
- Ditto student's, 87, 88.
- Ditto educational, 765.
- Warington's universal, 91—95.
- *Simple*, 54—59, 70, 71.
- Field's, 75—77.
- Gairdner's, 73—75.
- Quekett's, 77—79.
- Ross's, 71—73.
- support required for, 154; care of, 158—160; general arrangement of, 160; for transparent objects, 169—174; for opaque objects, 178—180.
- Microscopic Dissections, 208—210.
- Microscopists, fallacies of, 8—10.
- Microtome, 211.
- Mildew*, fungous vegetation of, 382—384.
- Millon's test for albuminous substances, 223.
- Mineral Objects, 761—763.
- Minnow*, circulation in, 729.
- Molecular movement, 190, 191.
- MOLLUSCA, shells of, 589—603; tongues of, 603—608; development of, 608—614; ciliary motion on gills of, 615; organs of sense of, 615—617.
- Monocotyledonous Stems, structure of, 428—430.
- Morpho menelaus*, scale of, 201, 652.
- Mosses, structure of, 392, 393; sexual apparatus of, 393—396; urns of, 396, 397; peristome of, 397; development of spores of, 398.
- Moths*; see Lepidoptera.
- Mould*, fungous vegetation of, 382, 383.
- Mounting of objects; see Objects.
- Mounting-Plate, 230.
- Mouse*, Ear of, cartilage of, 716.
- Mouth of Insects, 662—666.
- Mucous Membranes, structure of, 711; capillaries of, 734, 735.
- Müller, O. F., his researches on Animalcules, 7.
- Müller, Prof., his researches on Echinoderm-larvæ, 565—570.
- Muscardine, or silk-worm disease, 14, 15, 377.

- Muscular-fibre, structure of, 719—722;**
value of as test-object, 202; mode
of examining and preparing, 722,
723; capillaries of, 734, 735.
- Musk-deer, hair of, 699.**
- Mussel, ciliary action on gills of, 615.**
- Mya, structure of hinge-tooth of, 593.**
- Mycelium of Fungi, 383, 387.**
- Myliobates, teeth of, 692.**
- Nachet's Microscope, 84—87; his
Binocular Microscope, 104—107;
his Prism for oblique illumination,
130, 131.**
- Nacre, structure of, 594—596.**
- Nais, 628, 629.**
- Nassula, teeth of, 476.**
- Naviculae, 321, 322; movements of,
313.**
- Needles for dissection, mode of
mounting, 211.**
- Nematoid Entozoa, 620—622.**
- Nepenthes, spiral vessels of, 425.**
- Nervous Tissue, structure of, 723—
725; mode of examining, 725, 726.**
- Newt, circulation in larva of, 729.**
- Nicol-Prism, 135.**
- Nobert's Test, 203, 204.**
- Noctiluca, 546, 547.**
- Nostochaceae, 347, 348.**
- Notommata, 494, 501.**
- Nucleus of Vegetable cells, 268, 415;
of Infusoria, 480.**
- Nudibranchs, development of, 609,
610.**
- Nummulite, structure of, 515, 749—
753.**
- Nuphar lutea, parenchyma of, 411.**
- Object-Finder, 121—123.**
- Object-glasses, achromatic, principle
of, 49, 50; construction of, 50—52;
adjustment of, for covering of ob-
ject, 52—54, 166—169; defining
power of, 192, 193; penetrating
power of, 193; resolving power of,
193—195; flatness of field of, 195;
comparative value of, 194—198;
different powers of, 199—203; tests
for, 199—206; determination of
magnifying power of, 206, 207.**
- Object-glass holder, Mr. Brooke's,
118, 119.**
- Object-Marker, 119.**
- Objects, mode of mounting, dry, 232—
236; in Canada balsam, 236—244;
in preservative fluids, 244—257;
see Opaque and Transparent Ob-
jects.**
- Oblique Illuminators, 129—132, 176,
177.**
- Ocelli of compound eyes of Insects,
657.**
- Edogonium, zoospore of, 354; sexual
reproduction of, 355.**
- Oil-globules, microscopic appearances
of, 189.**
- Oleander, cuticle of, 445.**
- Oncidium, spiral cells of, 419.**
- Onion, raphides of, 422.**
- Oolite, structure of, 749.**
- Opaque Objects, arrangement of Mi-
croscope for, 178—180; various
modes of illuminating, 180—184;
modes of mounting, 233—236.**
- Opercula of Mosses, 396.**
- Ophocoma, 560.**
- Ophiurida, skeleton of, 559, 560.**
- Ophrydina, 487.**
- Orbitoides, structure of, 753—755.**
- Orbitolite, structure and development
of, 507—514.**
- Ornithorhynchus, hair of, 700.**
- Oscillatoriaceae, 346, 347.**
- Ovipositors, 678—680.**
- Ovules of Phanerogamia, 457; ferti-
lization of, 18, 457, 458; mode of
studying, 458—460.**
- Owen, Prof., on Fossil Teeth, 757—
759; on Fossil Bone, 759, 760.**
- Oxytricha-form of Trichoda, 484, 485.**
- Palm, stem of, 429, 430.**
- Palmellaceae, 340—342.**
- Palmoglaea macrococca, life-history
of, 267—270.**
- Pampean deposit, organic composi-
tion of, 755.**
- Papillæ of skin, structure of, 713,
724; of tongue, 725.**
- Parabolic Illuminator, 133, 134.**
- Paramecium, 474, 475; contractile
vesicle of, 479; multiplication of,
480.**
- Parasitic fungi, 376—385.**
- Pearls, structure of, 594—596.**
- Pecari, hair of, 700.**
- Pecten, eyes of, 616; tentacles of, 617.**
- Pediastrum, multiplication and devel-
opment of, 291—294.**
- Pediculariæ of Echinoderms, 558,
559.**
- Penetrating power of object-glasses,
193.**
- Pentacrinus, skeleton of, 560; larval,
570.**
- Peristome of Mosses, 396, 397.**
- Perophora, 585—587.**
- Petals of Flowers, structure of, 452,
453.**
- Pettenkofer's test, 222.**
- PHANEROGAMIA, elementary tissues
of, 408—428 (see Tissues of Plants);**

- stems and roots of, 428—443; cuticle and leaves of, 443—451; flowers of, 451—460; seeds of, 460—462.
- Phytelphas*, cells of, 418.
- Phyllopora*, 636.
- Pigment-cells, 712.
- Pith, structure of, 431, 432.
- Pinna*, structure of shell of, 589—592.
- Pinnularia*, 322.
- Placoid scales of Fish, 697.
- Planaria*, 623—625.
- Plants, distinction of from Animals, 263, 264, 469, 470.
- Plantago*, rotation in hairs of, 416.
- Pleurosigma*, 322; nature of markings on, 306, 307; value of, as tests, 202—205.
- Pluteus-larva of Echinus, 567—570.
- Podura*, scale of, 202, 651, 653.
- Polarization, objects suitable for, 764.
- Polarizing Apparatus, 135—138.
- Pollen-grains, development of, 454; structure and markings of, 200, 455—457.
- Polycystina*, nature of, 519, 520; distribution of, 521—523.
- Polygastrica*; see Infusoria.
- Polyommatus argus*, scale of, 202, 652, 653.
- Polypes*; see Hydra and Zoophytes.
- Polypodium*, fructification of, 399.
- POLYZOA, 20, 571; general structure of, 571—576; molluscan nature of, 576, 577; classification of, 578—581.
- Potatoe-disease, 385.
- Powell and Lealand's Microscope, 99, 101; their Achromatic Condenser, 126, 127.
- Preservative Liquids, 244—246.
- Primordial utricle, 265.
- Prismatic shell-substance, 589—592.
- Prisms, Dujardin's, 127, 128, 176; Nachet's, 130; Amici's, 131; Grubb's, 131; polarizing, 135, 136.
- Proboscis of Bee, 664, 665; of Butterfly, 665, 666; of Fly, 663, 664.
- Proteus*, 464.
- Protococcus pluvialis*, life-history of, 270—275; various forms of, 275, 276; conditions influencing changes of, 276, 277.
- Protoplasm of vegetable cell, 265.
- ПРОТОФИТА, general characters of, 263, 266.
- Protozoa, 463—469; their relations to Protophyta, 263, 264, 469, 470.
- Pseudopodia, of Rhizopods, 467, 471.
- Pterodactyle*, bone of, 760.
- Puccinia*, 384.
- Purpura*, development of, 609—614.
- Pycnogonida*, 630—632.
- Quekett, Mr., his Dissecting Microscope, 77—79; his Indicator, 115; on structure of Bone, 759, 760.
- Rainey, Mr., his moderator, 156.
- Ramsden's eye-piece, 63, 64.
- Raphides, vegetable, 422, 423.
- Reade, Rev. J. B., on black-ground illumination, 132.
- Re-agents, Chemical, use of in Microscopic research, 220—223.
- Red Corpuscles of blood, 704—706.
- Red Snow*, 340.
- Refraction, laws of, 38, 39; by convex lenses, 39—43; by concave and meniscus lenses, 43, 44.
- Rein-deer*, hair of, 699.
- REPTILES, bone of, 690; teeth of, 694; scales of, 698; blood of, 704—706; lungs of, 736.
- Resolving power of object-glasses, 193—195.
- Roto Mucosum, 711.
- Reticulated Ducts, 426.
- Rhinoceros*, horn of, 703, 704.
- RHIZOPODA, 19, 470, 471.
- Rhubarb*, raphides of, 422.
- Rhynchonella*, structure of shell of, 598—600.
- Rice-Paper, 410.
- Rochea falcata*, 446.
- Rocks, structure of, 755.
- Roots, structure of, 441; mode of making sections of, 441—443.
- Rosalina*, 506.
- Ross, Mr., on adjustment of object-glass, 53, 54.
- his Compound Microscope, 95—99; his Achromatic Condenser, 125, 127; his Simple Microscope, 71—73; his lever of contact, 226; his side-reflector, 141; his eyepiece Micrometer, 112, 113.
- Rotation of fluid in Chara, 361; in cells of Phanerogamia, 412—417.
- Rotifer*, anatomy of, 492—494; reproduction of, 496; desiccation of, 497; occurrence of, in leaf-cells of Sphagnum, 490.
- ROTIFERA, 29, 473; general structure of, 490—495; reproduction of, 495—497; desiccation of, 497; classification of, 497—501.
- Rush*, stellate parenchyma of, 411.
- Rust, of Corn, 394.
- Sable*, hair of, 699.
- Sarcoc, 464—466.
- Saw-flies*, ovipositor of, 679.
- Scalariform ducts of Ferns, 398, 399,

- Scales, of cuticle of Plants, 446.
 ——— of Fish, 694—698.
 ——— of Insects, 650—656; their use as test-objects, 201.
 ——— of Reptiles and Mammals, 698.
- Schacht on fertilization of ovule, 457—459.
- Schleiden, Prof., his researches, 12; on fertilization of ovule, 457—459.
- Schultz, Prof., his experiments on development of Infusoria, 485, 486.
- Schultz's solution, 222.
- Schwann, doctrines of, 28.
- Scissors for microscopic dissection, 208—210; for cutting thin sections, 212.
- Sclerogen, deposit of, on walls of cells, 417.
- Sea-Anemone*, 540—552.
- Sealing-wax varnish, 229.
- Section-Instrument, 213—215.
- Sections, thin, mode of making, of soft substances, 212, 213; of substances of medium hardness, 213—215; of hard substances, 215—220; of Wood, 441—443; of Echinus-spines, 560—562; of Bones and Teeth, 690; of Hairs, 702.
- Seeds, microscopic characters of, 460, 462.
- Segmentation of Yolk-mass, 609.
- Selenite-Plate, 137.
- Self-division of cells; see Duplicative Subdivision.
- Scorop membranes, structure of, 711.
- Sertularida*, 538—538.
- Shadbolt, Mr., on Arachnoidiscus, 317.
 ——— his Annular condenser, 133; his Turn-table, 249.
- Shark*, teeth of, 691, 692; scales, &c., of, 697.
- Shell, of Crustacea, 643, 644; of Echinida, 553, 554; of Mollusca 589—603.
- Side-Reflector, Ross's, 141.
- Siliceous Cuticles, 405, 446, 447.
- Silk-worm disease, 377.
- Simple Microscope, principle of, 54—59; various forms of, 70—79.
- Siphonaceæ*, 348—352.
- Skin, structure of, 710—713; papillæ of, 713, 724.
- Slider-forceps, 238.
- Slides, glass, 224.
 ——— wooden, 232, 233.
- Slug*, rudimentary shell of, 602.
- Smith, Prof. W., on Diatomaceæ, 332, 333.
- Smith and Beck's Dissecting Microscope, 89—91; their Large Compound Microscope, 101—103; their Achromatic Condenser, 126; their Student's Microscope, 87, 88; their Educational Microscope, 89 *note*, 765.
- Snake*, lung of, 736.
- Snow-crystals, 761.
- Sole*, skin and scales of, 695, 696.
- Sollitt's Achromatic Condenser, 130.
- Sorby, Mr., his microscopic examination of rocks, 758.
- Spatangus*, spines of, 558.
- Speculum-disk for drawing, 117.
- Spencer, Mr., his object-glasses, 51 *note*.
- Spermatia of Lichens, 374; of Fungi, 387.
- Spermogonia of Lichens, 373; of Fungi, 387.
- Sphacelaria*, 367.
- Sphagnum*, peculiar cells of, 392, 393; occurrence of Rotifer in leaf-cells of, 490.
- Sphæria*, development of, within animals, 379.
- Sphaeroplea*, sexual reproduction of, 354.
- Sphaerosira volvox*, 284.
- Spherical Aberration, 45; means of reducing and correcting, 46, 47.
- Spicules of Sponges, 524—526; of Aleyonian Zoophytes, 548, 549; of Tunicated Mollusks, 581; of Doris, 602.
- Spiders*, eyes of, 683; respiratory organs of, 684; feet of, 684; spinning apparatus of, 684, 685.
- Spinal Cord, mode of preparing sections of, 726.
- Spines of Echinus, &c., 555—558; mode of making sections of, 560—562.
- Spinning-apparatus of Spiders, 684, 685.
- Spiracles of Insects, 669—672.
- Spiral Vessels, 424, 425.
- SPONGES, their structure, 523, 524; ciliary action in, 524; skeleton of, 524—526; reproduction of, 526; examination of, 527; fossil, 747.
- Sporangia, of Desmidiaceæ, 296, 297; of Diatomaceæ, 310—312; of Fuci, 369.
- Spores of Hepaticæ, 391; of Mosses, 397, 398; of Ferns, 401, 402; of Equisetaceæ, 406.
- Spotted Lens, 133.
- Spring-press, 239.
- Spirogyra*, 356.
- Squirrel*, hair of, 699, 700.
- Stage, lever, 120, 121; magnetic, 123.
 ——— movements of, 97, 98.
- Stage-Forceps, 143.

- Stage-Plate, glass, 144.
 Stanhope lens, 58, 59.
 Star-Anise, cells of seed-coat of, 417, 418.
 Starch Granules in cells, 420, 421; appearance of, by polarized light 420, 421.
Staurostrum, prominences of, 285, 286; self-division of, 290; varieties of, 295.
 Stein, Dr., his researches on Infusoria, 481—483.
 Stellate cells of Rush, 411; of water-lily, 411.
 Stemmata of Insects, 659.
 Stems, Endogenous, structure of, 428—430.
 ——— Exogenous, structure and development of, 431—441.
 ——— Mode of making sections of, 441—443.
Stentor, 487.
Stephanoceros Eichornii, 489.
Stickleback, circulation in, 729.
 Stigmata of Insects, 669—672.
 Stings, structure of, 678, 679.
 Stomata of Marchantia, 388, 389; of Flowering Plants, 447—449.
Suctorul Crustacea, 640, 641.
 Sumnski, Count, on development of Ferns, 16.
Surirella, 321; conjugation in, 310.
 Swarming, of Desmidiaceæ, 291.
Synapta, calcareous skeleton of, 563, 564.
Tadpole, pigment-cells of, 712, 713; mode of viewing circulation in, 729.
Tænia, 618, 619.
Tardigrada, 501; desiccation of, 497
 Teeth, of Echinida, 559; of Mollusks, 603—608; of Leech, 629; of Vertebrata, structure of, 691—694; fossil, 757—759; mode of making sections of, 215—220, 690.
Terebellu, circulation and respiration in, 626, 627.
Terebratula, structure of shell of, 598—600.
 Test-Bottles, 221, 222.
 Test-Liquids, 222, 223.
 Test-Objects, 198—206.
 Tetraspores of Floridææ, 371, 372.
Thalassicolla, 514.
Thaumantias, 540, 541.
 Thecæ of Fungi, 375, 376; of Ferns, 399, 400.
 Thin Glass, 224—227.
 Thompson, Mr. J. V., on Polyzoa, 571; on metamorphosis of Cirripeds, 641—643; on metamorphoses of Crustacea, 644—646.
 Thread-cells of Zoophytes, 550—552.
 Thread, glutinous, of spider's web, 684, 685.
 Thrush, fungous vegetation of, 382.
 Thwaites's fluid for Algeæ, 245.
Ticks, 682.
Tinea favosa, fungous vegetation of, 382.
 Tissues, Elementary, of Animals, microscopic study of, 25—27, 686; independent life of, 28, 29;—see Blood, Bone, Capillaries, Cartilage, Epidermis, Epithellum, Fat, Feathers, Fibrous Tissues, Glands, Hair, Horn, Mucous Membranes, Muscle, Nervous Tissues, Pigment-cells, Scales, Serous Membranes, Teeth.
 Tissues, Elementary, of Plants, 408; Cellular, 408—412; varieties of, 417—423; woody, 423; fibro-vascular, 423; vascular 424, 425; vasi-form, 425—427; dissection of, 427, 428.
 Tongues of Gasteropods, 603—607; of Insects, 662—665.
Torula cerevisia, 374, 375.
 Tracheæ of Insects, 668—671; mode of preparing, 672, 673.
Tradesantia, rotation in hairs of, 415, 416.
 Transparent Objects, arrangement of Microscope for, 169—174; various modes of illuminating, 174—178.
Trematode Entozoa, 622, 623.
 Trembley, his researches on the Hydra, 6.
Triceratium, 319, 320; markings on, 305.
Trichoda lynceus, bristles of, 476; metamorphoses of, 483—485.
Trilobite, eye of, 757.
 Triplet, Microscopic, 57.
Trout, circulation in young, 729.
Tubulariæ, 535, 536, 538.
 Tubules, nervous, 723, 724.
 TUNICATA, Compound, general organization of, 581—584; different types of, 584—586; alternating circulation in, 586, 587; development of, 587, 588.
Turbellaria, 623—625.
 Turn-table, Shadbolt's, 249.
Ulveæ, 343—345.
Unionidæ, shells of, 592, 597.
Uredo, 384.
 Urns of Mosses, 396, 397.
 Vacuoles, microscopic appearances of, 190.
 Valentin's knife, 213.
Vallisneria spiralis, rotation in, 412, 413.

- Varnishes useful to Microscopists, 227—229, 766.
- Vasiform Tissue, 425—427.
- Vaucher, his researches on *Confervæ*, 7.
- Vaucheria*, 348; zoospores of, 348, 349; sexual reproduction of, 348, 350.
- Vegetable Organization, general nature of, 264; see Plants.
- Vegetable Cell, nature of, 265, 266.
- Vegetable Ivory, 418.
- VERTEBRATA, elementary structure of, 686—726 (see Tissues); blood of, 704—707; circulation in, 726—729; development of, 738.
- Vesicles of Nervous tissue, 723, 724.
- Vibracula of Polyzoa, 579, 580.
- Villi of intestine, injections of, 736.
- Vine-disease, 365.
- Volvox*, structure of, 277—280; development of, 280—285.
- Von Baer's law of development, 23.
- Vorticella*, 477, 487; encysting process in, 481, 482.
- Warrington's Universal Microscope, 91—95.
- Water-vascular system, of Rotifera, 494, 495; of Entozoa, 619. /
- Wenham, Mr., his Parabolic Speculum, 133.
- his observations on rotation, 414—417.
- Whalebone, structure of, 703, 704.
- Wheel-Animalcules*; see Rotifera.
- White-Cloud Illuminator, 128, 176.
- White Corpuscles of blood, 704—707.
- White Fibrous tissue, 709.
- Williamson, Prof., on *Volvox*, 280—285.
- Wings of Insects, 673—676.
- Winter-eggs of Rotifera, 496; of Hydra, 532; of Entomostraca, 639.
- Wood, of Exogenous stems, 432—437.
- Woody Fibre, 423; glandular, of Coniferæ, 424.
- Xanthidia* of Flints, 747.
- Yeast, a vegetable substance, 15; production of, 15, 374, 375.
- Yellow fibrous tissue, 709, 710.
- Yellow Water-lily, parenchyma of, 411.
- Fucca*, stomata of, 447, 448.
- Zoophyte-Trough, 146, 147.
- ZOOPHYTES, 528; Hydraform, 532—538; preparation of, for microscope, 538—540; development of Medusæ from, 23, 24, 540—544; Alcyonian, 547—549; Actiniform, 549—552.
- Zoospores, formation of, by Ulvaceæ, 344, 345; by *Vaucheria*, 348, 349; by *Achlya*, 350, 351; by *Confervaceæ*, 354, 355; by *Charophoraceæ*, 357; by *Fucaceæ*, 370, 371.

CHURCHILL'S MANUALS.

Fcap. 8vo, cloth, price 12s. 6d. each Volume.

~~~~~  
**Aggregate Sale, 75,500 Copies.**  
~~~~~

- ANATOMY : Mr. ERASMUS WILSON.
CHEMISTRY : Mr. FOWNES.
MATERIA MEDICA : Dr. ROYLE.
MEDICAL JURISPRUDENCE : Dr. TAYLOR.
MEDICINE : Dr. BARLOW.
MICROSCOPE : Dr. CARPENTER.
NATURAL PHILOSOPHY : Dr. G. BIRD and
Mr. BROOKE.
OPHTHALMIC MEDICINE : Mr. WHARTON JONES.
PATHOLOGICAL ANATOMY : Dr. H. JONES
and Dr. SIEVEKING.
PHYSIOLOGY : Dr. CARPENTER.
POISONS : Dr. TAYLOR.
SURGERY : Mr. FERGUSSON.

A CATECHISM OF CHEMICAL PHILOSOPHY :

being a Familiar Exposition of the Principles of Chemistry and Physics. With Engravings on Wood. Designed for the Use of Schools and Private Teachers. By JAMES HORSLEY. Post 8vo. 6s. 6d. cloth.

"The little work before us is extremely well adapted for the instruction of the young, and on this account it is very likely to become extensively used in schools. It should be placed in the hands of every intelligent boy, for the principal facts of the science of chemistry should be taught to all. It is by no means uncommon to meet with persons of intelligence and of decent education who are quite incapable of comprehending the simplest explanations of ordinary chemical facts and laws. We urge every parent to take care that his son shall obtain some acquaintance with chemistry, he has only to place in his hand an elementary treatise, a small, easy, and familiar book, we know of none better than Mr. Horsley's for the purpose."

The Chemist.

A MANUAL OF PHOTOGRAPHIC CHEMISTRY, including the Practice of the Collodion Process. By T. FREDERICK HARDWICH, late Demonstrator of Chemistry, King's College, London. Second Edition, fcap. 8vo. cloth, 6s. 6d.

FOWNES'S MANUAL OF CHEMISTRY. Edited by H. BENCE JONES, M.D., F.R.S., and A. W. HOFFMANN, Ph.D.F.R.S. Fifth Edition, fcap. 8vo. cloth, 12s. 6d.

ELEMENTS OF NATURAL PHILOSOPHY :

being an Experimental Introduction to the Study of the Physical Sciences. By GOLDING BIRD, M.D., F.R.S., and CHARLES BROOKE, F.R.S. Fourth Edition, with numerous Engravings on Wood. Fcap. 8vo. cloth, 12s. 6d.

"This work marks an advance which has long been wanting in our system of instruction. Dr Bird has succeeded in producing an elementary work of great merit."—*Athenæum*.

"We should like to know that Dr. Bird's book was associated with every girls' and boys' school throughout the kingdom."—*Medical Gazette*.

"A volume of useful and beautiful instruction for the young"

Literary Gazette

CHEMICAL DIAGRAMS. By ROBERT GALLOWAY.

On Four large Sheets, for School and Lecture Rooms. Price 5s. 6d. the Set.

THE FIRST STEP IN CHEMISTRY. By the same Author. Second Edition, fcap. 8vo. cloth, 5s.

CHEMISTRY, AS EXEMPLIFYING THE WISDOM and BENEFICENCE of GOD. By GEORGE FOWNES, F.R.S. Second Edition, fcap. 8vo. cloth, 4s. 6d.

PRACTICAL CHEMISTRY, including ANALYSIS. With numerous Illustrations on Wood. By JOHN E. BOWMAN, Professor of Practical Chemistry in King's College, London. Second Edition, fcap. 8vo. cloth, 6s. 6d.

ON THE USE OF THE BLOWPIPE. Illustrated by numerous Diagrams. By Professors PLATTNER and MUSPRATT. Third Edition, 8vo. cloth, 10s. 6d.

HANDBOOK OF CHEMISTRY: THEORETICAL, PRACTICAL, and TECHNICAL. By F. A. ABEL, F.C.S., Chemist to the Board of Ordnance, and C. L. BLOXAM, Demonstrator of Practical Chemistry in King's College. 8vo. cloth, 15s.

FRESENIUS'S INSTRUCTIONS IN CHEMICAL ANALYSIS. Edited by LLOYD BULLOCK.

QUALITATIVE. Third Edition, 8vo. cloth, 9s.

QUANTITATIVE. Second Edition, 8vo. cloth, 15s.

CHEMISTRY OF THE FOUR SEASONS:—SPRING, SUMMER, AUTUMN, WINTER. Illustrated with Engravings on Wood. By THOMAS GRIFFITHS. Second Edition, fcap. 8vo. cloth, 7s. 6d.

London. JOHN CHURCHILL, New Burlington-street.

