

UNITED STATES
DEPARTMENT OF
COMMERCE
PUBLICATION



National Bureau of Standards
Library, E-01 Admin. Bldg.

APR 16 1970

NBS TECHNICAL NOTE 522

Beam Handling Techniques for Electron Linear Accelerators

U.S.
DEPARTMENT
OF
COMMERCE
National
Bureau
of
Standards

NATIONAL BUREAU OF STANDARDS

The National Bureau of Standards¹ was established by an act of Congress March 3, 1901. Today, in addition to serving as the Nation's central measurement laboratory, the Bureau is a principal focal point in the Federal Government for assuring maximum application of the physical and engineering sciences to the advancement of technology in industry and commerce. To this end the Bureau conducts research and provides central national services in four broad program areas. These are: (1) basic measurements and standards, (2) materials measurements and standards, (3) technological measurements and standards, and (4) transfer of technology.

The Bureau comprises the Institute for Basic Standards, the Institute for Materials Research, the Institute for Applied Technology, the Center for Radiation Research, the Center for Computer Sciences and Technology, and the Office for Information Programs.

THE INSTITUTE FOR BASIC STANDARDS provides the central basis within the United States of a complete and consistent system of physical measurement; coordinates that system with measurement systems of other nations; and furnishes essential services leading to accurate and uniform physical measurements throughout the Nation's scientific community, industry, and commerce. The Institute consists of an Office of Measurement Services and the following technical divisions:

Applied Mathematics—Electricity—Metrology—Mechanics—Heat—Atomic and Molecular Physics—Radio Physics²—Radio Engineering²—Time and Frequency²—Astrophysics²—Cryogenics.²

THE INSTITUTE FOR MATERIALS RESEARCH conducts materials research leading to improved methods of measurement standards, and data on the properties of well-characterized materials needed by industry, commerce, educational institutions, and Government; develops, produces, and distributes standard reference materials; relates the physical and chemical properties of materials to their behavior and their interaction with their environments; and provides advisory and research services to other Government agencies. The Institute consists of an Office of Standard Reference Materials and the following divisions:

Analytical Chemistry—Polymers—Metallurgy—Inorganic Materials—Physical Chemistry.

THE INSTITUTE FOR APPLIED TECHNOLOGY provides technical services to promote the use of available technology and to facilitate technological innovation in industry and Government; cooperates with public and private organizations in the development of technological standards, and test methodologies; and provides advisory and research services for Federal, state, and local government agencies. The Institute consists of the following technical divisions and offices:

Engineering Standards—Weights and Measures—Invention and Innovation—Vehicle Systems Research—Product Evaluation—Building Research—Instrument Shops—Measurement Engineering—Electronic Technology—Technical Analysis.

THE CENTER FOR RADIATION RESEARCH engages in research, measurement, and application of radiation to the solution of Bureau mission problems and the problems of other agencies and institutions. The Center consists of the following divisions:

Reactor Radiation—Linac Radiation—Nuclear Radiation—Applied Radiation.

THE CENTER FOR COMPUTER SCIENCES AND TECHNOLOGY conducts research and provides technical services designed to aid Government agencies in the selection, acquisition, and effective use of automatic data processing equipment; and serves as the principal focus for the development of Federal standards for automatic data processing equipment, techniques, and computer languages. The Center consists of the following offices and divisions:

Information Processing Standards—Computer Information—Computer Services—Systems Development—Information Processing Technology.

THE OFFICE FOR INFORMATION PROGRAMS promotes optimum dissemination and accessibility of scientific information generated within NBS and other agencies of the Federal Government; promotes the development of the National Standard Reference Data System and a system of information analysis centers dealing with the broader aspects of the National Measurement System, and provides appropriate services to ensure that the NBS staff has optimum accessibility to the scientific information of the world. The Office consists of the following organizational units:

Office of Standard Reference Data—Clearinghouse for Federal Scientific and Technical Information³—Office of Technical Information and Publications—Library—Office of Public Information—Office of International Relations.

¹ Headquarters and Laboratories at Gaithersburg, Maryland, unless otherwise noted; mailing address Washington, D.C. 20234.

² Located at Boulder, Colorado 80302.

³ Located at 5285 Port Royal Road, Springfield, Virginia 22151.

UNITED STATES DEPARTMENT OF COMMERCE
Maurice H. Stans, Secretary
NATIONAL BUREAU OF STANDARDS • Lewis M. Branscomb, Director



TECHNICAL NOTE 522

ISSUED APRIL 1970

Nat. Bur. Stand. (U.S.), Tech. Note 522, 21 pages (Apr. 1970)

CODEN: NBTNA

Beam Handling Techniques for Electron Linear Accelerators

Samuel Penner

Linac Radiation Division
Center for Radiation Research
National Bureau of Standards
Washington, D.C. 20234

NBS Technical Notes are designed to supplement the Bureau's regular publications program. They provide a means for making available scientific data that are of transient or limited interest. Technical Notes may be listed or referred to in the open literature.

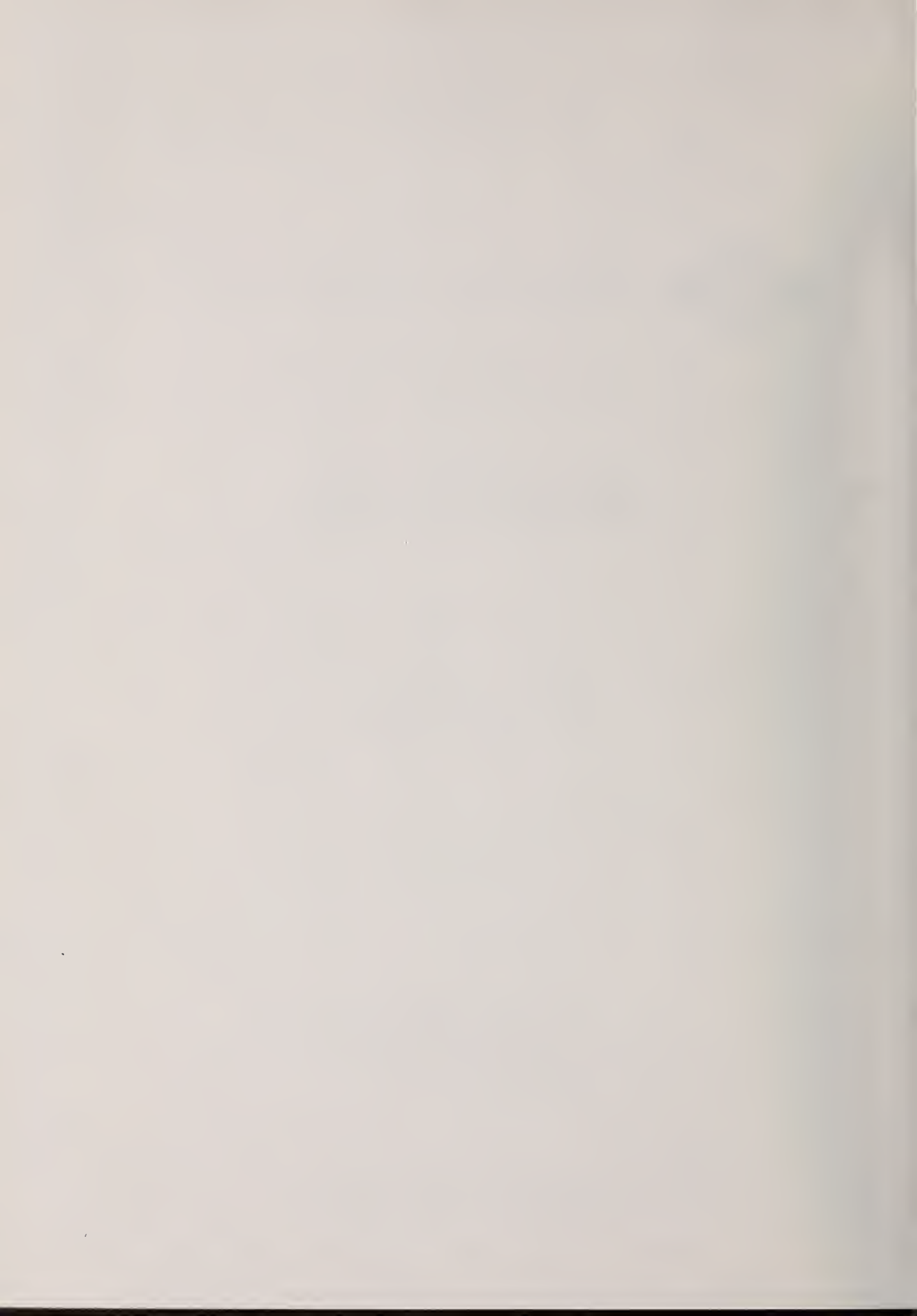

FOREWORD

This report was originally prepared for presentation at a Seminar on the subject "Nuclear Investigations on Linear Electron Accelerators at Low and Medium Energy", held at the P. N. Lebedev Physical Institute, Moscow, USSR, December 10-16, 1969. The paper presents a fairly extensive review of beam handling techniques for high current electron linear accelerators and particularly of the NBS facility which has not been fully described elsewhere. The paper is therefore reproduced here in its original form in order to be available to a wider audience.

CONTENTS

	Page
1. Introduction.....	1
2. Beam Optics.....	1
3. Beam Diagnostics and Control.....	11
4. Handling High Power Beams.....	14
5. Summary.....	16
6. References.....	18

S. Penner

The design of beam transport systems for electron linear accelerators intended for nuclear physics research is discussed. The subjects covered include beam optics, diagnostics and control of electron beams, and problems of handling high power beams.

Key Words: beam handling; beam optics; beam transport; electron linear accelerator; instrumentation for electron beams; linac.

1. Introduction

A suitable beam transport system connecting the accelerator with the experimental apparatus is an essential part of any experimental program using an electron linac. Major progress in both theoretical understanding and experimental techniques has been made during the last ten years so that, using presently available methods, electron beams of excellent quality can be provided to suit the needs of the most exacting experiments. Without referring to any specific experiment, we can define the main properties demanded of the beam transport system. These include: good momentum resolution and stability, small and stable beam focal spots at experimental targets, low backgrounds in experimental areas, beam purity (absence of x-rays and low energy electrons), matching to the accelerator to obtain good current, and the ability to handle the beam power of the accelerator. In this report we will discuss the methods by which these properties are achieved and the quality of the beams which have been obtained in operating systems.

2. Beam Optics

Most linacs produce an electron beam with a momentum spread of 1 to

5 percent, a diameter of the order of 1 cm, and a divergence of about 1 milliradian or less. Typical experiments demand momentum spreads as small as a few parts in 10^4 and focal spots of the order of 1mm. With rare exceptions, existing installations employ achromatic beam transport systems to achieve these properties. The term achromatic is used here to mean that the electrons which have passed through a momentum-defining aperture are reassembled into a final beam in which the orbits are independent of the electrons's momentum (or very nearly so). A typical achromatic system is shown in figure 1^{1/*}.

The main reasons for using an achromatic system are: (1) it is very much easier to transport the beam along the final beam path than if it were appreciably dispersed; (2) a small focal spot may be obtained at any point along the path by a simple pair of quadrupole magnets, permitting multiple experimental setups along a single beam line; and (3) there is no dependence of beam direction on momentum, which might cause problems in experiments where the angular distribution of the reaction products is strongly anisotropic (as in electron scattering). In addition the deflecting magnet which is located after the momentum-defining aperture provides a strong discrimination against x-rays and degraded electrons generated at the aperture, thus sharply reducing the background in the experimental area.

The particular system of figure 1 has the additional property that an initially parallel beam is transformed to a parallel final beam. Although this is not a general property of achromatic systems it is useful because the beam obtained from the linac is very nearly parallel, literature references at the end of this paper.

and particularly desirable when several experimental setups are located along a single beam path. At the NBS linac, a system of this design provides beam to any of five experiments which occupy a beam path length of nearly 25 meters.

In principle, the momentum-defining aperture for the system of figure 1 could be located at the symmetry plane of the system. Aside from the mechanical problems involved in locating an adjustable aperture inside a quadrupole magnet, this would be a poor location for the aperture because changes in beam steering along the linac would change the momentum bin passed by the aperture. In the NBS system this effect would be 1.4×10^{-3} fractional momentum change per milliradian change in beam direction. Therefore, an entrance aperture (CA in figure 1) is installed between the linac and the beam transport system, and the momentum-defining aperture (E) is located at the point where the first deflecting magnet (D1) and central quadrupole (Q0) form an image of CA (in the horizontal plane optics). These apertures guarantee that the momentum of the beam selected by aperture E is independent of linac steering.

Careful design of the slit edges in the momentum defining aperture is necessary in order to minimize low-energy tails in the transmitted beam. Electrons which just graze the edge of the slit should be made to suffer as much energy loss and multiple scattering as possible so that they can be effectively absorbed in clean-up collimators before entering the experimental area. The way to accomplish this aim is to have a large radius of curvature slit-edge made of high Z material. Figure 2 shows the NBS energy slit design. The radius of curvature of

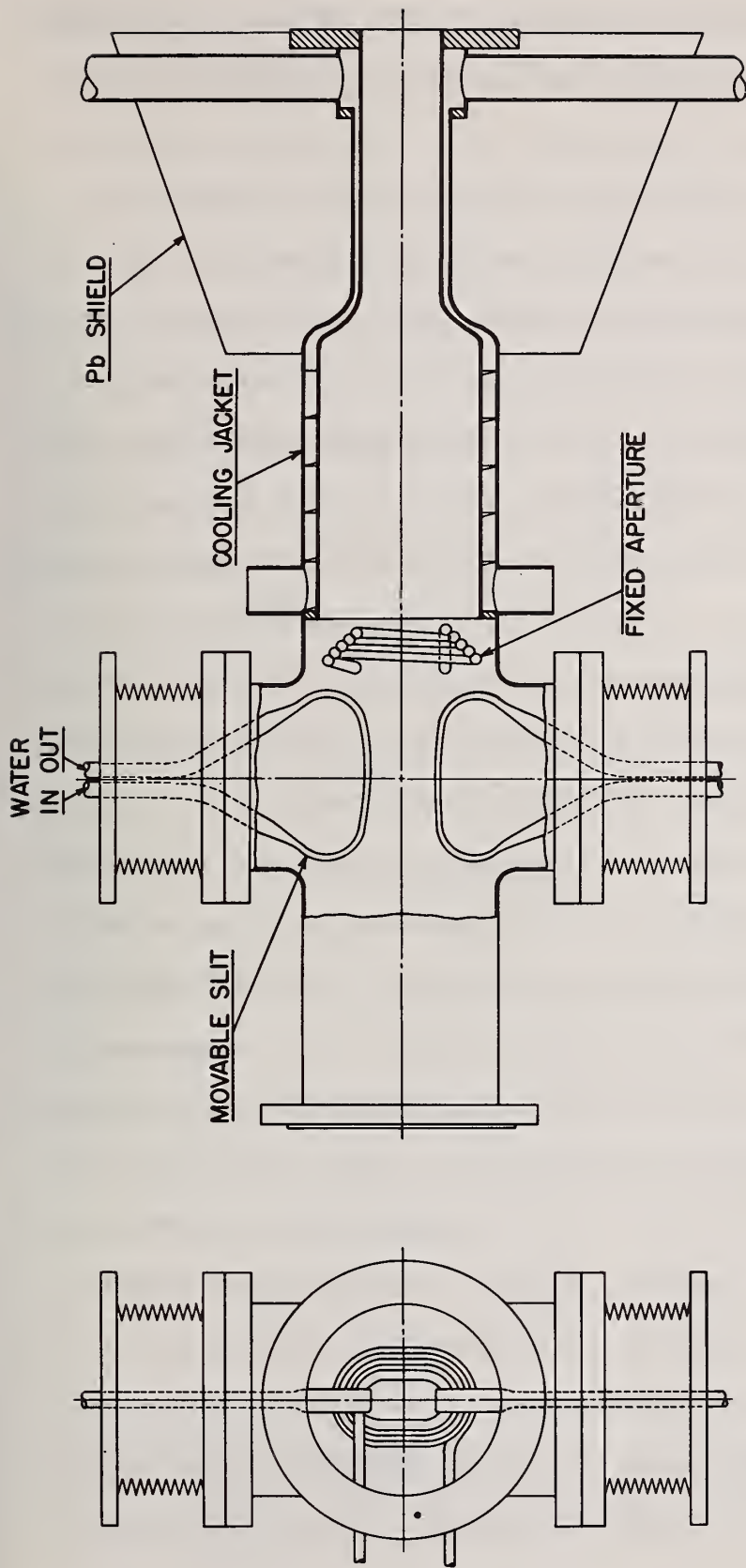

Figure 2. Momentum-defining aperture collimator design. The movable slits are formed from copper tubing, with the surfaces nearest to the beam gold plated. The two slits are opened and closed symmetrically about the center line by a motor and gear drive arrangement not shown in the figure. Metal bellows allow the slits to move inside the vacuum system without the need of sliding vacuum seals. The fixed aperture behind the movable slits serves to further scatter electrons which have hit the slits or to intercept the beam if the slits are opened wide. This is necessary to prevent direct beam impingement on the vacuum system walls. Both the movable slits and the fixed aperture are cooled internally by high velocity (about 13 m/sec) water flow to prevent thermal failure. The lead shield, which is also water cooled, absorbs most of the energy of the shower generated in the slits.

the edge is about 0.5m. The slit edges are made of water-cooled copper (because of heat removal requirements), on which a .05mm gold surface layer is evaporated.

It is important to note that the distance from CA to the first deflecting magnet should be as large as possible (about 5m in the NBS system where the bending radius is 0.7m). The reason is that if CA were moved closer to the deflecting magnet, its image would move farther downstream from Q0. The magnification of the image would increase but the dispersion would decrease rapidly. Thus to obtain a given resolution, the horizontal opening of CA would have to be decreased, resulting in reduced beam current. In the NBS system the dispersion at E is .092%/mm and the magnification of CA at E is -.26. Our highest resolution electron scattering work is done with the CA opening set at 2.5mm, resulting in a momentum spread of 0.06 percent (FWHM).

Although a beam transport system demands a reduction of beam size for high resolution operation it may be capable of accepting a more divergent beam than that produced by the linac. The phase space emittance of the beam can be more closely matched to the acceptance of the beam transport system by means of quadrupole lenses (QA, QB in figure 1) located in front of the entrance aperture CA. These quadrupoles can minimize the reduction of beam current described above. At NBS the angular acceptance of 4 mrad is limited by a 20mm diameter aperture (CB) just in front of the first deflecting magnet. This aperture restricts the beam to the uniform-field region of the deflecting magnets in order to insure good resolution, and prevents impingement of the beam on the vacuum chamber which could cause thermal failure

(discussed in section 4, below) or large background in the experimental area if even a small fraction of the beam impinges on the vacuum pipe along the final beam line. In principle, the quadrupole pair QA, QB, in the NBS system provides a good match of the beam transport system phase acceptance (1 mrad-cm in the horizontal plane for .06% resolution, and 4 mrad-cm in the vertical plane) to the linac emittance (1 to 2 mrad cm)*. In practice, we have not been highly successful in increasing the transmitted current. This seems to be due to a misalignment of the quadrupoles plus a lack of sufficient beam position information and steering control. These problems will be discussed in detail in section 3.

An auxiliary pair of quadrupoles (Q1, Q2, in figure 1) is located just after the last deflecting magnet of the achromatic system. These quadrupoles serve to reduce the divergence of the final beam so that it can be carried for a large distance in reasonable size beam pipe without further focussing. This is particularly important when entrance quadrupoles (QA, QB) are used. One must be very cautious in using the auxiliary quadrupoles because if they are adjusted for too short a focal length they can cause some of the degraded electrons which have been scattered from the momentum-defining aperture to be focussed through the clean-up collimator (CC).

The clean-up collimator and the shielding wall which follows it are the final steps taken to insure high beam purity and low background in the experimental area. The aperture of this collimator should be quite

*We define phase area here as full width of the beam spot times total angular acceptance. The actual 4-dimensional phase volume acceptance of the beam transport system is $(\pi/4)^2$ times the product of horizontal and vertical acceptance.

large because if it is too small it can be a source of more background than it removes. (In the NBS system, CC has an aperture of 5 cm diameter compared to a typical beam size of 1-1.5 cm in this region and a beam pipe diameter of 10 cm).

A final beam focus at the experimental target is obtained with a third pair of quadrupoles (not shown in figure 1) which must be located rather close to the target if small focal spots are desired. The entire system tends to be highly astigmatic, which is usually desirable, for example in electron scattering experiments where the vertical beam spot dimensions must be small in order to obtain good resolution but the horizontal beam size is not critical (we assume that the spectrometer bends in a vertical plane). However, with two pairs of quadrupoles along the final beam line, a wide range of beam sizes and shapes can be obtained at a given target location.

The design of beam transport systems of the type we have been describing has become a highly developed art. The initial design follows from the principles of first-order optics, and calculations are easily performed by the transport matrix technique^{1/}. For high-quality systems, where resolutions of the order of a part in 10^4 are demanded, with phase space acceptances of the order of a few milliradian-centimeters, first order considerations are not sufficient and both geometric and chromatic aberrations must be considered^{2/}. This is most conveniently done with the aid of digital computer programs such as TRANSPORT^{3/}, which has been developed at SLAC and is in quite general use in many laboratories.

Careful alignment of all components in the beam transport system

is required for proper operation. The TRANSPORT program^{3/} allows one to study the alignment tolerances of the components. Alignment accuracy of 0.1 to 0.2 mm is typically needed for good performance of the system. At NBS, we were probably not sufficiently careful about the alignment when we installed the system. As a result some of the quadrupoles in the system tend to deflect the beam, thus increasing the difficulty of steering the beam properly.

Figure 3 is an overall view of the NBS beam transport system. In addition to the two-magnet-and-quadrupole achromatic system described above, another achromatic system of the three magnet type^{1/} is also shown. The latter type of system tends to have smaller aberrations than the former, but due to the smaller dispersion at the momentum-defining aperture and poorer rejection of degraded electrons generated at the slits in the three magnet system, the two-magnet-and-quadrupole arrangement seems preferable when good resolution is of primary concern.

Figure 3 also reveals what we believe to be a mistake in the general beam layout in our laboratory: The two deflection systems shown (and a third system now being installed at the end of the straight beam line) are in parallel, in the sense that each system operates directly on the straight-ahead beam from the linac. It would have been better to have a single achromatic analysis system, followed by as many deflecting systems as desired. In this scheme only one small region of the transport system must be capable of handling the high beam power continuously (assuming adequate interlocking against accidental beam impingement thereafter), resulting in considerable cost savings and simplified operation. Since the laboratory was already built before we understood this

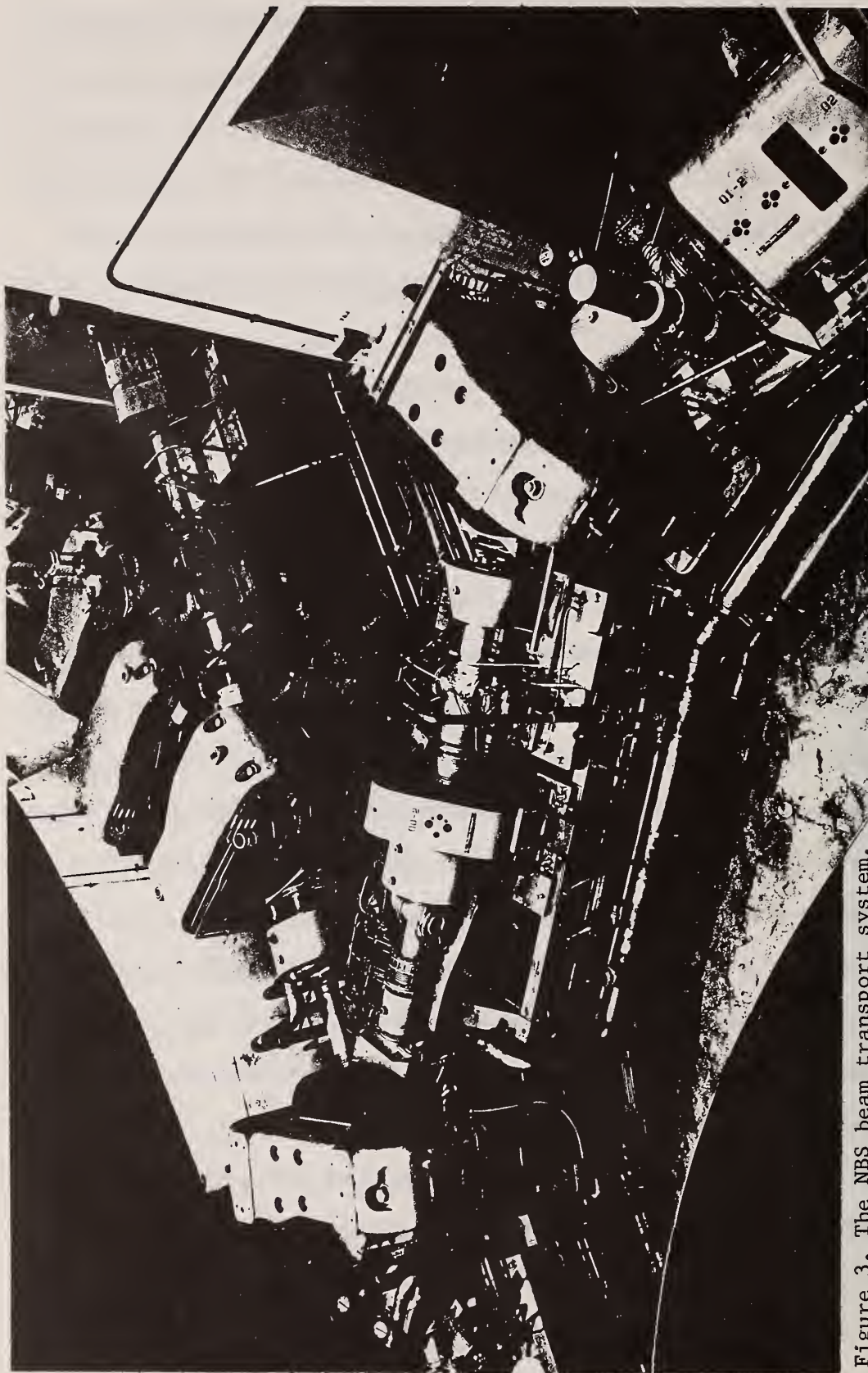

Figure 3. The NBS beam transport system.

In addition to the 90° achromatic deflection system which is described in the text and figure 1, the 45° system composed of three deflecting magnets, and a portion of the straight beam path leading to the next deflecting system downstream can be seen.

point, it is impossible for us to change the layout of the transport system.

3. Beam Diagnostics and Control

We cannot overemphasize the importance of including adequate beam monitoring instrumentation in the beam transport system, as well as along the linac itself. To demonstrate this point, we note that in the NBS system the steering and focussing provided between the linac and an experimental target has at least 14 adjustable parameters along each path. There is some simplification due to the fact that the steering and focussing power supplies derive their reference voltage from the same source as the deflecting magnet power supply and thus tend to "track" when the momentum setting is changed. This tracking is not perfect due to the differing magnetic saturation properties of various components and presence of stray magnetic fields. Even more important are steering and focussing changes needed to account for changes in beam direction, size, and divergence when the current, energy, or other operating parameters of the linac are changed. It is obviously a very difficult job to optimize a system with so many adjustable parameters without good beam monitoring information.

At NBS, the instrumentation provided when the facility was built was not adequate. With each improvement in our beam monitoring or controls we have obtained large benefits in ease of operation, quality of beams achieved, and the speed with which the operating staff can provide conditions requested by the experimenters. In principle we would like to have a position monitor associated with (that is, a few meters downstream from) each steering element and a beam-spot viewer for each pair of

quadrupoles, as well as current monitors regularly spaced along all beam paths.

As a typical example, we will describe the monitoring and controls provided between the output of the linac and the first deflecting magnet of the beam transport system in the NBS system. There are two sets of steering coils between the linac and the entrance aperture (CA in figure 1). Each set provides both vertical and horizontal steering. With these two sets of steerers we can make the beam co-linear with the transport system axis (defined by the centers of CA and CB), independently of the direction and position of the beam leaving the linac. We can observe the beam visually near both CA and CB to determine when the co-linear condition is obtained. It is also necessary to optimize the transmission of the beam through the apertures. This is accomplished with the solenoid focussing coils along the linac as well as the quadrupole pair QA, QB. Adjustment of these elements is monitored by observing the beam spot at the viewscreen near CB. In addition, beam current monitors located at the end of the linac and after CA measure the fraction of the beam current transmitted through CA. This fraction varies between 75 and 100 percent (depending on the beam current and energy) for a 10mm aperture.

The viewers mentioned above are simply fluorescent screens viewed through windows in the vacuum system by a closed-circuit television system. Beryllium oxide wafers serve as convenient viewscreens. This material is useful in the current-density range of about .01 to $1\mu\text{A}/\text{mm}^2$, and has the advantage of being able to withstand considerable beam power. Zinc sulfide (painted on aluminum foil) is more sensitive than beryllium

oxide, but rapidly loses its fluorescent properties with beam impingement, presumably due to radiation damage. At SLAC this difficulty is overcome by providing a large number of interchangeable screens at each station^{4/}. Fluorescent screens are very useful monitors and we use many of them due to their simplicity and relatively low cost. Their main disadvantage is that they intercept the beam and thus must be retracted when not in use.

Non-intercepting beam-position monitors of many types have been developed^{4,5,6/}. Simultaneous display of the beam position at several stations simplifies considerably the alignment of the beam in cases where the number of possible steering adjustments is large (such as along the linac itself). One could also use the signal from a non-intercepting monitor to stabilize the beam alignment by feeding back to the steering coil power supplies. In our experience, this has not been necessary due to the good stability of the linac beam direction, provided that well regulated power supplies are used for the steering coils.

Reliable and reasonably accurate beam current monitoring is obtained with ferrite-core pulse transformers. For pulsed beam currents of about 10mA or greater, the pulse transformer can directly drive a coax cable for oscilloscope display. For smaller pulses, low input impedance current amplifiers are used and careful attention must be given to minimizing electrical pickup^{5/}, which is always a serious problem around pulsed accelerators. In addition to their use in beam control, the current monitors are very useful in protecting the linac and beam transport against accidental beam impingement. The signals from successive monitors along the beam path are fed to difference amplifiers followed by

discriminators. A current difference greater than a preselected value results in an inhibit signal which gates the linac injector pulser off for ~ 2 seconds. In effect then, beam loss between monitor stations causes the beam pulse repetition rate to drop to a very low value until the condition is corrected. The ferrite-core pulse transformers can also be used effectively as average current monitors by means of suitable integrating circuits^{7/}. Although requiring calibration against an absolute current measurement, the ferrite monitors have proven to be very useful for average currents above about $1/2\mu\text{A}$. The precision of current measurements is typically about 0.2%.

4. Handling High Power Beams

The design of a beam transport system for a high current electron linac must explicitly take account of the potential damage which can be done by the high power beam. The problems encountered include: removal of large heat flux from components struck by the beam, fatigue failure of components due to the pulsed nature of the beam, radiation damage to materials, corrosion, residual radioactivity, and chemical effects such as radiolysis of water and production of noxious gases. Since we have recently published a review of these problems and their solutions^{8/}, we will confine our remarks here to a few general comments.

The criteria on which we based the design of components subject to direct beam bombardment seem to be valid, as evidenced by the fact that in four years of regular operation we have never had a component fail due to beam impingement.

Our entire beam transport system is "radiation hard", in the sense that we have not used organic materials in the high radiation areas for

any purpose. However, along the linac there are some organically-insulated cables. This insulation has become extremely brittle due to radiation damage and must be replaced soon, even though the radiation levels along the linac are normally much lower than in the beam transport system. Other than these cables, the only significant radiation damage problem in our laboratory is the darkening of the viewing windows and television camera lenses used with our beam viewing screens. These components must be replaced occasionally, although they recover partially after prolonged exposure to ultraviolet light.

A slow build-up of long-lived residual activities in our beam transport system has occurred, as expected. In the immediate vicinity of the entrance aperture and momentum-selecting slits (CA and E in figure 1) the radiation levels have steady-state values near 1 rad/hr. Fortunately the high radiation areas are quite localized since normally beam impingement occurs only at a few collimating apertures. Each of these is followed by a large lead radiation shield which absorbs most of the energy in the shower resulting from the impingement, in a geometry which provides a high degree of self-shielding. As a result of this localization, a worker will seldom receive a whole-body dose greater than 20mrad during a full working day in the beam transport area. Since the number of times our technicians must work in this area is quite small, the yearly dose received is more than an order of magnitude below the recommended tolerance.

I would like to add one remark on the effective utilization of high-powered accelerators. Obviously one wants the accelerator to operate as nearly continuously as staffing levels and maintenance needs

permit. This can conflict with the needs of experimenters to work on their apparatus. When multiple beam paths are provided the conflict is resolved if adequate shielding between rooms is provided. In our laboratory we have demonstrated both the desirability and practicability of this approach. Radiation levels in rooms not actually traversed by the beam are extremely low, permitting full time occupancy of all such areas.

5. Summary

In conclusion I would like to summarize the state-of-the-art values of electron beam properties. The best operational energy resolution which I know of is the 6×10^{-4} which we use quite routinely for electron scattering at NBS. The new Saclay linac has a design resolution value of $2.4 \times 10^{-4 \frac{9}{}}$, but I believe they have not yet reported an experimental value. The design for the MIT linac now under construction calls for achromatic beam transport with resolution capability of $3.4 \times 10^{-4 \frac{10}{}}$. In addition, the MIT design provides for a dispersive beam with 5.5×10^{-5} resolution, for use with their "energy-loss spectrometer" system^{11/}.

There are obviously other important beam properties besides resolution. Unfortunately, many of these cannot easily be assigned quantitative values. Beam energy stability of a few parts in 10^5 or better ($\pm 2 \text{keV}$ at $60 \text{MeV}^{\frac{12}{}}$) seems to be readily available, depending primarily on the quality of the power supplies for the deflecting magnets. Beam spot sizes of $1 \times 3 \text{mm}$ or less at experimental targets are routinely obtained. The background and beam purity properties of a transport system are also a great importance to the experiments being performed. Achromatic systems of the type described here, when provided with adequate monitor-

ing and control features, are quite capable of satisfying the needs, in this regard, of most experiments.

6. References

1. S. Penner, Rev. Sci. Instr. 32, 150 (1961).
2. Karl L. Brown, Proc. Int. Symposium on Magnet Technology, page 141, Stanford Linear Accelerator Center Report CONF-650922, Stanford, California (1965).
3. S. K. Howry, C. H. Moore, Jr. and H. S. Butler, "TRANSPORT, A Computer Program for Designing Beam Transport Systems", SLAC Internal Report, Stanford Linear Accelerator Center, Stanford, California (1963).
4. R. W. Coombes and D. Neet, IEEE Trans. Nucl. Sci., NS-14, 3, 1111 (1967).
5. J. L. Menke, IEEE Trans. Nucl. Sci., NS-16, 3, 921 (1969).
6. L. Johnston, J. Faust, W. Pierce and M. Stangenes, IEEE Trans. Nucl. Sci., NS-14, 3, 1106 (1967).
7. J. L. Menke, Nucl. Instr. and Methods 64, 1, 61 (1968).
8. S. Penner, IEEE Trans. Nucl. Sci., NS-14, 3, 908 (1967).
9. J. B. Bellicard, P. LeConte and J. Mougey, Medium Energy Nuclear Physics with Electron Linear Accelerators, p. 35, LNS-MIT Report TID-24667 (1967).
10. Medium Energy Nuclear Physics with Electron Linear Accelerators, p. 17, LNS-MIT Report TID-24667 (1967).
11. S. Kowalski, W. Bertozzi and C. P. Sargent, Medium Energy Nuclear Physics with Electron Linear Accelerators, p. 39, LNS-MIT Report TID-24667 (1967).
12. J. E. Leiss, S. Penner, J. E. Rose and J. B. Broberg, IEEE Trans. Nucl. Sci., NS-16, 3, 1027 (1969).

THE NATIONAL ECONOMIC GOAL

Sustained maximum growth in a free market economy, without inflation, under conditions of full employment and equal opportunity

THE DEPARTMENT OF COMMERCE

The historic mission of the Department is "to foster, promote and develop the foreign and domestic commerce" of the United States. This has evolved, as a result of legislative and administrative additions, to encompass broadly the responsibility to foster, serve and promote the nation's economic development and technological advancement. The Department seeks to fulfill this mission through these activities:



MISSION AND FUNCTIONS OF THE DEPARTMENT OF COMMERCE

"to foster, serve and promote the nation's economic development and technological advancement"

Participating with other government agencies in the creation of national policy, through the President's Cabinet and its subdivisions.

- Cabinet Committee on Economic Policy
- Urban Affairs Council
- Environmental Quality Council

Promoting progressive business policies and growth.

- Business and Defense Services Administration
- Office of Field Services

Assisting states, communities and individuals toward economic progress.

- Economic Development Administration
- Regional Planning Commissions
- Office of Minority Business Enterprise

Strengthening the international economic position of the United States.

- Bureau of International Commerce
- Office of Foreign Commercial Services
- Office of Foreign Direct Investments
- United States Travel Service
- Maritime Administration

Assuring effective use and growth of the nation's scientific and technical resources.

- Environmental Science Services Administration
- Patent Office
- National Bureau of Standards
- Office of Telecommunications
- Office of State Technical Services

Acquiring, analyzing and disseminating information concerning the nation and the economy to help achieve increased social and economic benefit.

- Bureau of the Census
- Office of Business Economics

NOTE: This schematic is neither an organization chart nor a program outline for budget purposes. It is a general statement of the Department's mission in relation to the national goal of economic development.



NBS TECHNICAL PUBLICATIONS

PERIODICALS

JOURNAL OF RESEARCH reports National Bureau of Standards research and development in physics, mathematics, chemistry, and engineering. Comprehensive scientific papers give complete details of the work, including laboratory data, experimental procedures, and theoretical and mathematical analyses. Illustrated with photographs, drawings, and charts.

Published in three sections, available separately:

● Physics and Chemistry

Papers of interest primarily to scientists working in these fields. This section covers a broad range of physical and chemical research, with major emphasis on standards of physical measurement, fundamental constants, and properties of matter. Issued six times a year. Annual subscription: Domestic, \$9.50; foreign, \$11.75*.

● Mathematical Sciences

Studies and compilations designed mainly for the mathematician and theoretical physicist. Topics in mathematical statistics, theory of experiment design, numerical analysis, theoretical physics and chemistry, logical design and programming of computers and computer systems. Short numerical tables. Issued quarterly. Annual subscription: Domestic, \$5.00; foreign, \$6.25*.

● Engineering and Instrumentation

Reporting results of interest chiefly to the engineer and the applied scientist. This section includes many of the new developments in instrumentation resulting from the Bureau's work in physical measurement, data processing, and development of test methods. It will also cover some of the work in acoustics, applied mechanics, building research, and cryogenic engineering. Issued quarterly. Annual subscription: Domestic, \$5.00; foreign, \$6.25*.

TECHNICAL NEWS BULLETIN

The best single source of information concerning the Bureau's research, developmental, cooperative and publication activities, this monthly publication is designed for the industry-oriented individual whose daily work involves intimate contact with science and technology—for *engineers, chemists, physicists, research managers, product-development managers, and company executives*. Annual subscription: Domestic, \$3.00; foreign, \$4.00*.

* Difference in price is due to extra cost of foreign mailing.

Order NBS publications from:

Superintendent of Documents
Government Printing Office
Washington, D.C. 20402

NONPERIODICALS

Applied Mathematics Series. Mathematical tables, manuals, and studies.

Building Science Series. Research results, test methods, and performance criteria of building materials, components, systems, and structures.

Handbooks. Recommended codes of engineering and industrial practice (including safety codes) developed in cooperation with interested industries, professional organizations, and regulatory bodies.

Special Publications. Proceedings of NBS conferences, bibliographies, annual reports, wall charts, pamphlets, etc.

Monographs. Major contributions to the technical literature on various subjects related to the Bureau's scientific and technical activities.

National Standard Reference Data Series. NSRDS provides quantitative data on the physical and chemical properties of materials, compiled from the world's literature and critically evaluated.

Product Standards. Provide requirements for sizes, types, quality and methods for testing various industrial products. These standards are developed cooperatively with interested Government and industry groups and provide the basis for common understanding of product characteristics for both buyers and sellers. Their use is voluntary.

Technical Notes. This series consists of communications and reports (covering both other agency and NBS-sponsored work) of limited or transitory interest.

Federal Information Processing Standards Publications. This series is the official publication within the Federal Government for information on standards adopted and promulgated under the Public Law 89-306, and Bureau of the Budget Circular A-86 entitled, Standardization of Data Elements and Codes in Data Systems.

CLEARINGHOUSE

The Clearinghouse for Federal Scientific and Technical Information, operated by NBS, supplies unclassified information related to Government-generated science and technology in defense, space, atomic energy, and other national programs. For further information on Clearinghouse services, write:

Clearinghouse
U.S. Department of Commerce
Springfield, Virginia 22151

U.S. DEPARTMENT OF COMMERCE
WASHINGTON, D.C. 20230

OFFICIAL BUSINESS



POSTAGE AND FEES PAID
U.S. DEPARTMENT OF COMMERCE
